

**Padilla, Felix**

**From:** Padilla, Felix  
**Sent:** Wednesday, May 20, 2026 9:54 AM  
**To:** Michael Hernandez  
**Subject:** RE: RedSpeed SDS Supports Vendor  
**Attachments:** T-10.pdf

Good morning Michael,

The Speed Detection System with the solar panels, depicted below, will be added to our approved list of devices with an effective date of 5/20/2026. I will include the attached plan drawing to our website.

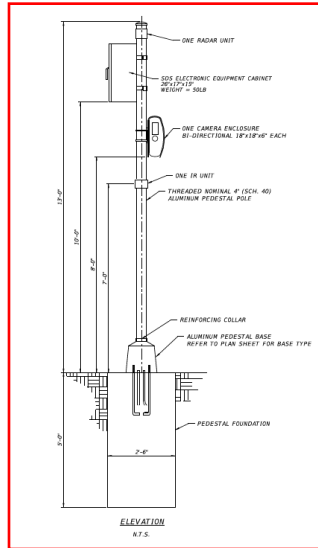
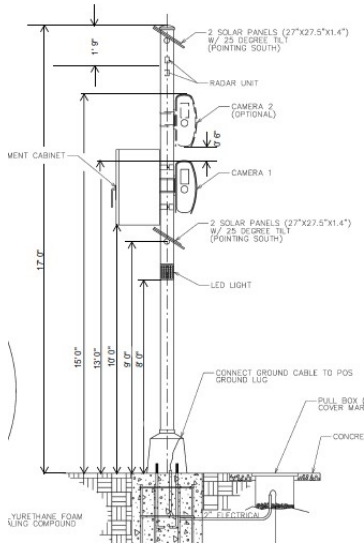

Amended to include the option without solar panels - FP 5/21/2026.

Please let me know if you have any questions or concerns.

Thank you,

Félix Padilla, P.E.  
State Traffic Services Program Engineer  
[FDOT-StateTrafficServicesSection@dot.state.fl.us](mailto:FDOT-StateTrafficServicesSection@dot.state.fl.us)  
(850) 410-5646

**From:** Michael Hernandez <mhernandez@caltrangroup.com>  
**Sent:** Thursday, May 14, 2026 11:21 AM  
**To:** Padilla, Felix <Felix.Padilla@dot.state.fl.us>  
**Subject:** Re: RedSpeed SDS Supports Vendor

Good morning Felix,

Please find attached as requested. Let me know if this will suffice to get approval. Thank you for your help!

Best regards,

Michael Hernandez  
Project Team Leader



790 NW 107 Avenue - Suite 200 - Miami, FL 33172



O (786) 456-7700

C (786) 543-2734

Miami - Tampa - Broward - Tallahassee

www.caltranguard.com  

---

**From:** Padilla, Felix <[Felix.Padilla@dot.state.fl.us](mailto:Felix.Padilla@dot.state.fl.us)>  
**Sent:** Thursday, May 14, 2026 9:31 AM  
**To:** Michael Hernandez <[mhernandez@caltranguard.com](mailto:mhernandez@caltranguard.com)>  
**Subject:** RE: RedSpeed SDS Supports Vendor

Good morning Michael,

Thank you for the updates. Can you add dimensions to each of the appurtenances in the pole?  
Apologies for not communicating that before. But that way our permit engineers can confirm that the same configuration that is approved is what is being proposed when they review future permits.

Félix Padilla, P.E.  
State Traffic Services Program Engineer  
[FDOT-StateTrafficServicesSection@dot.state.fl.us](mailto:FDOT-StateTrafficServicesSection@dot.state.fl.us)  
(850) 410-5646

---

**From:** Michael Hernandez <[mhernandez@caltranguard.com](mailto:mhernandez@caltranguard.com)>  
**Sent:** Tuesday, May 12, 2026 10:49 AM  
**To:** Padilla, Felix <[Felix.Padilla@dot.state.fl.us](mailto:Felix.Padilla@dot.state.fl.us)>  
**Subject:** RE: RedSpeed SDS Supports Vendor  
**Importance:** High

Good morning Felix,

Please find attached revised Structural Analysis with the correct details. And for Sheet 10 of the approved plans, we are not going to be using that detail. I have attached the detail we are using. Let me know if you need anything else on our side to get the approval and thank you for your help!

Best regards,

Michael Hernandez  
Project Team Leader



790 NW 107 Avenue - Suite 200 - Miami, FL 33172



O (786) 456-7700

C (786) 543-2734

Miami - Tampa - Broward - Tallahassee

www.caltranguard.com  

---

**From:** Padilla, Felix <[Felix.Padilla@dot.state.fl.us](mailto:Felix.Padilla@dot.state.fl.us)>  
**Sent:** Monday, May 11, 2026 11:29 AM  
**To:** Michael Hernandez <[mhernandez@caltranguard.com](mailto:mhernandez@caltranguard.com)>  
**Subject:** RE: RedSpeed SDS Supports Vendor

Good morning Michael,

Thank you for the reminder. Here are some comments on the documents you shared with me:

- For “APPROVED-HC-ROW-26-0000232.pdf” – on Sheet T-10, please update of confirm that the details shown here will not be the ones used, specifically the location of the cabinet being below the LED light, which does not match what was crash tested.
- For “MDC\_Single\_Column\_Gorund\_Sign\_Desgin\_Report\_SS”, please update the Pole Structural Foundation Detail to match the details on the crash test, specifically related to the location of all the appurtenances on the pole. This is page 92 of 102 on the document and is part of the drawings that we will use to show the approved system.

If you can get those details taken care of and send me the updates, I can approve the system and update the documents on our SDS website.

Thank you,

Félix Padilla, P.E.  
State Traffic Services Program Engineer  
[FDOT-StateTrafficServicesSection@dot.state.fl.us](mailto:FDOT-StateTrafficServicesSection@dot.state.fl.us)  
(850) 410-5646

---

**From:** Michael Hernandez <[mhernandez@caltrangroup.com](mailto:mhernandez@caltrangroup.com)>  
**Sent:** Monday, May 11, 2026 10:34 AM  
**To:** Padilla, Felix <[Felix.Padilla@dot.state.fl.us](mailto:Felix.Padilla@dot.state.fl.us)>  
**Subject:** RE: RedSpeed SDS Supports Vendor

Good morning Felix,

Just following up to see if you had a chance to look at the documents. Thanks!

Best regards,

**Michael Hernandez**  
Project Team Leader



790 NW 107 Avenue - Suite 200 - Miami, FL 33172



☎ (786) 456-7700  
☎ (786) 543-2734

Miami - Tampa - Broward - Tallahassee  
[www.caltrangroup.com](http://www.caltrangroup.com)  

---

**From:** Michael Hernandez <[mhernandez@caltrangroup.com](mailto:mhernandez@caltrangroup.com)>  
**Sent:** Wednesday, May 6, 2026 10:22 AM  
**To:** Padilla, Felix <[Felix.Padilla@dot.state.fl.us](mailto:Felix.Padilla@dot.state.fl.us)>  
**Cc:** Arnold, Scott <[Scott.Arnold@dot.state.fl.us](mailto:Scott.Arnold@dot.state.fl.us)>  
**Subject:** Re: RedSpeed SDS Supports Vendor  
**Importance:** High

Good morning Mr. Padilla,

Just following up on the request below. Please let me know if there is anything else you need from us to get this in the approved vendor list.

Best regards,

**Michael Hernandez**  
Project Team Leader



790 NW 107 Avenue - Suite 200 - Miami, FL 33172



O (786) 456-7700

C (786) 543-2734

Miami - Tampa - Broward - Tallahassee

[www.caltranguard.com](http://www.caltranguard.com)  

---

**From:** Michael Hernandez

**Sent:** Thursday, April 23, 2026 8:31 AM

**To:** 'Padilla, Felix' <[Felix.Padilla@dot.state.fl.us](mailto:Felix.Padilla@dot.state.fl.us)>; 'Arnold, Scott' <[Scott.Arnold@dot.state.fl.us](mailto:Scott.Arnold@dot.state.fl.us)>

**Cc:** 'Julio Silva' <[julio.silva@redspeed.com](mailto:julio.silva@redspeed.com)>

**Subject:** RE: RedSpeed SDS Supports Vendor

**Importance:** High

Good morning Mr. Padilla,

It seems the email I sent yesterday didn't go through. Please use the link below to download the documents requested and let me know if there is anything else we need to do on our part to get in the approved vendor list.

[SDS Docs](#)

Best regards,

**Michael Hernandez**  
Project Team Leader



790 NW 107 Avenue - Suite 200 - Miami, FL 33172



O (786) 456-7700

C (786) 543-2734

Miami - Tampa - Broward - Tallahassee

[www.caltranguard.com](http://www.caltranguard.com)  

**From:** Michael Hernandez  
**Sent:** Wednesday, April 22, 2026 6:25 PM  
**To:** Padilla, Felix <[Felix.Padilla@dot.state.fl.us](mailto:Felix.Padilla@dot.state.fl.us)>; 'Arnold, Scott' <[Scott.Arnold@dot.state.fl.us](mailto:Scott.Arnold@dot.state.fl.us)>  
**Cc:** Julio Silva <[julio.silva@redspeed.com](mailto:julio.silva@redspeed.com)>  
**Subject:** RE: RedSpeed SDS Supports Vendor

Thank you, Mr. Arnold.

Mr. Padilla,

Please find attached requested files. Please let me know if there anything else needed.

Best regards,

**Michael Hernandez**  
Project Team Leader



790 NW 107 Avenue - Suite 200 - Miami, FL 33172



☎ (786) 456-7700  
📞 (786) 543-2734

Miami - Tampa - Broward - Tallahassee  
[www.caltranguard.com](http://www.caltranguard.com)  

---

**From:** Arnold, Scott <[Scott.Arnold@dot.state.fl.us](mailto:Scott.Arnold@dot.state.fl.us)>  
**Sent:** Wednesday, April 22, 2026 5:13 PM  
**To:** Michael Hernandez <[mhernandez@caltranguard.com](mailto:mhernandez@caltranguard.com)>  
**Cc:** Julio Silva <[julio.silva@redspeed.com](mailto:julio.silva@redspeed.com)>; Padilla, Felix <[Felix.Padilla@dot.state.fl.us](mailto:Felix.Padilla@dot.state.fl.us)>  
**Subject:** RE: RedSpeed SDS Supports Vendor

Michael,

I know you show an email that was sent to me on April 13, 2026, but I don't seem to have received it or any attachments. I have moved to another position and Dibakar no longer works for the Department, so please send your crash test report, plans and structural calculations to Felix Padilla. He will review your submittal.

Scott C. Arnold, P.E.

Director of Maintenance

Florida Department of Transportation

cell (850) 755-7592

---

**From:** Michael Hernandez <[mhernandez@caltranguard.com](mailto:mhernandez@caltranguard.com)>  
**Sent:** Wednesday, April 22, 2026 1:31 PM  
**To:** Arnold, Scott <[Scott.Arnold@dot.state.fl.us](mailto:Scott.Arnold@dot.state.fl.us)>  
**Cc:** Saha, Dibakar <[Dibakar.Saha@dot.state.fl.us](mailto:Dibakar.Saha@dot.state.fl.us)>; Julio Silva <[julio.silva@redspeed.com](mailto:julio.silva@redspeed.com)>  
**Subject:** Re: RedSpeed SDS Supports Vendor

Good afternoon Mr. Arnold,

Just following on the request below.

Best regards,

**Michael Hernandez**  
Project Team Leader



790 NW 107 Avenue - Suite 200 - Miami, FL 33172



☎ (786) 456-7700  
📠 (786) 543-2734

Miami - Tampa - Broward - Tallahassee  
[www.caltranguard.com](http://www.caltranguard.com)  

---

**From:** Michael Hernandez  
**Sent:** Monday, April 13, 2026 1:51 PM  
**To:** Arnold, Scott <[Scott.Arnold@dot.state.fl.us](mailto:Scott.Arnold@dot.state.fl.us)>  
**Cc:** Saha, Dibakar <[Dibakar.Saha@dot.state.fl.us](mailto:Dibakar.Saha@dot.state.fl.us)>  
**Subject:** RE: RedSpeed SDS Supports Vendor

Good afternoon Mr. Arnold,

We have finally performed the Impact Test requested for RedSpeed SDS (see attached report). Also, I'm attaching structural calculations and a set of plans for your use. Please let me know if there is anything else we are missing to get RedSpeed approved as a vendor.

Best regards,

**Michael Hernandez**  
Project Team Leader

790 NW 107 Avenue - Suite 200 - Miami, FL 33172



(786) 456-7700  
(786) 543-2734

Miami - Tampa - Broward - Tallahassee  
www.caltranguard.com  



CALTRAN  
ENGINEERING GROUP  
*"Engineering for the Capital"*

---

**From:** Arnold, Scott <[Scott.Arnold@dot.state.fl.us](mailto:Scott.Arnold@dot.state.fl.us)>  
**Sent:** Monday, August 18, 2025 4:48 PM  
**To:** Michael Hernandez <[mhernandez@caltranguard.com](mailto:mhernandez@caltranguard.com)>  
**Cc:** Saha, Dibakar <[Dibakar.Saha@dot.state.fl.us](mailto:Dibakar.Saha@dot.state.fl.us)>  
**Subject:** RE: RedSpeed SDS Supports Vendor

Michael,

Please address the following comments:

1. Provide an impact testing report as required in Chapter 12 of the AASHTO LRFD Specifications for Structural Supports for Highway Signs, Luminaires, and Traffic Signals (LTS-1).
2. The concrete compressive strength used for the drilled shaft foundation design is 3.0 ksi. The concrete strength used for the spread footing design is 5.0 ksi. Note 3 on the plan sheet calls for Class I concrete, which is 3.0 ksi. Need to reconcile.
3. Note 7 on the plan sheet states, "Attachment of the devices and enclosure to the aluminum pole is the responsibility of the contractor." Attachment details must be shown in the plans that are submitted for approval. The same attachment details must be used in crash testing.

Please contact me if you have any questions.

Scott C. Arnold, P.E.

State Maintenance Engineer

cell (850) 755-7592



---

**From:** Michael Hernandez <[mhernandez@caltrangroup.com](mailto:mhernandez@caltrangroup.com)>  
**Sent:** Wednesday, August 13, 2025 9:22 AM  
**To:** Arnold, Scott <[Scott.Arnold@dot.state.fl.us](mailto:Scott.Arnold@dot.state.fl.us)>  
**Cc:** Saha, Dibakar <[Dibakar.Saha@dot.state.fl.us](mailto:Dibakar.Saha@dot.state.fl.us)>  
**Subject:** Re: RedSpeed SDS Supports Vendor  
**Importance:** High

Good morning,

Following up on the request below. Could you let me know if there is anything else we need in order to get the approval letter? Thank you in advance for your help.

Best regards,

**Michael Hernandez**  
Project Team Leader



790 NW 107 Avenue - Suite 200 - Miami, FL 33172



☎ (786) 456-7700  
☎ (786) 543-2734

Miami - Tampa - Broward - Tallahassee  
[www.caltrangroup.com](http://www.caltrangroup.com)  

---

**From:** Michael Hernandez  
**Sent:** Thursday, August 7, 2025 9:54 AM  
**To:** Arnold, Scott <[Scott.Arnold@dot.state.fl.us](mailto:Scott.Arnold@dot.state.fl.us)>  
**Cc:** Robert Liberman <[Robert.Liberman@redspeed.com](mailto:Robert.Liberman@redspeed.com)>; Saha, Dibakar <[Dibakar.Saha@dot.state.fl.us](mailto:Dibakar.Saha@dot.state.fl.us)>  
**Subject:** RE: RedSpeed SDS Supports Vendor

Good morning Mr. Arnold,

We will be using, moving forward, the attached standards for all RedSpeed SDS support (both wired and solar). Please let me know if this will suffice to address the comments below.

Best regards,

**Michael Hernandez**  
Project Team Leader



790 NW 107 Avenue - Suite 200 - Miami, FL 33172



☎ (786) 456-7700  
☎ (786) 543-2734

Miami - Tampa - Broward - Tallahassee  
www.caltranguard.com  

---

**From:** Arnold, Scott <[Scott.Arnold@dot.state.fl.us](mailto:Scott.Arnold@dot.state.fl.us)>  
**Sent:** Wednesday, August 6, 2025 3:32 PM  
**To:** Michael Hernandez <[mhernandez@caltranguard.com](mailto:mhernandez@caltranguard.com)>  
**Cc:** Robert Liberman <[Robert.Liberman@redspeed.com](mailto:Robert.Liberman@redspeed.com)>; Saha, Dibakar <[Dibakar.Saha@dot.state.fl.us](mailto:Dibakar.Saha@dot.state.fl.us)>  
**Subject:** RedSpeed SDS Supports Vendor

Michael,

Following are my comments on the SDS supports shown in the attached files. These files are pages extracted from the approved permits you emailed to me.

### **2025-K-491-00062**

1. Note #8 on sheet T-9 states, "Shop drawings are required." This is not acceptable, all details needed to construct and install this SDS support must be included in these plans.
2. Height of the electronic equipment cabinet above the top of foundation must be dimensioned.
3. Component to pole attachment details must be included in the plans.
4. Provide an impact testing report as required in Chapter 12 of the AASHTO LRFD Specifications for Structural Supports for Highway Signs, Luminaires, and Traffic Signals (LTS-1).

### **2024-K-691-00081**

1. The details shown on Sheet T-6 are insufficient to construct and install this SDS support.
2. Provide a structural analysis in accordance with the AASHTO LTS-1.

3. Provide an impact testing report in accordance with the AASHTO LTS-1.

Scott C. Arnold, P.E.

State Maintenance Engineer

cell (850) 755-7592



---

**From:** Michael Hernandez <[mhernandez@caltrangroup.com](mailto:mhernandez@caltrangroup.com)>  
**Sent:** Tuesday, August 5, 2025 3:27 PM  
**To:** Arnold, Scott <[Scott.Arnold@dot.state.fl.us](mailto:Scott.Arnold@dot.state.fl.us)>  
**Cc:** Robert Liberman <[Robert.Liberman@redspeed.com](mailto:Robert.Liberman@redspeed.com)>  
**Subject:** RE: Approved SDS Supports Vendor  
**Importance:** High

**EXTERNAL SENDER:** Use caution with links and attachments.

Good afternoon Mr. Arnold,

As per your conversation with Mr. Liberman, please find attached approved plans by FDOT in which cameras are wire powered. Let me know if you have any questions or need additional information.

Best regards,

**Michael Hernandez**  
Project Team Leader



790 NW 107 Avenue - Suite 200 - Miami, FL 33172



☎ (786) 456-7700

☎ (786) 543-2734

Miami - Tampa - Broward - Tallahassee

[www.caltrangroup.com](http://www.caltrangroup.com)  

---

**From:** Robert Liberman <[Robert.Liberman@redspeed.com](mailto:Robert.Liberman@redspeed.com)>  
**Sent:** Tuesday, August 5, 2025 1:39 PM  
**To:** [scott.arnold@dot.state.fl.us](mailto:scott.arnold@dot.state.fl.us)  
**Cc:** Michael Hernandez <[mhernandez@caltransgroup.com](mailto:mhernandez@caltransgroup.com)>  
**Subject:** RE: Approved SDS Supports Vendor

Mr. Arnold,

It was a pleasure speaking with you! Please let us know if you have comments or changes for our plan. We hope to get on the approved list as soon as possible.

Robert Liberman

CEO RedSpeed

630-329-9856

---

**From:** Michael Hernandez <[mhernandez@caltransgroup.com](mailto:mhernandez@caltransgroup.com)>  
**Sent:** Tuesday, August 5, 2025 12:40 PM  
**To:** [scott.arnold@dot.state.fl.us](mailto:scott.arnold@dot.state.fl.us)  
**Cc:** Robert Liberman <[Robert.Liberman@redspeed.com](mailto:Robert.Liberman@redspeed.com)>  
**Subject:** Re: Approved SDS Supports Vendor

**Caution:** EXTERNAL EMAIL. Do not click links or open attachments unless you recognize the sender and know the content is safe.

Good afternoon Mr. Arnold,

Just following up in my email below. We are trying to get RedSpeed in the SDS support list. I'm attaching approved plans by FDOT D4 and support calculations for your use. We have already submitted plans for D6 and D5 as well with our calculations and they have been approved. Please let us know if there is anything else needed to be added to this list.

Best regards,

**Michael J.Hernandez**

**Project Team Leader**

**CALTRAN Engineering Group, Inc.**

790 NW 107 Avenue, Suite 200

Miami, FL 33172

**O: 786 456 7700**

**C: 786 543 2734**

Sent from my iPhone

On Jul 30, 2025, at 1:36 PM, Michael Hernandez <[mhernandez@caltrangroup.com](mailto:mhernandez@caltrangroup.com)> wrote:

Good afternoon Mr. Arnold,

My client (RedSpeed, Florida) is looking to get in to the approved SDS support vendor list. We have structural details and calculation of the poles used in these types of cameras. Where do we need to apply or which information is needed to be added to this list? Thank you in advance for your help regarding this matter.

Best regards,