



CONNECTED VEHICLES

Lessons Learned & Best Practices

2026 Edition



DISCLAIMER:

This document is intended to be an informational resource and does not relieve Engineers of Record of the responsibility to design a fully functional and implementable system. The following guidance is based upon previous experience in the project management, planning, design, deployment, and operation of connected vehicle systems within Florida and has been made available to assist in project efforts; but does not supersede engineering judgement. Designers and Construction Contractors must coordinate with District and local maintaining personnel to fully understand current conditions, project requirements, and limitations of the available system(s)—including networking configuration constraints, integration with central systems (e.g., SunGuide, SCMS, DEPOT), known operational issues, maintenance considerations, pace of technology, and more. Furthermore, this document is not intended to be all inclusive. The Engineer of Record shall be responsible for all aspects of design and Construction Contractors shall be responsible for all aspects of construction—including coordination efforts, procedural steps, and processes of the Department that are not explicitly referenced or defined in this document—based on individual experience and project-specific field conditions. Please note that some links are internal and only accessible with an FDOT account and can be made available upon request to the District TSM&O or Central Office CAV team. This redacted version redacts all the default IPs and credentials to field devices and systems.

Table of Contents

- Section 1 : Introduction 1
 - 1.1 Background 1
 - 1.1.1 History 1
 - 1.2 Purpose 1
 - 1.2.1 Organization of this Document 1
 - 1.2.2 Assumptions Made 2
 - 1.2.3 Users and Intended Audience 2
 - 1.3 Revisions and References 2
 - 1.3.1 Revisions 2
 - 1.3.2 References 2
 - 1.4 Definitions of Terms and Acronyms 3
- Section 2 : Planning and Project Development 7
 - 2.1 Introduction 7
 - 2.2 Design Project Scoping Statewide Planning Process Overview 7
 - 2.3 District and Regional Planning Process Overview 8
 - 2.3.1 Long Range Transportation Plans 8
 - 2.3.2 Regional TSM&O Plans 8
 - 2.4 TSM&O Project Planning Overview 9
 - 2.4.1 10-Year ITS Cost Feasible Plan 9
 - 2.4.2 Regional ITS Architectures 10
 - 2.4.3 FDOT Five Year Work Program 10
 - 2.5 Preliminary Project Development 11
 - 2.5.1 PD&E Process and Scoping 11
 - 2.5.2 Tailored Systems Engineering Analysis 13
 - 2.6 Project Evaluation/Studies/Research 15
- Section 3 : Design Considerations 16
 - 3.1 Preliminary Engineering Considerations 16
 - 3.1.1 Systems Engineering Updates 16
 - 3.1.2 Field Reviews 25
 - 3.1.3 Stakeholder Coordination 39
 - 3.1.4 Technology 40
 - 3.2 Final Engineering and Design Considerations 41

- 3.2.1 Design Considerations 41
- 3.2.2 Plans Development 53
- 3.2.3 Specifications 55
- Section 4 : Material Procurement Considerations..... 61
 - 4.1 Roadside Units and Equipment 61
 - 4.2 On-Board Units 62
 - 4.3 Other Devices to Consider in Materials Procurement for a CV Project 64
 - 4.4 Other Devices Considered incidental in Materials Procurement for a CV project..... 65
- Section 5 : Construction Considerations..... 67
 - 5.1 Contract Types..... 67
 - 5.1.1 Design-Bid-Build 67
 - 5.1.2 Design-Build 68
 - 5.1.3 Systems Manager 69
 - 5.1.4 Other Project Coordination Considerations 70
 - 5.2 Configuration, Installation, and Integration..... 71
 - 5.2.1 Network Access and Security..... 71
 - 5.2.2 FCC Data Collection and Site Registration Process 72
 - 5.2.3 MAP Development Guidelines 73
 - 5.2.4 SCMS Requirements and Processes..... 74
 - 5.2.5 DEPOT Requirements and Processes 78
 - 5.2.6 RSU HMS Requirements and Processes..... 79
 - 5.2.7 Managing and Tracking Device Information 79
 - 5.3 Project Requirements, Testing, and Acceptance..... 80
 - 5.3.1 Field Testing 80
 - 5.3.2 System Testing 81
 - 5.4 As-built Information and Documentation 81
 - 5.4.1 ITSFM Asset Form 81
- Section 6 : Operations and Maintenance Considerations 83
 - 6.1 Operational Software 83
 - 6.1.1 FDOT Statewide Software (SunGuide, SCMS, DEPOT) 83
 - 6.1.2 Vendor-specific Software Systems..... 87
 - 6.1.3 General User Account recommendations..... 88
 - 6.1.4 Licensing..... 88

6.2 Preventive Maintenance and Troubleshooting..... 88

 6.2.1 Centralized Operational Monitoring and Checks..... 88

 6.2.2 Useful Tools..... 91

Appendix 1: Networking Lessons Learned and Best Practices 96

 A.1.1 Configuration, Installation, and Integration..... 96

Appendix 2: Forms, Checklists and Questionnaires..... 98

 A2. Ch3.1 - Concept of Operations..... 98

 A2. Ch3.2 - Systems Testing and Validation Plan 99

 A2. Ch3.3 - Requirements Traceability and Verification Matrix..... 101

 A2. Ch3.4 - Communications Field Review Questionnaire 101

 A2. Ch3.5 - Power Field Review Questionnaire 101

 A2. Ch3.5 – Structures Field Review Questionnaire..... 102

 A2. Ch3.6 Cabinets, Enclosures, and Field Devices Questionnaire 103

 A2. Ch3.7 Associated Infrastructure Questionnaire..... 107

 A2. Ch3.8 Traffic Control Device Permits 108

 A2. Ch5.1 Data Collection for FCC Site Registration..... 109

 A2. Ch5.2 ITSFM Asset Form 109

List of Figures

Figure 2-1: Visualization of Statewide Planning Process 7

Figure 2-2: Visualization of Regional Planning Process..... 8

Figure 2-3: Visualization of TSM&O and CAV Project Planning Process 9

Figure 2-4: Visualization of TSM&O and CAV in the PD&E Process..... 11

Figure 2-5: Visualization of Systems Engineering Analysis 14

Figure 3-6: Example Service Package containing Connected Vehicle technology (I-4 FRAME, District One)..... 18

Figure 3-7: Example application function diagrams for Emergency Vehicle Preemption (left) and Railroad Crossing Violation Warning (right)..... 21

Figure 3-8: Illustration depicting the relationship between message and applications..... 22

Figure 3-9: Relationship between the ConOps and the System Testing and Validation Plan 25

Figure 3-10: Example RTVM using the adopted Department template. 25

Figure 3-11: Examples of different networking communication equipment 27

Figure 3-12: Example power infrastructure components including in-cabinet equipment (left) and infrastructure (right) 29

Figure 3-14: Examples of various roadside unit mounting scenarios 32

Figure 3-15: Examples of signal controller cabinet assembly interiors	36
Figure 3-16: Examples of Intelligent Transportation Systems cabinet assembly interiors.....	38
Figure 3-18: Typical mast arm installation showing recommended horizontal and vertical clearance of antennas to avoid occlusion and signal interference	42
Figure 3-19: Typical strain pole installation with recommended horizontal clearance of antennas	43
Figure 3-20: Typical roadside unit deployment on structure location on outside shoulder of limited- access corridor	45
Figure 3-21: Typical roadside unit deployment of structure location installed in the median of a limited-access corridor.....	46
Figure 3-22: Example Connected Vehicle architecture for typical ITS deployment	50
Figure 3-23: Developmental Specification for Connected Vehicle Roadside Equipment, Sections and 681 and 695.....	56
Figure 3-24: Connected Vehicle testing includes multiple steps to complete the process.....	57
Figure 3-25: Excerpts from Developmental Specification and Standard Specification identifying subdivided portions of CV device manufacturer and field installation testing as well as ITS System Acceptance Test.....	59
Figure 5-1: Visualization of Project Delivery for a Design-Bid-Build	68
Figure 5-2: Visualization of Project Delivery for a Design-Build	69
Figure 5-3: Site Registration Data Collection Spreadsheet	72
Figure 5-4: License information for WQBS407 on FCC ULS	73
Figure 5-5: SCMS Enrollment Process	76
Figure 5-6: SCMS Device Type and Enrollment Profile Selection.....	77
Figure 5-7: List of Certificate types in RSU Enrollment Profiles.....	77
Figure 6-1: Home Page of FDOT SCMS.....	84
Figure 6-4: Home Page of FDOT RSU Health Monitoring System	85
Figure 6-7: DEPOT (formerly V2X DEP) High-level System Architecture	86
Figure 6-12: ISS Portal showing an OBU device status and tags.....	89
Figure 6-13: Portable OBU with Wi-Fi adapter and Realtime Diagnostic Application on Android Tablet	90
Figure 6-14: Overview Data using Realtime Diagnostic Application on Android Tablet.....	91
Figure 6-16: Example of “Unsafe Site” Warning during RSU Webmin Page Access	92
Figure 6-17: Example of Common Terminal Program that can be used for RSU CLI access.....	93
Figure 6-18: Example of Terminal Session with RSU	93
Figure 6-19: Example of Common File Transfer Program.....	94
Figure 6-20: WinSCP session showing RSU aerolink/certificates folder related to SCMS	94

List of Tables

Table 2-1: Example of CAV Related Project in the Current 5-Year Work Plan.....	10
Table 2-2: Example of CAV Related Project in the Current 5-Year Work Plan.....	11
Table 3-3: Field Review Questionnaire - Communications.....	26
Table 3-4: Field Review Questionnaire – Power	28
Table 3-5: Field Review Questionnaire – Structures.....	30
Table 3-6: Field Review Questionnaire – Signalized Intersection Equipment	32
Table 3-7: Field Review Questionnaire – Intelligent Transportation System Cabinet Assembly.....	36
Table 3-8: Field Review Questionnaire – Associated Infrastructure.....	38

Section 1: Introduction

1.1 Background

The Florida Department of Transportation's (FDOT) mission is to provide a safe transportation system that ensures the mobility of people and goods, enhances economic prosperity, and preserves the quality of our environment and communities. FDOT's Connected and Autonomous Vehicles (CAV) program and Connected Vehicles (CV) technologies serve as one of tools to achieve this goal.

1.1.1 History

After the success of the real world [Connected Vehicle Safety Pilot Model Deployment](#)ⁱ in 2012 to 2013, in August 2014, National Highway Safety Traffic Administration (NHTSA) released an Advance Notice of Proposed Rulemaking (ANPRM) and a supporting comprehensive research report on [Vehicle to vehicle \(V2V\) communications technology](#).ⁱⁱ Research across University Transportation Centers (UTCs), pre-deployment, collaboration and subsequent grant funding became available. By 2015, Florida became one of four initial states (along with Michigan, Wyoming, and New York) to start deployment of Connected Vehicle Technology via the US Department of Transportation's (USDOT) Connected Vehicle Pilot Program through the Intelligent Transportation Systems-Joint Program Office (ITS-JPO). Florida's first permanent installation of CV technologies was the [Tampa-Hillsborough Expressway Authority \(THEA\) pilot](#)ⁱⁱⁱ with on-board units (OBU) for cars, buses, trolleys, and roadside units (RSU) at 40+ locations. During this same time (2014-2016), FDOT Central Office staff, FDOT District Staff, partner universities, expressway authorities, local agencies, and private industry started concepts, pilot deployments, and collaborative discussions to accelerate various Connected Vehicle Pilot project deployments. By 2018 several projects across Florida in the cities of Orlando, Gainesville, Tallahassee, and Tampa were deployed. Thereafter, the [2019 FDOT CAV Business Plan](#)^{iv} was released to serve as a high-level guidance document, and to synchronize CAV deployment efforts across Florida.

1.2 Purpose

The purpose of this document is to share lessons learned and provide general guidance related to the planning, design, procurement, construction, operation, and maintenance of CV equipment. There is a wealth of existing information and documentation on many different aspects of FDOT's CAV program. When possible, this document directs the reader to online resources that can provide additional and comprehensive information on a given topic.

The intended audience for this document includes local and state agency project managers, Engineers of Record (EOR), system designers, equipment vendors, construction contractors, system integrators, and other stakeholders.

1.2.1 Organization of this Document

The organization of this document generally follows the Project Development Process, (Planning/PD&E, Design, Procurement, Construction) and supplements it with additional information on Operations and Maintenance, as well as appendices related to networking. It provides guidance and information that should be considered, and applied as appropriate, during various project stages.

1.2.2 Assumptions Made

This document assumes that the audience has a general familiarity with typical project development processes used by FDOT and its partners as well as basic understanding of traditional transportation systems and technologies.

1.2.3 Users and Intended Audience

The document is intended for planners, engineers, IT professionals, and field technical practitioners within the CV ecosystem. It is particularly geared towards the digital and physical infrastructure side of CV. Although the domain of CAV and Vehicle-to-Everything (V2X) is broad, this document focuses primarily on technologies that help Infrastructure Owner Operators (IOOs) improve safety and mobility through connectivity and communication, data sharing, and applications. The primary devices that accomplished this connectivity and communication between vehicle and infrastructure are the RSU and the OBU, CV applications that leverage V2X hardware and connectivity, and various centralized systems that collect, use, and share CV data for various purposes (e.g., SunGuide, DEPOT).

1.3 Revisions and References

1.3.1 Revisions

Any comments or suggestions concerning this handbook may be made by e-mailing Christine.Shafik@dot.state.fl.us. FDOT will routinely make revisions to keep the CV Lessons Learned and Best Practices guide consistent with other FDOT documents and to reflect changes and trends, technologies, and additional lessons learned through continued implementation of CV infrastructure.

1.3.2 References

- *FDOT Traffic Engineering Manual (TEM)*, latest version
- *Florida Design Manual (FDM)*, latest version
- *FDOT Standard Plans for Road and Bridge Construction*, latest version
- *FDOT Standard Specifications for Road and Bridge Construction*, latest version
- *FDOT Basis of Estimates*, latest version
- *FDOT Approved Products List*, latest version
- *FHWA Manual on Uniform Traffic Control Devices (MUTCD) for Streets and Highways*
- *ITE ATC 5201 – Advanced Transportation Controller Standard*
- *NEMA Standards Publication TS 2-2021, Traffic Controller Assemblies with NTCIP Requirements*
- *CTI 4001,v01.01-Amendment 1 (or later), Roadside Unit (RSU) Standard*
- *CTI 4501,v01.01 (or later), Connected Intersections Implementation Guide*
- *NTCIP 1218*
- *SAE J2735, V2X Communications Message Set Dictionary*
- *SAE J2945/X Connected Vehicle Standards*
- *SAE J2540-2, ITIS Phrase Lists (International Traveler Information Systems)*
- *SAE J3268, Listing of Provider Service Identifiers and Associated Application Technical Reports*
- *SAE J3224, V2X Sensor-Sharing for Cooperative and Automated Driving*

1.4 Definitions of Terms and Acronyms

AES	Advanced Encryption Standard
AMP	Arterial Management Program
ANPRM/NPRM	Advance Notice of Proposed Rulemaking/Notice of Proposed Rulemaking
APL	Approved Product List
APN	Access Point Name (SIM card on an APN)
ASD	Aftermarket Safety Device
ATC	Advanced Transportation Controller
ATMS	Advanced Traffic Management Software
AVI	Automated Vehicle Identification
BIU	Bus Interface Unit
BSM	Basic Safety Message
CAMP	Crash Avoidance Metrics Partnerships
CAN	Control Area Network
CAV	Connected and Autonomous Vehicles
CEI	Construction, Engineering, Inspection
CFP	Cost Feasibility Plan
CFR	Code of Federal Regulations
CLI	Command Line Interface (as opposed to Webmin, or GUI administration)
CMCC	Connected Mobility Control Center (Kapsch Central System for RSUs and Connected Vehicle)
CMS	Certificate Management System <i>Note: CMS could also mean Credential Management System, or Claims Management System..</i>
CMS	Cooperative Management System (Yunex Central System for RSUs and Connected Vehicles)
CO	Central Office (FDOT Central Office in Tallahassee)
ConOps	Concept of Operations
CSR	Certificate Signing Request
C-V2X	Cellular Vehicle-to-Everything
CV	Connected Vehicle
CVRSE	Connected Vehicle Roadside Equipment
CVS	Connected Vehicle Subsystem
CVPFS	Connected Vehicle Pooled Fund Study
DEPOT	Data Exchange Platform for Operational Technology (formerly V2X DEP)
DevSpec	Developmental Specification
DGPS	Differential Global Positioning System
DITS	District ITS funds (see ITS)
DIVAS	Data Integration and Video Aggregation System
DMS	Dynamic Message Sign
DNS	Domain Name Server
DSRC	Dedicated Short-Range Communication
DTOE	District Traffic Operations Engineer
EA	Environmental Assessment
ECDSA	Elliptic Curve Digital Signature Algorithm
EE	End Entity
EIRP	Equivalent Isotropic Radiated Power

EIS	Environmental Impact Statement
EOR	Engineer of Record
EVP	Verify Emergency Vehicle Preemption
FAT	Field Acceptance Testing
FDOT	Florida Department of Transportation
FDM	Florida Design Manual
FCC	Federal Communications Commission
FION	Florida ITS Operations Network
FTP	Florida Transportation Plan
FPID	Financial Project Identification
GHz	Gigahertz
GUI	Graphical User Interface
HSM	Hardware Security Module
ICMP	Internet Control Message Protocol (protocol used by “ping” command)
IEEE	Institute of Electrical and Electronics Engineers
IOOS	Infrastructure Owner Operators
ISD	Intersection Situation Data (for MAP and SPaT)
ISS	Integrity Security Services, LLC (vendor for SCMS Portal)
ITIS	International Traveler Information Systems (e.g., ITIS codes)
ITS	Intelligent Transportation Systems
ITS-JPO	Intelligent Transportation Systems-Joint Program Office.
ITSFM	ITS Facility Management (System). FDOT ITS field equipment asset management tool
IVP	Integrated V2I Prototype
LAT/LON	Latitude/Longitude
LIDAR	Light Detection and Ranging
LOT	Letter of Transmittal
L RTP	Long Range Transportation Plans
MAC	Media Access Control (MAC Address in Layer 2)
MAP	SAE J2735 Message that contains road geometry information, lane information, and other data
MFES	Managed Field Ethernet Switch
MHz	Megahertz (1,000,000 hertz)
MMU	Malfunction Management Unit
MPO	Metropolitan Planning Organization
MOU	Memorandum of Understanding
MSP	Modified Special Provisions
MVDS	Microwave Vehicle Detection Systems
NDAA	National Defense Authorization Act
NHTSA	National Highway Safety Traffic Administration
NMS	Network Management System
NTCIP	National Transportation Communications for Intelligent Transportation Systems
O&M	Operations and Maintenance
OEM	Original Equipment Manufacturer (Refers to Vehicle Manufacturers)
OBD	On-Board-Diagnostics
OBU	On-Board Unit
OID	Object Identifier
PD&E	Project Development and Environment
PM	Project Management

POE	Power-Over Ethernet
PRTG	Paessler Router Traffic Grapher (A network monitoring software)
PSEMP	Project Systems Engineering Management Plan
PSID	Provider Service Identifiers
PSM	Personal Safety Message
PVD	PVD Probe Vehicle Data
RFC	Release for Construction
RFP	Request for Proposal
RITSA	Regional ITS Architectures (see ITS)
RPMU	Remote Power Management Unit
RSE	Roadside Equipment (Including RSU)
RSU	Roadside Unit
RSU-HMS	Roadside Unit Health Monitoring System
RTVM	Requirements Traceability and Verification Matrix
SAE	Society of Automotive Engineers
SAE J2735	SAE's V2X Communications Message Set Dictionary
SAT	System Acceptance Testing
SCMS	Security Credential Management System
SCP	Secure Copy Protocol (i.e. WinSCP)
SDSM	Sensor Data Sharing Message
SE	Systems Engineering
SFP	Small-Form Pluggable
SITSA	Statewide ITS Architecture (see ITS)
SIM	Subscriber Identity Module (Cell SIM cards)
SPD	Surge Protection Devices
SNMP	Simple Network Management Protocol
SNMPv3	Simple Network Management Protocol version 3 (current version used for RSU management)
SOP	Sequence of Operation (Traffic Signal Sequence of Operation)
SPAT/SPaT	Signal Phasing and Timing
SRM	Signal Request Message
SSAT	Sub-system Acceptance Testing
SSM	Signal Status Message
SSH	Secure Shell
STAMP	Statewide Arterial Management Program
TEO/TEOO	Traffic Engineering and Operations Office (typically refers to Central Office)
TERL	Traffic Engineering Research Laboratory
THEA	Tampa-Hillsborough Expressway Authority
TIM	Traffic Information Message
TPO	Transportation Planning Organization
TSM&O	Transportation Systems Management and Operations
TSMCA	Traffic Signal Maintenance and Compensation Agreements
TSP	Transit Signal Priority
UDP	User Datagram Protocol
ULS	Universal Licensing System (FCC Licensing)
USDOT	United States Department of Transportation
UTC	University Transportation Center
VM	Virtual Machine

V2V	Vehicle to Vehicle
V2X	Vehicle-to-Everything
V2X DEP	Vehicle-to-Everything Data Exchange Platform, see DEPOT
VRU	Vulnerable Road User
WAVE	Wireless Access in Vehicular Environments
Webmin	Web-based Administration (as opposed to CLI, or GUI administration)
WIM	Weight in Motion
WQBS407	FCC call sign associated with Florida’s 5.9GHz Public Safety license for CV operation

ⁱ History of Intelligent Transportation, 2023 Edition. “The 2010s” -

https://www.its.dot.gov/history/pdf/HistoryofITS_book.pdf

ⁱⁱ U.S. Department of Transportation Issues Advance Notice of Proposed Rulemaking to Begin Implementation of Vehicle-to-Vehicle Communications Technology - <https://www.transportation.gov/briefing-room/us-department-transportation-issues-advance-notice-proposed-rulemaking-begin>

ⁱⁱⁱ THEA Pilot - <https://theacvpilot.com/> or ITS-JPO version - https://www.its.dot.gov/pilots/pilots_thea.htm

^{iv} 2019 CAV Business Plan <https://fdotwww.blob.core.windows.net/sitefinity/docs/default-source/traffic/its/floridaconnects/fdot-cav-business-plan-2019.pdf>

Section 2: Planning and Project Development

2.1 Introduction

Transportation planning identifies and prioritizes transportation improvements that support statewide, regional, and local goals and objectives. Transportation improvements range from adding capacity (e.g., new roadways, new lanes, new transit, etc.) to improving the safety and mobility of existing transportation systems through enhanced operations and maintenance.

FDOT has adopted the Target Zero goal for transportation fatalities and serious injuries. Intelligent transportation systems (ITS) technologies along with transportation systems management and operations (TSM&O) programs improve transportation safety and mobility. Emerging transportation technologies, such as CAV technologies and applications, will enable FDOT and local transportation organizations to continue progress toward Target Zero.



Planning and project development activities should be led by FDOT and partner agency planning office personnel with input from key stakeholders as necessary (e.g., TSM&O, CAV, and STAMP champions). FDOT District TSM&O Program Engineers may request department coordination activities with District ITS Engineers and/or AMP (Arterial Management Program) engineers/managers, where applicable, based on project scope, complexity, and other factors. This chapter summarizes mainstreaming CAV technologies and applications into key FDOT planning and project development processes, including:

- Long Range Transportation Plans (LRTP)
- TSM&O Master Plans (also called Strategic Plans or Implementation Plans)
- Project Development and Environment (PD&E) Analysis

2.2 Design Project Scoping Statewide Planning Process Overview

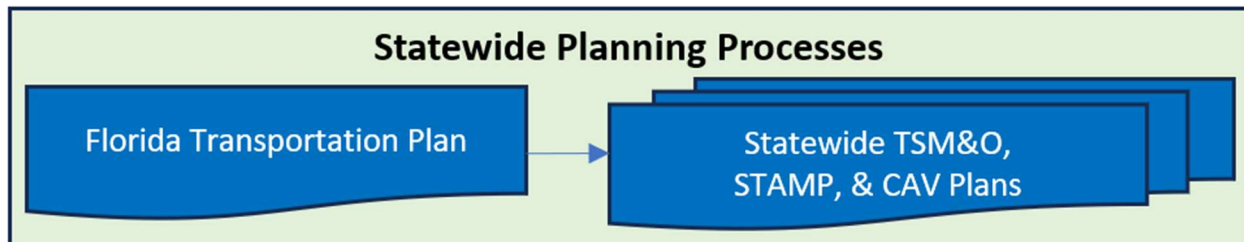

Figure 2-1: Visualization of Statewide Planning Process

The FDOT Central Office, in collaboration with applicable stakeholders, publishes a new Florida Transportation Plan every five years. The FDOT Central Office has also published the TSM&O plans shown in **Figure 2.1**, all of which include CAV technologies and applications. The TSM&O Strategic Plan was developed to support the advancement of transportation operations, safety,

Best Practice: District and regional TSM&O, CAV, and STAMP champions and stakeholders should provide input as the FTP and statewide TSM&O plans are developed to ensure District and Regional programs and priorities are reflected in statewide transportation and TSM&O planning.

mobility, innovation, and emerging transportation technology goals in the Florida Transportation Plan (FTP). The Statewide Arterial Management Program (STAMP) Action Plan provides guidance for TSM&O specific to signalized arterial roadways. Finally, the CAV Business Plan provided a roadmap for initiation of CAV activities within FDOT leading to full scale implementation.

2.3 District and Regional Planning Process Overview

Transportation planning at the district or regional level typically includes Long Range Transportation Plans (LRTPs) and programming plans such as TSM&O Implementation Plans.

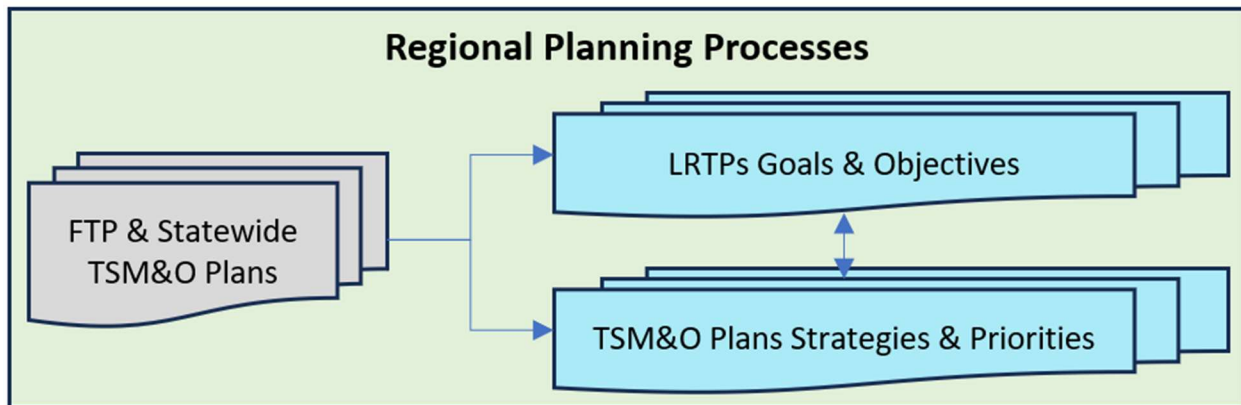

Figure 2-2: Visualization of Regional Planning Process

2.3.1 Long Range Transportation Plans

One role of Metropolitan and Transportation Planning Organizations (MPO/TPO) is to work with federal, state, regional, and local transportation organizations, and the public to develop an LRTP for the region. Updated on five-year cycles, LRTPs provide a framework of transportation, economic development, livability goals, and objectives to guide multi-modal transportation investments over the upcoming 20 to 25 years.

LRTPs typically identify transportation goals, objectives, and needs. With the success of ITS and other transportation technologies, LRTPs typically recognize and prioritize emerging technologies as a means of achieving safety and mobility for all road users, including vulnerable road users. For example, 41 of 121 projects in the [Sarasota/Manatee MPO 2026-2045 Cost Feasible Plan](#)^v are identified as ITS infrastructure, CV infrastructure, or ITS adaptive control projects in support of LRTP goals for safety/security, mobility/reliability, and technology/autonomy.

Best Practices: District and regional TSM&O, CAV, and STAMP champions and stakeholders should actively engage with MPO/TPO ITS/TSM&O committees and working groups to ensure:

- District and regional goals and objectives are reflected in LRTPs.
- TSM&O needs and project descriptions are high-level and avoid prescribing specific technologies, e.g., “traffic monitoring systems” rather than “closed-circuit television (CCTV),” allowing technology selection to occur later in the project development and systems engineering analysis.

2.3.2 Regional TSM&O Plans

FDOT Districts have worked with their MPO/TPO and local transportation organizations to develop districtwide or regional TSM&O Plans called Master Plans, Implementation Plans, or Strategic Plans. These plans typically have time horizons less than the LRTP but generally cover a 10-year timeframe. These plans usually follow a five-year update cycle involving many agencies that practice TSM&O. Beginning with the

2017 Statewide TSM&O Strategic Plan, CVs were identified as a TSM&O focus area and CAV projects began being introduced within TSM&O Plans. When including CAV, the TSM&O Plans should describe CAV technologies and potential applications that are priority for implementation in the region. Before completing the plan, it is suggested that practitioners and/or subject matter experts be engaged to ensure the feasibility/maturity of the proposed applications.

2.4 TSM&O Project Planning Overview

The three main components of project planning in FDOT are the TSM&O Cost Feasible Plan, the Regional ITS Architectures (RITSA), and the Five-Year Program Plan.

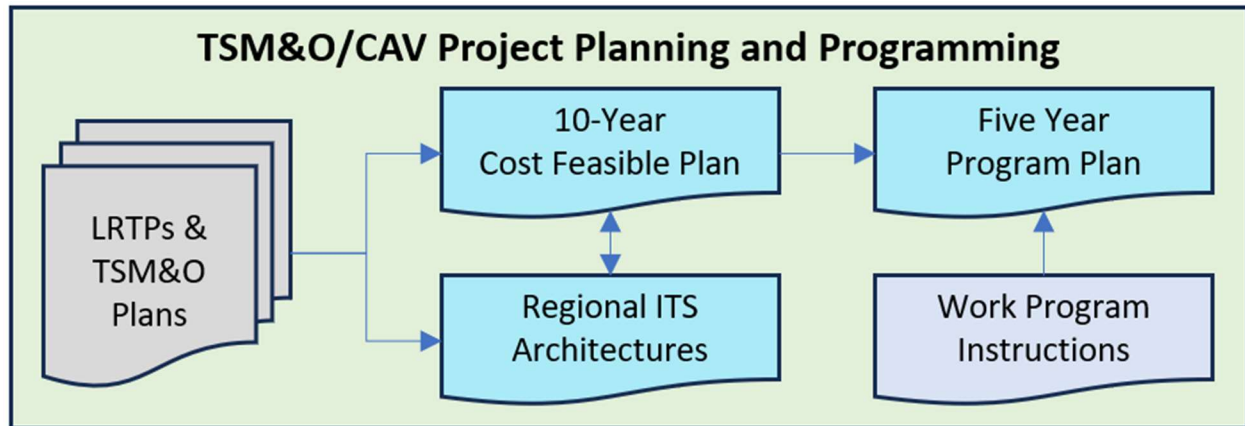

Figure 2-3: Visualization of TSM&O and CAV Project Planning Process

2.4.1 10-Year ITS Cost Feasible Plan

The 10-Year ITS Cost Feasible Plan (CFP) identifies CAV projects that were identified in the TSM&O Plans. Districts submit CAV projects to the Central Traffic Engineering and Operations Office (TEOO) for inclusion in the CFP. The CFP describes the project, identifies project phases (design, implementation, operations, etc.) by Florida Fiscal Year, provides preliminary cost estimates, and identifies the funding source or sources for each phase. Funding sources such as statewide ITS funds (aka, "DITS") are managed and allocated by TEOO. Depending on the strategy, other statewide funding may apply, like SIS Quick Fix, Safety, or Freight. Other funding sources are specific to and allocated within each district. Any of these sources can and should be considered when attempting to implement Regional TSM&O Plans.

Best Practices:

- District TSM&O, CAV, and STAMP champions and stakeholders should be engaged to review cost estimates for all phases.
- Method of acquisition should be determined prior to programming, including any coordination for approval.
- Cost Planning, PD&E, and/or design should include systems engineering work completed by consultant to be reviewed by the TSM&O Engineer or their designee.
- Construction costs should be programmed with operations, maintenance, and life-cycle replacement costs.

Cost estimates for systems engineering are proportional to the anticipated risk of the project. Cost estimates for emerging technologies with limited or no historical costs include appropriate contingency amounts for both design and construction.

2.4.2 Regional ITS Architectures

TSM&O programs or strategies, such as CAV technologies and applications, often require implementation, operations, and/or maintenance support from multiple organizations. FDOT Districts have worked with local transportation organizations to develop [Regional ITS Architectures](#)^{vi} (RITSAs). The RITSAs, also with a 10-year time horizon, are updated annually and include information on ITS projects, project stakeholders, ITS service packages, connectivity, and information flows between project elements. Each RITSA, while still essentially a planning tool, describes CAV technologies and applications or services in more technical detail than is appropriate for LRTPs or Regional Plans. RITSA is the bridge between planning, programming, and the Systems Engineering Analysis required for implementation of ITS and similar transportation technologies.

Best Practice: Including in the scope of TSM&O Regional Plans completion of RITSA updates insures timely and accurate updates to the architecture.

District TSM&O Engineers or their designee should ensure TSM&O/CAV projects in the Cost Feasible Plan are described in the RITSA.

Best Practice: District TSM&O, CAV, and STAMP champions and stakeholders should:

- Seek funding for TSM&O/CAV projects from the 10-year cost feasible plans in the new fifth year of the Five Year Work Program annually.
- Update project cost estimates as more details about emerging and CAV technologies and applications are available.

2.4.3 FDOT Five Year Work Program

In order for projects to be authorized to proceed to planning, PD&E, design, etc., they must be included in FDOT’s [Five Year Work Program](#).^{vii} The FDOT [Work Program Instructions](#)^{viii} guides all programming activities. It breaks down budgets by project phase and work type codes. CAV is included as an ITS work type code. CAV projects are currently listed in the FDOT Five Year Work Program. Following are two examples of CAV projects included in the Five-Year Work Program:

Table 2-1: Example of CAV Related Project in the Current 5-Year Work Plan

Project Summary						
Transportation System: NON-SYSTEM SPECIFIC			District 02 - St Johns County			
Description: SMART ST. AUGUSTINE CONNECTED VEHICLE SYSTEM IN CITY OF ST. AUGUSTINE			View Scheduled Activities			
Type of Work: ITS COMMUNICATION SYSTEM						
Item Number: 448653-3						
Project Detail						
Fiscal Year:	2024	2025	2026	2027	2028	2029
Miscellaneous/PD & E						
Amount:	\$357,789					
Miscellaneous/Preliminary Engineering						
Amount:	\$1,839,106					
Miscellaneous/Construction						
Amount:	\$13,613,443					
Item Total:	\$15,810,338					

Table 2-2: Example of CAV Related Project in the Current 5-Year Work Plan

Project Summary						
Transportation System: NON-SYSTEM SPECIFIC			Statewide - District Wide			
Description: CONNECTED AND AUTOMATED VEHICLES			CONTINGENCY			
Type of Work: ADV TRAVELER INFORMATION SYSTM			View Scheduled Activities			
Item Number: 443887-1						
Project Detail						
Fiscal Year:	2024	2025	2026	2027	2028	2029
Miscellaneous/Operations						
Amount:			\$562,500	\$562,500	\$562,500	\$562,500
Miscellaneous/Capital						
Amount:	\$1,114,110	\$750,000	\$562,500	\$562,500	\$562,500	\$562,500
Item Total:	\$1,114,110	\$750,000	\$1,125,000	\$1,125,000	\$1,125,000	\$1,125,000

2.5 Preliminary Project Development

Once a project is in the Five-Year Program Plan, CAV and other ITS projects are able to proceed to preliminary project development, including:

- Project Development and Environment (PD&E)
- Steps and Processes of the Systems Engineering Analysis

- **Best Practices:** District and regional TSM&O, CAV, and STAMP champions and stakeholders should: Recommend strategies to include in the TSM&O Alternative based on LRTP, 10-year cost feasible plan, and five-year work program.
- Communicate to PD&E the needs that the TSM&O alternative will address as input to whether the TSM&O alternative will meet the purpose and needs of the PD&E project.

2.5.1 PD&E Process and Scoping

FDOT’s [PD&E Manual](#)^{ix} provides guidance for project development and environmental studies necessary for transportation projects. Per Part 2, Chapter 2, Section 2.2.2, stand-alone TSM&O projects which includes CAV technologies and applications are generally considered Type 1 or Type 2 categorical exclusions and are excluded from the requirement to prepare an environmental assessment (EA) or an environmental impact statement (EIS).

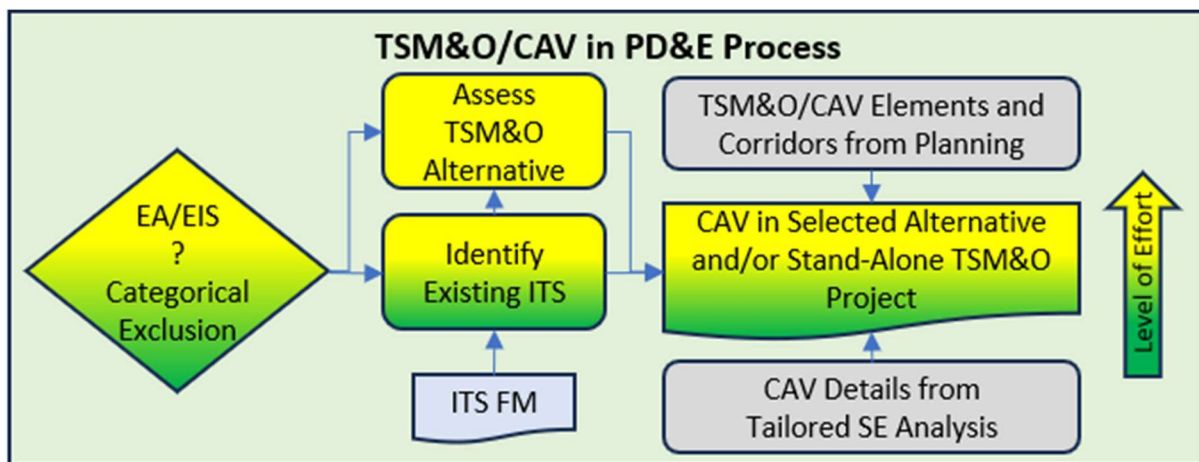

Figure 2-4: Visualization of TSM&O and CAV in the PD&E Process

Major transportation improvement projects that are covered by either an EA or EIS are required to perform an “Engineering Analysis” per Part 2, Chapter 3 of the PD&E Manual. The Engineering Analysis is required to consider ITS/TSM&O in the following ways:

- Existing Intelligent Transportation Systems/ Transportation Systems Management and Operations** (Section 3.2.3.3.4): Projects that involve ITS must include review of existing ITS documents, including Concept of Operations (ConOps) and Project Systems Engineering Management Plan (PSEMP), and plans to determine operational needs and infrastructure requirements. The FDOT ITS Facilities Management (ITS FM) is a resource for existing FDOT ITS underground and above ground ITS infrastructure. To ensure that all existing ITS and CAV field devices are identified early in the PD&E process, it is recommended that PD&E Team members including TSM&O, ITS, CAV, and STAMP managers, operators, and maintainers conduct a field review of the impacted roadway and Regional or Local Traffic Management Center.
- Transportation Systems Management and Operations Alternative** (Section 3.2.4.2): Major projects require an analysis of alternatives to the proposed project. As a minimum, the alternatives analysis must include a no-build alternative and a TSM&O alternative. The TSM&O Alternative includes strategies with the operational objective of preserving the capacity and improving the security, safety, and reliability of the transportation system, while minimizing environmental impacts. The TSM&O alternative, on its own, is usually unlikely to meet the overall purpose and need for the project.
- Stakeholder Engagement** can be utilized (Section 3.2) for interacting with a Maintaining Agency to get support and buy-in for the project, as well as conducting an initial Technology Capability assessment for the partner agencies. Keeping in mind that 23 CFR (Code of Federal Regulations) Part 940 specifies “systems engineering activities and what must be built to satisfy stakeholder needs,” including the maintainability of such systems and the technology capabilities needed to support and maintain a successful CAV project. The project’s overall budget may need to be updated with considerations of the technology needs of the stakeholders, particularly that of the Maintaining Agency.

Best Practice: The PD&E Team should actively engage District and regional TSM&O, CAV, and STAMP champions and stakeholders, including TSM&O operations and maintenance, in PD&E scoping and during alternatives analysis to ensure adequate consideration of TSM&O/CAV during the PD&E process.

- **Engineering Considerations for Build Alternatives, ITS** (Section 3.2.5.7): ITS elements including CV should be considered as part of the Build Alternatives in alignment with the proposed need of the Project. An ITS scope must be developed in accordance with FDOT’s Systems Engineering and ITS Architecture Procedure ([#750-040-003](#)). The Systems Engineering Analysis is tailored based on the risk and complexity of the ITS/CAV elements planned for inclusion in the selected build alternative.

Minor, stand-alone, or independent ITS projects that are Type 1 or Type 2 categorical exclusions are still subject to systems engineering analysis, see Section 2.5.2 - Tailored Systems Engineering Analysis.

Best Practice: TSM&O, CAV, and STAMP champions and PD&E should agree upon and document TSM&O/CAV elements that will be included in the major project Build Alternative and which elements will be implemented independently from the major project.

- Update the 10-year cost feasible plan and/or five-year work program for TSM&O/CAV elements carried forward as a stand-alone project(s).
- Include all phases of costs for TSMO improvement as part of any estimate.

2.5.2 Tailored Systems Engineering Analysis

The last project development step prior to final design, plans, specifications, and estimates is described in the FDOT Systems Engineering and ITS Architecture Procedure as the “decomposition phase.” This phase typically consists of a preliminary risk assessment and then development of preliminary Concept of Operations, PSEMP, and Requirement Traceability Verification Matrix (RTVM) documents with enough stakeholder coordination and detail to ensure the identified risks and complexity do not hinder successful implementation, operation, and maintenance of the TSM&O/ITS/CAV project elements.

For low risk projects, such as merely installing CAV RSUs on existing ITS or traffic signal infrastructure, the level of effort may only require completion of the Project Risk Assessment and Regulatory Compliance Checklist (FDOT Form [#750-040-05](#)). The Checklist should be prepared in accordance with FDOT [Instructions](#) for completing the form. More complex and high-risk projects require preparation of PSEMP, ConOps, and RTVM at a minimum. The FDOT project manager should confer with the District TSM&O Program Engineer, or designee, to verify the level of systems engineering analysis to be performed in conjunction with the PD&E.

Best Practices: District and regional TSM&O, CAV, and STAMP champions and stakeholders should:

- Actively participate in the TSM&O/CAV risk assessment to ensure appropriate tailoring of and budget for the Systems Engineering Analysis.
- For higher risk projects, ensure staffing and resources for operations, maintenance, and life-cycle replacement are addressed in the ConOps and PSEMP.
- Ensure local agency operations and/or maintenance are addressed, and necessary MOU and Agreements for connectivity and network access are developed and executed.

For low risk projects, systems engineering analysis is complete upon approval of the Project Risk Assessment and Regulatory Compliance Checklist and the project may proceed to design, see Section 3 – Design.

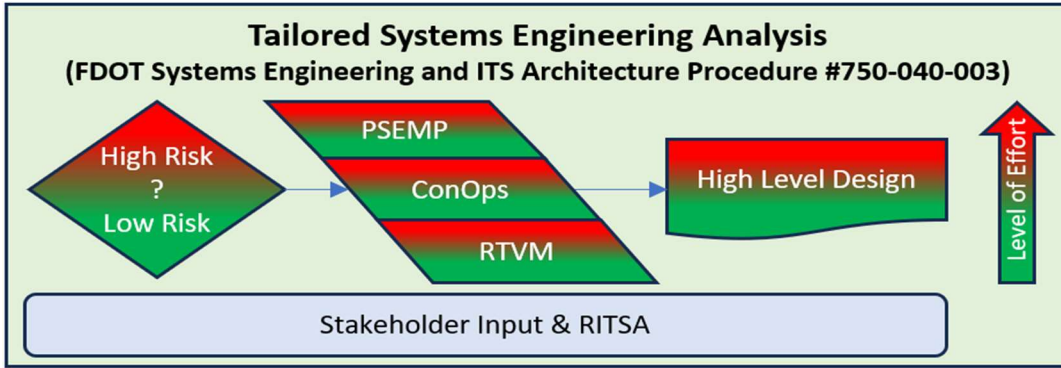

Figure 2-5: Visualization of Systems Engineering Analysis

2.6 Project Evaluation/Studies/Research

After implementing a CAV project, the Districts are encouraged to consider conducting a research or project evaluation study to document of the project’s intended goals achieved through safety and mobility improvements. By collecting, tracking, and analyzing data throughout projects, the impacts of CAV technology can be realized and recognized. FDOT Districts can coordinate with the State Traffic Engineering and Operations Office and [Research Center](#) to commission a research project.

^v Sarasota/Manatee MPO 2026-2045 Cost Feasible Plan : <https://www.mympo.org/files/32/Long-Range-Transportation-Plan/1117/DRAFT-CFP-9-10-2020.pdf>

^{vi} FDOT Regional ITS Architecture: <https://teo.fdot.gov/architecture/index.html>

^{vii} FDOT 5 Year Work Program <https://fdotewp1.dot.state.fl.us/fmsupportapps/workprogram/WorkProgram.aspx>

^{viii} FDOT Work Program Instructions

^{ix} FDOT PD&E Manual <https://www.fdot.gov/environment/pubs/pdeman/pdeman-current>

Section 3: Design Considerations

This chapter shares guidance and best practices concerning the analysis and design phase of projects including the deployment of CV equipment and technology. These guidelines are aimed at individuals responsible for the specific engineering efforts required to develop detailed release for Construction plans and specifications. The Engineer throughout this design chapter generally refers to the Design Engineer or Engineer-of-Record (EOR) preparing the CV plans, unless otherwise indicated as the Project Engineer/Project Manager or Construction Engineer. The following information in this Section should be considered as supplemental information to the *Florida Department of Transportation Design Manual (FDM)*, *Standard Plans for Road and Bridge Construction*, *Standard Specifications for Road and Bridge Construction*, *FDOT Developmental Specifications*, and *Traffic Engineering Manual*.

3.1 Preliminary Engineering Considerations

The first step in the design phase will be the completion of initial engineering activities used to identify the overarching goals and objectives and assess the existing conditions for the project if this has not been completed as part of a prior phase. This is a critical process for the successful delivery of CV deployments and includes efforts related to Systems Engineering, field reviews, and stakeholder coordination.

3.1.1 Systems Engineering Updates

Connected Vehicle deployments are complex, multi-system integrations leveraging various pieces of hardware, software, network, and cloud to transmit and receive real-time messages between transportation infrastructure vehicles and other road users. Connected Vehicle devices are usually considered to be ITS equipment. Similarly, projects that deploy CV equipment should follow the processes, procedures, and requirements associated with ITS deployments, including requirements associated with Systems Engineering. Using the Systems Engineering (SE) process will help mitigate complexity and associated risks by clearly defining the project management methodology to be used throughout the entire lifecycle, documenting project goals, and helping ensure that systems meet stakeholder needs, and the project remains on schedule and within budget.

The Department has created a comprehensive reference document providing guidance through the full SE process, Florida Department of Transportation Systems Engineering and Intelligent Transportation Systems (ITS) Architecture Procedure (750-040-003-d).^x Completing the SE process involves multiple steps including:

- *Project Risk Assessment and Regulatory Compliance Checklist* (form 750-040-005)
- Project Systems Engineering Management Plan (PSEMP)
- Concept of Operations Report (ConOps)
- System Testing and Validation Plan
- Requirements Traceability and Verification Matrix (RTVM)

Best Practice: The Engineer is encouraged to check with the District to see if existing/updated documents are available related to Systems Engineering for CV Deployments.

The Engineer is encouraged to coordinate with the District to determine if existing documents (i.e., ConOps) are available to be updated for the project specific needs. Where the project requires the development of new documentation, or if the existing documents are no longer current, templates for all documents are available at <https://www.fdot.gov/traffic/ITS/Projects-Deploy/SEMP.shtm>.

3.1.1.1 Project Risk Assessment and Regulatory Compliance Checklist

For each project, the Engineer is responsible for completing the **Project Risk Assessment and Regulatory Compliance Checklist** (form 750-040-05). While this document is a requirement for all federally funded projects involving ITS, it is recommended to be completed for all CV deployments. By completing this checklist, each project will be assigned as either a low-risk or a high-risk effort. This determination is based on seven attributes:

1. Single versus multiple jurisdictions or modes of transportation
2. Software development required
3. Maturity of proposed technologies
4. Development of new interfaces between systems
5. Level of details for system requirements
6. Established operating procedures
7. End-of-service life expectancy for technologies

Best Practice: A Project Risk Assessment and Regulatory Compliance Checklist is recommended to be completed for all Connected Vehicle deployments to determine associated efforts and risk.

The assigned level of risk will dictate the appropriate next steps to tailor the SE process and identify the minimum supporting documentation required for the project – including the PSEMP, ConOps, Systems Testing and Validation Plans, RTVM, and more. Other considerations also include age and condition of existing ITS or Signalization infrastructure where a CV deployment may be added. For example, older infrastructure might have insufficient structural capacity or spare conduit capacity or structural limitations.

Provide the completed *Project Risk Assessment and Regulatory Compliance Checklist* to the Department Project Manager to be uploaded with all project documents. For projects assigned as high-risk, coordinate with the Department to discuss the available mitigation strategies and develop a plan to successfully deliver the work.

3.1.1.2 ITS Architecture

The RITSA should be reviewed and updated as needed for each planned CV project. Florida includes a total of seven RITSAs. RITSA geographical boundaries are similar to the Department’s District boundaries (Districts Four and Six are combined) and the boundaries of Florida’s Turnpike Enterprise. The current version of each RITSA, as well as the Statewide ITS Architecture (SITSA), is available on the FDOT [Traffic Engineering and Operations Office](#) website.

As new projects are planned and novel applications are developed, the RITSA should be updated to reflect the changing conditions with respect to CV deployments. For each project, the following should be reviewed to verify the architecture is maintained and current:

- **Stakeholders** – verify that all associated private and public organizations responsible for the management and support of the systems, or otherwise impacted by the project, are clearly and uniquely identified.
- **Inventories** – ensure that all elements owned, operated, maintained, or planned for future deployment are identified for each stakeholder; verify the status of each element (i.e., “existing” or “planned”) is updated and accurate.

- **Service Packages** – viewed as the building blocks of an ITS deployment, Service Packages describe the specific functionality to be accomplished and define the interfaces and data flow exchanges between elements. Review the existing Service Package(s) relevant to project, especially those that specifically include CV elements, to determine if associated elements or interfaces require updates to match the proposed changes for the project.
- **Roles and Responsibility Areas** – determine if the specific requirements or level of involvement for each stakeholder will need to be updated to support the proposed system(s) – including operations, maintenance, funding, and more.
- **Agreements** – determine if new agreements between stakeholders are required, or if the existing agreement will need to be updated, to clearly define the responsibilities of each organization necessary for a successful integration. Examples include: what information will be exchanged between agencies and how, and delineation of maintenance responsibilities for shared or collocated equipment.
- **Projects** – the architecture should be used to capture all ongoing, planned, or future ITS projects described in terms of the similar system features and functionality. Where multiple projects share a common objective and similar technologies, it is commonplace to represent these efforts with a more “generic” project instead of individual, redundant project listings. Review the listed projects and ensure the proposed work is represented within a specific or generic project description.

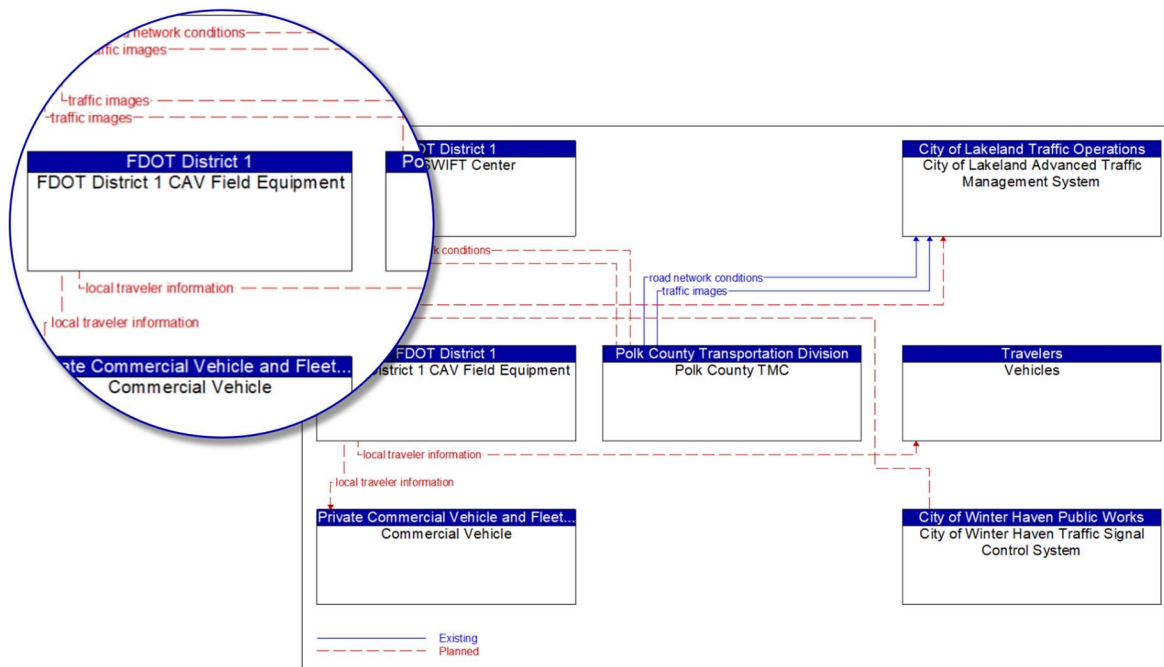

Figure 3-6: Example Service Package containing Connected Vehicle technology (I-4 FRAME, District One)

If the project is not captured in the current RITSA, then an update should be requested by either the Department as part of the project development phase or by the Engineer in the early stages of design. The Department has created a standard **ITS Architecture Change Request Form** (form 750-040-04) that must be completed for each proposed modification and is to be submitted electronically to both the District TSM&O Program Engineer and the State TSM&O Program Development Engineer (sysandarch@dot.state.fl.us). To complete this form, the author will need to provide general project background information, description of the proposed changes, reasoning behind the changes, impacted stakeholders, and any supplemental information to support the requested modifications. Use specific language and nomenclature from the existing architecture to describe the necessary updates – avoid generalized language that may be difficult to associate with a specific Service Package, Stakeholder, or Interface. Where the requested changes involve updates to Service Packages, it is recommended to provide a red-lined version of the existing Interconnect Diagram or Information Flow Diagrams graphic clearly identifying the proposed changes.

3.1.1.3 Project Systems Engineering Management Plan

Development of the PSEMP is a foundational activity for the successful implementation of a project involving ITS, including CV equipment and technology. The PSEMP is a technical document outlining the overall design and management process to be completed during the project lifecycle. This document, created by the Engineer, will provide high-level information including project background, details for how the SE process will be implemented, and strategies for the comprehensive management of the project.

Best Practice: Use the existing PSEMP template developed by the Department to maintain consistency between projects.

It is recommended to utilize the existing PSEMP template developed by the Department to maintain consistency between projects and to ensure all necessary information is provided.

3.1.1.4 Concept of Operations

The ConOps is a user-orientated document that provides a high-level understanding of how the proposed system(s) will function and the required involvement from project stakeholders. In simplified terms, the ConOps should describe the “who, what, when, where, why, and how” of the CV technology deployment, providing high-level requirements that allow users to define the expectations of the system. This document will be used as the framework to develop testable system requirements to allow verification throughout construction and integration.

The Department maintains a comprehensive ConOps template that is recommended for the development of new projects and includes specific sections necessary to identify the pertinent stakeholders and user needs; provide an overview of the existing conditions and the need for change; detail the proposed system architecture including hardware, software, interfaces, and data flows; define various operational scenarios to specify system functionality and user involvement, and more. The ConOps is intended to be an accessible document that is easily digestible by all audiences – technical and non-technical. Authors are encouraged to provide all detail necessary to present an understandable view of how the system(s) will function and how each will be maintained and operated – but remember, this document should be written in layman’s terms, where possible.

It is recommended that each CV deployment maintains an updated ConOps clearly defining the objectives and applications of the project. Answering the following questions will help ensure required information is included in the ConOps document:

“WHO...”

- Who are the project stakeholders?
- Who will be responsible for the operations and maintenance of the system(s)?
- Who is providing the funding for capital expenditures and recurring costs?

“WHAT...”

- What is the overall problem statement being addressed by this deployment?
- What are the specific user needs of each stakeholder?
- What are the intended Connected Vehicle applications proposed on this project?
- What hardware and software will be required to facilitate the necessary messaging and applications?
- What messages are being transmitted and received between the roadside infrastructure and vehicles?

“WHEN...”

- When will equipment need to be serviced, repaired, or replaced?
- When will different messages be transmitted and under what conditions?

“WHERE...”

- Where will roadside hardware and backend equipment be installed?
- Where will application-specific data be collected, stored, or processed?

“WHY...”

- Why are the proposed systems or applications required?

“HOW...”

- How will information be provided to road users in real-time?
- How will data be exchanged from one system to another?
- How will the systems function differently in various scenarios (e.g., normal operations, failed state, emergency)?

3.1.1.5 Application Function Diagrams

Provide a visual application function diagram for each proposed CV application included in the project. This is a simplistic graphic that clearly illustrates the individual components of the system architecture, as well as the data flows between systems, for the successful integration of the application. Application function diagrams should explain to the audience how information is generated, transmitted, and received by the end user with considerations for both roadside infrastructure (e.g., roadside units), in-

vehicle hardware (e.g., on-board units), and third-party external systems (e.g., mobile applications). Ensure that each application function diagram includes a Source List for the data required.

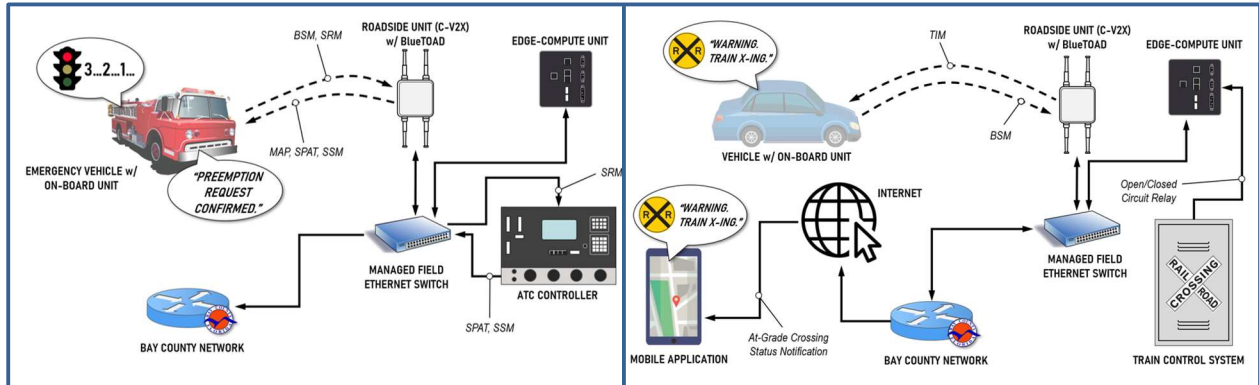

Figure 3-7: Example application function diagrams for Emergency Vehicle Preemption (left) and Railroad Crossing Violation Warning (right)

For projects with previously deployed CV applications under older legacy projects, pilots, or test cases, it is essential for the Engineer to develop a comprehensive CV Application inventory or diagram. This inventory should be communicated to the project owner and stakeholders, highlighting which existing CV applications may potentially be changed, updated, or removed. These changes may occur due to new CV deployments driven by modernization efforts, changes in standards, or the end-of-life cycle of older projects. This proactive communication ensures all parties are aware of the impact and necessary adjustments resulting from the new CV deployments.

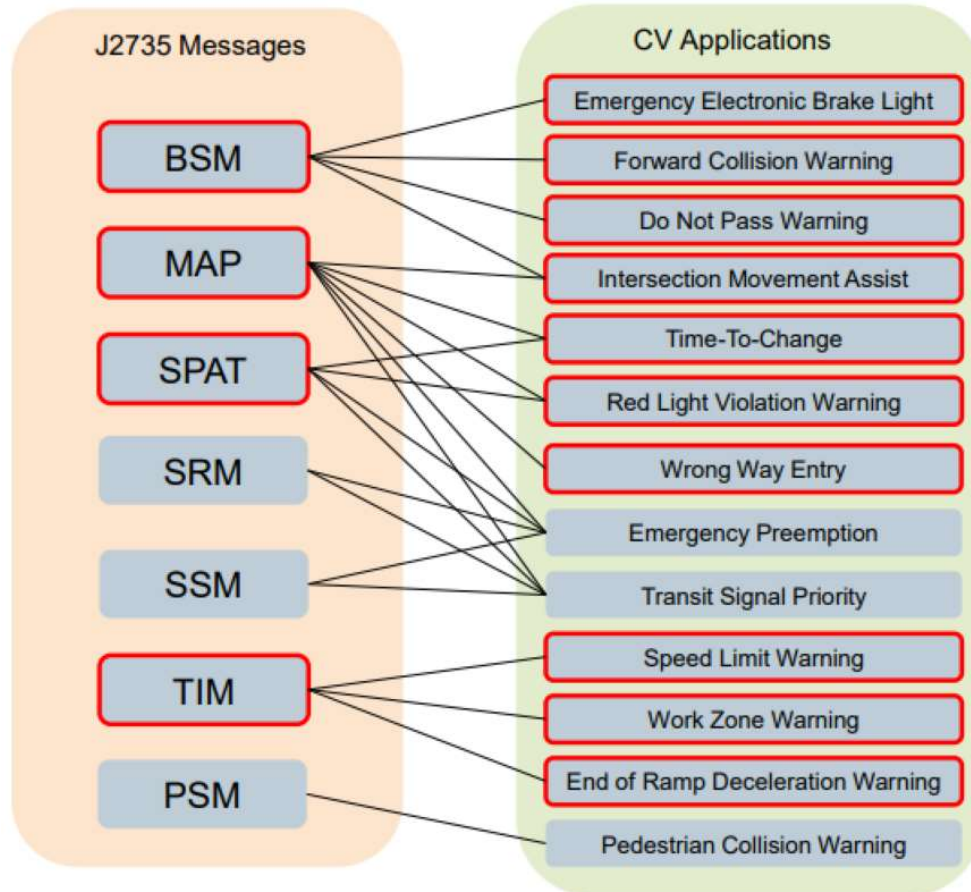

Figure 3-8: Illustration depicting the relationship between message and applications

3.1.1.6 Data Management

Data management, including estimation of data creation given existing communication and storage resources, should be carefully considered particularly when several devices produce the same exact data. For example, the exact same SAE J2735 (Society of Automotive Engineers) messages for Signal Phasing and Timing (SPAT), given a specific intersection could be shared and transmitted by the Traffic Signal Controller, the RSU, the IVP (Integrated V2I Prototype), and/or other field devices. If the same data is already being transmitted by one of the devices, the transmission of the same data by other devices should be turned off. It is important to consider data management and the potential for data duplication at the field device and deployment level so that multiple duplicate data sets are not transmitted to a central data repository (i.e., DEPOT). Some of the reasons why data duplication should be minimized or eliminated, when possible, include:

- Storage efficiency
- Cost savings both in transmission, storage, retrieval and processing
- Faster processing
- Data quality and consistency, implementation of data governance
- Data workflow efficiency
- Simpler and faster backup and disaster recovery
- Data privacy and compliance, particularly of government agencies needing to comply with Open Data and Public Records Laws (i.e., Florida Statutes 119)

- Scalability, compatibility considerations

If the involved Districts and local agencies do not have a specific project goal with the data generated from the CV devices, then the Vehicle-to-Everything Data Exchange Platform (DEPOT) should provide all adequate data management and use case support needed for a typical CV project in the state. The project just needs to ensure the data is being correctly routed to DEPOT.

3.1.1.7 Systems Testing and Validation Plan

The System Testing and System Validation Plans are typically multiple documents with similar purpose and objectives that are often grouped together for convenience. Used to establish the specific procedures and material necessary to certify the functionality of the deployed equipment, the Systems Testing Plan is typically comprised of three distinct levels of acceptance testing that further subdivide and describe the field installation testing and system testing described in FDOT specifications and required on projects.

- **Field Acceptance Testing (FAT)** – also referred to as “stand-alone testing” is the first component of field installation testing; this is a device-level test to confirm the individual components of the system are functioning properly and that the initial installation and configuration of devices has been properly completed. This procedure is focused on verifying proper physical installation, configuration, and basic function of field devices at the site of the installation and each device is tested individually without reliance on other system components. Most activities will be completed using only a locally connected laptop. For example:
 - Verify that physical construction has been completed as detailed in the Plans.
 - Verify RSU is mounted firmly and does not move or rotate.
 - Verify RSU is properly grounded.
 - Verify RSU mounting height and location is as identified in the FCC site registration.
 - Verify all wire and cable connections are correct and secure.
 - Verify all cabling provides drip loops.
 - Verify all device ports are sealed and watertight.
 - Verify proper voltages for all power supplies and related power circuits.
 - Connect devices to power sources.
 - Verify RSU is operational.
 - Verify the power LEDs on roadside equipment illuminates.
 - Log in to CV equipment and verify access to user interface.
 - Verify factory default username and password are provided.
 - Verify the configuration of CV equipment network interfaces.
 - Verify RSU provides physical network connection and is configured with appropriate IP address, default gateway, and other network parameters.
 - Verify successful *PING* of RSU at default settings.
 - Verify accuracy of system time.
 - Verify that there is a MapData file loaded on the RSU, or other store and repeat messages, as appropriate.
- **Subsystem Acceptance Testing (SSAT)** – SSAT is the next step in field installation testing following successful completion of the FAT. This testing is used to verify that all field system components have been installed and integrated with the organization’s network properly. During SSAT, field installation testing is expanded to confirm data flows between various devices of the system are occurring properly. This test is often performed at the installed site using a remote login, as

appropriate. The testing procedures should include a review of the data transmitted and received from the system for accuracy and completeness. The following provides example SSAT activities, dependent upon the specific applications and functionality of the system.

- Verify MAP transmission.
 - Verify MAP data is being broadcast by RSU (e.g., receipt and display of messages on OBU or appropriate testing tool).
- Verify SPAT transmission.
 - Verify controller is transmitting SPAT to RSU.
 - Verify SPAT broadcast from RSU.
- Verify Basic Safety Message (BSM) receipt and forwarding.
 - Verify RSU receives and forwards BSMs.
- Verify Traffic Information Message (TIM) transmission.
 - Verify TIM broadcast from RSU. *Note, at this stage of testing TIM generation can be manually completed using laptop connected locally.*
- Verify Emergency Vehicle Preemption (EVP) / Transit Signal Priority (TSP) application.
 - Verify RSU receives Signal Request Message (SRM) from OBU.
 - Verify controller receives high-priority request from RSU, executes preemption sequence, and reverts to normal operations as programmed
 - Verify RSU receives Signal Status Message (SSM) from controller.
 - Verify OBU receives SSM broadcast from RSU.
- **System Acceptance Testing (SAT)** – the final stage of acceptance testing is performed on the entire system to verify the end-to-end integration and functionality of all components. System Testing includes verifying all field devices are configured and operational. This includes verifying that CV equipment included in the overall project is fully functional within the SunGuide central software platform and other central software, as appropriate, and each device is properly enrolled within the statewide Security Credentials Management Systems (SCMS). The following provides example SAT activities and should be modified to address the specific applications and functionality for the project.
 - Verify communications between field equipment and central network (e.g., TMC).
 - Verify RSU is integrated into SunGuide central software platform, as applicable.
 - Verify RSU is integrated into other software systems, as applicable (e.g., vendor provided cloud-based systems, etc.).
 - Verify CV application functionality through drive testing.
 - Verify SPAT information is accurate and matches intersection operations.
 - Verify TIM generated by SunGuide is broadcast by RSU and received by OBU.
 - Verify RSU is receiving certificate top-offs from statewide SCMS.
 - Verify data forwarding and connectivity with other third-party systems (e.g., DEPOT).

Best Practice: The Project Manager and/or the Contractor should verify that the RSUs have been pre-enrolled by the manufacturer to the statewide SCMS prior to field installation.

The Engineer will be responsible for defining all the necessary materials and procedures to complete each stage of testing for the proposed CV hardware within the Systems Testing Plan.

The Systems Validation Plan outlines the manner in which stakeholders will determine whether or not the constructed systems satisfy the identified user's needs. Viewed as partner documentation, the Systems Validation Plan provides the specific performance metrics to validate the functionality and system requirements defined within the ConOps through objective evidence.

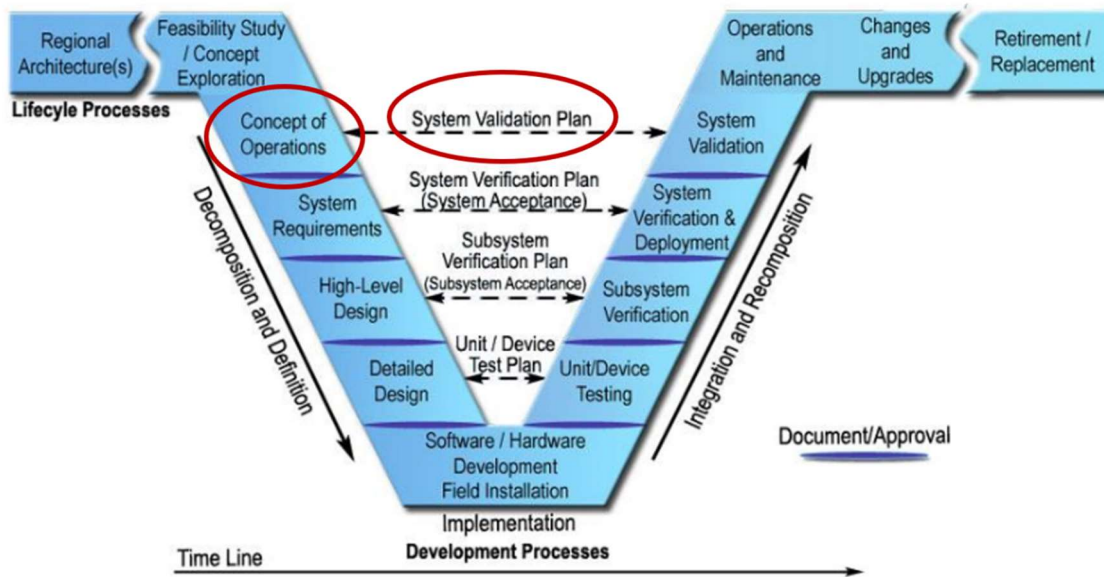

Figure 3-9: Relationship between the ConOps and the System Testing and Validation Plan

3.1.1.8 Requirements Traceability and Verification Matrix

Setting up an RTVM provides a tool that clearly defines the relationship between project requirements and how each will be tested and verified. It is recommended to focus the RTVM on high-level objectives and the functionality of the proposed systems, and not include each technical detail within the project. This tool is not intended to replicate the specifications. Instead, the RTVM should be utilized to monitor the progress of the project to accomplish the unique goals and include identification of specific user needs, how these user needs are defined in the contract documents, and whether these requirements were successfully completed.

The Department maintains a well-defined RTVM template with detailed instructions and guidance on how to complete the document.

REQUIREMENTS TRACEABILITY VERIFICATION MATRIX										
Project Name:		I-75 Florida's Regional Advanced Mobility Elements								
Project Description:		Connected Vehicle equipment installation on I-75 and numerous arterial corridors in Alachua County, FL								
Project Manager Name:		Pete Vega								
Agency/Firm:		AtkinsRealis								
User Need ID	User Need Summary	Detailed Requirement ID	Detailed Requirement Summary	Document Section	DR Source Document	Verification Test Case ID	Compliance (Y/N/Partial/NA)	Notes/Comments/Date	Reviewer Initials	FDOT Initials
UN009	Provide real-time Signal Phase and Timing (SPAT) information to motorists.	DR001	Furnish and install C-V2X Roadside Units at signalized intersections capable of transmitting SPAT.	T681	TSP	TC015	Yes	RSU provided meets the SAE J2735 standard. Verified using testing-level OBU.	RM	
UN009	Provide real-time Signal Phase and Timing (SPAT) information to motorists.	DR002	Install C-V2X SPAT module within controller assembly.	671	MSP	TC007	Yes	Software module add-on to controller purchased, integrated by vendor.	RM	
UN012	Collect real-time positional information for vehicle - including location, speed, heading.	DR003	Furnish and install C-V2X Roadside Units capable of receiving Basis Safety Messages (BSM).	T68-1	TSP	TC001	Yes	RSU provided meets the SAE J2735 standard. Verified using testing-level OBU.	RM	

Figure 3-10: Example RTVM using the adopted Department template.

3.1.2 Field Reviews

Determining the pre-build conditions is a critical aspect of the design process for the deployment of CV systems. Designers should be responsible for performing on-site field reviews to identify the existing conditions for network communications, available power, physical structures, cabinets and enclosures,

existing field devices and in-cabinet equipment, associated aboveground and underground infrastructure, and surrounding conditions such as urban canyons, vegetation, line of sight obstructions.

During the field reviews, it is recommended that the Engineer document the existing conditions through timestamped photographs and field notes. Prior to performing field reviews, the Engineer should request any available as-built information from the Department and/or the local maintaining agency – including as-built plans, structural inspection reports, and more.

NOTE: Unless otherwise determined on an as-needed basis by the Department, the Engineer will not be responsible for conducting a spectrum analysis to determine any existing sources of out-of-band emission that can interfere with CV equipment operating in the 5.9-GHz (Gigahertz) V2X safety frequency within the project limits.

3.1.2.1 Communications

CV systems require reliable, high-speed communications to successfully exchange data between field devices and backend systems (e.g., SCMS, SunGuide). The Engineer will be responsible for determining the availability of communications between the proposed installation site and either the Department or the maintaining agency’s network. For arterial roadways, it is important to remember that access to the end point destination may require leveraging a separate network – for example, the installation of RSUs along a signalized corridor in District Six (within the Miami-Dade County) may need to first route information across the network of Miami-Dade County before reaching the Department. This requires the Engineer to gather information on all pertinent networks between the field installation site and the final destination.

During field visits, the Engineer will be responsible for identifying the following information.

Table 3-3: Field Review Questionnaire - Communications

(1)	Is the proposed site currently connected to an active network?	<input type="checkbox"/> Yes	<input type="checkbox"/> No
(1a)	If (1) is “Yes”, identify the maintaining agency for the network.		
(1b)	If (1) is “Yes”, identify the current network communication medium.	<input type="checkbox"/> Fiber Optics <input type="checkbox"/> Cellular Modem <input type="checkbox"/> Point-to-Point Wireless <input type="checkbox"/> Twisted-Pair	
(2)	If (1) is “No”, is existing network communications available within the immediate vicinity of the project limits?	<input type="checkbox"/> Yes	<input type="checkbox"/> No
(2a)	If (2) is “Yes”, identify the maintaining agency for the network.		
(2b)	If (2) is “Yes”, identify the current network communication medium.	<input type="checkbox"/> Fiber Optics <input type="checkbox"/> Point-to-Point Wireless	
(3)	Does the proposed site currently include a working network switch?	<input type="checkbox"/> Yes	<input type="checkbox"/> No
(3a)	If (3) is “Yes”, how many copper (RJ-45) ports are available in the switch? Identify if any available ports in the switch are designated as shared ports.		
(3b)	Identify the data transfer rate for copper (RJ-45) ports (e.g., 10/100). Identify the data transfer rate for fiber optic or SFP ports.		
(4)	Determine the available signal strength of the cellular network – preferably using a device either on the AT&T or Verizon network.		

When conducting field reviews, document all existing in-cabinet hardware – including the quantity, manufacturer, model, and functional status of all network equipment at the site. It is not unusual to discover legacy or unused equipment located within cabinets – including fiber optic patch panels and switches. The easiest way to ensure each device is actively powered on and communicating is to verify the LEDs for “POWER” are illuminated, and “LINK” is flashing. Where fiber optic patch panels are present, ensure jumper connections exist between the connector panel and active networking equipment. Patch panels without jumpers should be presumed to be inactive.

For point-to-point wireless communications, location of the wireless antennas should be carefully documented, and overall point to point system should be investigated, including adjacent nodes to each project location that may be outside of project limits. Elevation of existing and proposed antennas should be verified within project limits and all immediately adjacent nodes to ensure designer can reestablish communications.

For locations where networking switches exist, document the total number and type of ports, as well as the number of ports available for use. Document the utilization of all ports within the switch identifying the specific end device or connected system for each port. Identify if the existing switch includes any “shared” ports in which two physical port interfaces are paired together and only one port can be active at a time. Shared ports should be counted as a single port within the switch. Typically, users are able to identify shared ports by arrows or lines designating the shared interfaces. Ensure the switch provides the ultimate port availability to accommodate all of the existing devices and proposed systems (e.g., RSU, edge-compute device), as well as minimum of one spare port to facilitate local maintenance and configuration. The Engineer is required to coordinate with the maintaining agency to identify any potential projects, upgrades, or improvements that might impact the port availability to account for in the design. Where insufficient port availability exists, replace the switch with coordination through the local agency ensuring compatibility with existing network architecture. Be cognizant of proprietary products requesting upgraded switches which might cause compatibility issues with existing network speeds.

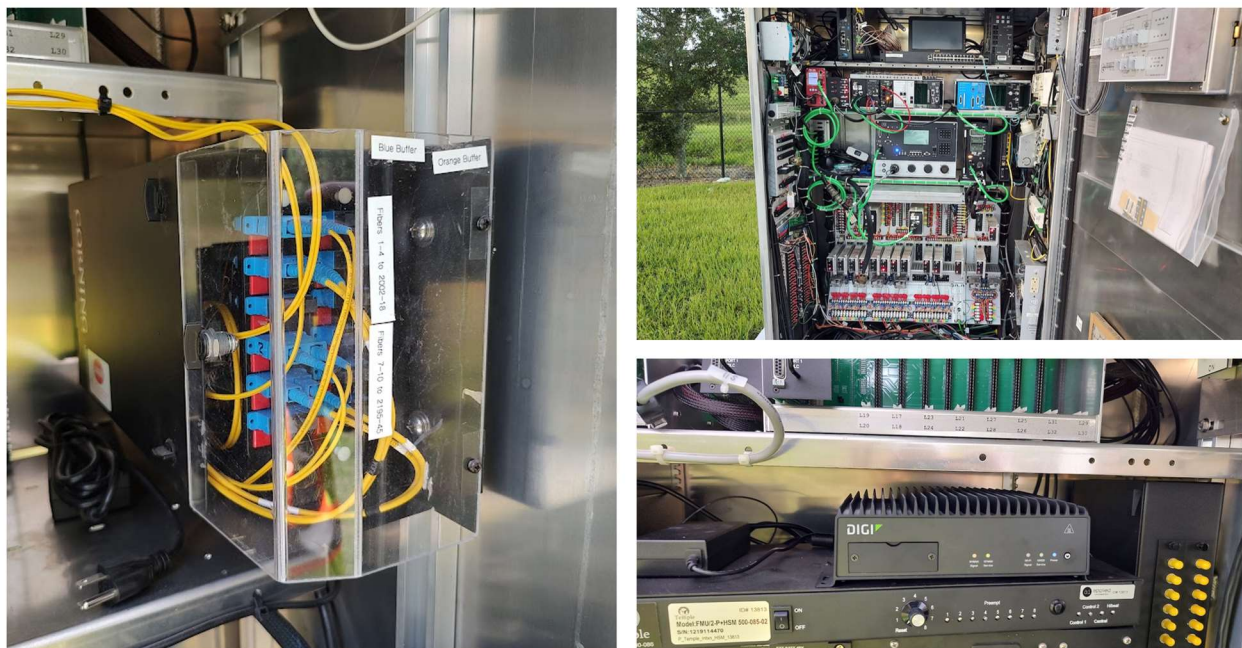

Figure 3-11: Examples of different networking communication equipment

3.1.2.2 Power

The Engineer will be responsible for determining the availability of power at each site location. Clean, reliable power is required for ensuring the continued operations of CV infrastructure and includes shoreline power connections, solar-power arrays, and battery backup systems. For existing sites, the Engineer will need to conduct a comprehensive field review to determine the presence and status of all electrical subsystem components to determine how the site is currently energized, whether or not the site is capable of powering additional devices, if the equipment is properly grounded, and more. Where new sites are proposed, the Engineer will need to identify potential electrical service connection points (e.g., utility poles, transformers) in the immediate vicinity or if an existing electrical service can be re-utilized.

During field visits, the Engineer will be responsible for identifying the following information.

Table 3-4: Field Review Questionnaire – Power

(1)	Verify whether power is provided to the existing site currently.	<input type="checkbox"/> Yes	<input type="checkbox"/> No
(1a)	If (1) is “Yes”, identify the electrical utility agency owner.		
(1b)	If (1) is “Yes”, identify the current power source type.	<input type="checkbox"/> Direct (grid) <input type="checkbox"/> Solar (off-grid)	
(2)	If (1) is “No”, is existing utility electrical service available within the immediate vicinity of the project limits?	<input type="checkbox"/> Yes	<input type="checkbox"/> No
(2a)	If (2) is “Yes”, identify the electrical utility agency owner.		
(2b)	If (2) is “Yes”, identify the physical infrastructure for the existing electrical service connection.	<input type="checkbox"/> Underground <input type="checkbox"/> Overhead	
(2c)	If (2) is “Yes”, confirm the incoming voltage of the available electrical service (in volts).	_____ Volts	
(2d)	If (2) is “Yes”, identify the phase of the available electrical service.	<input type="checkbox"/> Single-Phase <input type="checkbox"/> Three-Phase	
(4)	If (1b) is “Direct (grid)”, identify the existing infrastructure components for the electrical subsystem.	<input type="checkbox"/> Service Meter <input type="checkbox"/> Step-Down Transformer <input type="checkbox"/> Step-Up Transformer <input type="checkbox"/> Service Disconnect <input type="checkbox"/> Main Disconnect <input type="checkbox"/> Generator	
(5)	If (1b) is “Solar (off-grid)”, identify the existing infrastructure components for the solar-power array	<input type="checkbox"/> Solar Panels <input type="checkbox"/> Solar Controller <input type="checkbox"/> Batteries	
(5a)	Identify the operating voltage (V) and total wattage (W) of the solar panel array, as well as whether the panels are wired in series, parallel, or a combination of series and parallel.	_____ Voltage _____ Watts (Total) <input type="checkbox"/> Wired in Series <input type="checkbox"/> Wired in Parallel <input type="checkbox"/> Wired in Series - Parallel	
(5b)	Identify the operating voltage (V) and total wattage (W) of the battery array, as well as whether the batteries are wired in series, parallel, or a combination of series and parallel.	_____ Voltage _____ Watts (Total) <input type="checkbox"/> Wired in Series <input type="checkbox"/> Wired in Parallel <input type="checkbox"/> Wired in Series - Parallel	

(6)	If (1) is “Yes”, identify the existing in-cabinet equipment related to the electrical subsystem.	<input type="checkbox"/> Main Power Panel <input type="checkbox"/> Power Strip (RPMU) <input type="checkbox"/> Power Strip (Standard) <input type="checkbox"/> UPS w/ Batteries <input type="checkbox"/> Auto Transfer Switch
(6a)	If the selection for (6) includes “Main Power Panel”, identify the main circuit breaker rating (in amps).	_____ Amps
(6b)	If the selection for (5) includes “Power Strip (RPMU)”, identify the total number of plugs and the number of available plugs for future use.	_____ Total Available
(7)	Verify whether the existing cabinet is properly grounded.	<input type="checkbox"/> Yes <input type="checkbox"/> No

When conducting field reviews, document all existing in-cabinet equipment and field hardware related to the power subsystem – including the quantity, manufacturer, model, and functional status of each component. It is recommended that the Engineer identify the current field devices and components powered at the site to determine the approximate power draw and ability to add devices within the maximum power rating.



Figure 3-12: Example power infrastructure components including in-cabinet equipment (left) and infrastructure (right)



Figure 3-13: Example solar-powered system and internal components

3.1.2.3 Structures

Structural elements include all permanent aboveground infrastructure upon which CV equipment is physically installed – including overhead sign structures, mast arms, strain poles, span wire assemblies, and more. The Engineer will be responsible for verifying the viability of re-utilizing existing structures with consideration for physical condition, availability of space, conflict with existing devices, necessary mounting height, and more.

Table 3-5: Field Review Questionnaire – Structures

(1)	Verify if the existing site includes roadside structures.	<input type="checkbox"/> Yes	<input type="checkbox"/> No
(1a)	If (1) is “Yes”, identify the structure type(s).	<input type="checkbox"/> Steel Device Pole <input type="checkbox"/> Concrete Device Pole <input type="checkbox"/> Overhead Sign Structure <input type="checkbox"/> Steel Mast Arm <input type="checkbox"/> Concrete Span Wire <input type="checkbox"/> Monotube Structure <input type="checkbox"/> Overhead Truss <input type="checkbox"/> Multi-Column Sign <input type="checkbox"/> Other: _____	
(2)	If (1) is “No”, confirm the existing site location suitable to accommodate a new structure installation.	<input type="checkbox"/> Yes	<input type="checkbox"/> No

(2a)	If (2) is “No”, identify the potential concerns for installation of new structure. Right-of-way limits Existing utilities (i.e., overhead, underground) Environmental concerns (e.g., wetlands, threatened species, cultural and historic preservation) Clear zone – horizontal offset Limited available space (e.g., walls, drainage)		
(3)	Identify the relative condition of the existing structure, as determined through on-site visual inspection.	<input type="checkbox"/> Good <input type="checkbox"/> Fair <input type="checkbox"/> Poor	
(3a)	Identify if the structure contains horizontal or longitudinal cracking.	<input type="checkbox"/> Yes	<input type="checkbox"/> No
(3b)	Identify if the structure contains significant rusting or corrosion.	<input type="checkbox"/> Yes	<input type="checkbox"/> No
(3c)	Identify if the structure contains obvious impact damage.	<input type="checkbox"/> Yes	<input type="checkbox"/> No
(3d)	Identify if the structure upright is leaning or off-plumb.	<input type="checkbox"/> Yes	<input type="checkbox"/> No
(3e)	Identify if the structure contains anchor bolts that have been removed, do not provide a minimum of two thread beyond the top nut, loose, skewed, or missing lock nuts or washers.	<input type="checkbox"/> Yes	<input type="checkbox"/> No
(4)	If (1a) contains either “Steel Mast Arm” or “Overhead Sign Structure”, verify the anchor bolt pattern matches the latest version of Standard Plans.	<input type="checkbox"/> Yes	<input type="checkbox"/> No
(5)	If (1) is “Yes”, identify the existing attachments on the structure, as well as the mounting height and horizontal placement of each.	(1) (2) (3) (4) (5) (6)	
(6)	If (1) is “Yes”, identify the number of conduit sweeps entering into the structure and the total number of available spares.	_____	Total Available

As part of the field review, the Engineer is responsible for determining the present condition of structural elements – specifically to determine if the existing structure is suitable for the installation of additional field devices. When conducting assessments for existing structures, the following criteria is recommended to determine the current physical condition:

- **Good** – Element is intact and structurally sound with limited to no cosmetic imperfections. The structure needs no major repair other than routine maintenance (e.g., cleaning, touch-up paint).
- **Fair** – Structure shows early signs of wear, deterioration, or failure – such as cracking or rust. The element is generally structurally sound and performing its intended purpose. The structure requires minor repair efforts.
- **Poor** – Structure is no longer performing its intended purpose and shows signs of imminent failure. Elements show distinct signs of deterioration and damage. The structure requires major repair or replacement efforts.

Coordinate with the Department to obtain as-built drawings for the existing structures whenever possible.



Figure 3-14: Examples of various roadside unit mounting scenarios

3.1.2.4 Cabinets, Enclosures, and Field Devices

Cabinet assemblies include the physical housing, and all internal equipment required to perform the specific functions or applications at an installation site. Each assembly is typically unique with in-cabinet equipment varying per location to achieve the objectives of a signalized intersection or freeway management system. The Engineer will be responsible for determining the existing conditions of each cabinet assembly, as well as all discrete components and hardware that comprise the entire system. Cabinet assemblies are subdivided into two primary categories: traffic signal control cabinets and ITS cabinets.

Table 3-6: Field Review Questionnaire – Signalized Intersection Equipment

(1)	Verify if the existing site includes an existing traffic signal controller cabinet assembly.	<input type="checkbox"/> Yes	<input type="checkbox"/> No
(2)	If (1) is “Yes”, identify the governing standard of cabinet assembly.	<input type="checkbox"/> ATC <input type="checkbox"/> NEMA (TS-1, TS-2) <input type="checkbox"/> Caltrans (170/2070) <input type="checkbox"/> Other: _____	
(2a)	If (2a) is “NEMA (TS-1, TS-2)”, identify the standard cabinet size.	<input type="checkbox"/> 4 (24”W x 46”H x 16”D) <input type="checkbox"/> 5 (30”W x 48”H x 16”D) <input type="checkbox"/> 6 (44”W x 52”H x 24”D) <input type="checkbox"/> 7 (44”W x 72”H x 24”D)	
(2b)	If (2a) is “Caltrans (170/2070)”, identify the standard cabinet size.	<input type="checkbox"/> Type 332 <input type="checkbox"/> Type 333 <input type="checkbox"/> Type 552 <input type="checkbox"/> Type 662	

(3)	Document the manufacturer and model of the controller unit.	Manufacturer: <hr/> Model: <hr/>
(3a)	Identify the form factor type of controller unit.	<input type="checkbox"/> NEMA TS-1 <input type="checkbox"/> NEMA TS-2, Type 1 <input type="checkbox"/> NEMA TS-2, Type 2 <input type="checkbox"/> Caltrans 170/170E/179 <input type="checkbox"/> Caltrans 2070 / 2070E / 2070LX <input type="checkbox"/> Hybrid 2070/TS-2 Type 2
(3b)	Identify the current firmware version of the controller unit.	
(3c)	Identify all specific software applications and modules uploaded to the controller unit.	(1) (2) (3) (4) (5)
(4)	Identify the manufacturer and model of the Malfunction Management Unit (MMU) or Conflict Monitor Unit (CMU).	Manufacturer: <hr/> Model: <hr/>
(5)	Identify the type(s) of vehicle detection systems present within the intersection for stop bar detection (presence), as applicable.	<input type="checkbox"/> Inductive Loops <input type="checkbox"/> Microwave Radar <input type="checkbox"/> Video (standard) <input type="checkbox"/> Thermal Imaging <input type="checkbox"/> Wireless Magnetometer <input type="checkbox"/> Other (e.g., hybrid) <input type="checkbox"/> n/a
	Identify the type(s) of vehicle detection systems present within the intersection for advanced detection (pulse).	<input type="checkbox"/> Inductive Loops <input type="checkbox"/> Microwave Radar <input type="checkbox"/> Video (standard) <input type="checkbox"/> Other (e.g., hybrid) <input type="checkbox"/> n/a
	Identify the type(s) of vehicle detection systems present within the intersection for exit count detection, as applicable.	<input type="checkbox"/> Inductive Loops <input type="checkbox"/> Microwave Radar <input type="checkbox"/> Video <input type="checkbox"/> Other (e.g., hybrid) <input type="checkbox"/> n/a
(5a)	If (5) is "Microwave Radar", identify the manufacturer and model of the in-cabinet system, as well as the total number of sensors.	Manufacturer: <hr/> Model: <hr/> No.: <hr/>
(5b)	If (5) is "Video", identify the manufacturer and model of the in-cabinet system, as well as the total number of sensors.	Manufacturer: <hr/> Model: <hr/>

		No.:	_____
(5c)	If (5) is "Thermal Imaging", identify the manufacturer and model of the in-cabinet system, as well as the total number of sensors.	Manufacturer: Model: No.:	_____ _____ _____
(5d)	If (5) is "Wireless Magnetometer", identify the manufacturer and model of the in-cabinet system, as well as the total number of sensors.	Manufacturer: Model: No.:	_____ _____ _____
(5e)	If (5) is "Other", identify the manufacturer and model of the in-cabinet system, as well as the total number of sensors.	Manufacturer: Model: No.:	_____ _____ _____
(6)	Identify whether or not the intersection includes hardware for special operations (e.g., emergency vehicle preemption, transit signal priority).	<input type="checkbox"/> Yes	<input type="checkbox"/> No
(6a)	If (6) is "Yes", identify the operational function of the hardware, manufacturer and model of the system, and the total number of sensors.	Function: Manufacturer: Model: No.:	_____ _____ _____ _____
(7)	Identify the total number of detection channels available within the controller cabinet assembly.	<input type="checkbox"/> 16 channels <input type="checkbox"/> 32 channels <input type="checkbox"/> 48 channels <input type="checkbox"/> 64 channels	
(7a)	Identify the total number of bus interface units (BIUs) or serial interface units (SIU) present within the controller cabinet assembly, as applicable.	<input type="checkbox"/> BIU: _____ <input type="checkbox"/> SIU: _____ <input type="checkbox"/> n/a	
(7b)	Identify the total number of detector card slots within the controller cabinet assembly, as well as how many are available.	Total: Available:	_____ _____
(7c)	Identify the total number of Synchronous Data Link Communications (SDLC) interfaces within the SDLC bus of the traffic controller cabinet and how many interfaces are available.	Total: Available:	_____ _____
(7d)	Identify the total number of channels available on the detector panel within the controller cabinet assembly, as well as how many are available.	Total: Available:	_____ _____

(7e)	Identify the total number of active load switches within the controller cabinet assembly, as well as how many are available	Total: _____ Available: _____
(8)	Identify the available power source(s) within the controller cabinet assembly.	<input type="checkbox"/> Power Strip (standard) <input type="checkbox"/> RPMU (network-enabled) <input type="checkbox"/> Outlet Box <input type="checkbox"/> GFCI
(8a)	Identify the number of total and available power outlets within the controller cabinet assembly.	Total: _____ Available: _____
(8b)	If (8) is "RPMU (network-enabled)", identify the manufacturer and model of the remote power management unit (RPMU).	Manufacturer: _____ Model: _____
(9)	Identify if the controller cabinet assembly includes an uninterruptible power supply (UPS) and battery backup.	<input type="checkbox"/> Yes <input type="checkbox"/> No
(9a)	If (9) is "Yes", identify the manufacturer and model of the UPS, as well as the installation date of the batteries.	Manufacturer: _____ Model: _____ Date: _____
(10)	Identify if the existing cabinet includes available physical space for additional in-cabinet components.	<input type="checkbox"/> Yes <input type="checkbox"/> No
(11)	Identify the total number of conduit sweeps, and their respective diameter (e.g. 2", 3"), into the cabinet foundation.	Number: _____ Diameter: _____
(11a)	Identify the number of spare conduits, as well as the utilization of each conduit (e.g., low-voltage, high-voltage, fiber optic, electrical service).	No. _____ (low-voltage) No. _____ (high-voltage) No. _____ (fiber optics) No. _____ (electrical)
(11b)	Identify the number of conduits with available capacity, as well as the utilization of each conduit (e.g., low-voltage, high-voltage, fiber optic, electrical service).	No. _____ (low-voltage) No. _____ (high-voltage) No. _____ (fiber optics) No. _____ (electrical)
(12)	Identify if the signalized intersection includes supplemental field devices. For each field device identify the manufacturer and model. CCTV Camera Bluetooth Travel Time Reader Connected Vehicle Roadside Unit (RSU) Intersection Movement Count (IMC) Camera	Device Type: _____ Manufacturer: _____ Model: _____ <hr/> Device Type: _____ Manufacturer: _____ Model: _____

		Device Type: _____ Manufacturer: _____ Model: _____
		Device Type: _____ Manufacturer: _____ Model: _____

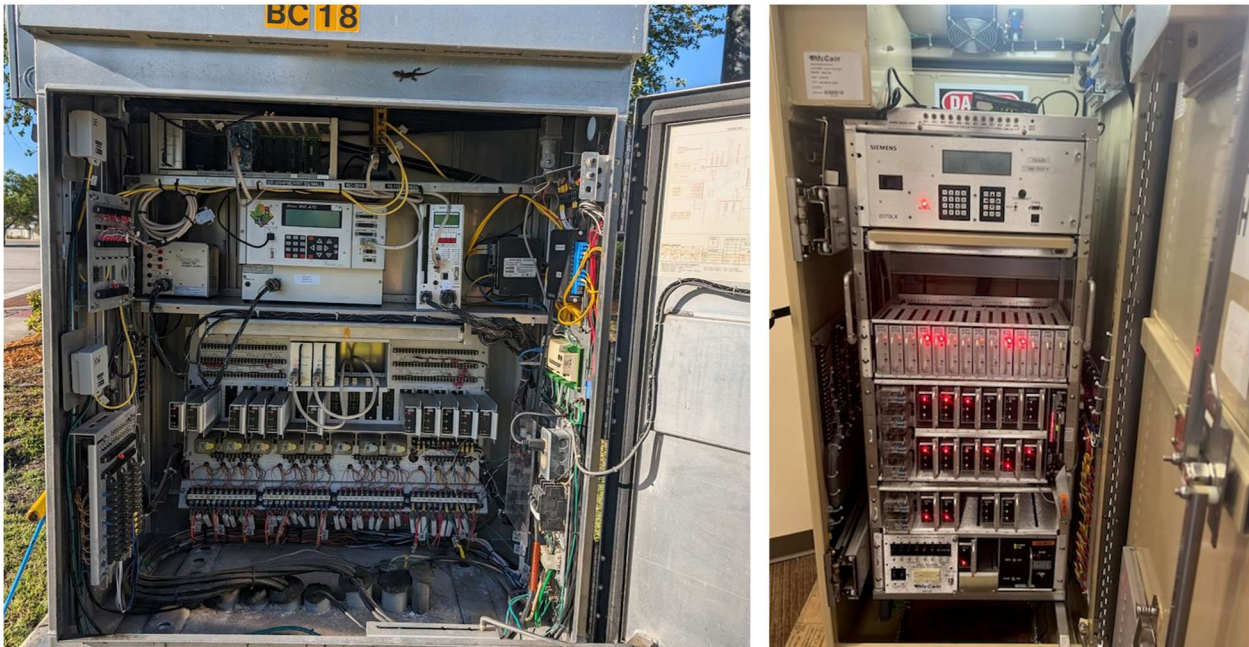

Figure 3-15: Examples of signal controller cabinet assembly interiors

Table 3-7: Field Review Questionnaire – Intelligent Transportation System Cabinet Assembly

(1)	Verify if the existing site includes an existing Intelligent Transportation Systems (ITS) cabinet assembly.	<input type="checkbox"/> Yes	<input type="checkbox"/> No
(2)	If (1) is “Yes”, identify the cabinet assembly standard or size.	<input type="checkbox"/> Type 332/334 <input type="checkbox"/> Type 332D <input type="checkbox"/> Type 336 <input type="checkbox"/> Type 336S <input type="checkbox"/> Type P44 <input type="checkbox"/> Other (NEMA 3R)	
(2a)	If (2) is “Other”, identify the dimensions of the NEMA 3R enclosure	_____ inches (H) _____ inches (W) _____ inches (D)	
(2b)	Identify the installation method for the cabinet assembly.	<input type="checkbox"/> Base Mounted <input type="checkbox"/> Structure Mounted	
(3)		Device Type: _____	

	<p>Identify the field devices supported by the site. For each field device identify manufacturer and model.</p> <p>CCTV Camera Microwave Vehicle Detection System (MVDS) Dynamic Message Sign (DMS) Roadway Weather Information System (RWIS) Bluetooth Travel Time Reader Connected Vehicle Roadside Unit (RSU) Wrong-Way Vehicle Detection System (WWVDS)</p>	Manufacturer: _____ Model: _____ Device Type: _____ Manufacturer: _____ Model: _____ Device Type: _____ Manufacturer: _____ Model: _____ Device Type: _____ Manufacturer: _____ Model: _____
(4)	Identify the available power source(s) within the cabinet assembly.	<input type="checkbox"/> Power Strip (standard) <input type="checkbox"/> RPMU (network-enabled) <input type="checkbox"/> Outlet Box <input type="checkbox"/> GFCI
(4a)	Identify the number of total and available power outlets within the cabinet assembly.	Total: _____ Available: _____
(4b)	If (4) is "RPMU (network-enabled)", identify the manufacturer and model of the remote power management unit (RPMU).	Manufacturer: _____ Model: _____
(5)	Identify if the cabinet assembly includes an uninterruptible power supply (UPS) and battery backup.	<input type="checkbox"/> Yes <input type="checkbox"/> No
(5a)	If (5) is "Yes", identify the manufacturer and model of the UPS, as well as the installation date of the batteries.	Manufacturer: _____ Model: _____ Date: _____
(6)	Identify if the existing cabinet includes available physical space for additional in-cabinet components.	<input type="checkbox"/> Yes <input type="checkbox"/> No
(6a)	If (6) is "Yes", identify the method of installation for new in-cabinet equipment.	<input type="checkbox"/> DIN Rail <input type="checkbox"/> Shelf-Mounted
(7)	Identify the total number of conduit sweeps into the cabinet foundation.	
(7a)	Identify the number of spare conduits, as well as the utilization of each conduit (e.g., low-voltage, fiber optic, electrical service).	No. _____ (low-voltage) No. _____ (fiber optics) No. _____ (electrical)
(7b)	Identify the number of conduits with available capacity, as well as the utilization of each conduit (e.g., low-voltage, fiber optic, electrical service).	No. _____ (low-voltage) No. _____ (fiber optics)

No. _____ (electrical)



Figure 3-16: Examples of Intelligent Transportation Systems cabinet assembly interiors

3.1.2.5 Associated Infrastructure

The Engineer will be responsible for determining the location and condition of the associated aboveground and underground infrastructure to convey power and communications cabling between field devices and the cabinet assembly. Within a site this includes, but is not limited to, conduit pathways, pull boxes, splice boxes, junction boxes, risers, weatherheads, and other permanent infrastructure.

Table 3-8: Field Review Questionnaire – Associated Infrastructure

(1)	Identify if there is an existing conduit pathway(s) between the cabinet assembly and endpoints (e.g., structure).	<input type="checkbox"/> Yes	<input type="checkbox"/> No
(1a)	If (1) is “Yes”, identify the nominal diameter size for the conduit pathway.	<input type="checkbox"/> 1-inch <input type="checkbox"/> 1.5-inch <input type="checkbox"/> 2-inch <input type="checkbox"/> 3-inch	
(1b)	If (1) is “Yes”, identify the total number of conduits in the run.		
(1c)	Identify the number of spare (empty) conduits in the run.		
(1d)	Identify the number of conduits with available capacity in the run.		
(1e)	Identify the utilization of conduit(s) in the run (e.g., low-voltage signal, high-voltage signal, fiber optics, electrical service).	(1) _____ (2) _____ (3) _____ (4) _____	
(2)	Identify condition of underground pull boxes within the conduit run for the feasibility of installing new cabling.	<input type="checkbox"/> Good (useable) <input type="checkbox"/> Fair (questionable) <input type="checkbox"/> Poor (unusable)	

(3)	Identify if the conduit run includes aboveground conduit with risers.	<input type="checkbox"/> Yes	<input type="checkbox"/> No
(3a)	If (3) is “Yes”, identify the total number and available cabling ports within the weatherhead.	Total: _____ Available: _____	

3.1.3 Stakeholder Coordination

3.1.3.1 Local Agency Coordination

A critical component for the success of a CV project is through coordination with the pertinent local agencies as project stakeholders. This coordination should begin in the earliest stages of project development and is encouraged to be maintained through the lifecycle providing updates to stakeholders and continuing to solicit feedback from the involved parties. When hosting discussions with local stakeholders ensure the “right” people are involved in the conversation with the appropriate technical background and ability to make key decisions on behalf of the organization. The correct individuals to be involved in these discussions will vary for each agency based on size, complexity, and organizational structure. Below are some examples of positions to include in local agency coordination efforts:

Best Practice: Project Coordination should begin in the earliest stages of project development with all pertinent local agencies and stakeholders.

- Traffic Engineer
- Signal Technician (lead)
- Public Works Director
- Information Technology (IT) – Network Administrator

For each agency, the Engineer and Project Manager will coordinate with involved stakeholders to determine the specific roles on the project. For example, will the organization be responsible for the maintenance, operations, or funding of equipment and infrastructure installed (e.g., local maintaining agency) or is the entity an interested third-party with a vested stake in the success of the project (e.g., MPO/TPO).

The following key items will require Engineer/local agency coordination to ensure successful delivery of the project:

- Overall project scope, objectives, and goals
- Facilitate a technical conversation between agency and District
- Coordinate with the District to foster agency-to-agency knowledge transfer
- Identify roles and responsibilities for maintenance and operations of the proposed system(s)
- Determine if revisions to the existing Traffic Signal Maintenance and Compensation Agreements (TSMCA) are necessary to account for new equipment
- Identify proprietary product requirements from the local agency for synchronization with existing systems (e.g., controllers)
- Determine if there are executed Memorandums of Understanding (MOU) between FDOT and the local maintaining agency
- Memorandums of Understanding – network connections, firewall rules for outbound and inbound communications, installation and maintenance responsibilities for on-board units, and data sharing. See Section 2 for more information.
- Obtaining as-built and/or operational information (e.g., signal timing plan, phasing)

- Coordination with the local maintaining agency for keyed access for inside of cabinets
- Share information and conduct public outreach for better understanding of the proposed technologies, systems, and potential benefits to the traveling public

3.1.3.2 Network Design Coordination

The Engineer will be responsible for conducting all necessary coordination for the analysis and design of the network to facilitate a reliable and robust high-speed data exchange between various systems and components of the CV deployment. For more information related to the network design and coordination refer to **Appendix A1**.

3.1.4 Technology

CV deployments often include novel technologies or devices necessary to collect real-time information on traffic signal status, vehicle position/movement, roadway conditions, and vulnerable road user position/movement to enable complex applications such as near-miss detection and warning as well as others. FDOT requires that equipment used as part of traffic control systems be vetted and demonstrated in a safe environment prior to use on public roads.

The FDOT Traffic Engineering Research Laboratory (TERL) is responsible for reviewing and approving electronic traffic control devices for statewide use based on product evaluations to verify compliance with FDOT specifications. Devices that are evaluated and approved by the TERL are listed on the FDOT Approved Product List (APL).

In addition, the TERL works with local agencies and FDOT Districts to issue Traffic Control Device Permits that authorize the use of new technology and devices that are not already defined by FDOT specifications. TERL has authority to permit official traffic control signals and devices, and ancillary devices proposed for installation and limited use on streets and highways in the state for new technologies and products that show good cause for safety and mobility.

To obtain the proper approvals, verify the feasibility of implementing new technologies, and to ensure each system performs safely and as intended, coordination with the TERL is required. The Engineer of Record (EOR) must ensure all necessary coordination efforts for product reviews and approvals occur, including coordination between the local agency, District, and Central Office with respect to traffic control signals and devices (and ancillary devices) that are proposed for use as part of a traffic control system but are not listed on the APL.

3.1.4.1 Traffic Control Device Permits

If a project requires approval for a new system, device, or equipment, the Engineer will need to work with the District to complete and submit a “Request for Traffic Control Device Permit.” Submitted to Central Office by the District Traffic Operations Engineer (DTOE), the completed form will need to provide generalized information about the project, as well as specific product information and the justification for its specific need. Each form will include the following:

- **Sponsorship and Concurrence** – identifies the Department sponsor for the requested traffic control device
- **Product Information** – determines the exact model(s) of the proposed hardware and intended purpose
- **Applicant Information** – provides general contact information for the manufacturer of the product
- **Project Information** – identifies the information for the project including financial project identification number (FPID), project name, and location
- **Justification** – identifies the specific needs and benefits for the product and why this particular device was selected for evaluation

FDOT
Florida Department of Transportation
Traffic Engineering and Operations Office
Traffic Engineering Research Laboratory
Request for Traffic Control Device Permit

As allowed by Florida Statute 316.0745 (8), this completed form and attached information submitted by the FDOT District Traffic Operations Engineer (or designee) serves to concur with the request that the product and number of units described herein be considered for a Traffic Control Device Permit on the project indicated below.

I. SPONSORSHIP AND CONCURRENCE
Maintaining Agency: _____ Contact Person: _____
FDOT District: _____ FDOT District Traffic Operations Engineer: _____

II. PRODUCT INFORMATION
Product Name: _____ Model: _____
Proposed Use: _____

III. APPLICANT INFORMATION
Vendor Name: _____ Website: _____
Contact Person/Title: _____ E-mail: _____
Address: _____ Phone: _____
City: _____ State/Province: _____
Zip: _____ Country: _____

IV. PROJECT INFORMATION
Project Number: _____ City/County: _____
Number of Units Proposed for Installation: _____
Intersections/Roads and/or Mile Posts for Installation: _____

V. JUSTIFICATION
Benefits to state of Florida (e.g., safety, efficiency, cost): _____
Are there similar products on the APL? _____ If yes, indicate product features and benefits currently not available from APL listed products. _____
Is there an FDOT product specification for the product type? _____ If yes, indicate requirements needed but not listed in current product specification. _____

FDOT Traffic Engineering and Operations Office
Traffic Engineering Research Laboratory
Page 1 of 2
Form TPE-71-04-1 (Effective 1/13/2020)
(This is an uncontrolled document. Contact FDOT for latest version.)

Figure 3-17: Example Request for Traffic Control Device Permit

3.2 Final Engineering and Design Considerations

Following completion of all Preliminary Engineering activities, the Engineer will be responsible for finalizing the technical design and development of Release for Construction (RFC) documents – including plans and specifications. This phase will build upon previous efforts with an emphasis on defining the equipment, infrastructure, and hardware necessary for a fully functional installation with sufficient detail for construction.

3.2.1 Design Considerations

The following sections will provide best practice recommendations related to the design of CV equipment and infrastructure – including RSUs, edge computing devices, in-cabinet equipment, ancillary infrastructure (e.g., conduits, pull boxes, cabling), structures and mounting hardware, and network parameters.

3.2.1.1 Roadside Units

The placement of RSUs is critical to ensure the unit is capable of receiving and transmitting messages between vehicles and roadside infrastructure. Proper placement will maximize the area of coverage and minimize interference to communications resulting from environmental factors. The Engineer will be responsible for selecting device locations to provide the necessary area of coverage as well as ensuring that plans and specifications sufficiently detail proper grounding, proper distances from power source(s), and allow for future maintenance activities.

RSUs utilize omni-directional antennas to transmit and receive messages enabling a 360-degree communications radius that can extend up to one mile in ideal conditions. The exact signal strength and achieved radius is dependent on horizontal and vertical curvature of the roadway, physical obstructions (e.g., sign structures, buildings, bridges, vegetation), and signal interference from adjacent sources. Typical RSU installations include a ¼-mile to ½-mile radius centered about the device.

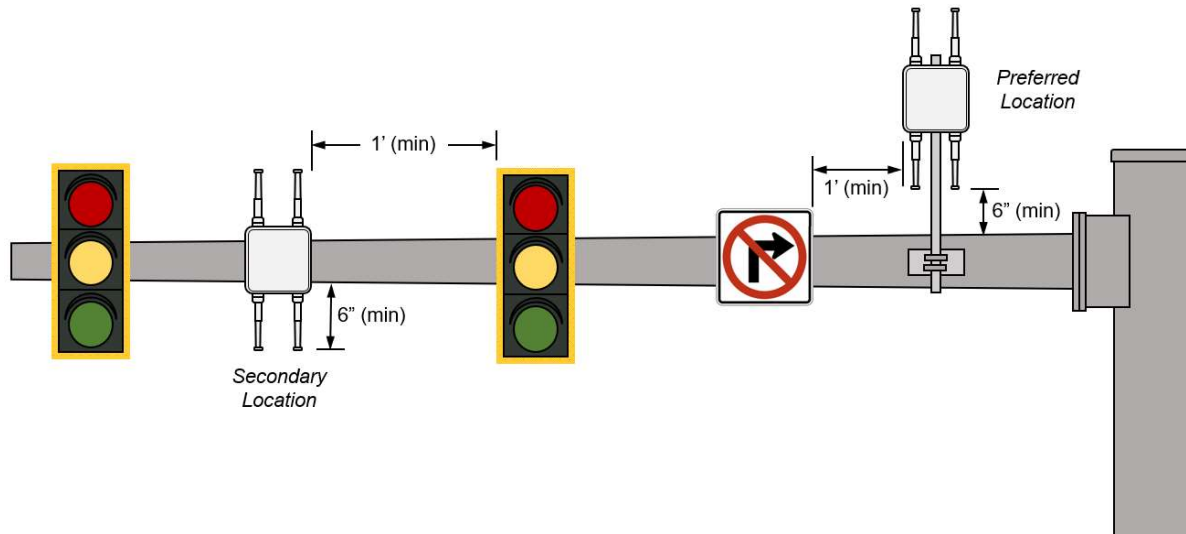

Figure 3-18: Typical mast arm installation showing recommended horizontal and vertical clearance of antennas to avoid occlusion and signal interference

For signalized intersections when installing an RSU on mast arm structures, consider the following recommendations:

- Provide minimum one-foot (1') horizontal clearance between RSU and structural elements and adjacent attachments (e.g., signal heads, overhead sign panels) installed on a mast arm. Recommend measuring from the outside edge of the attachment and the centerline of the nearest antenna. Best practice includes installing RSU between the gusset plate of the upright support and the first attachment, where feasible. For projects installing new mast arm structures, the additional design loads of the unit can be accounted for within the structural analysis providing flexibility in the proposed mounting locations.
- Provide a minimum six inches (6") of clear, unimpeded space for all antennas. Ensure units are installed such that antennas are positioned above or below the mast arm to avoid signal interference. Install vertical risers to provide sufficient height above the mast arm for locations, as necessary.
- Install units at a minimum height of eighteen feet (18') above grade, where feasible. RSUs should be placed so that the center line of 5.9 GHz antennas is at a height between 20-26 feet whenever possible. Mounting heights at or below 26 feet (26') typically allow RSUs to operate at full power and still comply with FCC rules regarding maximum equivalent isotropic radiated power (EIRP). If antennas are mounted above 26 feet (26'), then the RSU output power must be reduced to comply with Federal Communications Commission (FCC) rules regarding maximum EIRP.
- Identify the structure capable of providing the greatest coverage of the intersection with unobstructed line of sight to all legs of both the major and minor roadways. Where feasible, install units on the mast arm structure located within the same intersection corner as the controller

cabinet. If the corner with the controller cabinet is empty, select the corner with a mast arm structure closest to cabinet to minimize cabling length.

- Ensure total cabling length between the RSU unit and the controller cabinet is no greater than 300 feet to support power-over Ethernet (*IEEE 802.3af, at, bt*), otherwise, alternative communication, cabling, or power accommodations will likely be required. Aggregate total must include horizontal and vertical cabling length, as well as slack within pull boxes, cabinets, and drip loops.
- Identify whether or not the mast arm structure includes an easy-to-access cabling egress point from which to pull the necessary cabling from the interior of the upright to the device. The intent is to install device cabling without the need to drill additional exit holes within the structure. Typical cabling egress locations include the open space between the mast arm and gusset plate of the upright.
- For locations where mast arm structures do not include cabling egress points, consult with a licensed structural engineer to determine the feasibility of installing a new drilled hole without degrading structural integrity. Coordinate with the Department for approval. The maximum recommended diameter for new drilled holes is one inch (1"). Outfit each drilled hole with a watertight cabling grommet.
- Select installation locations for units that can be maintained without lane closures (e.g., over shoulder and sidewalk), where feasible.

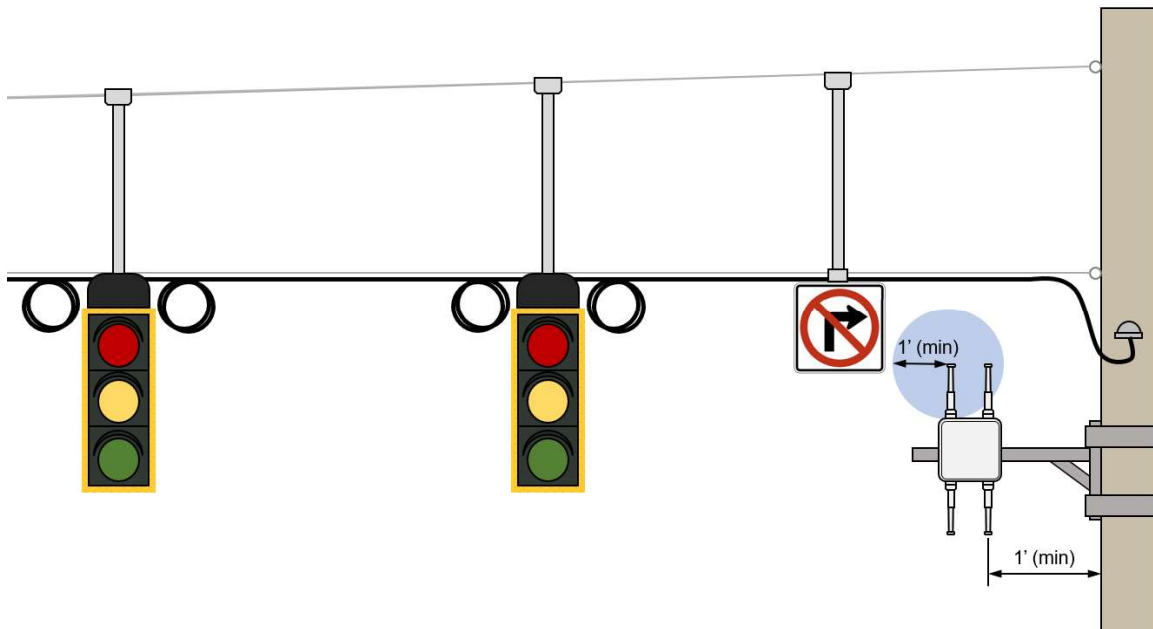

Figure 3-19: Typical strain pole installation with recommended horizontal clearance of antennas

For signalized intersections when installing an RSU on strain pole structures, consider the following recommendations:

- Install units on horizontal cantilever arms to provide a minimum of one foot (1') horizontal clearance from the face of the strain pole. Position units to provide a minimum of one foot (1') radial clearance from adjacent attachments (e.g., signal heads, overhead sign panels) to each antenna to minimize signal interference.
- Orient the cantilever arms to the center of the signalized intersection.

- Install units at a minimum height of eighteen feet (18') above grade. RSUs should be placed so that the center line of 5.9GHz antennas is at a height between 20-26 feet whenever possible. Mounting heights at or below 26 feet (26') typically allow RSUs to operate at full power and still comply with FCC rules regarding maximum equivalent isotropic radiated power (EIRP). If antennas are mounted above 26 feet (26'), then the RSU output power must be reduced to comply with Federal Communications Commission (FCC) rules regarding maximum EIRP.
- Identify the structure capable of providing the greatest coverage of the intersection with unobstructed line of sight to all legs of both the major and minor roadways if possible. Where feasible, install units on the strain pole located within the same intersection corner as the controller cabinet. If the corner with the controller cabinet is empty, select the corner with a strain pole structure closest to cabinet to minimize cabling length.
- Ensure total cabling length between the unit and the controller cabinet is no greater than 300 feet (300') to support power-over Ethernet (*IEEE 802.3af, at, bt*). Aggregate total must include horizontal and vertical cabling length, as well as slack within pull boxes, cabinets, and drip loops.
- Verify the selected strain pole includes either an embedded weatherhead or vertical conduit risers to accommodate cabling pathway to the device. Where applicable, confirm the weatherhead includes sufficient capacity for additional cable entry.
- For locations that do not have capacity to support additional cabling, install vertical conduit risers to the strain pole. Ensure all aboveground conduits are rigid galvanized steel and provided a weatherhead for cabling egress. Conduit risers should be secured to the strain pole using either conduit straps or banding installed at five-foot (5') intervals, center-to-center. Ensure banding does not impede the function of existing signing or signalization equipment installed on the pole.
- For locations in which the cabinet and proposed device location are not collocated on the same corner, secure device cabling to the existing messenger wire across the roadway from strain pole to strain pole. Ensure the cabling is lashed or secured by alternative means to the messenger wire.
- Select installation locations for units that can be maintained without lane closures (e.g., over shoulder or sidewalk), where feasible.

For the installation of RSU on limited-access corridors, consider the following:

- The preference is to install units on dedicated ITS device poles collocated with other roadside devices – including CCTV cameras, microwave vehicle detection systems (MVDS), and more. Where poles are not available, units may be installed on DMS structures or new ITS device poles.
- At locations leveraging poles or structures installed outside of the roadway and shoulder, position units such that the face of the RSU is parallel to the direction of travel. This will result in an omni-directional sphere of transmission capable of communicating with vehicles traveling in both directions and no negatively impacting occlusion to the antennas from the structure.
- At locations leveraging poles or structures installed in the median, position units such that the face of the RSU is parallel to the direction of travel. This will result in an omni-directional sphere of transmission capable of communicating with vehicles traveling in both directions with only a minor occlusion to the antennas from the structure positioned immediately behind the device.

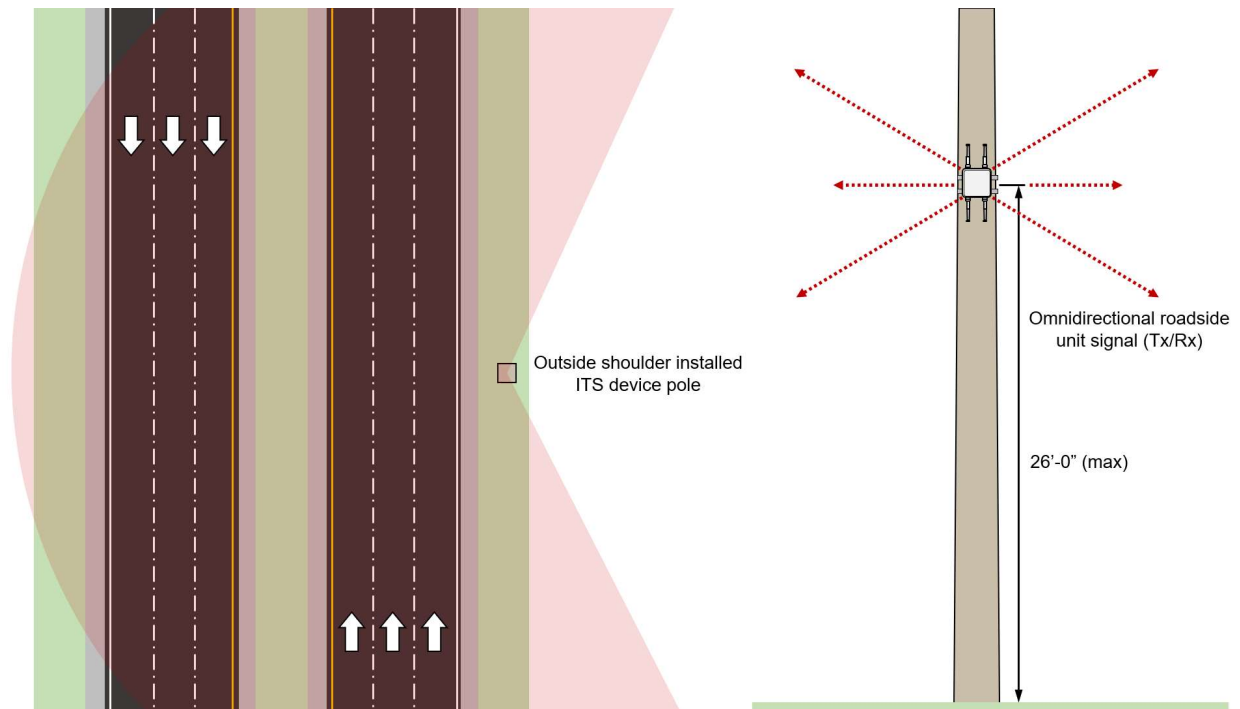

Figure 3-20: Typical roadside unit deployment on structure location on outside shoulder of limited-access corridor

- Install units at a minimum height of eighteen feet (18') above grade. RSUs should be placed so that the center line of 5.9GHz antennas is at a height between 20-26 feet whenever possible. Mounting heights at or below 26 feet (26') typically allow RSUs to operate at full power and still comply with FCC rules regarding maximum equivalent isotropic radiated power (EIRP). If antennas are mounted above 26 feet (26'), then the RSU output power must be reduced to comply with FCC rules regarding maximum EIRP. At locations where greater heights are required, the Engineer will need to coordinate with the Department to identify options – including possible enforcement of project-specific requirements for reduced power emission.

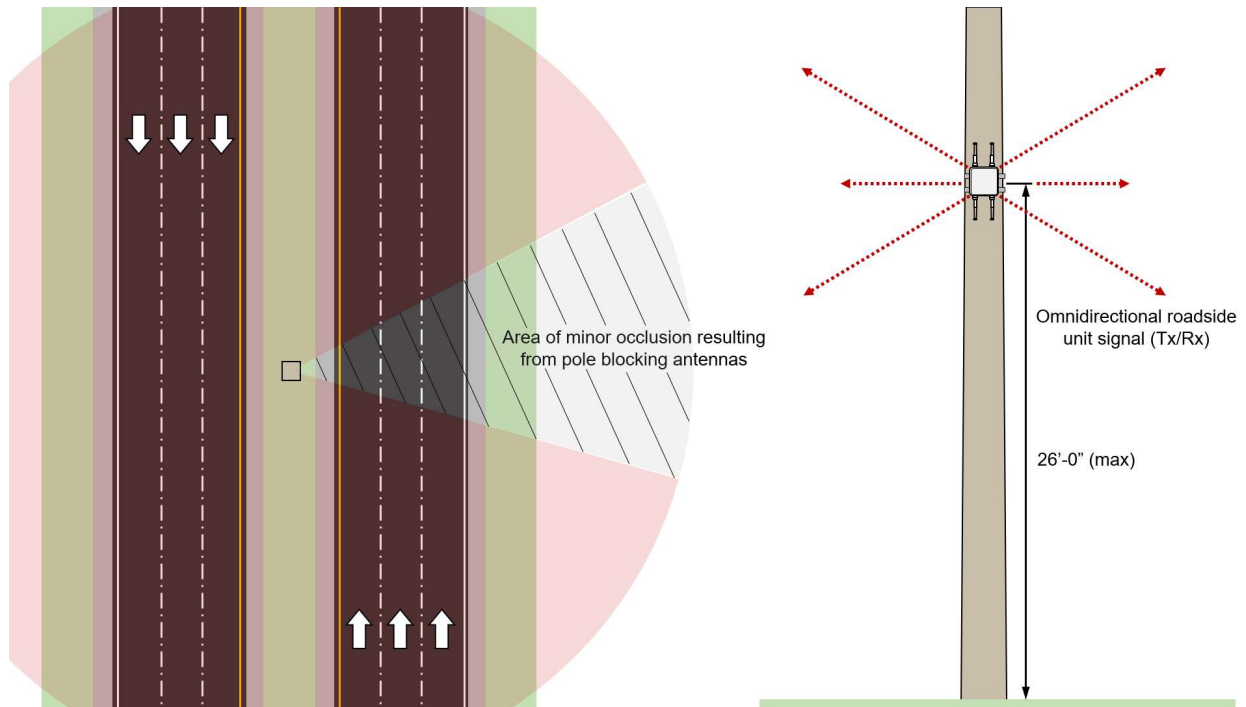

Figure 3-21: Typical roadside unit deployment of structure location installed in the median of a limited-access corridor

- Verify the proposed device location does not negatively impact the functionality of other devices. Ensure the unit is installed in a manner that does not foul up the process for camera lowering devices.
- Ensure total cabling length between the unit and the cabinet is no greater than 300 feet (300') to support power-over Ethernet (*IEEE 802.3af, at, bt*). Aggregate total must include horizontal and vertical cabling length, as well as slack within pull boxes, cabinets, and drip loops.
- Verify the selected device pole includes either an embedded weatherhead or vertical conduit risers to accommodate cabling pathway to the device. Where applicable, confirm the weatherhead includes sufficient capacity for additional cable entry.
- For locations that do not have capacity to support additional cabling, install vertical conduit risers to the device pole. Ensure all aboveground conduits are rigid galvanized steel and provided a weatherhead for cabling egress. Conduit risers should be secured to the device pole using either conduit straps or banding installed at five-foot intervals, center-to-center. Ensure banding does not impede the function of existing devices or pole-mounted cabinets installed on the structure.
- Select installation locations for units that can be maintained without lane closures (e.g., over shoulder or flat grassy area), where feasible.

3.2.1.2 Edge Computing Devices

Edge computing devices are hardened roadside equipment providing the processing power necessary to enable complex business logic for CV applications. Industrial computers for CV applications are sometimes included as edge computing devices within a project to provide specific benefits and functionality – including reduced network latency, increased scalability, enhanced security, and more. However, there is usually a significant cost increase on a per site basis for the inclusion of edge computing equipment. The decision to include edge computing devices within the proposed CV system must be closely coordinated with the project owner (e.g., FDOT TSM&O group, local maintaining agency, or other partners). The EOR

will be responsible for understanding the specific needs of the proposed system and determining the pros and cons, as well as the anticipated cost, to help the Department make informed decisions regarding the optimal hardware architecture.

Within some CV deployments, the edge computing device must serve as a specialty computing device and execute software that is responsible for handling various data inputs from the system(s), analyzing the available data, applying preconfigured business rules/logic to that data, and enacting appropriate responses based on configured rules and logic.

EXAMPLE: The Department intends to implement a *Pedestrian in Signalized Crosswalk Warning* application at a mid-block crossing. The system will include a roadside unit, passive pedestrian detection equipment, and an edge computing device as part of the mid-block crossing signal system. As pedestrians enter and exit the crossing, the passive pedestrian detection system will capture the presence, location, and movements of pedestrians. The detection data will be analyzed using internal software and business logic on an edge computing device to develop SAE J2735 compliant messages that communicate the position, speed, and heading of detected pedestrians. The RSU will receive ready-to-broadcast messages from the edge computing device. Motorists will receive audible and/or visual warnings to notify drivers of pedestrians in the crosswalk ahead, ultimately increasing driver awareness and improving safety for the mid-block crossing.

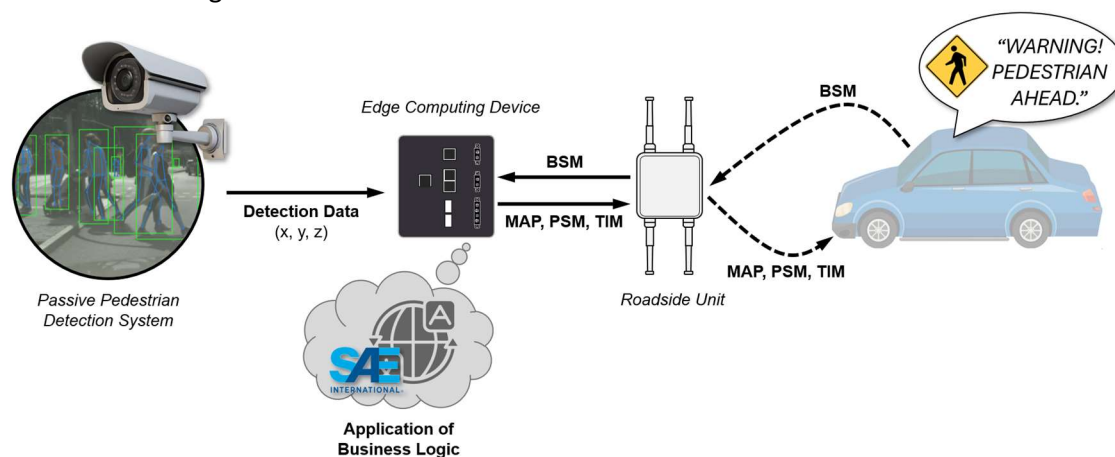

The specific functionality of individual components within an architecture with or without edge computing devices may vary. As an example, systems relying on edge computing devices to generate and transmit messages may only require the roadside unit to function as a simple wireless communication radio – defaulting all intelligence to the edge computing device. Conversely, architectures without edge computing devices may rely on the roadside unit to perform many of these functions to generate messages and execute various applications.

Where edge computing devices are to be installed as part of the system, the EOR will be responsible for ensuring the location provides the necessary power and communications to operate the device. Typical installations require a single Cat-6 Ethernet connection to the network device and a standard 120VAC outlet to receive power. Ensure the proposed cabinet provides sufficient space to accommodate the physical dimensions of the unit, as edge computing devices are available in a variety of shapes and sizes. When identifying the proposed location within the cabinet, ensure there is sufficient open space around the unit to allow for circulation from the cooling fan. Edge computing devices can create significant heat

when processing large quantities of data, so keeping the unit cool will ensure optimal performance and maximize the life of the hardware.

3.2.1.3 Network Connectivity

Connected Vehicle RSE requires a network connection and Internet access to function properly. For example, an RSU must regularly use the Internet to receive security certificate top-offs from FDOT’s statewide SCMS. CV deployments must include network communications that provide data connectivity between equipment in the field, other devices/systems on the transportation agency communication network (usually both the local maintaining agency and District ITS network), and secure access to the internet. Multiple technologies can be used to establish network communications—including fiber optic cabling, point-to-point wireless radios, and cellular modems—each providing a unique set of benefits and limitations.

Fiber Optics	
<i>Pros</i>	<i>Cons</i>
<ul style="list-style-type: none"> • Low cost for maintenance; no recurring licensing or monthly subscription costs • High reliability and quality of connection • Greater bandwidth and capacity for network traffic • Capable of long-distance connections • Enhanced security • Resistant to interference, noise • Scalable to handle future growth 	<ul style="list-style-type: none"> • Higher capital costs for initial installation • Higher likelihood for physical damage (e.g., damage from excavation, unintended cable breaks) • Requires skilled technicians for fiber optic connection installation (e.g., splicing, terminations)
Point-to-Point Wireless Radios	
<i>Pros</i>	<i>Cons</i>
<ul style="list-style-type: none"> • Low costs for initial deployment, less infrastructure • Average cost for maintenance; no recurring licensing or monthly subscription costs • Requires limited to no underground infrastructure, less susceptible to damage from excavation • Flexible network architecture options (e.g., P2P, P2MP; licensed vs. unlicensed) • Ability to traverse long distances, difficult terrain (e.g., bodies of water) 	<ul style="list-style-type: none"> • Limited reliability, variable quality of connection • Limited bandwidth and capacity for network traffic • Higher security risk • Susceptible to environmental degradation (e.g., interference, noise) • Requires clear line of sight between radios (e.g., vegetation, tall structures) • Requires skill technicians for configuration, troubleshooting, and maintenance

Cellular Modem	
Pros	Cons
<ul style="list-style-type: none"> • Low costs for initial deployment, less infrastructure • Low costs for maintenance activities • Requires no underground infrastructure, less susceptible to damage from excavation • No specialized skillset necessary for maintenance 	<ul style="list-style-type: none"> • Requires monthly subscription cost • Quality of connection, reliability based on third-party cellular provider's network strength • Limited bandwidth and capacity for network traffic • Higher security risk

Coordination with transportation agency managers and network administrators is necessary during design to determine the most appropriate means of communication for CV equipment locations based on Department needs, local maintaining agency preferences, existing conditions, and pertinent project constraints.

The EOR is responsible for determining the appropriate means of communication for each signalized intersection based on coordination with the Department, local maintaining agency preferences, existing conditions, and pertinent project constraints.

Designs must ensure that there is a managed field Ethernet switch (MFES) installed with sufficient port capacity installed at each CV equipment location. The switch must accommodate any existing equipment as well as new CV equipment connections such as RSU, edge computing device, and remote power management unit (RPMU) connections. Best practice is for the MFES port count to provide spare capacity and at least one open port available for local technician access. The EOR must coordinate with local maintaining agencies as needed to identify specific technical requirements of the switch and determine if there are proprietary products necessary for synchronization with existing systems and equipment. Ensure each switch provides the minimum number of copper Ethernet ports (RJ-45) and small-form pluggable (SFP) fiber optic ports necessary to accommodate the field devices and network connections proposed with a minimum of two spare copper ports (RJ-45) for future use. Designers and Construction Contractors must also coordinate with the local maintaining agency to identify if any specific, preferred port use schema exists (e.g., Port No. 1 remains open for maintenance).. Based on the specific needs of the project, the EOR may be required to include pay item notes with specifics information related to the MFES per local maintaining agency preferences.

3.2.1.4 In-Cabinet Equipment

The installation of infrastructure, devices, and equipment to enable CV applications includes roadside units and the requisite in-cabinet equipment to deploy a fully functional system. The following in-cabinet devices should be considered **standard** for all deployments notwithstanding special circumstances.

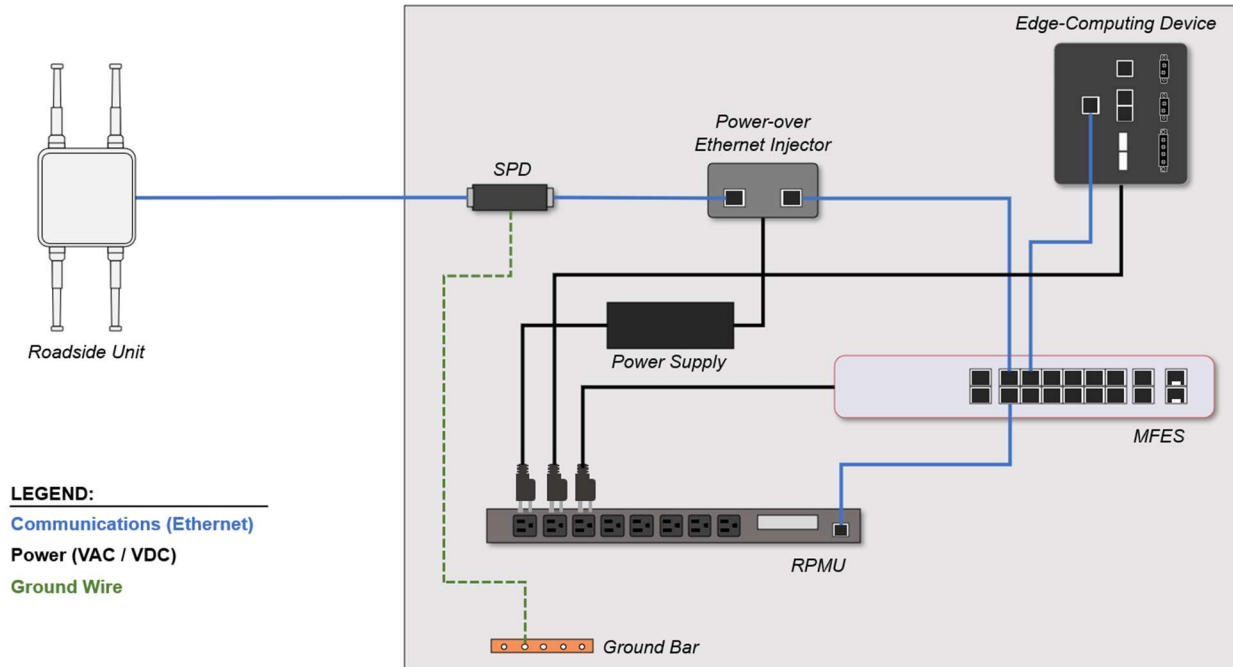

Figure 3-22: Example Connected Vehicle architecture for typical ITS deployment

- Surge Protection Devices (SPD)** are required to protect valuable electronic equipment within the cabinet from dangerous voltages resulting from lightning or other unexpected causes. Each RSU is required to include an in-line SPD installed between the above-ground device and other equipment within the cabinet. Typical designs include an SPD installed along the Category 6 (Cat-6) Ethernet cable between the cabinet and device. No conductive line connecting to equipment within the cabinet should be unprotected. Ensure all SPDs include a ground wire connection to the ground bar within the cabinet. While available in all shapes and sizes, the common method of installing SPDs is using a standard DIN rail.
- Power-Over Ethernet (POE) Injector** are unified devices supplying power and communications over a single Ethernet cable (Cat-6) allowing simultaneous data transfer and electrification with less equipment and infrastructure. POE technologies are available in three distinct standards:

Common Name	Standard	Max. Power per Port
POE	IEEE 802.3af	15.4 W
POE+	IEEE 802.at	30 W
POE++	IEEE 802.bt	60 W (Type 3) 100 W (Type 4)

The EOR will be responsible for identifying the necessary wattage required by the RSU and selecting the appropriate technology standard and equipment to power the system. A power supply unit with the requisite output voltage and connection to the remote power management unit should be provided. Ensure each POE injector is connected to the network switch to enable network communication using an Ethernet patch cable (Cat-6). Consider providing devices that are enabled with Simple Network Management Protocol (SNMP) capabilities to allow for monitoring of the real-time status to determine device failures remotely. Coordinate with the District to determine the specific preferences and

requirements of the system. POE injectors and associated power supplies are available in either shelf-mounted or DIN rail mounted form factors.

- **Remote Power Management Units (RPMU)** are hardened, programmable outlet strips that enable the power and control of devices and in-cabinet remotely. Each RPMU is connected to the network switch via an Ethernet patch cable (Cat-6) providing a real-time link between the device and the central command center – such as the Regional Traffic Management Center. Remote users will be able to quickly troubleshoot failed devices and in-cabinet equipment by cycling power on and off to individual outlets within the unit without having to be on-site costing both time and money. The RPMU will be connected to the available shore power within the cabinet through a standard 120VAC outlet. Where available, it is recommended to connect the RPMU into a power source providing battery backup. RPMUs are available in different sizes with the total number of available outlets varying and while typically rack-mounted within the cabinet, the ability to install on a shelf is an option where necessary.
- **Managed Field Ethernet Switches (MFES)** connect roadside devices and equipment with the appropriate network for either the District or local maintaining agency enabling data exchange. Many agencies maintain specific requirements or preferences for switches ranging from manufacture and model number, total port count, technology standards, routing capabilities, and more. The EOR will be responsible for determining the appropriate MFES requirements to satisfy the project needs and maintaining agency preferences. Ensure the proposed switch provides the minimum number of copper Ethernet ports (RJ-45) to accommodate connections to all devices and in-cabinet equipment with a minimum of one spare port to remain empty, reserved for future use. Coordinate with the maintaining agency to determine if there is a standard port assignment for devices and in-cabinet equipment, or if there are ongoing or future efforts that may impact the total number of available ports or arrangement of port assignments. Ensure each MFES is connected to field devices and in-cabinet equipment using Cat-6 Ethernet cabling and receiving power from the RPMU. Verify if the MFES will require a power supply unit to provide the appropriate operating voltage. Switches are available in a variety of sizes and shapes and can be installed either on a standard DIN rail, shelf-mounted, or rack-mounted.

Supplementing the standard in-cabinet equipment, some CV deployments may require additional components to meet specific project needs or preferred architecture, including:

- **Edge Computing Devices** should be considered on a project-by-project basis dependent upon the specific applications or architecture of the system. These hardened computational units will require a Cat-6 Ethernet patch cable linking to the MFES and connection to the RPMU for power. Determine if the edge computing device will require a power supply unit to provide the appropriate operating voltage. The form factor of these devices is variable and can be either installed using a standard DIN rail or shelf-mounted procedures. If the edge computing device is responsible for ingesting data or driving output commands to external systems, ensure the proper connections are established to enable data exchange, as necessary. Refer to **Section 3.2.1.2** for additional information.
- **Power-Over Ethernet (POE) Extenders** may be required for locations in which the proposed RSU location exceeds the allowable maximum Ethernet cabling distance. Extenders are in-line, hardened devices that regenerate POE transmission by enhancing the distance capabilities beyond the 328-foot limit. Compatible with either Cat-5e or Cat-6 Ethernet cabling, POE extenders can typically double the maximum distance between the cabinet and the RSU for atypical installations – such as large intersections or remote cabinet locations. Due to the ruggedized

construction of these devices, extenders can be installed in cabinets, pull boxes, or the interior of poles and structures.

- **Cellular Modems** may be utilized in locations without established communications to facilitate network connectivity between the field devices and the central network, such as remote signalized intersections. Using a Subscriber Identity Module (SIM) card, these devices serve as a router between the field equipment and maintaining agency's network leveraging the internet and existing communications infrastructure maintained by the selected cellular service provider. Modems can be used in conjunction with switches, or at sites with limited need for copper Ethernet ports (RJ-45) can be deployed in lieu of network switches. Modems are available in several options with differing ports quantities, bandwidth, networking speeds, throughput, and technology standard (i.e., 4G, 4G LTE, 5G). Where proposed, the EOR is responsible for determining the appropriate cellular modem to meet the needs of the project. Ensure the proposed deployment site provides sufficient signal strength to facilitate upload and download communications. Determine if an external antenna is required to be located on the outside of the cabinet or on the pole or structure to increase signal strength. Cellular modems will require connection to either the MFES or directly to field devices and in-cabinet equipment using Cat-6 Ethernet patch cables, based on the specific configuration of the site. Provide a connection to the RPMU for powering the device and verify whether a power supply unit is necessary to furnish the appropriate operating voltage.

3.2.1.5 Support Structure Review

Whenever practical, RSUs and related field equipment should be collocated with existing ITS or signalization deployments. It is recommended to utilize existing structures – including ITS device poles, mast arms, strain poles, overhead sign structures for dynamic message signs – to mount roadside units and leverage existing cabinet infrastructure, wherever possible.

Adding additional equipment and infrastructure to existing structures will increase the deadload and surface area for wind load (moment) of the structure. During the design phase, the existing structure should be evaluated to determine if the additional load will result in degradation of the structural integrity resulting in failure and a potentially dangerous situation. A licensed structural engineer should be responsible for the review of the existing structure and analysis of the additional load. The EOR will be responsible for coordination with the District or local maintaining agency to identify if recent maintenance inspections reports or as-built drawings are available, as well as soliciting input from the Structures Design division of the Department, as appropriate.

Best Practice: Utilize the following strategies to minimize the potential structural impact(s) resulting from the installation of CV equipment:

- Install RSU on the upright structure to eliminate the additional moment.
- Minimize the horizontal distance from the upright connection and where the RSU will be installed to lessen the additional moment.
- Install cabling through the interior of structures to eliminate the need for additional conduit risers and reduce additional dead load.

3.2.1.6 Mounting Hardware Options

Within the design process, the EOR will be responsible for determining the appropriate mounting hardware for above-ground equipment to structures. There are a variety of hardware solutions to rigidly affix devices to structures; however, it is important to determine any constraints that specific sites may

encounter. For example, installing an RSU on the upright of a large structural upright (e.g., DMS) will need to account for the circumference of the structure. Similarly, hardware compatible with a small diameter, round pole may not be appropriate for the installation of equipment on a square concrete pole. The EOR will be required to review each structure and proposed devices will be installed upon developing a tailored manner of installation for each unique scenario.

Mounting devices directly to structures using tapped screws is not acceptable. Banding, saddle clamps, or other non-intrusive methods of securing equipment to structures is preferred.

3.2.2 Plans Development

Ensure all CV plans are developed to meet the requirements set forth in the latest version of FDOT Design Manual (FDM), Standard Plans for Road and Bridge Construction, Standard Specifications for Road and Bridge Construction. This section provides general guidance and best practices for the development of plan sheets and details.

3.2.2.1 Key Sheet

Develop Key Sheet in accordance with FDM 910. The Engineer will be responsible for making the determination of whether the project requires the Key Sheet to be developed as a lead or component plan set and adjust accordingly. CV projects do not require specific information or deviations from the standard Intelligent Transportation Systems (ITS) component set key sheet requirements.

3.2.2.2 General Notes

Develop General Notes sheet in accordance with FDM 914. The Engineer will be responsible for ensuring the notes provided are sufficient to cover all aspects of the project and include District specific CV preferences. Avoid repeating information covered within the Standard Specifications or Standard Plans. Additionally, the General Notes sheet should include a pictorial legend defining any atypical symbology utilized within the plan sheets (e.g., RSU) and all necessary pay item notes. Pay item notes are required for proposed work that requires specific direction to the Contractor outside of the direction given within the Standard Plans and Specifications, as well as all adjust/modify pay item numbers.

General Notes are not to be utilized to identify any preferred products and/or approved PPCs – these must be addressed through Modified Special Provisions (MSP).

(ANY SPECIFIC GENERAL NOTES OR PAY ITEM NOTES TO BE INCLUDED)

3.2.2.3 Project Layout

Develop Project Layout sheet in accordance with FDM 942. The Engineer will be responsible for selecting the appropriate common scale (e.g., 1" = 2000') for the Project Layout sheet necessary to depict all project information in a clean, easy-to-read format. At minimum, Project Layout sheets should include the following:

- Begin Project Limit (w/ stationing)
- End Project Limit (w/ stationing)
- North Arrow
- Scale
- County Line (as applicable)

- Street Names for major intersections and interchanges
- Plan Sheet Numbering
- Device Type, ID No., and Location (existing and proposed) (w/ stationing)
- Match Lines (as required)

If the project does not include baseline or centerline stationing, provide the appropriate latitude/longitude information for project limits and device locations.

3.2.2.4 Device Summary Sheet

For each project, the Engineer is recommended to develop a summary table with all pertinent information about the proposed and existing CV devices – including station and offset, latitude/longitude, structure or pole type, device mounting height, and more.

It is recommended that all CV devices are assigned a unique identifier number to clearly denote each proposed installation location and the number of devices. The Engineer is recommended to coordinate with the District and/or local maintaining agency to determine if there is a specific preference for the device identification nomenclature (e.g., SunGuide software naming convention).

3.2.2.5 Plan Sheets

Develop CV Plan Sheets in accordance with FDM Section 942.4. Plan Sheets should be developed at either 1" = 40', 1" = 50', 1" = 100' scale or approved by the Department's Project Manager.

Plan Sheets should include a unique device identification number at each proposed site for all RSUs. Ensure Plan Sheets clearly depict the existing or proposed infrastructure including field devices, structures, cabinets, conduits, pull boxes, splice vaults, and electrical equipment. The Plan Sheets should also include topographical information (e.g., survey, high-definition aerial photography) necessary to properly identify existing conditions and site constraints, such as right-of-way lines, underground and overhead utilities, roadway and drainage infrastructure, landscaping, signalization equipment, sign structures and more. Ensure device mounting locations, cabinet with in-cabinet equipment, and cabling pathways are clearly depicted in the Plan Sheets.

Provide textual callouts with sufficient information for the Contractor to understand the proposed work, including brief descriptions of work (e.g., activity, size, type) and pay item numbers with the associated quantities and units. Ensure all CV devices – including existing and proposed – are properly identified with the corresponding RSU device identification number, as well as stationing and offset from the baseline/centerline. If the project does not include a baseline or centerline, provide latitude and longitude information for each proposed device. Callouts should clearly depict all proposed connection equipment from outside of the cabinet to inside of the cabinet that can be easily understood by the Contractor during bidding. If areas within the plan sheet are heavily congested or require additional clarity, provide an inset with a higher level of detail and an increase scale (e.g., 1" = 10').

3.2.2.6 Mounting Details

Develop Mounting Details to identify the infrastructure necessary for a complete deployment of field devices. Ensure these details clearly identify the location, quantity, material, and hardware necessary for the installation of individual components of a system. Ensure this detail provides the information necessary for the Contractor to assemble the discrete components into a complete system – including

routing of individual conduit runs and sweeps into pull boxes, cabinets, and foundations; fastening of pole mounted enclosures, devices and signs; mounting heights; and more.

Ensure that the mounting height for the RSU is identified within the detail for each unique scenario measured above finished grade. Do not mount RSU at a height greater than 26 feet (26') unless otherwise approved by the Department.

Provide a downward drip loop to prevent water intrusion and ensure future slack for all exposed cabling locations entering and exiting poles or structures. It is recommended to provide drip loops that are a minimum of six inches (6") in diameter.

Clearly identify the material type, size, and quantity of conduit providing cabling pathways between the cabinet and device installed on the pole or structure. For all locations with aboveground conduit mounted on the exterior of poles or structures, ensure conduit material is specified as rigid galvanized steel with transitions to underground conduit made a minimum of six inches (6") below finished grade. Ensure each aboveground conduit is either terminated within a junction box or provided with a weatherhead to facilitate cabling access to the intended device(s).

3.2.2.7 Wiring Diagrams

Develop Wiring Diagrams to clearly depict the physical connection of field devices and in-cabinet equipment necessary to provide network communications and electrification to each system component. The schematic should illustrate power and communications connections between all components with labels for each type of wiring (e.g., 120VAC, 12VDC or 24VDC, Ethernet [Cat-6], RS-422). Ensure the type of port (e.g., RJ-45, Db-9) is clearly identified for each connection to in-cabinet equipment. Ensure surge protection devices and grounding hardware are depicted. Ensure the complete configuration for power and communications is comprehensively defined at the field level for each system comprised of multiple discrete components. Unique wiring diagrams are not required for each cabinet of the same architecture and configuration. Within the project if multiple cabinets are arranged similarly, typical diagrams may be developed. Ensure each typical diagram includes specific cross-reference notations to the specific project locations, as appropriate.

3.2.2.8 Network Diagrams and Details

Develop Logical Network Diagrams and details that illustrate end-to-end communications schema for all CV devices within the project limits. Clearly identify the appropriate network equipment required for the system to transmit and receive data between the field devices and central network – including hard line or wireless communication methodologies. Ensure that each network equipment device type – network switch (Layer 2), router (Layer 3), cellular modem – is clearly labeled and shown with all attached devices. Determine existing or proposed firewall(s) governing outbound and inbound communications and the owner of each. For fiber optic networks, clearly denote all fiber optic rings and the associated network nodes for each ring. Ensure the target end user(s) destination is identified with communications pathways to enable continuous, uninterrupted data stream – such as the Traffic Management Center.

3.2.3 Specifications

The Department released an updated version of the Connected Vehicle Developmental Specification. The Engineer is responsible for coordination with the District Specifications Office to verify the published version includes the latest language and no additional revisions or updates are pending. The Development

Specification is divided into two sections separating the construction details, measurement, and payment from the physical materials:

- Dev681CVRSE – Connected Vehicle Roadside Equipment
- Dev995CVRSE – Connected Vehicle Roadside Equipment Materials

The Engineer will be responsible for reviewing the Developmental Specification to ensure the content addresses the specific needs of the project. If no changes are required in the Developmental Specification, this document will be incorporated as a Special Provision into the overall Specifications Package. In the event that the Developmental Specifications requires modifications, the EOR will need to create a Technical Special Provision (TSP) for review and approval by the District Specifications Office with concurrence from Central Office.

Dev681CVRSE
Use with Dev995CVRSE

CONNECTED VEHICLE ROADSIDE EQUIPMENT.
(REV 8-30-24)

The following new Section is added:

SECTION 681
CONNECTED VEHICLE ROADSIDE EQUIPMENT

681-1 Description.
Furnish and install Connected Vehicle (CV) Roadside Equipment (RSE) in accordance with the Contract Documents. CV RSE includes the CV Roadside Unit (RSU) and Industrial Computer for CV Applications.

681-2 Materials.
Meet the following requirements:
CV RSU* 995-20.3
Industrial Computer for CV Applications* 995-20.4
*Use products on the Department's Approved Product List (APL).

681-3 Installation.
Install and configure CV equipment and systems, including RSUs, in accordance with the Contract Documents, manufacturer's recommendations, and as directed by the Engineer.
RSUs must be preconfigured by the manufacturer, an authorized manufacturer's representative, or authorized personnel trained by the manufacturer to be ready for installation and operation at the locations shown in the Plans. Each RSU must be preconfigured with communication settings and a MAP file that has been developed for the locations shown in the Plans. Ensure site specific conditions including lane configuration, signal group, phase assignments, allowed maneuvers, and verified location markers are addressed during MAP development and configuration of the RSU prior to installation.
Provide all equipment with the appropriate weatherproof power and communication cables, power supplies, power converters, mounting brackets, and mounting hardware according to the manufacturer's recommendations.
Ensure that equipment is mounted securely and is fully accessible by field technicians. Ensure that status indicators remain unobstructed and visible.

681-3.1 RSU Site Registration: Coordinate RSU site registration with the Department. Provide all information required to register RSU devices and locations with the FCC to the Engineer for review and approval. Support FCC site registration efforts until complete.

681-3.2 Enrollment and Provisioning: Coordinate RSU enrollment and provisioning in the FDOT Security Credential Management System (SCMS) with the Department. Provide the Department with the manufacturer, model, and quantity of RSUs requiring enrollment within sixty (60) of Notice to Proceed (NTP). Ensure each RSU is enrolled and provisioned within the Department's statewide SCMS by the manufacturer per the guidance provided at the following location <https://www.fdot.gov/traffic/teo->

Dev995CVRSE
Use with Dev681CVRSE

CONNECTED VEHICLE ROADSIDE EQUIPMENT.
(REV 8-30-24)

SECTION 995 is expanded by the following new Article:

995-20 Connected Vehicle Roadside Equipment.
995-20.1 General: Meet the applicable national requirements and standards for Connected Vehicle (CV) equipment, including those listed in Table 995-11.

Table 995-11 CV Equipment Requirements and Standards	
Document Identifier	Description
CTI 4001 v01.01 (or later)	Connected Transportation Interoperability (CTI) Roadside Unit (RSU) Standard, Connected intersection-ready Standard of ASHTO, ITE, NEMA, and SAE International (available at www.ite.org).
CTI 4501 v01.00 (or later)	Connected Intersection Implementation Guide (available at www.ite.org).
ISO/TS 19091:2019	Intelligent transportation systems – Cooperative ITS – Using V2X and V2V communications for applications related to signalized intersections (ISO/TS 19091:2019)
IEEE 802.11-2012 (or later)	Institute of Electrical and Electronics Engineers (IEEE) Standard for Information technology-- Telecommunications and information exchange between systems Local and metropolitan area networks--Specific requirements Part 11: Wireless LAN Medium Access Control (MAC) and Physical Layer (PHY) Specifications
IEEE 1609.2-2022 (or later)	IEEE Standard for WAVE -- Security Services for Applications and Management Messages
IEEE 1609.4-2022 (or later)	IEEE Standard for WAVE -- Networking Services
SAB 02735 SEP2023 (or later)	V2X Communications Message Set Dictionary
SAE J3268 MAR2023 (or later)	Listing of Provider Service Identifiers and Associated Application Technical Reports
IEEE 802.3-2022 (or later)	Standard for Ethernet
FCC Title 47, Parts 2, 15, and 90	Federal Communications Commission (FCC) Code of Federal Regulations (CFR)

CV equipment shall include hardware, software, ancillary devices, and all material necessary to enable wireless V2I communications. Ensure that all assembly

Figure 3-23: Developmental Specification for Connected Vehicle Roadside Equipment, Sections and 681 and 695

The Engineer should coordinate with the District to determine if the roadside unit is required to include a separate Bluetooth® interface providing dual functionality. Below is an example of TSP language used to procure a Bluetooth® interface:

Bluetooth® Interface: The RSU must include automatic vehicle identification (AVI) detection functions using Bluetooth® technology. Bluetooth® interfaces must collect and forward anonymous Bluetooth® data, including vehicle identifier, time, and detector location information. Unit must be capable of providing MAC addresses in a format that can be utilized by the existing statewide Bluetooth® central software maintained by the Department. If the unit is unable to provide the appropriate format natively from the unit, an open-source encoder module should be provided at no additional cost to the Department.

In the event the project requires the inclusion of a proprietary product, the Engineer will be responsible for the development of a Modified Special Provision (MSP) to capture the specific manufacturer and model required. Each MSP will need to be submitted and approved by Central Office prior to inclusion within the Contract Documents.

3.2.3.1 Testing Requirements

The current version of the Developmental Specification includes language related to the minimum requirements for testing to validate the equipment is properly installed and functioning as intended. **The Engineer of Record is responsible for determining if the minimum testing requirements meet the specific project needs or if additional tools, materials, testing equipment, or procedures are necessary.**

The EOR will be responsible for coordination with the District or local maintaining agency to determine if additional testing tools or procedures are required to be developed to ensure sufficient functional verification of equipment and systems. For example, determine if the project will include advanced applications that are not addressed by the minimum functional requirements and testing contained in the current Developmental Specification. Similarly, identify whether the District or local maintaining agency have the ability to perform any degree of testing using in-house resources (e.g., pre-existing operations of CV equipment; available OBUs or specialized testing equipment available for loan to the Contractor).

Best Practice: The Engineer of Record will be responsible for coordination with the District and/or local maintaining agency to determine if additional testing tools or procedures are required to be developed to ensure sufficient functional verification of equipment and systems. (i.e., OBU may be needed to test RSU).

The preference of the Department is to utilize the existing Developmental Specification in its current format with no modifications. However, when necessary, the EOR will be able to coordinate with the District Specifications Office, Central Office, and the monitor (i.e., Department sponsor) of the Development Specification to modify or expand the requirements contained in the current version to address additional project-specific needs. Following Central Office approval, the EOR will be responsible for developing and taking ownership of a Technical Special Provision (TSP) based largely on the Development Specification with only the necessary modifications tailored to the specific project needs.

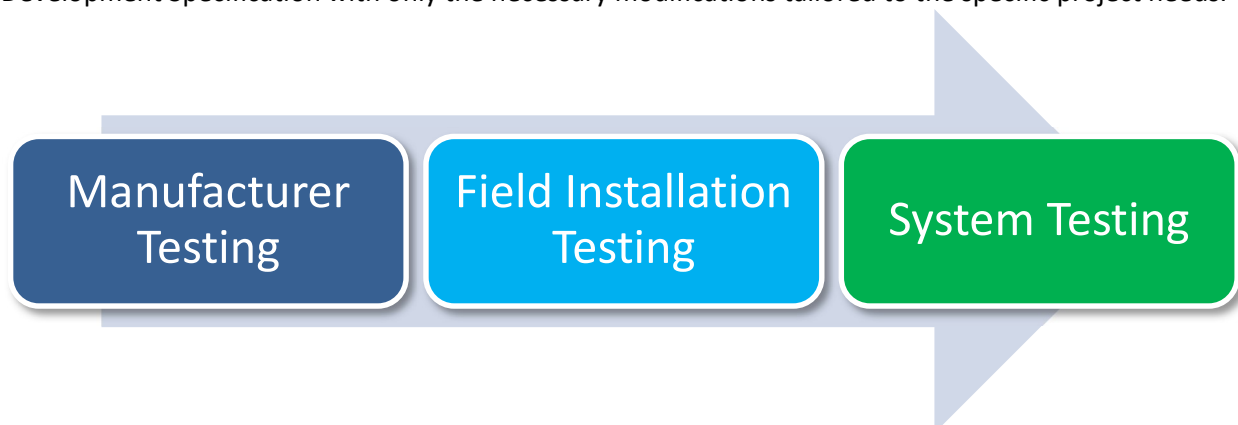

Figure 3-24: Connected Vehicle testing includes multiple steps to complete the process

The comprehensive process to properly test CV installations includes manufacturer testing, field installation testing, and system testing. High-level descriptions are provided below:

- **Manufacturer Testing** – performed by the vendor before the equipment leaves the factory, this testing procedure verifies the device(s) is configured and operating properly. The manufacturer is responsible for the integration of each roadside unit within the statewide SCMS platform before shipping to the Contractor. The manufacturer, or their authorized representative, is also required to preconfigure communication settings and develop a MAP file for each RSU. *The EOR is not expected to be involved in this phase of testing.*
- **Field Installation Testing** – performed by the Contractor, this series of on-site inspection and testing activities will verify that all infrastructure construction is completed per the relevant standards, specifications, Contract Documents, manufacturer’s recommendations, and Construction Engineer directives. The first portion of field installation testing can often occur on-site without requiring network connectivity or communications to other systems. Testing activities usually apply pass-fail criteria, which can be assessed through visual or manual inspection, or by connecting a laptop directly to the device. The second portion of field installation testing involves subsystem testing to confirm data exchange between the field site and other system components. Subsystem testing almost always requires that the field site has network and internet connectivity.
- **System Testing** – performed by the Contractor, this series of testing activities is used to demonstrate the successful operation of CV applications, as well as the end-to-end functionality of the CV system(s) and successful integration with other devices and systems. This phase of testing requires network connectivity between the field device(s) and the central software providing command and control (e.g., SunGuide). Multiple iterations of individual testing activities may be required during this phase to successfully prove the receipt and transmission of all messages and implementation of applications. This testing phase will also require the Contractor to provide a testing-ready OBU enrolled in the statewide SCMS platform. CV system testing is often included as part of a project’s ITS System Acceptance Test that includes functional verification of all ITS systems and devices.

Refer to **Section 5 – Construction** for additional information related to testing requirements and procedures.

681-4.2 Manufacturer Testing: Ensure that the manufacturer has performed production testing on all RSE to verify proper operation prior to shipment, including successful enrollment of RSUs within the FDOT SCMS production environment.

681-4.3 Field Testing: Once the CV equipment has been installed, conduct local field acceptance tests at each field site according to the submitted test plan. Perform the following:

1. Verify that physical construction has been completed as detailed in the Plans.
2. Verify all wire and cable connections are correct and secure.
3. Verify proper voltages for all power supplies and related power circuits.
4. Connect devices to the power sources. Verify that the power LED on roadside equipment illuminates.
5. Log in to CV equipment and verify access to user interface.
6. Verify the configuration of CV equipment network interfaces.
7. Confirm the RSU can communicate with the FDOT SCMS, verify that downloaded security certificates are current, and verify automatic certificate top-offs.
8. Verify RSU data exchange to and from vehicles equipped with an OBU capable of message display.
 - a. Verify MAP, SPAT, and TIM message broadcast.
 - b. Verify BSM receipt and forwarding by RSU.
9. Verify local functionality of CV applications.
 - a. MAP, SPAT, and TIM functionality
 - b. Vulnerable Road User warning functionality
 - c. Red light violation warning functionality
 - d. Preemption and priority functionality

611-5 ITS System Acceptance Test.

After the stand-alone tests have been completed and approved by the Engineer, perform the System Acceptance Test in the presence of the Engineer and, when applicable, a representative of the agency designated to accept maintenance responsibility.

Conduct an approved 30-day System Acceptance Test during which all ITS Systems, Sub-Systems and, at a minimum, all control, monitoring, and communication functions of the field equipment are evaluated from a Transportation Management Center (TMC). Complete the System Acceptance Test documentation and turn them over to the Engineer for approval.

During the 30-day test period, limit device outages to 10% or less, a minimum of a single unit if less than 10 devices or the allowable threshold required in the Contract Documents, whichever is less. Should an outage of more than 10% of the total number of devices occur, a single unit or more if less than 10 devices or the allowable threshold in the Contract Documents, then the System Acceptance Test has failed.

Upon the failure of the System Acceptance Test, the 30-day testing window shall pause until all devices are fully functional. In addition to pausing and extending the test period by the number of days lost by failure and repair time, the Engineer has the option of restarting the full 30-day test.

Upon the successful completion of the System Acceptance Test, the Engineer will submit to the Contractor a letter of approval stating the first and last day of the 30-day system test period.

Figure 3-25: Excerpts from Developmental Specification and Standard Specification identifying subdivided portions of CV device manufacturer and field installation testing as well as ITS System Acceptance Test

Based on the specific functionality of the system, the EOR may need to add or modify language within the Developmental Specification to ensure the Contractor is provided clear directives for the required testing. The following are examples of criteria that may be included:

- For projects with RSUs installed on signalized intersections, add...*Confirm the RSU can communicate with a terminal located on the local maintaining agency's network, verify data exchange across network firewalls.*
- For projects with vulnerable road users detection and safety systems for bicyclists, pedestrians, and micro-mobility users, add...*Verify RSU data exchange to and from vehicles equipped with an OBU capable of message display; verify Personal Safety Message (PSM) broadcast.*
- For projects with emergency vehicle preemption (EVP) or transit signal priority (TSP), add...*Verify RSU data exchange to and from vehicles equipped with an OBU capable of message display; verify Signal Request Message (SRM) and Signal Status Message (SSM) transmission and receipt. Verify that Signal Controller goes to preemption or priority SOP and back to normal SOP as needed.*
- For projects with multi-function RSU including a Bluetooth® interface, add...*Verify automated vehicle identification (AVI) performance requirements in accordance with Section 660-4.*

^x Florida Department of Transportation Systems Engineering and Intelligent Transportation Systems (ITS) Architecture Procedures (750-040-003-d) is available through the FDOT Procedure Document Library - <https://pdl.fdot.gov/Procedures>

Section 4: Material Procurement Considerations

The purpose of this section is to provide considerations for materials procurement involving CV systems. The materials needed for CV deployment and operation will differ based on the project operational goals, location of project, and other systems involved. For example, CV projects along arterial corridors typically involve more systems and components than deployment on the interstate system (e.g., traffic signal controllers, controller firmware version needed for preemption and priority, etc.).

4.1 Roadside Units and Equipment

Roadside Equipment (RSE) that includes CV Roadside Units (RSUs) and optional edge processing devices are common components found in CV environments. These devices are typically installed alongside roads and highways to facilitate communication between vehicles and transportation infrastructure.

Purpose: RSUs serve as wireless communication hubs, enabling seamless interaction between vehicles and the surrounding infrastructure.

Location: They are strategically placed along roadways to provide wireless communication coverage in specific areas.

Communication: RSUs communicate with vehicles using technologies like Dedicated Short-Range Communications (DSRC) or Cellular Vehicle-to-Everything (C-V2X). Following the FCC regulations and industry trends with respect to CV, FDOT plans to operate all RSUs in the C-V2X mode in the future. Therefore, all future projects must include C-V2X functionality.

Data use and Transmission: RSUs can receive data from CV, such as their current speed, heading, and other vehicle status information. This information can be used to produce traffic data concerning traffic speed, road conditions, and incidents like crashes. RSUs can also transmit relevant information to CVs, enabling notifications to drivers and other road users about conditions ahead, traffic signal information, congestion, safety, incident, or weather information.

In summary, RSUs and associated RSE play a vital role in enhancing safety, efficiency, and overall effectiveness of CV systems.

Considerations for Material Procurement Specification of an RSU (lessons learned)

- Use CVRSE (Connected Vehicle Roadside Equipment) Developmental Specification 681 and 995 with Central Office collaboration (Dev681CVRSE and Dev995CVRSE) [\[hyperlink\]](#)^{xi}
- Communication and Protocol and Frequency Supported
- Generation/Edition, Production levels and Lifecycle
- Support Levels, and Warranty Support considerations.
- Communications and Cell Service, if applicable
- Software and Firmware updates are often required for other devices to enable CV functionality (e.g., controller firmware updates).
- Shoulder mounted (e.g., using vertical poles or on/near upright of mast arms), or overhead mounted (mast-arm or span-wire). See Design Chapter 3.
- Mounting Hardware that may be necessary depending on the type of procurement and expected installation method. See Design Chapter 3.

- Integration and/or Enrollment in central systems
 - Security Credential Management System (SCMS) Enrollment
 - SunGuide®
 - Vehicle-to-Everything Data Exchange Platform (DEPOT)

4.2 On-Board Units

An On-Board Unit (OBU) is a device installed within a vehicle as part of a CV ecosystem. Its primary purpose is to enable communication between the vehicle and the transportation infrastructure, it can also enable communication between other CV equipped vehicles. OBUs play a crucial role in the context of CV technologies, supporting V2I, V2V, and V2X communication.

Best Practice: If OBUs are part of a CAV project, the following resources from FDOT’s earlier projects should be reviewed, leveraged, and consulted during project development, procurement, construction, integration, and acceptance steps:

- District Five Connected Vehicle On-Board Units (DOT-RFP-22-5004-ONBU)
- District Five Connected Vehicle On-Board Units Lessons Learned
- District 7 Connected Vehicle On-Board Units

Function: OBUs facilitate bidirectional communication between the vehicle and external entities, including other vehicles, roadside infrastructure, and traffic management systems.

Location: Eventually, these units are expected to be integrated into the onboard electronics systems of future production vehicles. Currently, most are aftermarket devices that are permanently or semi-permanently installed in vehicles or are portable units that can be moved to different vehicles for the purposes of overall CV system testing and demonstration.

Communication: OBUs communicate with RSUs and Other OBUs using DSRC or C-V2X to exchange information.

Data use and Transmission: OBUs generate, and broadcast data related to vehicle status, location, speed, and other relevant information in real time. The data can be received and used by other CV ecosystem components, including other vehicles (V2V) and the roadside infrastructure (V2I). Some OBUs, if internally connected to the vehicles Control Area Network (CAN) bus or On-Board-Diagnostics (OBD) port, can obtain additional information such as wind-shield wiper status, brake status, or seat belt-status.

Additional Applications: Some OBUs can have additional applications for safety, such as collision avoidance warnings, passing sight distance assistance, pedestrian or bicycle warnings, or other road hazard warnings. Other OBUs applications can prioritize emergency vehicles and public transit vehicles by creating a special request to traffic signals. OBUs can contribute to better traffic flow, lower environmental emissions by providing real-time data on traffic signalization and road conditions, like congestion and construction.

Security: Dedicated OBUs that utilize DSRC or C-V2X communication are designed to be secure and resistant to unauthorized access. Furthermore, data from OBUs is typically anonymous to prevent the transmission of any personally identifiable information.

In summary, OBUs are essential components that enhance safety, efficiency, and connectivity in the realm of CVs.

Considerations for Material Procurement Specification of an OBU:

- Agency procurement of OBUs should be consistent with FDOT’s CAV 2.0 Strategic Plan and driven by FDOT District Traffic Engineering and Operations Office’s guidance.
- Communication and protocol and frequency supported.
- Cellular connection for SCMS certificate top-off
- Generation/edition, production levels and lifecycle
- Support levels (LTS – Long Term Support 5+ Years), or deprecated.
- Software and firmware updates
- Additional applications supported.

Note: some applications may not be supported in the default or base configuration of an OBU. Some novel and innovative applications may also require substantial development time and costs. Certain applications may only be feasible at economies of scale and deployment quantities. The EOR should take care to develop and clearly describe cases, business cases, and the value of applications to the client (i.e., the Department, Local Agency, Transit Agency, or Emergency Response organization). Below are some OBU applications to consider:

- Signal Phase and Timing
 - Countdown to Green
 - Per Approach only regardless of lane usage or include left turn or overlap phasing based on the geo-location per lane (Lane-specific logic or displays may require OBE/OBU with higher GPS accuracy, more precise placement of OBU antenna, and vehicle-specific calibration).
- Emergency Vehicle Pre-emption
- Transit Signal Priority
- Advance Traveler Information warnings
 - Travel Times
 - Congestion
 - Expected Delays
 - Lanes Blocked (Temporary/Short Duration)
 - Lanes Closed (Long Term Duration)
 - Adverse Roadway Conditions
 - Adverse Weather Conditions
 - Optional and/or required detour
 - Special Events
 - Planned Construction Activities
 - Planned Maintenance Activities
 - Local Identifiers (Airport, Hospital, Sporting, Venue, Attractions, Historical Districts)
 - Public Safety Announcements
 - AMBER (America’s Missing Broadcast Emergency Response) Alerts
 - Silver Alerts
 - Bridge and Weigh-In-Motion (WIM) Opening and Closing
 - Other related broadcast alerts (as defined)
- Queue Warning
- Reduce Speed Zone Warning
- Pedestrian in Signalized Crosswalk
- Forward Collision Warning

- Vehicle Turning Right in front of an Emergency or Transit Vehicle
- Curve Speed Warning
- Other Novel applications
- Integration and/or enrollment to central system
 - SCMS enrollment
 - SunGuide®
 - DEPOT
- Form Factor, use-case, and agency preference in vehicle (i.e., In dash/console embedded, separate monitor, embedded in rear-view mirror, heads-up display projector, Nav system embedded).
 - Audio and Visual interface for delivery of warnings, alerts, notifications, information, and other messages to the vehicle operator
 - Use-Cases such as Priority (with a Bus Driver as the end-user), Pre-emption (with an EMT/Paramedic as the end user), Road-Ranger, or Signal information (SPaT) may have different form factor and audio/visual needs.
- Antenna mounting type (i.e., permanent installation, semi-permanent, or portable)

4.3 Other Devices to Consider in Materials Procurement for a CV Project

The devices in the lists below may vary depending on what type of CV applications and use cases are intended for a particular project. Care and due diligence must be taken to only incorporate relevant devices and materials within a procurement document.

Controller Related Procurement:

- Controller upgrade if the controller is not an ATC (Advanced Transportation Controller)
- Compatible malfunction management unit (MMU) and bus interface unit (BIU) for an upgraded ATC Controller
- CV capabilities for controller may require a firmware upgrade, license, or additional cost for activation.
 - Review CV compatibility based on the project requirements (i.e., data output in standard SAE J2735 formats, ability to send data to more than one destination)
 - Controller firmware version should allow proper communication with RSU and implementation of CV applications (i.e. TSP, EVP).
- Cabinet and equipment space
- Controller phasing and timing modifications as needed to accommodate intuitive CV experience so that field indications are displayed properly in the OBU. (i.e. Flashing Yellow Arrow, and other variation in protected/permissive phasing; Overlap Phasing, Phase and Ped Omits, Bicycle Signals, Exclusive Ped Phase and/or Leading Pedestrian Intervals, revisions to controller to accommodate TSP and EVP applications).

Specialized Communications for CV use

- Ethernet over fiber (e.g., new or upgraded Managed Field Ethernet Switches)
- LTE or cellular modems for remote applications and related cellular service cost
- Point-to-Point wireless bridges
- Switch upgrade consideration for available ports.
- POE and power supply considerations for switches and CV equipment

Specialized Edge Devices

- Any edge computing device that produces CV related messages as needed for specialized applications.
- Any edge computing device required to translate National Transportation Communications for Intelligent Transportation Systems (NTCIP) data to SAEJ2735 messages, translate other data for sharing between system components, or provide additional message forwarding capabilities.
- Any edge computing device hosting CV software such as IVP (integrated V2I prototype) Hub or other CV applications.

Specialized Detection System

- Video Detection Cameras
- InfraRed Cameras or other passive pedestrian systems
- Light Detection and Ranging (LIDAR) Sensors
- Other Detection Devices that generate geo-locations for CV uses

Specialized Cloud Applications, Central Systems and Mobile Applications

- Associated Cloud Hosting Cost for Cloud Applications
- Licensing Cost for functionalities (i.e., Person Detect for Bosch Cameras)
- Central Software Cost for CV or RSU Management
 - Kapsch - Connected Mobility Control Center (CMCC)
 - Iteris - VantageARGUS CV
 - Yunex - Concert, Acyclica Travel Time
 - Applied Information - Glance
 - Commsignia - Commsignia Central
 - Kyra - IntelliConnect
- Advanced Traffic Management Software (ATMS) Central Software cost for CV module/functionality and integration of upgraded controllers
- Mobile Applications and pseudo OBU emulations using mobile devices.

Specialized Integration Services

- Integration cost or time associated with Central Office Software
 - SCMS
 - SunGuide®
 - DEPOT

4.4 Other Devices Considered incidental in Materials Procurement for a CV project

Listed below are examples of materials that should be considered incidental in most project types. Procurement documents should make it clear that the installation contractor is required to provide incidental materials as needed to create a complete and functional system.

- Wire, cable, and other incidental construction and installation materials.
- POE (Power over Ethernet) injectors, SPD (surge protective devices), and other power supply related equipment. Surge protection should be considered incidental to other devices per the FDOT Standard Specifications for Road and Bridge Construction and Developmental Specifications. Per FDOT requirements, the RSU manufacturer must include a power supply, PoE injector, and any power converter required with their device.
- Consider what additional mounting hardware may be required for a particular installation. Some mounting hardware and brackets may be provided with the device by the manufacturer, but

projects often also require additional brackets that must be provided by others (e.g., pole mounting saddles, straps, risers, etc.).

^{xi} [Dev681CVRSE](#) and [Dev995CVRSE](#) - Connected Vehicle Roadside Equipment and Connected Vehicle Roadside Equipment
Materials can be found at: <https://www.fdot.gov/specifications/developmental-specifications>

Section 5: Construction Considerations

This chapter is intended to share guidance and best practices around the construction phase of a CV deployment project. These guidelines are geared more towards the Construction project manager (PM) as they oversee the completion of the CV construction project. The most crucial element in advanced technology deployment like CV, the role of device configuration and integration with other ITS systems can vary depending on the project approach, while installation will be the responsibility of construction contractors in all cases.

5.1 Contract Types

FDOT uses several contracting mechanisms to procure and deploy CV equipment throughout the state. Regardless of the adopted contract type, FDOT develops the requirements, design, draft concept of operations, and other systems engineering documents. The project types and procurement methods are selected based on project needs and Department policies and procedures. The most used procurement types in the state are:

- **Design-Bid-Build:** In this type of contract, FDOT or another agency enlists the services of a design consultant to develop and complete Plans and Specifications that can be incorporated into a standard bid package used to separately advertise and select a contractor for construction.
- **Design-Build:** FDOT has also been using the Design-Build procurement method to deploy CV projects. In this procurement type the contractor will design, provide devices, construct, integrate, and perform maintenance activities until project acceptance.
- **Systems Manager:** Several CV projects in the state have used this procurement method. In this method the Department first selects a systems manager/consultant to assist the Department in design, construction oversight, and post-construction stages. The Systems Manager will assist the Department with developing the 100% design plans and specifications, systems engineering documents and post construction integration. The Department may procure devices through an invitation to bid, request for proposal, or through the contractor as part of the bid package. The complete Plans and Specifications package will be used to advertise and select a contractor for construction.
- **Request for Proposal (RFP):** FDOT uses the typical RFP process to acquire the vendors and CV devices. Following are some highlighted features used in the RFP process:
 - Some Districts have been using the value-added services in the price proposal form and in the scope of services, allowing the industry to offer the optional services and cost. If FDOT needs these services, they can avail them for the quoted price in the price proposal. [[Procurement Manual - 375-040-020](#)]^{xii}

Additional information concerning acquisition of professional services, contractual services, and commodities by FDOT can be found on the Department's [Central Procurement Office](#) webpage.^{xiii}

5.1.1 Design-Bid-Build

Design-Bid-Build is a method of contracting and project delivery which the owner selects and contracts with a Designer initially to design the project. Thereafter, the owner utilizes the finished design to bid out the project and selects a contractor. In FDOT projects the Designer is selected after Concept Planning, then the Designer produces a set of plans that goes through periodic reviews (i.e., 30%, 60%, 90%, Constructability, Biddability) and subsequently finalized. The final design and specifications are then put

out to bid, inviting contractors to submit their best price for completing the project. The contractor is then chosen and constructs the project according to the provided plans and specifications.

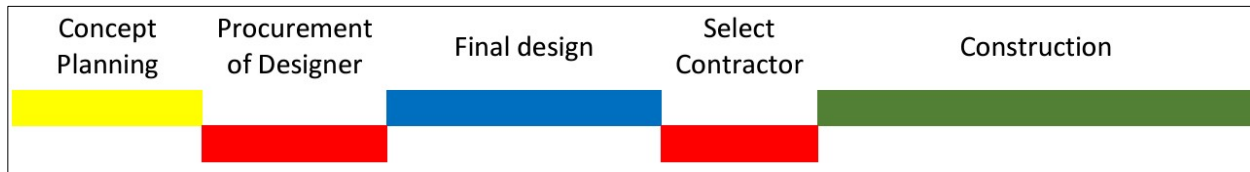

Figure 5-1: Visualization of Project Delivery for a Design-Bid-Build

Pros:

- Only Concept Planning/Stage 2 Scope is required. The designer starts all designs from concepts.
- More opportunities for comments from partners (i.e., Districts, Local Agencies, and other stakeholders).
- The Designer works under the direction of the Department and its partner agencies. Therefore, the Designer generally advocates for those entities during and after design (e.g., as part of general project coordination and during construction).
- Since the project's design is completed before the bidding phase, the Department can clearly define the project scope and requirements, reducing the likelihood of change orders and disputes during construction.

Cons:

- Longer timelines for procurement process (i.e., selection of design firm initially, then selection of contractor after final design).
- Potential post design services may be required.
- For ITS and/or Transportation Technology projects, Systems Integration may not be fully addressed in the project if it is not well defined and detailed in system Design. Due to project lifecycles, ongoing changes in agency networks and systems, and other factors it is almost impossible to fully detail certain aspects of integration in traditional Plans and Specifications. Therefore, the Plans and Specifications usually require a broad statement concerning coordination among the Contractor, FDOT, and the local agency to ensure details such as network settings and other configuration/integration activities are addressed during construction (and preferably with the Design EOR and team involved through post-design services agreements).
- Difficult procurement methodology for projects with software development requirements.

5.1.2 Design-Build

Design-Build is a method of contracting and project delivery in which the designer, equipment vendor, and the contractor act as one entity under a single contract with the project owner. This single entity, the Design-Build team, provides services for both the design, material procurement, and construction until final completion and project acceptance. In FDOT projects, the Design-Build team is selected after initial Concept Planning and Preliminary Design.



Figure 5-2: Visualization of Project Delivery for a Design-Build

Pros:

- Single Procurement process and timelines for a combined single entity. This compresses timelines for faster project delivery.
- Design-Build encourages collaboration between the designer and contractor from the beginning of the project.
- The contractor can start on portions of the project that are already defined without necessarily waiting for 100% design completion; thus accelerating timelines and possibly uncovering logistical, unforeseen/unplanned circumstances and addressing them pro-actively.
- All aspects of successful project completion are the responsibility of a single entity.
- Traditionally, low risk and low complex projects can be completed quickly without the need for concept plans or preliminary design.
- Could be a good fit for grant applications. Easier to package all requirements under a single contract which allows the contractor to meet those requirements with flexibility through design and construction phases.

Cons:

- More than Concept Planning is required. Preliminary Design should be completed prior to selecting a Design-Build Team.
- For ITS and/or Transportation Technology projects, Systems Integration may not be fully addressed in the project if not well defined in the Preliminary Design.
- Depending on the complexity of the project, the agency may encounter several claims by the contractor to make up for project delays or cost overruns that the contractor did not account for.
- Please note that the Central Office will need to approve the adoption of the Design-Build procurement method.
- Requirements may be interpreted differently than intended, care should be taken to write and communicate accurate and clear requirements to ensure the desired outcome.

5.1.3 Systems Manager

Systems Manager projects are an adaptation of the Design-Bid-Build process whereby FDOT-selected consultant firms provide a variety of professional services to the Department or Agency in support of successful overall project design, construction, integration, and testing. This often includes performing device evaluation as part of their design process, developing plans and specifications, producing various procurement and construction documents, and providing technical and professional services as FDOT's representative during subsequent construction oversight and associated system integration activities. Ultimately, the Systems Manager is responsible for delivering the project to the Department.

Pros:

- The Designer works under the direction of the Department and its partner agencies. Therefore, the Designer generally advocates for those entities during and after design (e.g., as part of general project coordination, design, and subsequent construction/systems integration).
- Allows the design team to provide a variety of professional services and technical support during all phases of the project.
- More opportunities for direct engagement between Districts, Local Agencies, other stakeholders, and design/integration team members.
 - This includes stakeholder meetings with all agencies.
- Ability to host technical meetings with each agency's IT department to communicate the projects' technical needs in advance for issues such as:
 - Network design and device configurations.
 - Firewall and security requirements
 - Server and application needs
 - Inventory tracking
 - Lab testing
 - Device storage, configuration, and deployment
 - Testing
- Track and document lessons learned.
- Systems Manager provides a continued service from design through integration, which makes the overall deployment seamless to the FDOT's implementation team.

Cons:

- Additional professional services provided by the Systems Manager typically add more cost (e.g., additional services and collaboration during design as well as during construction oversight, support, and integration). Accordingly, programming funding can be difficult pending the scope and depth of the project.
- Complexity for contractors in regard to handover testing, schedule, and standalone testing of devices due to the systems manager process. This needs to be clearly defined in the project specifications for the contractor to bid on the project correctly.
- Potential for confusion with accountability/finger pointing with less experienced/hands-off Systems Manager and Contractor.
- Systems Manager requires a design consultant that is well versed in integration; however, that skillset is relatively new and limited.

5.1.4 Other Project Coordination Considerations

Below are other project coordination considerations.

- Did the project manager/Systems Manager reach out to other similar CV project staff to discuss current events with CV industry and/or vendor or software providers that may affect upcoming project?
- The project manager/Systems Manager should review similar projects and obtain lessons learned and other documentation that would be beneficial to apply to project.
- Are there any other projects scheduled within the rights-of-way that may be simultaneous with the plan deployment (i.e., interchange ramps, resurfacing, permit Jobs not only from FDOT but also including third party fiber/telecom contractors and utilities, environmental permitting, rail

certification etc. Consideration for other projects from State or Local Government entities such as Universities, Cities, Counties or Water Management Districts)?

- Is the equipment, particularly related to technology equipment, available, in production (not obsolete) and without supply chain delays?
- Is all related technology equipment, particularly network, telecom, radio, or video surveillance compliant with applicable Federal, State, and Local Laws (i.e., NDAA/National Defense Authorization Act of 2019) and are cybersecurity compliant for critical field infrastructure?
- Has the owner, designer, contractor, and integrator specified and agreed on the responsibilities in collaboration with the maintaining agency for various logistics including, but not limited to, emergency callouts, network topology, schema and integration, effects on broader network operations, and public records compliance particular to records request and operations logs in the event of a crash or accident.
- At the conclusion of each project, a post-debrief, lessons learned should be documented and shared, and possibly incorporated in the updated lessons learned document.

5.2 Configuration, Installation, and Integration

Refer to **Appendix A.1.1** for Configuration, Installation and Integration lessons learned.

The success of a CAV project in operation and maintenance depends on the proper configuration, installation, and integration during the construction phase leading to timely acceptance of the project. Sections 5.2.1 through 5.2.7 include various aspects of integration aspects. The following table provides a matrix of roles and responsibilities, where the specific roles and responsibilities will need to be determined based on the adopted procurement method.

<u>Responsibility</u>	<u>Lead Role</u>	<u>Support Role</u>
FCC Data Collection and Site Registration	<ul style="list-style-type: none"> • Designer • Construction Contractor 	<ul style="list-style-type: none"> • FDOT District TSM&O • FDOT CO CAV
MAP Development	<ul style="list-style-type: none"> • Device Vendor* 	
SCMS Provisioning	<ul style="list-style-type: none"> • Device Vendor* 	<ul style="list-style-type: none"> • FDOT District TSM&O • FDOT CO CAV
DEPOTIntegration	<ul style="list-style-type: none"> • RTMC IT Staff** • Contractor/Systems Manager** 	<ul style="list-style-type: none"> • FDOT CO CAV
RSU HMS Integration	<ul style="list-style-type: none"> • RTMC IT Staff** • Contractor/Systems Manager** 	<ul style="list-style-type: none"> • FDOT CO CAV
Managing and Tracking Device Information	<ul style="list-style-type: none"> • RTMC IT Staff • Local Agency Staff 	<ul style="list-style-type: none"> • FDOT CO CAV

* - these steps take place during Construction Phase

** - these steps take place during Construction project acceptance phase

5.2.1 Network Access and Security

Refer to **Appendix A.1.2** for Network Access and Security

5.2.2 FCC Data Collection and Site Registration Process

RSUs and any other CV device that broadcasts data using the portions of the 5.9GHz radio band that the FCC has assigned for public safety use must be licensed to operate. FDOT has a statewide license for the operation of RSUs in the frequency range from 5.895GHz – 5.925 GHz (the upper 30MHz (Megahertz) portion of the 5.9 GHz spectrum that is dedicated for operation of C-V2X devices).

All RSUs in Florida, whether owned and operated by FDOT or local maintaining agency partners, must be registered under the FDOT license (call sign WQBS407). This is especially important since the Department has been granted a waiver by the FCC with statewide scope that authorizes the use of C-V2X technology while the FCC finalizes rules for licensing C-V2X devices in the future.

The process for registering a RSU location as a radio site under the FDOT call sign is generally as follows:

- The local FDOT District TSM&O staff (working in conjunction with their local maintaining agencies, project consultants, etc.) notifies the [Central Office ITS Communications Administrator](#) or ITS-Communications-Administrator@dot.state.fl.us^{xiv} of need for site registration(s) and expected installation date. This notification should preferably be provided approximately 3-6 months before the equipment is expected to be installed and operating.
- The FDOT CO Communications team will provide their latest data collection spreadsheet that explains the information needed for site registration. The requestor must complete and return the spreadsheet. The FDOT CO Communications team will then review the request and enter the information for each RSU location in the FCC Universal Licensing System (ULS). A sample of the information required is shown in the figure below.

	A	B	C	D	E	F	G
1	Site Data			Imperial Elevation Reference Information			
2	Proposed Site Name:	D535133OrlanMaitl		Elevation of Site AMSL:	78.00	Feet	
3	Antenna Latitude (XX° XX' XX.X" N):	28°37'19.9"N		Pole Height w/out App:	27.00	Feet	
4	Antenna Longitude (XX° XX' XX.X" W):	81°21'50.7"W		Pole Height with App:	27.00	Feet	
5	City:	Maitland		Elevation of Device AGL:	25.00	Feet	
6	County:	Orange		Center Line of Antenna AGL:	26.00	Feet	
7	State:	Florida					
8	Major Street or Corridor:	US 17/92 (Orlando Ave.)					
9	Minor Street or Milepost:	Maitland Ave./Manor Rd.					
10	Elevation of Site Above Mean Sea Level (AMSL) in meters (calculated value):	23.8					
11	Overall Height Above Ground Level (AGL) without appurtenances of the support structure in meters (calculated value):	8.2					
12	Overall Height Above Ground Level (AGL) with appurtenances on the support structure in meters (calculated value):	8.2					
13	Support Structure Type:	Mast Arm (UPOLE)					
14	Transmitter Antenna Data						
15	Manufacturer of the Antenna:	L-com					
16	Model Number of the Antenna:	HGV-4958-06U					
17	Antenna Gain in dBi:	6.0					
18	Beamwidth in degrees:	360.0					
19	Center Line of Antenna height AGL in meters (calculated value):	7.9					
20	Azimuth in degrees:	360.0					
21	Elevation Angle in Degrees:	0.0					
22	Transmitter Data						
23	Equipment Class: Choose the output power for the corresponding equipment class from drop down. Default is Class D. A= 0 dBm Max Output Power (15-meter communication zone) B= 10 dBm Max Output Power (100-meter communication zone) C= 20 dBm Max Output Power (400-meter communication zone) D= 28.8 dBm Max Output Power (1000-meter communication zone)	28.8					
24	Frequencies: Default is all.	<input checked="" type="checkbox"/> 5895 - 5905 MHz <input checked="" type="checkbox"/> 5905 - 5925 MHz					
25	Maximum Output Power (calculated value):	27.0					
26	EIRP (calculated value):	33.0					

Figure 5-3: Site Registration Data Collection Spreadsheet

- The data in the FCC ULS is public information and details concerning existing and pending site registrations, as well as other information, can be found at the following link to ULS records associated with call sign WQBS407 [[Hyperlink](#)].^{xv} The main page for WQBS407 information is shown in the figure below:

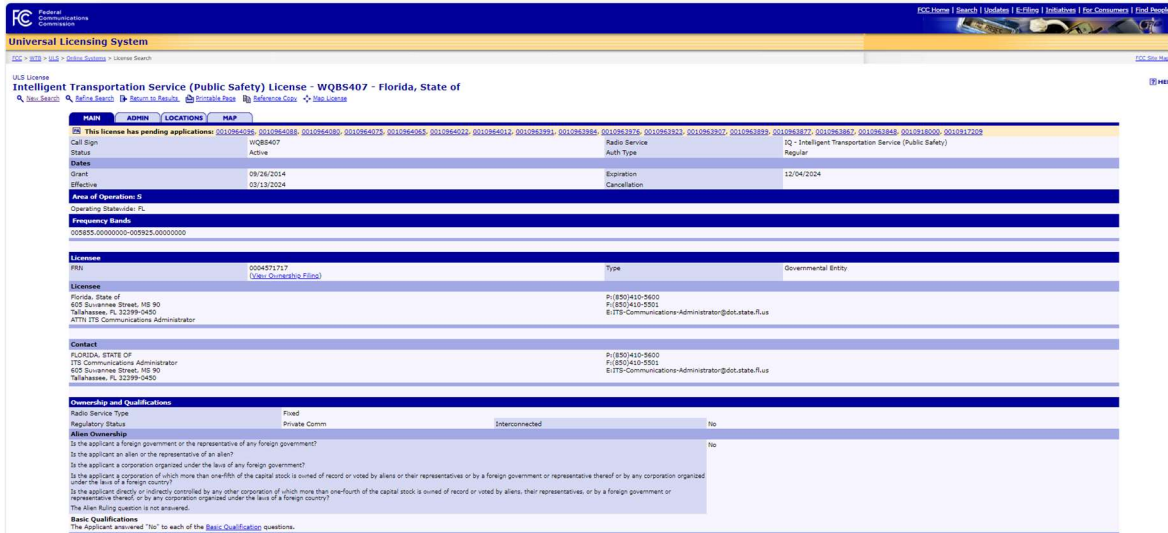

Figure 5-4: License information for WQBS407 on FCC ULS

Once an RSU site has been registered, the information associated with the equipment at that location should be kept up to date. If the RSU is replaced, relocated, or removed during or after construction, the corresponding site registration record in the ULS must be updated. The following are examples of changes that typically require ULS updates:

- The height of the RSU is increased to a point where it is more than 26 feet (26') above ground level (mounting heights above 26 feet (26') typically require that RSU output power be reduced, and site registration updated accordingly).
- The RSU is relocated more than 10 feet (10') from its originally recorded Latitude/Longitude (LAT/LON) without an increase in height.
- The RSU equipment has changed (e.g., different RSU assembly or use of different Antenna make/model).

Contact the FDOT CO ITS Communications team if an update to information contained in FCC ULS is required.

5.2.3 MAP Development Guidelines

Sections 5.2.3 to 5.2.7 describe additional Construction considerations, Lessons Learned, and best practices for tracking, compliance, software integration and testing. Although some responsibilities may be vendor and integrator specific, Systems Managers, project engineers, and practitioners should have basic familiarity of key concepts and processes.

MAP development is typically a vendor responsibility. FDOT [District 5](#)^{xvi} has created a detailed document that describes the MAP development process, including examples showing the use of the USDOT's CV tool for MAP creation, the Intersection Situation Data (ISD) Message Creator. The [ISD Message Creator](#) is an

online utility.^{xvii} Additionally, in 2025, the [Connected Vehicle Pooled fund Study \(CVPFS\)](#)^{xviii} has created detailed instructions of [MAP Guidance](#)^{xix}

Last is we have learned that certain MAP files from RSU vendors (Iteris), need to be explicitly programmed to sign MAP messages. Talk to your vendor support on how this is done. In the Iteris RSU it is a simple parameter change from “Signature=False” To “Signature=True”.

5.2.4 SCMS Requirements and Processes

Security Credential Management System (SCMS) enrollment is typically a vendor responsibility. The device vendors will ensure that they have completed the provisioning process with the FDOT’s SCMS certificate provider. The devices will be enrolled into the FDOT’s SCMS system prior to shipping them for installation. CVs rely on secure communication systems to ensure safe and efficient operation. SCMS plays a critical role in managing the security credentials of vehicles, ensuring their authenticity and integrity. Here, we outline the key requirements and processes involved in implementing an SCMS application for CVs, including the actions required by equipment manufacturers for completing the attestation process to enroll and provision devices in the FDOT SCMS.

The FDOT has an active CAV Program and CAV Business Plan. SCMS is a critical component of this CV environment. Currently, TrustPoint Systems, Inc., in partnership with Integrity Security Services, LLC (ISS) is the SCMS provider for FDOT. SCMS is internet hosted and provides security certificate services to secure CV messages being broadcast in Florida’s CAV ecosystem. The ISS team provides V2X Security Credential Management services and software, including Certificate Management System (CMS) software, through a centralized contract managed by FDOT Central Office (CO). Automotive and other industry partners are required to be interoperable with the national SCMS Manager requirements, at a minimum, to securely interact with FDOT’s CV infrastructure. CV roadside units (RSUs) and on-board units (OBUs) must be enrolled and provisioned in the FDOT CMS software by their manufacturer prior to delivery.

Definition of fundamental components of FDOT’s SCMS ecosystem:

- **End Entity (EE):** a device that sends or receives messages within the Connected Vehicle ecosystem, e.g., an RSU, an OBU, or an Aftermarket Safety Device (ASD).
- **Certificate:** a digitally signed file provided by the SCMS vendor’s CMS software that has a configurable expiration date and enables an EE receiver to trust an EE message sender and that the message is unaltered.
- **Attestation:** a process through which the SCMS vendor verifies that the CV equipment manufacturer has included a Hardware Security Module (HSM) and correctly implemented security as per USDOT and Crash Avoidance Metrics Partnership (CAMP) recommendations. Attestation must be completed by CV equipment manufacturers as a precondition to EE Enrollment.
- **Enrollment:** the enrollment process is the point where an initial trust relationship is established between a new EE and the rest of the SCMS infrastructure. All EEs that participate in the SCMS must be enrolled. Manufacturers able to meet attestation requirements will be provided with CMS software user accounts that enable them to enroll and provision devices.
- **Provisioning:** a process where an enrollment certificate and bootstrap file are uploaded into the EE where the information is used to request an initial set of operational certificates from the SCMS vendor’s CMS software website via network communications.

- **Compliance:** Adherence to relevant standards and regulations, such as the Institute of Electrical and Electronics Engineers (IEEE) 1609.2/1609.2.1 and IEEE Standard for Wireless Access in Vehicular Environments (WAVE).
- **Key Management:** The SCMS manages cryptographic keys used for securing communication between units and the SCMS. This includes generating and distributing encryption keys for secure communication and revoking and updating keys periodically to enhance security.
- **Monitoring and Logging:** The SCMS should continuously monitor, and log activities related to authentication, authorization, and key management. This includes recording access attempts and outcomes, logging key generation, distribution, and revocation events, and analyzing logs to detect and respond to security incidents.

To enroll an RSU or OBU with the ISS SCMS to obtain security certificates, device manufacturers must adhere to the following requirements and processes listed below.

Requirements:

- **Hardware Security Module (HSM):** RSUs and OBUs should have dedicated HSM to store cryptographic keys securely.
- **Secure Boot:** Implement a secure boot process to ensure that only trusted software is executed on the RSU or OBU.
- **Cryptographic Algorithms:** Use approved cryptographic algorithms for generating and managing keys, such as Advanced Encryption Standard (AES) for encryption and Elliptic Curve Digital Signature Algorithm (ECDSA) for digital signatures.
- **Message Authentication:** Implement message authentication mechanisms to ensure the integrity of messages exchanged between units and ISS.
- **Secure Communication:** Use secure communication protocols, such as TLS, to establish a secure channel between the RSU/OBU and ISS.
- **Identity Verification:** Verify the identity of the RSU/OBU using a unique identifier, such as a serial number or MAC address (Media Access Control).

Process to Enroll and Monitor:

- **Request:** Device manufacturers must work with their customers and the local FDOT District TSM&O Engineer to request approval from FDOT Central Office to enroll and provision devices within the FDOT SCMS. Information included in the request should consist of project device information (make, model, and quantity), Project FPID, District number, and Expected Date of Installation.
- **Key Generation:** Generate a unique key pair (public and private key) for the RSU/OBU using the HSM.
- **Certificate Signing Request (CSR):** Create a CSR that includes the public key of the RSU/OBU and submit it to ISS for signing.
- **Certificate Issuance:** The ISS will issue a security certificate for the RSU/OBU after verifying the CSR and ensuring compliance with security requirements.
- **Certificate Installation:** Install the issued certificate on RSU/OBU's HSM for secure communication and authentication.
- **Certificate Renewal:** Periodically renew the security certificate to ensure continued secure operation of the RSU/OBU.
- **Key Management:** Manage cryptographic keys securely, including key generation, distribution, rotation, and revocation, to maintain the security of the RSU/OBU.

- FDOT provisioner:** FDOT users have the capability of enrolling devices into the SCMS portal. However, the primary responsibility of device enrollment belongs to the device vendors. FDOT provisioner is going to support in exceptional circumstances. FDOT Districts are going to authorize the users for their respective Districts. **FDOT Districts are suggested to add the SCMS point of contacts in the procurement documents.**

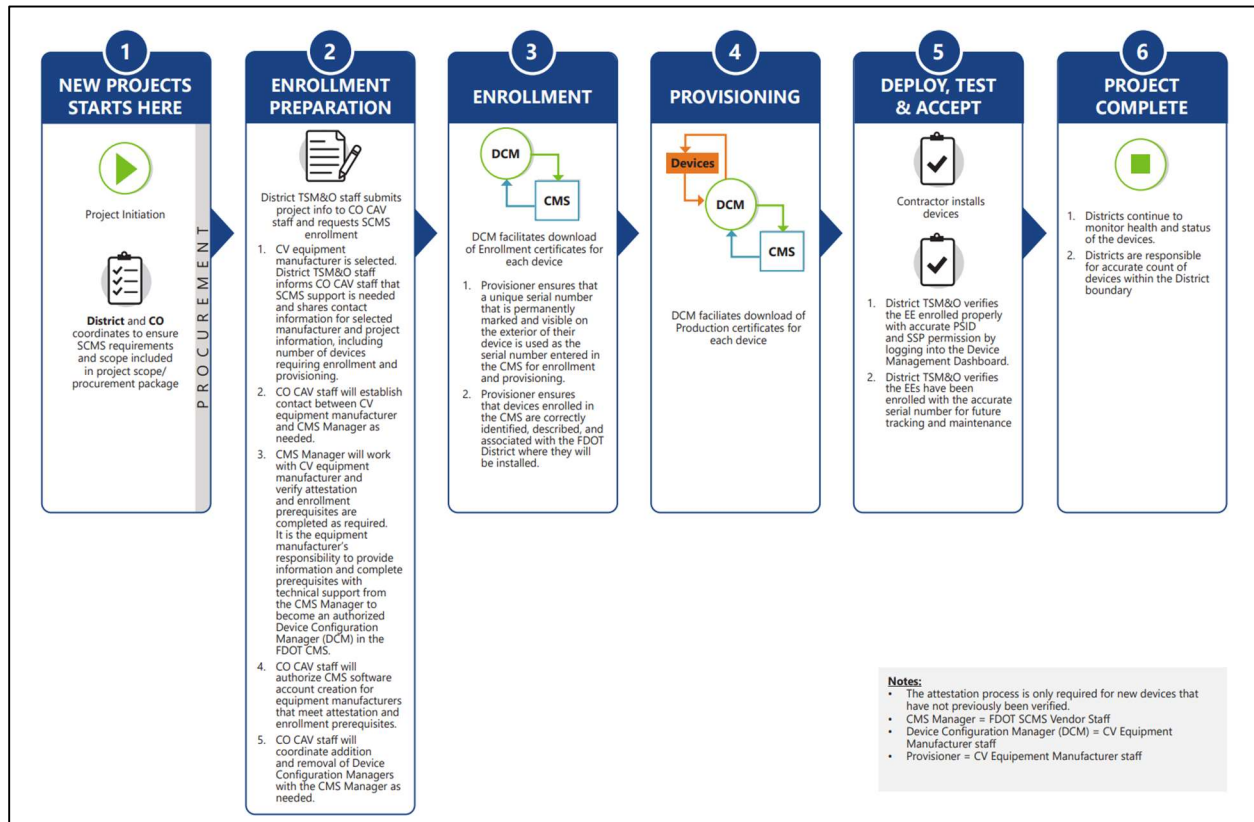

Figure 5-5: SCMS Enrollment Process

Enrollment and provisioning of devices requires that a Device Type and Enrollment Profile be selected within the SCMS portal for each device that is enrolled and provisioned. The Enrollment Profile selected determines which security certificates the SCMS will provide. These certificates are specific to individual CV message types. As new messages or applications are developed and introduced, it will presumably be necessary to update FDOTs Enrollment Profiles to accommodate their use. Similarly, it will likely be necessary to re-enroll and re-provision devices to utilize new profiles in the future.

For example, the Department recently decided that it would be beneficial to advance the use of the Sensor Data Sharing Message (SDSM) defined in J3224 for future safety applications. These applications involve roadside equipment detecting objects (e.g., unequipped vehicles, unequipped vulnerable road users, etc.) and RSUs broadcasting positional information on behalf of those unequipped objects. In order for SDSM messages to be signed with security certificates, a new profile had to be introduced in the SCMS to accommodate them as shown in **Figure 5.6**.

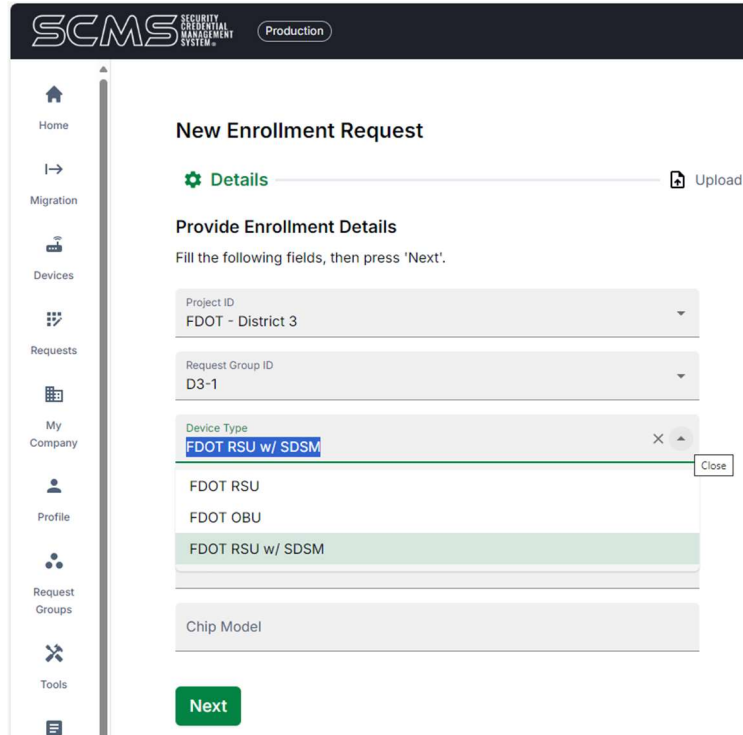

Figure 5-6: SCMS Device Type and Enrollment Profile Selection

The new profile “FDOT RSU w/SDSM” includes support for the SDSM message type in addition to the others that were supported in the previous “FDOT RSU” profile as shown in **Figure 5.7**.

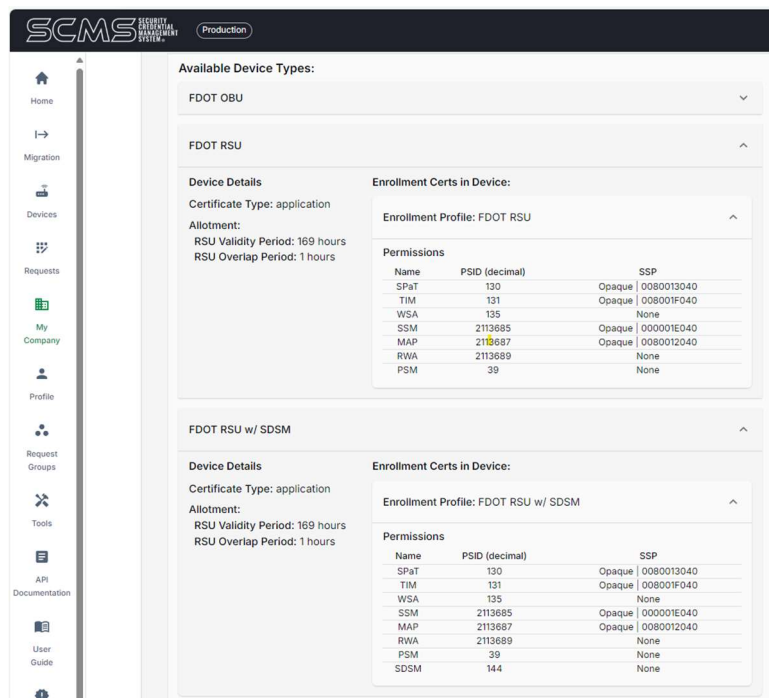

Figure 5-7: List of Certificate types in RSU Enrollment Profiles

FDOT prefers that RSUs on current and future projects be enrolled in the FDOT SCMS using the latest Provider Service Identifier (PSID) profile (i.e., the “FDOT RSU w/SDSM” profile shown in **Figure 5.7** above).

Work is currently underway to modify the FDOT Developmental Specification for Connected Vehicle Roadside Equipment to clarify that RSUs must support SAE J3224, V2X Sensor-Sharing for Cooperative and Automated Driving (the standard that defines the SDCSM message type) and be enrolled in the FDOT SCMS using the latest PSID profile (i.e., the “FDOT RSU w/SDSM” profile).

For detailed descriptions of SCMS and IEEE 1609.2 please refer to the following references:

SCMS for North America:

- Security Credential Management System (SCMS) Proof-of-Concept Implementation End-Entity (EE) Requirements and Specifications Supporting [SCMS Software Release 1.2.1](#)^{xx}
- Technical Design of the Security Credential Management System - [Final Report](#)^{xxi}

IEEE 1609.2:

- 1609.2b-2019 - IEEE Standard for Wireless Access in Vehicular Environments--Security Services for Applications and Management Messages - [Amendment 2--PDU Functional Types and Encryption Key Management](#)^{xxii}

SCMS policy and administration is provided by SCMS Manager:

- The [Security Policy Authority](#) for the Vehicle-to-Everything (V2X) and Electric Vehicle-to-Grid (V2G) Ecosystems^{xxiii}

Other Related References:

- Connected Vehicle Deployment Technical Assistance: Security Credential Management System (SCMS) [Technical Primer](#)^{xxiv}
- [Security Credential Management System Proof of Concept](#)^{xxv}
- National Security Credential Management System (SCMS) Deployment Support: [SCMS Baseline Summary Report](#)^{xxvi}

5.2.5 DEPOT Requirements and Processes

Vehicle-to-Everything Data Exchange Platform (DEPOT) data ingestion and integration is typically a responsibility of the Contractor, FDOT RTMC IT Staff, or Systems Manager.

The DEPOT collects a variety of data from across the state of Florida, and the Districts and partners (Infrastructure Owner Operators such as Local Agencies, and Original Equipment Manufacturer (OEM)/ vehicle manufactures, and other technology companies) particular to CV data.

The CV projects will need to include the following as minimum requirements in the procurement documents.

- Devices will need to support forwarding CV messages to more than one destination/IP.
- If the RSUs does not support multi-cast, the device provider needs to provide a system to support CV field data routing:

- Software (and dedicated hardware if necessary) to support aggregation of messages received from field devices (RSUs) which will then be sent to one or more target destination IP/port (UDP) combinations. The software/hardware should support multiple-input/multiple-output configurations, i.e., messages received with a specified PSID may be sent to multiple destination targets; multiple messages received with different PSIDs may be sent to the same destination target. Message forwarding should occur in near-real-time. No long-term storage of messages is necessary.
- Aggregation software should include configurable options to include the mac address of the source RSU ethernet port, IEEE 1609.3 frame, IEEE 1609.2 frame, and the SAE J2735 message payload in each message.
- Configure all equipment and the aggregation system to forward CV messages to the DEPOT and support integration testing with the DEPOT project team. A few examples of how this can be accomplished:
 - A District hosted VM with the aggregation system installed on it.
 - Forwarding all messages to a singular message handler at the district level and forwarded to the District desired endpoints.

5.2.6 RSU HMS Requirements and Processes (This portion will be retired in December 2025, please ask the respective District TSM&O Engineer on utilizing SunGuide for RSU-HMS)

RSU HMS integration is typically a responsibility of the Contractor, FDOT's RTMC IT Staff, or Systems Manager.

Roadside Unit Health Monitoring Systems or RSU HMS [[Hyperlink](#)]^{xxvii} uses SNMP queries to request health status information from individual RSUs. The system has been designed to operate using a variety of SNMP Object Identifier (OIDs) defined in CV standards, most notably the OIDs defined in the legacy USDOT RSU4.1 Specification, NTCIP 1218, and some other common OIDs that are often supported by a variety of network devices (e.g., Device Time, 1.3.6.1.2.1.25.1.2.0), use SNMP queries to request health status information from individual RSUs. The system has been designed to operate using a variety of SNMP OIDs defined in CV standards, most notably the OIDs defined in the legacy USDOT RSU4.1 Specification, NTCIP 1218, and some other common OIDs that are often supported by a variety of network devices (e.g., Device Time, 1.3.6.1.2.1.25.1.2.0).

For RSUs to respond to queries from the RSU HMS, they must be configured with a SNMPv3 User (read-only access). See section 6.1.1 for additional details concerning configuration of devices and technical information on configuration and integration of RSUs with the FDOT statewide RSU HMS.

5.2.7 Managing and Tracking Device Information

Managing and tracking the device information is the responsibility of the Contractor, FDOT's RTMC IT Staff, or Systems Manager. Regardless of project type, managing and tracking device information is key to project success. A living document should be maintained which tracks details of project equipment including location (Lat/Lon), make, model, serial number, network configuration settings, login credentials, and other pertinent information. Past ITS projects, including projects that include CV equipment, have used various spreadsheets to capture information in a concise and simple format that can be shared with project team members on a need-to-know basis.

This is extremely critical for the Systems Manager project where there is an exchange of devices between the Systems Manager, owner agency, and the contractor. When devices change hands, it is important to

utilize a letter of transmittal (LOT) for each occurrence as well as a manifest of devices (e.g., a list of each individual devices with identifying information such as serial numbers, make and model of each unit). Additionally, it is important to track the deployment status of each device. This means tracking the progress of the device from receiving the unit to final testing of each device.

5.3 Project Requirements, Testing, and Acceptance

FDOT has Developmental Specifications that establish the minimum requirements for CV RSE materials, installation, and testing. The Developmental Specifications should be incorporated into Contract Documents produced for FDOT projects that require RSE such as RSUs.

It is also recommended that non-FDOT projects executed by local agencies and other FDOT partners also adapt the content of FDOT minimum requirements whenever possible within their own contract documents as these requirements are based on national standards and have been vetted by FDOT. Additional information on FDOT Developmental Specifications can be found online [[Hyperlink](#)]: ^{xxviii}

5.3.1 Field Testing

Connected Vehicle Devices are often both Traffic Control Devices and ITS Devices. As such, the requirements in FDOT Standard Specifications for Road and Bridge Construction Section 611, Acceptance Procedures for Traffic Control Signal, Devices, and Intelligent Transportation System Devices apply. One difference between CV devices and other equipment is that FDOT has not yet developed and published standardized FDOT forms for CV device testing. FDOT forms are available and used for ITS Devices such as MFES, CCTV, MVDS, CLD, DMS, and RPMUs as described in 611-4.2. Since there are no official FDOT forms for CV equipment at present, CV devices must be evaluated based on project Contract Documents. Therefore, installation inspection and testing procedures will depend on agreed upon test plans that FDOT specifications typically require the Contractor to develop and submit.

The developmental specification for [CV Roadside Equipment](#) (Dev681 and Dev995)^{xxix} requires that the Contractor develop and submit a test plan for field acceptance tests to the Engineer for consideration and approval. In addition, the developmental specification includes field testing requirements that must be part of test plans submitted by the Contractor. Accepted plans must sufficiently demonstrate required project functionality. The Contractor, their subcontracted integrators and manufacturers usually develop the initial test plans and then Department technical staff, the engineer-of-record, Systems Manager or Construction, Engineering, Inspection (CEI), and in certain cases, local maintaining agencies review, comment, and provide input until the plan is accepted.

At minimum, field testing must confirm that:

- Physical construction has been completed as detailed in the Plans
- Wire and cable connections are correct and secure
- Power supplies and related power circuits provide correct power
- Power LEDs on roadside equipment is illuminated
- CV equipment user interface can be accessed onsite
- Configuration of CV equipment network interfaces is correct
- RSUs can communicate with the FDOT SCMS, downloaded security certificates are current, and security certificates are automatically topped-off
- RSU broadcasts to and from vehicles equipped with an OBU capable of message display

- MAP, SPAT, and TIM message broadcast are verified
- BSM receipt and forwarding by RSU is verified
- Local functionality of CV applications required by Contract Documents such as those below are verified
 - VRU or Vulnerable Road User warning functionality
 - Red light violation warning functionality
 - Preemption and priority functionality

5.3.2 System Testing

Like field testing, System Acceptance Testing of CV equipment is usually considered part of ITS System Acceptance Testing and should meet or exceed the minimum requirements in the FDOT Standard Specifications for Road and Bridge Construction, Section 611-5 ITS Systems Acceptance Test.

System testing should address:

- General requirements associated with device operation and reliability during the burn-in period.
- Network Connectivity Test (End-to-End, Internet Control Message Protocol (ICMP) ping test)
- Integration of devices into other systems such as SunGuide, FDOT V2C DEP, FDOT and other systems based on Contract Document requirements.
- The RSU data can be seen by central cloud systems, including but not limited to, vendor's central system, SunGuide, RSU HMS, and DEPOT.

5.4 As-built Information and Documentation

CV roadside equipment (RSE), including RSUs, are considered traffic control devices by FDOT. As such, as-built submittals must include horizontal position geographic coordinate data collected using Differential Global Positioning System (DGPS) equipment as well as the manufacturer, model, and serial number for each piece of equipment installed on a project. This information is required by Section 611, Acceptance Procedures for Traffic Control Signals, Devices, and Intelligent Transportation Devices in the FDOT Standard Specifications for Road and Bridge Construction.

5.4.1 ITSFM Asset Form

The Department has created an ITS Facility Management System (ITSFM) attribute form for collecting RSU site information. The [form is available online](#)^{xxx}.

^{xii} Commodities and Contractual Services - Procurement Manual - 375-040-020: <https://www.fdot.gov/procurement/ccspm.shtm>

^{xiii} FDOT Procurement Home: <https://www.fdot.gov/procurement/default.shtm>

^{xiv} Central Office ITS Communications Administrator: <https://www.fdot.gov/traffic/its/telecom.shtm> (850)410-5600 or email: ITS-Communications-Administrator@dot.state.fl.us

^{xv} ULS License - Intelligent Transportation Service (Public Safety) License - WQBS407 - Florida, State of (fcc.gov). <https://wireless2.fcc.gov/UlsApp/UlsSearch/license.jsp?licKey=2676154>

^{xvi} District Five Connected Vehicle Configuration Plan for Standardization V2, October 15, 2024

https://www.cflsmartroads.com/projects/design/docs/FDOT_District_Five-CV_Config_Standardization_Plan_v2.0.pdf

-
- ^{xvii} USDOT Tool Library Using SAE J2735 (ISD Message Creator for MAP and SPaT, TIM Message Creator, Message Validator) <https://webapp.connectedvcs.com/> (2019 version) and <https://webappopen.connectedvcs.com/> (2024 version)
- ^{xviii} Connected Vehicle Pooled Fund Study hosted through the University of Virginia. <https://engineering.virginia.edu/labs-groups/cvpfs>
- ^{xix} Guidance Document for MAP Message Preparation: [https://engineering.virginia.edu/sites/default/files/Connected-Vehicle-PFS/Projects/\(MAP\)%20Guidance/Map%20Guidance%20Document%20-%20Revision%204%20FINAL%20v2.pdf](https://engineering.virginia.edu/sites/default/files/Connected-Vehicle-PFS/Projects/(MAP)%20Guidance/Map%20Guidance%20Document%20-%20Revision%204%20FINAL%20v2.pdf)
- ^{xx} Security Credential Management System (SCMS) Proof-of-Concept Implementation End-Entity (EE) Requirements and Specifications Supporting SCMS Software Release 1.2.1: https://its.dot.gov/research_areas/cybersecurity/scms/index.html
- ^{xxi} Technical Design of the Security Credential Management System - Final Report: <https://www.regulations.gov/document/NHTSA-2015-0060-0004>
- ^{xxii} 1609.2b-2019 - IEEE Standard for Wireless Access in Vehicular Environments--Security Services for Applications and Management Messages - Amendment 2--PDU Functional Types and Encryption Key Management: <https://ieeexplore.ieee.org/document/8734860>
- ^{xxiii} The Security Policy Authority for the Vehicle-to-Everything (V2X) and Electric Vehicle-to-Grid (V2G) Ecosystems: <https://www.scmsmanager.org/>
- ^{xxiv} Connected Vehicle Deployment Technical Assistance: Security Credential Management System (SCMS) Technical Primer: <https://rosap.ntl.bts.gov/view/dot/43635>
- ^{xxv} Security Credential Management System Proof of Concept: <https://www.its.dot.gov/resources/scms.htm>
- ^{xxvi} National Security Credential Management System (SCMS) Deployment Support: SCMS Baseline Summary Report: <https://rosap.ntl.bts.gov/view/dot/36397>
- ^{xxviii} FDOT Developmental Specifications <https://www.fdot.gov/programmanagement/otherfdotlinks/developmental/default.shtm>
- ^{xxix} **Dev681CVRSE** and **Dev995CVRSE** - Connected Vehicle Roadside Equipment and Connected Vehicle Roadside Equipment Materials can be found at: <https://www.fdot.gov/specifications/developmental-specifications>
- ^{xxx} ITSFM RSU Attribute form: https://fdotwww.blob.core.windows.net/sitefinity/docs/default-source/traffic/itsfm/documents/datacollection/2022/itsfm062-roadside-unit-form.pdf?sfvrsn=2d391e01_2

Section 6: Operations and Maintenance Considerations

CV RSUs and edge computing devices are usually installed as additional equipment at new or existing intersections and ITS locations to enhance and supplement the function of other traffic control devices. As with any new equipment introduced into a traffic control system, these devices will require some degree of additional effort to operate and maintain. While RSUs and edge computing equipment should be relatively low maintenance following proper installation and configuration, they must still be periodically monitored and maintained to ensure that they continue working properly.

Maintaining agencies must incorporate the operation and maintenance (O&M) of CV equipment as part of their standard O&M practices for the overall traffic control system. This section shares information on best practices, lessons learned, common activities, and helpful tools for the general operation and maintenance of CV equipment and systems.

6.1 Operational Software

There is a variety of operational software that must be considered when planning, deploying, operating, and maintaining CV equipment. This includes vendor-agnostic software developed or customized for FDOT statewide use (e.g., SunGuide®, DEPOT) as well as software provided by CV equipment manufacturers that is specifically designed for use with the field hardware that they produce.

Vendor-specific central software systems designed to complement CV product offerings by offering varying degrees of central monitoring and control from different manufacturers include Commsignia Central by Commsignia, VantageARGUS CV from Iteris, Connected Mobility Control Center (CMCC) from Kapsch, and Cooperative Management System software from Yunex Traffic.

6.1.1 FDOT Statewide Software (SunGuide, SCMS, DEPOT)

FDOT Statewide software systems related to the overall FDOT CAV program include:

- **FDOT SunGuide® software** –the Connected Vehicle Subsystem (CVS) was included in SunGuide 5.1.0 and first released in 2009. The subsystem was designed and implemented around two primary functions:
 1. It allows TIM messages to be sent to RSUs, either directly or via an automatic response plan.
 2. It reads BSMs collected by RSUs and uses these to calculate average speed at the RSUs. These speeds can then be used for generating travel time.

Recent updates:

- Support for the 2016 version of J2735; probably needs a refresh soon.
- Added the TIM Message Library to support I-75 FRAME.
- Added tagging with application category to support before/after studies.

Planned updates:

- GUI updates (e.g., rename TAM to TIM)
- Add SAE codes to TIM messages to line up with industry (OBU vendor) needs.
- Enhance status monitoring of RSUs.
- Add TIM data to C2C so that they can be shared with FL511.

Comprehensive information on SunGuide software and its CV capabilities is available online [\[Hyperlink\]](#)^{xxxi}

SunGuide could be leveraged in CAV projects during operation and maintenance in the following manner:

- SunGuide integration of the RSUs should be completed during the construction and be part of the acceptance test plan.
- TAM option within the Response Plan Generator should be used for broadcasting TIMs via RSUs.
- When the RSU health status enhancement is available, use the enhancement option to track health status of the RSUs and create maintenance tickets as needed.
- **FDOT SCMS Certificate Management System (CMS)** – The CMS is a web-based software component of the Department’s CV Security Credential Management System (SCMS). The CMS enables authorized users to enroll CV devices (e.g., RSUs and OBU) as part of FDOT’s CV infrastructure and provision the devices to automatically request and receive security certificates necessary to establish trust between devices that are part of FDOT’s SCMS ecosystem. The enrollment and provisioning process is required to be performed by CV equipment manufacturers in coordination with FDOT Central Office Connected and Automated Vehicle (FDOT CAV) staff. The portal for the FDOT SCMS Web User Interface is available online after obtaining credentials from TEO CMTP.

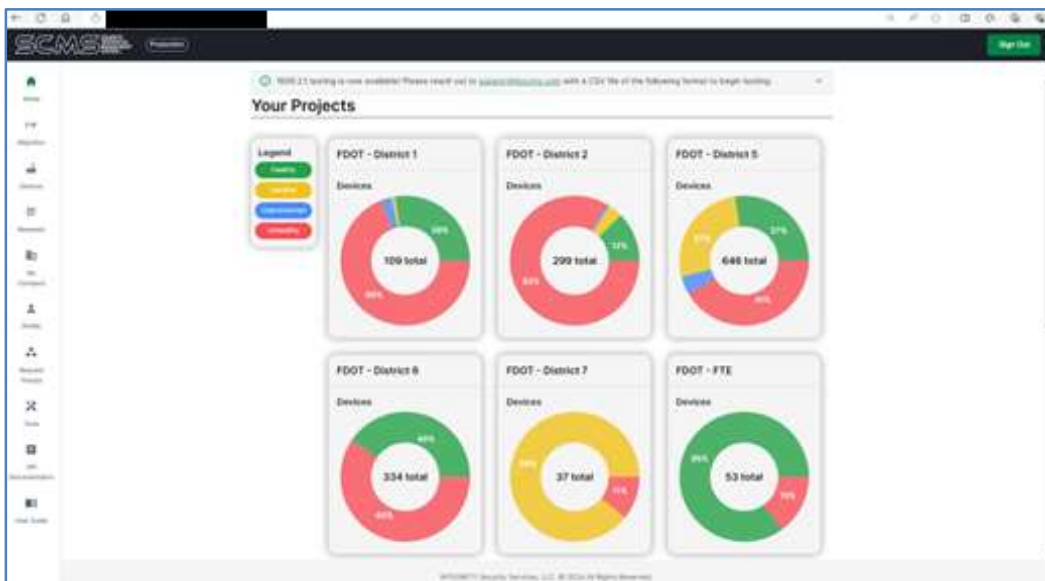

Figure 6-1: Home Page of FDOT SCMS

Comprehensive information on the principles of operation and use of the SCMS, including its REST API and Web User Interface, is provided in a User Guide that is included on the portal and made available to authorized users.

It is important to note that RSUs must be able to communicate with the CMS to automatically request and receive security certificate “top-offs” during operation. Typically, RSUs are enrolled and provisioned in the system in a manner that results in them receiving and storing an initial set of two certificate files sufficient for two weeks of operation. Upon the expiration of the oldest of the certificate files stored on the RSU (usually each week), the RSU will request a certificate top-off from the CMS. If successful, the expired file

will be automatically deleted from the RSU and a new file will be stored on the RSU with a filename indicating an expiration date two weeks in the future. Methods for accessing RSUs directly to check for certificate top-offs varies but this information is usually available via the RSU's graphical user interface (GUI) . Consult the RSU's user manual for device-specific instructions.

The SCMS device management portal could be used in the following manner during the operation phase of the CAV project:

- Verify the devices were able to top-off certificates properly which indicates devices are properly connected and in a healthy status.
 - If a device has not topped off with valid certificates that can be an indicator of some connectivity issue to the TMC and to the SCMS server via secured internet connection.
- **NOTE: RSU-HMS is being retired on December 2025. This portion is kept for historical insight, FDOT RSU Health Monitoring System (RSU-HMS)** – The RSU-HMS enables authorized users to monitor real-time health and status of RSUs deployed within Florida and provides reporting features associated with RSU operation. The system monitors and reports information such as RSU security certificate status, general RSU operational status, and other information. It is also capable of providing automated alerts and various device health analytics. The portal for the FDOT RSU HMS Web User Interface is available online after obtaining credentials TEO CMTP.

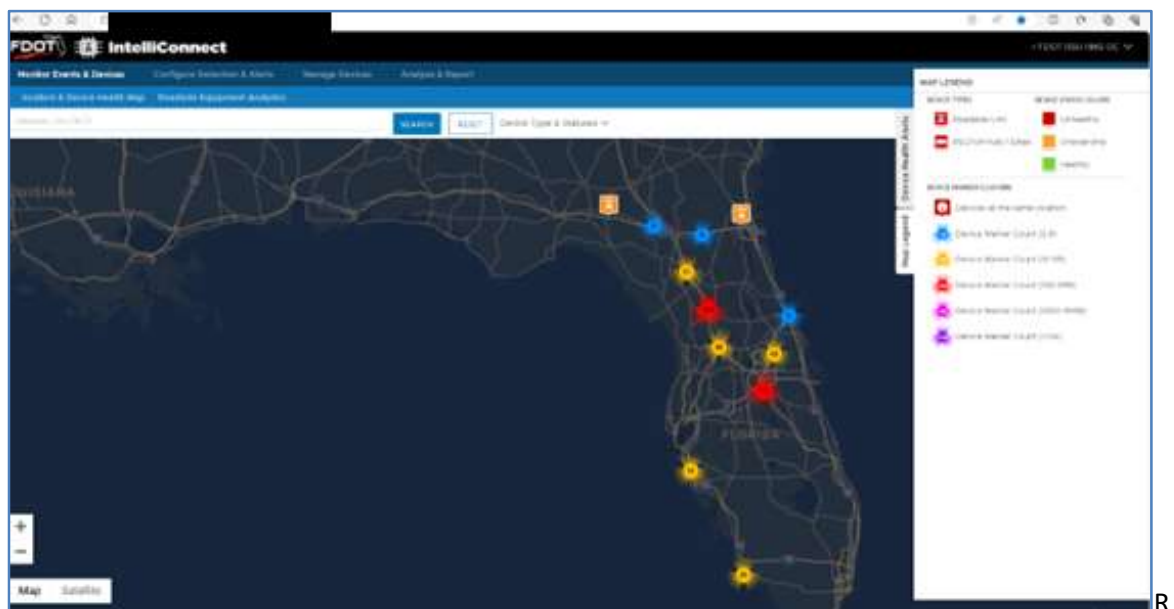

Figure 6-2: Home Page of FDOT RSU Health Monitoring System

The RSU HMS uses simple network management protocol version 3 (SNMPv3) to query field devices and retrieve operational status information. Therefore, RSUs must be configured with an SNMPv3 user and password for secure data exchange with the RSU HMS. The system uses a variety of SNMPv3 objects that are defined in multiple standards, including SNMP objects defined in NTCIP 1218 and legacy USDOT RSU 4.1 requirements. Methods for configuring RSUs with SNMPv3 users varies but is often done via the RSU's

graphical user interface (GUI) Consult the RSU manufacturer or RSU user manual for detailed device-specific instructions.

Close coordination between FDOT Districts and local agency partners is essential to establish and maintain secure network connections that allow field devices on local agency traffic networks to communicate with equipment and systems on the FDOT District ITS network and the FION. Establishing network connectivity between field devices and central systems such as the RSU HMS requires significant work and cooperation between network administrators, system developers, device manufacturers, and others. Work includes general coordination, firewall and router configuration, field device configuration, and initial connectivity testing, followed by ongoing network monitoring, maintenance, and troubleshooting.

- FDOT Vehicle-to-Everything Data Exchange Platform (DEPOT)** – The DEPOT collects and stores data generated from FDOT’s Connected and Autonomous Vehicle (CAV) deployments across the state, enabling FDOT to consolidate data from numerous disparate transportation systems and projects.

The DEPOT will eventually collect, store, and provide analytics on a wide range of data from CAV deployments and other systems, including FDOT’s SunGuide software, Data Integration and Video Aggregation System (DIVAS), SunStore, and the Florida Advanced Traveler Information System. Data from various 3rd-party systems will also be consumed and used, including data from vehicle OEMs, weather systems, and 3rd-party traffic data providers such as HERE Technologies and Waze.

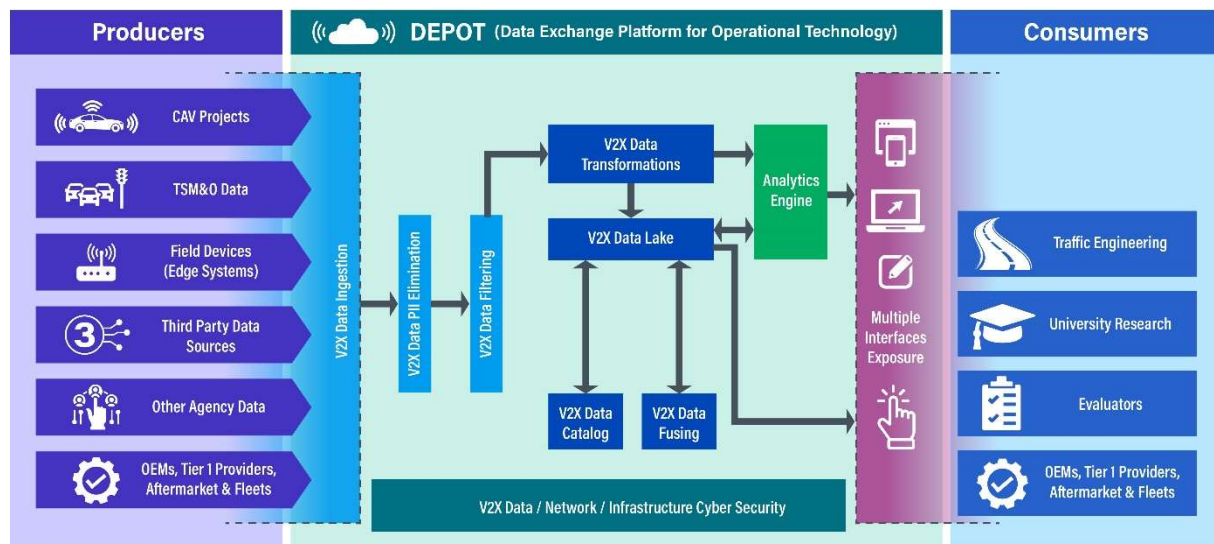

Figure 6-3: DEPOT (formerly V2X DEP) High-level System Architecture

The system is being implemented using a phased development and deployment approach. Districts and Local Agencies deploying RSUs will be requested to configure their RSUs to provide a real-time data feed of all messages that are broadcast and received by the device to the DEPOT. For example, MAP, SPAT, BSM, and other messages defined in SAE International CV Standards (e.g., SAE J2735, J2945).

The DEPOT requires that RSUs communicate with a “DEPOT Forwarder” software service that is hosted in each FDOT District. The DEPOT Forwarder and the District ITS network must be configured so that RSUs within the District (including RSUs on local maintaining agency networks) can send data streams to the

DEPOT Forwarder service and the service can subsequently pass that data to DEPOT web services hosted on the Internet via the Florida ITS Operations Network (FION). In the future, as local agencies deploy and maintain additional RSUs on their own networks, it is anticipated that this general system architecture may be expanded such that a forwarder on the local agency network aggregates data from local field devices and forwards to an aggregator/forwarder on the District network that, in turn, forwards data to the DEPOT via the FION.

Close coordination between FDOT Districts and local agency partners is essential to establish and maintain secure network connections that allow field devices on local agency traffic networks to communicate with equipment and systems on the FDOT District ITS network and the FION. Establishing network connectivity between field devices and central systems such as the DEPOT requires significant work and cooperation between network administrators, system developers, device manufacturers, and others. Work includes general coordination, firewall and router configuration, field device configuration, and initial connectivity testing, followed by ongoing network monitoring, maintenance, and troubleshooting.

Methods for configuring RSUs to send data streams to third party systems varies but is often done via the RSU's graphical user interface (GUI). Consult the RSU manufacturer or RSU user manual for detailed device-specific instructions.

6.1.2 Vendor-specific Software Systems

Vendor-specific software systems designed to complement CV product offerings from different RSU manufacturers include:

- Glance Smart City Supervisory System from Applied Information
- Commsignia Central from Commsignia
- VantageARGUS CV from Iteris
- Connected Mobility Control Center (CMCC) from Kapsch
- Cooperative Management System software from Yunex Traffic.

Vendor-specific software is not always required for fundamental operation of RSUs but often provides features and benefits that are helpful for system configuration, operation, and maintenance. Pricing structures for initial software acquisition and ongoing maintenance and technical support can vary greatly. Software costs are also highly variable and negotiable. Prior to procurement of RSUs, request that the manufacturer provide comprehensive technical and pricing information on their companion software systems as this should factor into field hardware acquisition decisions.

Some vendor software is designed for on-premises operation, and some is designed exclusively as a cloud-based solution that is hosted on the Internet and maintained by the RSU manufacturer. Cloud-based solutions generally leverage the fact that RSUs require Internet connectivity for other operations, such as communication with the SCMS. These systems are usually limited to operation and monitoring of RSUs from a single vendor. However, they are valuable tools that are recommended for use in addition to vendor agnostic FDOT software systems such as SunGuide software and the SCMS, RSU HMS, and DEPOT. Vendor-specific software systems provide additional features and insights into RSU operation that are not available using FDOT software systems alone.

6.1.3 General User Account recommendations

CV practitioners must consider user account needs for system administrators, maintainers, and operators as part of their overall CV program. Central software and field devices are typically secured with password-protected user accounts that can have different permission levels. In addition to having accounts for human users, systems and devices often also require accounts to be used by software services (e.g., SNMP user account for automatic RSU status monitoring by the RSU HMS).

As with other information technology systems and equipment, system administrators must be provided administrative accounts that have the highest level of privilege available and be responsible for creating other user accounts. Maintainers will typically need administrative or elevated privileges with read/write access for field device troubleshooting, repair, and replacement. Operator accounts should be granted the lowest level of privilege necessary to perform their tasks (e.g., a read-only SNMP user account for use by monitoring systems such as the RSU HMS). User accounts and login credentials for devices and systems should be assigned and managed in accordance with local policy regarding security of traffic control devices and be done in a manner appropriate for securing this infrastructure equipment and preventing unauthorized access and malicious activity.

6.1.4 Licensing

Ongoing operation and maintenance costs of software must be considered in addition to initial capital costs for acquisition. During initial purchase, manufacturers may offer CV equipment and systems with limited basic functionality and subsequently require the purchase of additional software upgrades or license keys to add or unlock additional features and functions they consider “options” or “enhancements.” Even when roadside equipment is initially provided with all available features, it is usually recommended to consider potential licensing that may require ongoing technical support, software/firmware updates, enhancements (e.g., development of additional applications), and subscription services from CV manufacturers and system developers. FDOT Districts are advised to consult FDOT’s RSU Developmental Specification (DevSpec) for any updated licensing requirements to be met by the RSU vendors and should add those minimum requirements for ongoing licensing in the contract.

6.2 Preventive Maintenance and Troubleshooting

RSUs and other roadside equipment must be periodically checked and maintained like any other traffic control devices. Verifying proper operation of CV equipment should be added to typical preventive maintenance activities and checklists that are associated with maintenance of traditional traffic control devices at signalized intersections and ITS field sites.

6.2.1 Centralized Operational Monitoring and Checks

The use of the FDOT RSU HMS is highly recommended for all RSUs deployed in Florida, including RSUs deployed by local agencies as well as FDOT. In addition, a network monitoring system should be used to automatically check for device connectivity and provide an alert if connectivity is lost. Systems commonly used include the FDOT RSU HMS, Paessler Router Traffic Grapher (PRTG) Network Monitor, SolarWinds, What’s Up Gold, and other similar tools. It is recommended that network administrators responsible for operation of the local traffic system network incorporate monitoring of RSU connectivity within their respective network management systems (NMS). At minimum, the NMS should monitor basic connectivity with the RSU (e.g., fundamental Ethernet connectivity uptime) and be configured to provide alerts as appropriate when field devices unexpectedly go offline. Reporting features of NMS vary, but typically support reporting features to track device uptime and help troubleshoot fundamental connectivity issues.

Authorized staff should also perform periodic spot checks of operation to verify general functionality by remotely logging into devices or using supplemental monitoring applications provided by RSU manufacturers.

6.2.1.1 Local and Remote Spot Checks

Periodic operational spot checks are recommended in addition to automated monitoring, alarms, and scheduled preventive maintenance activities. Spot checks should include a mix of remote operational checks using network access to roadside equipment and onsite drive testing using an OBU to confirm that RSUs are broadcasting properly, and end-to-end system operation is working as required.

In addition to operational spot checks of RSUs, OBU spot checks are important for ensuring the security and functionality of CV systems. OBUs should be periodically checked to generally confirm proper operation, including that they are receiving SCMS security certificate top-offs, that hardware connections are tight and secure, and that the device has data connectivity but is not limited to these functions. It is also advisable to regularly check the status of applications on the unit. Coordination with Fleet managers is essential to incorporate OBU checks as part of regularly scheduled vehicle maintenance activities. Fleet managers and technicians can be utilized to check that hardware associated with OBU systems is in good physical condition and general working order. Agencies should ask their specific OBU vendors for recommendations based on the specific products that they provide.

The FDOT SCMS portal provides a centralized way to monitor SCMS security certificate top-offs for end entities in the FDOT CV ecosystem (e.g., RSUs and OBUs). It allows authorized users to track CV devices individually via a GUI which can also be used to organize, tag, block, and enroll devices. Additionally, creating a local server can also help capture additional logs, providing greater detail in case of an issue.

Some agencies have opted to provide network connectivity to OBUs in fleet vehicles using a SIM card on an Access Point Name (APN), effectively placing the OBU onto their secured network. This allows the OBU to be remotely accessed, monitored, and managed by authorized system administrators and enables remote troubleshooting. Secure remote connectivity to OBUs, whether via APN or other means, are beneficial to operations and maintenance by giving system administrators the ability to remotely check that various CV application software services are active and operational and troubleshoot issues without needing physical access to the OBUs.



Figure 6-4: ISS Portal showing an OBU device status and tags

6.2.1.2 Onsite Drive Tests

Multiple projects have utilized a variety of OBUs and applications as part of system acceptance testing and subsequent operation and maintenance. On many past projects, OBUs that were provided to perform a minimum set of specific project applications were used to verify overall system operation. These “driver-focused” demonstration devices were often restricted to presenting drivers and test personnel with limited audible and visual alerts and information based on project-specific needs and requirements. The primary goal of these aftermarket demonstration devices is often to demonstrate what OBUs integrated in future production vehicles may provide in terms of user experience. In cases where these devices also provide additional diagnostic information, that information is typically limited and not available in a

comprehensive, user-friendly interface. Technicians must often rely on terminal sessions to the device using a laptop and issuing device-specific commands to retrieve text-based responses that require subsequent processing and decoding to interpret.

Based on experience, it is recommended that system operators and maintainers invest in portable OBU systems that can be easily and temporarily installed in a host vehicle (and be transferred between vehicles as needed). In addition, these portable OBU systems should include both a driver-focused demonstration GUI and a user-friendly diagnostic application that provides full insight into the message traffic and information that the OBU receives. If multiple vehicles are available with different PSID, conduct a drive test with at least one of each vehicle type (e.g., regular passenger/fleet types, vehicles with some level of priority, etc.).

Within the last year, at least one CV vendor (Iteris) has started offering OBU systems that include all components needed to easily assemble a portable OBU that can view and store comprehensive information on RSU-OBU data exchange for testing, maintenance, and troubleshooting purposes. The key component in this system is an application named V2X Connect that runs on an Android Tablet. When this tablet application is connected to the OBU via Wi-Fi, it can receive, decode, and display information contained in a data stream that is provided by the OBU. This data stream generally includes all the SAE J2735 message traffic being transmitted and received by the OBU radio. The application has proven to be a useful tool when confirming data exchange between the OBU and RSUs (e.g., proper message format and content) and has been used regularly on projects in FDOT District 2 and District 5 to support verification of RSU operation. The tablet application currently supports connection and use with Commsignia and Denso OBUs with the required wireless connection and proper credentials. In addition, the V2X Connect application can be used in parallel with driver focused demonstration GUIs provided by others. Districts should be mindful of the cost that can be incurred by performing the drive tests along the corridors. Since the Central Office is not proposing a minimum number of drive tests yet, it is recommended that the Districts adopt a frequency suitable for the project goals and objectives.

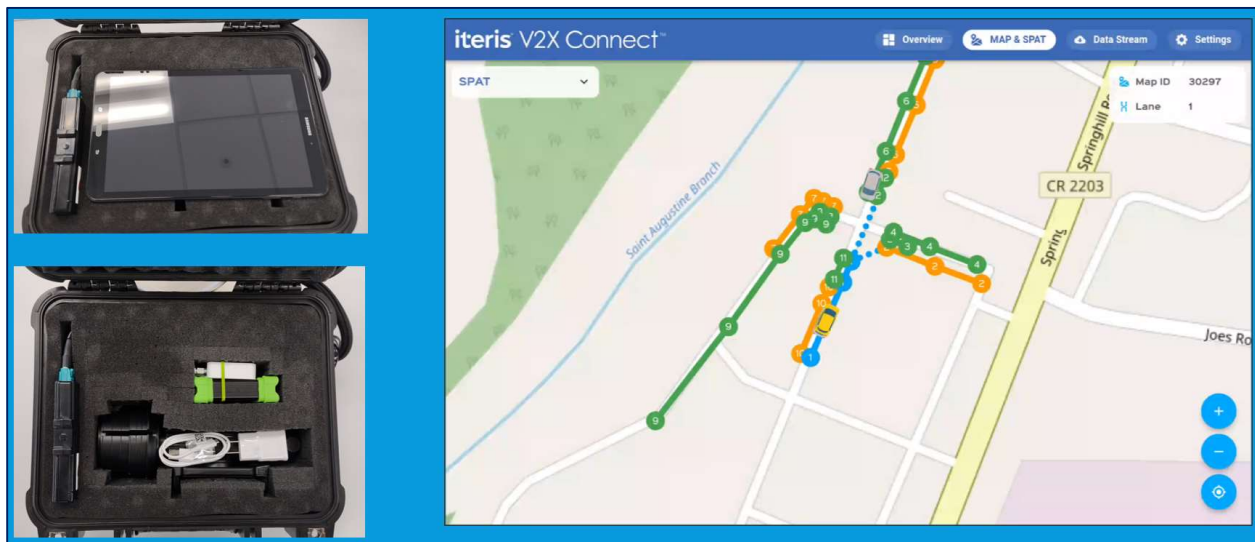

Figure 6-5: Portable OBU with Wi-Fi adapter and Realtime Diagnostic Application on Android Tablet

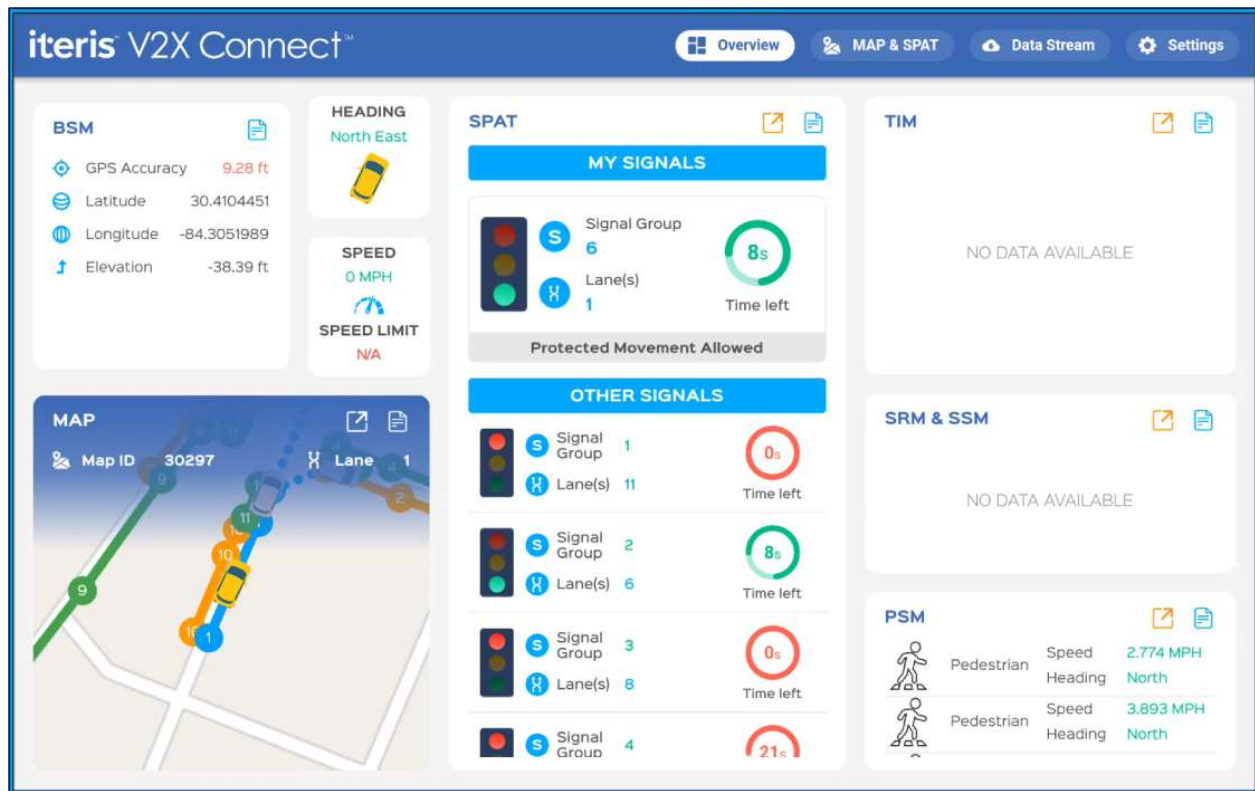

Figure 6-6: Overview Data using Realtime Diagnostic Application on Android Tablet

6.2.2 Useful Tools

In addition to the use of a centralized NMS for automated field device monitoring and OBU diagnostic applications such as V2X Connect, there are several other useful tools and applications that are typically needed for CV device configuration, periodic monitoring, and troubleshooting. These include SNMP walk tools, WireShark, WinSCP (Secure Copy Protocol), Putty, and others that are often familiar to network administrators and technicians.

6.2.2.1 Unrestricted Web Browser

FDOT requires that RSUs support web-based user access through a GUI that provides secure access for device configuration, operation, and maintenance. Many RSUs provide this interface through password protected web-based administration (i.e., “webmin”) webpages that are hosted on the device and use secure hypertext transfer protocol (https://). Webpages hosted on RSUs generally use self-signed certificates by default. Many organizations apply restrictions on web browsers that are managed by the organization. These administrative restrictions often prevent users from being able to access a site that uses self-signed certificates. Therefore, it is important that authorized personnel who require direct access to RSU webmin pages have a browser that allows them to access pages with self-signed certificates that may otherwise be blocked by administrative controls due to appearing “unsafe.”

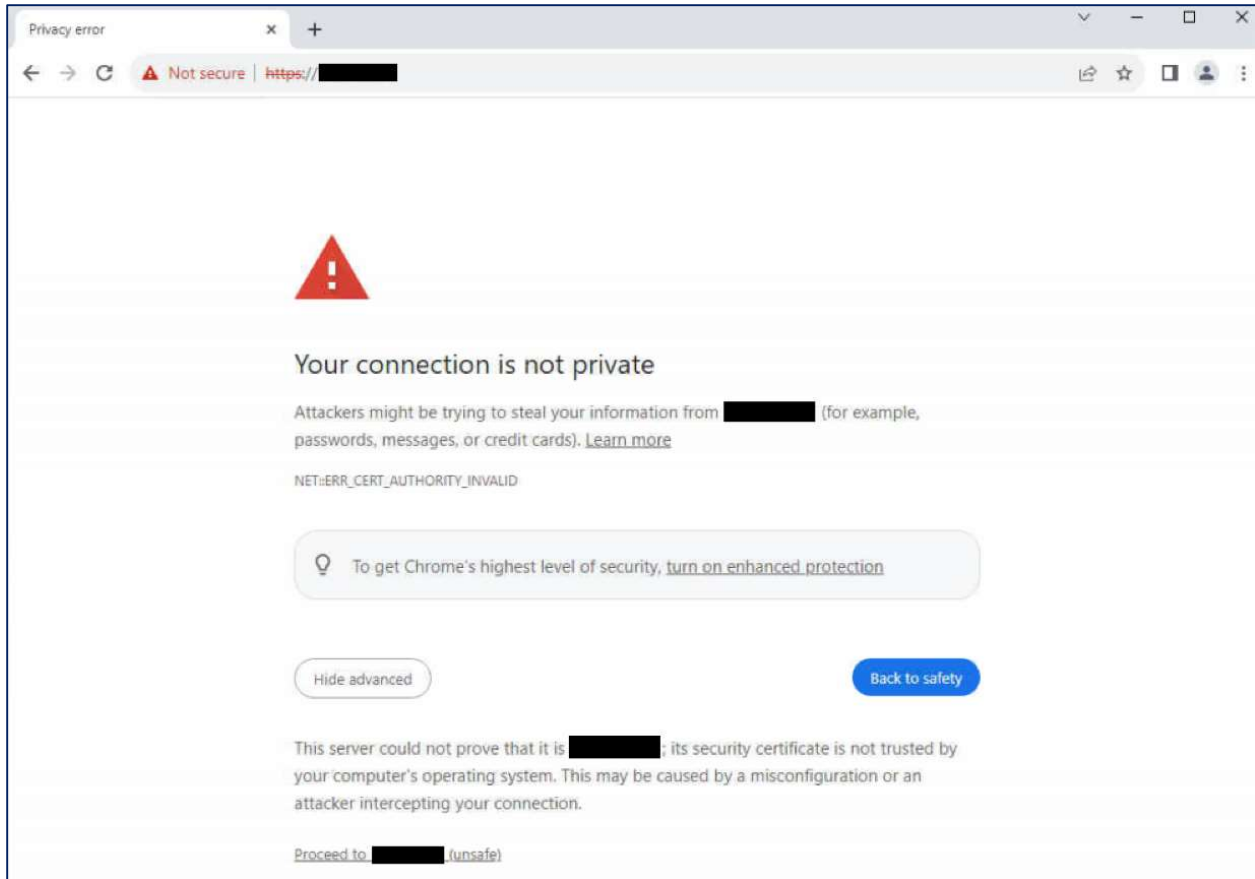

Figure 6-7: Example of “Unsafe Site” Warning during RSU Webmin Page Access

Some organizations may apply restrictions on web browsers that do not provide users with the option to proceed to the “unsafe” site, thus preventing access to the RSU. For this reason, authorized personnel must have a computer that includes a web browser that is exempt from organizational restrictions regarding access to websites using self-signed certificates.

6.2.2.2 Terminal Program Applications

It is beneficial for RSU maintainers to be familiar with the use of terminal programs. Terminal program applications are sometimes required to communicate with RSUs that are unable to be reached via webmin pages (for example, if internal webserver functions have unexpectedly terminated). RSU access using secure shell (SSH) can allow maintainers to remotely reboot devices and perform other operations. RSUs utilize a Unix-based operating system and, therefore, support command line access that can be useful for system troubleshooting and repair. Commands can vary by manufacturer, but many are common and will be recognized by users familiar with use of the Unix-based Linux terminal and command line interface (CLI).

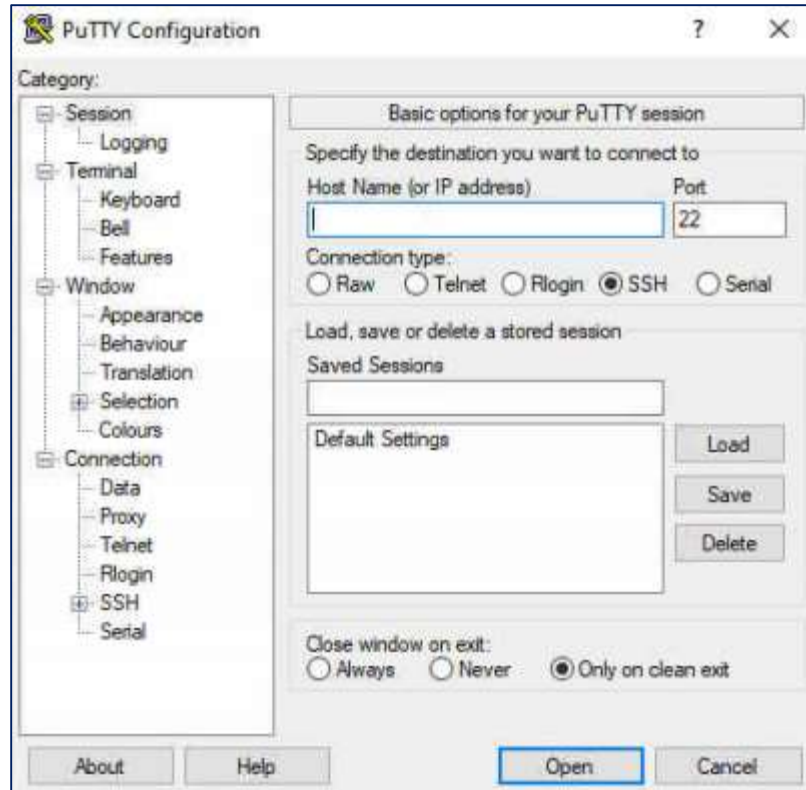

Figure 6-8: Example of Common Terminal Program that can be used for RSU CLI access.

```

login as: root
root@[redacted]'s password:
# ls
aerolink                processECResponse      v2xscppalutil.bin
cmsRestApiProcessor     rsu_generatekeys.sh
createECRequest         tcpBridge
io-pkt-v6-hc.core       tcpBridgeServerSide
# ifconfig
lo0: flags=8049<UP,LOOPBACK,RUNNING,MULTICAST> mtu 33192
    inet 127.0.0.1 netmask 0xff000000
    inet6 ::1 prefixlen 128
    inet6 fe80::1%lo0 prefixlen 64 scopeid 0x1
sc0: flags=8843<UP,BROADCAST,RUNNING,SIMPLEX,MULTICAST> mtu 1500
    address: fe:ff:ea:9a:17:3d
    media: Ethernet autoselect (100baseTX full-duplex,flowcontrol)
    status: active
    inet [redacted] netmask 0xfffff00 broadcast [redacted]
    inet6 fe80::fcff:eaff:fe9a:173d%sc0 prefixlen 64 scopeid 0x11
pflog0: flags=0 mtu 33192
#
  
```

Figure 6-9: Example of Terminal Session with RSU

6.2.2.3 File Transfer Applications

It is also beneficial for RSU maintainers to be familiar with the use of file transfer applications. File transfer programs are often useful to move files between a technician laptop and field device. File folder structures of RSUs usually vary by manufacturer, but some folder names are common or similar across different devices.

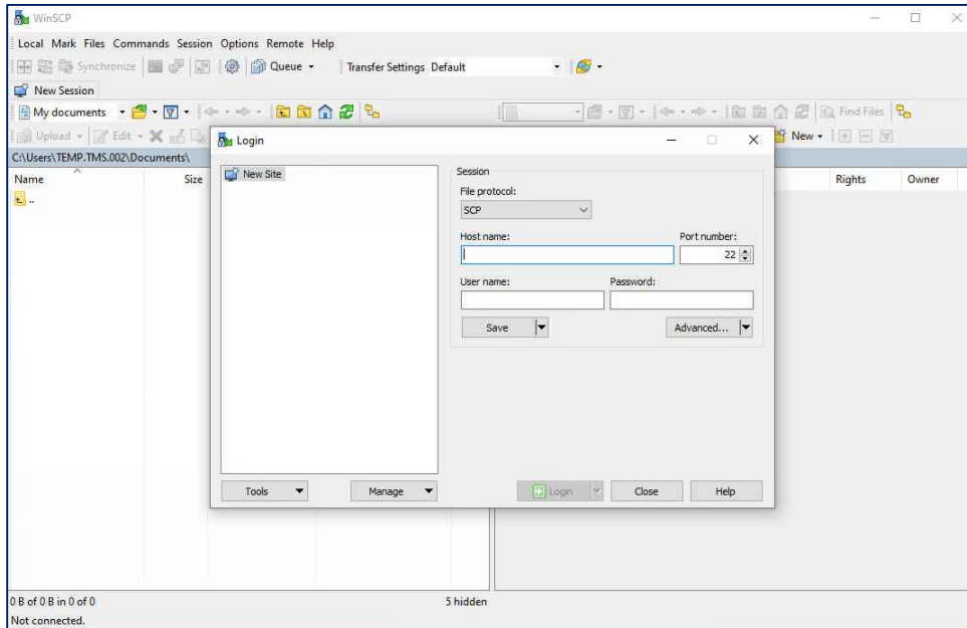

Figure 6-10: Example of Common File Transfer Program

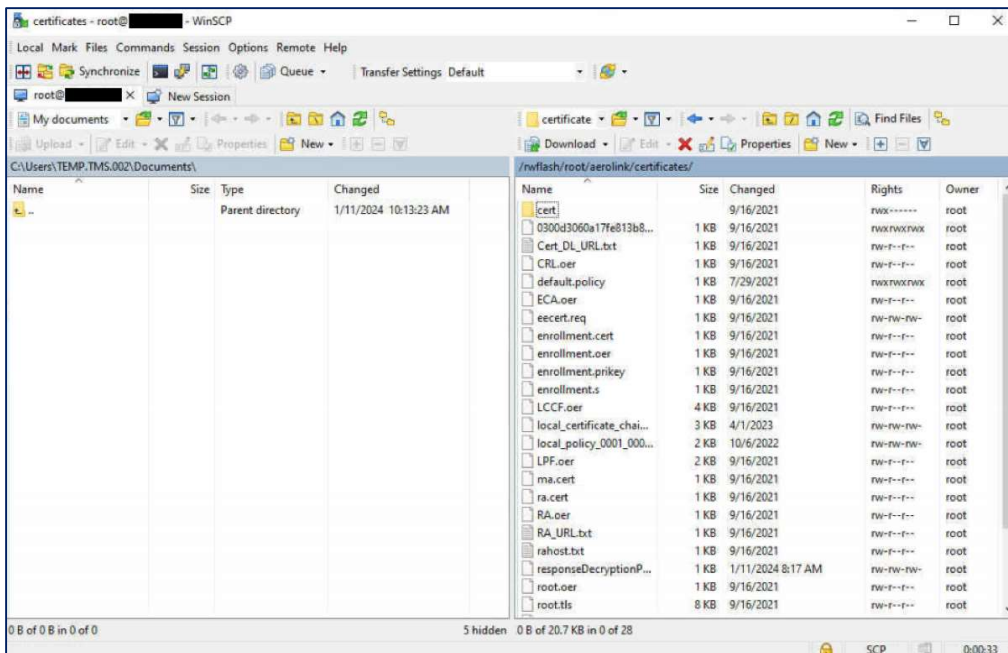

Figure 6-11: WinSCP session showing RSU aerolink/certificates folder related to SCMS

6.2.2.4 *Linux Computing Environment*

System administrators and technicians who are tasked with working on RSUs and other CV equipment should become familiar with the Linux computing environment if they are not already. Unix-based operating systems, predominantly variants of Linux, are commonly used by traffic control devices including modern traffic signal controllers and RSUs.

It is recommended that administrators, technicians, and other power users responsible for working on RSUs and other CV equipment have a Linux computing environment available for use on a laptop computer. A convenient way of providing this resource is for power users to install virtual machine software on their computer that allows subsequent installation and use of a Linux Ubuntu distribution and Linux-based applications and tools. This provides a full-featured Linux computing environment with tools and applications in addition to those available on the host machine (i.e., their business laptop which typically includes a Windows operating system).

^{xxxix} SunGuide Software - <http://www.sunguidesoftware.com/>

Appendix 1: Networking Lessons Learned and Best Practices

A.1.1 Configuration, Installation, and Integration

When considering project contract types, the agency must keep in mind the level of complexity of the project. CV projects are typically more technical in nature and will require personnel with a higher level of technical training and experience. For certain contract types (e.g., Systems Manager), the project team will be responsible for configuring and integrating the CV devices while the installation will be handled by the contractor, while for design-build or design-bid-build contracts, the contractors will be responsible for installation, configuration, and integration and the FDOT appointed CEI will ensure the accuracy of the contractors' performance.

- **Configuration Considerations:**
 - It is highly recommended that device configurations are conducted by someone with a background in IT or computer networks. Typically, the CV devices are Linux based units and require a specialized skillset to understand the configuration syntax.
 - This requires setting up the devices through either a command line interface or a GUI with training on each of the devices to properly configure the unit.
 - Working with the device vendor to troubleshoot any bugs or issues in the software, firmware, functionality, or features of the device. The issues are frequently new and require more time to work through them with the vendors technical support team.
 - Requires the users/technical team to quickly learn the operating systems of various new devices, set configuration parameters and understand their capabilities to configure the devices to meet the requirements of the project.
 - Requires the technical team to be familiar with FDOT's network architecture, business rules, interaction with local maintaining agencies and be familiar with the SunGuide and ATMS system.
 - The responsible party/technical team will have to configure the devices so the RSU or OBU can send data to the required endpoints specified in the contract scope. At a minimum, the endpoints are DEPOT, RSU HMS, and SunGuide.
 - A technical team will need to configure the devices being installed to be compatible with the agency's existing computer network.

- **Integration Considerations:**
 - The hardware vendor, System Manager and/or agency should establish a pre-integration meeting between all parties involved in network configuration and administration and form an "integration team" to discuss any concerns or potential issue months prior to the integration date.
 - The technical team/Systems Manager should have documentation of the existing network to assist with the integration process for the communications network.
 - The agency must consider the architecture of their network and the need for the new devices. For example, the RSUs will need to communicate with the signal controllers, however, if there is a firewall in between the RSU and signal controller, the firewall will need to be modified at all locations to allow communication between the units.

- The agency should also consider the interoperability between devices such as:
 - RSU to OBU – Ensure data can pass between the two units.
 - RSU to Signal Controller – Sometime firmware versions prevent communication between them. Verify with their respective manufacturer that the appropriate firmware version is installed on the devices.
 - RSU to Central Software – Ensure the software (i.e., SunGuide or Vendor Software) can communicate and reach the RSU from the TMC.
- The agency should consider the number of IP addresses required for each device. Some devices will require multiple IP addresses to be successfully integrated into the network.
- The Department should consider the following as minimum integration requirements and should include in the project scope:
 - Integrate RSUs into SunGuide’s CV sub-system
 - If FDOT Districts already has DEPOT (V2X DEP) forwarder installed on the ITS network, provide support with the device configuration to forward the specified messages to DEPOT
 - Enroll RSUs and OBUs into the statewide SCMS portal and ensure devices can top-off certificates as required

A.1.2.1 Secure Remote Access

Devices once behind an agency’s firewall and in the private network need to be verified, assuring SCMS top-off is occurring, communication with the ATMS is in place, and data is being transmitted to the DEP. To do this network access is needed and can be accomplished with experienced operations personnel but often involves vendors accessing the system remotely. If maintenance of infrastructure is expected, then remote access to determine health and to troubleshoot the device should also be expected. Minimal access privileges should be granted limiting the scope and scale of devices accessible by the vendor/contractor. Access granted should be shared with partner agencies if domain access from one agency is used to gain access to another. The best practice is to include the expectation of remote access throughout the project lifecycle.

- Device maintenance pay items should be included if the project is expected to involve maintaining the device, including signals.
- VPN access to be allowed following the process set forth by FDOT’s ITS IT Technical Assistance Group ([IT Policies and Statutes](#)).

A.1.2.2 Firewall Requirements, Miscellaneous Routing and Coordination

CV roadside equipment may have to be connected to different network subnets and domain structures and may require various firewall and cross domain rules (i.e., Network Address Translation, Gateway Static Routing, BGP/Border Gateway Protocol). Network engineers and administrators at each level (i.e., Local Agency Level, District Level, Central Office and FION levels) need to carefully coordinate with each other to achieve connectivity while using the principles of least privilege that limits user access to the minimum number of resources and permissions needed to perform their job.

Appendix 2: Forms, Checklists and Questionnaires

A2. Ch3.1 - Concept of Operations

Answering the following questions will help ensure required information is included in the ConOps document:

“WHO...”

- Who are the project stakeholders?
- Who will be responsible for the operations and maintenance of the system(s)?
- Who is providing the funding for capital expenditures and recurring costs?

“WHAT...”

- What is the overall problem statement being addressed by this deployment?
- What are the specific user needs from each stakeholder?
- What are the intended Connected Vehicle applications proposed on this project?
- What hardware and software will be required to facilitate the necessary messaging and applications?
- What messages are being transmitted and received between the roadside infrastructure and vehicles?

“WHEN...”

- When will equipment need to be serviced, repaired, or replaced?
- When will different messages be transmitted and under what conditions?

“WHERE...”

- Where will roadside hardware and backend equipment be installed?
- Where will application-specific data be collected, stored, or processed?

“WHY...”

- Why are the proposed systems or applications required?

“HOW...”

- How will information be provided to road users to real-time?
- How will data be exchanged from one system to another?
- How will the systems function differently in various scenarios (e.g., normal operations, failed state, emergency)?

For Specific Templates Please see FDOT [Systems Engineering](#).^{xxxii} In particular, there is a concept of operations template (Form FM-SE-01)

A2. Ch3.2 - Systems Testing and Validation Plan

The Systems Testing Plan is typically comprised of three distinct levels of acceptance testing that further subdivide and describe the field installation testing and system testing described in FDOT specifications and required on projects.

- **Field Acceptance Testing (FAT)** – also referred to as “stand-alone testing” is the first component of field installation testing; this is a device-level test to confirm the individual components of the system are functioning properly and that the initial installation and configuration of devices has been properly completed. This procedure is focused on verifying proper physical installation, configuration, and basic function of field devices at the site of the installation and each device is tested individually without reliance on other system components. Most activities will be completed using only a locally connected laptop. For example:
 - Verify that physical construction has been completed as detailed in the Plans
 - Verify RSU is mounted firmly and does not move or rotate
 - Verify RSU is properly grounded
 - Verify RSU mounting height and location is as identified in the FCC site registration
 - Verify all wire and cable connections are correct and secure
 - Verify all cabling provide drip loops
 - Verify all device ports are sealed and watertight
 - Verify proper voltages for all power supplies and related power circuits.
 - Connect devices to the power sources
 - Verify RSU is operational
 - Verify the power LEDs on roadside equipment illuminates
 - Log in to CV equipment and verify access to user interface
 - Verify factory default username and password are provided
 - Verify the configuration of CV equipment network interfaces
 - Verify RSU is provided physical network connection and is configured with appropriate IP address, default gateway, and other network parameters
 - Verify successful *PING* of RSU at default settings
 - Verify accuracy of system time
 - Verify that there is a MapData file loaded on the RSU, or other store and repeat messages, as appropriate
- **Subsystem Acceptance Testing (SSAT)** – SSAT is the next step in field installation testing following successful completion of the FAT. This testing is used to verify that all field system components have been installed and integrated with the organization’s network properly. During SSAT, field installation testing is expanded to confirm data flows between various devices of the system are occurring properly. This test is often performed at the installed site using a remote login to the SunGuide central software platform or proprietary vendor software, as appropriate. The testing procedures should include a review of the data transmitted and received from the system for accuracy and completeness. The following provides example SSAT activities, dependent upon the specific applications and functionality of the system.

- Verify MAP transmission.
 - Verify MAPdata from is being broadcast by RSU (e.g., receipt and display of messages on OBU or appropriate testing tool)
- Verify SPAT transmission.
 - Verify controller is transmitting SPAT to RSU
 - Verify SPAT broadcast from RSU
- Verify BSM receipt and forwarding
 - Verify RSU receives and forwards BSMs
- Verify TIM transmission
 - Verify TIM broadcast from RSU
 - Note, at this stage of testing TIM generation can be manually completed using laptop connected locally*
- Verify Emergency Vehicle Preemption (EVP) / Transit Signal Priority (TSP) application
 - Verify RSU receives SRM from OBU
 - Verify controller receives high-priority request from RSU
 - Verify RSU receives SSM from controller
 - Verify OBU receives SSM broadcast from RSU
- **System Acceptance Testing (SAT)** – the final stage of acceptance testing is performed on the entire system to verify the end-to-end integration and functionality of all components. System Testing includes verifying all field devices are configured and operational. This includes verifying that CV equipment included in the overall project is fully functional within the SunGuide central software platform and other central software, as appropriate, and each device is properly enrolled within the statewide Security Credentials Management Systems (SCMS). The following provides example SAT activities and should be modified to address the specific applications and functionality for the project.
 - Verify communications between field equipment and central network (e.g., TMC)
 - Verify RSU is integrated into SunGuide central software platform, as applicable
 - Verify RSU is integrated into other software systems, as applicable (e.g., vendor provided cloud-based systems, etc.)
 - Verify CV application functionality through drive testing
 - Verify SPAT information is accurate and matches intersection operations
 - Verify TIM generated from SunGuide is broadcast by RSU and received by OBU
 - Verify RSU is receiving certificate top-offs from statewide SCMS
 - Verify data forwarding and connectivity with other third-party systems (e.g., DEPOT)

For Specific Templates Please see FDOT [Systems Engineering](#). There are various Systems Test Plan template and Systems Validation Plan template.

A2. Ch3.3 - Requirements Traceability and Verification Matrix

The Department maintains a well-defined RTVM template with detailed instructions and guidance on how to complete the document. Example below:

REQUIREMENTS TRACEABILITY VERIFICATION MATRIX										
Project Name:		I-75 Florida's Regional Advanced Mobility Elements								
Project Description:		Connected Vehicle equipment installation on I-75 and numerous arterial corridors in Alachua County, FL								
Project Manager Name:		Pete Vega								
Agency/Firm:		AtkinsRealis								
User Need ID	User Need Summary	Detailed Requirement ID	Detailed Requirement Summary	Document Section	DR Source Document	Verification Test Case ID	Compliance (Y/N/Partial/NA)	Notes/Comments/Date	Reviewer Initials	FDOT Initials
UN009	Provide real-time Signal Phase and Timing (SPAT) information to motorists.	DR001	Furnish and install C-V2X Roadside Units at signalized intersections capable of transmitting SPAT.	T681	TSP	TC015	Yes	RSU provided meets the SAE J2735 standard. Verified using testing-level OBU.	RM	
UN009	Provide real-time Signal Phase and Timing (SPAT) information to motorists.	DR002	Install C-V2X SPAT module within controller assembly.	671	MSP	TC007	Yes	Software module add-on to controller purchased, integrated by vendor.	RM	
UN012	Collect real-time positional information for vehicle - including location, speed, heading.	DR003	Furnish and install C-V2X Roadside Units capable of receiving Basis Safety Messages (BSM).	T68-1	TSP	TC001	Yes	RSU provided meets the SAE J2735 standard. Verified using testing-level OBU.	RM	

Figure 3-22: Example RTVM using the adopted Department template.

For Specific Templates Please see FDOT [Systems Engineering](#). There is a RTVM template.

A2. Ch3.4 - Communications Field Review Questionnaire

(1)	Is the proposed site currently connected to an active network?	<input type="checkbox"/> Yes	<input type="checkbox"/> No
(1a)	If (1) is "Yes", identify the maintaining agency for the network.		
(1b)	If (1) is "Yes", identify the current network communication medium.	<input type="checkbox"/> Fiber Optics <input type="checkbox"/> Cellular Modem <input type="checkbox"/> Point-to-Point Wireless <input type="checkbox"/> Twisted-Pair	
(2)	If (1) is "No", is existing network communications available within the immediate vicinity of the project limits?	<input type="checkbox"/> Yes	<input type="checkbox"/> No
(2a)	If (2) is "Yes", identify the maintaining agency for the network.		
(2b)	If (2) is "Yes", identify the current network communication medium.	<input type="checkbox"/> Fiber Optics <input type="checkbox"/> Point-to-Point Wireless	
(3)	Does the proposed site currently include a working network switch?	<input type="checkbox"/> Yes	<input type="checkbox"/> No
(3a)	If (3) is "Yes", how many copper (RJ-45) ports are available in the switch? Identify if any available ports in the switch are designated as shared ports.		
(3b)	Identify the data transfer rate for copper (RJ-45) ports (e.g., 10/100). Identify the data transfer rate for fiber optic or SFP ports.		
(4)	Determine the available signal strength of the cellular network – preferably using a device either on the AT&T or Verizon network.		

A2. Ch3.5 - Power Field Review Questionnaire

(1)	Verify whether power is provided to the existing site currently.	<input type="checkbox"/> Yes	<input type="checkbox"/> No
(1a)	If (1) is "Yes", identify the electrical utility agency owner.		
(1b)	If (1) is "Yes", identify the current power source type.	<input type="checkbox"/> Direct (grid) <input type="checkbox"/> Solar (off-grid)	

(2)	If (1) is “No”, is existing utility electrical service available within the immediate vicinity of the project limits?	<input type="checkbox"/> Yes	<input type="checkbox"/> No
(2a)	If (2) is “Yes”, identify the electrical utility agency owner.		
(2b)	If (2) is “Yes”, identify the physical infrastructure for the existing electrical service connection.	<input type="checkbox"/> Underground <input type="checkbox"/> Overhead	
(2c)	If (2) is “Yes”, confirm the incoming voltage of the available electrical service (in volts).	_____ Volts	
(2d)	If (2) is “Yes”, identify the phase of the available electrical service.	<input type="checkbox"/> Single-Phase <input type="checkbox"/> Three-Phase	
(4)	If (1) is “Yes”, identify the existing infrastructure components for the electrical subsystem.	<input type="checkbox"/> Service Meter <input type="checkbox"/> Step-Down Transformer <input type="checkbox"/> Step-Up Transformer <input type="checkbox"/> Service Disconnect <input type="checkbox"/> Main Disconnect <input type="checkbox"/> Generator	
(5)	If (1) is “Yes”, identify the existing in-cabinet equipment related to the electrical subsystem.	<input type="checkbox"/> Main Power Panel <input type="checkbox"/> Power Strip (RPMU) <input type="checkbox"/> Power Strip (Standard) <input type="checkbox"/> UPS w/ Batteries <input type="checkbox"/> Auto Transfer Switch	
(5a)	If the selection for (5) includes “Main Power Panel”, identify the main circuit breaker rating (in amps).	_____ Amps	
(5b)	If the selection for (5) includes “Power Strip (RPMU)”, identify the total number of plugs and the number of available plugs for future use.	_____ Total _____ Available	
(6)	Verify whether the existing cabinet is properly grounded.	<input type="checkbox"/> Yes	<input type="checkbox"/> No

A2. Ch3.5 – Structures Field Review Questionnaire

(1)	Verify if the existing site includes roadside structures.	<input type="checkbox"/> Yes	<input type="checkbox"/> No
(1a)	If (1) is “Yes”, identify the structure type(s).	<input type="checkbox"/> Steel Device Pole <input type="checkbox"/> Concrete Device Pole <input type="checkbox"/> Overhead Sign Structure <input type="checkbox"/> Steel Mast Arm <input type="checkbox"/> Concrete Span Wire <input type="checkbox"/> Monotube Structure <input type="checkbox"/> Overhead Truss <input type="checkbox"/> Multi-Column Sign	
(2)	If (1) is “No”, confirm the existing site location suitable to accommodate a new structure installation.	<input type="checkbox"/> Yes	<input type="checkbox"/> No
(2a)	If (2) is “No”, identify the potential concerns for installation of new structure. Right-of-way limits Existing utilities (i.e., overhead, underground) Environmental concerns (e.g., wetlands, threatened species) Clear zone – horizontal offset Limited available space (e.g., walls, drainage)		
(3)	Identify the relative condition of the existing structure, as determined through on-site visual inspection.	<input type="checkbox"/> Good <input type="checkbox"/> Fair <input type="checkbox"/> Poor	
(3a)	Identify if the structure contains horizontal or longitudinal cracking.	<input type="checkbox"/> Yes	<input type="checkbox"/> No

(3b)	Identify if the structure contains significant rusting or corrosion.	<input type="checkbox"/> Yes	<input type="checkbox"/> No
(3c)	Identify if the structure contains obvious impact damage.	<input type="checkbox"/> Yes	<input type="checkbox"/> No
(3d)	Identify if the structure upright is leaning or off-plumb.	<input type="checkbox"/> Yes	<input type="checkbox"/> No
(3e)	Identify if the structure contains anchor bolts that have been removed, do not provide a minimum of two thread beyond the top nut, loose, skewed, or missing lock nuts or washers.	<input type="checkbox"/> Yes	<input type="checkbox"/> No
(4)	If (1a) contains either "Steel Mast Arm" or "Overhead Sign Structure", verify the anchor bolt pattern matches the latest version of Standard Plans.	<input type="checkbox"/> Yes	<input type="checkbox"/> No
(5)	If (1) is "Yes", identify the existing attachments on the structure, as well as the mounting height and horizontal placement of each.	(1) (2) (3) (4) (5) (6)	

A2. Ch3.6 Cabinets, Enclosures, and Field Devices Questionnaire

(1)	Verify if the existing site includes an existing traffic signal controller cabinet assembly.	<input type="checkbox"/> Yes	<input type="checkbox"/> No
(2)	If (1) is "Yes", identify the governing standard of cabinet assembly.	<input type="checkbox"/> ATC <input type="checkbox"/> NEMA (TS-1, TS-2) <input type="checkbox"/> Caltrans (170/2070)	
(2a)	If (2a) is "NEMA (TS-1, TS-2)", identify the standard cabinet size.	<input type="checkbox"/> 4 (24"W x 46"H x 16"D) <input type="checkbox"/> 5 (30"W x 48"H x 16"D) <input type="checkbox"/> 6 (44"W x 52"H x 24"D) <input type="checkbox"/> 7 (44"W x 72"H x 24"D)	
(2b)	If (2a) is "Caltrans (170/2070)", identify the standard cabinet size.	<input type="checkbox"/> Type 332 <input type="checkbox"/> Type 333 <input type="checkbox"/> Type 552 <input type="checkbox"/> Type 662	
(3)	Document the manufacturer and model of the controller unit.	Manufacturer: _____ Model: _____	
(3a)	Identify the form factor type of controller unit.	<input type="checkbox"/> NEMA TS-1 <input type="checkbox"/> NEMA TS-2, Type 1 <input type="checkbox"/> NEMA TS-2, Type 2 <input type="checkbox"/> Caltrans 170/170E/179 <input type="checkbox"/> Caltrans 2070 /2070E/2070LX <input type="checkbox"/> Hybrid 2070/TS-2 Type 2	
(3b)	Identify the current firmware version of the controller unit.		
(3c)	Identify all specific software applications and modules uploaded to the controller unit.	(6) (7) (8) (9) (10)	

(4)	Identify the manufacturer and model of the Malfunction Management Unit (MMU) or Conflict Monitor Unit (CMU).	Manufacturer: _____ Model: _____	
(5)	Identify the type(s) of vehicle detection systems present within the intersection for stop bar detection (presence).	<input type="checkbox"/> Inductive Loops <input type="checkbox"/> Microwave Radar <input type="checkbox"/> Video (standard) <input type="checkbox"/> Thermal Imaging <input type="checkbox"/> Wireless Magnetometer <input type="checkbox"/> Other (e.g., hybrid) <input type="checkbox"/> n/a	
	Identify the type(s) of vehicle detection systems present within the intersection for advanced detection (pulse).	<input type="checkbox"/> Inductive Loops <input type="checkbox"/> Microwave Radar <input type="checkbox"/> Video (standard) <input type="checkbox"/> Other (e.g., hybrid) <input type="checkbox"/> n/a	
(5a)	If (5) is “Microwave Radar”, identify the manufacturer and model of the in-cabinet system, as well as the total number of sensors.	Manufacturer: _____ Model: _____ No.: _____	
(5b)	If (5) is “Video (standard)”, identify the manufacturer and model of the in-cabinet system, as well as the total number of sensors.	Manufacturer: _____ Model: _____ No.: _____	
(5c)	If (5) is “Thermal Imaging”, identify the manufacturer and model of the in-cabinet system, as well as the total number of sensors.	Manufacturer: _____ Model: _____ No.: _____	
(5d)	If (5) is “Wireless Magnetometer”, identify the manufacturer and model of the in-cabinet system, as well as the total number of sensors.	Manufacturer: _____ Model: _____ No.: _____	
(6)	Identify whether or not the intersection includes hardware for special operations (e.g., emergency vehicle preemption, transit signal priority).	<input type="checkbox"/> Yes	<input type="checkbox"/> No
(6a)	If (6) is “Yes”, identify the operational function of the hardware, manufacturer and model of the system, and the total number of sensors.	Function: _____ Manufacturer: _____ Model: _____ No.: _____	

(7)	Identify the total number of detection channels available within the controller cabinet assembly.	<input type="checkbox"/> 16 channels <input type="checkbox"/> 32 channels <input type="checkbox"/> 48 channels <input type="checkbox"/> 64 channels
(7a)	Identify the total number of bus interface units (BIU) present within the controller cabinet assembly.	
(7b)	Identify the total number of detector card slots within the controller cabinet assembly, as well as how many are available.	Total: _____ Available: _____
(7c)	Identify the total number of Synchronous Data Link Communications (SDLC) interfaces within the SDLC bus of the traffic controller cabinet and how many interfaces are available.	Total: _____ Available: _____
(7d)	Identify the total number of channels available on the detector panel within the controller cabinet assembly, as well as how many are available.	Total: _____ Available: _____
(8)	Identify the available power source(s) within the controller cabinet assembly.	<input type="checkbox"/> Power Strip (standard) <input type="checkbox"/> RPMU (network-enabled) <input type="checkbox"/> Outlet Box <input type="checkbox"/> GFCI
(8a)	Identify the number of total and available power outlets within the controller cabinet assembly.	Total: _____ Available: _____
(8b)	If (8) is "RPMU (network-enabled)", identify the manufacturer and model of the remote power management unit (RPMU).	Manufacturer: _____ Model: _____
(9)	Identify if the controller cabinet assembly includes an uninterruptible power supply (UPS) and battery backup.	<input type="checkbox"/> Yes <input type="checkbox"/> No
(9a)	If (9) is "Yes", identify the manufacturer and model of the UPS, as well as the installation date of the batteries.	Manufacturer: _____ Model: _____ Date: _____
(10)	Identify if the existing cabinet includes available physical space for additional in-cabinet components.	<input type="checkbox"/> Yes <input type="checkbox"/> No
(11)	Identify the total number of conduit sweeps into the cabinet foundation.	
(11a)	Identify the number of spare conduits, as well as the utilization of each conduit (e.g., low-voltage, high-voltage, fiber optic, electrical service).	No. _____ (low-voltage) No. _____ (high-voltage) No. _____ (fiber optics) No. _____ (electrical)

(11b)	Identify the number of conduits with available capacity, as well as the utilization of each conduit (e.g., low-voltage, high-voltage, fiber optic, electrical service).	No. _____ (low-voltage) No. _____ (high-voltage) No. _____ (fiber optics) No. _____ (electrical)
(12)	Identify if the signalized intersection includes supplemental field devices. For each field device identify the manufacturer and model. CCTV Camera Bluetooth Travel Time Reader Connected Vehicle Roadside Unit (RSU) Intersection Movement Count (IMC) Camera	Device Type: _____ Manufacturer: _____ Model: _____ <hr/> Device Type: _____ Manufacturer: _____ Model: _____ <hr/> Device Type: _____ Manufacturer: _____ Model: _____ <hr/> Device Type: _____ Manufacturer: _____ Model: _____

Table 3-9: Field Review Questionnaire – Intelligent Transportation System Cabinet Assembly

(1)	Verify if the existing site includes an existing Intelligent Transportation Systems (ITS) cabinet assembly.	<input type="checkbox"/> Yes <input type="checkbox"/> No
(2)	If (1) is “Yes”, identify the cabinet assembly standard or size.	<input type="checkbox"/> Type 332/334 <input type="checkbox"/> Type 332D <input type="checkbox"/> Type 336 <input type="checkbox"/> Type 336S <input type="checkbox"/> Type P44 <input type="checkbox"/> Other (NEMA 3R)
(2a)	If (2) is “Other”, identify the dimensions of the NEMA 3R enclosure	_____ inches (H) _____ inches (W) _____ inches (D)
(2b)	Identify the installation method for the cabinet assembly.	<input type="checkbox"/> Base Mounted <input type="checkbox"/> Structure Mounted
(3)	Identify the field devices supported by the site. For each field device identify manufacturer and model. CCTV Camera Microwave Vehicle Detection System (MVDS) Dynamic Message Sign (DMS) Roadway Weather Information System (RWIS) Bluetooth Travel Time Reader Connected Vehicle Roadside Unit (RSU) Wrong-Way Vehicle Detection System (WWVDS)	Device Type: _____ Manufacturer: _____ Model: _____ <hr/> Device Type: _____ Manufacturer: _____ Model: _____

		Device Type: _____ Manufacturer: _____ Model: _____
		Device Type: _____ Manufacturer: _____ Model: _____
(4)	Identify the available power source(s) within the cabinet assembly.	<input type="checkbox"/> Power Strip (standard) <input type="checkbox"/> RPMU (network-enabled) <input type="checkbox"/> Outlet Box <input type="checkbox"/> GFCI
(4a)	Identify the number of total and available power outlets within the cabinet assembly.	Total: _____ Available: _____
(4b)	If (4) is "RPMU (network-enabled)", identify the manufacturer and model of the remote power management unit (RPMU).	Manufacturer: _____ Model: _____
(5)	Identify if the cabinet assembly includes an uninterruptible power supply (UPS) and battery backup.	<input type="checkbox"/> Yes <input type="checkbox"/> No
(5a)	If (5) is "Yes", identify the manufacturer and model of the UPS, as well as the installation date of the batteries.	Manufacturer: _____ Model: _____ Date: _____
(6)	Identify if the existing cabinet includes available physical space for additional in-cabinet components.	<input type="checkbox"/> Yes <input type="checkbox"/> No
(6a)	If (6) is "Yes", identify the method of installation for new in-cabinet equipment.	<input type="checkbox"/> DIN Rail <input type="checkbox"/> Shelf-Mounted
(7)	Identify the total number of conduit sweeps into the cabinet foundation.	
(7a)	Identify the number of spare conduits, as well as the utilization of each conduit (e.g., low-voltage, fiber optic, electrical service).	No. _____ (low-voltage) No. _____ (fiber optics) No. _____ (electrical)
(7b)	Identify the number of conduits with available capacity, as well as the utilization of each conduit (e.g., low-voltage, fiber optic, electrical service).	No. _____ (low-voltage) No. _____ (fiber optics) No. _____ (electrical)

A2. Ch3.7 Associated Infrastructure Questionnaire

(1)	Identify if there is an existing conduit pathway(s) between the cabinet assembly and endpoints (e.g., structure).	<input type="checkbox"/> Yes <input type="checkbox"/> No
(1a)	If (1) is "Yes", identify the nominal diameter size for the conduit pathway.	<input type="checkbox"/> 1-inch <input type="checkbox"/> 1.5-inch <input type="checkbox"/> 2-inch <input type="checkbox"/> 3-inch

(1b)	If (1) is "Yes", identify the total number of conduits in the run.	
(1c)	Identify the number of spare (empty) conduits in the run.	
(1d)	Identify the number of conduits with available capacity in the run.	
(1e)	Identify the utilization of conduit(s) in the run (e.g., low-voltage signal, high-voltage signal, fiber optics, electrical service).	(5) _____ (6) _____ (7) _____ (8) _____ (9) _____ (10) _____
(2)	Identify condition of underground pull boxes within the conduit run for the feasibility of installing new cabling.	<input type="checkbox"/> Good (useable) <input type="checkbox"/> Fair (questionable) <input type="checkbox"/> Poor (unusable)
(3)	Identify if the conduit run includes aboveground conduit with risers.	<input type="checkbox"/> Yes <input type="checkbox"/> No
(3a)	If (3) is "Yes", identify the total number and available cabling ports within the weatherhead.	Total: _____ Available: _____

A2. Ch3.8 Traffic Control Device Permits

If a project requires approval for a new system, device, or equipment, the Engineer will need to work with the District to complete and submit a "Request for Traffic Control Device Permit." Submitted to Central Office by the District Traffic Operations Engineer (DTOE), the completed form will need to provide generalized information about the project, as well as specific product information and the justification for its specific need. Each form will include the following:

- **Sponsorship and Concurrence** – identifies the Department sponsor for the requested traffic control device
- **Product Information** – determines the exact model(s) of the proposed hardware and intended purpose
- **Applicant Information** – provides general contact information for the manufacturer of the product
- **Project Information** – identifies the information for the project including financial project identification number (FPID), project name, and location
- **Justification** – identifies the specific needs and benefits for the product and why this particular device was selected for evaluation

FDOT
Florida Department of Transportation
Traffic Engineering and Operations Office
Traffic Engineering Research Laboratory
Request for Traffic Control Device Permit

As allowed by Florida Statute 316.0745 (8), this completed form and attached information submitted by the FDOT District Traffic Operations Engineer (or designee) serves to concur with the request that the product and number of units described herein be considered for a Traffic Control Device Permit on the project indicated below.

I. SPONSORSHIP AND CONCURRENCE
Maintaining Agency: _____ Contact Person: _____
FDOT District: _____ FDOT District Traffic Operations Engineer: _____

II. PRODUCT INFORMATION
Product Name: _____ Model: _____
Proposed Use: _____

III. APPLICANT INFORMATION
Vendor Name: _____ Website: _____
Contact Person/Title: _____ E-mail: _____
Address: _____ Phone: _____
City: _____ State/Province: _____
Zip: _____ Country: _____

IV. PROJECT INFORMATION
Project Number: _____ City/Country: _____
Number of Units Proposed for Installation: _____
Intersections/Roads and/or Mile Posts for Installation: _____

V. JUSTIFICATION
Benefits to state of Florida (e.g., safety, efficiency, cost): _____
Are there similar products on the APL? _____ If yes, indicate product features and benefits currently not available from APL listed products. _____
Is there an FDOT product specification for the product type? _____ If yes, indicate requirements needed but not listed in current product specification. _____

FDOT Traffic Engineering and Operations Office
Traffic Engineering Research Laboratory
Form 08-22-01-2 (Effective 1/15/2020)
Page 1 of 2
(This is an uncontrolled document. Contact FDOT for latest version.)

Figure 3-44: Example Request for Traffic Control Device Permit

A2. Ch5.1 Data Collection for FCC Site Registration

Site Data		Imperial Elevation Reference Information	
Proposed Site Name:		Elevation of Site AMSL:	Feet
Antenna Latitude (XX° XX' XX.X" N):		Pole Height w/out App:	Feet
Antenna Longitude (XX° XX' XX.X" W):		Pole Height with App:	Feet
City:		Elevation of Device AGL:	Feet
County:		Center Line of Antenna AGL:	Feet
State:	Florida		
Major Street or Corridor:		INSERT PHOTO OF SUPPORT	
Minor Street or Milepost:			
Elevation of Site Above Mean Sea Level (AMSL) in meters (calculated value):	0.0		
Overall Height Above Ground Level (AGL) without appurtenances of the support structure in meters (calculated value):	0.0		
Overall Height Above Ground Level (AGL) with appurtenances on the support structure in meters (calculated value):	0.0		
Support Structure Type:	Mast Arm (UPOLE)		
Transmitter Antenna Data			
Manufacturer of the Antenna:			
Model Number of the Antenna:			
Antenna Gain in dBi:			
Beamwidth in degrees:	360.0		
Center Line of Antenna height AGL in meters (calculated value):	0.0		
Azimuth in degrees:	360.0		
Elevation Angle in Degrees:	0.0		
Transmitter Data			
Equipment Class: Choose the output power for the corresponding equipment class from drop down. Default is Class D. A= 0 dBm Max Output Power (15-meter communication zone) B= 10 dBm Max Output Power (100-meter communication zone) C= 20 dBm Max Output Power (400-meter communication zone) D= 28.8 dBm Max Output Power (1000-meter communication zone)	28.8		
Frequencies: Default is all.	<input checked="" type="checkbox"/> 5895 - 5905 MHz <input checked="" type="checkbox"/> 5905 - 5925 MHz		
Maximum Output Power (calculated value):	28.8		
EIRP (calculated value):	28.8		
Site Registration File #s (To be completed by FDOT CO ITS Communications Administrator):			

A2. Ch5.2 ITSFM Asset Form

For Specific Templates Please see ITS Facility Management System RSU Attribute Form [[Hyperlink](#)]^{xxxiii}.

^{xxxii} FDOT Systems Engineering <https://www.fdot.gov/traffic/ITS/Projects-Deploy/SEMP.shtm>

^{xxxiii} ITS Facility Management System Road Side Unit (RSU) Attribute Form <https://fdotwww.blob.core.windows.net/sitefinity/docs/default-source/traffic/itsfm/documents/datacollection/2022/itsfm062-roadside-unit-form.pdf?sfvrsn>



Transportation Systems Management & Operations

