

FDOT Transportation Innovation Initiative: UHPC – Design Innovation

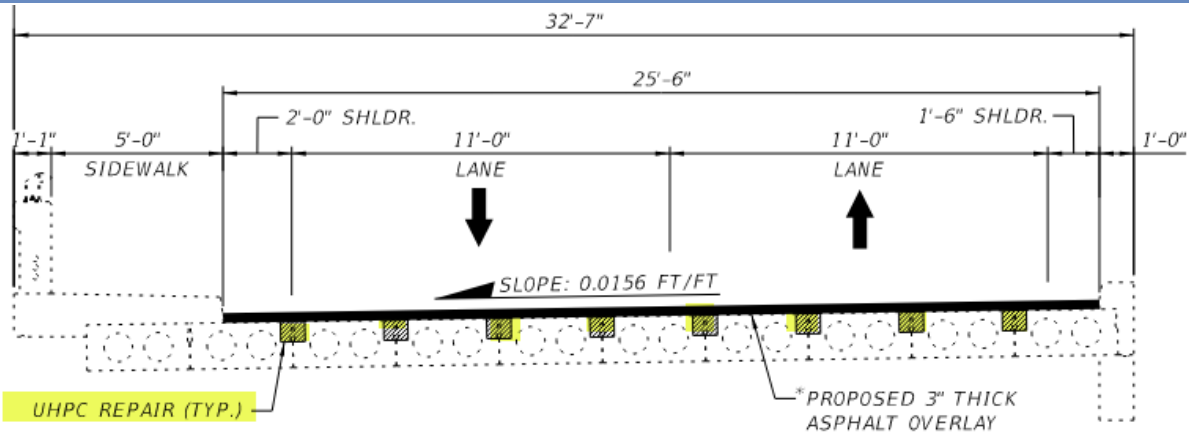

Fast
Facts:
Ultra-High
Performance
Concrete



Project Location: FDOT District 2
Jacksonville
Duval, Florida

Agency: Florida Department of Transportation

URL: <http://www.fdot.gov/structures/innovation/UHPC.shtm>

Project Name: SR115 (Arlington Expy) over Red Bay Branch
Bridge Nos. 720136 & 720148
FPID: 443310-1 (T2934)

Project Description: Sonovoid PSB longitudinal joint repairs with UHPC.

Project Purpose & Need: Reflective cracks in the asphalt overlay, indicating separation of the sonovoid units at the joints between the units. Bridge work activities involved hydro-demolition of longitudinal joints between PSB precast units and filling connections with supplemental tie bars and UHPC.

**Overall Budget/
Cost Estimate:** \$20M (Construction Contract)
\$4M (Joint Repair w/ UHPC)

What was unique about this project?

Largest project use of UHPC (98 CY) for existing sonovoid PSB joint repairs in Florida. 29-spans with 8-joints each = approx. 6,400 LF.

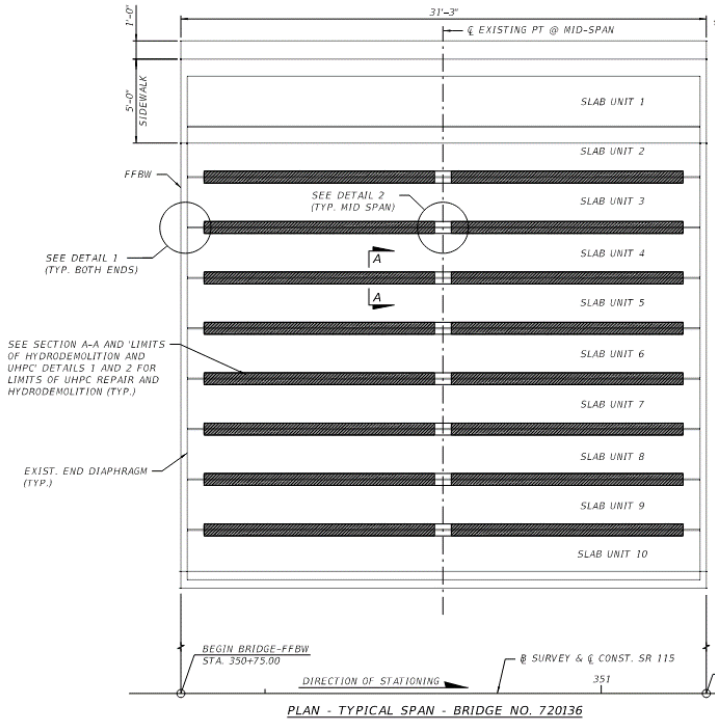

Describe Traditional Approach:

Traditional approach includes using hooked and lacing reinforcing bars within wider concrete closure pours using high early strength concrete.

Describe New Approach:

Exposure of existing reinforcing bars by hydro-demolition, with addition of supplemental tie bars enclosed in a UHPC closure pour.

Top Innovations Employed:

Utilization of UHPC connections for rapid and robust repair of damage longitudinal joint connections.

Primary Benefits Realized/Expected:

More robust and longer service life from UHPC connections. Shorter closure time for highway system bridges.

Project Estimated Start Date/Completion Date:

Spring 2023 – 2024

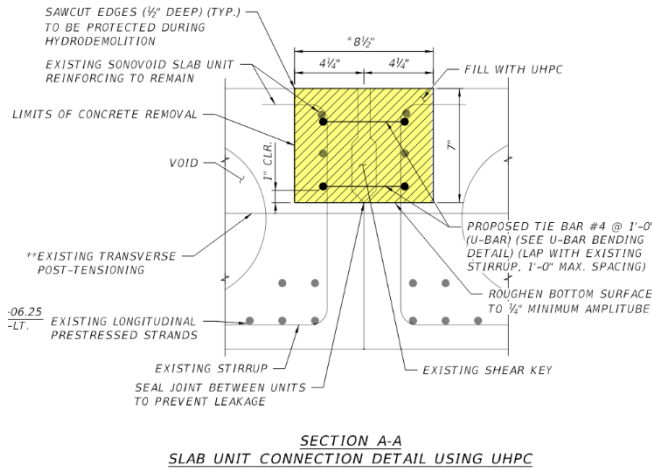

Affiliations:

PE Consultant:
Construction Contractor:
Construction Engineering Inspection:

Florida Bridge and Transportation, Inc.
TBA
TBA

Project Contact:

Engineer of Record:
FDOT Design Project Manager:

Juan Valenzuela, P.E.
Florida Bridge and Transportation, Inc.
Victor Marrero
FDOT District 2

