



Southeastern Bridge Preservation Partnership – UHPC update from FDOT

Presenter: Steve Nolan, P.E. (State Structures Design Office)

Date: September 9th, 2023



SEBPP – FDOT Design and Preservation with UHPC



Pile driving photos courtesy of Cor-Tuf UHPC

1. Introduction
2. FDOT UHPC Structural Research
3. FDOT UHPC Projects to Date
3. FDOT UHPC Pile Standard Development
4. AASHTO Guide Specifications Status
5. Discussion

FDOT Past Research Related to UHPC

- Octagon (SCP) and H-shaped (Durastress) Pile Flexural Testing
- **[BDV30-977-34: Quantifying the Effect of UHPC Fiber Dispersion and Orientation in Structural Members](#)** (FSU/Zhang)
- **[BDV29 977-28: Florida Slab Beam Bridge with Ultra-High Performance Concrete Joint Connections](#)** (FIU/Garber)
- **[BDV31 977-101: Hybrid Prestressed Concrete Bridge Girders Using Ultra-High Performance Concrete](#)** (UF/Hamilton)
- **[Large Bars Spliced in UHPC for Bridge Substructure Connections](#)** (FDOT/Freeman)

September 2023

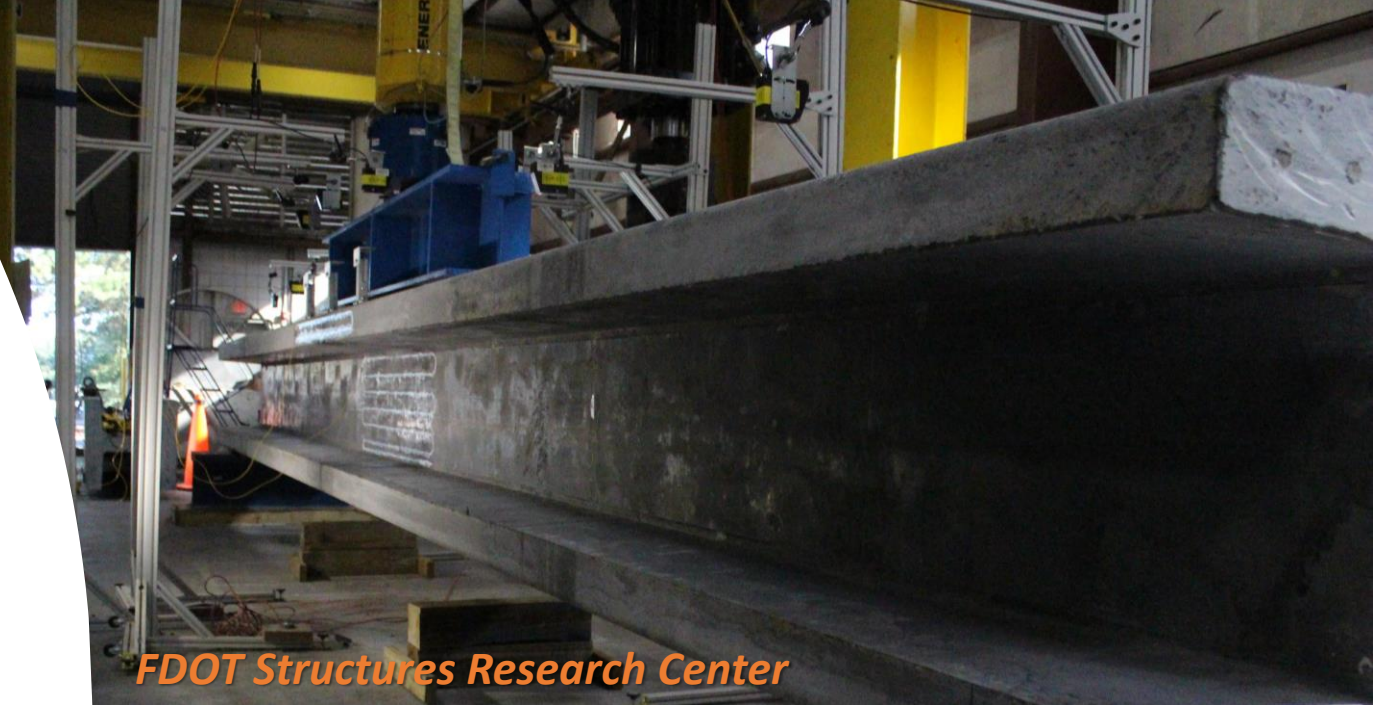

FDOT Ongoing & Future Research Related to UHPC

- ***BED30 977-05***: [Acceptable Crack Width Limit for UHPC Structural Members Under Coastal and Marine Environment](#) (FSU/Zhang)
- ***BED30 977-08***: Assessment and Optimization of the Casting Procedure for UHPC Structural Elements (FSU/Zhang)
- ***BEC96***: [Bond Performance Between Precast UHPC Substrates and Field Cast UHPC Connections](#) (FIU/Garber)
- ***BECxx***: UHPC Pile Splice Development (FIU/Garber/Mehrabi)
- Soil-Skin Friction Assessment (SRC & SMO)
- Driving Assessment of UHPC Piles (TBA)

September 2023



Where you can find UHPC in Florida:

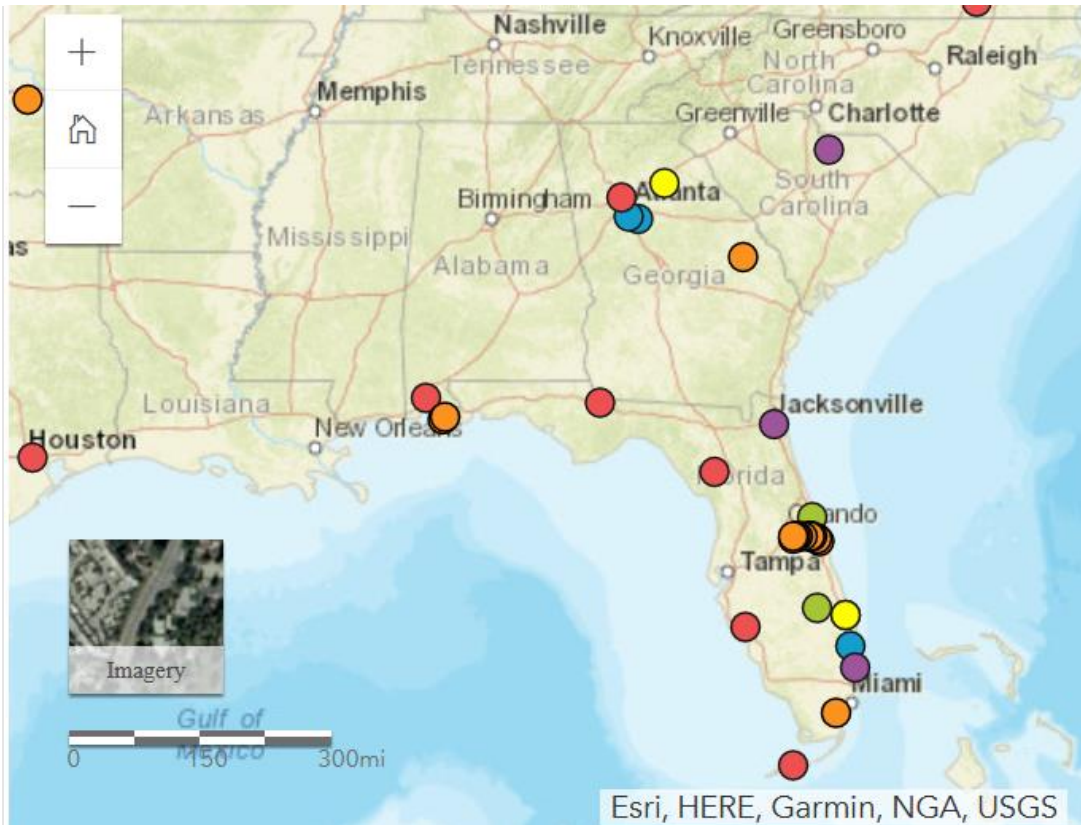

U.S. Department of Transportation
**Federal Highway
Administration**

[https://highways.dot.gov/research/structures/
ultra-high-performance-concrete/deployments](https://highways.dot.gov/research/structures/ultra-high-performance-concrete/deployments)

Where you can find UHPC in Florida: BRIGHTLINE

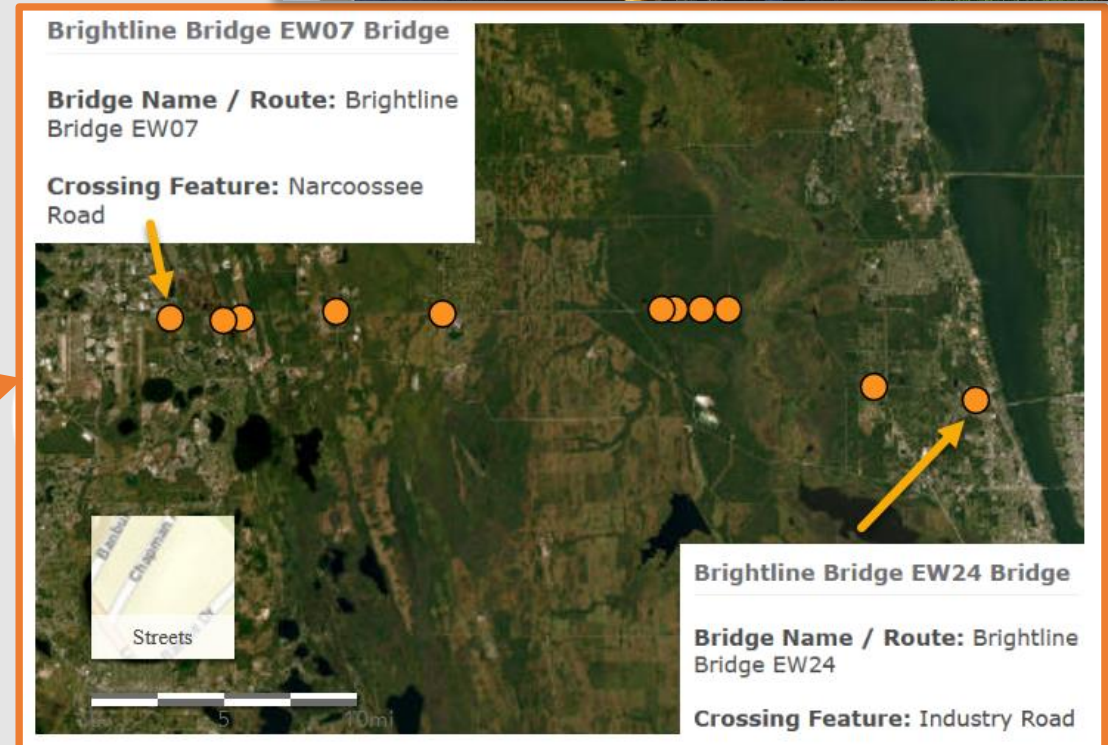
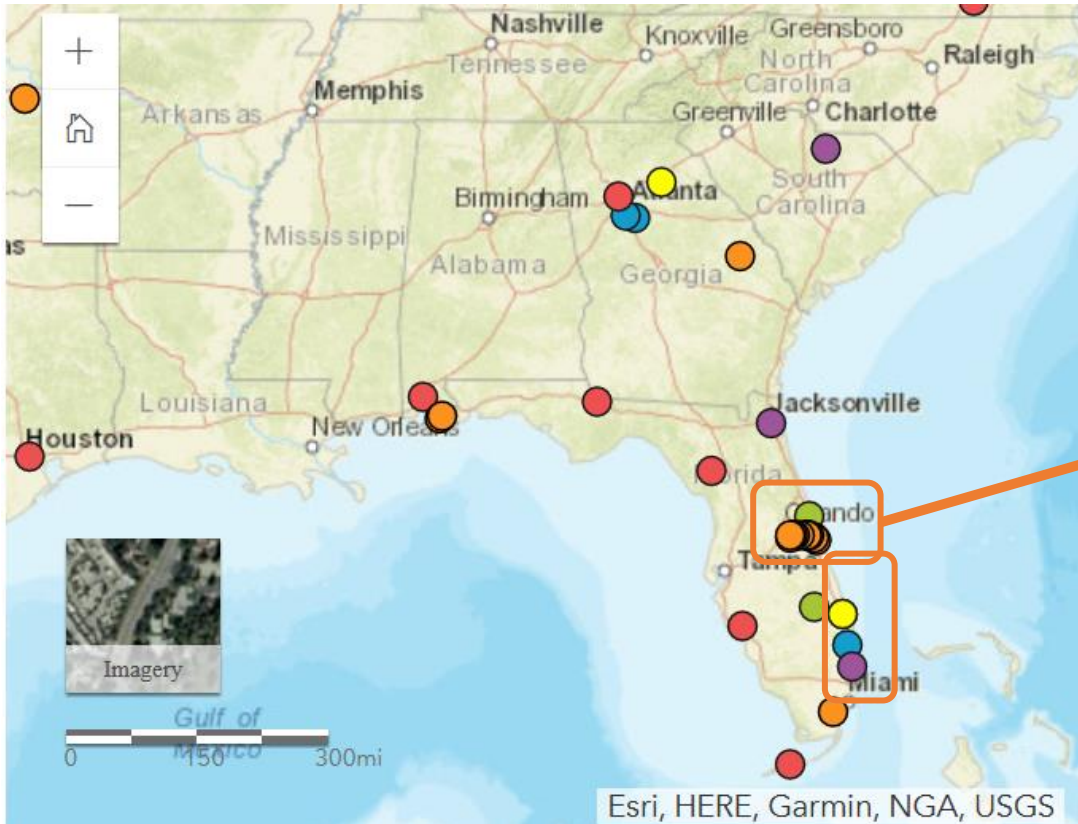

Where you can find UHPC in Florida: BRIGHTLINE

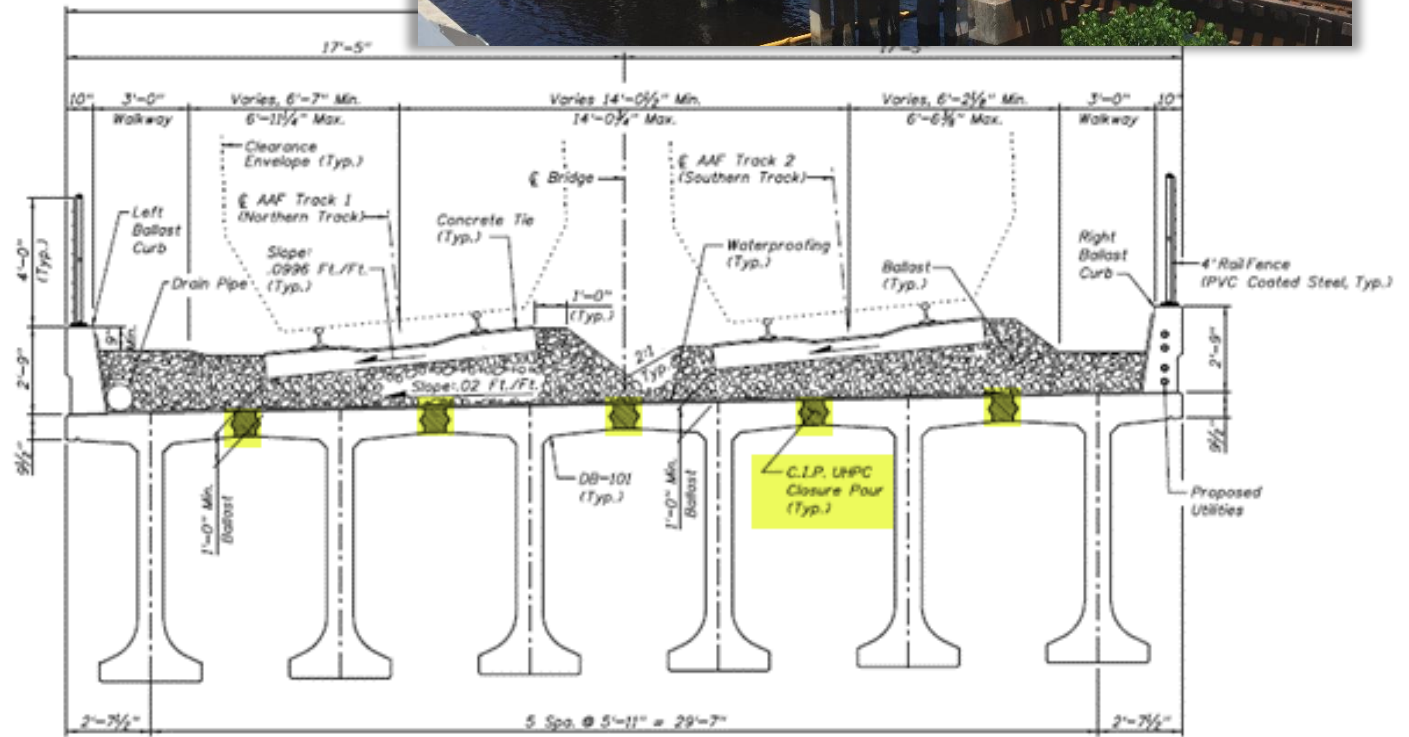
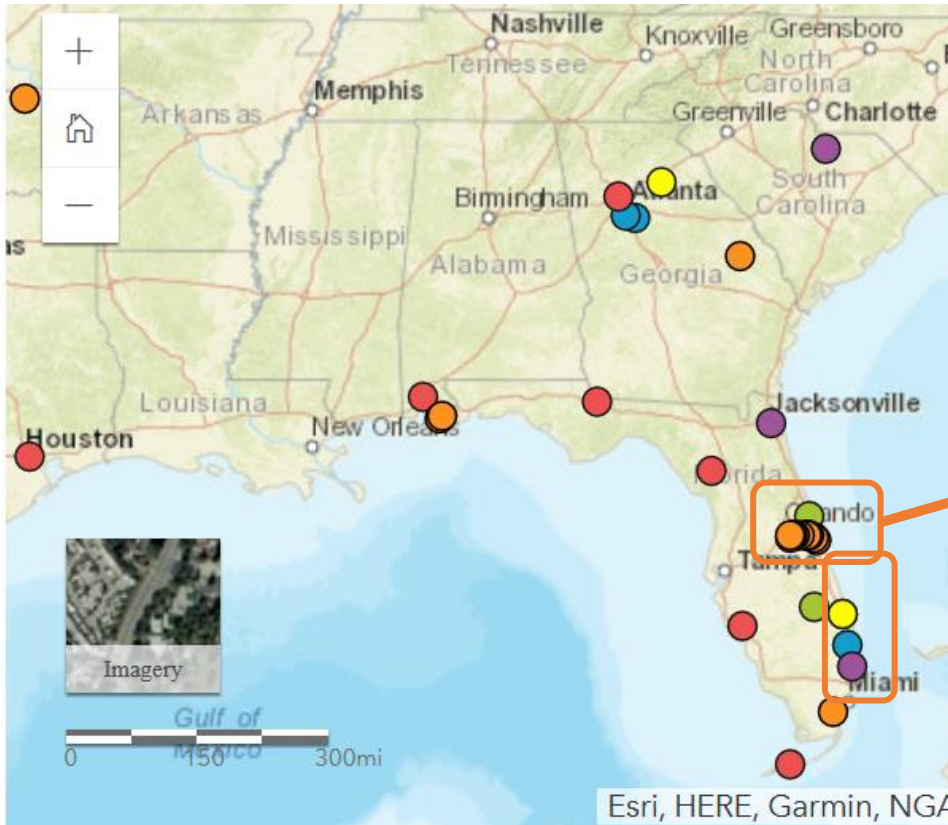

LEGEND:

DB = Decked Beam
 UHPC = Ultra High Performance Concrete

Where you can find UHPC in Florida: DISTRICT 1



- US 441/Taylor Creek ([437984-1](#)), ***Fast-Facts***: Longitudinal center joint for dual precast slabs (Contractor's redesign) – ***Complete 6/11/2018***.
- US41 over Morning Star & Sunset Waterways ([435390-1](#)) **T4500**, ***Fast Facts***: Link-slab to use UHPC with BFRP longitudinal bars – 2/27/19 letting (*Bid Tabs*) – ***Completed 10/30/2020***.
- [SR45\(US-41\) over Roberts Bay \(445941-1\)](#), **E1U17**. Sonovoid Joint Rehab with hydro-demolition & UHPC (13 CY) - Letting 2/07/2022, *Bid Tabs* - ***Completed 3/17/2023***.
- [SR25\(US-27\) NB /Fisheating Creek Overflow: \(445925-1\)](#), **T1848**. Sonovoid Joint Rehab = 7 x 36' spans x 8 joints (1,900 LF) with hydro-demolition & UHPC (21 CY) - Let 12/07/2022, *BSN* - ***status: under construction***.
- [SR82/Under Canal \(430848-1\)](#) – 04/20/23 letting. FSB without topping & UHPC joints and GRS Abutments – ***status: Letting 7/24/2024***.
- Lakeland, New York Ave/Railroad Pedestrian Overpass: ([436656-1](#)), *Precast Approach Ramp Slabs*, Production 11/08/2024; no letting date yet. ***status: Phase II review***.

Where you can find UHPC in Florida: DISTRICT 2



Ultra-high-performance concrete was used for the repair of a midspan spliced U-girder closure pour. Photo: SEMA Construction

- I-95/JT Butler Interchange, U-Beam Repair – **Complete 2017.**
- [SR115 \(Arlington Expwy\) over Red Bay Branch \(443310-1\), T2934](#). Sonovoid Joint Rehab = 29 x 31' spans x 8 joint (7,000 LF) with hydro-demo & UHPC (98 CY) – Letting 12/07/22, [BSN](#) - **status: Under construction.**

Where you can find UHPC in Florida: DISTRICT 3



- I-10 over Flat Creek ([442914-1](#)), **E3S91**, ***Fast-Facts*** - Approach Slab Replacement: Precast w/UHPC longitudinal joint (2.8 CY) – *letting 2/13/2020 (Bid Tabs)* – **Completed 10/21/20.**
- I-10 over CR268A ([445465-1](#)), **E3T49** ***Fast-Facts*** - Approach Slab Replacement - Precast w/UHPC longitudinal joint (3 CY) – *letting 7/9/2020*, **Completed 4/13/20.**
- 1-10 over Perdido River ([442913-1](#)), **E3T35**, Approach Slab Replacement: Precast w/UHPC longitudinal joint (3 CY) – *letting 6/11/2020 (Bid Tabs)*, *Began 2/8/21* - **Complete 6/3/21.**
- I-10 over Crooked Creek ([222539-3](#)) **E3U40**, Approach Slab Replacement: Precast w/UHPC longitudinal joint – *letting 10/14/21 (BSN, Bid Tabs)*, Argos-UHPC - **Completed 7/8/22.**
- West Wilson St over Turkey Ck ([439390-1](#)), UHPC Alternate B, voided PSU's; *letting 10/6/22 – status: Env. Permit issues. Changed from replacement to removal (Cancelled).*
- [I-10 over CR 191/Garcon Point Rd \(441588-1/442915-1\)](#) **T3787**– Approach Slab Replacement: Precast w/UHPC longitudinal joint, Argos-UHPC – *letting 4/28/21 (BSN)*: – **status: Complete 2023.**

Where you can find UHPC in Florida: DISTRICT 4

- SR 714/Danforth Creek ([430617-1](#)), ***Fast-Facts:*** Sonovoid Rehab: *letting 4/1/16 - Completed 2/21/17.*
- Henry Kinney Tunnel North Portal Extension ([439714-1](#)) T4582 – initially UHPC connections between vertical precast panels. *Letting 5/26/21, [Bid-Tabs](#) – Redesigned by contractor to avoid UHPC*



Where you can find UHPC in Florida: DISTRICT 5

- I-95 over CR5A ([438321-1](#)), ***Fast-Facts***: Deck Panel replacements - ***Completed 2018***.



Where you can find UHPC in Florida: DISTRICT 6



- SR 994/Quail Roost Dr./SW 200 St over Canal C-102 (441961-1) **E6M47**, Letting 8/27/20, Bid Tabs, *Joint rehab sonovoid slab units*. ceEntek Inc. - **Complete 6/3/21**.
- Monroe: US-1/Little Duck Key (436344-2) **E6M59**. **Fast-Facts**: Approach Slab Bridge Expansion Joint Repairs, Letting 2/27/20 - **Complete 10/10/20**.
- SR 924/NW 119 St Over Rio Vista Canal (441963-1, lead 439981-1), **T6516**, Sonovoid Bridge Joint Rehab=96 LF, Letting 10/27/21, BidTabs, Steelike UHPC - **Complete 4/28/23**

Where you can find UHPC in Florida... FAST-FACTS



- [I-10 over CR268A Approach Slab Replacement](#)
- [I-10 over Flat Creek Approach Slab Replacement](#)
- [I-95 over CR5A - Precast Deck Panel Replacement](#)
- [I-95/JT Butler Interchange Bridge U-Beam Repair](#)
- [SR 115/Arlington Expy over Red Bar Branch](#)
- [SR25\(US27\) NB over Fisheating Creek](#)
- [SR 714/Danforth Creek - Sonovoid Rehab](#)
- [SR 924/NW 119th St over Rio Vista Canal](#)
- [SR 994/Quail Roost Dr over Canal C-102](#)
- [US1 over Little Duck Key Channel](#)
- [US441 over Taylor Creek - Span 12 Replacement](#)
- [US41 over Sunset Waterway Link-Slab](#)
- [CR339/Waccasassa River Pile Demonstration](#)

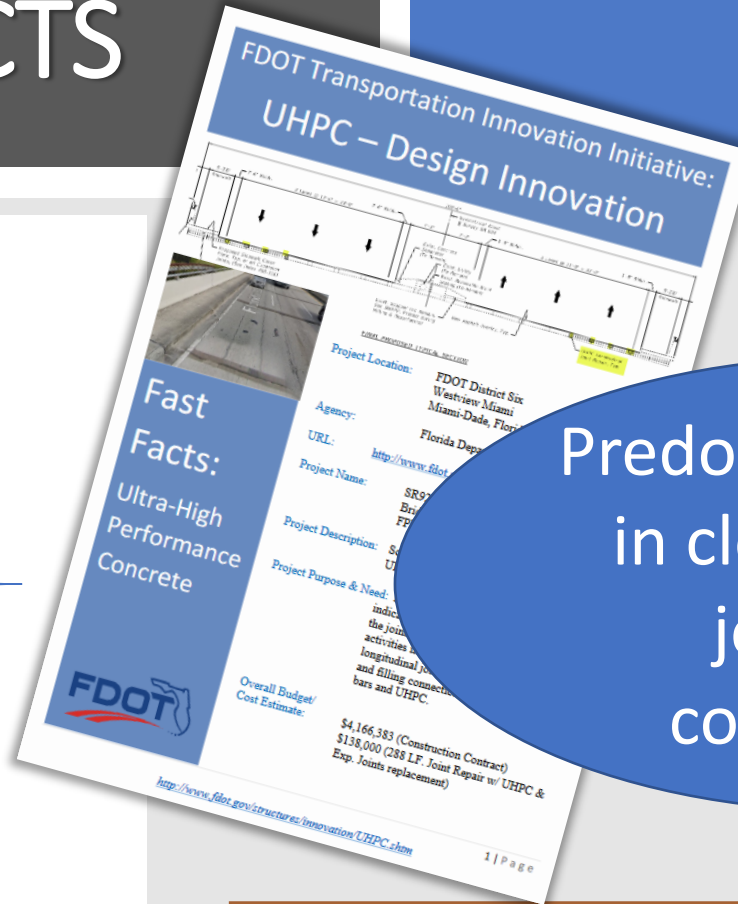

Predominantly used in closure pours, joints and connections.

Prestressed Concrete Pile

FDOT UHPC H-PILE STANDARD DEVELOPMENT



Benefits

1. **Durability:** Benefit in places where corrosion is an issue (alternative to Piles w/ SS or CFRP strands)
2. **High moment** capacity → New Alternative!
3. **Lighter weight** members
4. Permit larger driving stresses (using larger hammer and/or stroke) → **Less cracking & Potentially faster driving** with improve the efficiency.
5. Greater structural capacity → **Potentially fewer piles** required per bridge
6. UHPC material is a better fit for a precast construction vs. CIP on-site:
 1. Repetition → Consistency
 2. Better Quality Control

Challenges

1. **Cost** ~10 x conventional concrete material.
2. Pile **Splicing** (pre-planned or unplanned)
3. **“New”** Material → Material Specifications
 1. Casting Experience
 2. What should the concrete cover be for minimum durability?
 3. **Lack of Data** → Pile driving data, durability data, etc.
4. **Design Criteria** is still under development
 1. Structural Capacity (FHWA/AASHTO)
 2. Geotech Pile Analysis
 3. Scour
5. Determining a practical use for this pile type

FDOT H-PILE STANDARDS

PILE INTERACTION DIAGRAMS

b. Prestressed Concrete Piles: Use the following equations to determine the maximum allowed pile stresses:

Conventional →

$$s_{apc} = 0.7 f'_c - 0.75 f_{cpe} \quad (1)$$

$$s_{apt} = 6.5 (f'_c)^{0.5} + 1.05 f_{cpe} \quad (2a) \text{ for piles less than 50 feet long}$$

$$s_{apt} = 3.25 (f'_c)^{0.5} + 1.05 f_{cpe} \quad (2b) \text{ for piles 50 feet long and greater}$$

$$s_{apt} = 500 \quad (2c) \text{ within 20 feet of a mechanical splice}$$

where:

- s_{apc} = maximum allowed pile compressive stress, psi
- s_{apt} = maximum allowed pile tensile stress, psi
- f'_c = specified minimum compressive strength of concrete, psi
- f_{cpe} = effective prestress (after all losses) at the time of driving, psi, taken as 0.8 times the initial prestress force divided by the minimum net concrete cross-sectional area of the pile ($f_{cpe} = 0$ for dowel spliced piles).

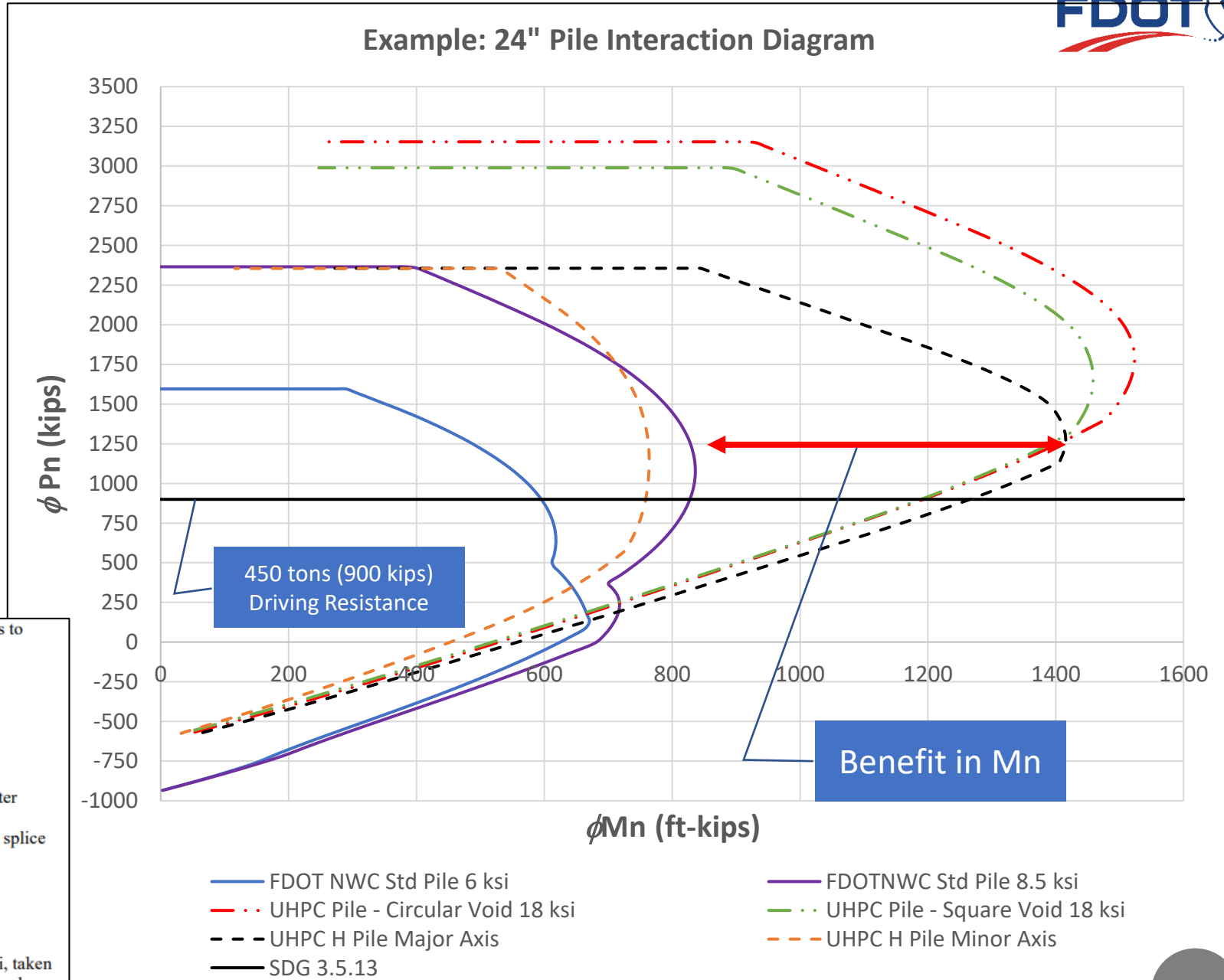

FDOT H-PILE STANDARDS

Issues with internal voids:

- Floating void (octagonal pile)
- Possible corrosion path when tying the void form material

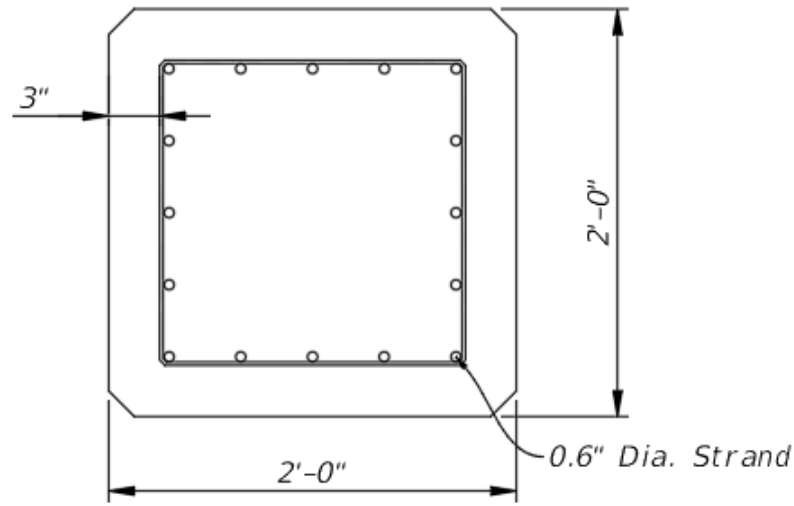

CURRENT FDOT CONCRETE STANDARD PILE



(2) 9.5" x 13" VOIDS?

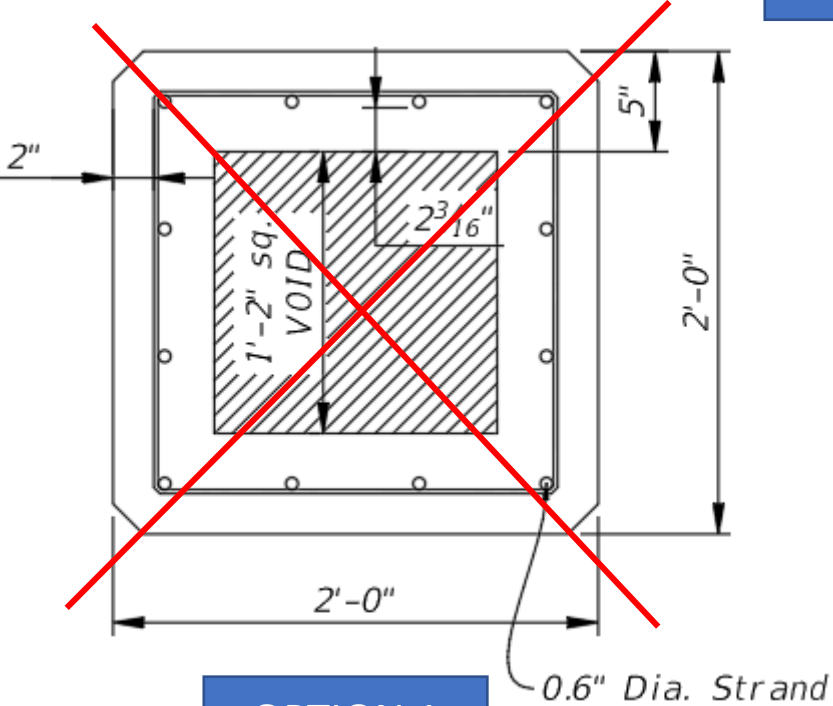

OPTION 1

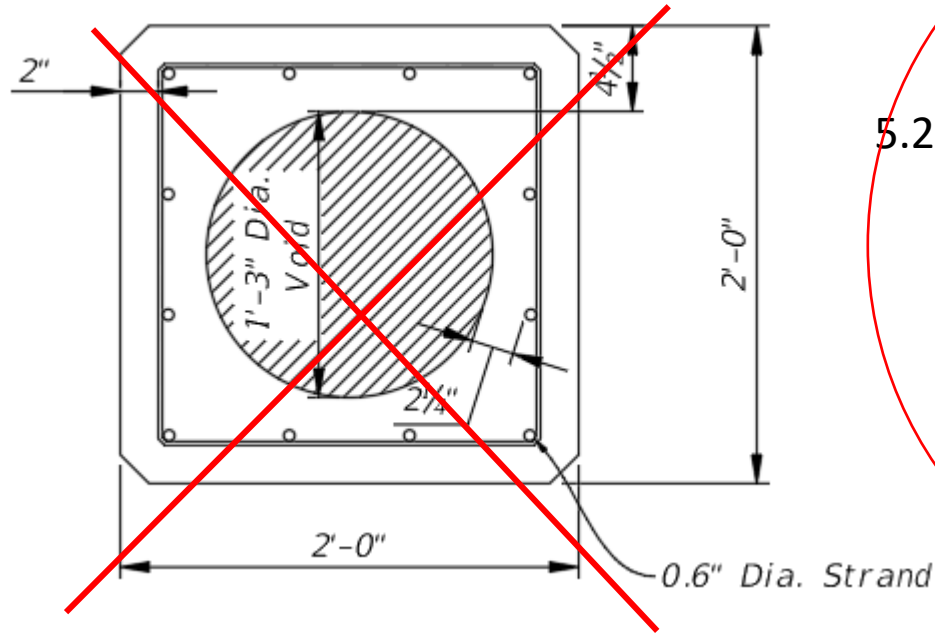

OPTION 2

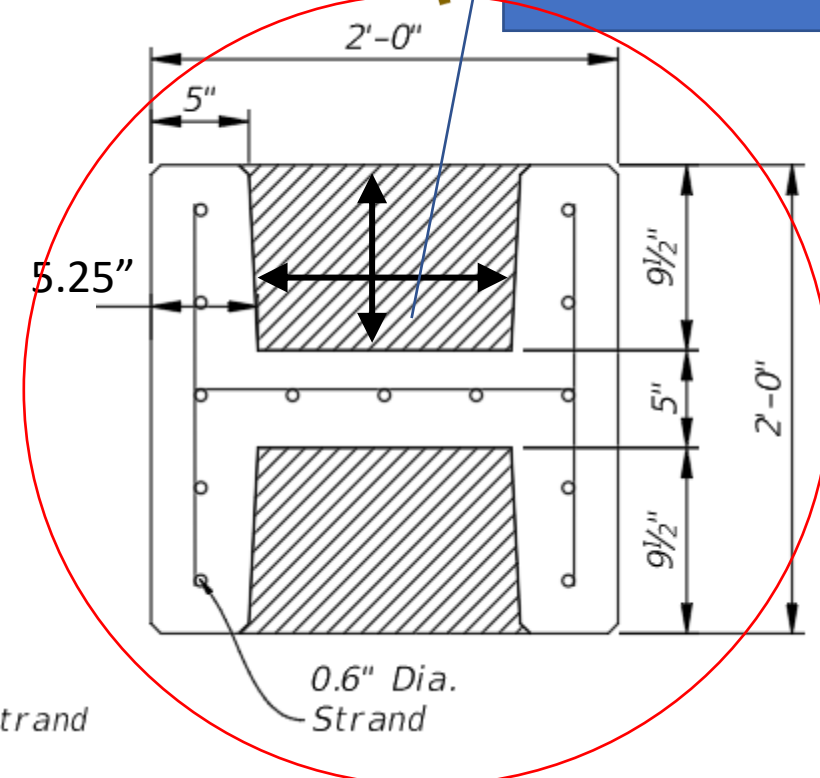

OPTION 3

FDOT H-PILE STANDARDS

FDOT Prototype (CR-339)

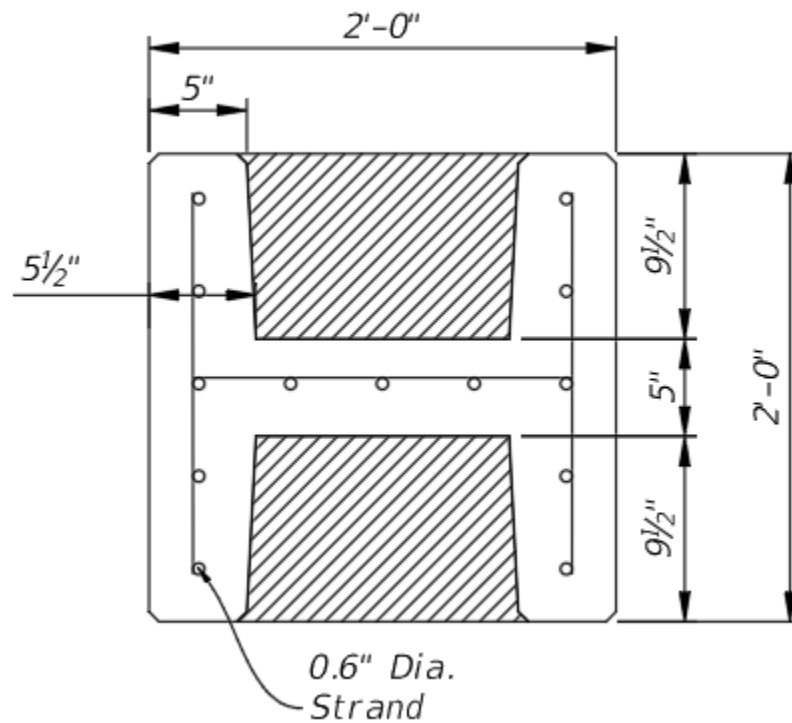

INITIAL H-SHAPE

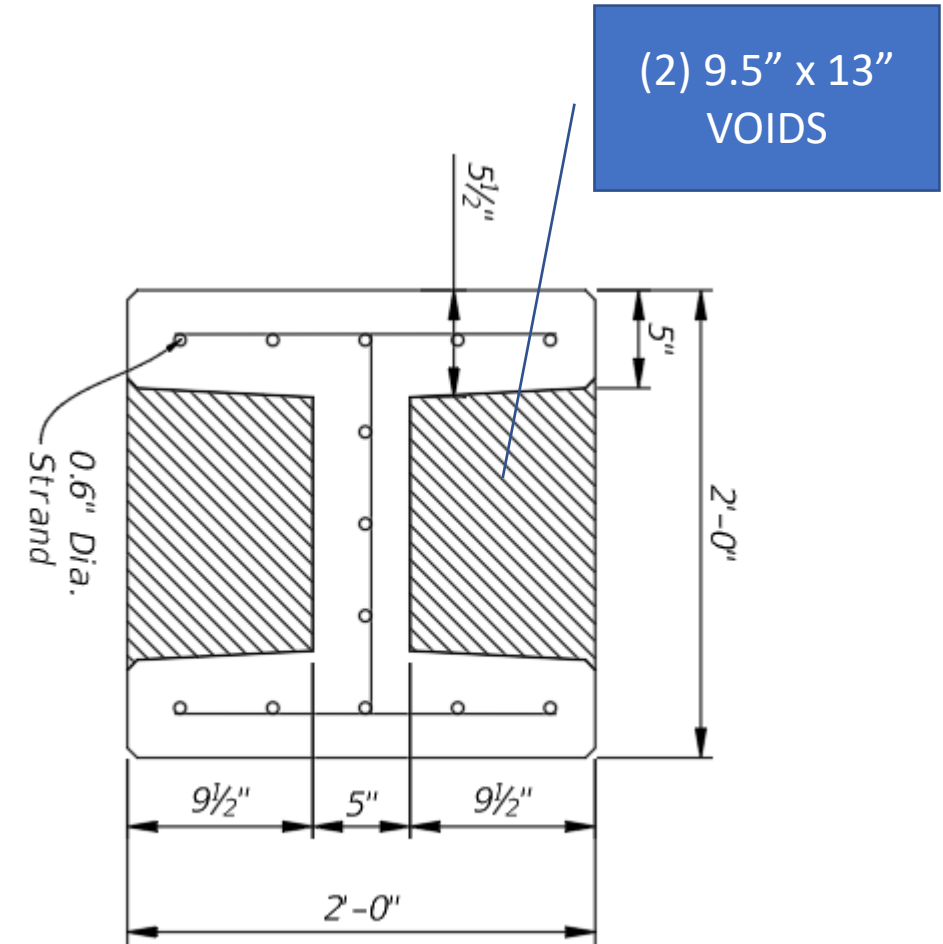

CAST AS AN 'I'

H-PILE STANDARDS

Alabama Style



≠

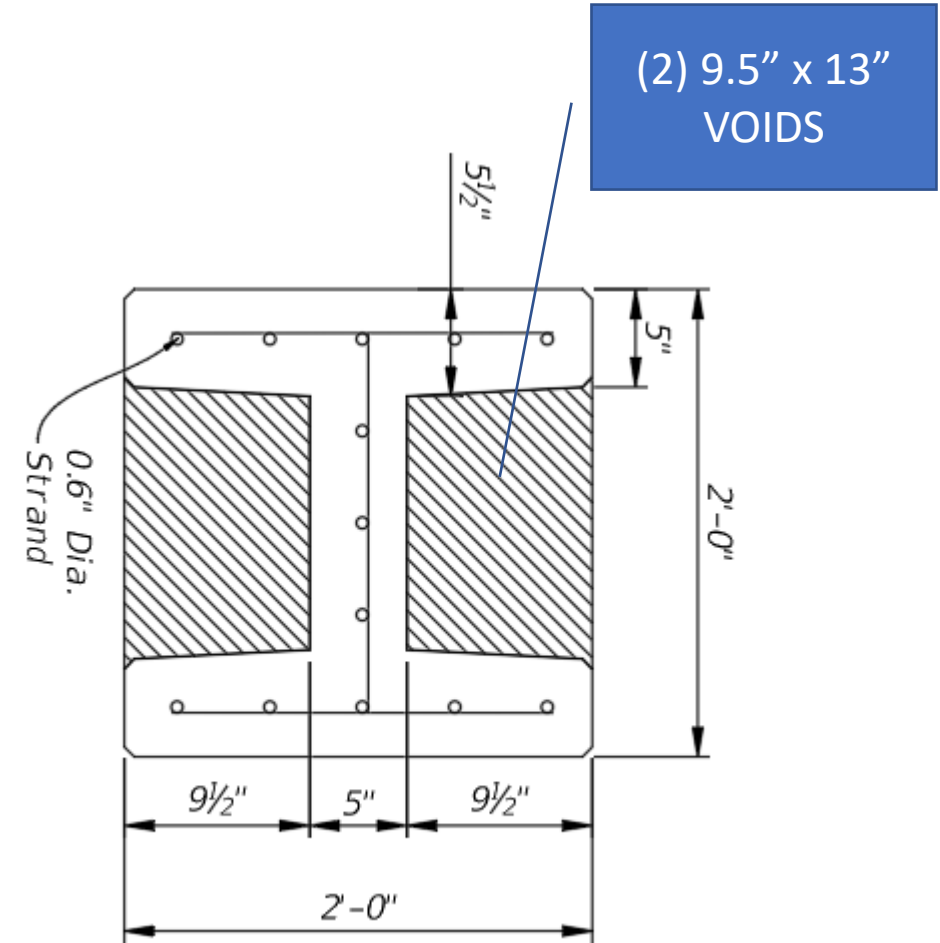

Cast As An 'I'

Similarities to Dr. Aeliti/FACCA H-Shape cast at Standard Concrete Products (Tampa, FL) 10/26/2022.

H-PILE STANDARDS

Alabama Style

[Video](#)



Dr. Aaleti/FACCA H-Shape Casting
(10/26/2022)

FDOT H-PILE STANDARDS

18" x 18"

DRAFT

1st of 3 Standard Pile Sizes

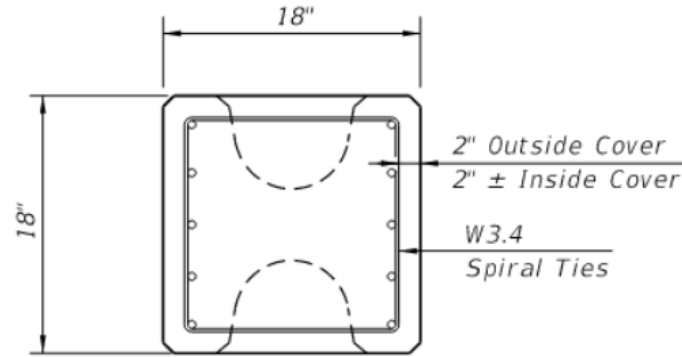

SECTION A-A
(Square Head - Option 1)

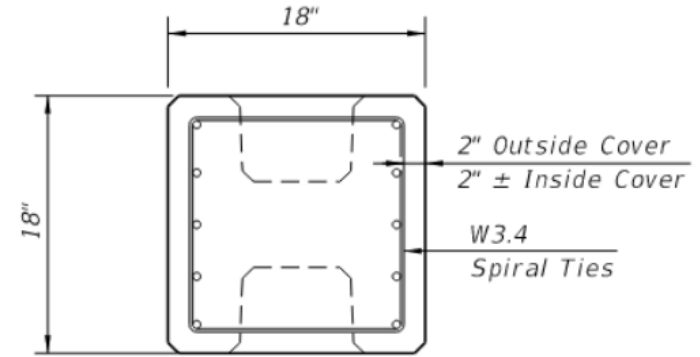

SECTION A-A
(Square Head - Option 2)

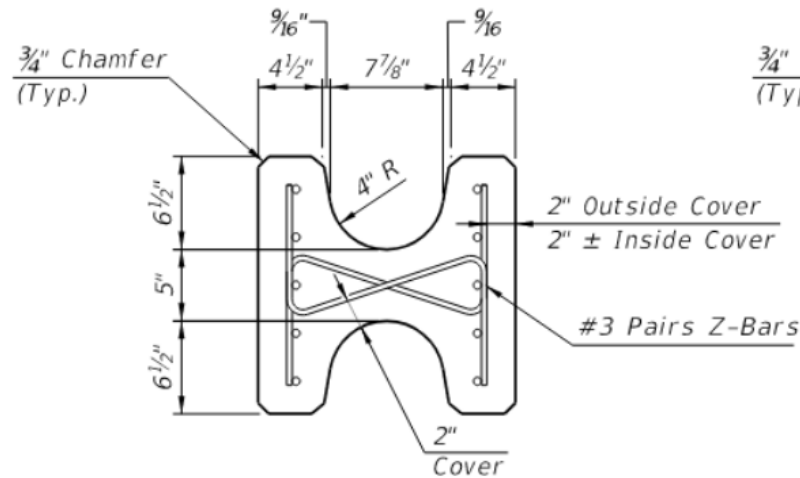

SECTION B-B
(H-Shape - Option 1)

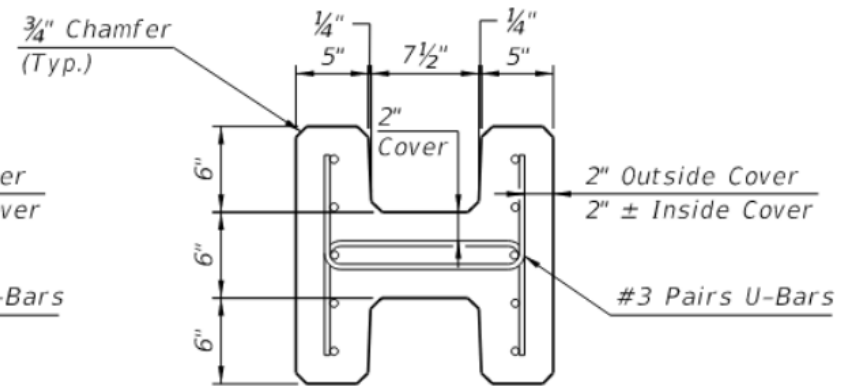

SECTION B-B
(H-Shape - Option 2)

FDOT H-PILE STANDARDS

24" x 24"

DRAFT

2nd of 3 Standard Pile Sizes

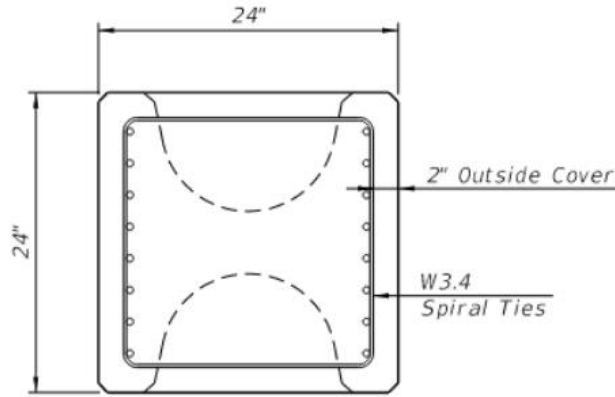

SECTION A-A
(Square Head - Option 1)

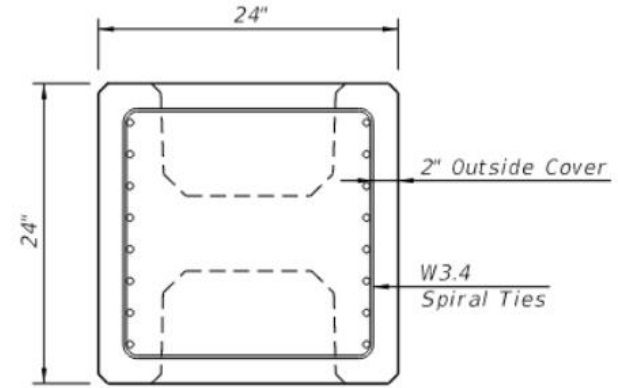

SECTION A-A
(Square Head - Option 2)

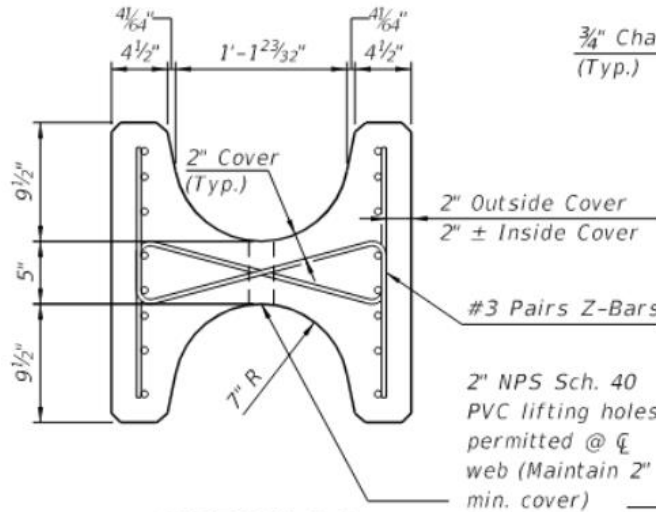

SECTION B-B
(H-Shape - Option 1)

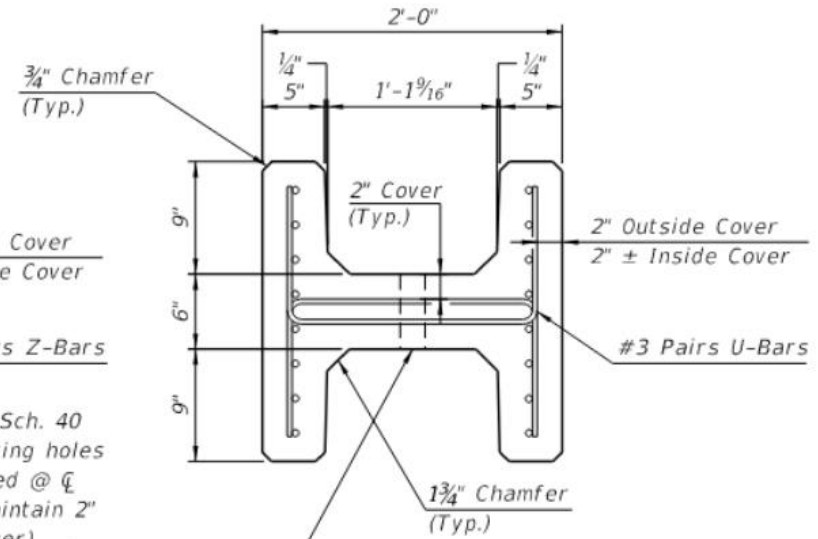

SECTION B-B
(H-Shape - Option 2)

FDOT H-PILE STANDARDS

24" x 24"

DRAFT

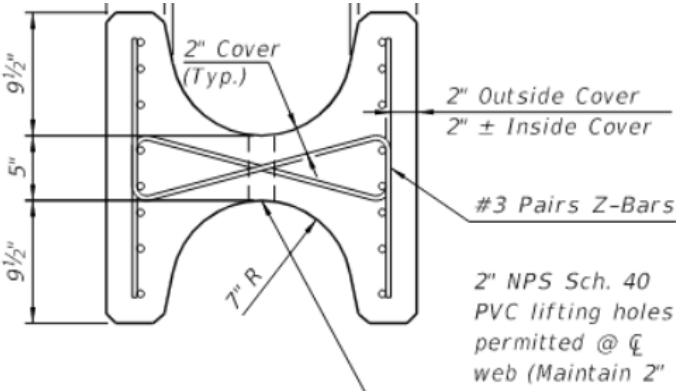

Pile Option 1 - 0.6" Strands

Pile Size	18	24	30
Pile Area (in ²)	231	349.6	473.1
# of Strands	8	10	14
Pull (kip)	44	44	44
f _{pi} (ksi)	202.8	202.8	202.8
Loss at installation	16.7%	15.4%	15.6%
f _{pei} (ksi)	169	171.6	171.2
Comp.Stress (ksi)	1.27	1.07	1.1

24" SQUARE PRESTRESSED CONCRETE PILE INTERACTION DIAGRAM

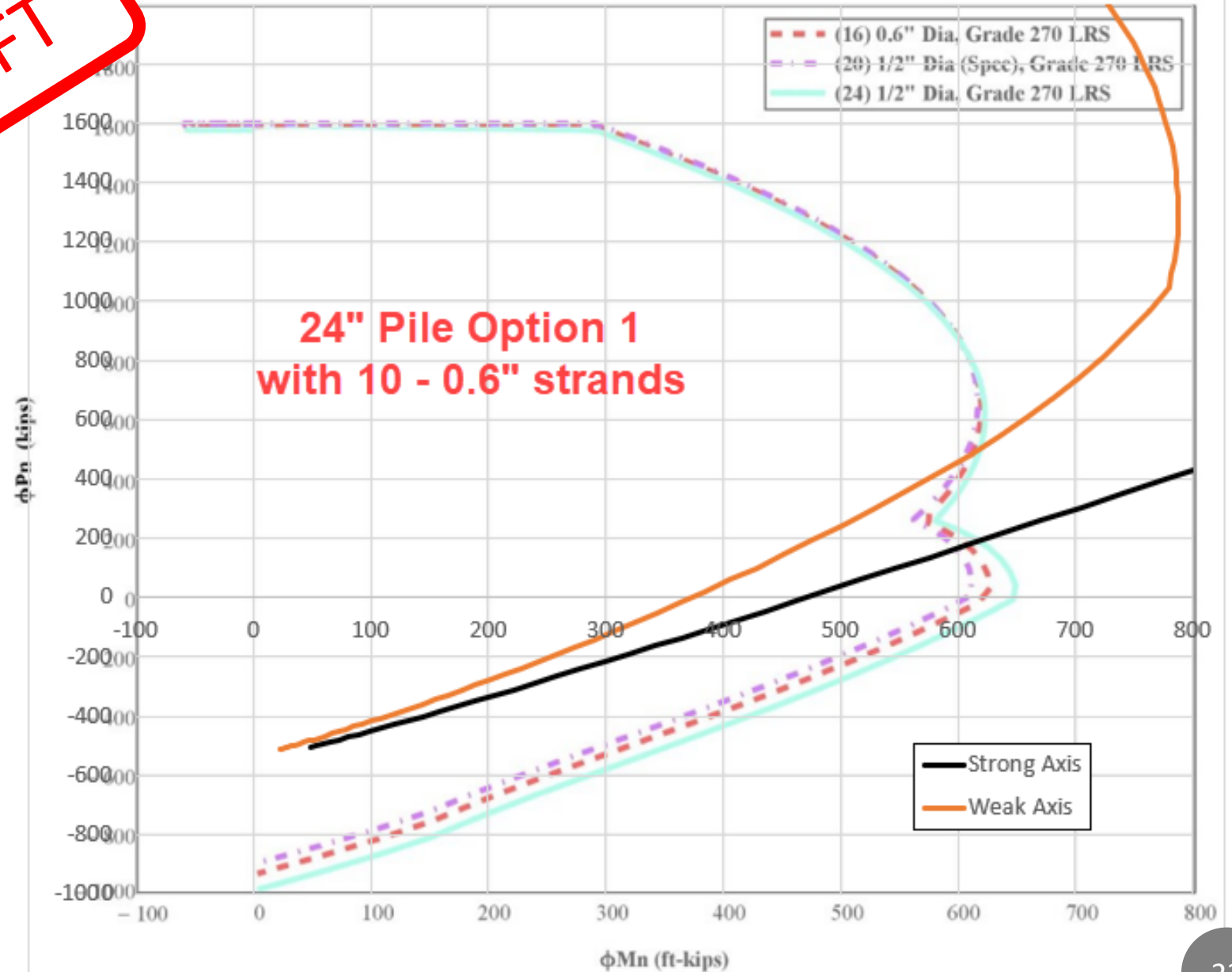

FDOT H-PILE STANDARDS

24" x 24"

DRAFT

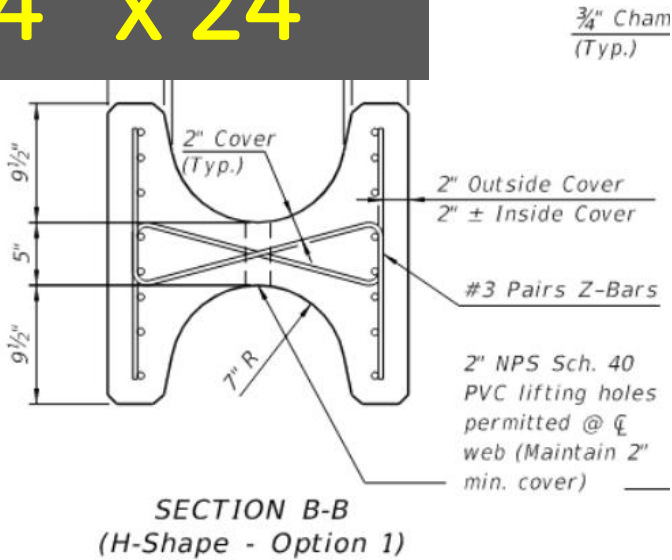

Number of Strands for 1500 psi compression at installation

Pile Size	18	24	30
# of 0.6" Strands	10	16	20
Spacing of Strands (in)	3.35	2.77	2.82
Pull (kip)	43	41	44

24" SQUARE PRESTRESSED CONCRETE PILE INTERACTION DIAGRAM

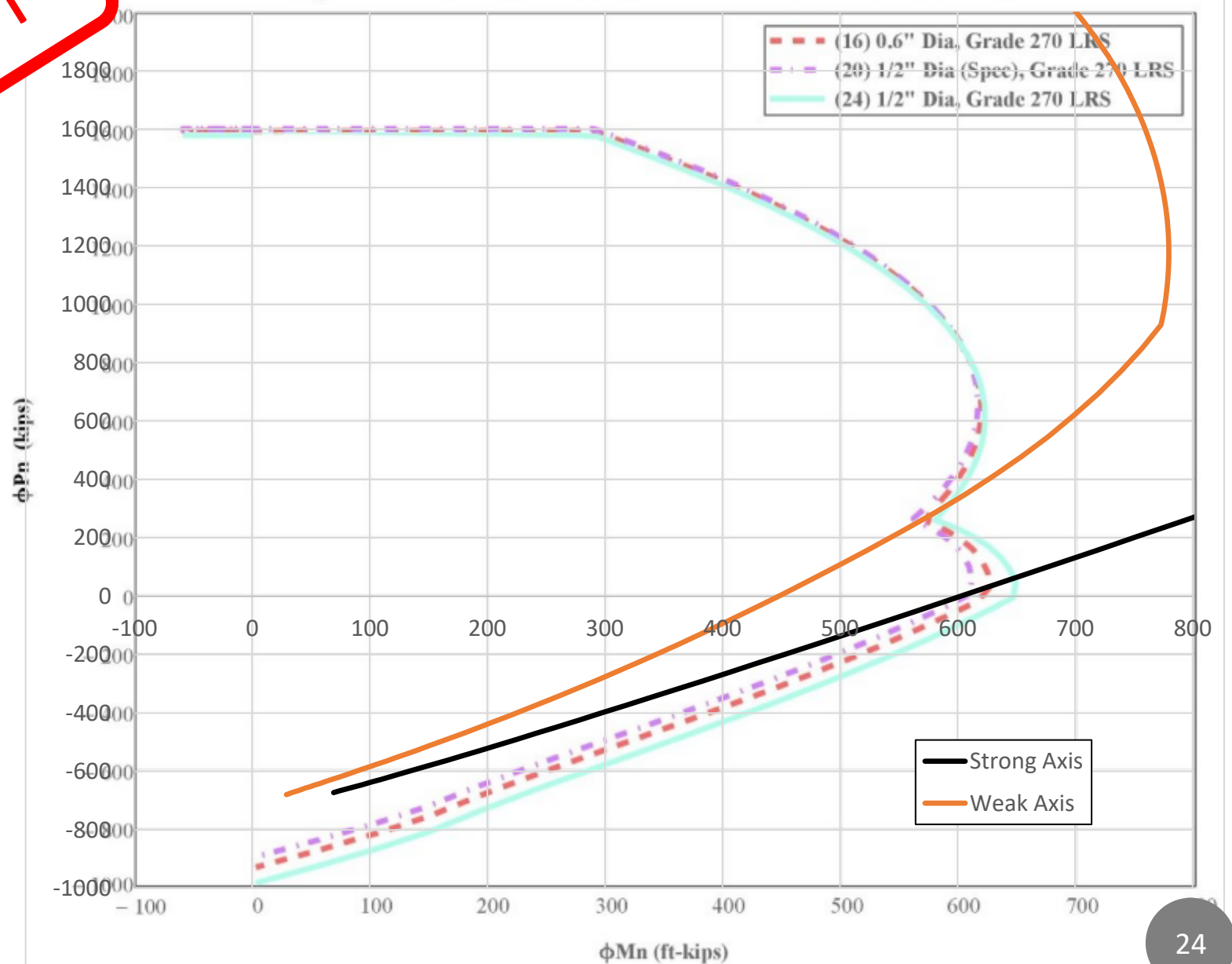

FDOT H-PILE STANDARDS

30" x 30"

3rd of 3 Standard Pile Sizes



DRAFT

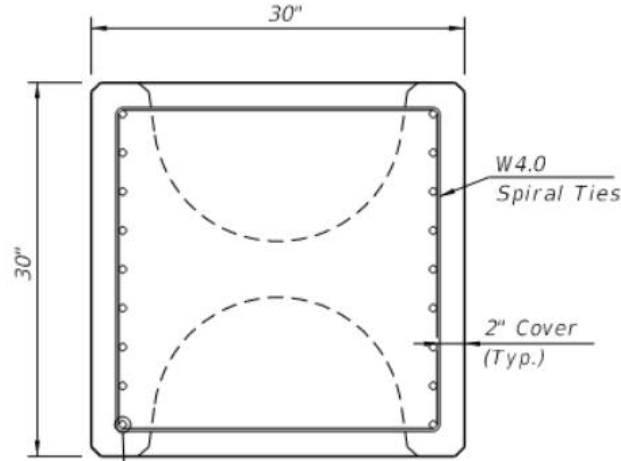

Prestressing Strands, see Alternate Strand Patterns

SECTION C-C (Option 1)
(See Pile Splice Reinforcement Details)

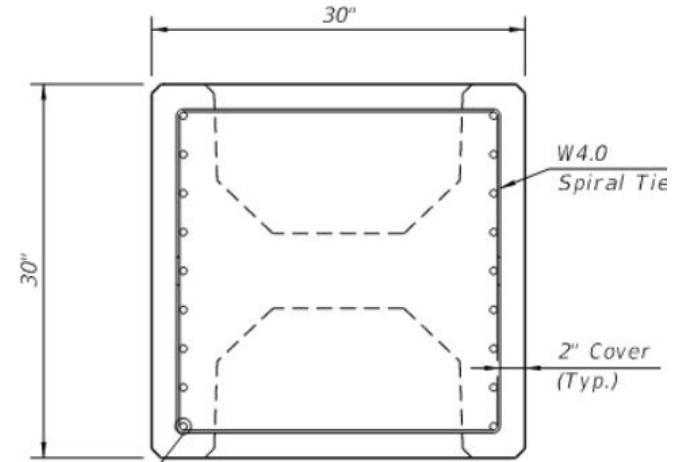

Prestressing Strands, see Alternate Strand Patterns

SECTION C-C (Option 2)
(See Pile Splice Reinforcement Details)

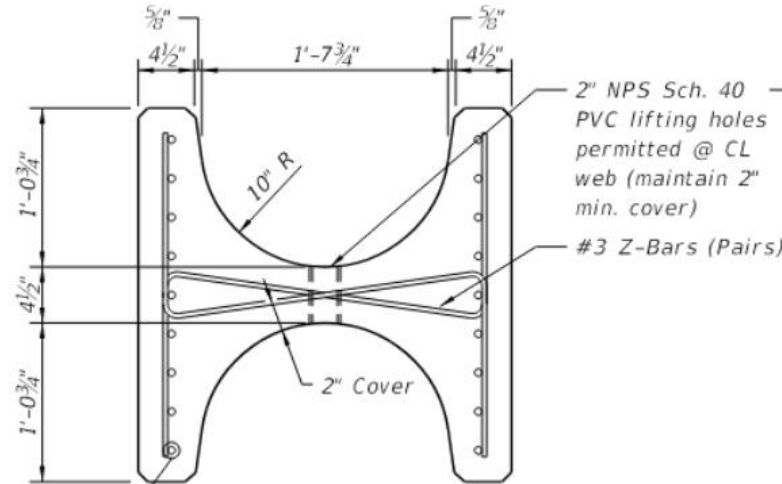

Prestressing Strands, see Alternate Strand Patterns

SECTION B-B (Option 1)
(See Pile Splice Reinforcement Details)

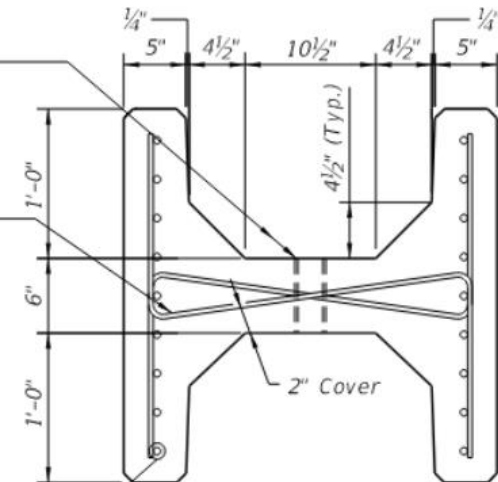

Prestressing Strands, see Alternate Strand Patterns

SECTION B-B (Option 2)
(See Pile Splice Reinforcement Details)



STANDARDIZING UHPC PILES: ACTIVE STEPS...

1. Working on Draft *Standard Plans*
2. Update Material *Specifications (Dev349UHPC & Dev927UHPC)* and *Materials Manual?*
3. Update Construction *Specifications (Section 455- Section B)*
4. Update Design Criteria & *Specifications (AASHTO Guide, SDG Chapter 3, S&FH)*
5. Coordinating with Prestressed Concrete Industry (FPCA, Durastress, Standard Concrete, Gate, etc.)
6. Will meet with Contractors soon.
7. Research...A LOT OF RESEARCH going on!
 - a. FDOT Sponsored
 - b. FHWA/AASHTO
 - c. PCI, etc.

FDOT & AASHTO UHPC Design Guidance

Structures Design / Design Innovation Ultra-High Performance Concrete

Structures Design - Transportation Innovation
Ultra-High Performance Concrete (UHPC)

Overview
Usage Restrictions / Parameters
Design Criteria
Specifications
Approved Products
Projects
FDOT Research
Technology Transfer (T²)
Contact

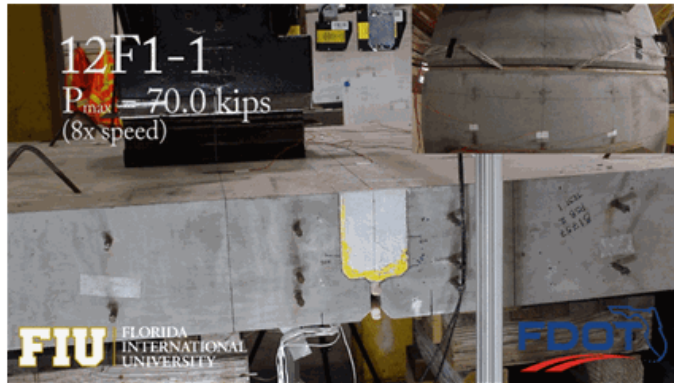

Overview

Ultra High Performance Concrete (UHPC) is part of FHWA's Every Day Counts intended to highlight some advantages of accelerated project delivery and long-term durability minimizing repairs and future disruption to traffic. Both the FHWA and FDOT support the use of accelerated project delivery techniques such as UHPC and Prefabricated Bridge Elements and Systems (PBES) as an economical way to increase quality, reduce long-term maintenance costs and construction time, which indirectly supports safety. Use of these innovative concepts aids in solving many constructability and durability challenges, while potentially revolutionizing bridge construction in the United States.

<http://www.fdot.gov/structures/innovation/UHPC.shtm>

September 2023

- FDOT [Developmental Spec 349 & 927](#);
- Transportation Pooled Fund [1434/TPF-5\(366\)](#);
- FHWA *Guide Specification Development* → **AASHTO Guide Spec.** (CBS Approved in May 2023. Publication Pending)

Development of a UHPC Guide Spec

Ben Graybeal, Ph.D., P.E., Federal Highway Administration,
benjamin.graybeal@dot.gov, (202)493-3122

Rafic G. El Helou, Ph.D., NRC Associate at FHWA-TFHC,
rafic.elhelou.ctr@dot.gov, (202)493-3482

TRB Concrete Bridges Committee
January 15, 2019 – Washington, DC

Proposed Draft Version of
AASHTO LRFD GUIDE SPECIFICATION
FOR
STRUCTURAL DESIGN WITH ULTRA-HIGH PERFORMANCE CONCRETE

TABLE OF CONTENTS

SECTION 1. STRUCTURAL DESIGN	1
1.1. SCOPE	1
1.1.1. General	1
1.1.2. Design Philosophy	3
1.1.3. Load and Load Combination	4
1.1.4. Limitations	4
1.2. DEFINITIONS	5
1.3. NOTATION	10
1.4. MATERIAL PROPERTIES	15
1.4.1. General	15
1.4.2. Ultra-High-Performance Concrete	15
1.4.2.1. General	15
1.4.2.2. Ultimate Weight	16
1.4.2.3. Modulus of Elasticity	17
1.4.2.4. Compression Behavior	17
1.4.2.5. Tension Behavior	19
1.4.2.6. Poisson's Ratio	21
1.4.2.7. Coefficient of Thermal Expansion	21
1.4.2.8. Creep and Shrinkage	21
1.4.3. Reinforcing Steel	21
1.4.4. Prestressing Steel	21



QUESTIONS & DISCUSSION

