

ITEM	PART NUMBER	DRAWING	DESCRIPTION	MATERIAL
1	71014	SDI-HD-190	SDI 31.6 ANCHOR HEAD	ASTM A 536 GR. 80-55-06
2	72013	SDI-HD-115	SDI 31.6-PC BEARING PLATE	ASTM A 536 GR. 80-55-06 (GALVANIZED)
3	76008	SDI-HD-236	O-RING SEAL	BUNA-N PER ASTM D2240, & D412
4	73007	SDI-HD-179	SDI 31.6 TRUMPET	HIGH DENSITY POLYETHYLENE PER ASTM D3350
5	74017	SDI-HD-165	STANDARD 31.6-PC SPIRAL	GRADE 60 STEEL PER ASTM A815
6	75009	SDI-HD-116	SDI 31.6-PC PERMANENT GROUT CAP	NYLON PER ASTM D5989
7	76002	SDI-HD-236	O-RING SEAL	BUNA-N PER ASTM D2240, & D412
8	77009	SDI-HD-151	(6) 1/2" x 3.5" BOLTS & WASHERS	STAINLESS STEEL, TYPE 316
9	76022	SDI-HD-236	O-RING SEAL	BUNA-N PER ASTM D2240, & D412
10	21001	SDI-HD-148	0.6" STRAND	270KSI STEEL PER ASTM A416, LOW RELAXATION
11	81001	SDI-HD-021	SDI 0.6" STANDARD 2-PART WEDGE	AISI 11L17 OR 12L14
12	52010	SDI-HD-337	1/2" NPT BALL VALVE (TEMPORARY)	BRASS
13	52009	SDI-HD-271	1" NPT BALL VALVE (TEMPORARY)	BRASS
14	52010	SDI-HD-272	3/4" NPT BALL VALVE (TEMPORARY)	BRASS
15	53013	SDI-HD-366	1" NPT FEMALE TO MALE 90° ELBOW	STEEL PER ASTM A53
16	33007	SDI-HD-216	5" (128mm) SLIP-ON DUCT COUPLER	POLYPROPYLENE PER ASTM D4101
17	37008	SDI-HD-367	KLNN HEAT SHRINK TUBING	ADHESIVE LINED POLYOLEFIN
18	33131	SDI-HD-226	SDI 5" COUPLER SLIDE HOUSING	POLYPROPYLENE PER ASTM D4101
19	33133	SDI-HD-229	SDI 5" COUPLER SEAL	BUNA-N PER ASTM D2240, & D412
20	33130	SDI-HD-225	SDI 5" COUPLER WELDED HOUSING	POLYPROPYLENE PER ASTM D4101
21	35005	SDI-HD-182	5" ID (128mm) HDPE PIPE	HIGH DENSITY POLYETHYLENE PER ASTM D2513, F1055
22	55004	SDI-HD-257	SDI GROUT PORT PLUG	POLYPROPYLENE PER ASTM D4101
23	57004	SDI-HD-172	3/4" NPT WELDABLE GROUT PORT	HIGH DENSITY POLYETHYLENE PER ASTM D2513, F1055
24	53011	SDI-HD-222	1/2" (13mm) NPT COUPLER (TEMPORARY)	POLYPROPYLENE PER ASTM D4101
25	55022	SDI-HD-360	1/2" NPT CAP	POLYPROPYLENE PER ASTM D4101
26	55001	SDI-HD-156	3/4" (23mm) PLUG	POLYPROPYLENE PER ASTM D4101
27	53014	SDI-HD-365	1/2" NPT MALE BARBED HOSE ADAPTOR (TEMPORARY)	BRASS
28	59001	SDI-HD-364	CLEAR HIGH TEMP. VACUUM TUBE (TEMPORARY)	FLUORINATED ETHYLENE PROPYLENE
29	33404	SDI-HD-374	ELECTRO-FUSION COUPLER DR-17	HIGH DENSITY POLYETHYLENE PER ASTM D2513, F1055
30	51003	SDI-HD-269	1" NPT PIPE NIPPLE (TEMPORARY)	STEEL PER ASTM A53
31	51005	SDI-HD-363	3/4" NPT PIPE NIPPLE (TEMPORARY)	STEEL PER ASTM A53
32	0000T	N/A	TEFLON TAPE (TEMPORARY)	TEFLON
33	0000G	N/A	COMMERCIALY AVAILABLE/COMPATIBLE LITHIUM GREASE	LITHIUM
34	0000E	N/A	COMMERCIALY AVAILABLE/COMPATIBLE EPOXY	EPOXY

* ALL NON-FERROUS COMPONENTS CONTAIN VIRGIN MATERIAL.

STEP-BY-STEP SYSTEM INSTALLATION PROCEDURE

- STEP 1: HANG BEARING PLATE WITH 2 EACH 1/2" ALL THREAD. PLACE SO GROUT PORT IS IN 11 O'CLOCK OR 12 O'CLOCK POSITION.
- STEP 2: PLACE O-RING IN LARGE CORRUGATION OF TRUMPET. (SEE NOTE: a)
- STEP 3: TURN TRUMPET INTO BEARING PLATE AND ENSURE GROUT PORT HOLES LINE UP. USE STRAP WRENCH IF NECESSARY.
- STEP 4: HANG SPIRAL 1" BEHIND BEARING PLATE. ENSURE SPIRAL IS CONCENTRIC AND PARALLEL TO PATH OF TENDON.
- STEP 5: CONNECT PIPE TO TRUMPET.
IF USING SLIP COUPLER FOR CONNECTION:
1. SLIDE SLIP COUPLER OVER TRUMPET AND DUCT.
2. INSTALL CORRECT SIZE AND LENGTH OF HEAT SHRINK PER MANUFACTURER'S RECOMMENDATIONS.
- STEP 7: PERFORM VACUUM TEST PER FDOT 462-8.2.1.2
- STEP 8: INSTALL STRAND, LEAVE SUFFICIENT STRAND FOR STRESSING EQUIPMENT.
- STEP 9: PLACE ANCHOR HEAD ENSURE ANCHOR HEAD WEDGE CAVITIES ARE RUST FREE AND CLEAN PRIOR TO WEDGE INSTALLATION.
- STEP 10: ALIGN ANCHOR HEAD SO THAT TAPPED HOLE IS IN 1 O'CLOCK POSITION. AVOID CROSSING STRANDS.
- STEP 11: PUSH WEDGES OVER STRAND AND AGAINST INTO THE ANCHOR HEAD WEDGE CAVITIES USING A 3/4" PIPE.
- STEP 12: STRESS TENDONS AFTER CONCRETE HAS REACHED REQUIRED STRENGTH PER DRAWINGS AND/OR SPECIFICATION.
- STEP 13: AFTER STRESSING AND APPROVAL FROM OWNERS REPRESENTATIVE, CUT STRAND TAILS 1" FROM FACE OF ANCHOR HEAD.
- STEP 14: INSTALL VENTS. (SEE NOTE b)
- STEP 15: INSTALL PERMANENT CAP BY TORQUEING BOLTS IN A STAR PATTERN TO 20 FT-LB. (SEE NOTE c)
- STEP 16: PERFORM PRESSURE TEST PER FDOT 462-8.2.1.2
- STEP 17: INSTALL TEMPORARY WAX INJECTION HARDWARE.
- STEP 18: INJECT WAX PER WAX INJECTION PROCEDURE.
- STEP 19: REMOVE ALL TEMPORARY HARDWARE ONCE WAXING PROCEDURE IS COMPLETE AND CAP OR PLUG PORTS PER DRAWINGS.

NOTES:

- a. LUBRICATE ALL O-RINGS FOR EASE OF INSTALLATION.
- b. EPOXY IS TO BE USED ON EVERY PERMANENT GROUT HOSE/COUPLER/PLUG THREADS, TEFLON TAPE IS TO BE USED ON EVERY TEMPORARY GROUT HOSE/COUPLER/PLUG THREADS. THREAD INTO ALL CONNECTIONS. DO NOT INJECT THROUGH VENTS.
- c. MAKE SURE O-RING AND WASHER IS INSTALLED WITH GROUT CAP BOLT.
- d. VENTS SHOWN FOR REFERENCE ONLY. FOR ACTUAL LOCATION, SEE PLACING DRAWINGS. VENT CAN BE ORIENTED TO ACT AS DRAIN.
- e. SEE SEGMENT COUPLER INSTALLATION PLAN FOR PARTS AND ASSEMBLY INFORMATION.
- f. FOLLOW BUTT FUSION PROCEDURE FOR ALL BUTT JOINTS PER MANUFACTURER'S INSTALLATION PROCEDURE.
- g. STEP-BY-STEP INSTALLATION PROCEDURE ARE GENERIC, FOLLOW FDOT AND PROJECT SPECIFICATION REQUIREMENTS. REFERENCE FDOT STANDARD PLANS 462-003 FOR POST-TENSIONING ANCHORAGE AND TENDON FILLING DETAIL.
- h. TENDON FILLER MATERIAL IS WAX.
- i. PERMANENT CAP AND ASSOCIATED HARDWARE ARE FOR VENTING ONLY. DO NOT INJECT THROUGH PERMANENT CAP.

THESE DRAWINGS CONTAIN PROPRIETARY INFORMATION RESTRICTED SOLELY FOR USE ON THIS PROJECT. THESE DRAWINGS MAY NOT BE REPRODUCED IN WHOLE OR IN PART, FOR ANY OTHER USE WITHOUT THE EXPRESSED WRITTEN PERMISSION OF SCHWAGER DAVIS INC. (SDI). SDI DOES NOT MAKE ANY JUDGMENT NOR WARRANTY, EXPRESSED OR IMPLIED, AS TO THE ADEQUACY OF THE STRUCTURAL DESIGN BY OTHERS AND HEREBY DISCLAIMS ANY LIABILITY FOR DESIGNS OF OTHERS.

SCHWAGER DAVIS, INC.

DESIGN-BUILD CONTRACTOR
198 HILLSDALE AVENUE
SAN JOSE, CA 95136
PHONE: 408.281.9300
FAX: 408.281.9301
www.schwagerdavis.com



SCHWAGER DAVIS INC.

SDI 31.6-PC EXTERNAL UNBONDED FLEXIBLE FILLER SYSTEM

SCHWAGER DAVIS, INC.
POST-TENSION SYSTEM LIBRARY

DRAWING No: SDI-HD-355

#	REVISIONS	DRAWN	CHECKED	APPROVED	DATE
0	RELEASE	JSA	MSC	MSC	8/22/18

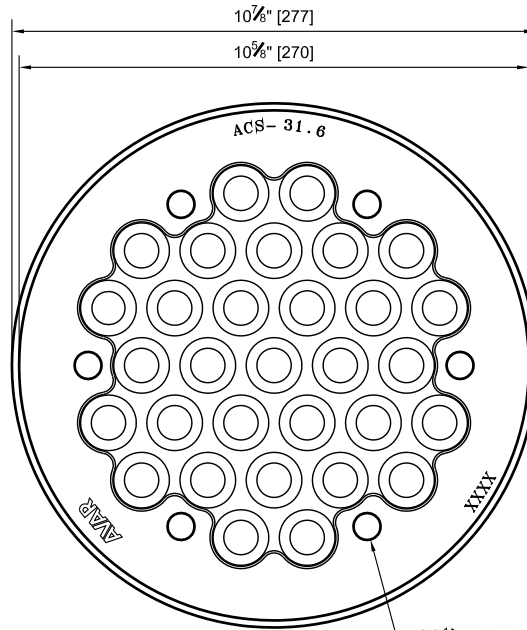

(6) 1/2" - 13 x 1" DEEP
BOLT HOLES EQUALLY
SPACED ON 7 3/4" B.C.

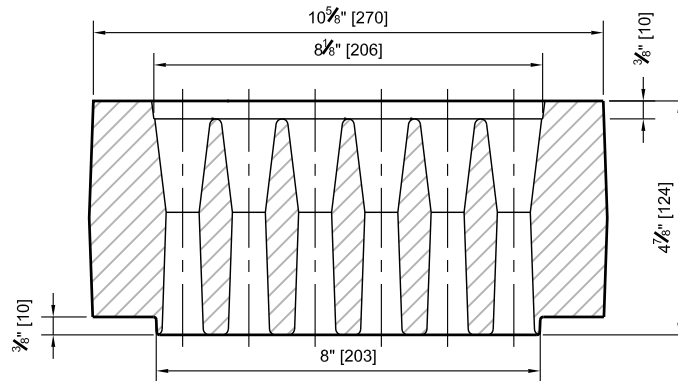

ACS 31.6 ANCHOR HEAD

PART NO.: 71014
MATERIAL: ASTM A 536 GR. 80-55-06
MATERIAL MEETS ALL SPECIFICATIONS.
SCALE: 3" = 1'-0"

THESE DRAWINGS CONTAIN PROPRIETARY INFORMATION RESTRICTED SOLELY FOR USE ON THIS PROJECT. THESE DRAWINGS MAY NOT BE REPRODUCED IN WHOLE OR IN PART, FOR ANY OTHER USE WITHOUT THE EXPRESSED WRITTEN PERMISSION OF SCHWAGER DAVIS INC. (SDI). SDI DOES NOT MAKE ANY JUDGMENT NOR WARRANTY, EXPRESSED OR IMPLIED, AS TO THE ADEQUACY OF THE STRUCTURAL DESIGN BY OTHERS AND HEREBY DISCLAIMS ANY LIABILITY FOR DESIGNS OF OTHERS.

<p>ACS 31.6 ANCHOR HEAD</p>		<p>SCHWAGER DAVIS, INC. DESIGN-BUILD CONTRACTOR 198 HILLSDALE AVENUE SAN JOSE, CA 95136 PHONE: 408.281.9300 FAX: 408.281.9301 www.schwagerdavis.com</p>	<p>DRAWING No: SDI-HD-190</p> <table border="1" style="width: 100%; border-collapse: collapse;"> <thead> <tr> <th>#</th> <th>REVISIONS</th> <th>DRAWN</th> <th>CHECKED</th> <th>APPROVED</th> <th>DATE</th> </tr> </thead> <tbody> <tr> <td>0</td> <td>RELEASE</td> <td>MHA</td> <td>MSC</td> <td>MSC</td> <td>05/02/14</td> </tr> <tr> <td>1</td> <td>UPDATE</td> <td>CSM</td> <td>MSC</td> <td>MSC</td> <td>05/26/15</td> </tr> <tr> <td>2</td> <td>PER COMMENTS</td> <td>MHA</td> <td>JMY</td> <td>MSC</td> <td>07/20/15</td> </tr> <tr> <td> </td> <td> </td> <td> </td> <td> </td> <td> </td> <td> </td> </tr> </tbody> </table>	#	REVISIONS	DRAWN	CHECKED	APPROVED	DATE	0	RELEASE	MHA	MSC	MSC	05/02/14	1	UPDATE	CSM	MSC	MSC	05/26/15	2	PER COMMENTS	MHA	JMY	MSC	07/20/15						
#	REVISIONS	DRAWN	CHECKED	APPROVED	DATE																												
0	RELEASE	MHA	MSC	MSC	05/02/14																												
1	UPDATE	CSM	MSC	MSC	05/26/15																												
2	PER COMMENTS	MHA	JMY	MSC	07/20/15																												
<p>SCHWAGER DAVIS, INC. POST-TENSION SYSTEM LIBRARY</p>	<p>SCHWAGER DAVIS INC.</p>																																

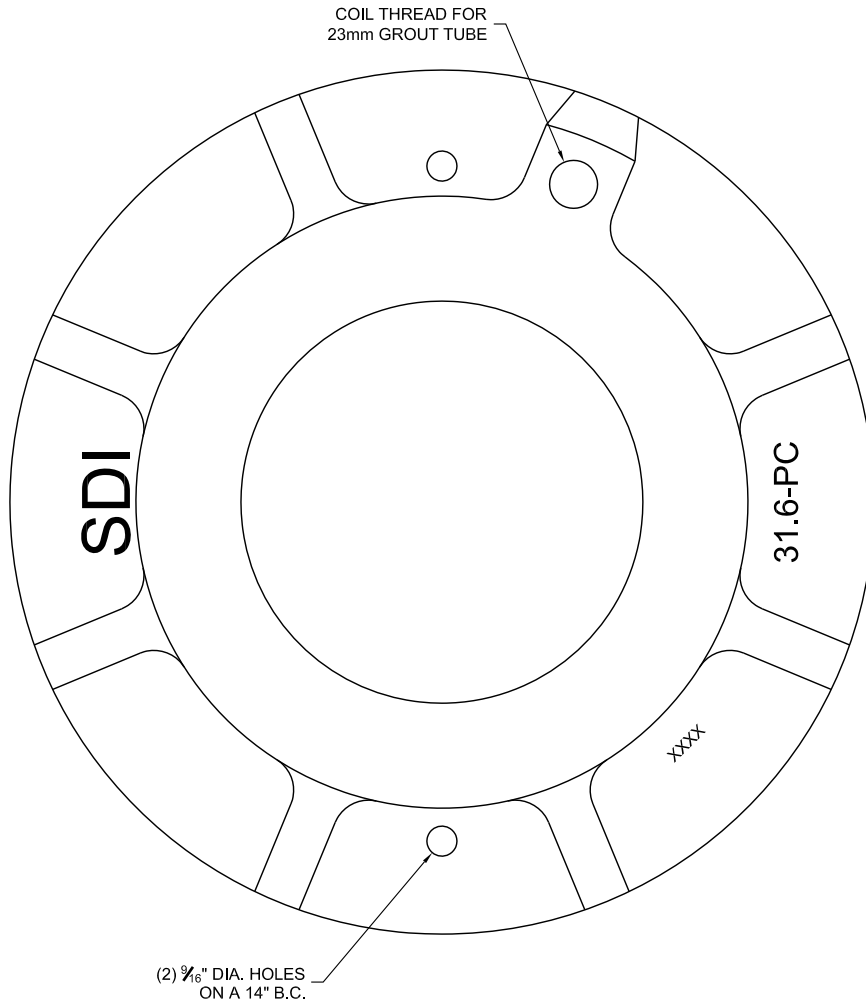
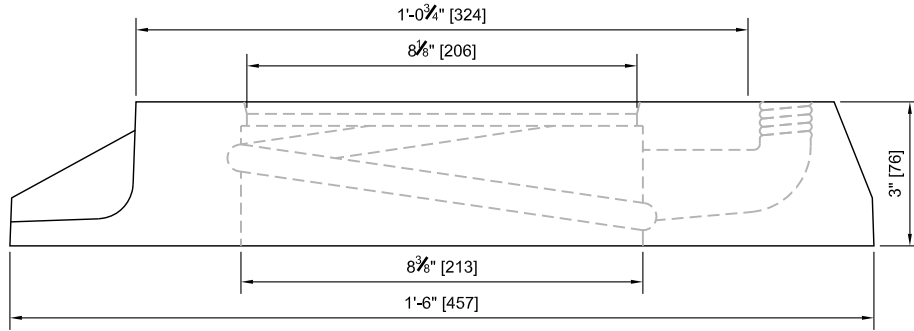

SDI 31.6-PC BEARING PLATE

PART NO.: 72013
 MATERIAL: ASTM A 536 GR. 80-55-06
 MATERIAL MEETS ALL SPECIFICATIONS.
 SCALE: 3" = 1'-0"

THESE DRAWINGS CONTAIN PROPRIETARY INFORMATION RESTRICTED SOLELY FOR USE ON THIS PROJECT. THESE DRAWINGS MAY NOT BE REPRODUCED IN WHOLE OR IN PART, FOR ANY OTHER USE WITHOUT THE EXPRESSED WRITTEN PERMISSION OF SCHWAGER DAVIS INC. (SDI). SDI DOES NOT MAKE ANY JUDGMENT NOR WARRANTY, EXPRESSED OR IMPLIED, AS TO THE ADEQUACY OF THE STRUCTURAL DESIGN BY OTHERS AND HEREBY DISCLAIMS ANY LIABILITY FOR DESIGNS OF OTHERS.

SDI 31.6-PC BEARING PLATE

SCHWAGER DAVIS, INC.
 POST-TENSION SYSTEM LIBRARY



SCHWAGER DAVIS, INC.
 DESIGN-BUILD CONTRACTOR
 198 HILLSDALE AVENUE
 SAN JOSE, CA 95136
 PHONE: 408.281.9300
 FAX: 408.281.9301
 www.schwagerdavis.com

DRAWING No: SDI-HD-115					
#	REVISIONS	DRAWN	CHECKED	APPROVED	DATE
0	RELEASE	MT	MW	MT	07/23/13
1	UPDATE	CSM	MSC	MSC	05/26/15
2	PER COMMENTS	MHA	JMY	MSC	07/20/15

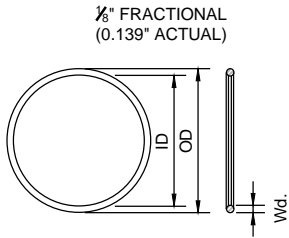

1/8" FRACTIONAL
(0.139" ACTUAL)

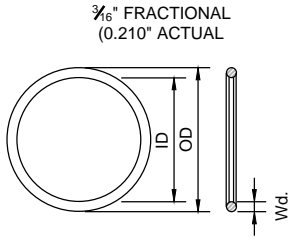

3/16" FRACTIONAL
(0.210" ACTUAL)

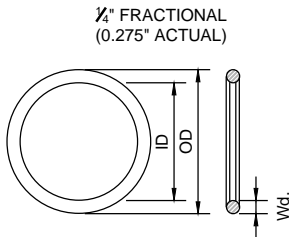

1/4" FRACTIONAL
(0.275" ACTUAL)

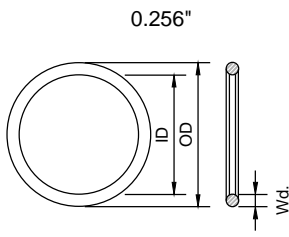

0.256"

PART NO.	DASH NO.	FRACTIONAL SIZE, ID x OD	ACTUAL SIZE ID x OD	WIDTH	DUROMETER
76022	2-204	3/8" x 5/8"	0.359" x 0.637"	1/8" FRACTIONAL (0.139" ACTUAL)	70
76023	2-206	1/2" x 3/4"	0.484" x 0.762"	1/8" FRACTIONAL (0.139" ACTUAL)	70
76019	2-339	3/4" x 35/64"	3.225" x 3.645"	3/16" FRACTIONAL (0.210" ACTUAL)	70
76014	2-407	23/4" x 23/4"	2.225" x 2.775"	1/4" FRACTIONAL (0.275" ACTUAL)	70
76016	2-415	3/4" x 33/4"	3.225" x 3.775"	1/4" FRACTIONAL (0.275" ACTUAL)	70
76017	2-422	45/8" x 45/8"	4.100" x 4.650"	1/4" FRACTIONAL (0.275" ACTUAL)	70
76018	2-427	43/4" x 51/4"	4.725" x 5.275"	1/4" FRACTIONAL (0.275" ACTUAL)	70
76025	2-432	53/8" x 53/8"	5.350" x 5.900"	1/4" FRACTIONAL (0.275" ACTUAL)	70
76008	2-435	53/4" x 61/4"	5.725" x 6.275"	1/4" FRACTIONAL (0.275" ACTUAL)	40
76009	2-440	63/4" x 71/4"	6.725" x 7.275"	1/4" FRACTIONAL (0.275" ACTUAL)	40
76010	2-442	71/4" x 73/4"	7.225" x 7.775"	1/4" FRACTIONAL (0.275" ACTUAL)	40
76002	2-444	73/4" x 83/4"	7.725" x 8.275"	1/4" FRACTIONAL (0.275" ACTUAL)	70
76011	2-445	8" x 81/2"	7.975" x 8.525"	1/4" FRACTIONAL (0.275" ACTUAL)	40
76026	2-446	81/2" x 9"	8.475" x 9.025"	1/4" FRACTIONAL (0.275" ACTUAL)	40
76004	2-448	91/2" x 10"	9.475" x 10.025"	1/4" FRACTIONAL (0.275" ACTUAL)	70
76024	2-452	111/2" x 12"	11.475" x 12.025"	1/4" FRACTIONAL (0.275" ACTUAL)	70
76003	CUSTOM	-	8.747" x 9.259"	0.256"	70
76005	CUSTOM	-	10.226" x 10.738"	0.256"	70
76029	2-228	21/4" x 21/2"	2.250" x 2.500"	9/64" FRACTIONAL (0.139" ACTUAL)	70
76030	2-425	41/2" x 5"	4.475" x 5"	1/4" FRACTIONAL (0.275" ACTUAL)	70

STANDARD O-RINGS

MATERIAL: BUNA-N
MATERIAL MEETS ALL SPECIFICATIONS.

THESE DRAWINGS CONTAIN PROPRIETARY INFORMATION RESTRICTED SOLELY FOR USE ON THIS PROJECT. THESE DRAWINGS MAY NOT BE REPRODUCED IN WHOLE OR IN PART, FOR ANY OTHER USE WITHOUT THE EXPRESSED WRITTEN PERMISSION OF SCHWAGER DAVIS INC. (SDI). SDI DOES NOT MAKE ANY JUDGMENT NOR WARRANTY, EXPRESSED OR IMPLIED, AS TO THE ADEQUACY OF THE STRUCTURAL DESIGN BY OTHERS AND HEREBY DISCLAIMS ANY LIABILITY FOR DESIGNS OF OTHERS.

STANDARD O-RINGS

SCHWAGER DAVIS, INC.
POST-TENSION
SYSTEM LIBRARY



SCHWAGER DAVIS, INC.
DESIGN-BUILD CONTRACTOR
198 HILLSDALE AVENUE
SAN JOSE, CA 95136
PHONE: 408.281.9300
FAX: 408.281.9301
www.schwagerdavis.com

DRAWING No: SDI-HD-236

#	REVISIONS	DRAWN	CHECKED	APPROVED	DATE
0	RELEASE	MHA	MSC	MSC	01/15/15
1	UPDATE	CSM	MSC	MSC	05/26/15
2	UPDATE	CSM	MSC	MSC	06/07/16
3	UPDATE	JSA	MSC	MSC	06/20/18

SDI 31.6 TRUMPET

PART NO.: 73007
 MATERIAL: HDPE
 MATERIAL MEETS ALL SPECIFICATIONS.
 SCALE: 3" = 1'-0"

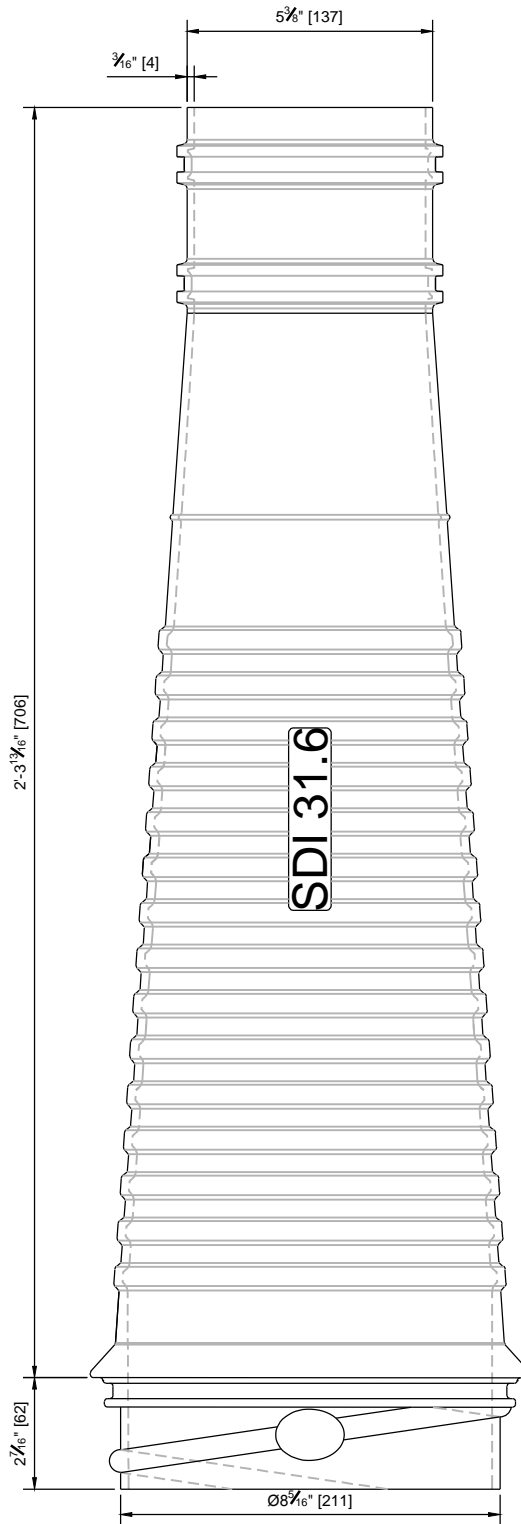

THESE DRAWINGS CONTAIN PROPRIETARY INFORMATION RESTRICTED SOLELY FOR USE ON THIS PROJECT. THESE DRAWINGS MAY NOT BE REPRODUCED IN WHOLE OR IN PART, FOR ANY OTHER USE WITHOUT THE EXPRESSED WRITTEN PERMISSION OF SCHWAGER DAVIS INC. (SDI). SDI DOES NOT MAKE ANY JUDGMENT NOR WARRANTY, EXPRESSED OR IMPLIED, AS TO THE ADEQUACY OF THE STRUCTURAL DESIGN BY OTHERS AND HEREBY DISCLAIMS ANY LIABILITY FOR DESIGNS OF OTHERS.

SDI 31.6 TRUMPET

SCHWAGER DAVIS, INC.
 POST-TENSION
 SYSTEM LIBRARY



SCHWAGER DAVIS, INC.
 DESIGN-BUILD CONTRACTOR
 198 HILLSDALE AVENUE
 SAN JOSE, CA 95136
 PHONE: 408.281.9300
 FAX: 408.281.9301
 www.schwagerdavis.com

DRAWING No: SDI-HD-179

#	REVISIONS	DRAWN	CHECKED	APPROVED	DATE
0	RELEASE	MHA	MSC	MSC	04/03/14
1	UPDATE	CSM	MSC	MSC	05/26/15
2	UPDATE	CSM	MSC	MSC	06/06/16
3	UPDATE	CSM	JSA	MSC	06/14/18

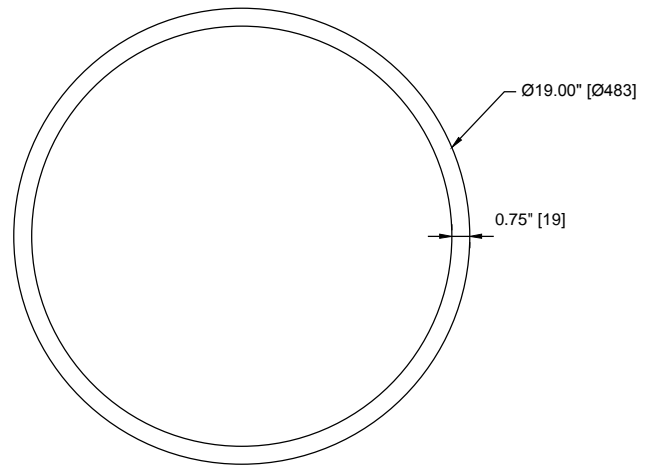
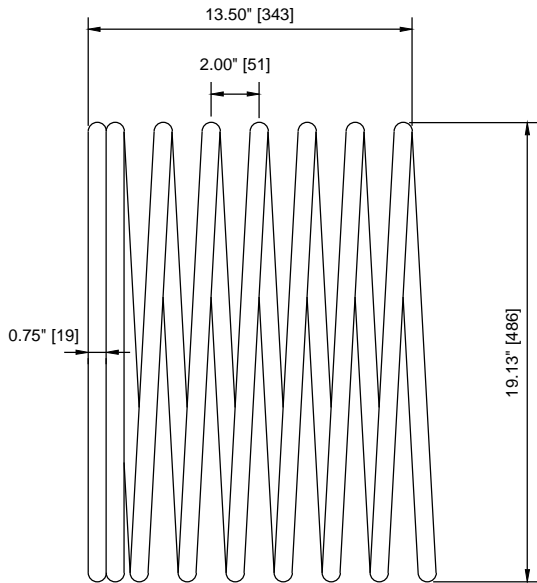
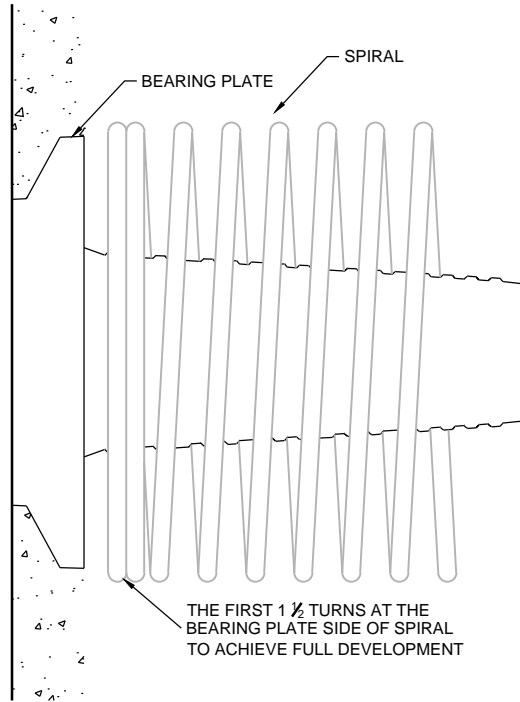

SDI 31.6-PC SPIRAL

PART NO.: 74017
 MATERIAL: GRADE 60 STEEL ACCORDING TO ASTM A615
 #6 REBAR - 19" O.D.
 8 TURNS AT 2" PITCH
 MATERIAL MEETS ALL SPECIFICATIONS.
 SCALE: 1-1/2" = 1'-0"

NOTE: PROJECT SPECIFIC REQUIREMENTS WILL SUPERSEDED
 BURSTING STEEL REQUIREMENTS OF THIS SHEET

THESE DRAWINGS CONTAIN PROPRIETARY INFORMATION RESTRICTED SOLELY FOR USE ON THIS PROJECT. THESE DRAWINGS MAY NOT BE REPRODUCED IN WHOLE OR IN PART, FOR ANY OTHER USE WITHOUT THE EXPRESSED WRITTEN PERMISSION OF SCHWAGER DAVIS INC. (SDI). SDI DOES NOT MAKE ANY JUDGMENT NOR WARRANTY, EXPRESSED OR IMPLIED, AS TO THE ADEQUACY OF THE STRUCTURAL DESIGN BY OTHERS AND HEREBY DISCLAIMS ANY LIABILITY FOR DESIGNS OF OTHERS.

SDI 31.6-PC SPIRAL

SCHWAGER DAVIS, INC.
 POST-TENSION
 SYSTEM LIBRARY



SCHWAGER DAVIS, INC.
 DESIGN-BUILD CONTRACTOR
 198 HILLSDALE AVENUE
 SAN JOSE, CA 95136
 PHONE: 408.281.9300
 FAX: 408.281.9301
 www.schwagerdavis.com

DRAWING No: SDI-HD-165

#	REVISIONS	DRAWN	CHECKED	APPROVED	DATE
0	RELEASE	MHA	MSC	MSC	04/02/14
1	UPDATE	CSM	MSC	MSC	04/20/15
2	UPDATE	CSM	MSC	MSC	06/08/16
3	UPDATE	JSA	MSC	MSC	08/16/18

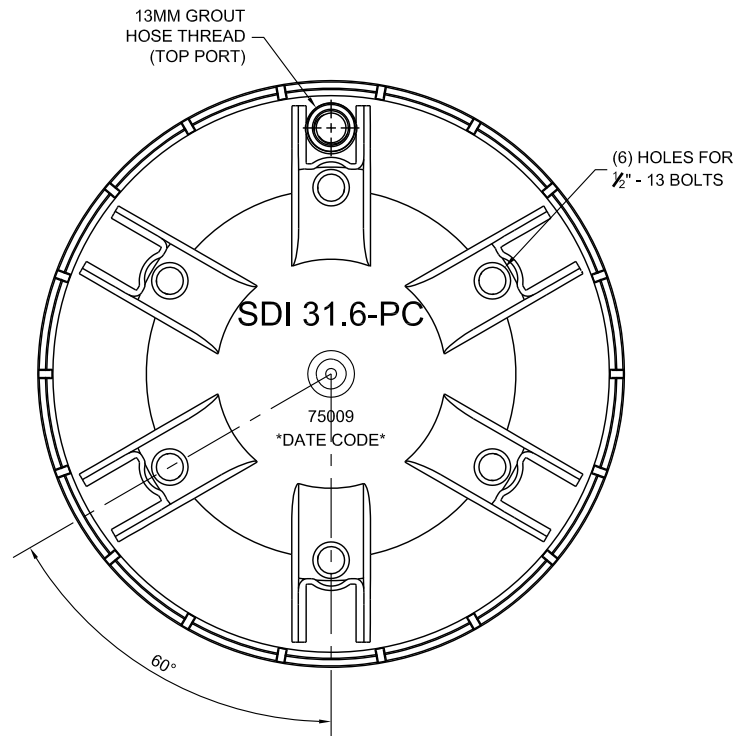
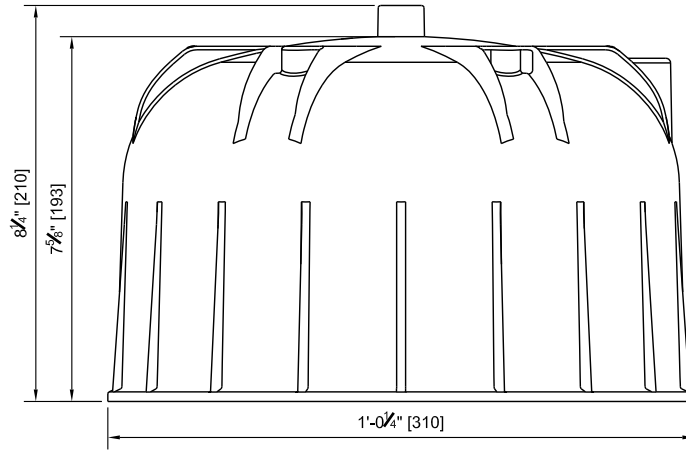

SDI 31.6-PC PERMANENT GROUT CAP

PART NO.: 75009
 MATERIAL: NYLON 66, 30% GLASS FILLED
 MATERIAL MEETS ALL SPECIFICATIONS.
 SCALE: 3" = 1'-0"

THESE DRAWINGS CONTAIN PROPRIETARY INFORMATION RESTRICTED SOLELY FOR USE ON THIS PROJECT. THESE DRAWINGS MAY NOT BE REPRODUCED IN WHOLE OR IN PART, FOR ANY OTHER USE WITHOUT THE EXPRESSED WRITTEN PERMISSION OF SCHWAGER DAVIS INC. (SDI). SDI DOES NOT MAKE ANY JUDGMENT NOR WARRANTY, EXPRESSED OR IMPLIED, AS TO THE ADEQUACY OF THE STRUCTURAL DESIGN BY OTHERS AND HEREBY DISCLAIMS ANY LIABILITY FOR DESIGNS OF OTHERS.

SDI 31.6-PC PERMANENT GROUT CAP

**SCHWAGER DAVIS, INC.
 POST-TENSION SYSTEM LIBRARY**



SCHWAGER DAVIS, INC.
 DESIGN-BUILD CONTRACTOR
 198 HILLSDALE AVENUE
 SAN JOSE, CA 95136
 PHONE: 408.281.9300
 FAX: 408.281.9301
 www.schwagerdavis.com

DRAWING No: SDI-HD-116

#	REVISIONS	DRAWN	CHECKED	APPROVED	DATE
0	RELEASE	MT	MW	MT	07/23/13
1	UPDATE	CSM	MSC	MSC	05/26/15

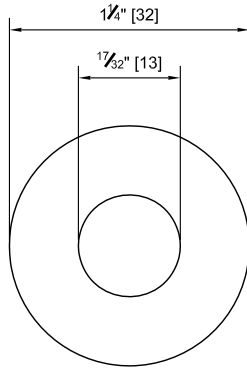

WASHER MAY VARY FROM
0.055" TO 0.069" IN THICKNESS

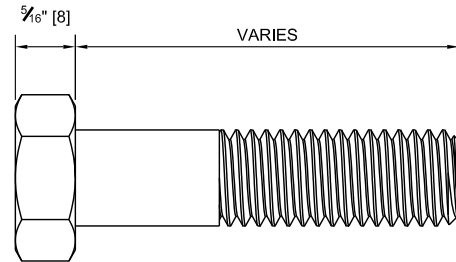
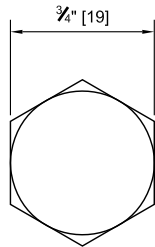

1/2"-13 BOLT & WASHER

PART NO.: 77007 - SDI 27.6-PC PERMANENT CAP BOLTS

77009 - SDI 31.6-PC PERMANENT CAP BOLTS

MATERIAL: STAINLESS STEEL, TYPE 316 ACCORDING TO ASTM F593

MATERIAL MEETS ALL SPECIFICATIONS.

SCALE: 1'-0" = 1'-0"

THESE DRAWINGS CONTAIN PROPRIETARY INFORMATION RESTRICTED SOLELY FOR USE ON THIS PROJECT. THESE DRAWINGS MAY NOT BE REPRODUCED IN WHOLE OR IN PART, FOR ANY OTHER USE WITHOUT THE EXPRESSED WRITTEN PERMISSION OF SCHWAGER DAVIS INC. (SDI). SDI DOES NOT MAKE ANY JUDGMENT NOR WARRANTY, EXPRESSED OR IMPLIED, AS TO THE ADEQUACY OF THE STRUCTURAL DESIGN BY OTHERS AND HEREBY DISCLAIMS ANY LIABILITY FOR DESIGNS OF OTHERS.

1/2"-13 BOLT & WASHER



SCHWAGER DAVIS, INC.
DESIGN-BUILD CONTRACTOR
198 HILLSDALE AVENUE
SAN JOSE, CA 95136
PHONE: 408.281.9300
FAX: 408.281.9301
www.schwagerdavis.com

DRAWING No: SDI-HD-151

#	REVISIONS	DRAWN	CHECKED	APPROVED	DATE
0	RELEASE	MHA	MSC	MSC	04/02/14
1	UPDATE	CSM	MSC	MSC	05/26/15

SCHWAGER DAVIS, INC.
POST-TENSION
SYSTEM LIBRARY

SCHWAGER
DAVIS INC.

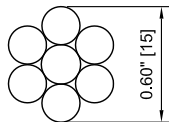
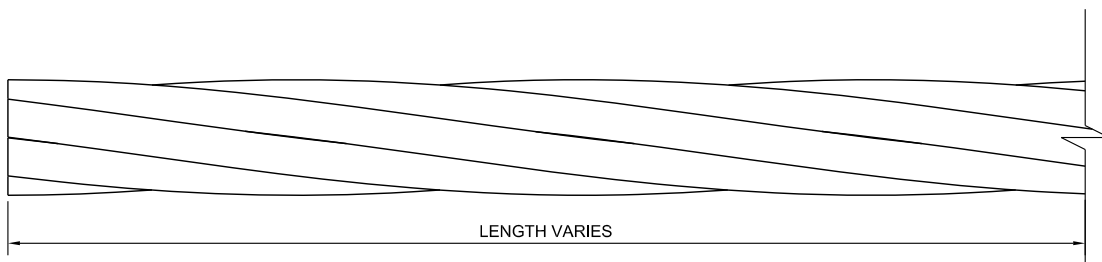

0.6" BARE STRAND

PART NO.: 21001

MATERIAL: 270 KSI LOW RELAXATION STEEL ACCORDING TO ASTM A416

MATERIAL MEETS ALL SPECIFICATIONS.

SCALE: 1'-0" = 1'-0"

THESE DRAWINGS CONTAIN PROPRIETARY INFORMATION RESTRICTED SOLELY FOR USE ON THIS PROJECT. THESE DRAWINGS MAY NOT BE REPRODUCED IN WHOLE OR IN PART, FOR ANY OTHER USE WITHOUT THE EXPRESSED WRITTEN PERMISSION OF SCHWAGER DAVIS INC. (SDI). SDI DOES NOT MAKE ANY JUDGMENT NOR WARRANTY, EXPRESSED OR IMPLIED, AS TO THE ADEQUACY OF THE STRUCTURAL DESIGN BY OTHERS AND HEREBY DISCLAIMS ANY LIABILITY FOR DESIGNS OF OTHERS.

0.6" BARE STRAND

SCHWAGER DAVIS, INC.
POST-TENSION
SYSTEM LIBRARY



SCHWAGER DAVIS, INC.
DESIGN-BUILD CONTRACTOR
198 HILLSDALE AVENUE
SAN JOSE, CA 95136
PHONE: 408.281.9300
FAX: 408.281.9301
www.schwagerdavis.com

DRAWING No: SDI-HD-148

#	REVISIONS	DRAWN	CHECKED	APPROVED	DATE
0	RELEASE	MHA	MSC	MSC	04/02/14
1	UPDATE	CSM	MSC	MSC	05/26/15

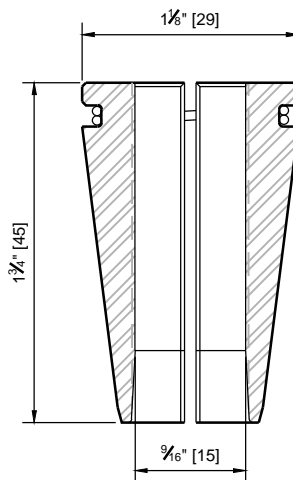
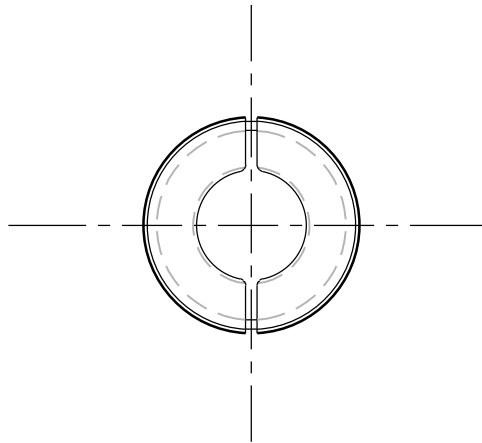

SDI 0.6" WEDGE (2-PART)

PART NO.: 81001

MATERIAL: AISI 11L17 OR 12L14

MATERIAL MEETS ALL SPECIFICATIONS.

PART IDENTIFICATION MARKED ON CONTAINER

SCALE: 1'-0" = 1'-0"

THESE DRAWINGS CONTAIN PROPRIETARY INFORMATION RESTRICTED SOLELY FOR USE ON THIS PROJECT. THESE DRAWINGS MAY NOT BE REPRODUCED IN WHOLE OR IN PART, FOR ANY OTHER USE WITHOUT THE EXPRESSED WRITTEN PERMISSION OF SCHWAGER DAVIS INC. (SDI). SDI DOES NOT MAKE ANY JUDGMENT NOR WARRANTY, EXPRESSED OR IMPLIED, AS TO THE ADEQUACY OF THE STRUCTURAL DESIGN BY OTHERS AND HEREBY DISCLAIMS ANY LIABILITY FOR DESIGNS OF OTHERS.

SDI 0.6" WEDGE
(2-PART)

SCHWAGER DAVIS, INC.
POST-TENSION
SYSTEM LIBRARY



SCHWAGER DAVIS, INC.
DESIGN-BUILD CONTRACTOR
198 HILLSDALE AVENUE
SAN JOSE, CA 95136
PHONE: 408.281.9300
FAX: 408.281.9301
www.schwagerdavis.com

DRAWING No: SDI-HD-021

#	REVISIONS	DRAWN	CHECKED	APPROVED	DATE
0	RELEASE	MCS	GAS	MCS	03/14/11
1	COMMENTS	CMS	MCS	MCS	07/05/13
2	UPDATE	CSM	MSC	MSC	05/26/15
3	UPDATE	JSA	MSC	MSC	06/14/18

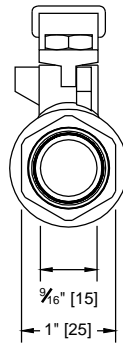
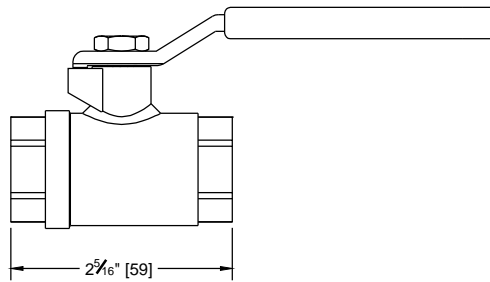

1/2" NPT BALL VALVE (TEMPORARY)

PART NO.: 52010
 MATERIAL: BRASS
 PRESSURE RATING 150 PSI
 MATERIAL MEETS ALL SPECIFICATIONS.
 SCALE: 6" = 1'-0"

THESE DRAWINGS CONTAIN PROPRIETARY INFORMATION RESTRICTED SOLELY FOR USE ON THIS PROJECT. THESE DRAWINGS MAY NOT BE REPRODUCED IN WHOLE OR IN PART, FOR ANY OTHER USE WITHOUT THE EXPRESSED WRITTEN PERMISSION OF SCHWAGER DAVIS INC. (SDI). SDI DOES NOT MAKE ANY JUDGMENT NOR WARRANTY, EXPRESSED OR IMPLIED, AS TO THE ADEQUACY OF THE STRUCTURAL DESIGN BY OTHERS AND HEREBY DISCLAIMS ANY LIABILITY FOR DESIGNS OF OTHERS.

1/2" NPT BALL VALVE
(BRASS)

SCHWAGER DAVIS, INC.
POST-TENSION
SYSTEM LIBRARY



SCHWAGER DAVIS, INC.
 DESIGN-BUILD CONTRACTOR
 198 HILLSDALE AVENUE
 SAN JOSE, CA 95136
 PHONE: 408.281.9300
 FAX: 408.281.9301
 www.schwagerdavis.com

DRAWING No: SDI-HD-337

#	REVISIONS	DRAWN	CHECKED	APPROVED	DATE
0	RELEASE	CSM	MSC	MSC	06/07/16
1	RELEASE	JSA	MSC	MSC	06/28/18

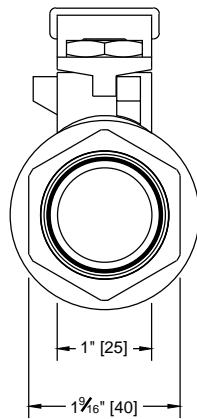
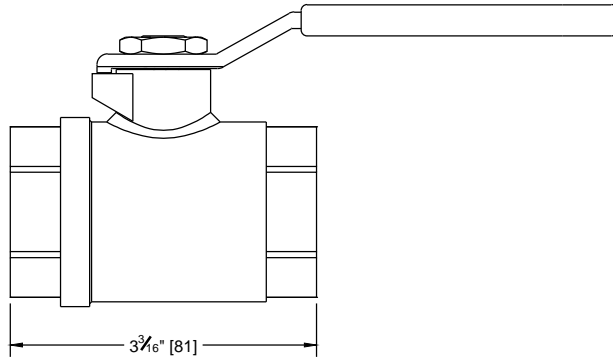

1" NPT BALL VALVE TEMPORARY

PART NO.: 52009
 MATERIAL: BRASS
 PRESSURE RATING: 150 PSI
 MATERIAL MEETS ALL SPECIFICATIONS.
 SCALE: 6" = 1'-0"

THESE DRAWINGS CONTAIN PROPRIETARY INFORMATION RESTRICTED SOLELY FOR USE ON THIS PROJECT. THESE DRAWINGS MAY NOT BE REPRODUCED IN WHOLE OR IN PART, FOR ANY OTHER USE WITHOUT THE EXPRESSED WRITTEN PERMISSION OF SCHWAGER DAVIS INC. (SDI). SDI DOES NOT MAKE ANY JUDGMENT NOR WARRANTY, EXPRESSED OR IMPLIED, AS TO THE ADEQUACY OF THE STRUCTURAL DESIGN BY OTHERS AND HEREBY DISCLAIMS ANY LIABILITY FOR DESIGNS OF OTHERS.

1" NPT BALL VALVE
(BRASS)

SCHWAGER DAVIS, INC.
POST-TENSION
SYSTEM LIBRARY



SCHWAGER DAVIS, INC.
 DESIGN-BUILD CONTRACTOR
 198 HILLSDALE AVENUE
 SAN JOSE, CA 95136
 PHONE: 408.281.9300
 FAX: 408.281.9301
 www.schwagerdavis.com

DRAWING No: SDI-HD-271

#	REVISIONS	DRAWN	CHECKED	APPROVED	DATE
0	RELEASE	CSM	MSC	MSC	06/07/16
1	UPDATE	JSA	MSC	MSC	06/27/18

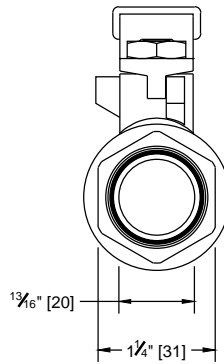
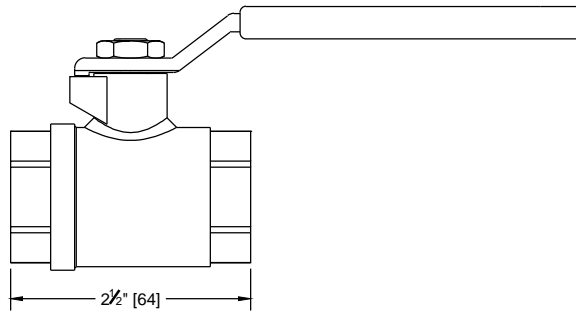

0.75" NPT BALL VALVE (TEMPORARY)

PART NO.: 52010
 MATERIAL: BRASS
 PRESSURE RATING: 150 PSI
 MATERIAL MEETS ALL SPECIFICATIONS.
 SCALE: 6" = 1'-0"

THESE DRAWINGS CONTAIN PROPRIETARY INFORMATION RESTRICTED SOLELY FOR USE ON THIS PROJECT. THESE DRAWINGS MAY NOT BE REPRODUCED IN WHOLE OR IN PART, FOR ANY OTHER USE WITHOUT THE EXPRESSED WRITTEN PERMISSION OF SCHWAGER DAVIS INC. (SDI). SDI DOES NOT MAKE ANY JUDGMENT NOR WARRANTY, EXPRESSED OR IMPLIED, AS TO THE ADEQUACY OF THE STRUCTURAL DESIGN BY OTHERS AND HEREBY DISCLAIMS ANY LIABILITY FOR DESIGNS OF OTHERS.

3/4" NPT BALL VALVE
(BRASS)

SCHWAGER DAVIS, INC.
POST-TENSION
SYSTEM LIBRARY



SCHWAGER DAVIS, INC.
DESIGN-BUILD CONTRACTOR
198 HILLSDALE AVENUE
SAN JOSE, CA 95136
PHONE: 408.281.9300
FAX: 408.281.9301
www.schwagerdavis.com

DRAWING No: SDI-HD-272

#	REVISIONS	DRAWN	CHECKED	APPROVED	DATE
0	RELEASE	CSM	MSC	MSC	06/07/16
1	UPDATE	JSA	MSC	MSC	06/18/18

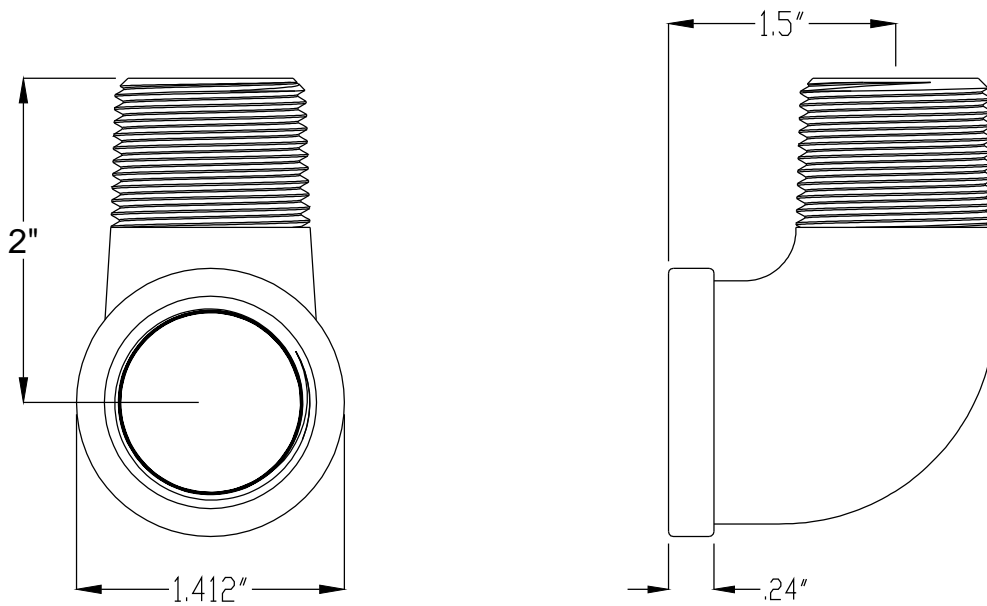

1" NPT FEMALE TO MALE 90° ELBOW

PART NO.: 53013
 MATERIAL: STEEL PER ASTM A53
 PRESSURE RATING: 150 PSI
 MATERIAL MEETS ALL SPECIFICATIONS.
 SCALE: 1'-0" = 1'-0"

THESE DRAWINGS CONTAIN PROPRIETARY INFORMATION RESTRICTED SOLELY FOR USE ON THIS PROJECT. THESE DRAWINGS MAY NOT BE REPRODUCED IN WHOLE OR IN PART, FOR ANY OTHER USE WITHOUT THE EXPRESSED WRITTEN PERMISSION OF SCHWAGER DAVIS INC. (SDI). SDI DOES NOT MAKE ANY JUDGMENT NOR WARRANTY, EXPRESSED OR IMPLIED, AS TO THE ADEQUACY OF THE STRUCTURAL DESIGN BY OTHERS AND HEREBY DISCLAIMS ANY LIABILITY FOR DESIGNS OF OTHERS.

1" NPT FEMALE TO MALE 90°
 ELBOW



SCHWAGER DAVIS, INC.
 POST-TENSION
 SYSTEM LIBRARY

**SCHWAGER
 DAVIS INC.**

SCHWAGER DAVIS, INC.
 DESIGN-BUILD CONTRACTOR
 198 HILLSDALE AVENUE
 SAN JOSE, CA 95136
 PHONE: 408.281.9300
 FAX: 408.281.9301
 www.schwagerdavis.com

DRAWING No: SDI-HD-366

#	REVISIONS	DRAWN	CHECKED	APPROVED	DATE
0	RELEASE	JSA	MSC	MSC	08/08/18

SDI 5.0 33007

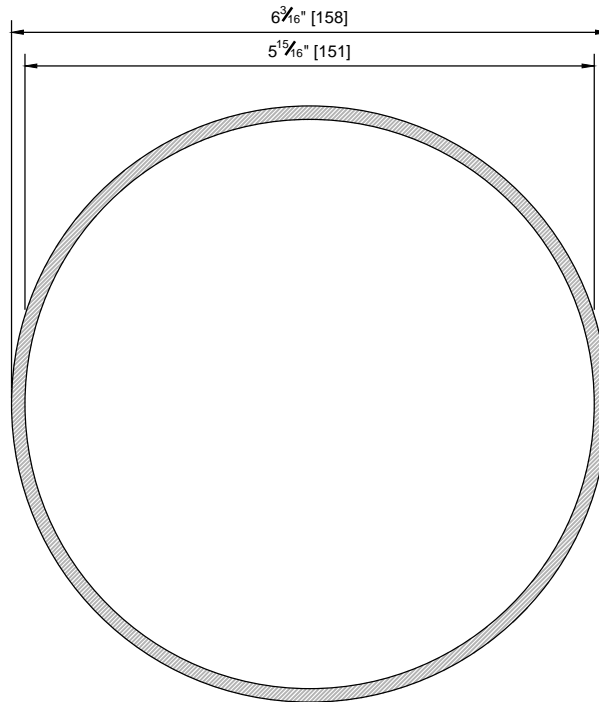
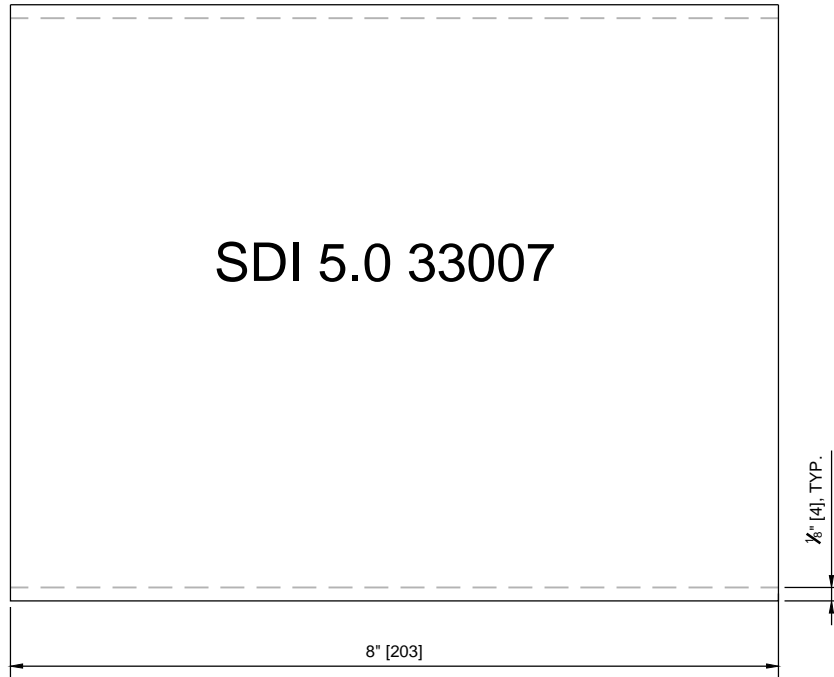

SDI 5" SLIP-ON DUCT COUPLER

PART NO.: 33007

MATERIAL: POLYPROPYLENE

CELL CLASS RANGE: PP0340B44541 TO PP0340B67884

MATERIAL MEETS ALL SPECIFICATIONS.

SCALE: 6" = 1'-0"

THESE DRAWINGS CONTAIN PROPRIETARY INFORMATION RESTRICTED SOLELY FOR USE ON THIS PROJECT. THESE DRAWINGS MAY NOT BE REPRODUCED IN WHOLE OR IN PART, FOR ANY OTHER USE WITHOUT THE EXPRESSED WRITTEN PERMISSION OF SCHWAGER DAVIS INC. (SDI). SDI DOES NOT MAKE ANY JUDGMENT NOR WARRANTY, EXPRESSED OR IMPLIED, AS TO THE ADEQUACY OF THE STRUCTURAL DESIGN BY OTHERS AND HEREBY DISCLAIMS ANY LIABILITY FOR DESIGNS OF OTHERS.

SDI 5" SLIP-ON
DUCT COUPLER

SCHWAGER DAVIS, INC.
POST-TENSION
SYSTEM LIBRARY



SCHWAGER DAVIS, INC.
DESIGN-BUILD CONTRACTOR
198 HILLSDALE AVENUE
SAN JOSE, CA 95136
PHONE: 408.281.9300
FAX: 408.281.9301
www.schwagerdavis.com

DRAWING No: SDI-HD-216

#	REVISIONS	DRAWN	CHECKED	APPROVED	DATE
0	RELEASE	MCS	JWM	MCS	09-18-2014
1	REVISION	MCS	JWM	MCS	09-20-2014
2	UPDATE	CSM	MSC	MSC	05-26-2015
3	UPDATE	JSA	MSC	MSC	06-29-2018

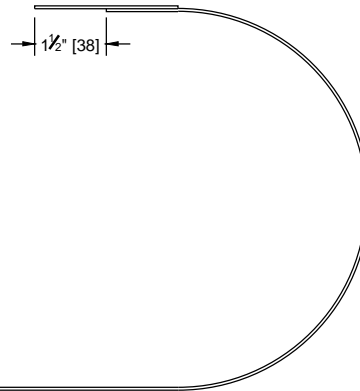
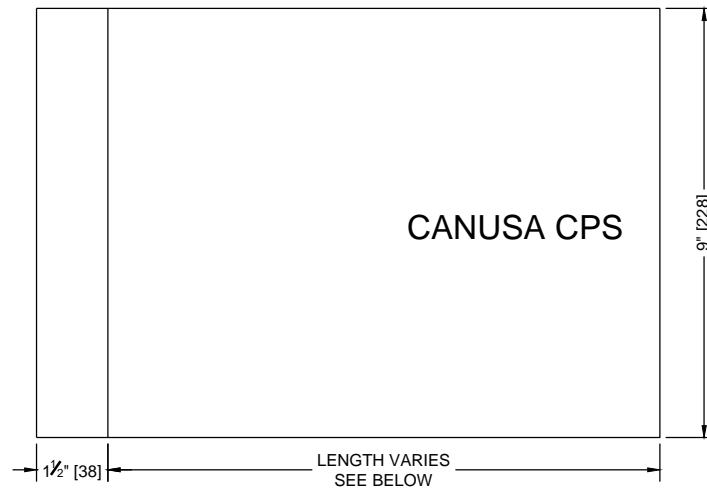

KLNN HEAT SHRINK

PART NO.: 37008

MATERIAL: POLYOLEFIN

MATERIAL MEETS ALL SPECIFICATIONS.

- 1" x 3" & 2" - KLNN-63 WS BK/L 9" HEAT SHRINK SLEEVE
- 3" - KLNN-90 WS BK/L 9" HEAT SHRINK SLEEVE
- 4" - KLNN-115 WS BK/L 9" HEAT SHRINK SLEEVE
- 4.5" & 5" - KLNN-125 WS BK/L 9" HEAT SHRINK SLEEVE

NOTE: FOLLOW MANUFACTURER'S INSTALLATION INSTRUCTIONS

THESE DRAWINGS CONTAIN PROPRIETARY INFORMATION RESTRICTED SOLELY FOR USE ON THIS PROJECT. THESE DRAWINGS MAY NOT BE REPRODUCED IN WHOLE OR IN PART, FOR ANY OTHER USE WITHOUT THE EXPRESSED WRITTEN PERMISSION OF SCHWAGER DAVIS INC. (SDI). SDI DOES NOT MAKE ANY JUDGMENT NOR WARRANTY, EXPRESSED OR IMPLIED, AS TO THE ADEQUACY OF THE STRUCTURAL DESIGN BY OTHERS AND HEREBY DISCLAIMS ANY LIABILITY FOR DESIGNS OF OTHERS.

KLNN HEAT SHRINK

SCHWAGER DAVIS, INC.
POST-TENSION
SYSTEM LIBRARY



SCHWAGER DAVIS, INC.
DESIGN-BUILD CONTRACTOR
198 HILLSDALE AVENUE
SAN JOSE, CA 95136
PHONE: 408.281.9300
FAX: 408.281.9301
www.schwagerdavis.com

DRAWING No: SDI-HD-367

#	REVISIONS	DRAWN	CHECKED	APPROVED	DATE
0	RELEASE	JSA	MSC	MSC	08/09/18

KLON & KLNN

One-piece protective sleeve with pre-attached closure

Product Description



Canusa WrapidSleeves[®] are shipped pre-cut with a pre-attached closure. The adhesive is protected from contamination by an inner liner.

Equipment List

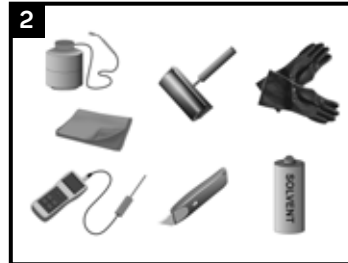

Propane tank, hose, torch & regulator; Appropriate tools for surface abrasion; Knife, roller, rags & approved solvent cleanser; Digital thermometer with suitable probe; Standard safety equipment; gloves, goggles, hard hat, etc.

Flame Intensity & Torch Size

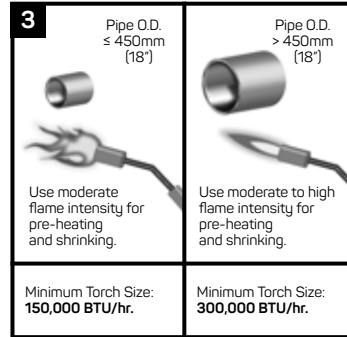

Surface Preparation

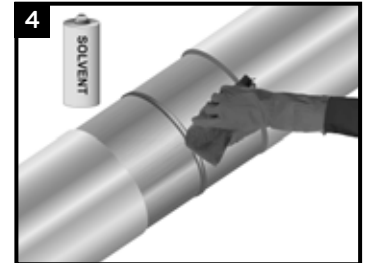

Ensure that the PE coating edges are beveled to 30°. Clean exposed steel and adjacent pipe coating with a solvent cleanser to remove the presence of oil, grease, and other contaminants.



Ensure that the pipe is dry before cleaning. Using a power wire brush, abrade the pipe to a minimum of St3/SP3 (abrasive blast to Sa2.5/SP10 recommended). Lightly abrade the pipe coating adjacent to the cutback area to a distance of 50mm (2") beyond each end of the sleeve width.

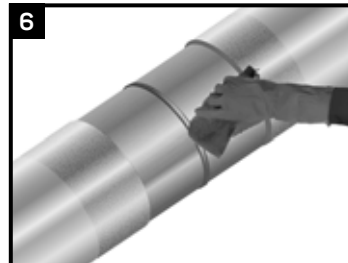

Wipe clean or air blast the steel and pipe coating to remove foreign contaminants.

Pre-Heat

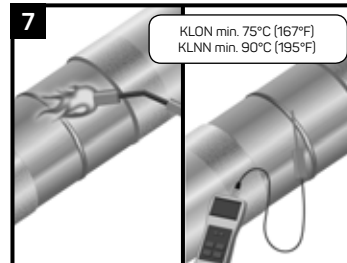

Pre-heat the joint area to the minimum required temperature. Using a temperature measuring device, ensure that the correct temperature is reached on the steel and at least 50mm (2") on each side of the sleeve.

Sleeve Installation



Partially remove the release liner and gently heat the underlap approximately 150 mm (6") from the edge.

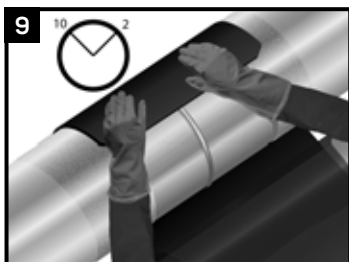

Centre the sleeve over the joint so that the sleeve overlaps between the 10 and 2 o'clock positions. Press the underlap firmly into place.

Sleeve Installation

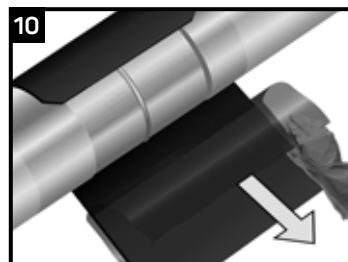

Remove the remaining release liner.

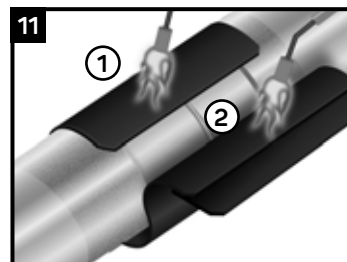

Wrap the sleeve loosely around the pipe, ensuring the appropriate overlap. Gently heat the backing of the underlap and the adhesive side of the overlap.

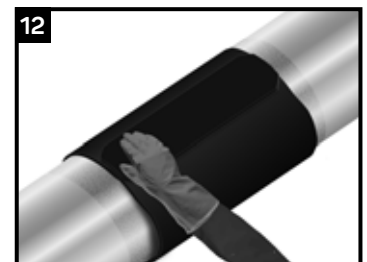

Press the closure firmly into place.

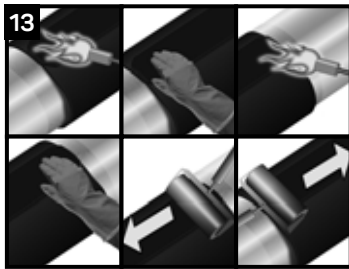

Gently heat the closure and pat it down with a gloved hand. Repeating this procedure, move from one side to the other. Smooth any wrinkles by gently working them outward from the centre of the closure with a roller.

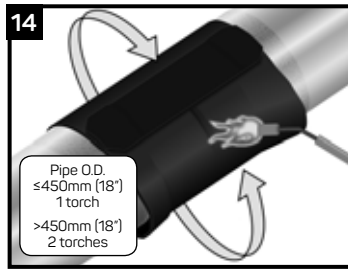

Using the appropriate torch, begin at the centre of the sleeve and heat circumferentially around the pipe. Use broad strokes. If utilizing two torches, operators should work on opposite sides of the pipe.

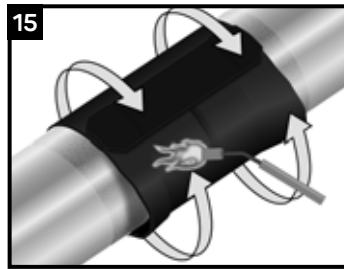

Continue heating from the centre toward one end of the sleeve until recovery is complete. In a similar manner, heat and shrink the remaining side.

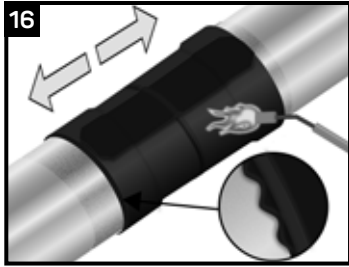

Shrinking has been completed when the adhesive begins to ooze at the sleeve edges all around the circumference. Finish shrinking the sleeve with long horizontal strokes over the entire surface to ensure a uniform bond.

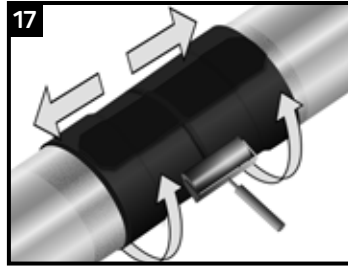

While the sleeve is still hot and soft, use a hand roller to gently roll the sleeve surface and push any trapped air up and out of the sleeve, as shown above. If necessary, reheat to roll out air.

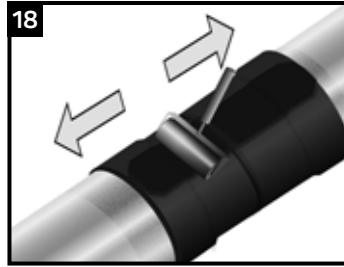

Continue the procedure by also firmly rolling the closure with long horizontal strokes from the weld outwards.

Inspection



Visually inspect the installed patch for the following:

- Sleeve is in full contact with the steel joint.
- Adhesive flows beyond both sleeve edges.
- No cracks or holes in sleeve backing.

Backfilling Guidelines

After shrinking is complete, allow the sleeve to cool for 2 hours prior to lowering and backfilling. To prevent damage to the sleeve, use selected backfill material, (no sharp stones or large particles) otherwise an extruded polyethylene mesh or other suitable shield should be used.

Storage & Safety Guidelines

To ensure maximum performance, store Canusa products in a dry, ventilated area. Keep products sealed in original cartons and avoid exposure to direct sunlight, rain, snow, dust or other adverse environmental elements. Avoid prolonged storage at temperatures above 35°C (95°F) or below -20°C (-4°F). Product installation should be done in accordance with local health and safety regulations.

These installation instructions are intended as a guide for standard products. Consult your Canusa representative for specific projects or unique applications.

Canusa-CPS A division of Shawcor Ltd.

Head Office

25 Bethridge Road
Toronto, ON, Canada M9W 1M7
Tel: +1 416 743 7111
Fax: +1 416 743 5927

Canada

Dome Tower St. 2200,
333-7th Avenue SW
Calgary, AB, Canada T2P 2Z1
Tel: +1 403 218 8207
Fax: +1 403 264 3649

Americas

5875 N. Sam Houston Pkwy W.,
Suite 200
Houston, TX, USA 77086
Tel: +1 281 886 2350
Fax: +1 281 886 2353

Middle East

ADPC - Mussafah Port,
P.O. Box 2621
Abu Dhabi, UAE
Tel: +971 2 496 3500
Fax: +971 2 496 3501

Europe, Africa & Russia

Dellaertweg 9-E, Gebouw
"Le Carrefour"
2316 WZ Leiden,
The Netherlands (NL)
Tel: +31 71 80 802 70
Fax: +31 71 80 802 71

Asia-Pacific

101 Thomson Road,
#11-03 United Square
307591 Singapore
Tel: +65 6749 8918
Fax: +65 6749 8919

Quality Management system registered to ISO 9001

Canusa warrants that the product conforms to its chemical and physical description and is appropriate for the use stated on the installation guide when used in compliance with Canusa's written instructions. Since many installation factors are beyond our control, the user shall determine the suitability of the products for the intended use and assume all risks and liabilities in connection therewith. Canusa's liability is stated in the standard terms and conditions of sale. Canusa makes no other warranty either expressed or implied. All information contained in this installation guide is to be used as a guide and is subject to change without notice. This installation guide supersedes all previous installation guides on this product. E&OE

Part No. 99060-266

IG_KLON & KLNN_rev013

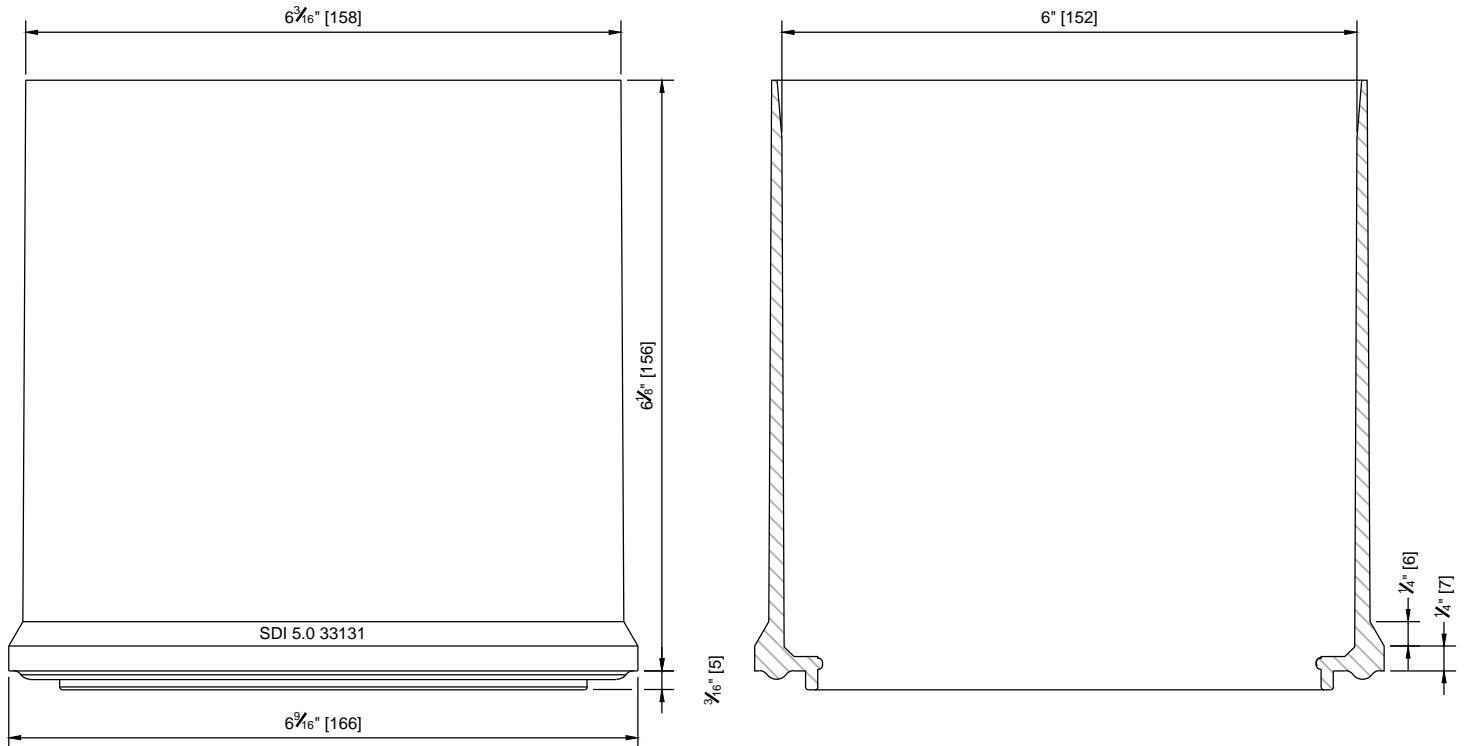

SDI 5" SEGMENT COUPLER SLIDE HOUSING

PART NO.: 33131
 MATERIAL: POLYPROPYLENE
 CELL CLASS RANGE: PP0340B44541 TO PP03040B67884
 MATERIAL MEETS ALL SPECIFICATIONS.
 SCALE: 6" = 1'-0"

THESE DRAWINGS CONTAIN PROPRIETARY INFORMATION RESTRICTED SOLELY FOR USE ON THIS PROJECT. THESE DRAWINGS MAY NOT BE REPRODUCED IN WHOLE OR IN PART, FOR ANY OTHER USE WITHOUT THE EXPRESSED WRITTEN PERMISSION OF SCHWAGER DAVIS INC. (SDI). SDI DOES NOT MAKE ANY JUDGMENT NOR WARRANTY, EXPRESSED OR IMPLIED, AS TO THE ADEQUACY OF THE STRUCTURAL DESIGN BY OTHERS AND HEREBY DISCLAIMS ANY LIABILITY FOR DESIGNS OF OTHERS.

<p>SDI 5" SEGMENT COUPLER SLIDE HOUSING</p>	 <p>SCHWAGER DAVIS INC.</p>	<p>SCHWAGER DAVIS, INC. DESIGN-BUILD CONTRACTOR 198 HILLSDALE AVENUE SAN JOSE, CA 95136 PHONE: 408.281.9300 FAX: 408.281.9301 www.schwagerdavis.com</p>	<p>DRAWING No: SDI-HD-226</p> <table border="1" style="width: 100%; border-collapse: collapse;"> <thead> <tr> <th>#</th> <th>REVISIONS</th> <th>DRAWN</th> <th>CHECKED</th> <th>APPROVED</th> <th>DATE</th> </tr> </thead> <tbody> <tr> <td>0</td> <td>RELEASE</td> <td>MHA</td> <td>JMY</td> <td>MSC</td> <td>09/19/14</td> </tr> <tr> <td>1</td> <td>UPDATE</td> <td>CSM</td> <td>MSC</td> <td>MSC</td> <td>05/26/15</td> </tr> <tr> <td>2</td> <td>UPDATE</td> <td>JSA</td> <td>MSC</td> <td>MSC</td> <td>06/29/18</td> </tr> <tr> <td> </td> <td> </td> <td> </td> <td> </td> <td> </td> <td> </td> </tr> </tbody> </table>	#	REVISIONS	DRAWN	CHECKED	APPROVED	DATE	0	RELEASE	MHA	JMY	MSC	09/19/14	1	UPDATE	CSM	MSC	MSC	05/26/15	2	UPDATE	JSA	MSC	MSC	06/29/18						
#	REVISIONS	DRAWN	CHECKED	APPROVED	DATE																												
0	RELEASE	MHA	JMY	MSC	09/19/14																												
1	UPDATE	CSM	MSC	MSC	05/26/15																												
2	UPDATE	JSA	MSC	MSC	06/29/18																												
<p>SCHWAGER DAVIS, INC. POST-TENSION SYSTEM LIBRARY</p>																																	

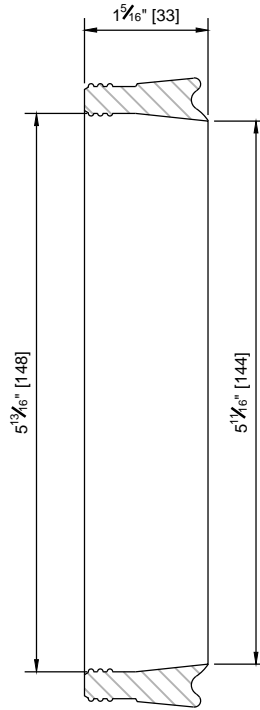
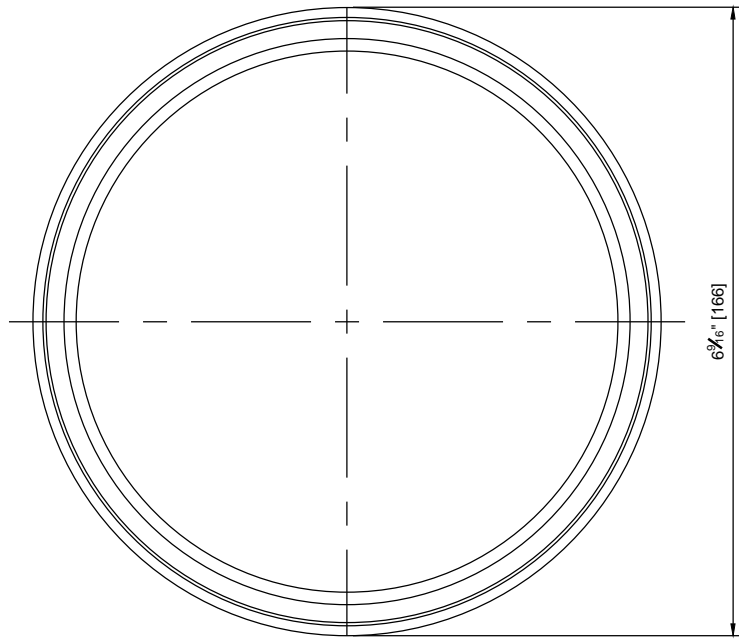

SDI 5" SEGMENT COUPLER SEAL

PART NO.: 33133

MATERIAL: BUNA-N PER ASTM D2240, & D412

MATERIAL MEETS ALL SPECIFICATIONS.

SCALE: 6" = 1'-0"

THESE DRAWINGS CONTAIN PROPRIETARY INFORMATION RESTRICTED SOLELY FOR USE ON THIS PROJECT. THESE DRAWINGS MAY NOT BE REPRODUCED IN WHOLE OR IN PART, FOR ANY OTHER USE WITHOUT THE EXPRESSED WRITTEN PERMISSION OF SCHWAGER DAVIS INC. (SDI). SDI DOES NOT MAKE ANY JUDGMENT NOR WARRANTY, EXPRESSED OR IMPLIED, AS TO THE ADEQUACY OF THE STRUCTURAL DESIGN BY OTHERS AND HEREBY DISCLAIMS ANY LIABILITY FOR DESIGNS OF OTHERS.

SDI 5" SEGMENT
COUPLER SEAL

SCHWAGER DAVIS, INC.
POST-TENSION
SYSTEM LIBRARY



SCHWAGER DAVIS, INC.
DESIGN-BUILD CONTRACTOR
198 HILLSDALE AVENUE
SAN JOSE, CA 95136
PHONE: 408.281.9300
FAX: 408.281.9301
www.schwagerdavis.com

DRAWING No: SDI-HD-229

#	REVISIONS	DRAWN	CHECKED	APPROVED	DATE
0	RELEASE	MHA	JMY	MSC	09/19/14
1	UPDATE	CSM	MSC	MSC	05/26/15
2	MATERIAL UPDATE	CSM	JMY	MSC	06/08/16
3	MATERIAL UPDATE	JSA	JMY	MSC	06/29/18

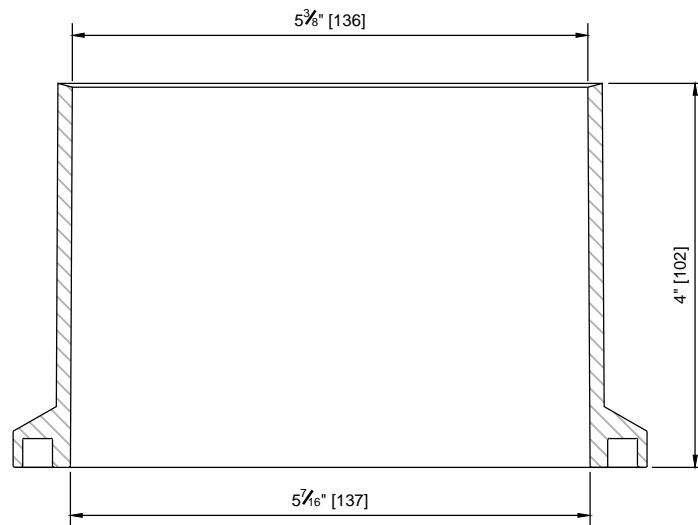
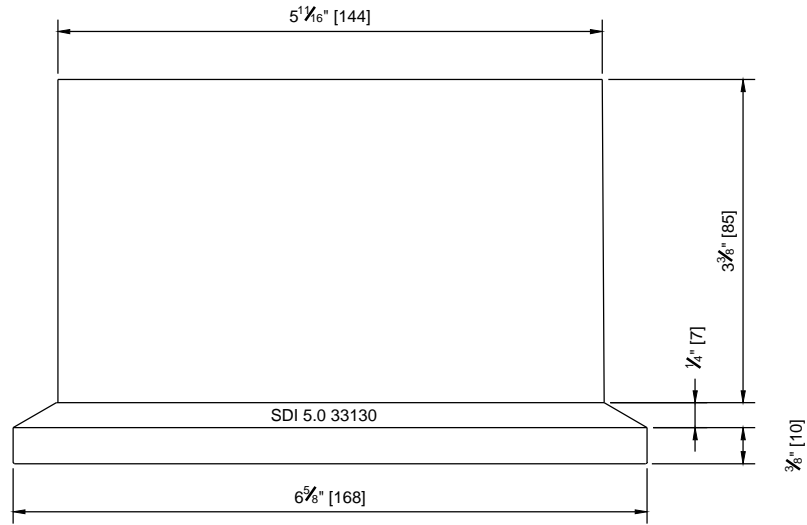

SDI 5" SEGMENT COUPLER WELDED HOUSING

PART NO.: 33130
 MATERIAL: POLYPROPYLENE
 CELL CLASS RANGE: PP0340B44541 TO PP0340B67884
 MATERIAL MEETS ALL SPECIFICATIONS.
 SCALE: 6" = 1'-0"

THESE DRAWINGS CONTAIN PROPRIETARY INFORMATION RESTRICTED SOLELY FOR USE ON THIS PROJECT. THESE DRAWINGS MAY NOT BE REPRODUCED IN WHOLE OR IN PART, FOR ANY OTHER USE WITHOUT THE EXPRESSED WRITTEN PERMISSION OF SCHWAGER DAVIS INC. (SDI). SDI DOES NOT MAKE ANY JUDGMENT NOR WARRANTY, EXPRESSED OR IMPLIED, AS TO THE ADEQUACY OF THE STRUCTURAL DESIGN BY OTHERS AND HEREBY DISCLAIMS ANY LIABILITY FOR DESIGNS OF OTHERS.

SDI 5" SEGMENT
 COUPLER WELDED
 HOUSING

SCHWAGER DAVIS, INC.
 POST-TENSION
 SYSTEM LIBRARY



SCHWAGER DAVIS, INC.
 DESIGN-BUILD CONTRACTOR
 198 HILLSDALE AVENUE
 SAN JOSE, CA 95136
 PHONE: 408.281.9300
 FAX: 408.281.9301
 www.schwagerdavis.com

DRAWING No: SDI-HD-225

#	REVISIONS	DRAWN	CHECKED	APPROVED	DATE
0	RELEASE	MHA	JMY	MSC	09/19/14
1	UPDATE	CSM	MSC	MSC	05/26/15
2	UPDATE	JSA	MSC	MSC	06/29/18

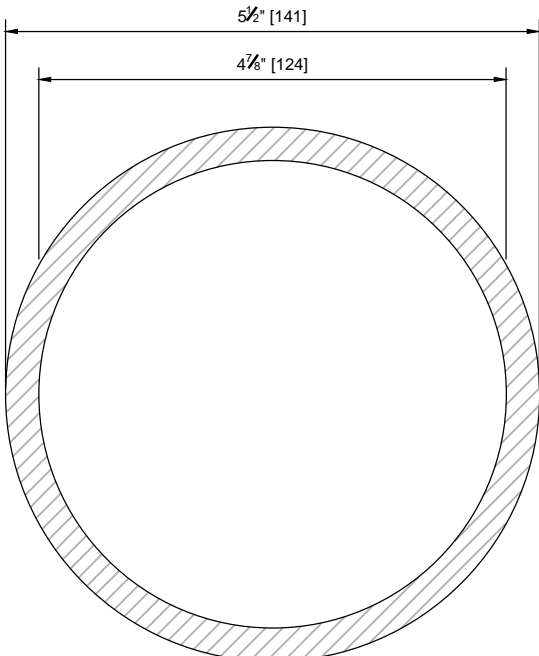
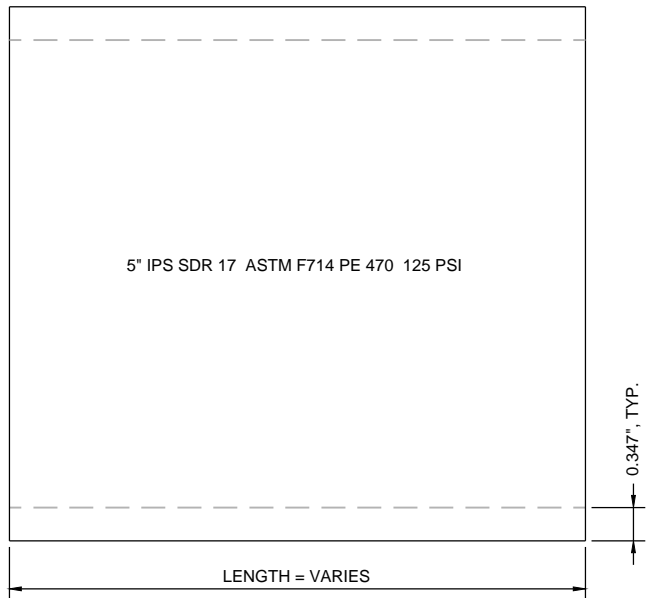

5" HDPE EXTERIOR PIPE

PART NO.: 35005
 MATERIAL: HDPE WITH A DIMENSION RATIO (DR) OF 17
 BEND RADIUS: 30 FT
 MATERIAL MEETS ALL SPECIFICATIONS.
 SCALE: 6" = 1'-0"

THESE DRAWINGS CONTAIN PROPRIETARY INFORMATION RESTRICTED SOLELY FOR USE ON THIS PROJECT. THESE DRAWINGS MAY NOT BE REPRODUCED IN WHOLE OR IN PART, FOR ANY OTHER USE WITHOUT THE EXPRESSED WRITTEN PERMISSION OF SCHWAGER DAVIS INC. (SDI). SDI DOES NOT MAKE ANY JUDGMENT NOR WARRANTY, EXPRESSED OR IMPLIED, AS TO THE ADEQUACY OF THE STRUCTURAL DESIGN BY OTHERS AND HEREBY DISCLAIMS ANY LIABILITY FOR DESIGNS OF OTHERS.

5" HDPE EXTERIOR PIPE

SCHWAGER DAVIS, INC.
 POST-TENSION SYSTEM LIBRARY



SCHWAGER DAVIS, INC.
 DESIGN-BUILD CONTRACTOR
 198 HILLSDALE AVENUE
 SAN JOSE, CA 95136
 PHONE: 408.281.9300
 FAX: 408.281.9301
 www.schwagerdavis.com

DRAWING No: SDI-HD-182					
#	REVISIONS	DRAWN	CHECKED	APPROVED	DATE
0	RELEASE	MHA	MSC	MSC	04/03/14
1	UPDATE	CSM	MSC	MSC	05/26/15
2	UPDATE	JSA	MSC	MSC	08/16/18

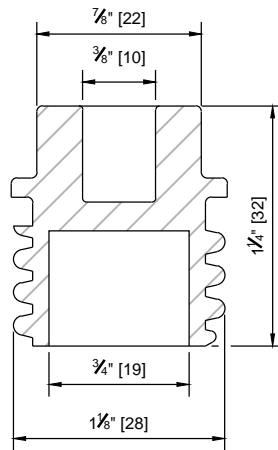
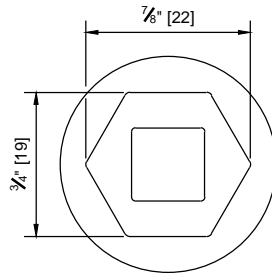

SDI GROUT PORT PLUG

PART NO.: 55004
 MATERIAL: POLYPROPYLENE
 CELL CLASS RANGE: PP0340B44541 TO PP0340B67884
 PRESSURE RATING: 150 PSI
 MATERIAL MEETS ALL SPECIFICATIONS.
 SCALE: 1'-0" = 1'-0"

THESE DRAWINGS CONTAIN PROPRIETARY INFORMATION RESTRICTED SOLELY FOR USE ON THIS PROJECT. THESE DRAWINGS MAY NOT BE REPRODUCED IN WHOLE OR IN PART, FOR ANY OTHER USE WITHOUT THE EXPRESSED WRITTEN PERMISSION OF SCHWAGER DAVIS INC. (SDI). SDI DOES NOT MAKE ANY JUDGMENT NOR WARRANTY, EXPRESSED OR IMPLIED, AS TO THE ADEQUACY OF THE STRUCTURAL DESIGN BY OTHERS AND HEREBY DISCLAIMS ANY LIABILITY FOR DESIGNS OF OTHERS.

SDI GROUT PORT PLUG

SCHWAGER DAVIS, INC.
 POST-TENSION
 SYSTEM LIBRARY



SCHWAGER DAVIS, INC.
 DESIGN-BUILD CONTRACTOR
 198 HILLSDALE AVENUE
 SAN JOSE, CA 95136
 PHONE: 408.281.9300
 FAX: 408.281.9301
 www.schwagerdavis.com

DRAWING No: SDI-HD-257

#	REVISIONS	DRAWN	CHECKED	APPROVED	DATE
0	RELEASE	CSM	MSC	MSC	05/26/15
1	UPDATE	JSA	MSC	MSC	06/19/18

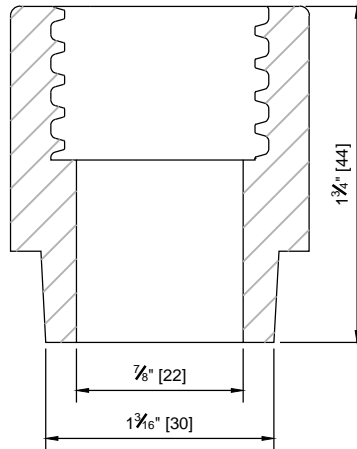
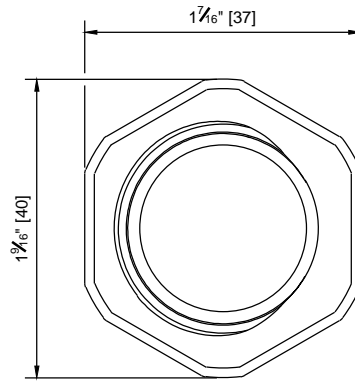

HDPE WELDABLE GROUT PORT WITH 3/4" NOM. (23mm) GROUT THREAD

PART NO.: 57004
 MATERIAL: HDPE
 PRESSURE RATING: 150 PSI
 MATERIAL MEETS ALL SPECIFICATIONS.
 SCALE: 1'-0" = 1'-0"

NOTE: FOLLOW MANUFACTURE'S INSTALLATION INSTRUCTIONS.

THESE DRAWINGS CONTAIN PROPRIETARY INFORMATION RESTRICTED SOLELY FOR USE ON THIS PROJECT. THESE DRAWINGS MAY NOT BE REPRODUCED IN WHOLE OR IN PART, FOR ANY OTHER USE WITHOUT THE EXPRESSED WRITTEN PERMISSION OF SCHWAGER DAVIS INC. (SDI). SDI DOES NOT MAKE ANY JUDGMENT NOR WARRANTY, EXPRESSED OR IMPLIED, AS TO THE ADEQUACY OF THE STRUCTURAL DESIGN BY OTHERS AND HEREBY DISCLAIMS ANY LIABILITY FOR DESIGNS OF OTHERS.

HDPE WELDABLE GROUT PORT WITH
 3/4" NOM. (23mm) GROUT THREAD



SCHWAGER DAVIS, INC.
 POST-TENSION
 SYSTEM LIBRARY

SCHWAGER DAVIS, INC.
 DESIGN-BUILD CONTRACTOR
 198 HILLSDALE AVENUE
 SAN JOSE, CA 95136
 PHONE: 408.281.9300
 FAX: 408.281.9301
 www.schwagerdavis.com

DRAWING No: SDI-HD-172

#	REVISIONS	DRAWN	CHECKED	APPROVED	DATE
0	RELEASE	MHA	MSC	MSC	03/25/14
1	UPDATE	CSM	MSC	MSC	05/26/15
2	UPDATE	JSA	MSC	MSC	07/02/18

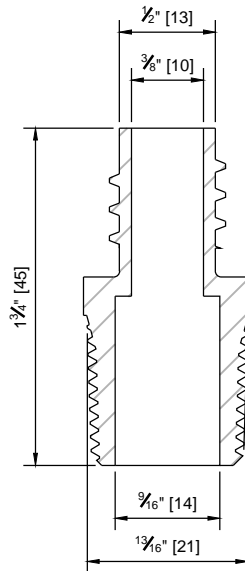
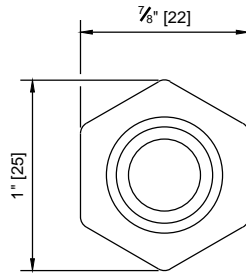

1/2" NOM. (13mm) NPT COUPLER

PART NO.: 53011

MATERIAL: POLYPROPYLENE

CELL CLASS RANGE: PP0340B44541 TO PP0340B67884

PRESSURE RATING: 150 PSI

MATERIAL MEETS ALL SPECIFICATIONS.

SCALE: 1'-0" = 1'-0"

THESE DRAWINGS CONTAIN PROPRIETARY INFORMATION RESTRICTED SOLELY FOR USE ON THIS PROJECT. THESE DRAWINGS MAY NOT BE REPRODUCED IN WHOLE OR IN PART, FOR ANY OTHER USE WITHOUT THE EXPRESSED WRITTEN PERMISSION OF SCHWAGER DAVIS INC. (SDI). SDI DOES NOT MAKE ANY JUDGMENT NOR WARRANTY, EXPRESSED OR IMPLIED, AS TO THE ADEQUACY OF THE STRUCTURAL DESIGN BY OTHERS AND HEREBY DISCLAIMS ANY LIABILITY FOR DESIGNS OF OTHERS.

1/2" NOM. (13mm) NPT
COUPLER

SCHWAGER DAVIS, INC.
POST-TENSION
SYSTEM LIBRARY



SCHWAGER DAVIS, INC.
DESIGN-BUILD CONTRACTOR
198 HILLSDALE AVENUE
SAN JOSE, CA 95136
PHONE: 408.281.9300
FAX: 408.281.9301
www.schwagerdavis.com

DRAWING No: SDI-HD-222

#	REVISIONS	DRAWN	CHECKED	APPROVED	DATE
0	RELEASE	MHA	MSC	MSC	10/10/14
1	UPDATE	CSM	MSC	MSC	05/26/15
2	UPDATE	JSA	MSC	MSC	06/19/18

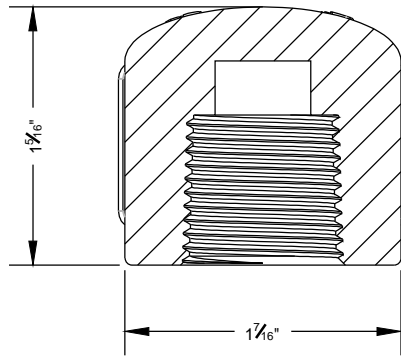
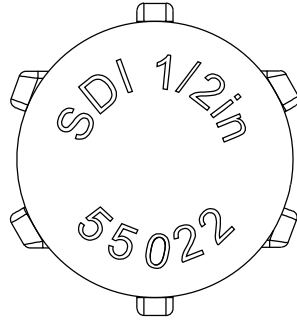

1/2" POLYPROPYLENE NPT CAP

PART NO.: 55022
 MATERIAL: POLYPROPYLENE
 PRESSURE RATING: 150 PSI
 MATERIAL MEETS ALL SPECIFICATIONS.
 SCALE: 1'-0" = 1'-0"

THESE DRAWINGS CONTAIN PROPRIETARY INFORMATION RESTRICTED SOLELY FOR USE ON THIS PROJECT. THESE DRAWINGS MAY NOT BE REPRODUCED IN WHOLE OR IN PART, FOR ANY OTHER USE WITHOUT THE EXPRESSED WRITTEN PERMISSION OF SCHWAGER DAVIS INC. (SDI). SDI DOES NOT MAKE ANY JUDGMENT NOR WARRANTY, EXPRESSED OR IMPLIED, AS TO THE ADEQUACY OF THE STRUCTURAL DESIGN BY OTHERS AND HEREBY DISCLAIMS ANY LIABILITY FOR DESIGNS OF OTHERS.

1/2" POLYPROPYLENE
 NPT CAP

SCHWAGER DAVIS, INC.
 POST-TENSION
 SYSTEM LIBRARY



SCHWAGER DAVIS, INC.
 DESIGN-BUILD CONTRACTOR
 198 HILLSDALE AVENUE
 SAN JOSE, CA 95136
 PHONE: 408.281.9300
 FAX: 408.281.9301
 www.schwagerdavis.com

DRAWING No: SDI-HD-360

#	REVISIONS	DRAWN	CHECKED	APPROVED	DATE
0	RELEASE	MHA	MSC	MSC	08/21/18

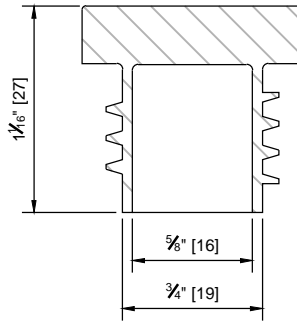
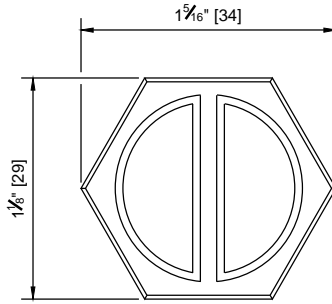

3/4" NOM. (23mm) GROUT TUBE PLUG

PART NO.: 55001
 MATERIAL: POLYPROPYLENE
 CELL CLASS RANGE: PP0340B44541 TO PP0340B67884
 PRESSURE RATING: 150 PSI
 MATERIAL MEETS ALL SPECIFICATIONS.
 SCALE: 1'-0" = 1'-0"

THESE DRAWINGS CONTAIN PROPRIETARY INFORMATION RESTRICTED SOLELY FOR USE ON THIS PROJECT. THESE DRAWINGS MAY NOT BE REPRODUCED IN WHOLE OR IN PART, FOR ANY OTHER USE WITHOUT THE EXPRESSED WRITTEN PERMISSION OF SCHWAGER DAVIS INC. (SDI). SDI DOES NOT MAKE ANY JUDGMENT NOR WARRANTY, EXPRESSED OR IMPLIED, AS TO THE ADEQUACY OF THE STRUCTURAL DESIGN BY OTHERS AND HEREBY DISCLAIMS ANY LIABILITY FOR DESIGNS OF OTHERS.

**3/4" NOM.(23mm) GROUT
TUBE PLUG**

**SCHWAGER DAVIS, INC.
POST-TENSION
SYSTEM LIBRARY**



SCHWAGER DAVIS, INC.
 DESIGN-BUILD CONTRACTOR
 198 HILLSDALE AVENUE
 SAN JOSE, CA 95136
 PHONE: 408.281.9300
 FAX: 408.281.9301
 www.schwagerdavis.com

DRAWING No: SDI-HD-156

#	REVISIONS	DRAWN	CHECKED	APPROVED	DATE
0	RELEASE	MHA	MSC	MSC	04/02/14
1	UPDATE	CSM	MSC	MSC	05/26/15
2	UPDATE	JSA	MSC	MSC	06/19/18

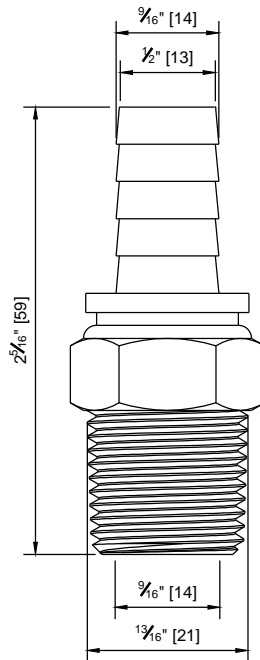
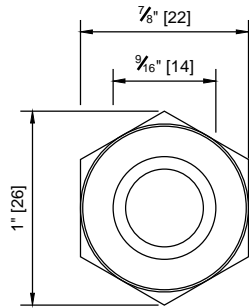

1/2" MALE BARB HOSE ADAPTOR

PART NO.: 53014
 MATERIAL: BRASS
 PRESSURE RATING: 150 PSI
 MATERIAL MEETS ALL SPECIFICATIONS.
 SCALE: 1'-0" = 1'-0"

THESE DRAWINGS CONTAIN PROPRIETARY INFORMATION RESTRICTED SOLELY FOR USE ON THIS PROJECT. THESE DRAWINGS MAY NOT BE REPRODUCED IN WHOLE OR IN PART, FOR ANY OTHER USE WITHOUT THE EXPRESSED WRITTEN PERMISSION OF SCHWAGER DAVIS INC. (SDI). SDI DOES NOT MAKE ANY JUDGMENT NOR WARRANTY, EXPRESSED OR IMPLIED, AS TO THE ADEQUACY OF THE STRUCTURAL DESIGN BY OTHERS AND HEREBY DISCLAIMS ANY LIABILITY FOR DESIGNS OF OTHERS.

1/2" BARB HOSE
 ADAPTOR

SCHWAGER DAVIS, INC.
 POST-TENSION
 SYSTEM LIBRARY



SCHWAGER DAVIS, INC.
 DESIGN-BUILD CONTRACTOR
 198 HILLSDALE AVENUE
 SAN JOSE, CA 95136
 PHONE: 408.281.9300
 FAX: 408.281.9301
 www.schwagerdavis.com

DRAWING No: SDI-HD-365

#	REVISIONS	DRAWN	CHECKED	APPROVED	DATE
0	RELEASE	JSA	MSC	MSC	08/08/18

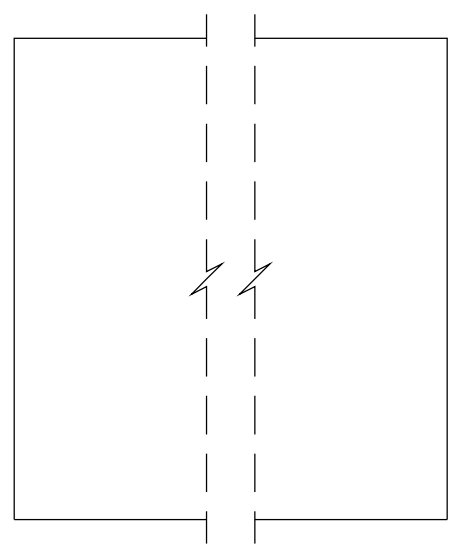
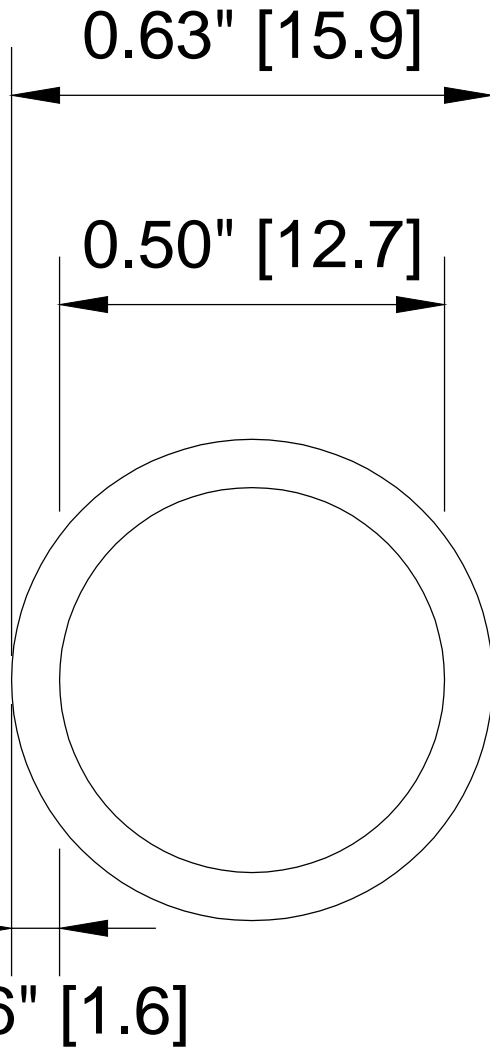

1/2" CLEAR HIGH TEMP. VACUUM TUBE

PART NO.: 59001
 MATERIAL: FLUORINATED ETHYLENE PROPYLENE
 PRESSURE RATING: 180 PSI @ 72° F
 TEMPERATURE RANGE: -100° TO 400° F
 BENDING RADIUS: 3"
 MATERIAL MEETS ALL SPECIFICATIONS.
 SCALE: 1'-0" = 1'-0"

THESE DRAWINGS CONTAIN PROPRIETARY INFORMATION RESTRICTED SOLELY FOR USE ON THIS PROJECT. THESE DRAWINGS MAY NOT BE REPRODUCED IN WHOLE OR IN PART, FOR ANY OTHER USE WITHOUT THE EXPRESSED WRITTEN PERMISSION OF SCHWAGER DAVIS INC. (SDI). SDI DOES NOT MAKE ANY JUDGMENT NOR WARRANTY, EXPRESSED OR IMPLIED, AS TO THE ADEQUACY OF THE STRUCTURAL DESIGN BY OTHERS AND HEREBY DISCLAIMS ANY LIABILITY FOR DESIGNS OF OTHERS.

1/2" CLEAR HIGH TEMP.
VACUUM TUBE

SCHWAGER DAVIS, INC.
POST-TENSION
SYSTEM LIBRARY



SCHWAGER DAVIS, INC.
DESIGN-BUILD CONTRACTOR
198 HILLSDALE AVENUE
SAN JOSE, CA 95136
PHONE: 408.281.9300
FAX: 408.281.9301
www.schwagerdavis.com

DRAWING No: SDI-HD-364					
#	REVISIONS	DRAWN	CHECKED	APPROVED	DATE
0	RELEASE	JSA	MSC	MSC	08/08/18

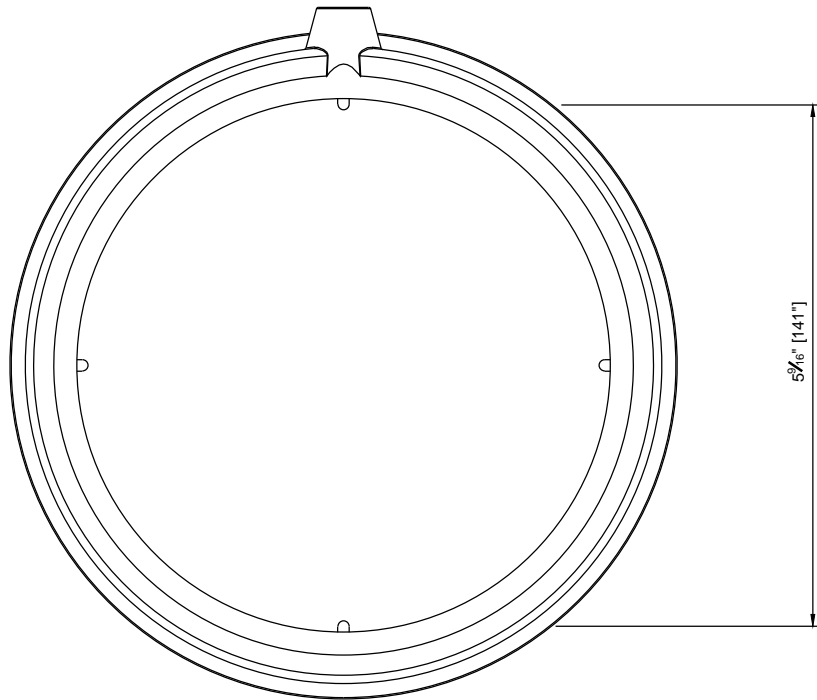
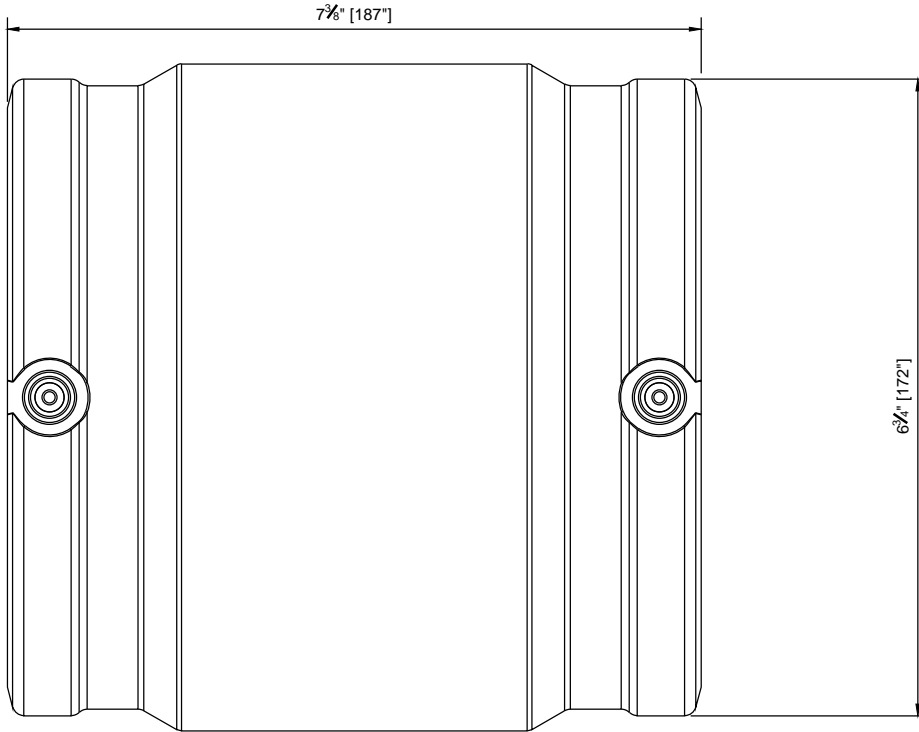

SDI 5" ELECTROFUSION COUPLER

PART NO.: 33404
 MATERIAL: HIGH DENSITY POLYETHYLENE
 MATERIAL MEETS ALL SPECIFICATIONS.
 SCALE: 6" = 1'-0"

NOTE: FOLLOW MANUFACTURE'S INSTALLATION PROCEEDURE

THESE DRAWINGS CONTAIN PROPRIETARY INFORMATION RESTRICTED SOLELY FOR USE ON THIS PROJECT. THESE DRAWINGS MAY NOT BE REPRODUCED IN WHOLE OR IN PART, FOR ANY OTHER USE WITHOUT THE EXPRESSED WRITTEN PERMISSION OF SCHWAGER DAVIS INC. (SDI). SDI DOES NOT MAKE ANY JUDGMENT NOR WARRANTY, EXPRESSED OR IMPLIED, AS TO THE ADEQUACY OF THE STRUCTURAL DESIGN BY OTHERS AND HEREBY DISCLAIMS ANY LIABILITY FOR DESIGNS OF OTHERS.

SDI 5" ELECTROFUSION COUPLER

SCHWAGER DAVIS, INC.
 POST-TENSION SYSTEM LIBRARY



SCHWAGER DAVIS, INC.
 DESIGN-BUILD CONTRACTOR
 198 HILLSDALE AVENUE
 SAN JOSE, CA 95136
 PHONE: 408.281.9300
 FAX: 408.281.9301
 www.schwagerdavis.com

DRAWING No: SDI-HD-374

#	REVISIONS	DRAWN	CHECKED	APPROVED	DATE
0	RELEASE	JSA	MSC	MSC	8-09-18

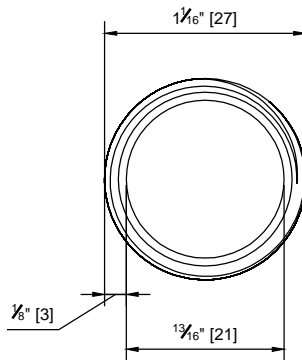
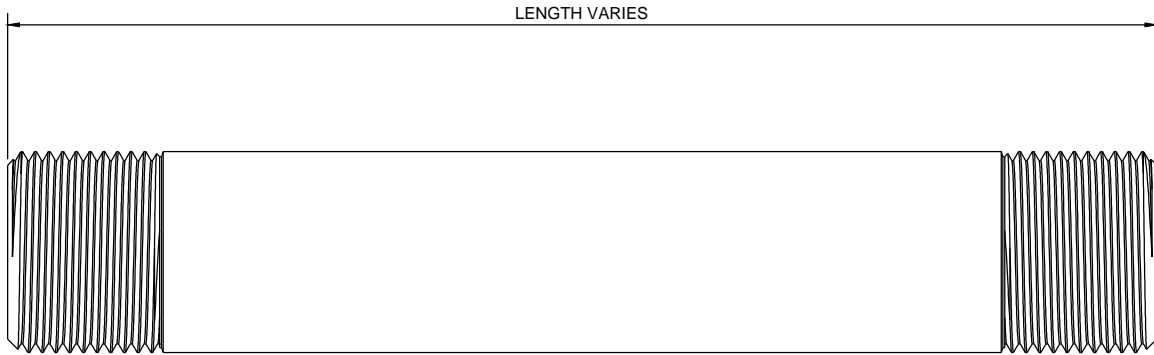

3/4" NPT PIPE NIPPLE

PART NO.: 51005
 MATERIAL: HIGH DENSITY POLYETHYLENE
 PRESSURE RATING: 150 PSI
 MATERIAL MEETS ALL SPECIFICATIONS.
 SCALE: 1'-0" = 1'-0"

THESE DRAWINGS CONTAIN PROPRIETARY INFORMATION RESTRICTED SOLELY FOR USE ON THIS PROJECT. THESE DRAWINGS MAY NOT BE REPRODUCED IN WHOLE OR IN PART, FOR ANY OTHER USE WITHOUT THE EXPRESSED WRITTEN PERMISSION OF SCHWAGER DAVIS INC. (SDI). SDI DOES NOT MAKE ANY JUDGMENT NOR WARRANTY, EXPRESSED OR IMPLIED, AS TO THE ADEQUACY OF THE STRUCTURAL DESIGN BY OTHERS AND HEREBY DISCLAIMS ANY LIABILITY FOR DESIGNS OF OTHERS.

3/4" NPT PIPE NIPPLE
 (HDPE)

SCHWAGER DAVIS, INC.
 POST-TENSION
 SYSTEM LIBRARY



SCHWAGER DAVIS, INC.
 DESIGN-BUILD CONTRACTOR
 198 HILLSDALE AVENUE
 SAN JOSE, CA 95136
 PHONE: 408.281.9300
 FAX: 408.281.9301
 www.schwagerdavis.com

DRAWING No: SDI-HD-363					
#	REVISIONS	DRAWN	CHECKED	APPROVED	DATE
0	RELEASE	JSA	MSC	MSC	06/18/18

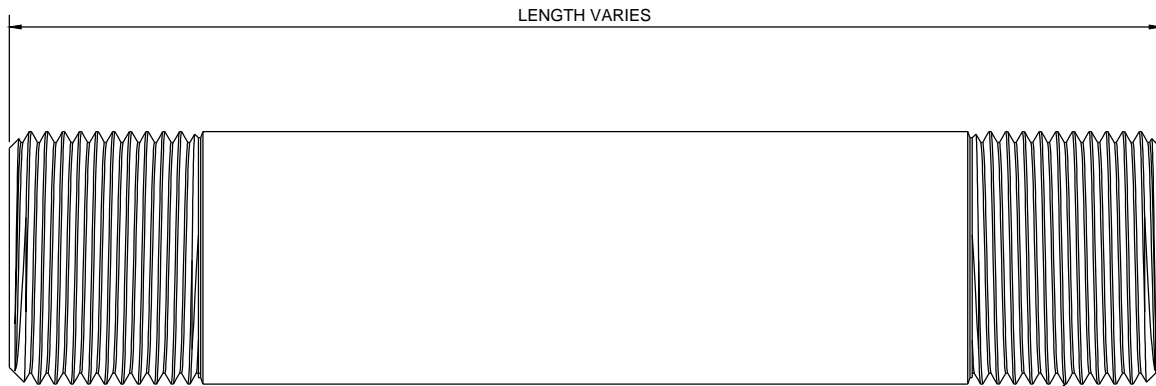

1 NPT PIPE SIZE, 11½ THREADS PER INCH,
0.68" THREAD ENGAGEMENT

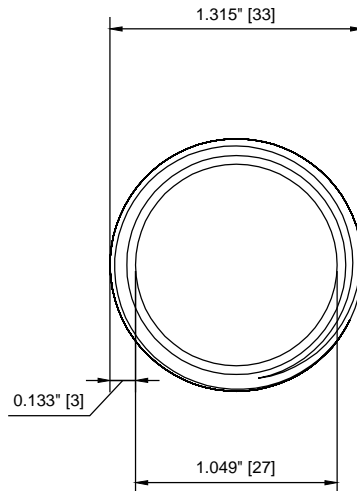

1" NPT PIPE NIPPLE (TEMPORARY)

PART NO.: 51003
 MATERIAL: STEEL, ASTM A53
 THREADS PER ANSI/ASME B1.20.1
 PRESSURE RATING 150 PSI
 MATERIAL MEETS ALL SPECIFICATIONS.
 SCALE: 1'-0" = 1'-0"

THESE DRAWINGS CONTAIN PROPRIETARY INFORMATION RESTRICTED SOLELY FOR USE ON THIS PROJECT. THESE DRAWINGS MAY NOT BE REPRODUCED IN WHOLE OR IN PART, FOR ANY OTHER USE WITHOUT THE EXPRESSED WRITTEN PERMISSION OF SCHWAGER DAVIS INC. (SDI). SDI DOES NOT MAKE ANY JUDGMENT NOR WARRANTY, EXPRESSED OR IMPLIED, AS TO THE ADEQUACY OF THE STRUCTURAL DESIGN BY OTHERS AND HEREBY DISCLAIMS ANY LIABILITY FOR DESIGNS OF OTHERS.

1" NPT PIPE NIPPLE

SCHWAGER DAVIS, INC.
 POST-TENSION
 SYSTEM LIBRARY



SCHWAGER DAVIS, INC.
 DESIGN-BUILD CONTRACTOR
 198 HILLSDALE AVENUE
 SAN JOSE, CA 95136
 PHONE: 408.281.9300
 FAX: 408.281.9301
 www.schwagerdavis.com

DRAWING No: SDI-HD-269

#	REVISIONS	DRAWN	CHECKED	APPROVED	DATE
0	RELEASE	CSM	MSC	MSC	06/07/16
1	UPDATE	JSA	MSC	MSC	06/18/18



Technical Product Information

RED-i PT CABLE COATING GREASE

RED-i PT CABLE COATING IS SPECIALLY FORMULATED FOR THE POST TENSIONING CONSTRUCTION INDUSTRY, AND EXCEEDS THE POST TENSIONING INSTITUTE (PTI) SPECIFICATIONS IN CORROSION PROTECTION FOR UNBONDED AND SINGLE-STRAND TENDONS IN CORROSIVE SERVICE.



Product Description: RED-i PT CABLE COATING is a premium lithium grease fortified with effective corrosion inhibitors. The coating is specifically designed to provide extended protection against corrosion of metal cables or any metallic surface exposed to moisture.

Features:

- Adhesive properties protects metal surfaces from air, moisture, and sea water.
- Excellent corrosion and rust inhibition properties.
- Exceeds PTI specifications.
- Member Post Tensioning Institute.
- High dropping point.
- Contains antimicrobial agent.

Typical Uses:

- Preserves metallic cables and wires exposed to corrosive environments.
- Preserves steel reinforcement bars or rods used for concrete structures against corrosion.
- Recommended for use in marine and construction industries.

Typical Specifications:

GRADE, NLGI	2
Penetration @ 77° F. (ASTM Worked)	265-295
Dropping Point, ASTM D-2265, °F.	383
Color	Amber
Texture	Butter
Appearance	Smooth
Soap Type	Lithium
Soap, %	7.0
Rust Test, ASTM D-1743	Pass
Corrosion Test, ASTM B-117	Pass (No Rust)
Soak Test, ASTM B-117 Modified	Pass
Emulsification Of Coating	None
Oil Separation, FTM 321.2 , Wt.%	0.5
Flash Point, ASTM D-92, Coc, °F	350
Water Content, ASTM D-95, Wt.%	<0.1
Base Oil Viscosity	
cSt. @ 40° C.	321.0
cSt. @ 100° C.	21.0
SUS@100° F.	74
Viscosity Index	<0.5
Chlorides, PPM ASTM D-512	<0.1
Nitrates, PPM, ASTM D3867	8.54
Tensile Strength Change Of Polymer, ASTM D638	

VALUES SHOWN HERE ARE TYPICAL AND MAY VARY.

SET High Strength Epoxy-Tie® Anchoring Adhesive

SET Epoxy-Tie® epoxy is a two-component, 1:1 ratio, high solids, epoxy-based adhesive for use as a high strength, non-shrink anchor grouting material. Resin and hardener are dispensed and mixed simultaneously through the mixing nozzle. SET meets or exceeds the requirements of ASTM C-881 specification for Type I, II, IV and V, Grade 3, Class B and C.

GALLERY: ROLL OVER IMAGES BELOW TO SEE

LARGER IMAGE



SET22



EMN22i



EDT22B



SET-PAC EZ™
Adhesive
U.S. Patent
6,634,524



SET56



SET1.7KTA



USES

- Threaded-rod anchoring
- Rebar doweling
- Bonding hardened concrete to hardened concrete
- Pick-proof sealant around doors, windows and fixtures
- Paste-over for crack injection

CODE REPORTS

- ICC Evaluation Service [ESR-1772](#) (formerly ICBO-ES ER-5279) (PDF) (CMU & URM)
- City of L.A. [RR25279](#) (PDF)
- Caltrans approved
- Florida Statewide Product Approval [FL11506.4](#)
- [multiple DOT listings](#)
- [NSF/ANSI Standard 61 \(216 in²/1000 gal\)](#) (PDF), except SET1.7KTA
- SET-PAC EZ™ adhesive covered by ICC-ES, City of L.A. and NSF/ANSI listings only

The [load tables](#) list values based upon results from the most recent testing and may not reflect those in current code reports. Where code jurisdictions apply, consult the current

LINKS:

- [Supplemental Topics for Adhesive Anchors](#)
- [Estimating Guide](#)
- [Limited Warranty Information](#)
- [Tension and Shear Load Tables](#)
- [Load-Adjustment Factors](#)
- Documents:
 - [Anchor Catalog Section](#) (PDF)
 - [Product Submittal](#) (PDF)
 - [Material Safety Data Sheet: SET](#) (PDF)
 - [Material Safety Data Sheet: SET en Español](#) (PDF)
 - [SET-PAC-EZ™ Epoxy-Tie® Anchoring Adhesive Flier](#) (PDF)
 - [Rebar Yield and Tensile Strength Embedments Technical Bulletin](#) (PDF)
 - [Rebar Yield and Tensile Strength Embedments \(Canada\) Technical Bulletin](#) (PDF)
 - [Anchor Tension Loads in Masonry Chair Block Technical Bulletin](#) (PDF)
- Free Softw are:
 - [Anchor Designer](#)
 - [Adhesive Cartridge Quantity Estimator](#)

reports for applicable load values.

APPLICATION

Surfaces to receive epoxy must be clean. For installations in or through standing water, see Supplemental Topics for Adhesive Anchors for details. The base material temperature must be 40° F or above at the time of installation. For best results, material should be 70° - 80° F at the time of application. Cartridges should not be immersed in water to facilitate warming. To warm cold material, the cartridges should be stored in a warm, uniformly heated area or storage container for a sufficient time to allow epoxy to warm completely. Mixed material in nozzle can harden in 5-7 minutes at a temperature of 40° F or above.

TEST CRITERIA

Anchors installed with SET Epoxy-Tie® adhesive have been tested in accordance with ICC-ES's *Acceptance Criteria for Adhesive Anchors (AC58)* for the following:

- Seismic/wind loading
- Long-term creep at elevated-temperature
- Static loading at elevated-temperature
- Damp and water-filled holes
- Freeze-thaw conditions
- Critical and minimum edge distance and spacing

In addition, anchors installed with SET Epoxy-Tie® adhesive have been tested in accordance with ICC-ES's *Acceptance Criteria for Unreinforced Masonry Anchors (AC60)*.

PROPERTY	TEST METHOD	RESULTS
Consistency	ASTMC 881	Non-sag/ thixotropic paste
Heat deflection	ASTMD 648	136° F (58° C)
Bond strength (moist cure)	ASTMC 882	3,218 psi (2 days) 3,366 psi (14 days)
Water absorption	ASTMD 570	0.110% (24 hrs)
Compressive yield strength	ASTMD 695	5,065 psi (24 hours) 12,650 psi (7 days)
Compressive modulus	ASTMD 695	439,000 psi (7 days)
Gel time (75° F)	ASTMC 881	30 min - 60 gram mass 60 min - thin film

ACCESSORIES / RELATED PRODUCTS

- [Dispensing Tools](#)
- [Mixing Nozzles](#)
- [Plastic Anchoring Screens](#)
- [Steel Anchoring Screens](#)
- [Hole Cleaning Brushes](#)

SUGGESTED SPECIFICATIONS

Anchoring adhesive shall be a two-component high-solids epoxy based system supplied in manufacturer's standard cartridge and dispensed through a static-mixing nozzle supplied by the manufacturer. Epoxy shall meet the minimum requirements of ASTM C-881 specification for Type I, II, IV, and V, Grade 3, Class B and C and must develop a minimum 12,650 psi compressive yield strength after 7 day cure. Epoxy must have a heat deflection temperature of a minimum 136°F (58°C). Adhesive shall be SET Epoxy-Tie® adhesive from Simpson Strong-Tie, Pleasanton, CA. Anchors shall be installed per Simpson Strong-Tie instructions for SET Epoxy-Tie® adhesive.

ASD DESIGN EXAMPLE

For design example, [click here](#).

INSTALLATION

IMPORTANT For installation instructions, [click here](#).

SHELF LIFE

24 months from date of manufacture in unopened side-by-side cartridge. SET-PAC EZ™ cartridge - 24 months from date of manufacture, unopened.

STORAGE CONDITIONS

For best results store between 45° F - 90° F. To store partially used cartridges, leave hardened nozzle in place. To re-use, attach new nozzle.

COLOR

Resin – white, hardener – black
When properly mixed SET adhesive will be a uniform light gray color.

CLEAN UP

Uncured material – Wipe up with cotton cloths. If desired scrub area with abrasive, waterbased cleaner and flush with water. If approved, solvents such as ketones (MEK, acetone, etc.), lacquer thinner or adhesive remover can be used. **DO NOT USE SOLVENTS TO CLEAN ADHESIVE FROM SKIN.** Take appropriate precautions when handling flammable solvents. Solvents may damage surfaces to which they are applied. Cured material – Chip or grind off surface.

CHEMICAL RESISTANCE

Very good to excellent against distilled water, inorganic acids and alkalis. Fair to good against organic acids and alkalis, and many organic solvents. Poor against ketones. For more detailed information download [Technical Bulletin T-SAS-CHEMRES08](#) (PDF).

SET Cartridge Systems

Model No.	Capacity ounces (cubic inches)	Cartridge Type	Carton Quantity	Dispensing Tool(s)	Mixing ⁴ Nozzle
SET1.7KTA	1.7 (3.1)	side-by-side	12	Adaptor included for standard caulking tool	EMN1.7 (2 included)
SET-PAC-EZ	8.5 (16.2)	single	12	CDT10 or high quality standard caulking tool	2 included
SET22	22 (39.7)	side-by-side	10	EDT22B, EDT22AP, or EDT22CKT	EMN22i
SET56	56 (101.1)	side-by-side	6	EDT56AP	EMN22i or EMN50

1. Bulk containers also available, [contact Simpson Strong-Tie](#) for details.
2. [Cartridge and bulk estimation guides](#) are available.
3. [Detailed information](#) on dispensing tools, mixing nozzles and other adhesive accessories is available.
4. Use only appropriate Simpson Strong-Tie mixing nozzle in accordance with Simpson's instructions. Modification or improper use of mixing nozzle may impair epoxy performance.

Cure Schedule

Base Material Temperature		Cure Time
°F	°C	
40	4	72 hrs.
65	18	24 hrs.
85	29	20 hrs.
90	32	16 hrs.

In-Service Temperature Sensitivity

Base Material Temperature		Percent Allowable Load
°F	°C	
40	4	100%
70	21	100%
110	43	100%
135	57	75%
150	66	44%
180	82	20%

1. Refer to temperature sensitivity chart for allowable bond strength reduction for temperature. See [Supplemental Topics for Adhesive Anchors](#).
2. Percent allowable load may be linearly interpolated for intermediate base material temperatures.
3. $^{\circ}\text{C} = (^{\circ}\text{F} - 32) / 1.8$

top ▲



POLY-TEMP[®] MD MEDIUM DENSITY THREAD SEAL TAPE

WWW.ANTISEIZE.COM

Product Description

POLY-TEMP[®] MD Medium Density Thread Seal Tape is a general purpose PTFE Thread Seal Tape designed to be used on all types of metal and plastic pipe threads.

Our **POLY-TEMP[®]** Tapes are made from 99.9% virgin PTFE resins for optimum purity and performance. **POLY-TEMP[®] MD** Medium Density Thread Seal Tape is malleable to easily conform to thread profiles to ensure a positive seal.

Because **POLY-TEMP[®] MD** Medium Density Thread Seal Tape is composed of pure PTFE, it touts an extremely broad range of chemical compatibilities and is unaffected by most chemicals and concentrations.

POLY-TEMP[®] MD Medium Density Thread Seal Tape is our most popular grade of thread sealing tape and has been Industry Leader for over 30 years.

Features & Benefits

- Meets FDA and USDA requirements
- UL Listed
- Ideal for all taper thread connections
- PTFE's high lubricity makes for easy assembly
- Only 3 wraps need for most applications
- Chemically inert, non-Toxic
- Suitable for oxygen service
- Our most popular grade of Thread Seal Tape
- Easy to handle and apply
- Temperature range from -400F to 550F (-240C to 287C)
- Pressures up to 10,000psi (Liquid), 2000 psi (Gas)
- Connections can be put into service right away, no dry time
- Never dries out and an unlimited shelf life.
- Meets MIL-T-27730A
- Extremely versatile.

Typical Properties

Property	Value
Color	White
Thickness	3.5 mils
Specific Gravity	0.7 to 0.8g/cc
Toxicity	Non toxic
RoHS	Compliant

Cautions

Read all information on labels and Material Safety Data Sheets prior to use. All products should be tested and evaluated for a particular purpose prior to use.

Product Limited Warranty

This information is based on information we believe to be reliable and accurate, but no guarantee of its accuracy is made for a particular application. We urge and recommend that Users pretest their application prior to incorporating the product into use and assume that the User will conduct such testing. Also see warranty statement on website.

Available In:

Size: 1/2"x 60" 1/4"x520" 1/2"x260" 1/2"x520" 1/2"x1296"
P/N: 16006 16025 16030 16035 16040

Size: 3/4"x260" 3/4"x520" 1"x260" 1"x520"
P/N: 16045 16050 16055 16060

Size: Counter Display 1/2"x260" 1/2"x520" 3/4"x520"
P/N: 16030A 16035A 16050A

POLY-TEMP[®] IS A REGISTERED TRADEMARK OF ANTI-SEIZE TECHNOLOGY

ANTI-SEIZE TECHNOLOGY

2345 N. 17th AVE. • FRANKLIN PARK, IL 60131-3432
847-455-2300 • www.antiseize.com