

CAUTION

Assembly of anchorage and installation of tendons shall only be performed by qualified post-tensioning specialist personnel.

This installation procedure is generic; follow the specific procedure for each project and the FDoT specifications.

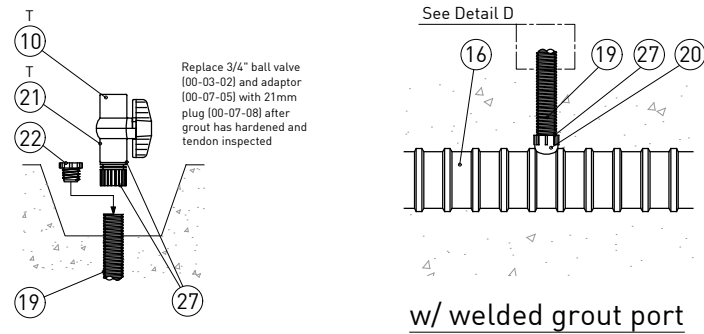

DETAIL D

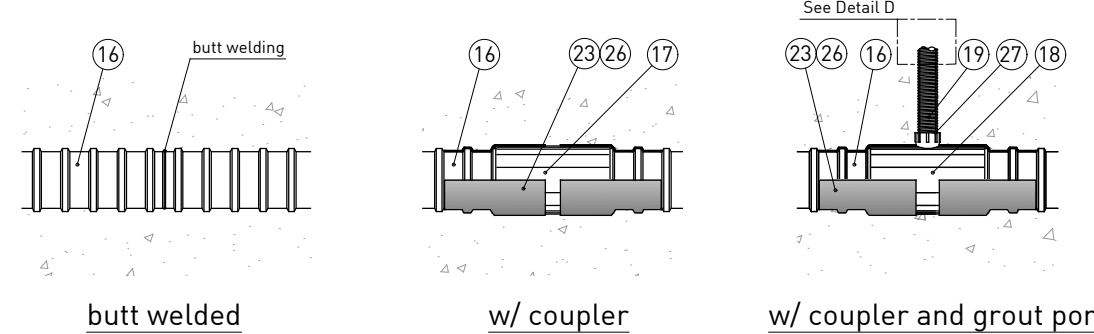

INTERMEDIATE COUPLING DETAILS

see installation procedures

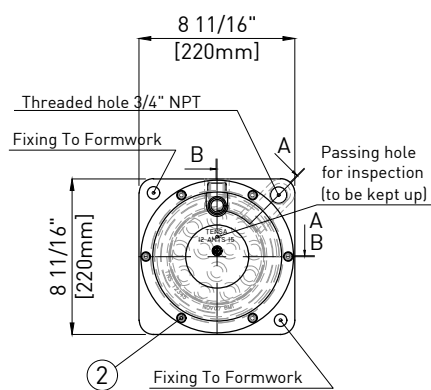

END VIEW

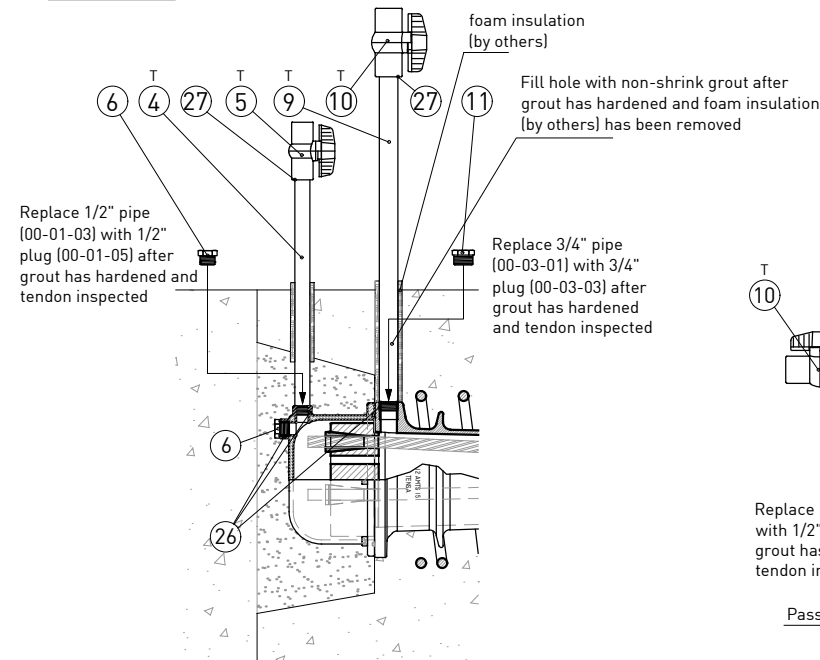

SECTION B-B
top injection and venting

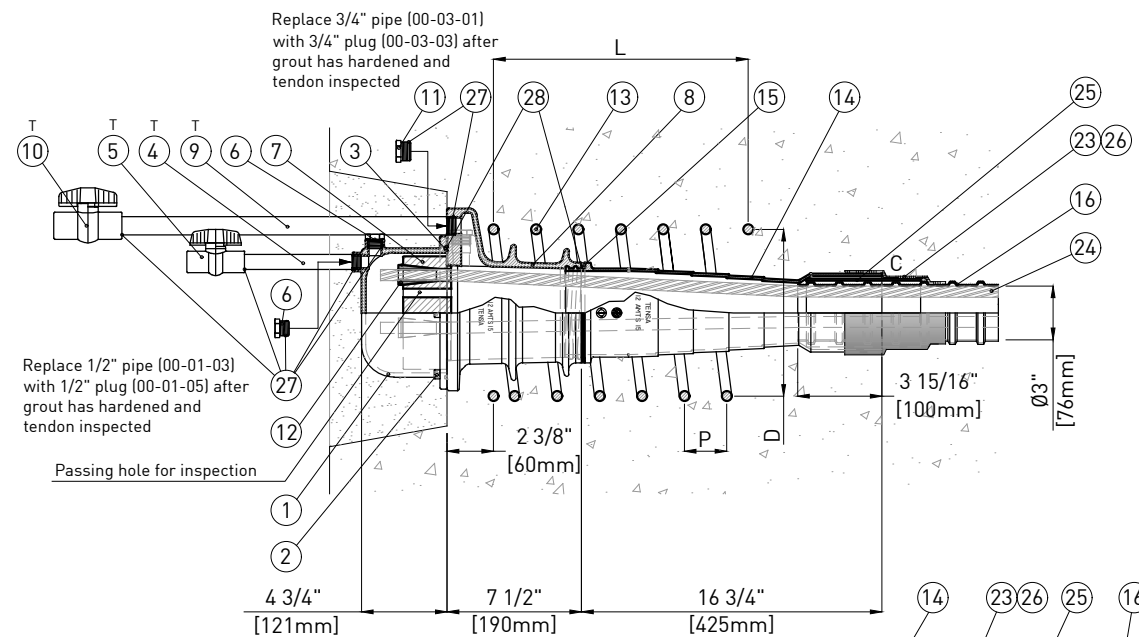

SECTION A-A
front injection and venting

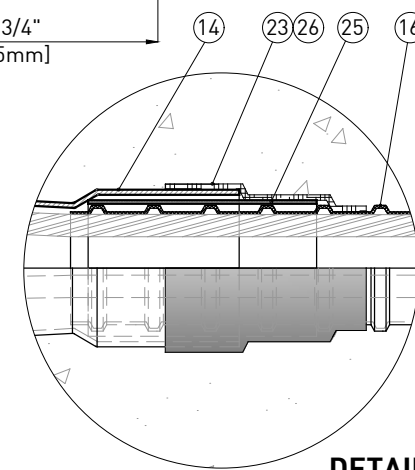

DETAIL C

INSTALLATION

1. Preassemble anchor (AN) and plastic trumpet (PT), (some silicone grease shall be used to facilitate the threading and the compression of the gasket).
2. Bolt the assembled AN to the pocket former using the two threaded holes located on the front surface of AN. AN shall be placed perpendicular to the tendon's axis and rotated such as the side grout hole points up.
3. The position of the spiral rebar (SR) shall be secured to the AN or to adjacent rebar by tack-welding or proper fixing. The SR shall be rotated such that it won't interfere with 3/4" NPT pipe attachment (if using side grout hole). Align axis of SR with AN. Seal unused port in AN.
4. Install the duct as shown on shop drawings and insert it into PT and seal it with duct by heat shrink sleeve (or, if not possible, with heat shrink wrap) in order to prevent concrete from penetrating.
5. Carry out the pressure test.

Concreting can now proceed.

6. After completion of concrete placement, remove the pocket former and prove that duct is clear of any obstructions or damage and that all grout vents are free and secured.
7. Install strands by pushing or pulling individually or as a bundle into duct. Allow sufficient extra length at the active anchorage for stressing. The strand threading can be completed before or after the concrete is poured.
8. Check the wedge plate (WP) for rust and dirt, clean wedge holes with wire brush if necessary. Lightly grease or oil wedge holes.
9. Check wedges for rust. Discard rusty wedges and use only clean ones.
10. Install wedge plate (keeping up the inspection hole), slip the wedges over the strands and securely place them into wedge holes.
11. Do not apply post-tensioning forces until the concrete mean compressive strength f_{ci} is not less than the values shown on the spiral table. These values refer to cylindrical strength.

Stressing can now proceed.

[!] Appropriate clearance must be kept behind the hydraulic jack while stressing.

12. Stressing operation shall be executed according to the engineer form and requires the simultaneous reading of pressure and elongation. Check the conformity of the final elongations measurement with prescribed values.
 13. Install the protection cap (PC) with O-ring sealing on AN using six bolts (some silicone grease shall be used to facilitate the compression of the O-ring).
 14. Thread 1/2" NPT pipe for grout onto the PC and the 3/4" NPT pipe for grout onto AN. Use a 1/2" plug to secure the hole on PC not used. (Some thread seal tape shall be used to improve the tightness of the threadings).
 15. Carry out the pressure test.
- Grouting can now proceed.
16. Grout shall be injected through the filler inlet until it escapes from the filler outlet. Special measures shall be applied for long tendons, for tendon paths with distinct high points or inclined tendons to avoid voids.
 17. All vents and grouting inlets/outlets have to be sealed with plugs soon after grouting.
 18. Fill holes with non-shrink grout after post grouting operation and inspection are completed.

BILL OF MATERIALS

ITEM	PART #	DESCRIPTION	MATERIAL
1	12-01-00	Protection Cap	Nylon S-PA0401 - according to ASTM D5989
2	12-01-01	Protection Cap Bolts	Stainless Steel GR316L - according to ASTM F593
3	12-01-02	Protection Cap O-Ring	NBR - according to FDoT Tab.2.2.1.7-1 Sec.960
4	00-01-03	NPT Pipe Nipple 1/2"	SCH80 PVC or SCH40 steel
5	00-01-04	NPT Ball Valve 1/2"	PVC 150 psi rated
6	00-01-05	NPT Plug 1/2"	High Density Polyethylene - according to ASTM D3350
7	I-12-02-00	Wedge Plate	Steel AISI C1045 Normalized
8	12-03-00	Anchor	Ductil Iron ASTM A536 GR80-55-06 + Galvanization according to ASTM A123
9	00-03-01	NPT Pipe Nipple 3/4"	SCH80 PVC or SCH40 steel
10	00-03-02	NPT Ball Valve 3/4"	PVC 150 psi rated
11	00-03-03	NPT Plug 3/4"	High Density Polyethylene - according to ASTM D3350
12	00-04-00	Wedges	Steel AISI 12L14 - according to ASTM A108 + Heat treatment
13	12-05-00	Spiral	Steel GR60, #4 - according to ASTM A615
14	12-06-00	Trumpet	High Density Polyethylene - according to ASTM D3350
15	12-06-01	Compression Seal	NBR - according to FDoT Tab.2.2.1.7-1 Sec.960
16	I-12-07-00	Duct 3.00"	Polypropylene - according to ASTM D4101
17	I-12-07-01	Duct Coupler 3.00"	Polypropylene - according to ASTM D4101
18	I-12-07-02	Duct Coupler w/ Vent 3.00"	Polypropylene - according to ASTM D4101
19	00-07-03	Hose 21mm	Polyethylene - according to ASTM D3350
20	00-07-04-P	Vent Port 21mm PP	Polypropylene - according to ASTM D4101
21	00-07-05	Adaptor 21mm-3/4"	Polypropylene - according to ASTM D4101
22	00-07-08	21mm Plug	High Density Polyethylene - according to ASTM D3350
23	12-07-06	Heat Shrink Sleeve	Coated Polyolefin Backing - according to FDoT Tab.2.2.1.8-1 Sec.960
24	00-08-00	Strand 0.6"	Steel GR270 - according to ASTM A416
25	12-07-07	Duct Coupler 3.00" stepless	Polypropylene - according to ASTM D4101
26	00-09-00	Heat Shrink Wrap	Coated Polyolefin Backing - according to FDoT Tab.2.2.1.8-1 Sec.960

NOTE:

- Components marked with "T" on the drawing are temporary;
- Port and hose assembly may be oriented in any required direction to create a vent or a drain.
- Epoxy grout shall be used to fill recesses: make reference to FDoT standard plans index 462-003 for post-tensioning anchorage and tendon filling details
- Concrete cover must meet FDoT Structures Design Guidelines Section 1.4.2

MISCELLANEOUS MATERIALS	
ITEM	DESCRIPTION
27	Commercially available thread seal tape
28	Commercially available and compatible silicone grease

SPIRAL		
CONCRETE CLASS	4000PSI [27.5MPA]	6500 PSI [45MPA]
LENGTH (L)	13-5/8" [345mm]	
DIAMETER (D)	12-5/8" [322mm]	9-1/2" [242mm]
PITCH (P)	2-3/8" [60mm]	
BAR DIAMETER	#4 - 1/2" [13mm]	
N. OF TURNS	7.5	

0	07/04/18	First issue	L.C.	T.C.
Rev.	Date	Description	Drawn	Checked

Material :	Treatment :
-	-

		INTERNAL PT SYSTEM ASSEMBLY for 12AMTS15 (12-0.6")	
TENSA AMERICA LLC - www.tensaamerica.com - PHONE: +1 305-866-9917 1111 KANE CONCOURSE, S. TE 200 - BAY HARBOR ISLAND - 33154 FL		Drawn : L.CIVATI	Checked : T.CICCONO
Date : 07/04/2018	Dimensions : <small>(INCH [mm])</small> FOR REFERENCE ONLY	Part # : I-12-00-00	Code : -

Document Property of TENSA AMERICA LLC
This drawing contains proprietary information restricted solely for use on this project and may not be reproduced in whole or in part. For any other use without the expressed written permission of TENSA AMERICA LLC, the company will safeguard its rights according to the civil and penal provisions of the Law.

BOTTOM VIEW

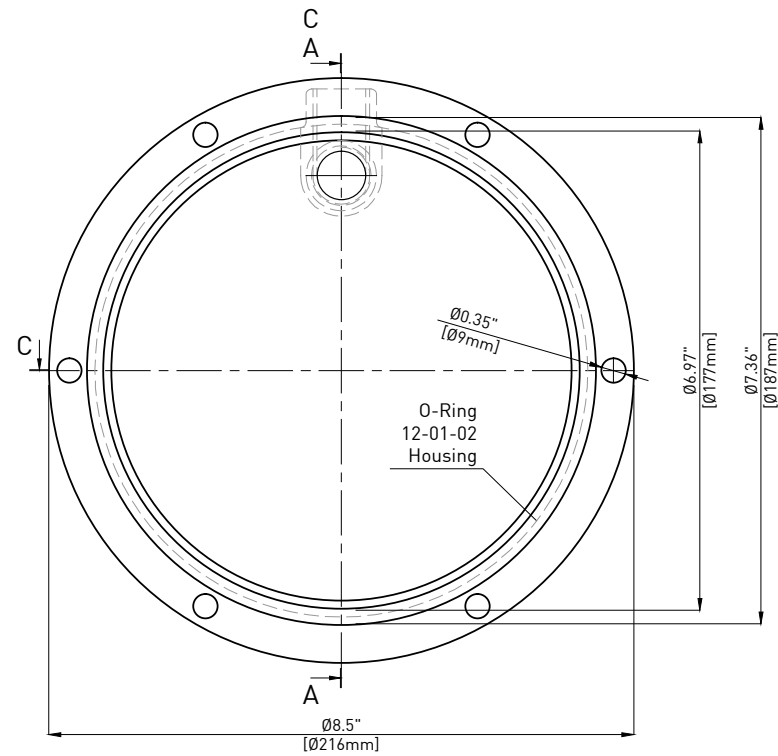

SECTION A-A

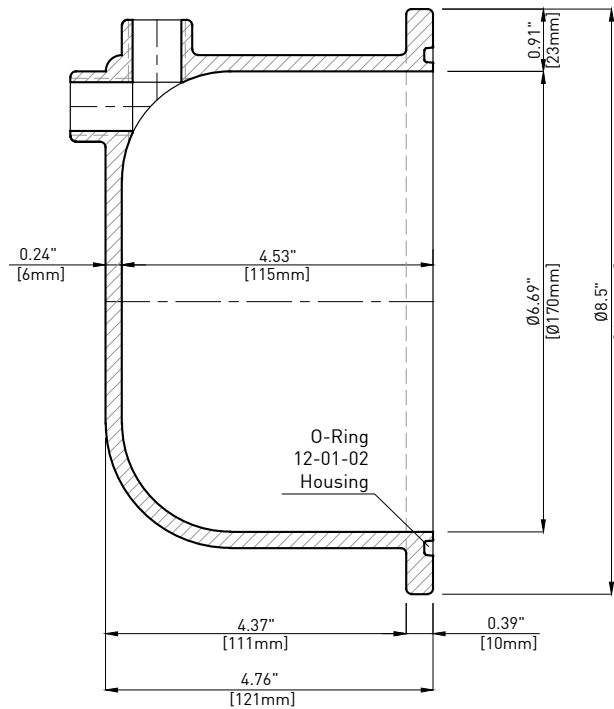

SECTION C-C

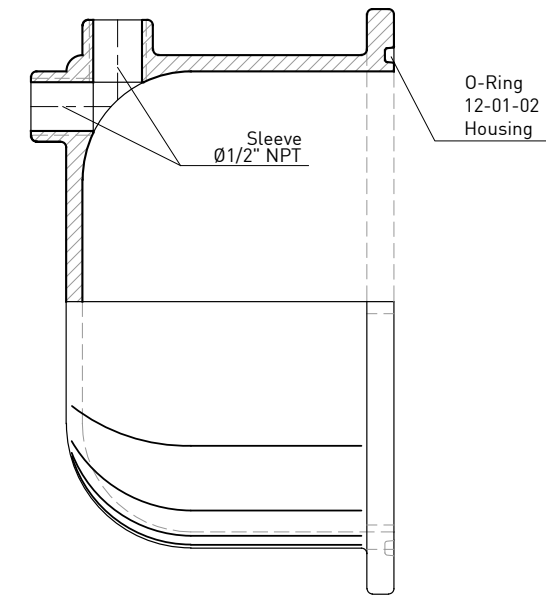

TOP VIEW

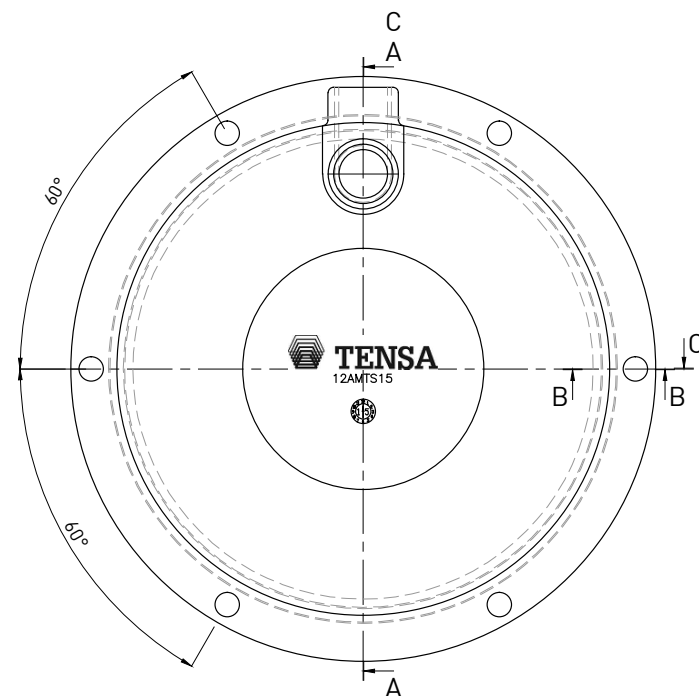

SECTION B-B

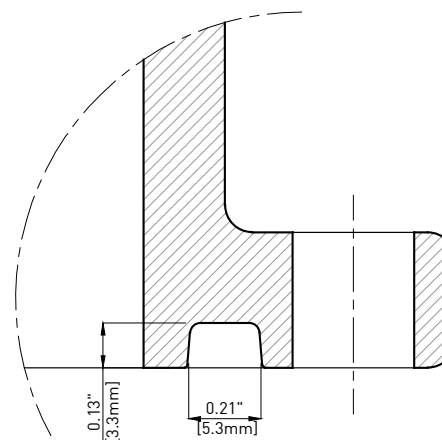

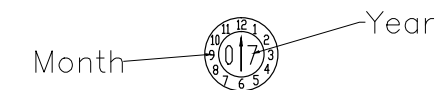

Marking – Type

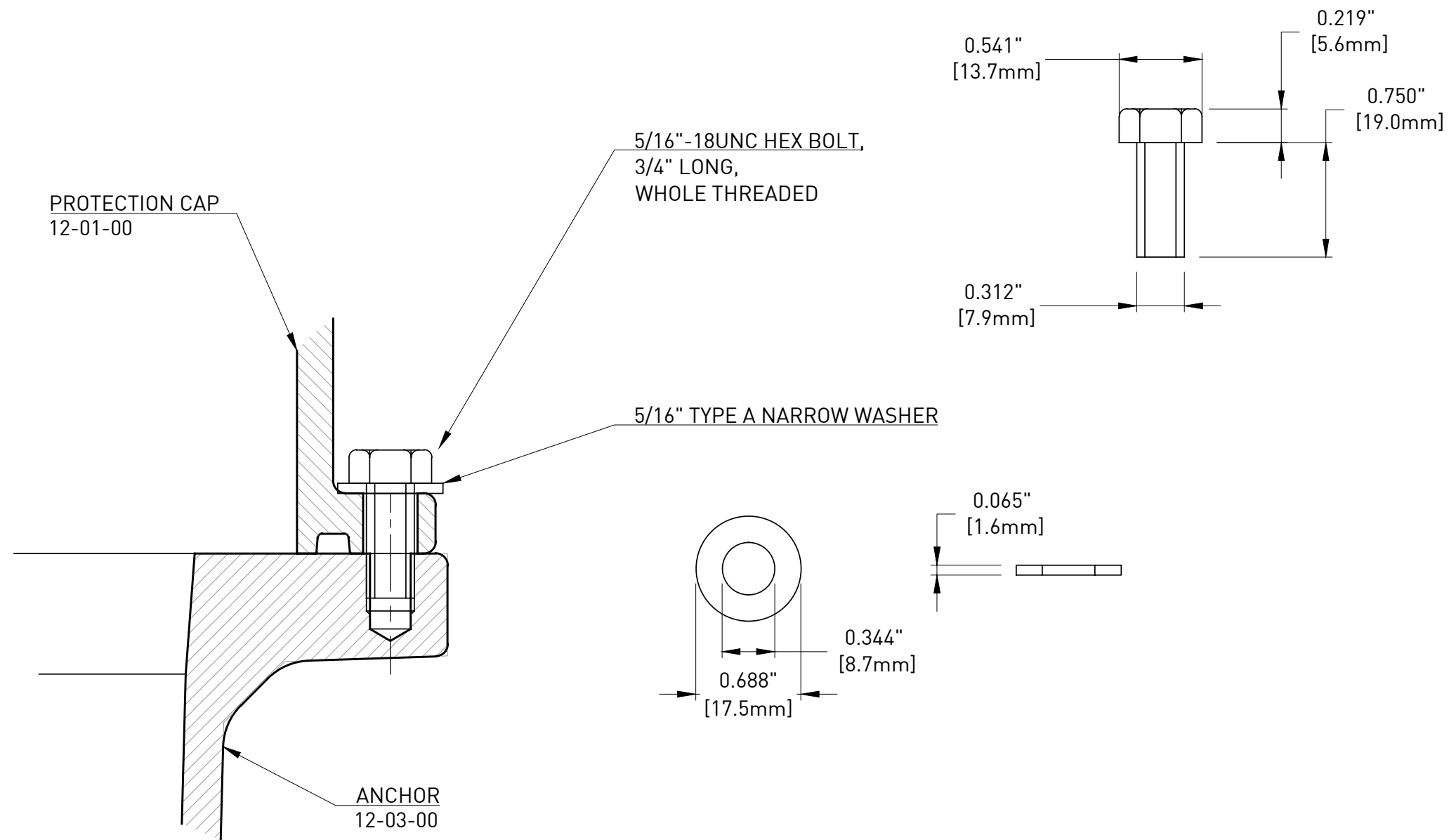

Material : Nylon S-PA0401 - according to ASTM D5989		Treatment : -	
 TENZA AMERICA GRUPPO DE ECCHER		Title : PROTECTION CAP for 12AMTS15	
		Drawn : L.CIVATI	Checked : T.CICCONO
Date : 12/20/2016	Dimensions : <small>INCH (mm) mm FOR REFERENCE ONLY</small>	Part # : 12-01-00	Code : -
<small>Document Property of TENZA AMERICA LLC This drawing contains proprietary information restricted solely for use on this project and may not be reproduced in whole or in part. For any other use without the expressed written permission of TENZA AMERICA LLC, the company will safeguard its rights according to the civil and penal provisions of the Law.</small>			

0	12/20/16	First issue	L.C.	T.C.
Rev.	Date	Description	Drawn	Checked



Material : Stainless Steel GR316L - according to ASTM F593		Treatment : -	
 TENSA AMERICA GRUPPO DE ECCHER		Title : PROTECTION CAP BOLTS for 12AMTS15	
		Tensa America LLC - www.tensaamerica.com - PHONE: +1 305-866-9917 1111 KANE CONCOURSE, S.TE 200 - BAY HARBOR ISLAND - 33154 FL	Drawn : F.MORAGLIA
Date : 12/20/2016	Dimensions : <small>INCH [mm] mm FOR REFERENCE ONLY</small>	Part # : 12-01-01	Code : -

Rev.	Date	Description	Drawn	Checked
0	12/20/16	First issue	F.M.	T.C.

Document Property of Tensa America LLC
 This drawing contains proprietary information restricted solely for use on this project and may not be reproduced in whole or in part. For any other use without the expressed written permission of Tensa America LLC, the company will safeguard its rights according to the civil and penal provisions of the Law.

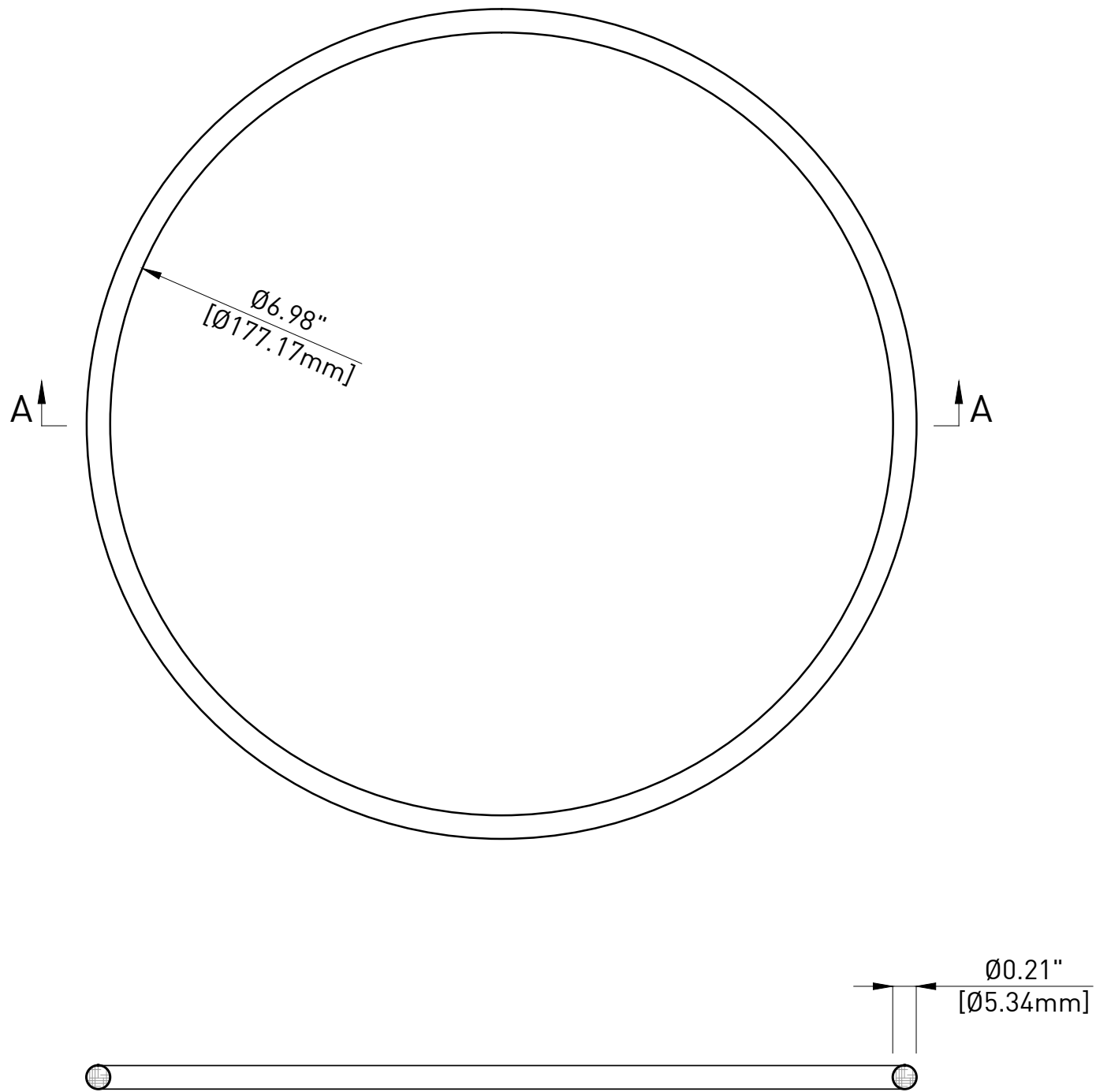



SECTION A-A

NOTE:

- This drawing is not intended for manufacturing purposes.

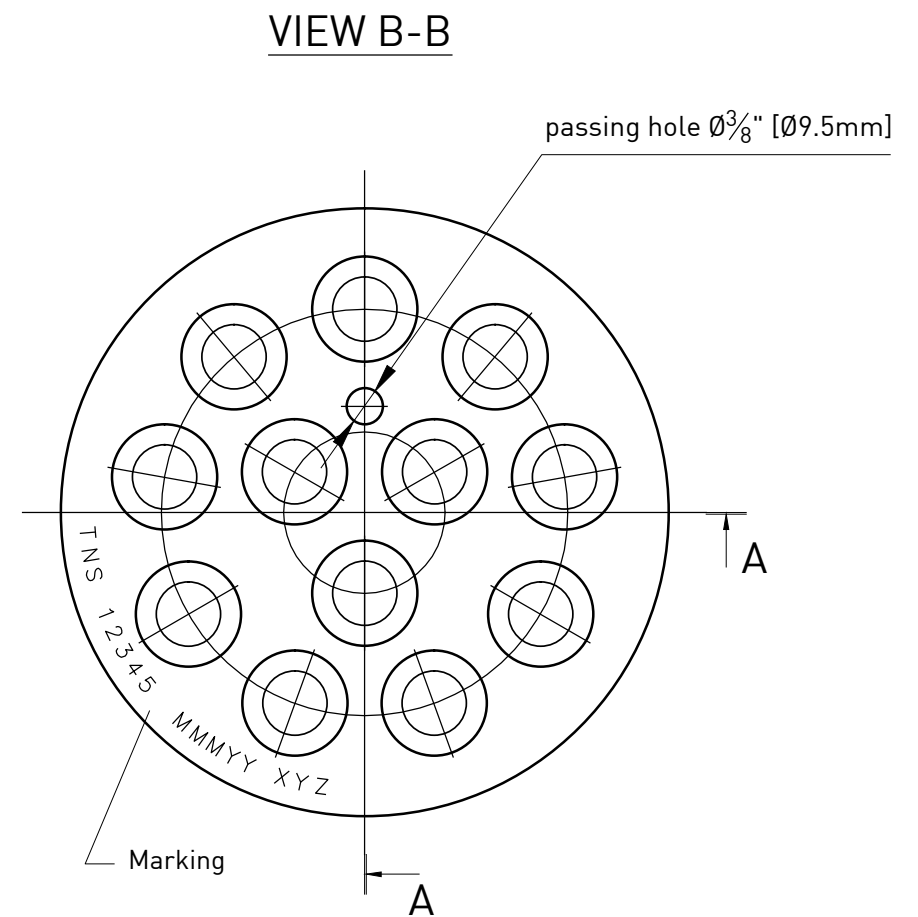
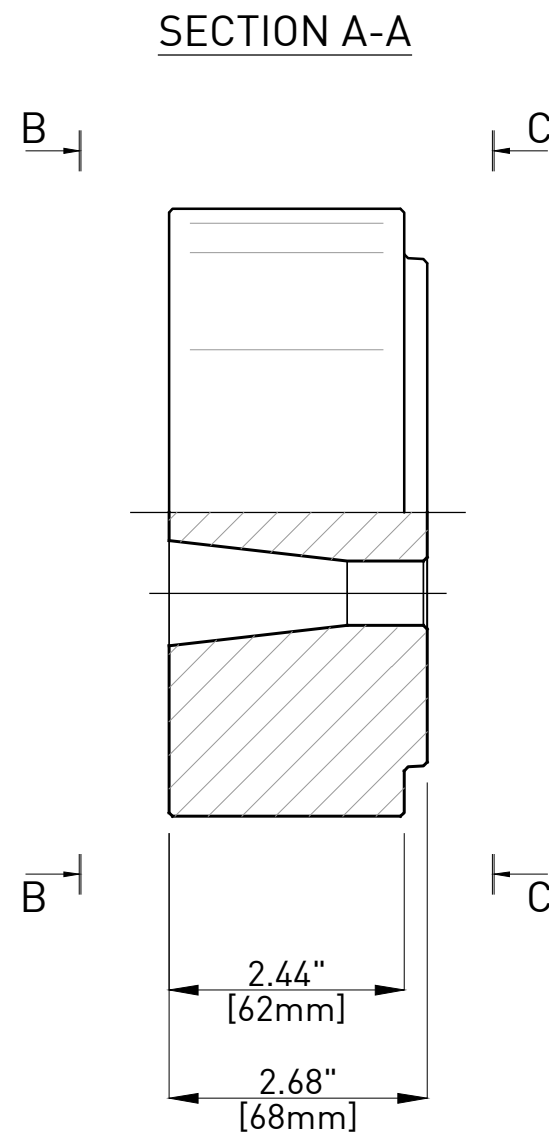
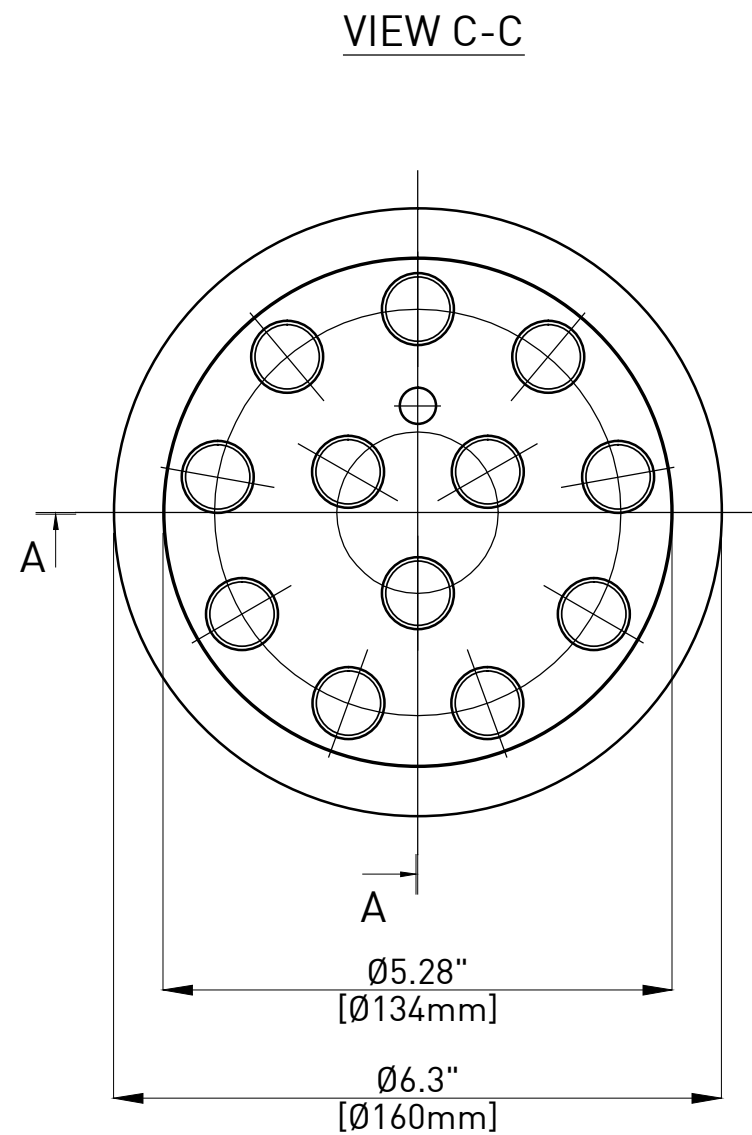
0	12/20/16	First issue	L.C.	T.C.
Rev.	Date	Description	Drawn	Checked
Material : NBR - according to FDOT Tab. 2.2.1.7-1 Sec.960		Treatment : -		
		Title : Centro Guarnizioni TIGER s.r.l PROTECTION CAP O-RING for 12AMTS15 PT SYSTEM		
TENZA AMERICA LLC - www.tensaamerica.com - PHONE: +1 305-866-9917 1111 KANE CONCOURSE, S.TE 200 - BAY HARBOR ISLAND - 33154 FL		Drawn : L.CIVATI	Checked : T.CICCONE	
Date : 12/20/2016	Dimensions : <small>INCH [mm]</small> <small>mm FOR REFERENCE ONLY</small>	Part # : 12-01-02	Code : OR 06700	
<small>Document Property of TENSA AMERICA LLC</small> <small>This drawing contains proprietary information restricted solely for use on this project and may not be reproduced in whole or in part. For any other use without the expressed written permission of TENSA AMERICA LLC, the company will safeguard its rights according to the civil and penal provisions of the Law.</small>				



Material : Steel AISI C1045 Normalized		Treatment : -	
 TENSA AMERICA <small>GRUPPO DE ECCHER</small>		WEDGE PLATE for 12AMTS15 (12-06") Internal Bonded System	
TENSA AMERICA LLC - www.tensaamerica.com - PHONE: +1 305-866-9917 1111 KANE CONCOURSE, S. TE 200 - BAY HARBOR ISLAND - 33154 FL		Drawn : F.MORAGLIA	Checked : T.CICCONE
Date : 12/20/2016	Dimensions : <small>INCH [mm]</small> <small>mm FOR REFERENCE ONLY</small>	Part # : I-12-02-00	Code : -
<small>Document Property of TENSA AMERICA LLC</small> <small>This drawing contains proprietary information restricted solely for use on this project and may not be reproduced in whole or in part. For any other use without the expressed written permission of TENSA AMERICA LLC, the company will safeguard its rights according to the civil and penal provisions of the Law.</small>			

Rev.	Date	Description	Drawn	Checked
0	12/20/16	First issue	F.M.	T.C.

SECTION A-A

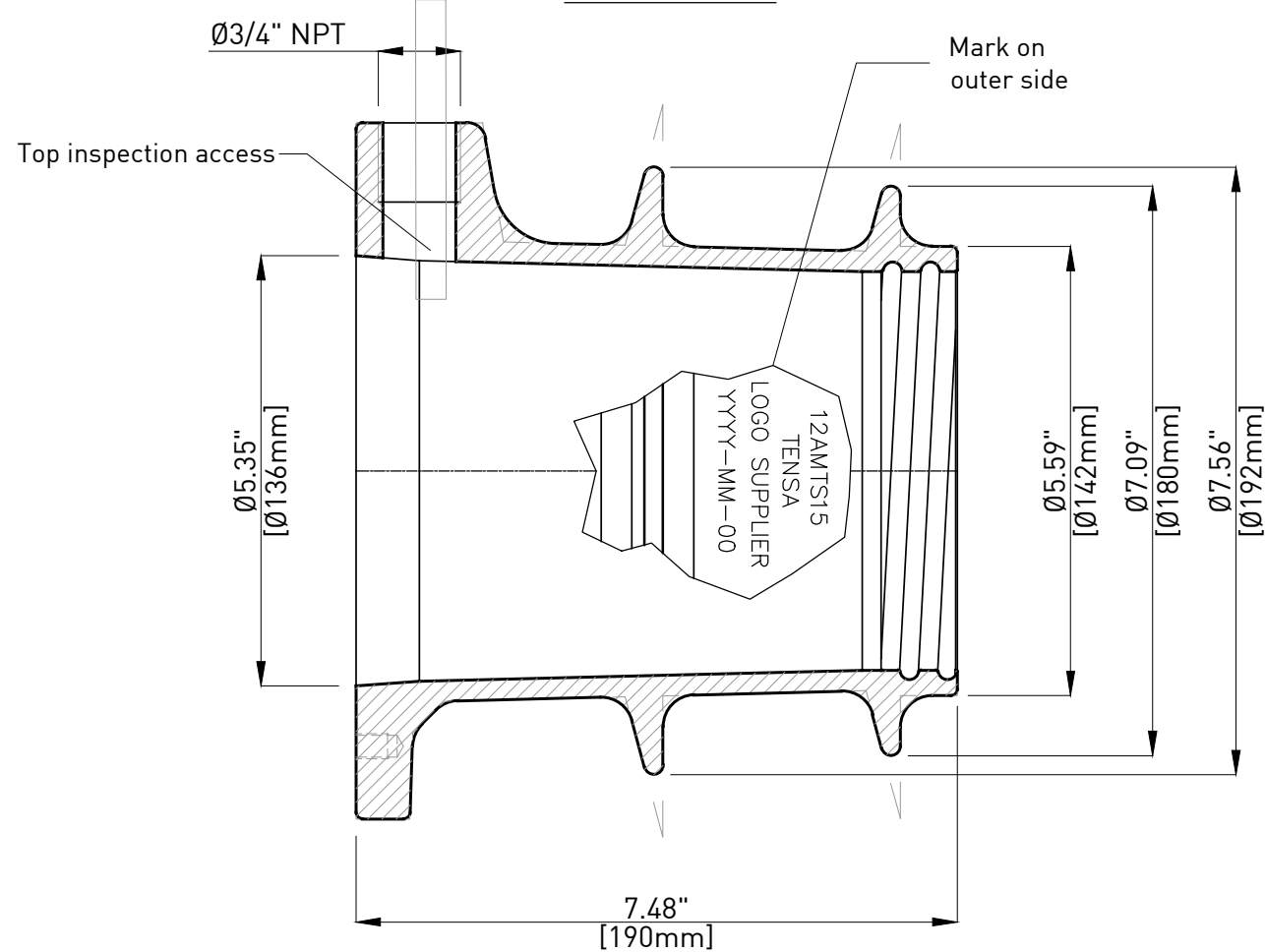

FRONT VIEW

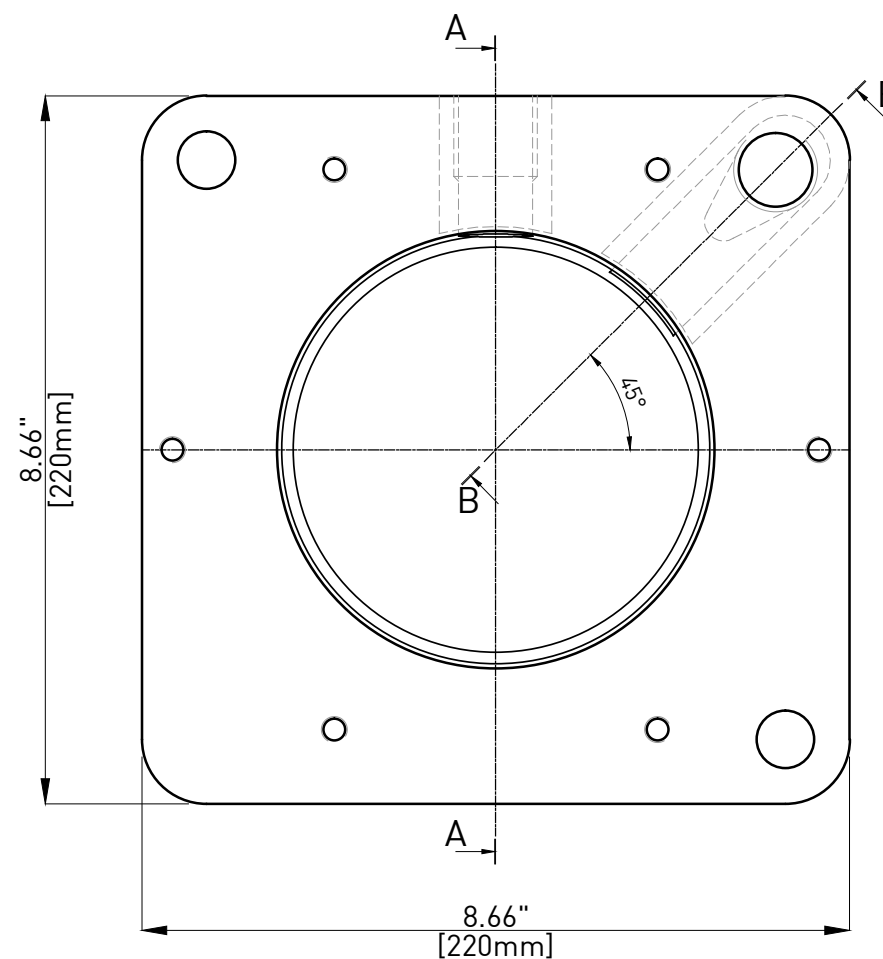

SECTION B-B

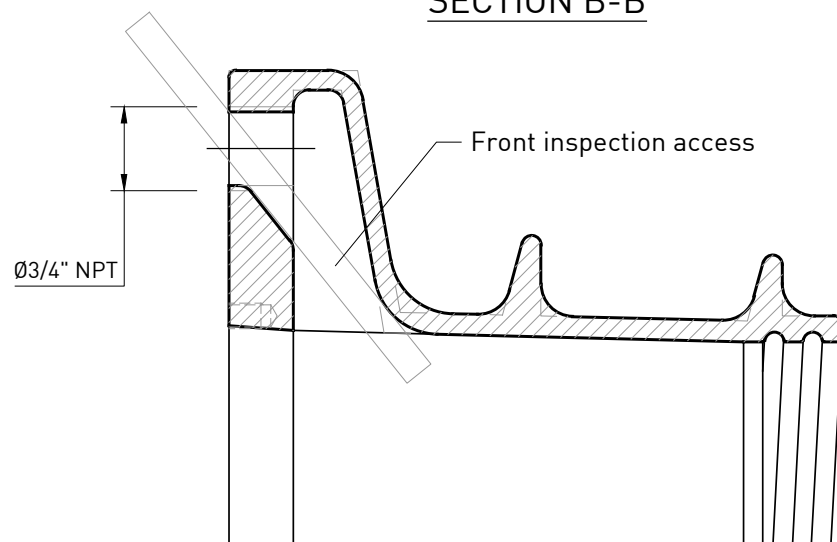

Material : Ductil Iron ASTM A536 GR80-55-06		Treatment : Galvanization according to ASTM A123	
		Title : ANCHOR 12AMTS15 (12-0.6")	
		TENSA AMERICA LLC - www.tensaamerica.com - PHONE: +1 305-866-9917 1111 KANE CONCOURSE, S.TE 200 - BAY HARBOR ISLAND - 33154 FL	
Date : 12/20/2016	Dimensions : <small>INCH [mm] mm FOR REFERENCE ONLY</small>	Drawn : F.MORAGLIA	Checked : T.CICCONE
Date : 12/20/2016		Part # : 12-03-00	Code : -

0	12/20/16	First issue	F.M.	T.C.
Rev.	Date	Description	Drawn	Checked

Document Property of TENSA AMERICA LLC
This drawing contains proprietary information restricted solely for use on this project and may not be reproduced in whole or in part. For any other use without the expressed written permission of TENSA AMERICA LLC, the company will safeguard its rights according to the civil and penal provisions of the Law.

STANDARD SPIRAL
FOR CONCRETE CLASS $f'_{ci} = 4000\text{psi}$ [27.5MPa] *

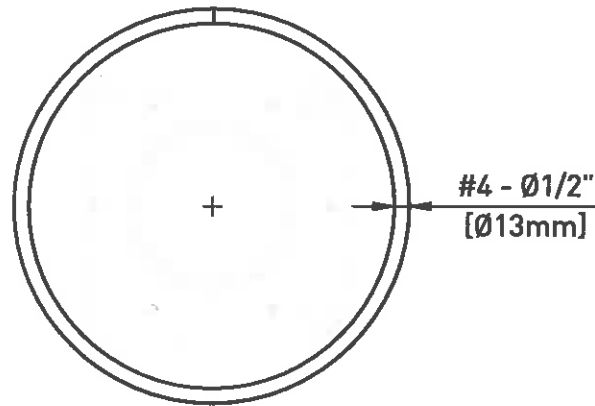

STANDARD SPIRAL
FOR CONCRETE CLASS $f'_{ci} = 6500\text{psi}$ [45MPa] *

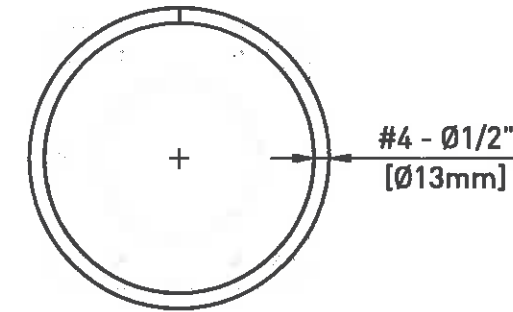

Tie the first 1-1/2 turns at the bearing plate side of the spiral to achieve full development

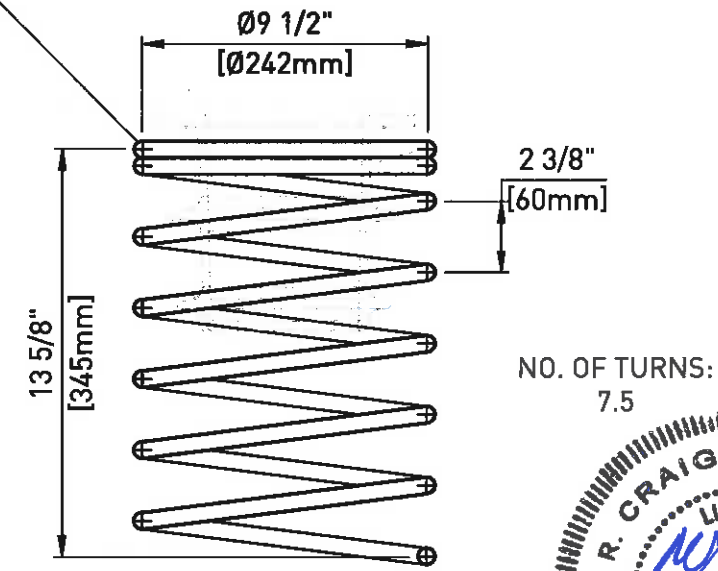
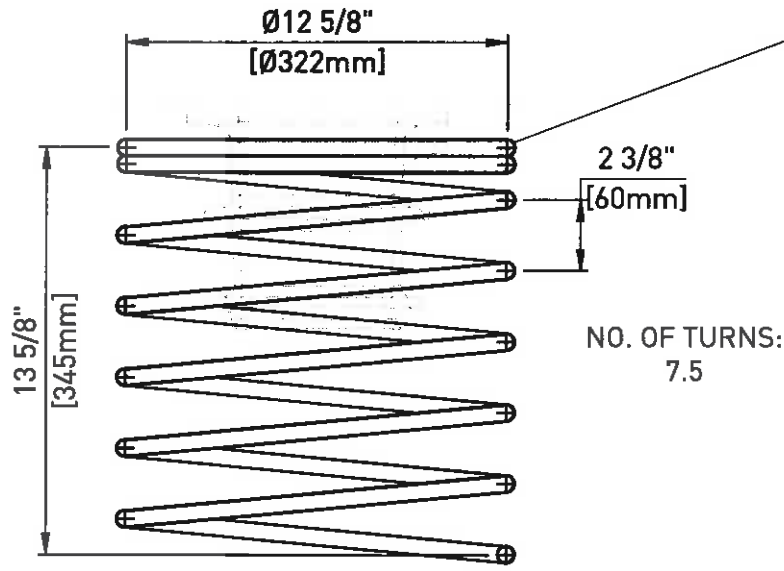

NO. OF TURNS:
7.5

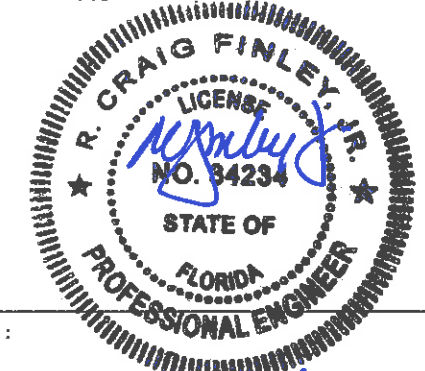

I have independently reviewed the calculations and testing reports, along with the documentation and certified that TENSA system spiral rebar detail meets the requirements as outlined in paragraph 3.3 PTI Anchorage Zone Design.

(*) Do not apply post-tensioning forces until the concrete mean compressive strength f'_{ci} is not less than the values shown in the present drawing.

NOTE: The local zone reinforcement is to be shown on the shop drawings.

Rev.	Date	Description	Drawn	Checked
0	12/20/17	First issue	F.M.	T.C.

Material : Steel Rebar GR60, #4 - according to ASTM A615		Treatment : -	
		Title : SPIRAL REBAR for 12AMTS15	
		Drawn : F.MORAGLIA	Checked : T.CICCONO
TENSA AMERICA LLC - www.tensaamerica.com - PHONE: +1 305-866-9917 1111 KANE CONCOURSE, 5. TE 200 - BAY HARBOR ISLAND - 33154 FL	Date : 12/20/2017	Dimensions : INCH [mm] mm FOR REFERENCE ONLY	Part # : 12-05-00
Document Property of TENSA AMERICA LLC This drawing contains proprietary information restricted solely for use on this project and may not be reproduced in whole or in part. For any other use without the expressed written permission of TENSA AMERICA LLC, the company will safeguard its rights according to the civil and penal provisions of the Law.			

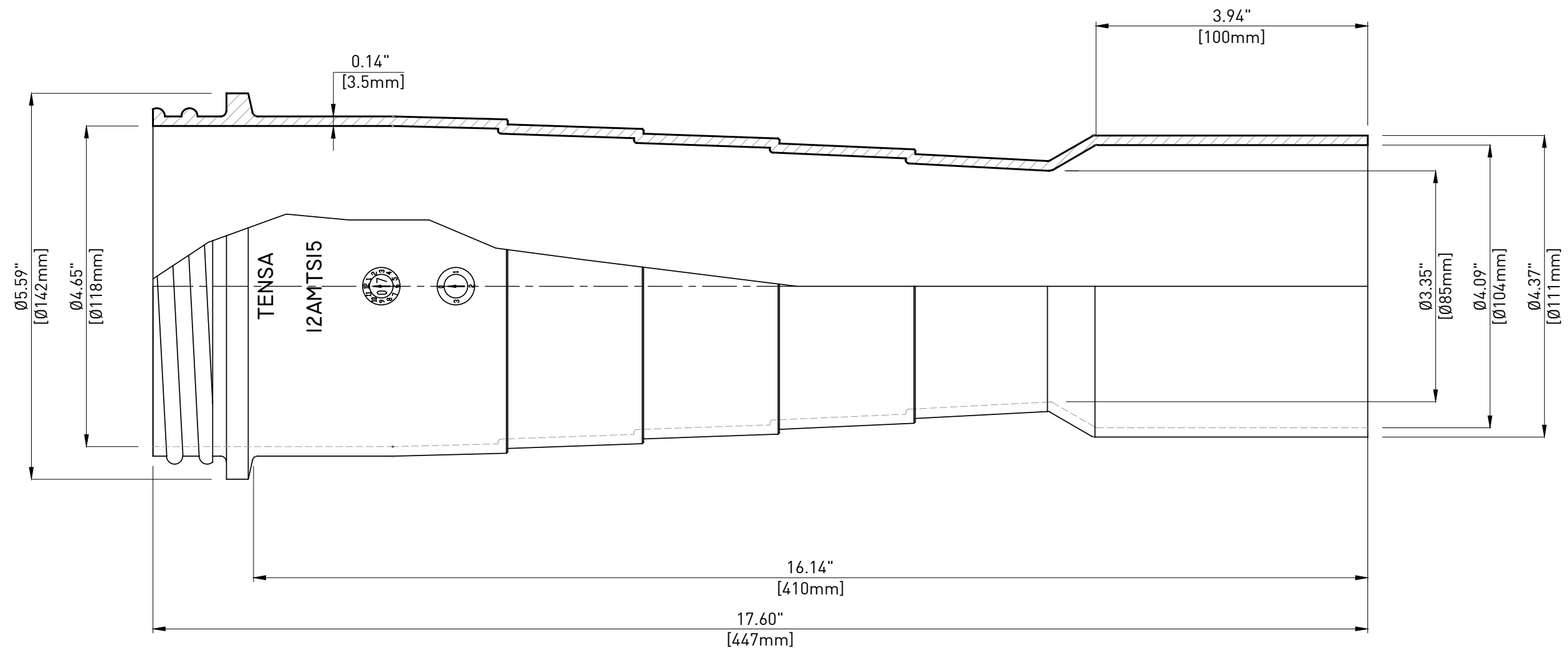

Marking — Type

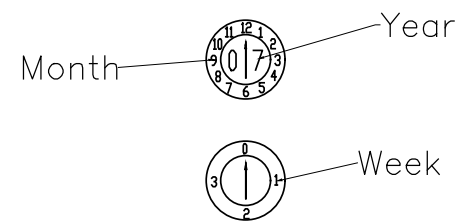

Material : High Density Polyethylene - according to ASTM D3350		Treatment : -	
		Title : TRUMPET for 12AMTS15 Internal Bonded and Internal Unbonded / External systems	
		Drawn : L.CIVATI	Checked : T.CICCONO
Date : 12/20/2016	Dimensions : INCH [mm] mm FOR REFERENCE ONLY	Part # : 12-06-00	Code : -

Rev.	Date	Description	Drawn	Checked
0	12/20/16	First issue	L.C.	T.C.

Document Property of TENZA AMERICA LLC
 This drawing contains proprietary information restricted solely for use on this project and may not be reproduced in whole or in part. For any other use without the expressed written permission of TENZA AMERICA LLC, the company will safeguard its rights according to the civil and penal provisions of the Law.

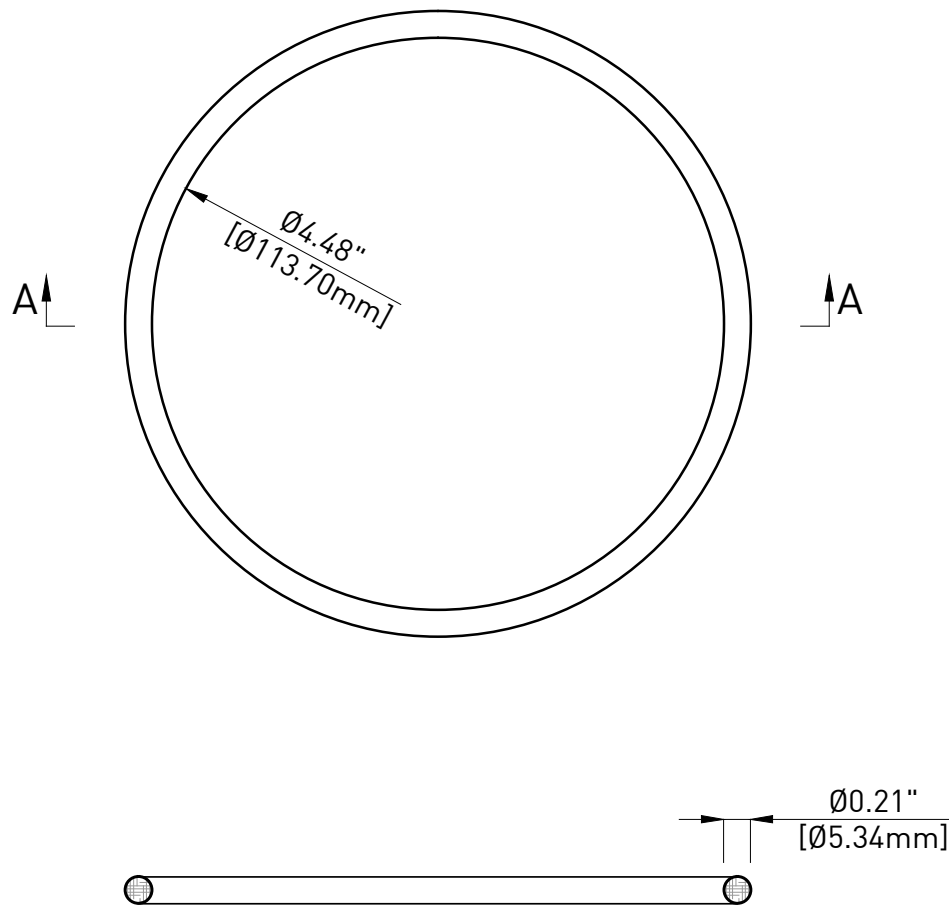

SECTION A-A

NOTE:

- This drawing is not intended for manufacturing purposes.

0	08/23/16	First issue	L.C.	T.C.
Rev.	Date	Description	Drawn	Checked
Material : NBR - according to FDOT Tab. 2.2.1.7-1 Sec.960		Treatment : -		
		Title : Centro Guarnizioni TIGER s.r.l COMPRESSION SEAL for 12AMTS15 between Anchor and Trumpet		
TENZA AMERICA LLC - www.tensaamerica.com - PHONE: +1 305-866-9917 1111 KANE CONCOURSE, S.TE 200 - BAY HARBOR ISLAND - 33154 FL		Drawn : L.CIVATI	Checked : T.CICCONE	
Date : 08/23/2016	Dimensions : <small>INCH [mm]</small> <small>mm FOR REFERENCE ONLY</small>	Part # : 12-06-01	Code : OR 06450	
<small>Document Property of TENZA AMERICA LLC</small> <small>This drawing contains proprietary information restricted solely for use on this project and may not be reproduced in whole or in part. For any other use without the expressed written permission of TENZA AMERICA LLC, the company will safeguard its rights according to the civil and penal provisions of the Law.</small>				

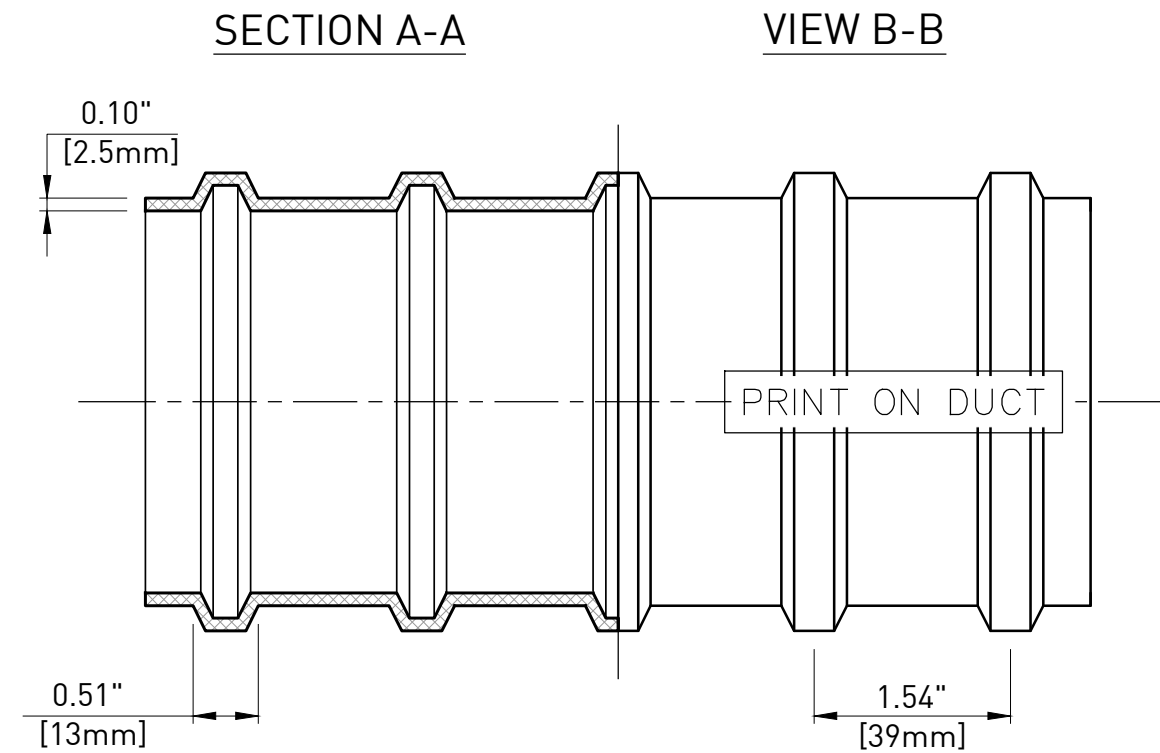
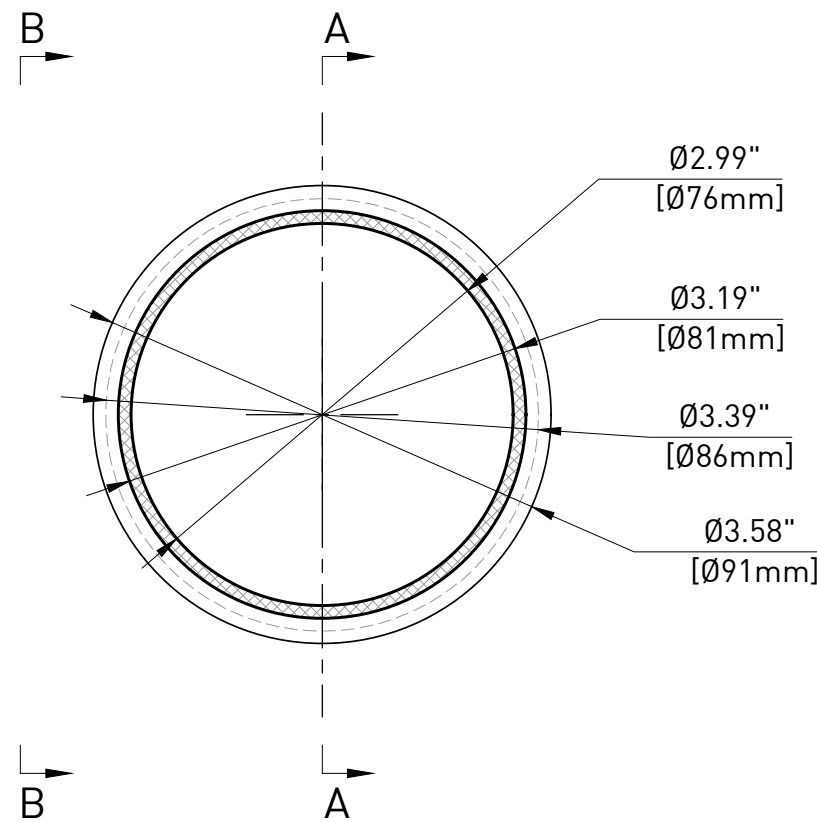

PRINT ON DUCT:
 "GTI GENERAL TECHNOLOGIES, INC. STAFFORD, TEXAS ___ U.S. & FOREIGN PATENTS P.N. 220300 76mm"

Minimum radii of curvature determined as per FIB Bulletin 75, Annex A8					
Strands Nr.	8	9	10	11	12
Minimum radius [ft (m)]	14.44 (4.40)	15.75 (4.80)	17.06 (5.20)	18.37 (5.60)	19.72 (6.01)

NOTE:

- All dimensions are measured;
- This drawing is not intended for manufacturing purposes;
- Duct is delivered in straight sections and is not intended to be coiled;
- Duct meets FDoT requirements in terms of Minimum Wall Thickness (Table 2.2.1.1-1 Section 960).

Rev.	Date	Description	Drawn	Checked
0	07/04/18	First issue	F.M.	T.C.

Material : Polypropylene - according to ASTM D4101		Treatment : -	
		Title : GTI DUCT 3.00" (76mm) for Internal Bonded System Standard fit for 12AMTS15	
		TENSA AMERICA LLC - www.tensaamerica.com - PHONE: +1 305-866-9917 1111 KANE CONCOURSE, S.TE 200 - BAY HARBOR ISLAND - 33154 FL	
Date : 07/04/2018	Dimensions : INCH [mm] mm FOR REFERENCE ONLY	Drawn : F.MORAGLIA	Checked : T.CICCONE
Date : 07/04/2018		Part # : I-12-07-00	Code : 220300
Document Property of TENSA AMERICA LLC This drawing contains proprietary information restricted solely for use on this project and may not be reproduced in whole or in part. For any other use without the expressed written permission of TENSA AMERICA LLC, the company will safeguard its rights according to the civil and penal provisions of the Law.			

SECTION/ELEVATION

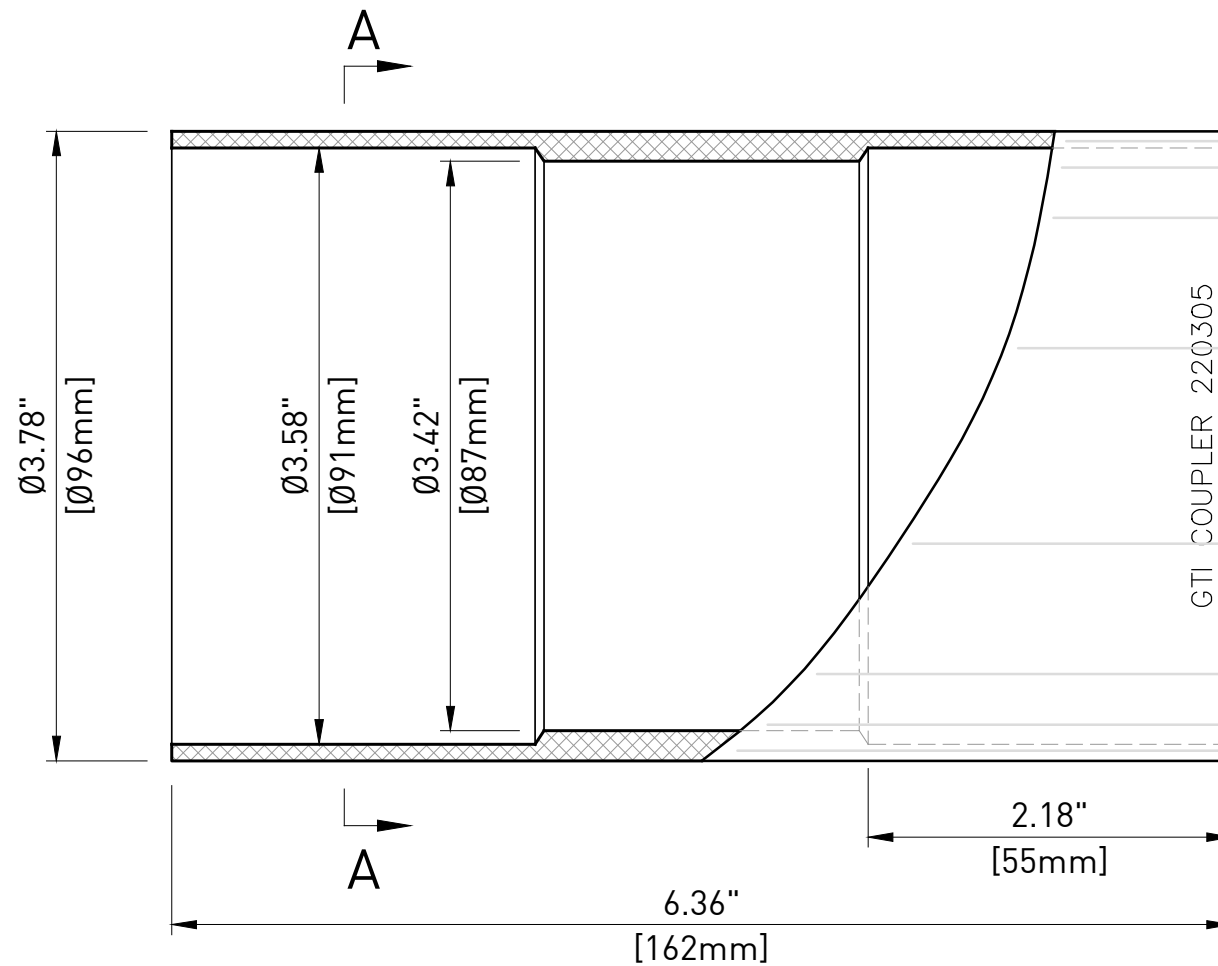

SECTION A-A



NOTE:

- This drawing is not intended for manufacturing purposes;
- Coupler meets or exceeds FDOT requirements (Section 960-2.2.1.5 and 2.4.4);
- Standard fit for 3.00" [76mm] corrugated plastic duct.

Rev.	Date	Description	Drawn	Checked
0	12/20/16	First issue	L.C.	T.C.

Material : Polypropylene - according to ASTM D4101		Treatment : -	
		Title : GTI SLIP-ON COUPLER for Internal Bonded System Standard fit for 12AMTS15	
		Drawn : L.CIVATI	Checked : T.CICCONE
TENSA AMERICA LLC - www.tensaamerica.com - PHONE: +1 305-866-9917 1111 KANE CONCOURSE, S. TE 200 - BAY HARBOR ISLAND - 33154 FL		Date : 12/20/2016	Part # : I-12-07-01
Date : 12/20/2016		Dimensions : INCH [mm] mm FOR REFERENCE ONLY	Code : 220305
Document Property of TENSA AMERICA LLC This drawing contains proprietary information restricted solely for use on this project and may not be reproduced in whole or in part. For any other use without the expressed written permission of TENSA AMERICA LLC, the company will safeguard its rights according to the civil and penal provisions of the Law.			

SECTION/ELEVATION

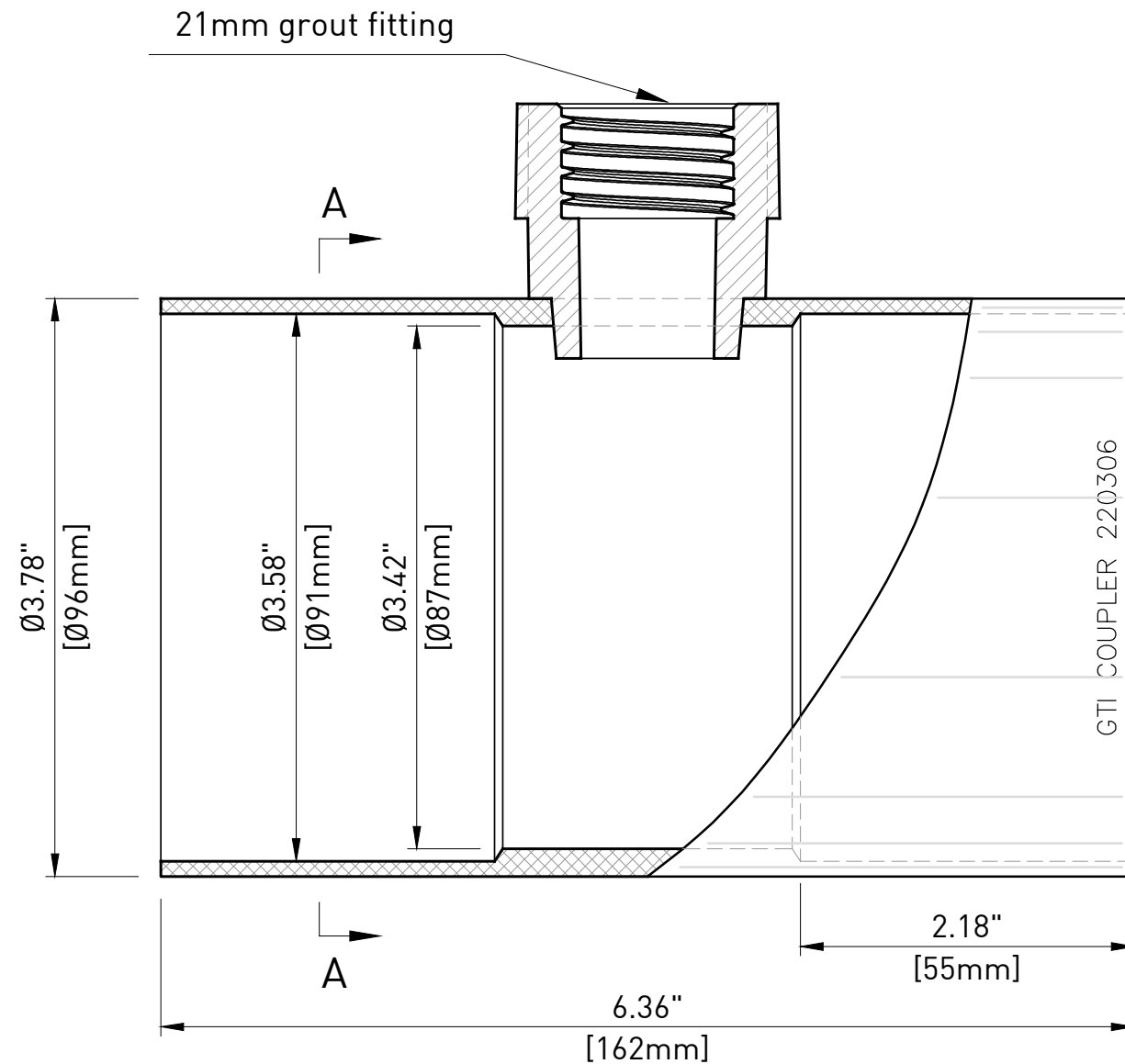

SECTION A-A

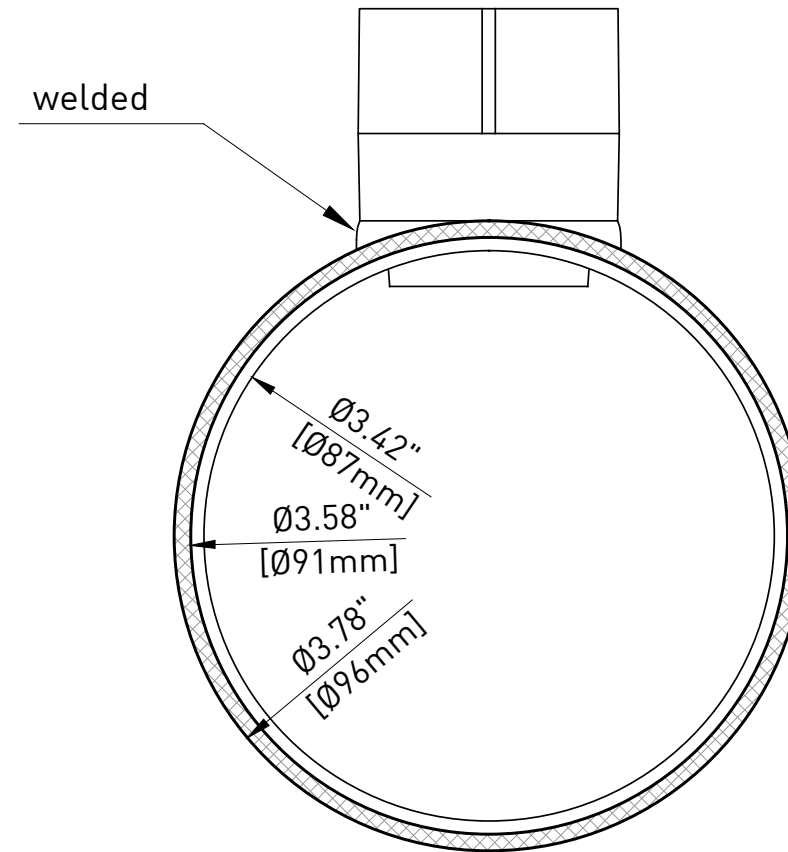

NOTE:

- This drawing is not intended for manufacturing purposes;
- Coupler meets or exceeds FDOT requirements (Section 960-2.2.1.5 and 2.4.4);
- Standard fit for 3.00" [76mm] corrugated plastic duct.

Material : Polypropylene - according to ASTM D4101	Treatment : -
---	------------------

	Title : GTI SLIP-ON COUPLER W/ 21mm PORT for Internal Bonded System Standard fit for 12AMTS15	
	Drawn : L.CIVATI	Checked : T.CICCONE

TENSA AMERICA LLC - www.tensaamerica.com - PHONE: +1 305-866-9917 1111 KANE CONCOURSE, S. TE 200 - BAY HARBOR ISLAND - 33154 FL		Date : 12/20/2016	Dimensions : ^{INCH [mm]} mm FOR REFERENCE ONLY	Part # : I-12-07-02	Code : 220306
--	--	-------------------	--	---------------------	---------------

Rev.	Date	Description	Drawn	Checked
0	12/20/16	First issue	L.C.	T.C.

Document Property of TENSA AMERICA LLC
This drawing contains proprietary information restricted solely for use on this project and may not be reproduced in whole or in part. For any other use without the expressed written permission of TENSA AMERICA LLC, the company will safeguard its rights according to the civil and penal provisions of the Law.

ELEVATION

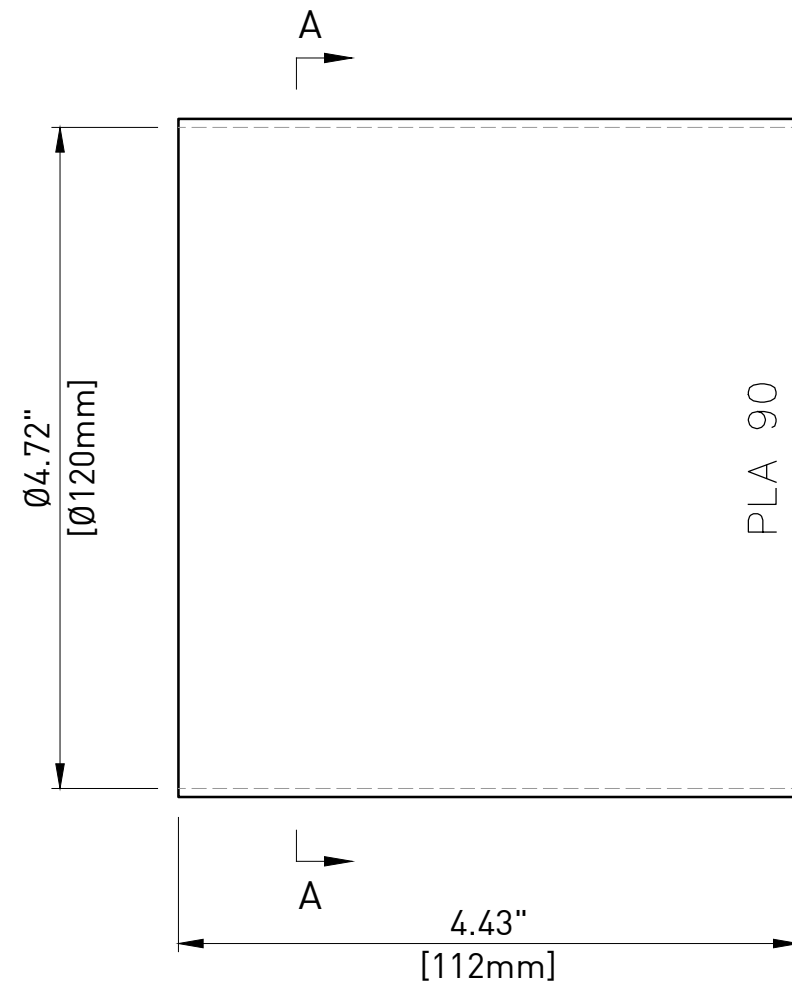

SECTION A-A

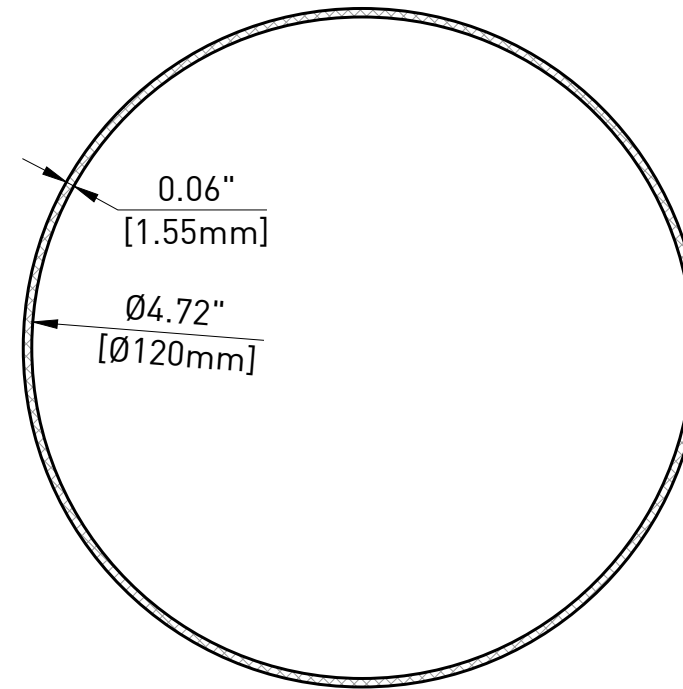

INSTALLATION

Surface Preparation

1. Lightly abrade the coupler (or trumpet) and duct to a distance of 2 inches (50mm) beyond each end of the shrinksleeve.
2. Wipe clean the coupler (or trumpet) and duct to remove foreign contaminants. Ensure that the components are dry before cleaning.

Installation

3. Completely remove the inner release liner from the sleeve and center the shrinksleeve over the joint to be sealed.
4. Using the appropriate sized heat gun or torch, begin at the center of the shrinksleeve and heat circumferentially around the duct and coupler. Use broad strokes.
5. Continue heating from the center toward one end of the shrinksleeve until recovery is complete (sleeve has shrunk). In a similar manner heat and shrink the remaining side. Shrinking has been completed when the adhesive begins to ooze at the shrinksleeve edges all around the circumference.
6. Finish shrinking the sleeve with long horizontal strokes over the entire surface to ensure a uniform bond.
7. Allow the shrinksleeve to cool for two hours prior to usage.

Inspection

8. Check the full contact of sleeve with the coupler (or trumpet) and duct.
9. Check that adhesive flows beyond both sleeve edges.
10. Check that no cracks or holes are present in shrinksleeve backing.

NOTE:

- The installation procedure is general; reference to manufacturer's instruction manual for the detailed installation instructions;
- This drawing is not intended for manufacturing purposes;
- Heat shrink sleeve meets or exceeds FDoT requirements (Table 2.2.1.8-1 Section 960);
- Tabular sleeve diameter:
 - 4.7" [120mm] as supplied
 - 3.3" [81mm] fully recovered

Rev.	Date	Description	Drawn	Checked
0	05/14/18	First issue	L.C.	T.C.

Material : Coated Polyolefin Backing - according to FDoT Tab.2.2.1.8-1 Sec.960		Treatment : -	
		Title : CANUSA-CPS HEAT SHRINK SLEEVE Standard fit for 12AMTS15	
		Drawn : L.CIVATI	Checked : T.CICCONE
Date : 05/14/2018	Dimensions : <small>INCH [mm]</small> <small>mm FOR REFERENCE ONLY</small>	Part # : 12-07-06	Code : PLA-90-112-BK
Document Property of TENSA AMERICA LLC This drawing contains proprietary information restricted solely for use on this project and may not be reproduced in whole or in part. For any other use without the expressed written permission of TENSA AMERICA LLC, the company will safeguard its rights according to the civil and penal provisions of the Law.			

SECTION/ELEVATION

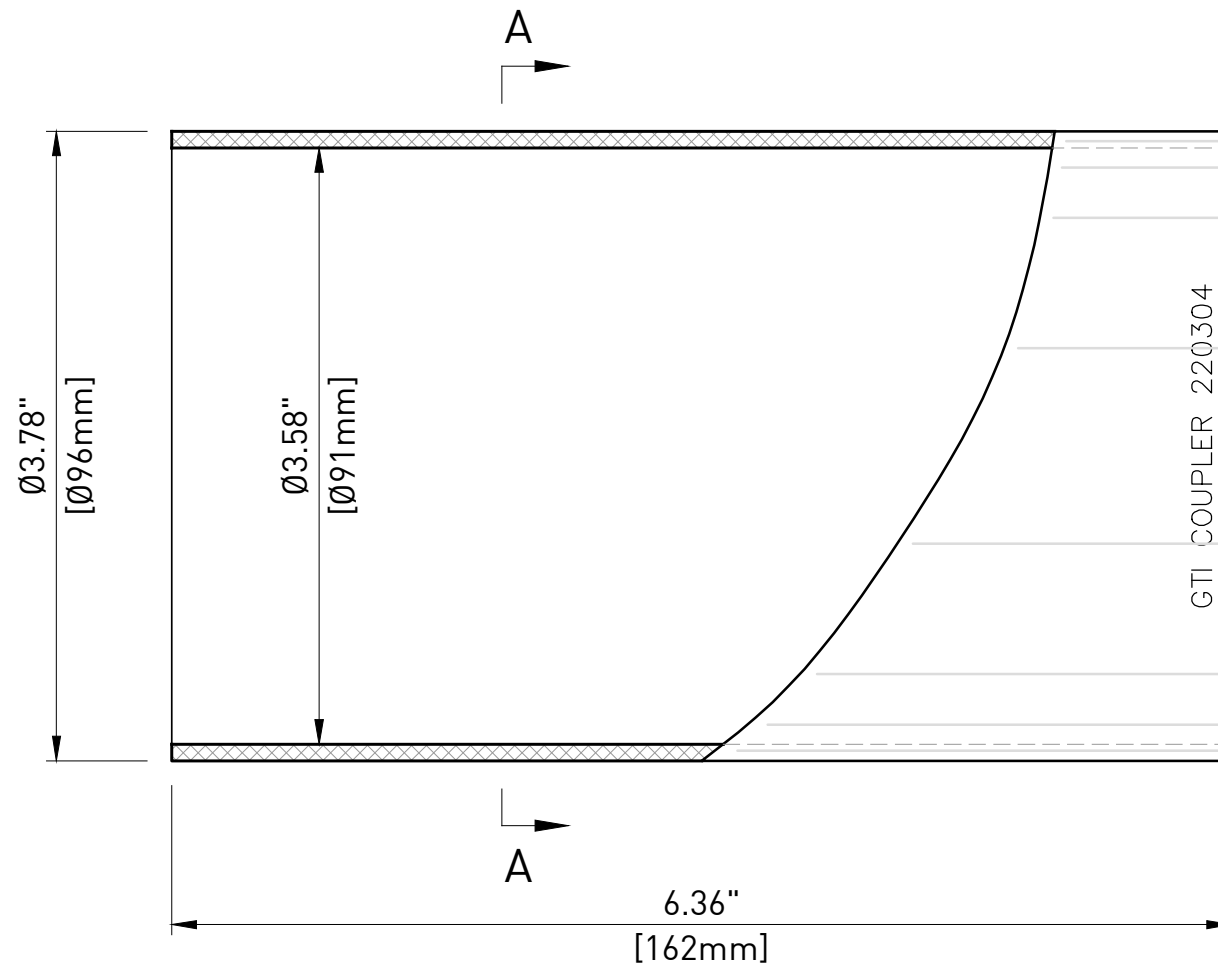

SECTION A-A

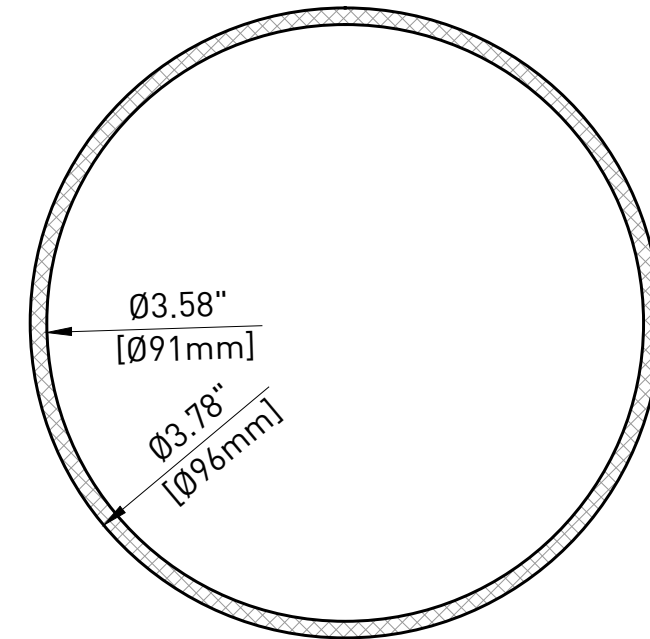

NOTE:

- This drawing is not intended for manufacturing purposes;
- Coupler meets or exceeds FDoT requirements (Section 960-2.2.1.5 and 2.4.4);
- Standard fit for 3.00" [76mm] corrugated plastic duct.

Rev.	Date	Description	Drawn	Checked
0	12/20/16	First issue	L.C.	T.C.

Material : Polypropylene - according to ASTM D4101	Treatment : -
---	------------------

	Title : GTI STEPLESS COUPLER Adaptation for 3.00" duct with 12AMTS15 trumpet	
	Drawn : L.CIVATI	Checked : T.CICCONE

TENSA AMERICA LLC - www.tensaamerica.com - PHONE: +1 305-866-9917 1111 KANE CONCOURSE, S. TE 200 - BAY HARBOR ISLAND - 33154 FL	Date : 12/20/2016	Dimensions : ^{INCH [mm]} mm FOR REFERENCE ONLY	Part # : 12-07-07	Code : 220304
--	-------------------	--	-------------------	---------------

Document Property of TENSA AMERICA LLC
This drawing contains proprietary information restricted solely for use on this project and may not be reproduced in whole or in part. For any other use without the expressed written permission of TENSA AMERICA LLC, the company will safeguard its rights according to the civil and penal provisions of the Law.