

**HDPE PIPE COUPLING**

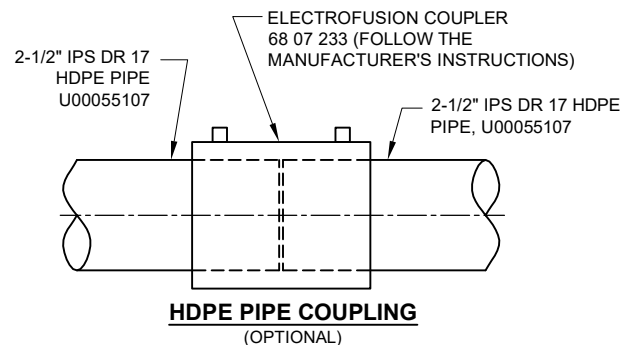

**HDPE PIPE COUPLING (OPTIONAL)**

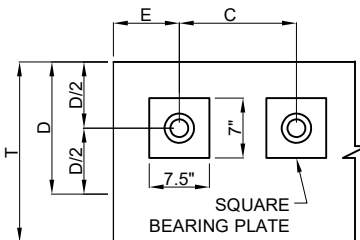

**SQUARE BEARING PLATE**

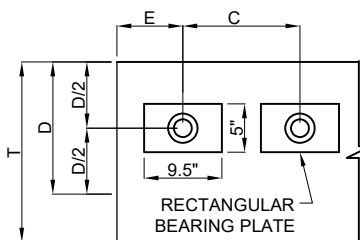

**RECTANGULAR BEARING PLATE**

LEGEND:  
E = END DISTANCE  
C = CENTER TO CENTER DISTANCE  
D/2 = EDGE DISTANCE

Plate Type	fci, ksi	Depth, D (in)	Minimum distances, in	
			End dist, E	c/c dist, C
Square	5.5	11.0	5.89	7.78
	5.0	12.0	6.41	8.83
	4.5	13.0	6.98	9.95
Rectangular	4.0	15.0	8.03	12.05
	5.0	9.0	8.55	13.10
	4.5	10.0	9.50	15.00
	4.0	12.0	11.40	18.80

Plate Type	Part No.	Width, in	Length, in	Thickness t, in
Square	B36E22700	7	7.5	1.75
Rectangular	B36E22800	5	9.5	2

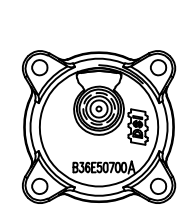

**CAP END VIEW**

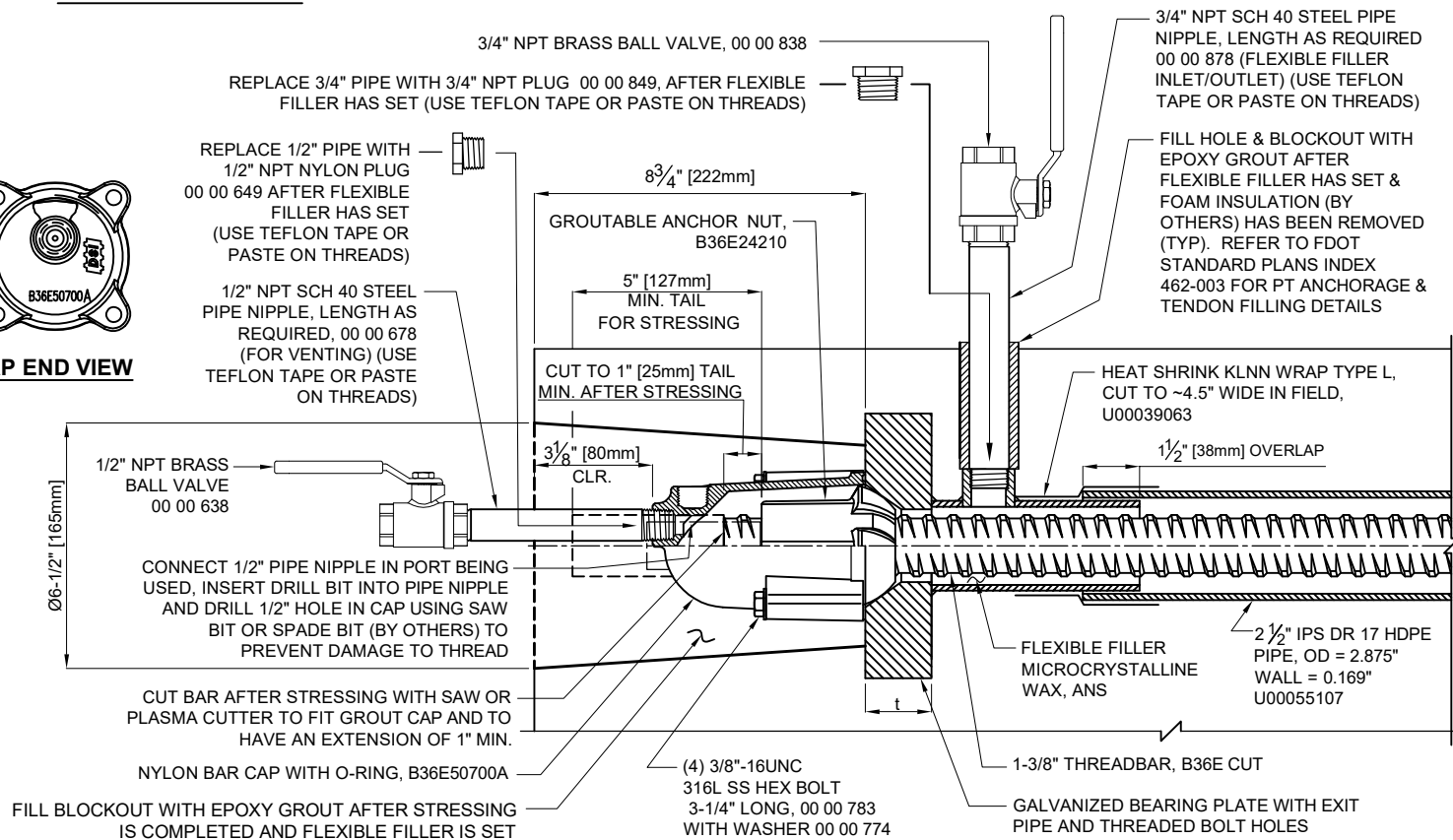

**BLOCKOUT DETAIL**

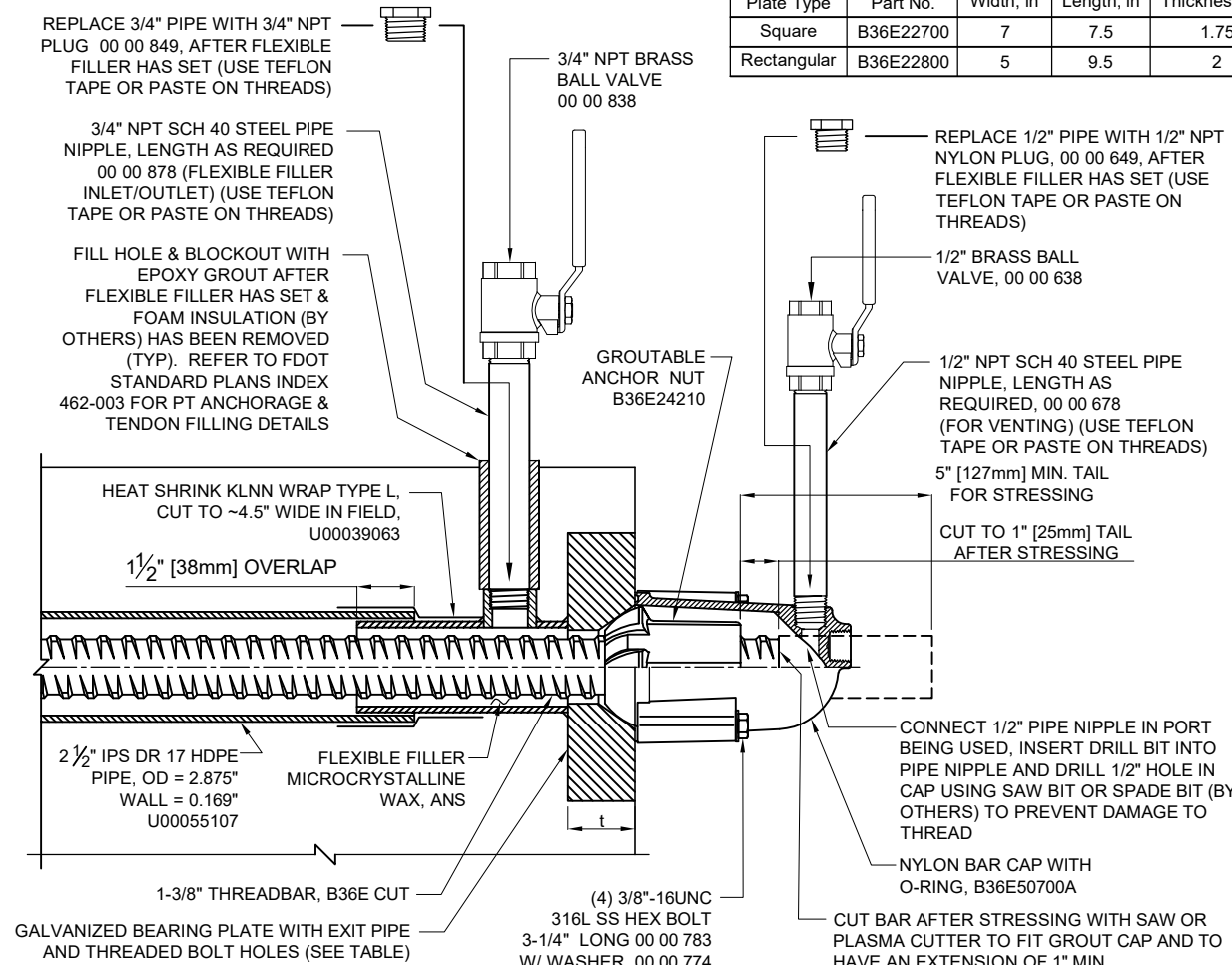

**SURFACE MOUNT DETAIL**

**WARNING:** READ AND COMPLY WITH ALL APPLICABLE SAFETY AND OPERATING INSTRUCTIONS AND WARNINGS FOR THREADBAR STRESSING BEFORE STARTING ANY WORK OR OPERATION.

**CAUTION:** WHEN PRESSURIZING GROUT CAPS, DO NOT STAND BEHIND CAPS!

**CAUTION** WHEN USING HIGH STRENGTH DYWIDAG THREADBAR® (GRADE 150) DO NOT WELD TO BAR. DO NOT USE BAR AS GROUND CONNECTION FOR WELDING. DO NOT ALLOW HOT SLAG OR SPARKS TO TOUCH BAR. DO NOT DAMAGE BAR SURFACE. DO NOT USE BARS WITH KINKS OR SHARP BENDS. FAILURE TO HEED THIS WARNING COULD CAUSE BAR TO BREAK RESULTING IN INJURY OR DAMAGE

- NOTES:
1. USERS SHALL REFER TO FDOT STANDARD SPECIFICATIONS AND PROJECT SPECIFIC CRITERIA FOR TENDON INSTALLATION, STRESSING, & FLEXIBLE FILLER.
  2. REQUIRED REINFORCING BARS ARE NOT SHOWN ON THIS DRAWING.
  3. MAXIMUM ANGULAR MISALIGNMENT WHEN USING ANCHOR NUT: ±2°.
  4. CENTER TO CENTER, END AND EDGE DISTANCE DEPENDS ON THE LOCATION OF THE BAR AND CONCRETE STRENGTH, (SEE TABLE).
  5. C/C DISTANCE = 2 X END DISTANCE - 2 X CONCRETE COVER (2" ASSUMED). TIGHTER C/C DISTANCE SHOULD BE EVALUATED.
  6. BURSTING REINFORCEMENT IS NOT SHOWN AND WILL BE INCLUDED WITH THE SHOP DRAWINGS.
  7. THREADBAR TENDONS ARE STRESSED FROM ONE END ONLY.

MATERIAL LIST		
PART NO.	DESCRIPTION	MATERIAL SPECIFICATION
B36E CUT	1-3/8" THREADBAR	ASTM A722 TYPE II STEEL
B36E22700 OR B36E22800	7"x75"x1.75" SQ. OR 5"x9.5"x2" RECT. BEAR. PLATE W/EXIT PIPE 2" SCH 40 STEEL PIPE 5-1/2" LONG & BOLT HOLES, GALV.	STEEL PLATE, ASTM A36, PIPE, ASTM A53 GALVANIZED
B36E24210	1-3/8" GROUTABLE ANCHOR NUT	FORGING, NORMALIZED C1045
B36E50700A	NYLON BAR CAP WITH O-RING FOR FLEXIBLE FILLER	CAP: NYLON 6, 20% GLASS FIBER FILLED O-RING: HNBR
00 00 783 00 00 774	3/8"-16UNC HEX BOLT, 3 1/4" LONG NARROW WASHER	316L STAINLESS STEEL
U00055107	2 1/2" IPS DR 17 HDPE PIPE	HDPE
U00039063	HEAT SHRINK KLNN WRAP, TYPE L, 18" WIDE CUT TO ~4.5" WIDE IN FIELD	ACCORD. TO FDOT SPEC. P.T. SEC. 960-2.2.1.8

MATERIAL LIST		
PART NO.	DESCRIPTION	MATERIAL SPECIFICATION
00 00 878	3/4" NPT PIPE NIPPLE, LENGTH AS REQ'D (TEMP.)	SCH 40, BLACK WELDED STEEL
00 00 838	3/4" NPT VALVE (TEMPORARY)	BRASS
00 00 849	3/4" NPT PLUG	NYLON 6, WHITE
00 00 678	1/2" NPT PIPE NIPPLE, LENGTH AS REQ'D (TEMP.)	SCH 40, BLACK WELDED STEEL
00 00 638	1/2" NPT VALVE (TEMPORARY)	BRASS
00 00 649	1/2" NPT PLUG	NYLON 6, WHITE
ANS	FLEXIBLE FILLER MICROCRYSTALLINE WAX	ACCORD. TO FDOT SPECS. 938-5
ANS	TEFLON TAPE OR PASTE FOR THREADS	--
68 07 233	ELECTROFUSION COUPLER (OPTIONAL)	COMPOSITE

**DIMENSIONS: INCH [mm] mm FOR REFERENCE ONLY**

**INTERNAL FLEXIBLE FILLER 1-3/8" (36mm) THREADBAR ASSEMBLY DRAWING**

DATE: 06/29/20 DWG: I. Tira/G. Malecki CHK: SI APP: SI

THIS DRAWING, THE PERTINENT ENCLOSURES, DESCRIPTIONS, CALCULATIONS ETC. AND THEIR CONTENTS ARE THE PROPERTY OF DYWIDAG SYSTEMS INTERNATIONAL, USA, INC. THEY ARE NOT ALLOWED TO BE DUPLICATED WITHOUT OUR PERMISSION. THEY ARE ALSO NOT TO BE SHOWN OR EXPLAINED FOR ANY REASON TO A THIRD PARTY OTHER THAN FOR REASONS EXPRESSLY INTENDED BY DSI'S SUBMITTAL TO THE ORIGINAL RECEIVER. THEY HAVE TO BE RETURNED UPON REQUEST.

REV.	DATE	NAME	

WEIGHT

SCALE 1:5

DRAWING NUMBER: PT 36E 100

**DYWIDAG-SYSTEMS INTERNATIONAL, USA, INC.**  
POST TENSIONING / REINFORCING UNIT PHONE: 630-739-1100 **DYWIDAG**  
320 MARMON DRIVE - BOLINGBROOK, IL FAX: 630-739-1405

RIGHT HAND THREAD

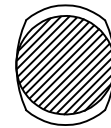
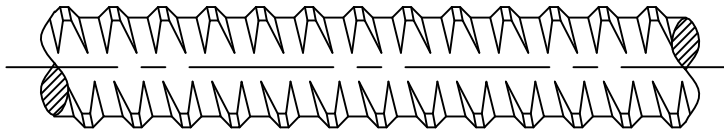

	<u>PART NUMBERS</u>	<u>SPECIFICATIONS</u>
FOR BARE BAR:	B36E CUT	ASTM A722 TYPE II

<u>PHYSICAL PROPERTIES</u>	
EFFECTIVE AREA:	1.58 SQ.IN. (1019 SQ.mm)
ULTIMATE STRENGTH:	150 KSI (1034 N/SQ.mm)
ULTIMATE LOAD:	237 KIPS (1054 KN)
YIELD LOAD:	191.2 KIPS (851 KN)
WEIGHT:	5.56 LBS./FT. (8.27 Kg/m)
MAX. BAR $\phi$ INCL. RIBS:	1.63 IN. (41.4mm)
AVERAGE CORE $\phi$ :	1.40 IN. (35.6mm)
PITCH:	0.709 IN. (18.0mm)

DIMENSIONS: INCH (mm) mm FOR REFERENCE ONLY		QUALITY PLAN NUMBER: QB00000050B		REV.				DATE	NAME	ECRN	PART NUMBER: B36E CUT
<b>1-3/8"Ø THREADBAR GRADE 150 KSI</b>				MATERIAL: SEE ABOVE		SCALE NTS					DRAWING NUMBER: B36E CUT
DATE: 12-23-91	DWG: G. MALECKI	CHK: H.K.	APP: K.S.								
THIS DRAWING, THE PERTINENT ENCLOSURES, DESCRIPTIONS, CALCULATIONS ETC. AND THEIR CONTENTS ARE THE PROPERTY OF DYWIDAG SYSTEMS INTERNATIONAL, USA, INC. THEY ARE NOT ALLOWED TO BE DUPLICATED WITHOUT OUR PERMISSION. THEY ARE ALSO NOT TO BE SHOWN OR EXPLAINED FOR ANY REASON TO A THIRD PARTY OTHER THAN FOR REASONS EXPRESSLY INTENDED BY DSI'S SUBMITTAL TO THE ORIGINAL RECEIVER. THEY HAVE TO BE RETURNED UPON REQUEST.				DYWIDAG-SYSTEMS INTERNATIONAL, USA, INC. 320 MARMON DRIVE - BOLINGBROOK, IL 60440 PHONE: 630-739-1100				FAX: 630-739-1405			



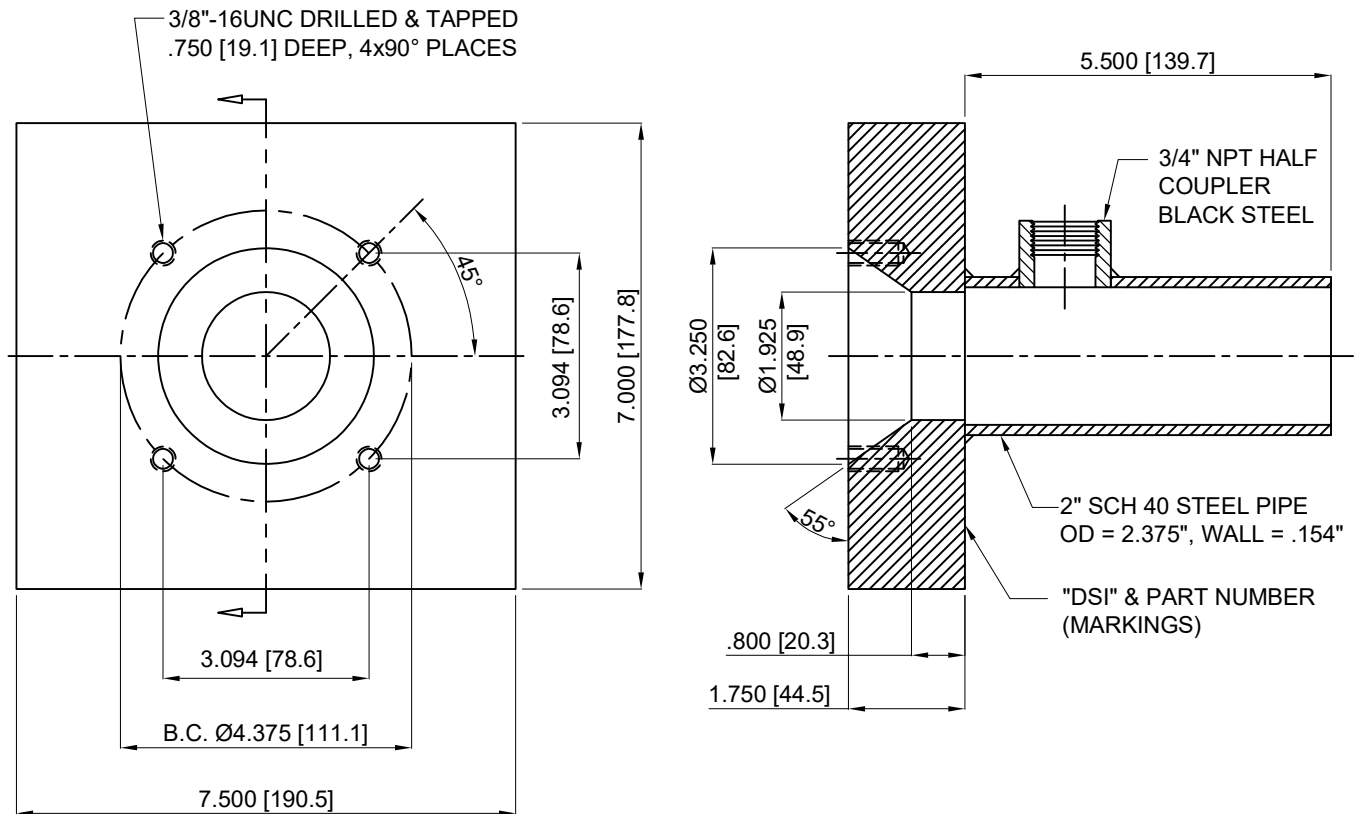

**NOTES:**

1. PLATE & PIPE GALVANIZED ACCORDING TO ASTM A123 AFTER WELDING.
2. DIMENSIONS AND TOLERANCES APPLY TO UNCOATED PLATES.
3. ENSURE THREADABILITY OF TAPPED HOLES IN COATED PLATES.
4. 2 1/2" IPS DR 17 HDPE PIPE U00055107 FITS OVER STEEL PIPE.

DIMENSIONS: INCH [mm] mm FOR REFERENCE ONLY		QUALITY PLAN NUMBER:		TOLERANCES: ±.020 UNLESS NOTED	WEIGHT ~25.8 LBS.	REV.	DATE	DWG.	CHK.	PART NUMBER <b>B36E22700</b>
SQUARE BEARING PLATE WITH EXIT PIPE FOR 1-3/8" THREADBAR TO BE USED WITH HDPE PIPE				PLATE MATERIAL: SEE MAT'L SPEC. PME0021100P	SCALE 1 : 3					DRAWING NUMBER: <b>B36E22700</b>
				PIPE MATERIAL: ASTM A53						
DATE: 12/13/18	DWG: I. TIRA / G.M.	CHK: SY	APP: SE							

THIS DRAWING, THE PERTINENT ENCLOSURES, DESCRIPTIONS, CALCULATIONS ETC. AND THEIR CONTENTS ARE THE PROPERTY OF **DYWIDAG SYSTEMS INTERNATIONAL, USA, INC.** THEY ARE NOT ALLOWED TO BE DUPLICATED WITHOUT OUR PERMISSION. THEY ARE ALSO NOT TO BE SHOWN OR EXPLAINED FOR ANY REASON TO A THIRD PARTY OTHER THAN FOR REASONS EXPRESSLY INTENDED BY **DSI's** SUBMITTAL TO THE ORIGINAL RECEIVER. THEY HAVE TO BE RETURNED UPON REQUEST.

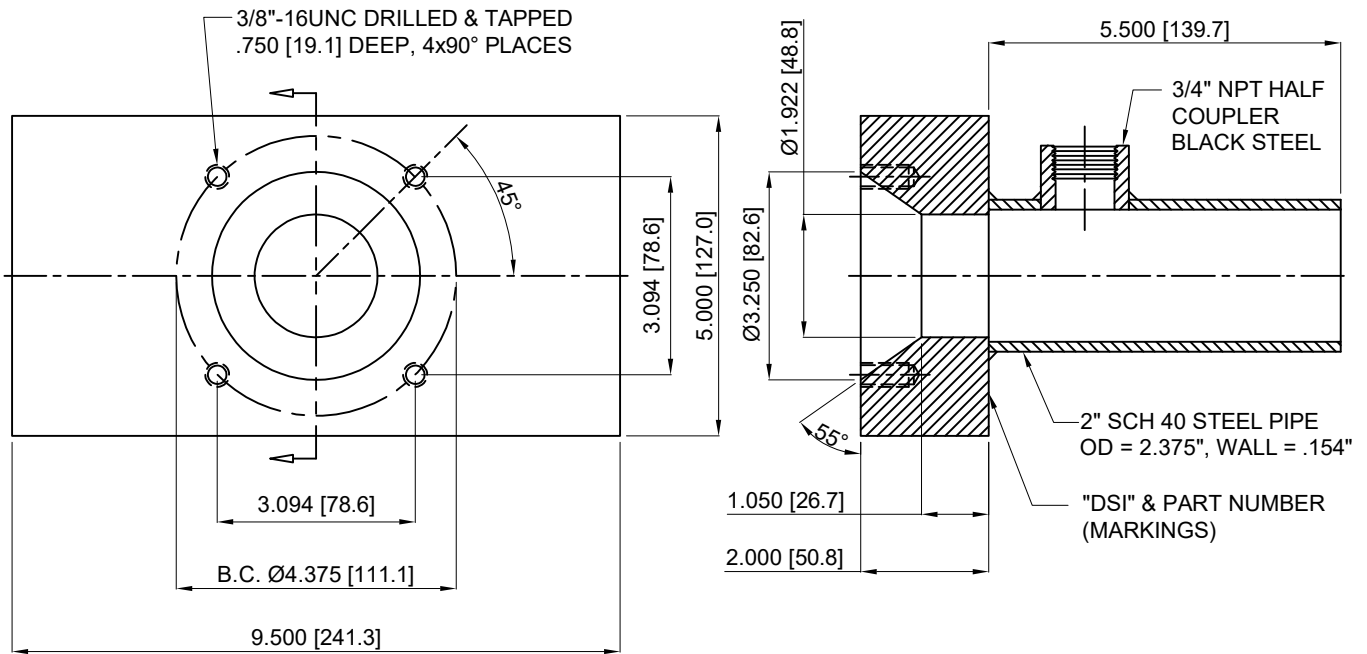

**NOTES:**

1. PLATE & PIPE GALVANIZED ACCORDING TO ASTM A123 AFTER WELDING.
2. DIMENSIONS AND TOLERANCES APPLY TO UNCOATED PLATES.
3. ENSURE THREADABILITY OF TAPPED HOLES IN COATED PLATES.
4. 2 1/2" IPS DR 17 HDPE PIPE U00055107 FITS OVER STEEL PIPE

DIMENSIONS: INCH [mm] mm FOR REFERENCE ONLY		QUALITY PLAN NUMBER:		TOLERANCES: ±.020 UNLESS NOTED	WEIGHT ~26.4 LBS.	REV.	DATE	DWG.	CHK.	PART NUMBER
RECT. BEARING PLATE WITH EXIT PIPE FOR 1-3/8" THREADBAR TO BE USED WITH HDPE PIPE				PLATE MATERIAL: SEE MAT'L SPEC. PME0021100P	SCALE 1:3					B36E22800
DATE: 12/13/18	DWG: I. TIRA / G.M.	CHK: SY	APP: SE	PIPE MATERIAL: ASTM A53						DRAWING NUMBER: B36E22800
THIS DRAWING, THE PERTINENT ENCLOSURES, DESCRIPTIONS, CALCULATIONS ETC. AND THEIR CONTENTS ARE THE PROPERTY OF DYWIDAG SYSTEMS INTERNATIONAL, USA, INC. THEY ARE NOT ALLOWED TO BE DUPLICATED WITHOUT OUR PERMISSION. THEY ARE ALSO NOT TO BE SHOWN OR EXPLAINED FOR ANY REASON TO A THIRD PARTY OTHER THAN FOR REASONS EXPRESSLY INTENDED BY DSI'S SUBMITTAL TO THE ORIGINAL RECEIVER. THEY HAVE TO BE RETURNED UPON REQUEST.				<b>DYWIDAG-SYSTEMS INTERNATIONAL, USA, INC.</b> POST TENSIONING / REINFORCING UNIT PHONE: 630-739-1100 <b>DYWIDAG</b> 320 MARMON DRIVE - BOLINGBROOK, IL FAX: 630-739-1405						

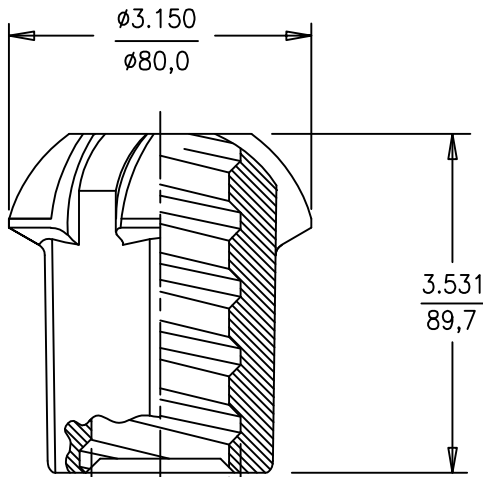
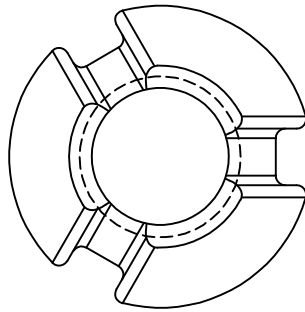

THREAD ACCORDING TO TOLERANCE DRAWING 8341/722  
 MINOR DIAMETER: 1.429 - 1.433 (36.30 - 36.40)  
 MINOR DIA.

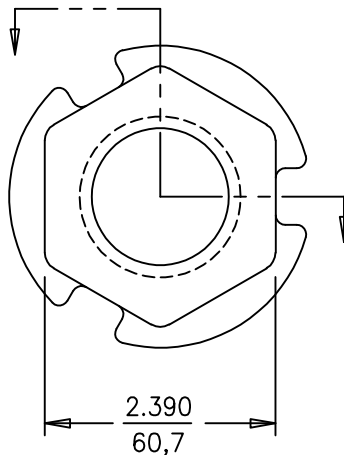

DIMENSIONS: INCH/mm mm FOR REFERENCE ONLY		QUALITY PLAN NUMBER: QBE0020100F		TOLERANCES: ±.035 UNLESS NOTED	WEIGHT 3.2 LBS.	REV.	DATE	NAME	PART NUMBER: <b>B36E24210</b>	
<b>1-3/8" GROUTABLE ANCHOR NUTS FOR THREADBAR GR. 150</b>				MATERIAL: C1045 FORGING ASTM A521-CF MOD. NORMALIZED BHN = 180-220	SCALE 1:2				DRAWING NUMBER: <b>B36E24200</b>	
				DATE: 06-07-05	DWG: G. MALECKI	CHK: H.K.	APP: K.S.			
THIS DRAWING, THE PERTINENT ENCLOSURES, DESCRIPTIONS, CALCULATIONS ETC. AND THEIR CONTENTS ARE THE PROPERTY OF DYWIDAG SYSTEMS INTERNATIONAL, USA, INC. THEY ARE NOT ALLOWED TO BE DUPLICATED WITHOUT OUR PERMISSION. THEY ARE ALSO NOT TO BE SHOWN OR EXPLAINED FOR ANY REASON TO A THIRD PARTY OTHER THAN FOR REASONS EXPRESSLY INTENDED BY DSI'S SUBMITTAL TO THE ORIGINAL RECEIVER. THEY HAVE TO BE RETURNED UPON REQUEST.				DYWIDAG-SYSTEMS INTERNATIONAL, USA, INC. 320 MARMON DRIVE - BOLINGBROOK, IL 60440 PHONE: 630-739-1100			FAX: 630-739-1405			<b>DYWIDAG</b>

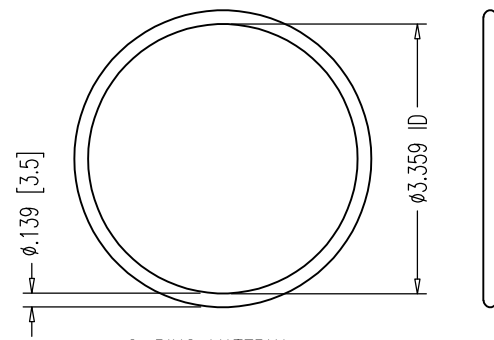
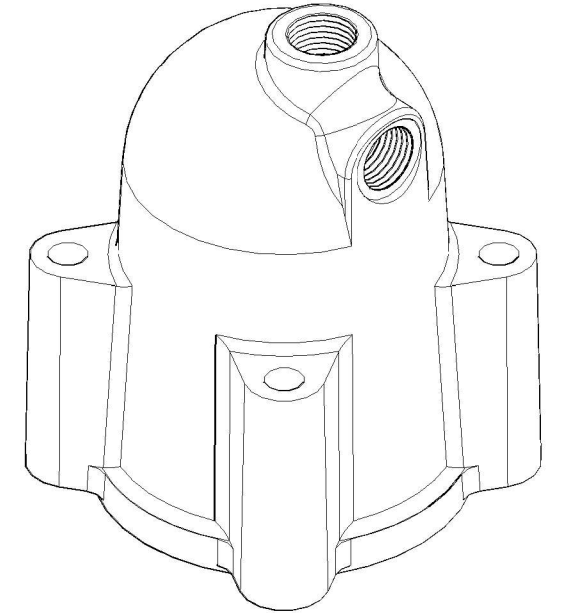
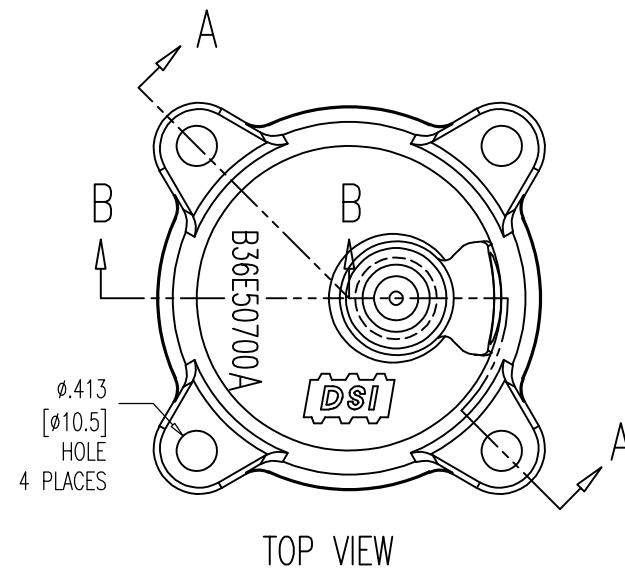
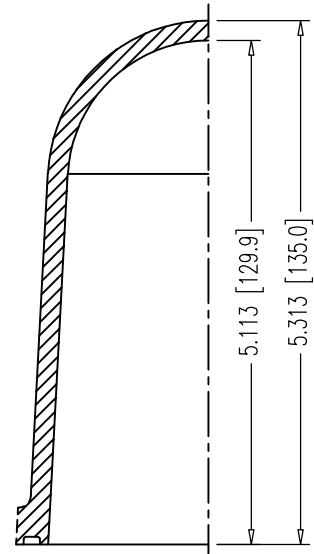
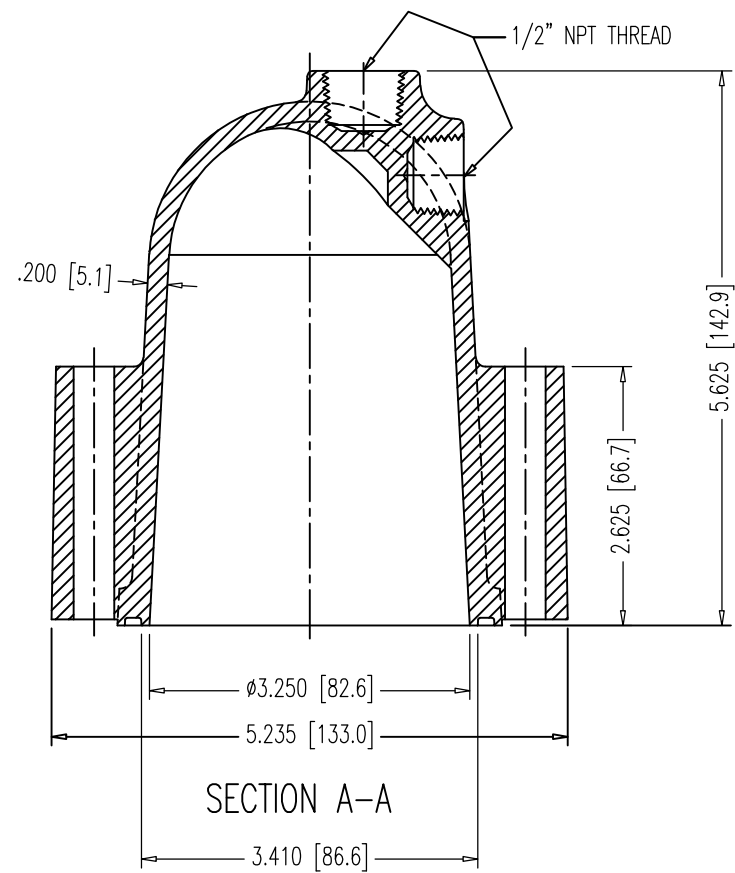

O-RING MATERIAL:  
 HNBR MEETING FDOT  
 SPECIFICATIONS 960-2.2.1.7.  
 #237 O-RING  
 3-3/8" x 3-5/8" x 1/8"  
 SCALE: NTS

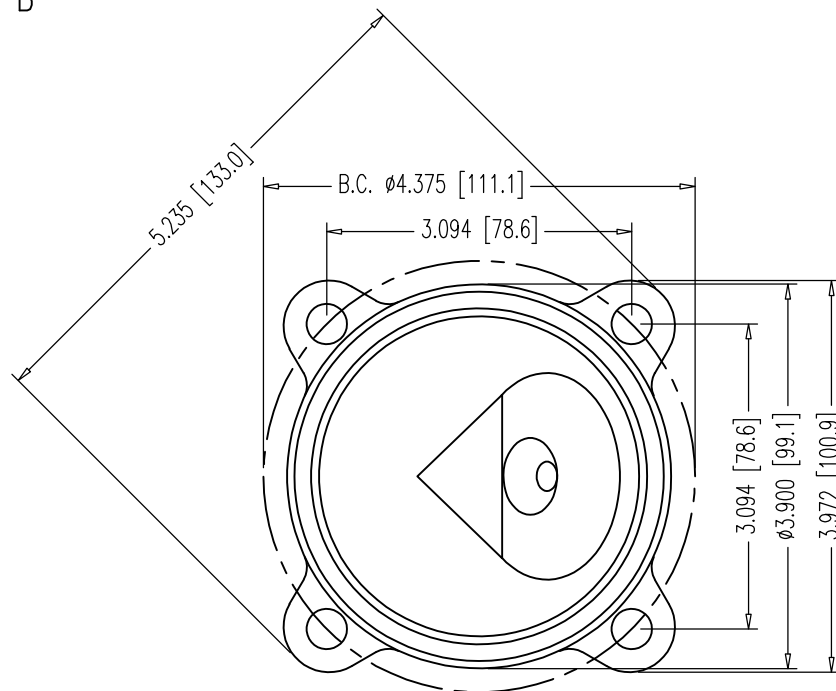

BOTTOM VIEW

NOTES:

- USE 3/8"-16UNC 316L S.S. HEX BOLTS, 3-1/4" LONG 00 00 783 W/SMALL DIA. WASHER 00 00 774.
- INSTALL O-RING IN GROOVE USING DROPS OF LIQUID ADHESIVE BEFORE SHIPPING.
- THE NYLON CONFORMS TO ASTM D5989 WITH CELL CLASSIFICATION S-PA0401 (ULTIMATE STRENGTH 10,000 PSI MIN., WITH UV STABILIZER ADDED).
- DRILL 1/2" [12.7] HOLE IN PORT BEING USED-CAUTION-RECOMMEND USING HOLE SAW BIT OR SPADE BIT (BY OTHERS), BE CAREFULL TO PREVENT DAMAGE TO THREADS OR CAP.
- WHEN PRESSURIZING GROUT CAPS, DO NOT STAND BEHIND CAPS!

DIMENSIONS: INCH [mm] mm FOR REFERENCE ONLY		QUALITY PLAN NUMBER: QS60072300P		TOLERANCES: SEE TOLERANCE NOTE	WEIGHT 0.817 LBS.	REV. 1	DATE 03/29/19	NAME S.I.	PART NUMBER: <b>B36E50700A</b>
<b>NYLON BAR GROUT CAP W/ O-RING FOR ALL 1" &amp; 1-1/4" NUTS &amp; 1-3/8" ANCHOR NUT FOR FLEXIBLE FILLER</b>				MATERIAL: NYLON 6 20% GLASS FIBER FILLED COLOR: BLACK	SCALE 1:2 UNLESS NOTED				DRAWING NUMBER: <b>B36E50700A</b>
DATE: 10-02-06	DWG: G. MALECKI	CHK: E.A.	APP: K.S.						

THIS DRAWING, THE PERTINENT ENCLOSURES, DESCRIPTIONS, CALCULATIONS ETC. AND THEIR CONTENTS ARE THE PROPERTY OF DYWIDAG SYSTEMS INTERNATIONAL, USA, INC. THEY ARE NOT ALLOWED TO BE DUPLICATED WITHOUT OUR PERMISSION. THEY ARE ALSO NOT TO BE SHOWN OR EXPLAINED FOR ANY REASON TO A THIRD PARTY OTHER THAN FOR REASONS EXPRESSLY INTENDED BY DSI'S SUBMITTAL TO THE ORIGINAL RECEIVER. THEY HAVE TO BE RETURNED UPON REQUEST.

DYWIDAG-SYSTEMS INTERNATIONAL, USA, INC.  
 320 MARMON DRIVE - BOLINGBROOK, IL 60440  
 PHONE: 630-739-1100 FAX: 630-739-1405





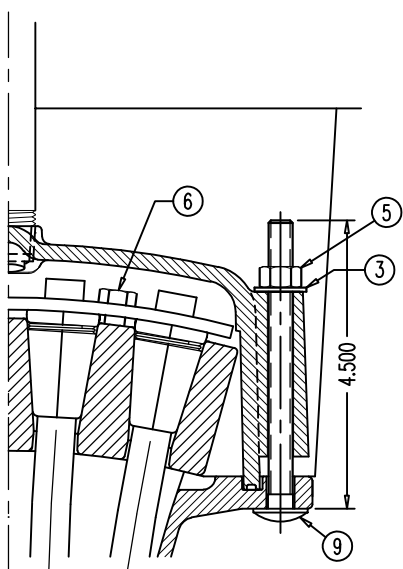

KEEPER PLATE 68 04 2637 ON  
WEDGE PLATE 68 04 2534A &  
NYLON CAP 68 04 2539 ON  
FLAT ANCHOR 68 04 2548

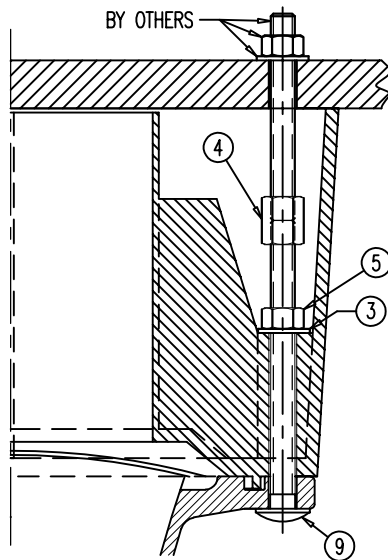

POCKET FORMER 68 04 2640  
ON FLAT ANCHOR 68 04 2548

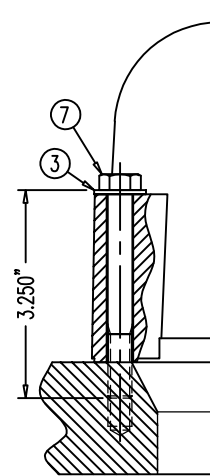

NYLON BAR CAP B36E50700 OR 50700A  
ON GALV. BEARING PLATE  
B26E22510, 22610, 22700, 22800,  
B32E22510, 22610, 22700, 22800,  
B36E22410, 22420, 22910, 22510,  
22610, 22700, 22800 & NYLON  
BAR CAP B66E50700 OR 50700A  
ON GALV. BEARING PLATE B66E22700

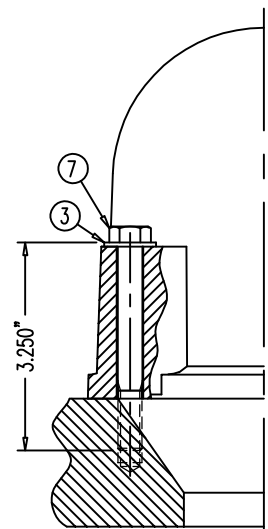

NYLON BAR CAP  
B46M50700  
OR 50700A  
ON GALV.  
BEARING PLATE  
B46E22700 &  
B46E22800

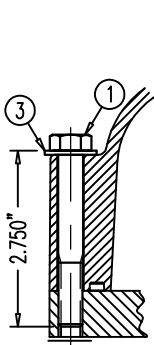

NYLON CAP  
68 07 7230 OR 7230A  
ON MPA 68 07 248

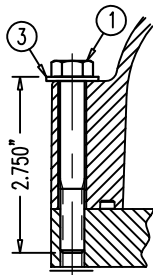

NYLON CAP  
68 12 7230 OR 7230A  
ON MPA 68 12 248

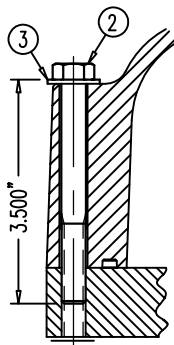

NYLON CAP  
68 19 7230 OR 7230A  
ON MPA 68 19 248

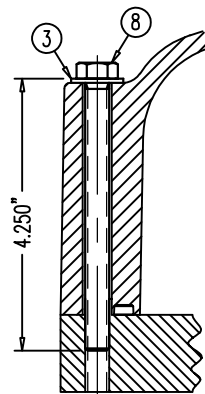

NYLON CAP  
68 27 7230 OR 7230A  
ON MPA 68 27 248

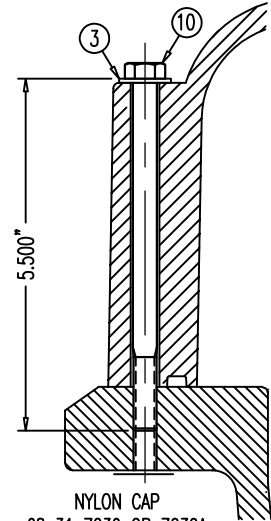

NYLON CAP  
68 31 7230 OR 7230A  
ON MPA 68 31 248

Ø.812



TYPE A NARROW WASHER  
FOR 3/8"-UNC BOLT

NOTE:  
THE 316L S.S. BOLTS ARE SPECIAL ORDER.  
ALL WASHERS, HEX NUTS & COUPLERS HAVE  
NO MARKINGS.

POS.	PART NUMBER	DISCRIPTION (ALL PARTS 316L STAINLESS STEEL UNLESS NOTED)
①	00 00 771	3/8"-16UNC HEX BOLT, 2-3/4" LONG (1" LONG THREAD)
②	00 00 772	3/8"-16UNC HEX BOLT, 3-1/2" LONG (1" LONG THREAD)
③	00 00 774	TYPE A NARROW WASHER FOR 3/8"-UNC BOLT
④	00 00 776	3/8"-16UNC COUPLER, ZINC COATED
⑤	00 00 777	3/8"-16UNC HEX NUT
⑥	00 00 778	5/16"-18UNC HEX BOLT, 7/8" LONG, ZINC PLATED
⑦	00 00 783	3/8"-16UNC HEX BOLT, 3-1/4" LONG (1" LONG THREAD)
⑧	00 00 784	3/8"-16UNC HEX BOLT, 4-1/4" LONG (FULL THREAD)
⑨	00 00 789	3/8"-16UNC CARRIAGE BOLT, 4-1/2" LONG
⑩	00 00 790	3/8"-16UNC CARRIAGE BOLT, 5-1/2" LONG

DIMENSIONS: INCH

QUALITY PLAN NUMBER:

## STAINLESS STEEL 316L BOLTS AND WASHER FOR NYLON CAPS

DATE: 09-10-04 DWG: G. MALECKI CHK: E.A. APP: K.S.

THIS DRAWING, THE PERTINENT ENCLOSURES, DESCRIPTIONS, CALCULATIONS ETC. AND THEIR CONTENTS ARE THE PROPERTY OF DYWIDAG SYSTEMS INTERNATIONAL, USA, INC. THEY ARE NOT ALLOWED TO BE DUPLICATED WITHOUT OUR PERMISSION. THEY ARE ALSO NOT TO BE SHOWN OR EXPLAINED FOR ANY REASON TO A THIRD PARTY OTHER THAN FOR REASONS EXPRESSLY INTENDED BY DSI'S SUBMITTAL TO THE ORIGINAL RECEIVER. THEY HAVE TO BE RETURNED UPON REQUEST.

SCALE  
1:3

REV.	DATE	NAME	NAME
1	05/01/19	S.I.	
2	05/28/20	S.I.	

PART NUMBERS:  
SEE TABLE

DRAWING NUMBER:  
00 00 770

DYWIDAG-SYSTEMS INTERNATIONAL, USA, INC.

POST TENSIONING / REINFORCING UNIT PHONE: 630-739-1100  
320 MARMON DRIVE - BOLINGBROOK, IL FAX: 630-739-1405

**DYWIDAG**

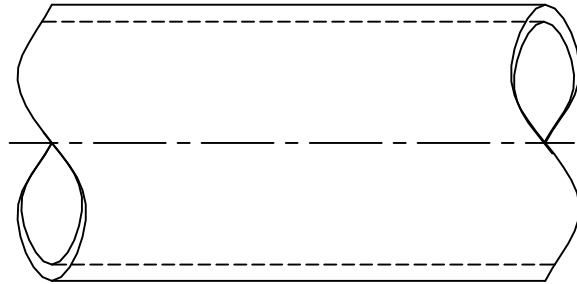
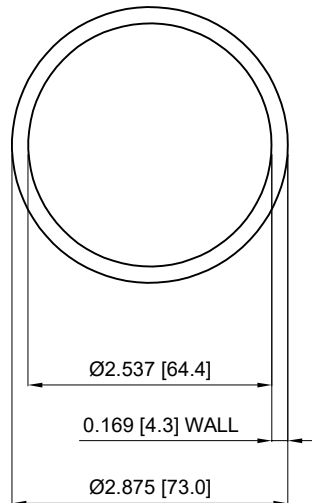

**MATERIAL:** 2 1/2" IPS DR 17 HDPE PIPE.

**SPECIFICATIONS:**

1. PIPE SHALL BE OF HIGH-DENSITY POLYETHYLENE AND SHALL HAVE A MAXIMUM DIMENSION RATIO (DR) OF 17 AS ESTABLISHED BY EITHER ASTM D3035 OR ASTM F714, AS APPROPRIATE FOR MANUFACTURING PROCESS USED..
2. PIPE SHALL HAVE A MINIMUM PRESSURE RATING OF 125 PSI.
3. MEETS REQUIREMENTS OF ASTM D3350 WITH A MINIMUM CELL CLASS OF 445574C.
4. CONTAINS ANTIOXIDANTS WITH A MINIMUM OXIDATIVE-INDUCTION TIME (OIT) ACCORDING TO ASTM D3895 OF 40 MINUTES.
5. REMOLDED FINISHED MATERIAL HAS A MINIMUM FAILURE TIME OF THREE HOURS WHEN TESTED FOR STRESS CRACK RESISTANCE USING ASTM F2136 AT AN APPLIED STRESS OF 348 PSI.

DIMENSIONS: INCH [mm] mm FOR REFERENCE ONLY		QUALITY PLAN NUMBER:		TOLERANCES: UNLESS NOTED	WEIGHT 0.63 LBS./FT.	REV.	DATE	DWG.	CHK.	PART NUMBER <b>U00055107</b>
<b>2 1/2" SMOOTH HDPE PIPE FOR FLEXIBLE FILLER TENDON</b>				MATERIAL SEE ABOVE	SCALE 1 : 2					DRAWING NUMBER: <b>U00055107</b>
				DATE: 02/27/19	DWG: I. TIRA	CHK: SI	APP: SI			
<p>THIS DRAWING, THE PERTINENT ENCLOSURES, DESCRIPTIONS, CALCULATIONS ETC. AND THEIR CONTENTS ARE THE PROPERTY OF <b>DYWIDAG SYSTEMS INTERNATIONAL, USA, INC.</b> THEY ARE NOT ALLOWED TO BE DUPLICATED WITHOUT OUR PERMISSION. THEY ARE ALSO NOT TO BE SHOWN OR EXPLAINED FOR ANY REASON TO A THIRD PARTY OTHER THAN FOR REASONS EXPRESSLY INTENDED BY DSI'S SUBMITTAL TO THE ORIGINAL RECEIVER. THEY HAVE TO BE RETURNED UPON REQUEST.</p> <p><b>DYWIDAG-SYSTEMS INTERNATIONAL, USA, INC.</b>          POST TENSIONING / REINFORCING UNIT    PHONE: 630-739-1100    <b>DYWIDAG</b>          320 MARMON DRIVE - BOLINGBROOK, IL    FAX: 630-739-1405</p>										



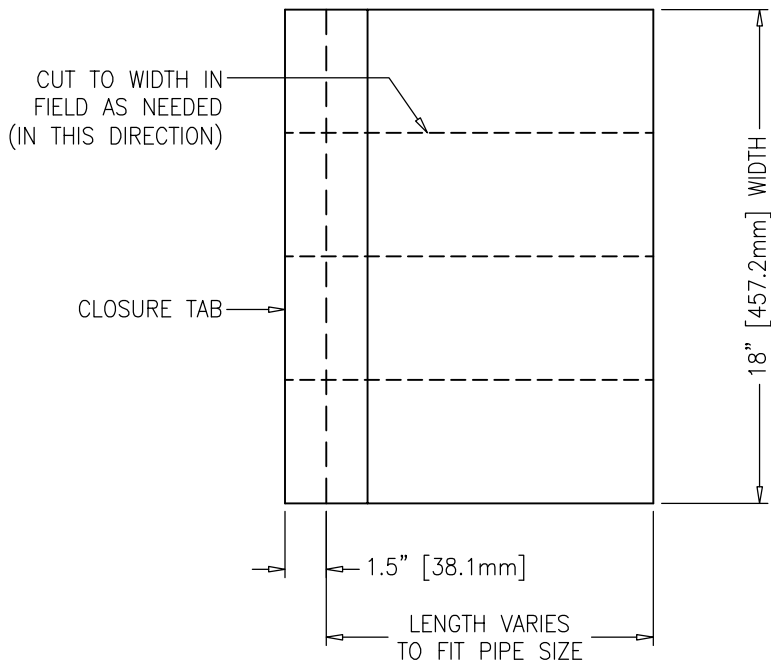

**TOP VIEW**

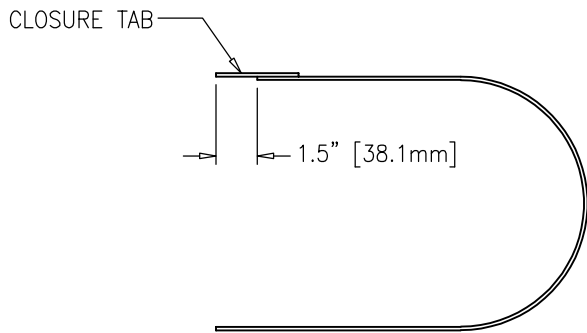

**END VIEW**  
(NOT TO SCALE)

NOTE:  
FOLLOW MANUFACTURER'S  
INSTALLATION INSTRUCTIONS.

PIPE SIZE	STRAND SYSTEM	BAR SYSTEM	HEAT SHRINK SLEEVE SIZE	PART NUMBER
2 1/2" IPS DR 17	7-0.6"	1", 1 1/4", 1 3/8"	KLNN/L 63-450 BK	U00039063
3" SDR 17	12-0.6"	1 3/4", 1 3/8"	KLNN/L 90-450 BK	U00039090
4" SDR 17	19-0.6"	2 1/2", 3"	KLNN/L 115-450 BK	U00039115
5" SDR 17	27-0.6" & 31-0.6"		KLNN/L 125-450 BK	U00039125



DIMENSIONS: INCH [mm] mm FOR REFERENCE ONLY		QUALITY PLAN NUMBER:		REV.  05-28-20	DATE	NAME	PART NUMBERS: <b>U00039063</b> <b>U00039090</b> <b>U00039115</b> <b>U00039125</b>	
<b>KLNN HEAT SHRINK SLEEVE</b>				MATERIAL: POLYOLEFIN	SCALE XX	SI		
DATE: 02-21-19	DWG: G. MALECKI	CHK: S.I.	APP: S.I.	MEETS FDOT SPECS 960-2.2.1.8 FOR FLEXIBLE FILLER			DYWIDAG-SYSTEMS INTERNATIONAL, USA, INC. 320 MARMON DRIVE - BOLINGBROOK, IL 60440 PHONE: 630-739-1100 FAX: 630-739-1405	
THIS DRAWING, THE PERTINENT ENCLOSURES, DESCRIPTIONS, CALCULATIONS ETC. AND THEIR CONTENTS ARE THE PROPERTY OF <b>DYWIDAG SYSTEMS INTERNATIONAL, USA, INC.</b> THEY ARE NOT ALLOWED TO BE DUPLICATED WITHOUT OUR PERMISSION. THEY ARE ALSO NOT TO BE SHOWN OR EXPLAINED FOR ANY REASON TO A THIRD PARTY OTHER THAN FOR REASONS EXPRESSLY INTENDED BY DSI'S SUBMITTAL TO THE ORIGINAL RECEIVER. THEY HAVE TO BE RETURNED UPON REQUEST.				DYWIDAG-SYSTEMS INTERNATIONAL, USA, INC. 320 MARMON DRIVE - BOLINGBROOK, IL 60440 PHONE: 630-739-1100 FAX: 630-739-1405		<b>DYWIDAG</b>		

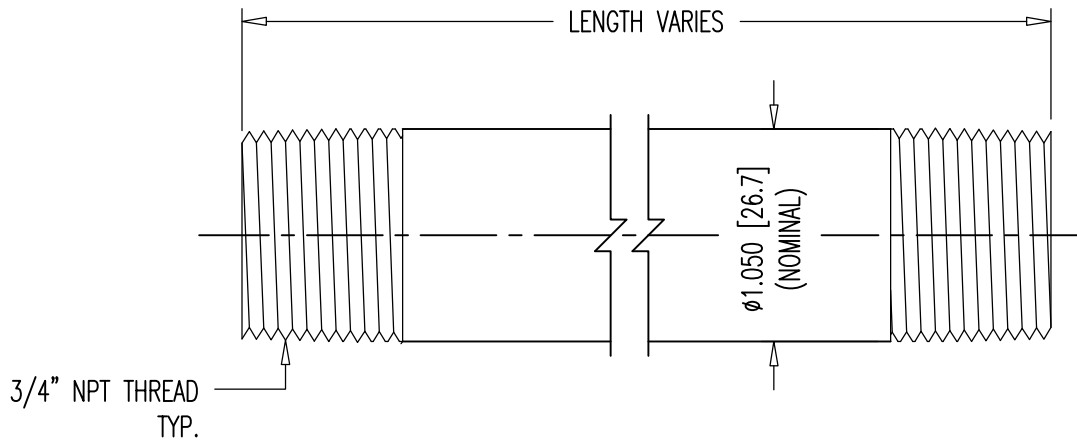

PRESSURE RATED: 150 PSI

DIMENSIONS: INCH [mm] mm FOR REFERENCE ONLY		QUALITY PLAN NUMBER: Q00000020P		REV.	DATE	NAME	ECRN	PART NUMBER: <b>00 00 878</b>
<b>3/4" NPT PIPE NIPPLES</b>				MATERIAL:	SCALE 1:1			
				DATE: 01-29-19   DWG: G. MALECKI   CHK: S.I.   APP: S.I.			SCH 40 BLACK WELDED STEEL	
THIS DRAWING, THE PERTINENT ENCLOSURES, DESCRIPTIONS, CALCULATIONS ETC. AND THEIR CONTENTS ARE THE PROPERTY OF <b>DYWIDAG SYSTEMS INTERNATIONAL,          USA, INC.</b> THEY ARE NOT ALLOWED TO BE DUPLICATED WITHOUT OUR PERMISSION. THEY ARE ALSO NOT TO BE SHOWN OR EXPLAINED FOR ANY REASON TO A THIRD PARTY OTHER THAN FOR REASONS EXPRESSLY INTENDED BY DSI'S SUBMITTAL TO THE ORIGINAL RECEIVER. THEY HAVE TO BE RETURNED UPON REQUEST.				<b>DYWIDAG-SYSTEMS INTERNATIONAL, USA, INC.</b> 320 MARMON DRIVE - BOLINGBROOK, IL 60440 PHONE: 630-739-1100      FAX: 630-739-1405				

3/4" NPT, 14 THREADS PER INCH,  
0.55" THREAD ENGAGEMENT

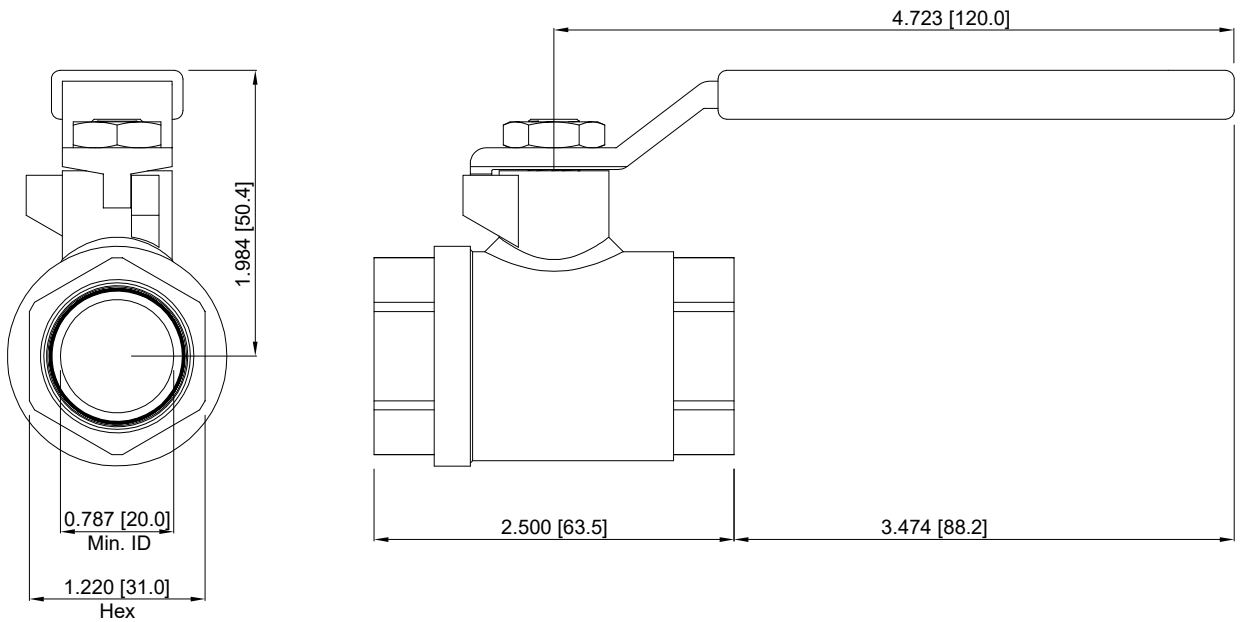
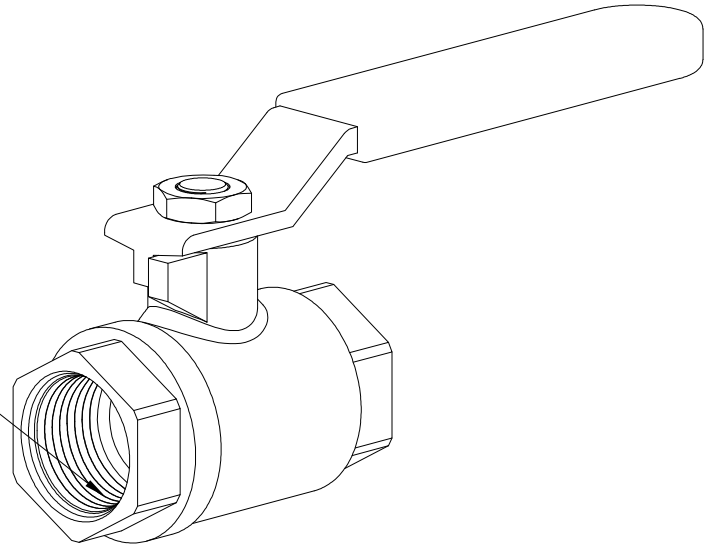

PRESSURE RATED: 150 PSI

DIMENSIONS: INCH [mm] mm FOR REFERENCE ONLY		QUALITY PLAN NUMBER:		WEIGHT	REV.	DATE	NAME	PART NUMBER
<b>3/4" BALL VALVE</b>				0.77 LBS.				<b>00 00 838</b>
				MATERIAL: BRASS	SCALE 3/4" = 1"			
DATE: 02/08/19	DWG: I. TIRA	CHK: SY	APP: SE					
THIS DRAWING, THE PERTINENT ENCLOSURES, DESCRIPTIONS, CALCULATIONS ETC. AND THEIR CONTENTS ARE THE PROPERTY OF <b>DYWIDAG SYSTEMS INTERNATIONAL, USA, INC.</b> THEY ARE NOT ALLOWED TO BE DUPLICATED WITHOUT OUR PERMISSION. THEY ARE ALSO NOT TO BE SHOWN OR EXPLAINED FOR ANY REASON TO A THIRD PARTY OTHER THAN FOR REASONS EXPRESSLY INTENDED BY DSI'S SUBMITTAL TO THE ORIGINAL RECEIVER. THEY HAVE TO BE RETURNED UPON REQUEST.				<b>DYWIDAG-SYSTEMS INTERNATIONAL, USA, INC.</b> POST TENSIONING / REINFORCING UNIT PHONE: 630-739-1100 <b>DYWIDAG</b> 320 MARMON DRIVE - BOLINGBROOK, IL FAX: 630-739-1405				

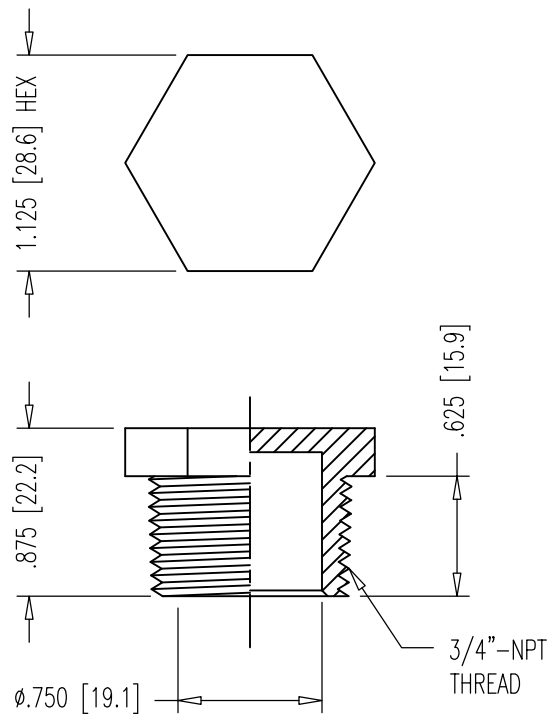

PRESSURE RATED: 150 PSI

DIMENSIONS: INCH [mm] mm FOR REFERENCE ONLY		QUALITY PLAN NUMBER:		WEIGHT .009 LBS.	REV.	DATE	NAME	PART NUMBER: <b>00 00 849</b>
<b>3/4" NPT NYLON PLUG</b>								
DATE: 03-12-19	DWG: G. MALECKI	CHK: S.I.	APP: S.I..	THIS DRAWING, THE PERTINENT ENCLOSURES, DESCRIPTIONS, CALCULATIONS ETC. AND THEIR CONTENTS ARE THE PROPERTY OF <b>DYWIDAG SYSTEMS INTERNATIONAL, USA, INC.</b> THEY ARE NOT ALLOWED TO BE DUPLICATED WITHOUT OUR PERMISSION. THEY ARE ALSO NOT TO BE SHOWN OR EXPLAINED FOR ANY REASON TO A THIRD PARTY OTHER THAN FOR REASONS EXPRESSLY INTENDED BY <b>DSI's</b> SUBMITTAL TO THE ORIGINAL RECEIVER. THEY HAVE TO BE RETURNED UPON REQUEST.				
				<b>DYWIDAG-SYSTEMS INTERNATIONAL, USA, INC.</b> 320 MARMON DRIVE - BOLINGBROOK, IL 60440 PHONE: 630-739-1100      FAX: 630-739-1405				<b>DYWIDAG</b>

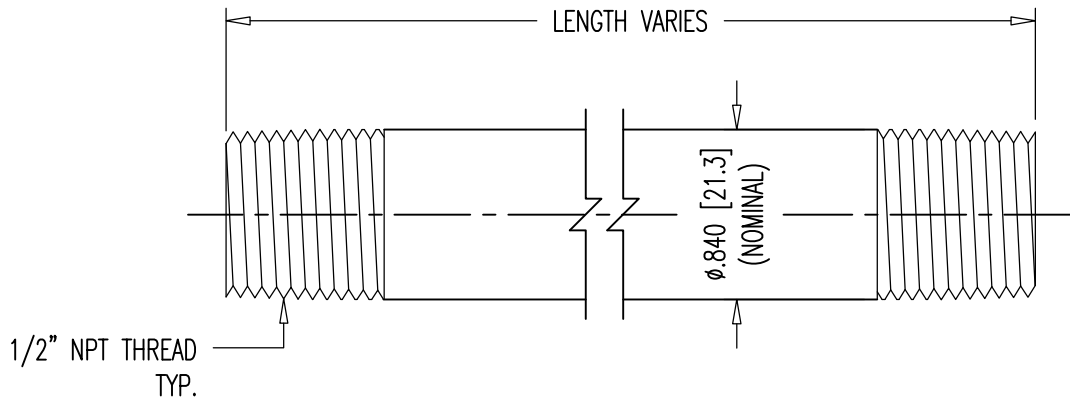

PRESSURE RATED: 150 PSI

DIMENSIONS: INCH [mm] mm FOR REFERENCE ONLY		QUALITY PLAN NUMBER: Q00000020P		REV.	DATE	NAME	PART NUMBER: <b>00 00 678</b>
<b>1/2" NPT PIPE NIPPLES</b>				MATERIAL: SCH 40 BLACK WELDED STEEL	SCALE 1:1		DRAWING NUMBER: <b>00 00 678</b>
DATE: 01-29-19	DWG: G. MALECKI	CHK: S.I.	APP: S.I.				
THIS DRAWING, THE PERTINENT ENCLOSURES, DESCRIPTIONS, CALCULATIONS ETC. AND THEIR CONTENTS ARE THE PROPERTY OF <b>DYWIDAG SYSTEMS INTERNATIONAL, USA, INC.</b> THEY ARE NOT ALLOWED TO BE DUPLICATED WITHOUT OUR PERMISSION. THEY ARE ALSO NOT TO BE SHOWN OR EXPLAINED FOR ANY REASON TO A THIRD PARTY OTHER THAN FOR REASONS EXPRESSLY INTENDED BY <b>DSI's</b> SUBMITTAL TO THE ORIGINAL RECEIVER. THEY HAVE TO BE RETURNED UPON REQUEST.				<b>DYWIDAG-SYSTEMS INTERNATIONAL, USA, INC.</b> 320 MARMON DRIVE - BOLINGBROOK, IL 60440 PHONE: 630-739-1100      FAX: 630-739-1405			

1/2" NPT, 14 THREADS PER INCH,  
0.53" THREAD ENGAGEMENT

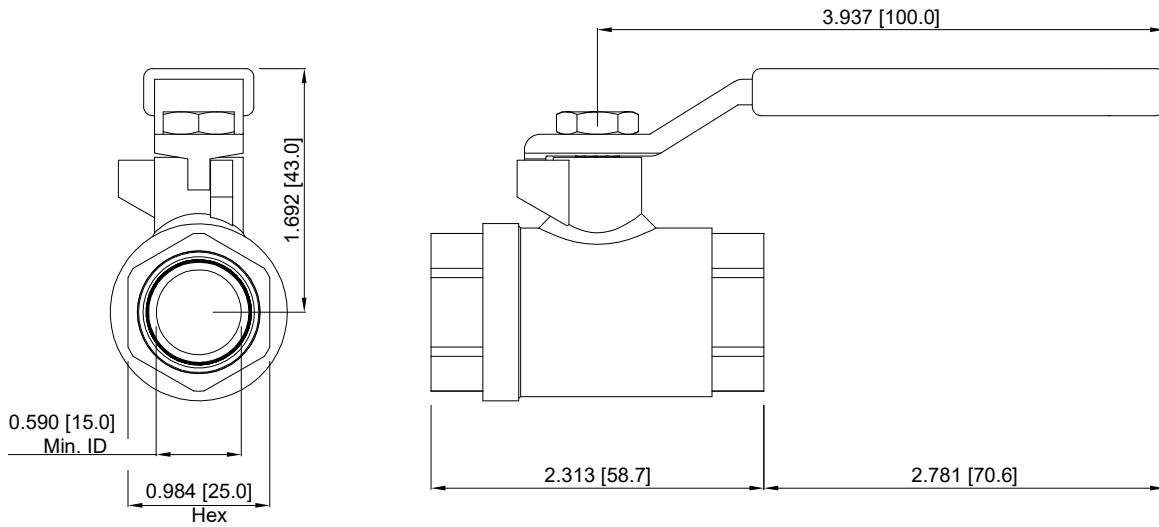
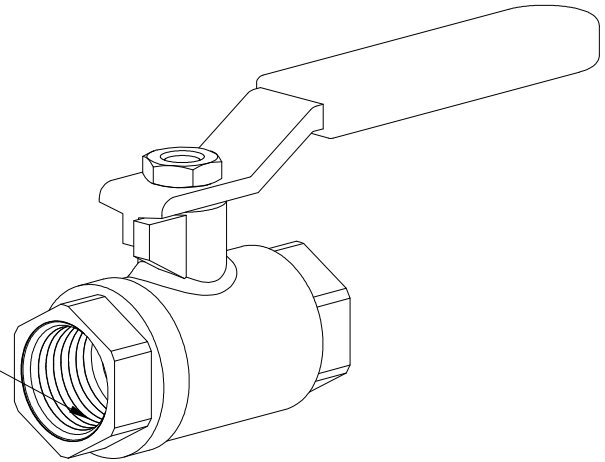

PRESSURE RATED: 150 PSI

DIMENSIONS: INCH [mm] mm FOR REFERENCE ONLY		QUALITY PLAN NUMBER:		WEIGHT -- LBS.	REV.	DATE	NAME	PART NUMBER <b>00 00 638</b>
<b>1/2" BALL VALVE</b>					SCALE 3/4" = 1"			
				MATERIAL: BRASS				
DATE: 02/08/19	DWG: I. TIRA	CHK: SI	APP: SI	<p><b>DYWIDAG-SYSTEMS INTERNATIONAL, USA, INC.</b>          POST TENSIONING / REINFORCING UNIT PHONE: 630-739-1100 <b>DYWIDAG</b>          320 MARMON DRIVE - BOLINGBROOK, IL FAX: 630-739-1405</p>				
<p>THIS DRAWING, THE PERTINENT ENCLOSURES, DESCRIPTIONS, CALCULATIONS ETC. AND THEIR CONTENTS ARE THE PROPERTY OF <b>DYWIDAG SYSTEMS INTERNATIONAL, USA, INC.</b> THEY ARE NOT ALLOWED TO BE DUPLICATED WITHOUT OUR PERMISSION. THEY ARE ALSO NOT TO BE SHOWN OR EXPLAINED FOR ANY REASON TO A THIRD PARTY OTHER THAN FOR REASONS EXPRESSLY INTENDED BY DSI'S SUBMITTAL TO THE ORIGINAL RECEIVER. THEY HAVE TO BE RETURNED UPON REQUEST.</p>								



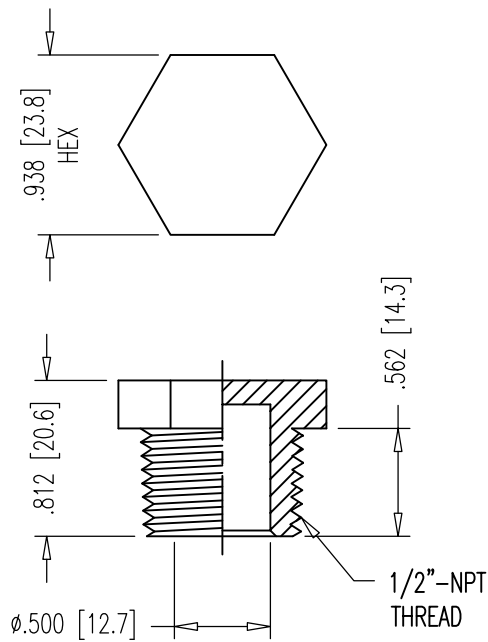

PRESSURE RATED: 150 PSI

DIMENSIONS: INCH [mm] mm FOR REFERENCE ONLY		QUALITY PLAN NUMBER:		WEIGHT .006 LBS.	REV.	DATE	NAME	ECRN	PART NUMBER: <b>00 00 649</b>
<b>1/2" NPT NYLON PLUG</b>									
				DATE: 03-12-19	DWG: G. MALECKI	CHK: S.I.	APP: S.I.	MATERIAL: NYLON 6 COLOR: WHITE	
THIS DRAWING, THE PERTINENT ENCLOSURES, DESCRIPTIONS, CALCULATIONS ETC. AND THEIR CONTENTS ARE THE PROPERTY OF <b>DYWIDAG SYSTEMS INTERNATIONAL, USA, INC.</b> THEY ARE NOT ALLOWED TO BE DUPLICATED WITHOUT OUR PERMISSION. THEY ARE ALSO NOT TO BE SHOWN OR EXPLAINED FOR ANY REASON TO A THIRD PARTY OTHER THAN FOR REASONS EXPRESSLY INTENDED BY <b>DSI's</b> SUBMITTAL TO THE ORIGINAL RECEIVER. THEY HAVE TO BE RETURNED UPON REQUEST.				<b>DYWIDAG-SYSTEMS INTERNATIONAL, USA, INC.</b> 320 MARMON DRIVE - BOLINGBROOK, IL 60440 PHONE: 630-739-1100      FAX: 630-739-1405					

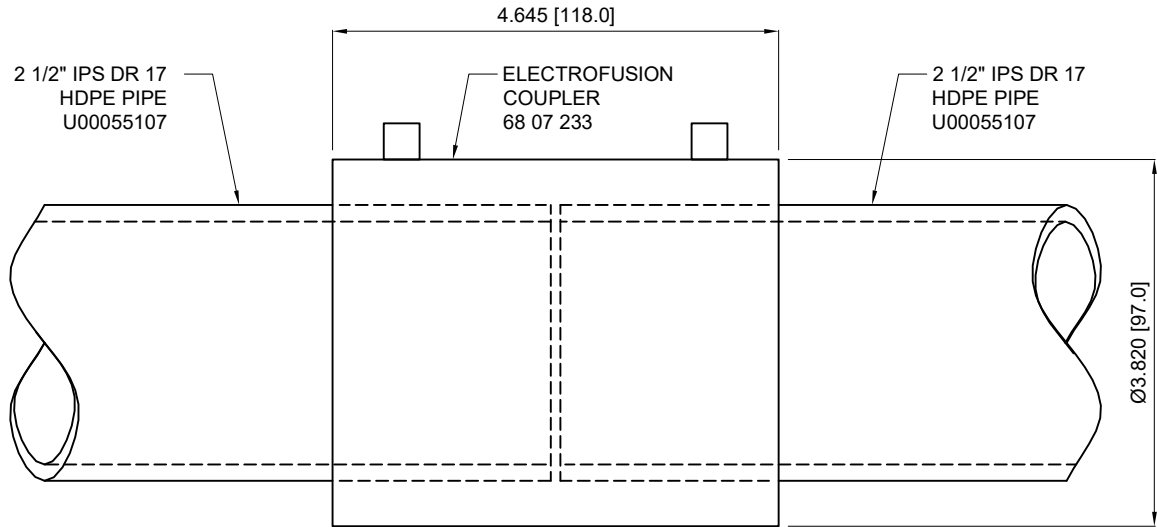

**INSTALLATION PROCEDURE:**

(SEE MANUFACTURER INSTRUCTION MANUAL FOR DETAILED INSTRUCTIONS)

1. CUT PIPE ENDS PRECISELY AT RIGHT ANGLES TO THE PIPE AXIS.
2. CLEAN BOTH PIPE ENDS CAREFULLY.
3. SCRAP BOTH PIPES ENDS AS REQUIRED TO REMOVE THE OXIDE LAYER COMPLETELY
4. CLEAN BOTH PIPE ENDS WITH CONCENTRATED ISOPROPYL ALCOHOL.
5. USE REROUNDING TOOLS TO CORRECT OVAL PIPE IF NEEDED.
6. USE ALIGNMENT CLAMPS TO SECURE THE ALIGNMENT OF CONNECTED PIPES
7. PROVIDE SUPPORT TO THE PIPE AND COUPLER TO PREVENT ANY MOVEMENT.
8. ENSURE THERE IS NO EXISTING GAPS BETWEEN COUPLE AND PIPE FACE.
9. ATTACH LEADS OF THE FUSION PROCESSOR TO THE COUPLER.
10. SCAN THE BARCODE ON THE COUPLER AND CONFIRM THE COUPLER'S SIZE ON THE PROCESSOR SCREEN.
11. INITIATE FUSION PROCESS.
12. UNPLUG THE LEADS AS SOON AS THE FUSION PROCESS ENDS.
13. CHECK COOLING TIME OF THE PROVIDED COUPLER BASED ON COUPLER'S SIZE.
14. DO NOT ALLOW MOVEMENT OR APPLIED PRESSURE ON THE JOINTS BEFORE COOLING TIME ENDS.

DIMENSIONS: INCH [mm] mm FOR REFERENCE ONLY		QUALITY PLAN NUMBER:		WEIGHT 0.770 LBS	REV.	DATE	DWG.	CHK.	PART NUMBER <b>68 07 233</b>
<b>ELECTROFUSION COUPLER CONNECTION FOR 2 1/2" IPS DR 17 HDPE PIPE</b>					SCALE 1 : 2				DRAWING NUMBER: <b>68 07 233</b>
DATE: 02/27/19	DWG: I. TIRA	CHK: SI	APP: SI	MATERIAL: COMPOSITE					

THIS DRAWING, THE PERTINENT ENCLOSURES, DESCRIPTIONS, CALCULATIONS ETC. AND THEIR CONTENTS ARE THE PROPERTY OF **DYWIDAG SYSTEMS INTERNATIONAL, USA, INC.** THEY ARE NOT ALLOWED TO BE DUPLICATED WITHOUT OUR PERMISSION. THEY ARE ALSO NOT TO BE SHOWN OR EXPLAINED FOR ANY REASON TO A THIRD PARTY OTHER THAN FOR REASONS EXPRESSLY INTENDED BY DSI'S SUBMITTAL TO THE ORIGINAL RECEIVER. THEY HAVE TO BE RETURNED UPON REQUEST.

**DYWIDAG-SYSTEMS INTERNATIONAL, USA, INC.**  
 POST TENSIONING / REINFORCING UNIT PHONE: 630-739-1100  
 320 MARMON DRIVE - BOLINGBROOK, IL FAX: 630-739-1405

