

CAP END VIEW

CAUTION: WHEN PRESSURIZING GROUT CAPS, DO NOT STAND BEHIND CAPS!

CAUTION: WHEN USING HIGH STRENGTH DYWIDAG THREADBAR (GRADE 150)
 DO NOT WELD TO BAR.
 DO NOT USE BAR AS GROUND CONNECTION FOR WELDING.
 DO NOT ALLOW HOT SLAG OR SPARKS TO TOUCH BAR.
 DO NOT DAMAGE BAR SURFACE.
 DO NOT USE BARS WITH KINKS OR SHARP BENDS.
 FAILURE TO HEED THIS WARNING COULD CAUSE BAR TO BREAK RESULTING IN INJURY OR DAMAGE

WARNING: READ AND COMPLY WITH ALL APPLICABLE SAFETY AND OPERATING INSTRUCTIONS AND WARNINGS FOR THREADBAR STRESSING BEFORE STARTING ANY WORK OR OPERATION.

MATERIAL LIST		
PART NO.	DESCRIPTION	MATERIAL SPECIFICATION
B36E CUT	1-3/8" (36mm) THREADBAR	ASTM A722 TYPE II STEEL
B36E22510 OR B36E22610	7"x7.5"x1.75" SQ. OR 5"x9.5"x2" RECT. BEARING PL. WITH 2-1/4" OD x 3/16" WALL, 5-1/2" LONG MECHANICAL TUBING AND BOLT HOLES, GALV.	STEEL PLATE: ASTM A36, MECHANICAL TUBE: ASTM A512, A513 OR A519, ASSEMBLY GALVANIZED
B36E50700	NYLON BAR GROUT CAP WITH O-RING	CAP: NYLON 6, 20% GLASS FIBER FILLED O-RING: EPDM
00 00 783 00 00 774	(4) 3/8"-16UNC HEX BOLTS, 3-1/4" LONG 3/8" NARROW WASHERS	316L STAINLESS STEEL
B36E24210	1-3/8" GROUTABLE ANCHOR NUT	FORGING, NORMALIZED C1045
00 00 649	1/2" NPT PLUG	NYLON 6, WHITE
00 00 678	1/2" NPT NIPPLE, LENGTH AS REQ'D (TEMPORARY)	SCH 40 BLACK WELDED STEEL
00 00 878	3/4" NPT NIPPLE, LENGTH AS REQ'D (TEMPORARY)	SCH 40 BLACK WELDED STEEL
00 00 849	3/4" NPT PLUG	NYLON 6, WHITE
00 00 634	1/2" NPT BALL VALVE (TEMPORARY)	PVC
00 00 834	3/4" NPT BALL VALVE (TEMPORARY)	PVC
U00220200	2-3/8" (59mm) CORRUGATED DUCT	POLYPROPYLENE
U00220205	(OPTIONAL) 2-3/8" (59mm) DUCT COUPLER	POLYPROPYLENE
U00044030	HEAT SHRINK SLEEVE, PMA-90/30-450-BK	ACCORD. TO FDOT SPEC. P.T. SEC. 960-2.2.1.8
ANS	TEFLON TAPE OR PASTE	-

- NOTES:**
- USERS SHALL REFER TO FDOT STANDARD SPECIFICATIONS AND PROJECT SPECIFIC CRITERIA FOR TENDON INSTALLATION, STRESSING, & GROUTING.
 - REQUIRED REINFORCING BARS ARE NOT SHOWN ON THIS DRAWING.
 - MAXIMUM ANGULAR MISALIGNMENT WHEN USING ANCHOR NUT: ±2°.
 - CENTER TO CENTER, END AND EDGE DISTANCE DEPENDS ON THE LOCATION OF THE BAR AND CONCRETE STRENGTH. (SEE TABLE).
 - C/C DISTANCE = 2 X END DISTANCE - 2 X CONCRETE COVER (2" ASSUMED). TIGHTER C/C DISTANCE SHOULD BE EVALUATED.
 - DUCT IS DELIVERED IN STRAIGHT SECTIONS AND IS NOT INTENDED TO BE COILED.
 - BURSTING REINFORCEMENT IS NOT SHOWN AND WILL BE INCLUDED WITH THE SHOP DRAWINGS.
 - THREADBAR TENDONS ARE STRESSED FROM ONE END ONLY.

Plate Type	fci, ksi	Depth, D (in)	Minimum distances, in	
			End dist, E	c/c dist, C
Square	5.5	11.0	5.89	7.78
	5.0	12.0	6.41	8.83
	4.5	13.0	6.98	9.95
Rectangular	4.0	15.0	8.03	12.05
	5.0	9.0	8.55	13.10
	4.5	10.0	9.50	15.00
4.0	12.0	11.40	18.80	

Plate Type	Part No	Width, in	Length, in	Thickness, in
Square	B36E22510	7	7.5	1.75
Rectangular	B36E22610	5	9.5	2

DIMENSIONS: INCH

INTERNAL GROUTED SYSTEM FOR 1-3/8" (36mm) THREADBAR ASSEMBLY

DATE: 08-01-19 DWG: G. MALECKI CHK: S.I. APP: S.I.

THIS DRAWING, THE PERTINENT ENCLOSURES, DESCRIPTIONS, CALCULATIONS ETC. AND THEIR CONTENTS ARE THE PROPERTY OF DYWIDAG SYSTEMS INTERNATIONAL, USA, INC. THEY ARE NOT ALLOWED TO BE DUPLICATED WITHOUT OUR PERMISSION. THEY ARE ALSO NOT TO BE SHOWN OR EXPLAINED FOR ANY REASON TO A THIRD PARTY OTHER THAN FOR REASONS EXPRESSLY INTENDED BY DSI'S SUBMITTAL TO THE ORIGINAL RECEIVER. THEY HAVE TO BE RETURNED UPON REQUEST.

REV.	DATE	NAME

SCALE: 1:3

DYWIDAG-SYSTEMS INTERNATIONAL, USA, INC.
 POST TENSIONING / REINFORCING UNIT PHONE: 630-739-1100
 320 MARMON DRIVE - BOLINGBROOK, IL FAX: 630-739-1405

DYWIDAG

RIGHT HAND THREAD

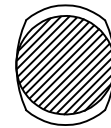
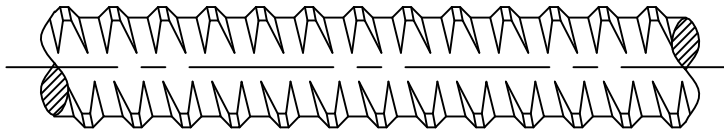

	<u>PART NUMBERS</u>	<u>SPECIFICATIONS</u>
FOR BARE BAR:	B36E CUT	ASTM A722 TYPE II

<u>PHYSICAL PROPERTIES</u>	
EFFECTIVE AREA:	1.58 SQ.IN. (1019 SQ.mm)
ULTIMATE STRENGTH:	150 KSI (1034 N/SQ.mm)
ULTIMATE LOAD:	237 KIPS (1054 KN)
YIELD LOAD:	191.2 KIPS (851 KN)
WEIGHT:	5.56 LBS./FT. (8.27 Kg/m)
MAX. BAR ϕ INCL. RIBS:	1.63 IN. (41.4mm)
AVERAGE CORE ϕ :	1.40 IN. (35.6mm)
PITCH:	0.709 IN. (18.0mm)

DIMENSIONS: INCH (mm) mm FOR REFERENCE ONLY		QUALITY PLAN NUMBER: QB00000050B		REV.				DATE	NAME	ECRN	PART NUMBER: B36E CUT
1-3/8"Ø THREADBAR GRADE 150 KSI				MATERIAL: SEE ABOVE		SCALE NTS					DRAWING NUMBER: B36E CUT
DATE: 12-23-91	DWG: G. MALECKI	CHK: H.K.	APP: K.S.								
<small>THIS DRAWING, THE PERTINENT ENCLOSURES, DESCRIPTIONS, CALCULATIONS ETC. AND THEIR CONTENTS ARE THE PROPERTY OF DYWIDAG SYSTEMS INTERNATIONAL, USA, INC. THEY ARE NOT ALLOWED TO BE DUPLICATED WITHOUT OUR PERMISSION. THEY ARE ALSO NOT TO BE SHOWN OR EXPLAINED FOR ANY REASON TO A THIRD PARTY OTHER THAN FOR REASONS EXPRESSLY INTENDED BY DSI'S SUBMITTAL TO THE ORIGINAL RECEIVER. THEY HAVE TO BE RETURNED UPON REQUEST.</small>				DYWIDAG-SYSTEMS INTERNATIONAL, USA, INC. 320 MARMON DRIVE - BOLINGBROOK, IL 60440 PHONE: 630-739-1100 FAX: 630-739-1405							

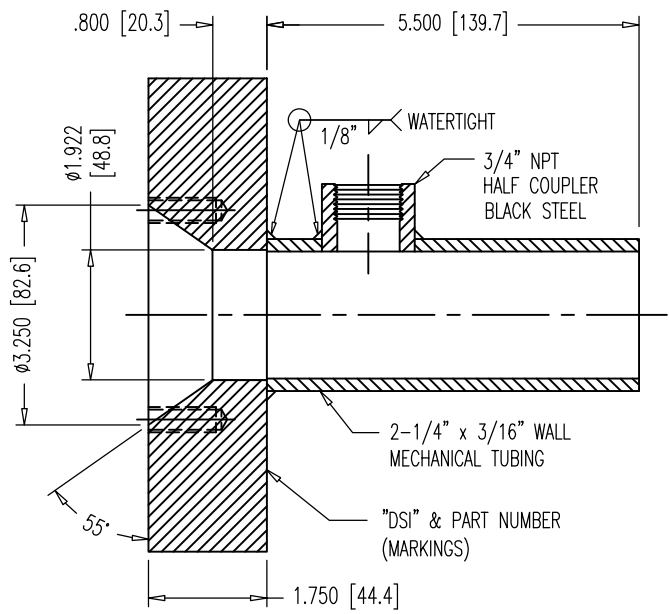
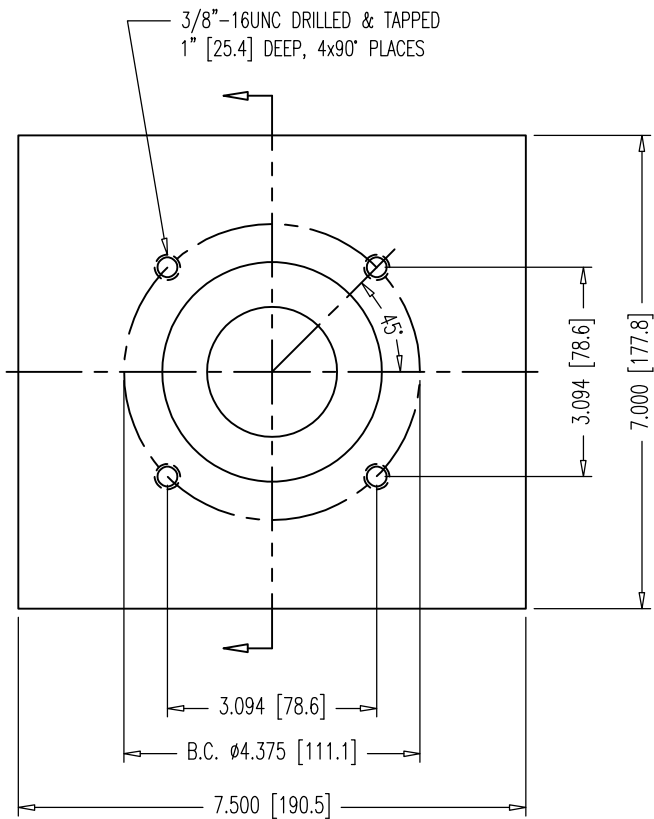

PLATE MATERIAL: ASTM A36
MECHANICAL TUBE MATERIAL
SHALL BE A512, A513 OR A519

NOTES:

1. PLATE AND PIPE GALVANIZED ACCORDING TO ASTM A123 AFTER WELDING.
2. DIMENSIONS AND TOLERANCES APPLY TO UNCOATED PLATE AND TUBING.
3. ENSURE THREADABILITY OF TAPPED HOLES IN PLATES IF THEY ARE REQUIRED.
4. 59mm DUCT U00220200 FITS OVER TUBING.

DIMENSIONS: INCH [mm] mm FOR REFERENCE ONLY		QUALITY PLAN NUMBER: QBE0021200L		TOLERANCES: ±.020 UNLESS NOTED	WEIGHT: 25.8 LBS.	REV.	DATE	NAME	ECRN	PART NUMBER: B36E22510
SQUARE BEARING PLATE WITH EXIT PIPE FOR 1-3/8" THREADBAR				MATERIAL: SEE ABOVE	SCALE 1:3					DRAWING NUMBER: B36E22510
DATE: 08-16-07	DWG: G. MALECKI	CHK: S.N.	APP: E.A.							

THIS DRAWING, THE PERTINENT ENCLOSURES, DESCRIPTIONS, CALCULATIONS ETC. AND THEIR CONTENTS ARE THE PROPERTY OF **DYWIDAG SYSTEMS INTERNATIONAL, USA, INC.** THEY ARE NOT ALLOWED TO BE DUPLICATED WITHOUT OUR PERMISSION. THEY ARE ALSO NOT TO BE SHOWN OR EXPLAINED FOR ANY REASON TO A THIRD PARTY OTHER THAN FOR REASONS EXPRESSLY INTENDED BY **DSI's** SUBMITTAL TO THE ORIGINAL RECEIVER. THEY HAVE TO BE RETURNED UPON REQUEST.

DYWIDAG-SYSTEMS INTERNATIONAL, USA, INC.
320 MARMON DRIVE - BOLINGBROOK, IL 60440
PHONE: 630-739-1100 FAX: 630-739-1405



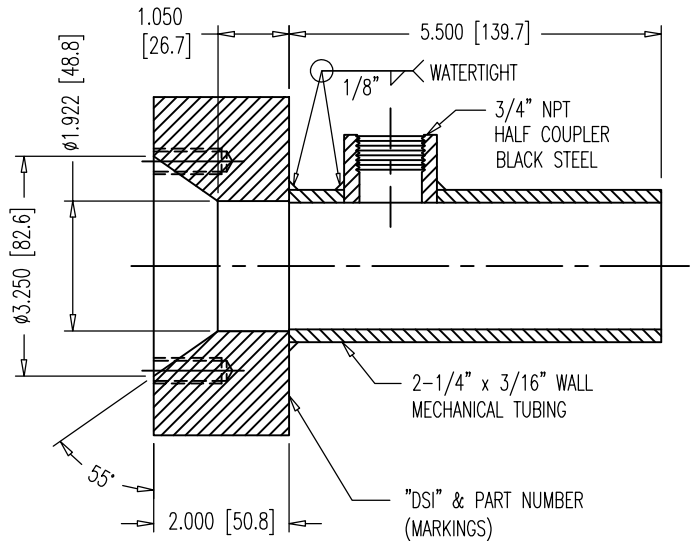
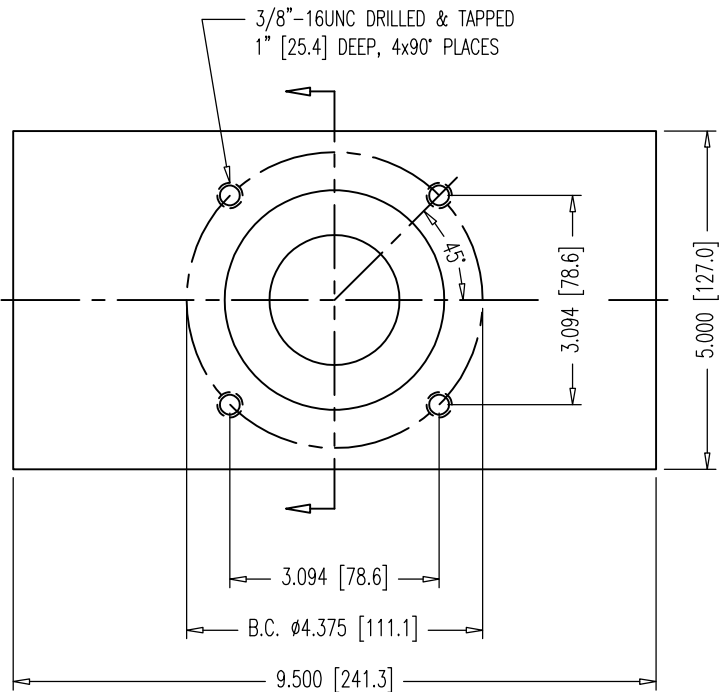

PLATE MATERIAL: ASTM A36
MECHANICAL TUBE MATERIAL
SHALL BE A512, A513 OR A519

NOTES:

1. PLATE AND PIPE GALVANIZED ACCORDING TO ASTM A123 AFTER WELDING.
2. DIMENSIONS AND TOLERANCES APPLY TO UNCOATED PLATE AND TUBING.
3. ENSURE THREADABILITY OF TAPPED HOLES IN PLATES IF THEY ARE REQUIRED.
4. 59mm DUCT U00220200 FITS OVER TUBING.

DIMENSIONS: INCH [mm] mm FOR REFERENCE ONLY		QUALITY PLAN NUMBER: QBE0021200L		TOLERANCES: \pm .020 UNLESS NOTED	WEIGHT: 26.5 LBS.	REV.	DATE	NAME	PART NUMBER: B36E22610
RECT. BEARING PLATE WITH EXIT PIPE FOR 1-3/8" THREADBAR				MATERIAL: SEE ABOVE	SCALE: 1:3				DRAWING NUMBER: B36E22610
DATE: 08-16-07	DWG: G. MALECKI	CHK: S.N.	APP: E.A.	THIS DRAWING, THE PERTINENT ENCLOSURES, DESCRIPTIONS, CALCULATIONS ETC. AND THEIR CONTENTS ARE THE PROPERTY OF DYWIDAG SYSTEMS INTERNATIONAL, USA, INC. THEY ARE NOT ALLOWED TO BE DUPLICATED WITHOUT OUR PERMISSION. THEY ARE ALSO NOT TO BE SHOWN OR EXPLAINED FOR ANY REASON TO A THIRD PARTY OTHER THAN FOR REASONS EXPRESSLY INTENDED BY DSI'S SUBMITTAL TO THE ORIGINAL RECEIVER. THEY HAVE TO BE RETURNED UPON REQUEST.					
DYWIDAG-SYSTEMS INTERNATIONAL, USA, INC. 320 MARMON DRIVE - BOLINGBROOK, IL 60440 PHONE: 630-739-1100 FAX: 630-739-1405									



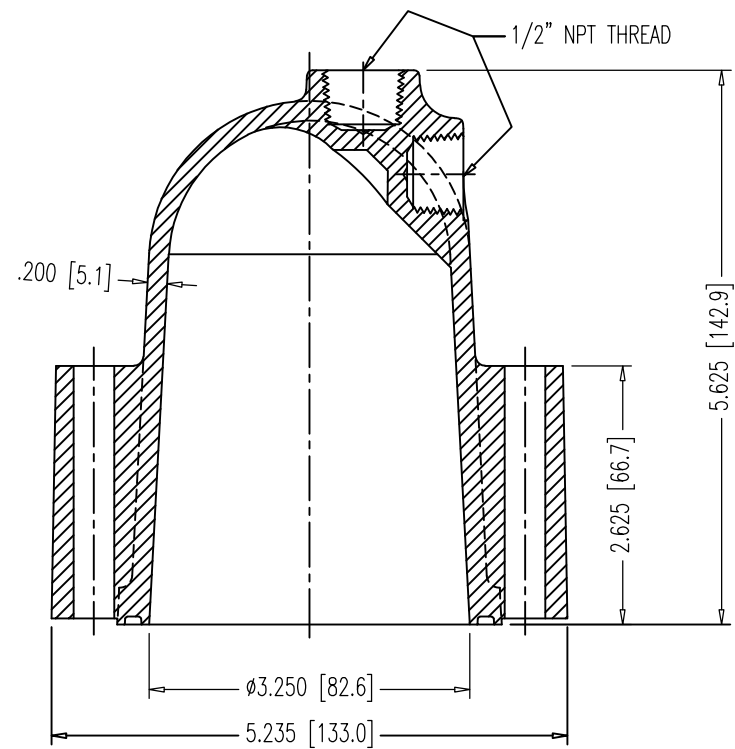

SECTION A-A

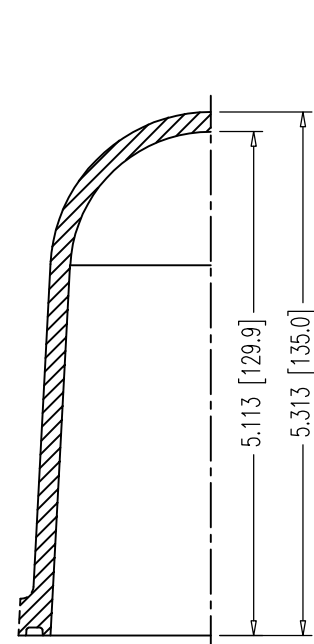

SECTION B-B

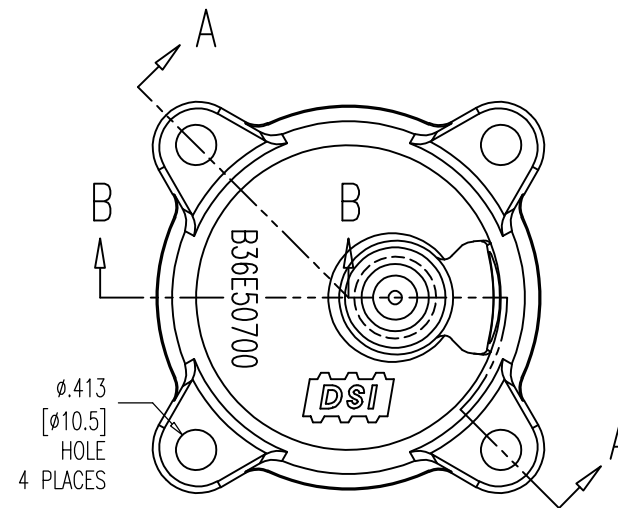

TOP VIEW

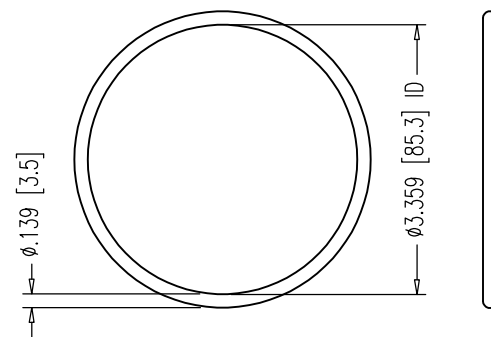
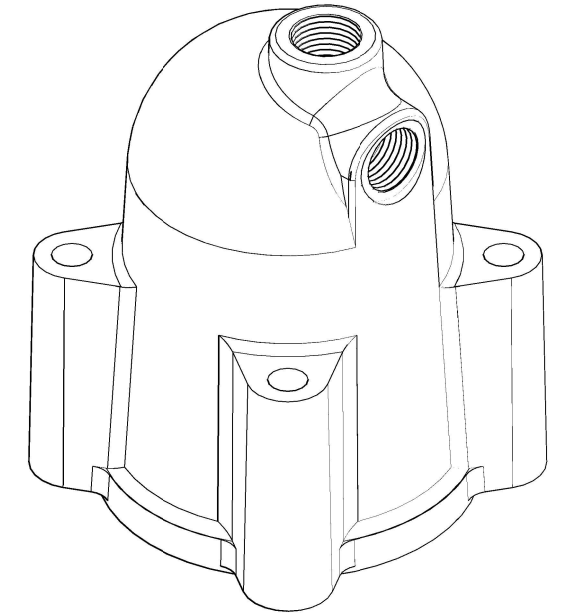

O-RING MATERIAL:
 EPDM MEETING FDOT
 SPECIFICATIONS 960-2.2.1.7.
 #237 O-RING
 3-3/8" x 3-5/8" x 1/8"
 SCALE: NTS

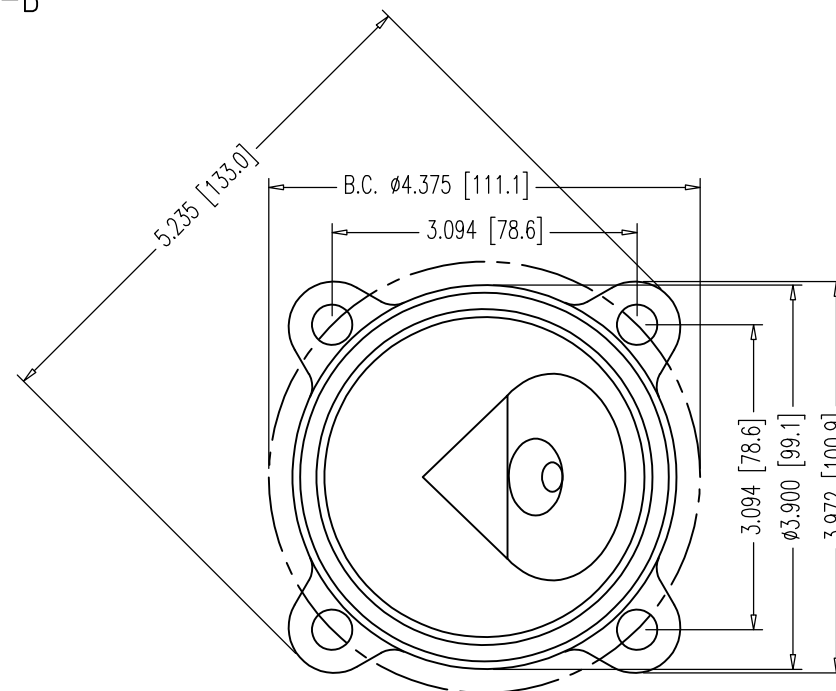

BOTTOM VIEW

NOTES:

1. USE 3/8"-16UNC 316L S.S. HEX BOLTS, 3-1/4" LONG 00 00 783 W/SMALL DIA. WASHER 00 00 774.
2. INSTALL O-RING IN GROOVE USING DROPS OF LIQUID ADHESIVE BEFORE SHIPPING.
3. THE NYLON CONFORMS TO ASTM D5989, WITH CELL CLASSIFICATION S-PA0401 (ULTIMATE STRENGTH 10,000 PSI MIN., WITH UV STABILIZER ADDED).
4. DRILL 1/2" [12.7] HOLE IN PORT BEING USED-CAUTION-RECOMMEND USING HOLE SAW BIT OR SPADE BIT (BY OTHERS), BE CAREFULL TO PREVENT DAMAGE TO THREADS OR CAP.
5. WHEN PRESSURIZING GROUT CAPS, DO NOT STAND BEHIND CAPS!

DIMENSIONS: INCH [mm] mm FOR REFERENCE ONLY		QUALITY PLAN NUMBER: QS60072300P		TOLERANCES: SEE TOLERANCE NOTE	WEIGHT 0.817 LBS.	REV. 1	DATE 10/04/18	NAME S.I.	PART NUMBER: B36E50700
BAR GROUT CAP WITH O-RING FOR ALL 1" & 1-1/4" NUTS AND 1-3/8" ANCHOR NUT				MATERIAL: NYLON 6 20% GLASS FIBER FILLED COLOR: BLACK	SCALE 1:2 UNLESS NOTED				DRAWING NUMBER: B36E50700
DATE: 10-02-06	DWG: G. MALECKI	CHK: E.A.	APP: K.S.	THIS DRAWING, THE PERTINENT ENCLOSURES, DESCRIPTIONS, CALCULATIONS ETC. AND THEIR CONTENTS ARE THE PROPERTY OF DYWIDAG SYSTEMS INTERNATIONAL, USA, INC. THEY ARE NOT ALLOWED TO BE DUPLICATED WITHOUT OUR PERMISSION. THEY ARE ALSO NOT TO BE SHOWN OR EXPLAINED FOR ANY REASON TO A THIRD PARTY OTHER THAN FOR REASONS EXPRESSLY INTENDED BY DSI'S SUBMITTAL TO THE ORIGINAL RECEIVER. THEY HAVE TO BE RETURNED UPON REQUEST.					
DYWIDAG-SYSTEMS INTERNATIONAL, USA, INC. 320 MARMON DRIVE - BOLINGBROOK, IL 60440 PHONE: 630-739-1100 FAX: 630-739-1405									



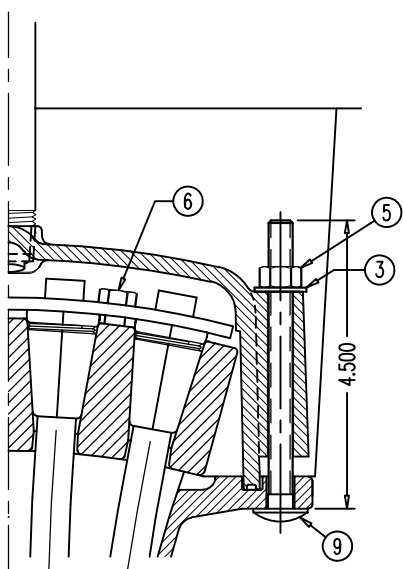

KEEPER PLATE 68 04 2637 ON
WEDGE PLATE 68 04 2534A &
NYLON CAP 68 04 2539 ON
FLAT ANCHOR 68 04 2548

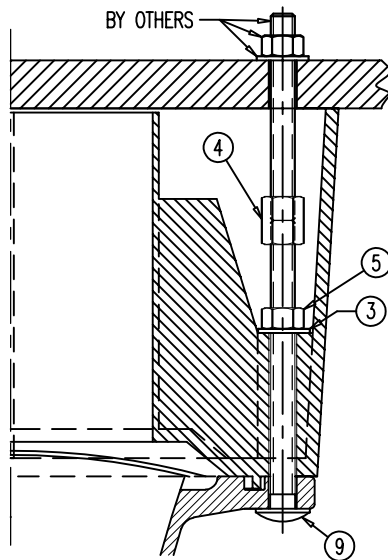

POCKET FORMER 68 04 2640
ON FLAT ANCHOR 68 04 2548

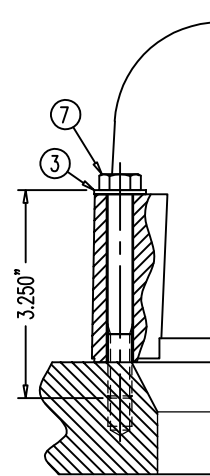

NYLON BAR CAP B36E50700 OR 50700A
ON GALV. BEARING PLATE
B26E22510, 22610, 22700, 22800,
B32E22510, 22610, 22700, 22800,
B36E22410, 22420, 22910, 22510,
22610, 22700, 22800 & NYLON
BAR CAP B66E50700 OR 50700A
ON GALV. BEARING PLATE B66E22700

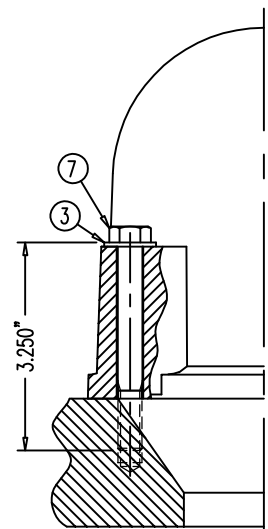

NYLON BAR CAP
B46M50700
OR 50700A
ON GALV.
BEARING PLATE
B46E22700 &
B46E22800

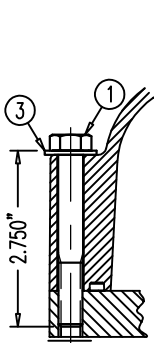

NYLON CAP
68 07 7230 OR 7230A
ON MPA 68 07 248

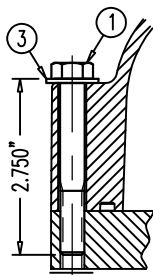

NYLON CAP
68 12 7230 OR 7230A
ON MPA 68 12 248

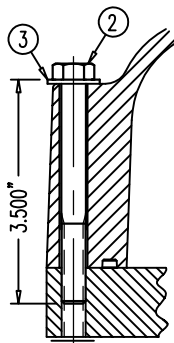

NYLON CAP
68 19 7230 OR 7230A
ON MPA 68 19 248

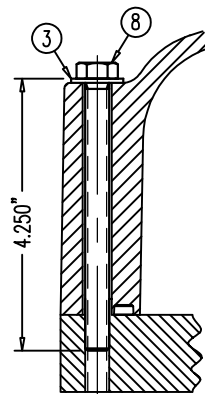

NYLON CAP
68 27 7230 OR 7230A
ON MPA 68 27 248

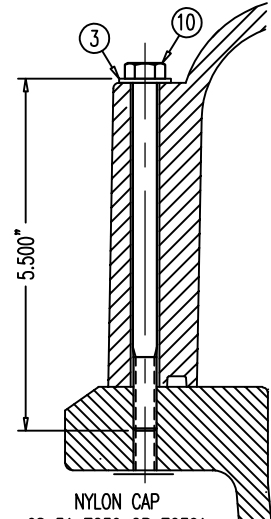

NYLON CAP
68 31 7230 OR 7230A
ON MPA 68 31 248

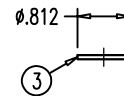

TYPE A NARROW WASHER
FOR 3/8"-UNC BOLT

NOTE:
THE 316L S.S. BOLTS ARE SPECIAL ORDER.
ALL WASHERS, HEX NUTS & COUPLERS HAVE
NO MARKINGS.

POS.	PART NUMBER	DISCRIPTION (ALL PARTS 316L STAINLESS STEEL UNLESS NOTED)
①	00 00 771	3/8"-16UNC HEX BOLT, 2-3/4" LONG (1" LONG THREAD)
②	00 00 772	3/8"-16UNC HEX BOLT, 3-1/2" LONG (1" LONG THREAD)
③	00 00 774	TYPE A NARROW WASHER FOR 3/8"-UNC BOLT
④	00 00 776	3/8"-16UNC COUPLER, ZINC COATED
⑤	00 00 777	3/8"-16UNC HEX NUT
⑥	00 00 778	5/16"-18UNC HEX BOLT, 7/8" LONG, ZINC PLATED
⑦	00 00 783	3/8"-16UNC HEX BOLT, 3-1/4" LONG (1" LONG THREAD)
⑧	00 00 784	3/8"-16UNC HEX BOLT, 4-1/4" LONG (FULL THREAD)
⑨	00 00 789	3/8"-16UNC CARRIAGE BOLT, 4-1/2" LONG
⑩	00 00 790	3/8"-16UNC CARRIAGE BOLT, 5-1/2" LONG

DIMENSIONS: INCH

QUALITY PLAN NUMBER:

STAINLESS STEEL 316L BOLTS AND WASHER FOR NYLON CAPS

DATE: 09-10-04 DWG: G. MALECKI CHK: E.A. APP: K.S.

THIS DRAWING, THE PERTINENT ENCLOSURES, DESCRIPTIONS, CALCULATIONS ETC. AND THEIR CONTENTS ARE THE PROPERTY OF DYWIDAG SYSTEMS INTERNATIONAL, USA, INC. THEY ARE NOT ALLOWED TO BE DUPLICATED WITHOUT OUR PERMISSION. THEY ARE ALSO NOT TO BE SHOWN OR EXPLAINED FOR ANY REASON TO A THIRD PARTY OTHER THAN FOR REASONS EXPRESSLY INTENDED BY DSI'S SUBMITTAL TO THE ORIGINAL RECEIVER. THEY HAVE TO BE RETURNED UPON REQUEST.

SCALE
1:3

REV.	DATE	NAME	NAME
1	05/01/19	S.I.	
2	05/28/20	S.I.	

PART NUMBERS:
SEE TABLE

DRAWING NUMBER:
00 00 770

DYWIDAG-SYSTEMS INTERNATIONAL, USA, INC.
POST TENSIONING / REINFORCING UNIT PHONE: 630-739-1100
320 MARMON DRIVE - BOLINGBROOK, IL FAX: 630-739-1405



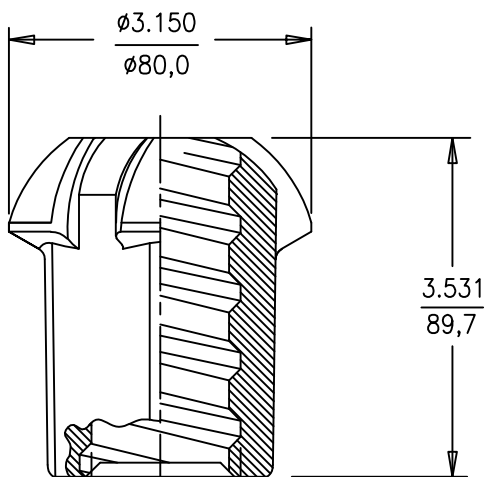
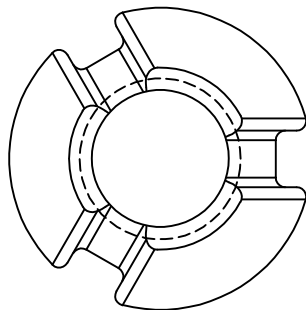

THREAD ACCORDING TO TOLERANCE DRAWING 8341/722
 MINOR DIAMETER: 1.429 - 1.433 (36.30 - 36.40)
 MINOR DIA.

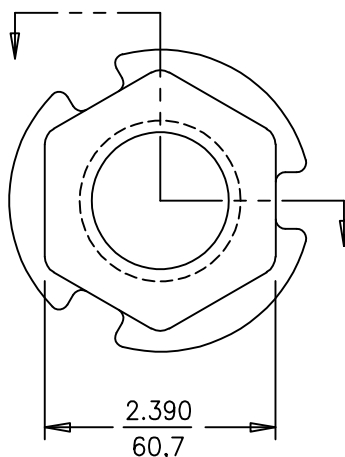

DIMENSIONS: INCH/mm mm FOR REFERENCE ONLY		QUALITY PLAN NUMBER: QBE0020100F		TOLERANCES: ±.035 UNLESS NOTED	WEIGHT 3.2 LBS.	REV.	DATE	NAME	PART NUMBER: B36E24210	
1-3/8" GROUTABLE ANCHOR NUTS FOR THREADBAR GR. 150				MATERIAL: C1045 FORGING ASTM A521-CF MOD. NORMALIZED BHN = 180-220	SCALE 1:2				DRAWING NUMBER: B36E24200	
				DATE: 06-07-05	DWG: G. MALECKI	CHK: H.K.	APP: K.S.			
THIS DRAWING, THE PERTINENT ENCLOSURES, DESCRIPTIONS, CALCULATIONS ETC. AND THEIR CONTENTS ARE THE PROPERTY OF DYWIDAG SYSTEMS INTERNATIONAL, USA, INC. THEY ARE NOT ALLOWED TO BE DUPLICATED WITHOUT OUR PERMISSION. THEY ARE ALSO NOT TO BE SHOWN OR EXPLAINED FOR ANY REASON TO A THIRD PARTY OTHER THAN FOR REASONS EXPRESSLY INTENDED BY DSI'S SUBMITTAL TO THE ORIGINAL RECEIVER. THEY HAVE TO BE RETURNED UPON REQUEST.				DYWIDAG-SYSTEMS INTERNATIONAL, USA, INC. 320 MARMON DRIVE - BOLINGBROOK, IL 60440 PHONE: 630-739-1100			FAX: 630-739-1405			DYWIDAG

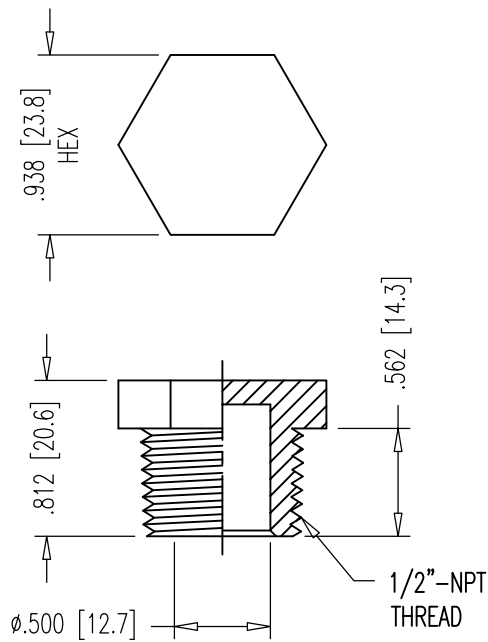

PRESSURE RATED: 150 PSI

DIMENSIONS: INCH [mm] mm FOR REFERENCE ONLY		QUALITY PLAN NUMBER:		WEIGHT .006 LBS.	REV.	DATE	NAME	ECRN	PART NUMBER: 00 00 649
1/2" NPT NYLON PLUG									
				DATE: 03-12-19	DWG: G. MALECKI	CHK: S.I.	APP: S.I.	MATERIAL: NYLON 6 COLOR: WHITE	
THIS DRAWING, THE PERTINENT ENCLOSURES, DESCRIPTIONS, CALCULATIONS ETC. AND THEIR CONTENTS ARE THE PROPERTY OF DYWIDAG SYSTEMS INTERNATIONAL, USA, INC. THEY ARE NOT ALLOWED TO BE DUPLICATED WITHOUT OUR PERMISSION. THEY ARE ALSO NOT TO BE SHOWN OR EXPLAINED FOR ANY REASON TO A THIRD PARTY OTHER THAN FOR REASONS EXPRESSLY INTENDED BY DSI's SUBMITTAL TO THE ORIGINAL RECEIVER. THEY HAVE TO BE RETURNED UPON REQUEST.				DYWIDAG-SYSTEMS INTERNATIONAL, USA, INC. 320 MARMON DRIVE - BOLINGBROOK, IL 60440 PHONE: 630-739-1100 FAX: 630-739-1405					

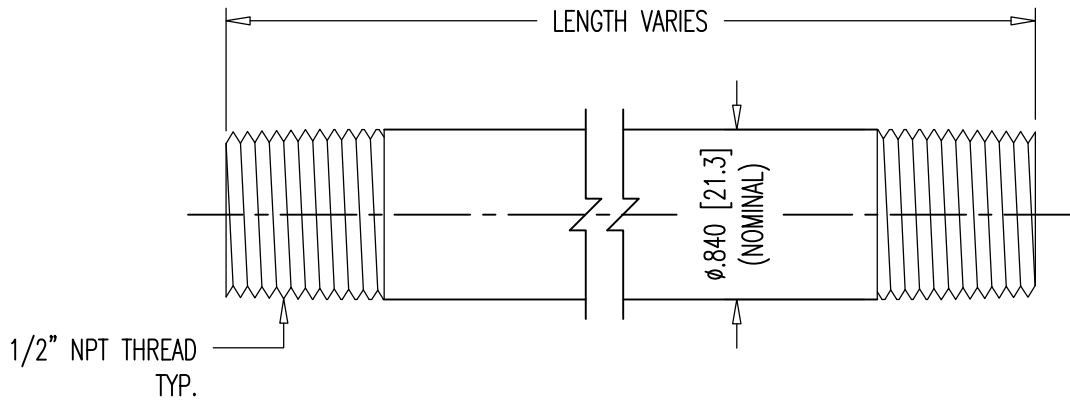

PRESSURE RATED: 150 PSI

DIMENSIONS: INCH [mm] mm FOR REFERENCE ONLY		QUALITY PLAN NUMBER: Q000000020P		REV.	DATE	NAME	PART NUMBER: 00 00 678
1/2" NPT PIPE NIPPLES				MATERIAL: SCH 40 BLACK WELDED STEEL	SCALE 1:1		DRAWING NUMBER: 00 00 678
DATE: 01-29-19	DWG: G. MALECKI	CHK: S.I.	APP: S.I.	DYWIDAG-SYSTEMS INTERNATIONAL, USA, INC. 320 MARMON DRIVE - BOLINGBROOK, IL 60440 PHONE: 630-739-1100 FAX: 630-739-1405			
THIS DRAWING, THE PERTINENT ENCLOSURES, DESCRIPTIONS, CALCULATIONS ETC. AND THEIR CONTENTS ARE THE PROPERTY OF DYWIDAG SYSTEMS INTERNATIONAL, USA, INC. THEY ARE NOT ALLOWED TO BE DUPLICATED WITHOUT OUR PERMISSION. THEY ARE ALSO NOT TO BE SHOWN OR EXPLAINED FOR ANY REASON TO A THIRD PARTY OTHER THAN FOR REASONS EXPRESSLY INTENDED BY DSI's SUBMITTAL TO THE ORIGINAL RECEIVER. THEY HAVE TO BE RETURNED UPON REQUEST.				DYWIDAG 			

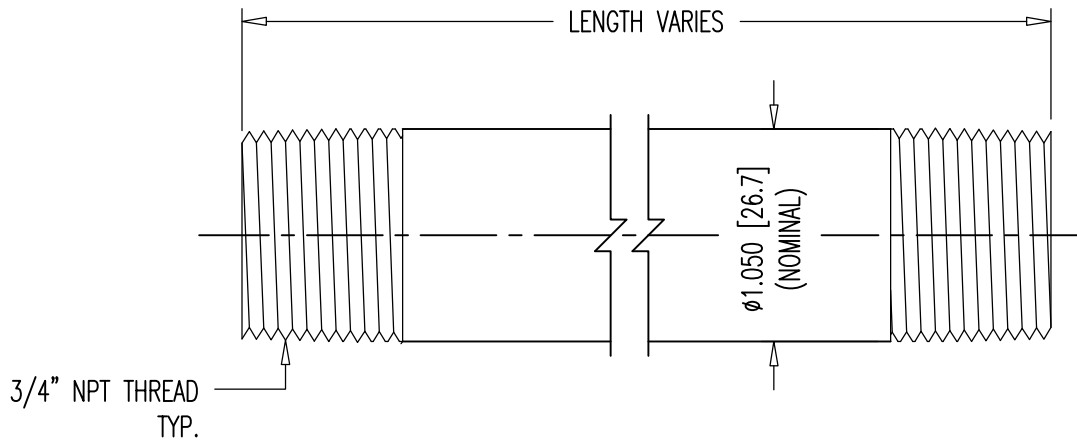

PRESSURE RATED: 150 PSI

DIMENSIONS: INCH [mm] mm FOR REFERENCE ONLY		QUALITY PLAN NUMBER: Q00000020P		REV.	DATE	NAME	ECRN	PART NUMBER: 00 00 878	
3/4" NPT PIPE NIPPLES				MATERIAL:	SCALE				
				SCH 40 BLACK WELDED STEEL		1:1			DRAWING NUMBER: 00 00 878
DATE: 01-29-19	DWG: G. MALECKI	CHK: S.I.	APP: S.I.						
THIS DRAWING, THE PERTINENT ENCLOSURES, DESCRIPTIONS, CALCULATIONS ETC. AND THEIR CONTENTS ARE THE PROPERTY OF DYWIDAG SYSTEMS INTERNATIONAL, USA, INC. THEY ARE NOT ALLOWED TO BE DUPLICATED WITHOUT OUR PERMISSION. THEY ARE ALSO NOT TO BE SHOWN OR EXPLAINED FOR ANY REASON TO A THIRD PARTY OTHER THAN FOR REASONS EXPRESSLY INTENDED BY DSI's SUBMITTAL TO THE ORIGINAL RECEIVER. THEY HAVE TO BE RETURNED UPON REQUEST.				DYWIDAG-SYSTEMS INTERNATIONAL, USA, INC. 320 MARMON DRIVE - BOLINGBROOK, IL 60440 PHONE: 630-739-1100 FAX: 630-739-1405				DYWIDAG 	

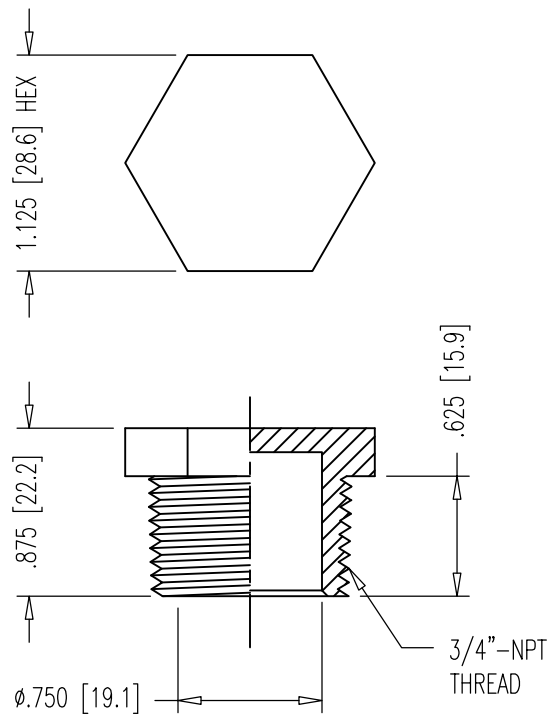

PRESSURE RATED: 150 PSI

DIMENSIONS: INCH [mm] mm FOR REFERENCE ONLY		QUALITY PLAN NUMBER:		WEIGHT .009 LBS.	REV.	DATE	NAME	PART NUMBER: 00 00 849
3/4" NPT NYLON PLUG								
				DATE: 03-12-19	DWG: G. MALECKI	CHK: S.I.	APP: S.I..	DYWIDAG-SYSTEMS INTERNATIONAL, USA, INC. 320 MARMON DRIVE - BOLINGBROOK, IL 60440 PHONE: 630-739-1100 FAX: 630-739-1405
THIS DRAWING, THE PERTINENT ENCLOSURES, DESCRIPTIONS, CALCULATIONS ETC. AND THEIR CONTENTS ARE THE PROPERTY OF DYWIDAG SYSTEMS INTERNATIONAL, USA, INC. THEY ARE NOT ALLOWED TO BE DUPLICATED WITHOUT OUR PERMISSION. THEY ARE ALSO NOT TO BE SHOWN OR EXPLAINED FOR ANY REASON TO A THIRD PARTY OTHER THAN FOR REASONS EXPRESSLY INTENDED BY DSI's SUBMITTAL TO THE ORIGINAL RECEIVER. THEY HAVE TO BE RETURNED UPON REQUEST.								

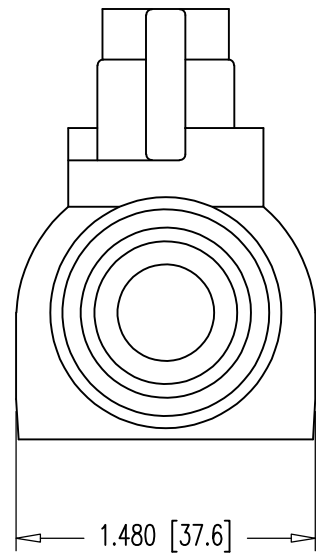
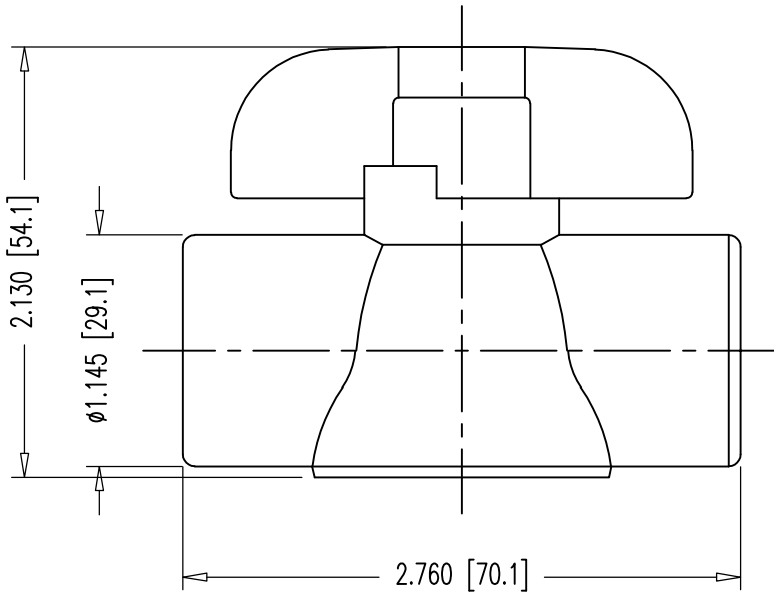
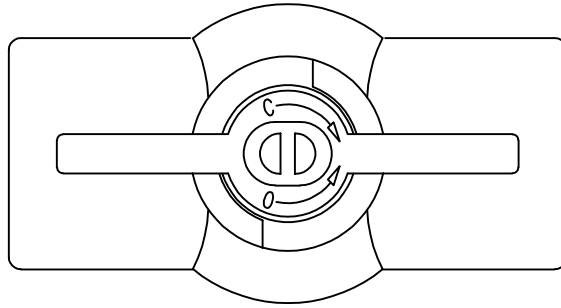

⚠ NOTE:
PRESSURE RATED: 150 PSI.

DIMENSIONS: INCH [mm] mm FOR REFERENCE ONLY		QUALITY PLAN NUMBER:		WEIGHT 0.138 LBS.	REV.	DATE	NAME	PART NUMBER: 00 00 634
1/2" NPT BALL VALVE					1	01-11-19	S.I.	
				MATERIAL: PVC	SCALE 1:1			
DATE: 04-30-07	DWG: G. MALECKI	CHK: S.N.	APP: E.A.					
THIS DRAWING, THE PERTINENT ENCLOSURES, DESCRIPTIONS, CALCULATIONS ETC. AND THEIR CONTENTS ARE THE PROPERTY OF DYWIDAG SYSTEMS INTERNATIONAL, USA, INC. THEY ARE NOT ALLOWED TO BE DUPLICATED WITHOUT OUR PERMISSION. THEY ARE ALSO NOT TO BE SHOWN OR EXPLAINED FOR ANY REASON TO A THIRD PARTY OTHER THAN FOR REASONS EXPRESSLY INTENDED BY DSI'S SUBMITTAL TO THE ORIGINAL RECEIVER. THEY HAVE TO BE RETURNED UPON REQUEST.				DYWIDAG-SYSTEMS INTERNATIONAL, USA, INC. 320 MARMON DRIVE - BOLINGBROOK, IL 60440 PHONE: 630-739-1100			DYWIDAG	
				FAX: 630-739-1405				

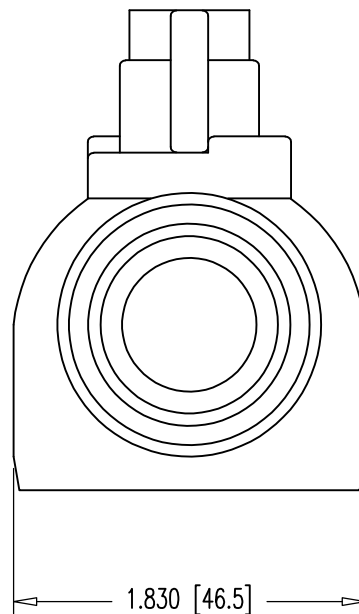
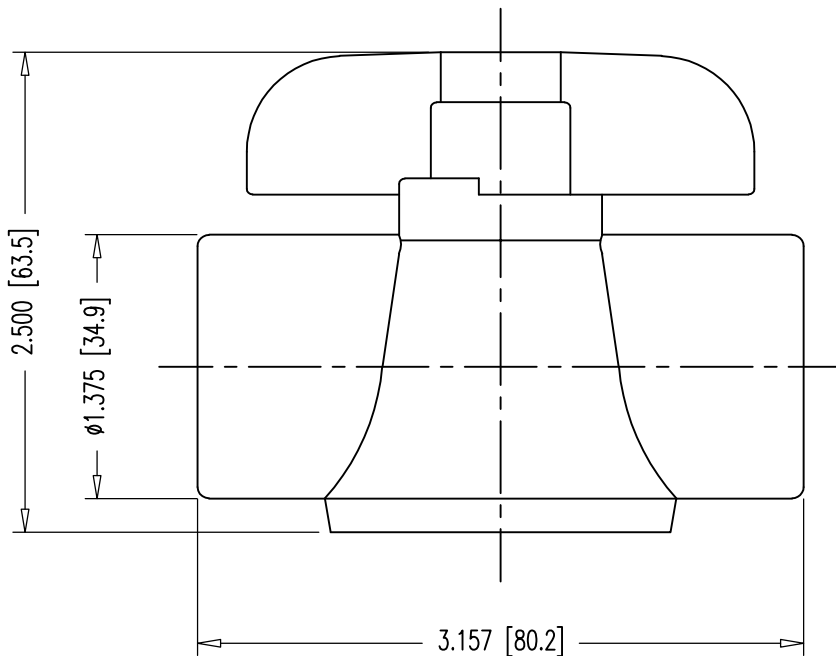
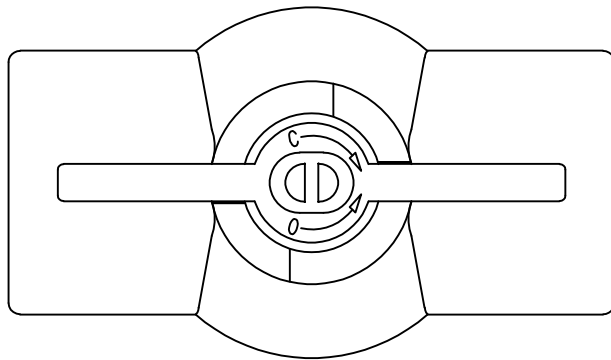

▲ NOTE:
PRESSURE RATED: 150 PSI.

DIMENSIONS: INCH [mm] mm FOR REFERENCE ONLY		QUALITY PLAN NUMBER:		WEIGHT 0.213 LBS.	REV.	DATE	NAME	PART NUMBER: 00 00 834	
3/4" NPT BALL VALVE		MATERIAL: PVC			1	01-11-19	S.I.		
				DATE: 04-30-07		DWG: G. MALECKI		CHK: S.N.	
THIS DRAWING, THE PERTINENT ENCLOSURES, DESCRIPTIONS, CALCULATIONS ETC. AND THEIR CONTENTS ARE THE PROPERTY OF DYWIDAG SYSTEMS INTERNATIONAL, USA, INC. THEY ARE NOT ALLOWED TO BE DUPLICATED WITHOUT OUR PERMISSION. THEY ARE ALSO NOT TO BE SHOWN OR EXPLAINED FOR ANY REASON TO A THIRD PARTY OTHER THAN FOR REASONS EXPRESSLY INTENDED BY DSI's SUBMITTAL TO THE ORIGINAL RECEIVER. THEY HAVE TO BE RETURNED UPON REQUEST.				DYWIDAG-SYSTEMS INTERNATIONAL, USA, INC. 320 MARMON DRIVE - BOLINGBROOK, IL 60440 PHONE: 630-739-1100 FAX: 630-739-1405				DYWIDAG	

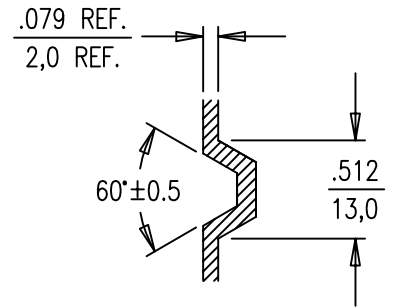
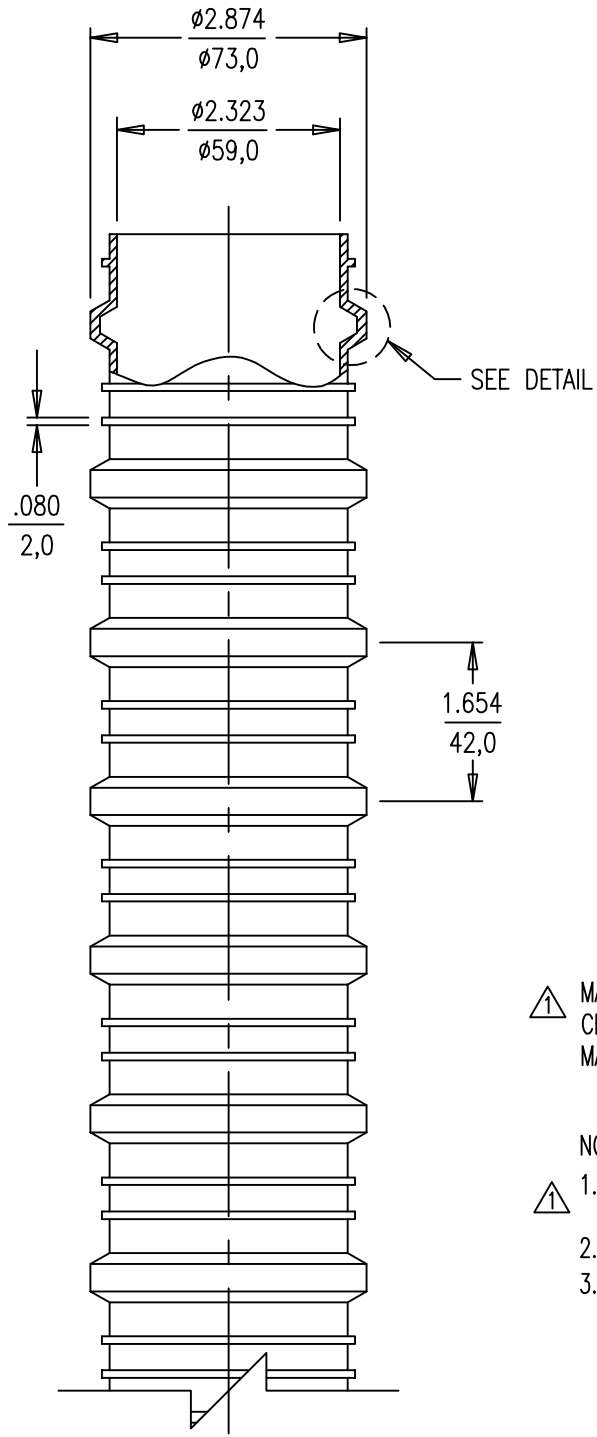

DETAIL
SCALE 1:1

▲ MATERIAL: POLYPROPYLENE
 CELL CLASS RANGE: PP0340B44541 TO PP0340B67884
 MATERIAL MEETS FDOT SPECS. 960-2.4.3.

NOTES:

- ▲ 1. STANDARD FIT FOR 5-0.6", 7-0.5", 7-0.6" & 9-0.5" STRANDS AND 1", 1-1/4", & 1-3/8" THREADBARS.
- 2. Min. BENDING RADIUS, Rmin = 22.8 FT.
- 3. DUCT IS DELIVERED IN STRAIGHT SECTIONS AND IS NOT INTENDED TO BE COILED.

DIMENSIONS: INCH [mm] mm FOR REFERENCE ONLY		QUALITY PLAN NUMBER: QU00041110P		TOLERANCES: ±.020 UNLESS NOTED	WEIGHT 0.296 LBS/FT	REV. 1	DATE 01-11-19	NAME S.I.	PART NUMBER: U00220200
2-3/8" (59mm) CORRUGATED PP DUCT				MATERIAL: SEE ABOVE	SCALE 1:2				DRAWING NUMBER: U00220200
DATE: 04-23-96	DWG: G. MALECKI	CHK: H.K.	APP: K.S.						
<small>THIS DRAWING, THE PERTINENT ENCLOSURES, DESCRIPTIONS, CALCULATIONS ETC. AND THEIR CONTENTS ARE THE PROPERTY OF DYWIDAG SYSTEMS INTERNATIONAL, USA, INC. THEY ARE NOT ALLOWED TO BE DUPLICATED WITHOUT OUR PERMISSION. THEY ARE ALSO NOT TO BE SHOWN OR EXPLAINED FOR ANY REASON TO A THIRD PARTY OTHER THAN FOR REASONS EXPRESSLY INTENDED BY DSI'S SUBMITTAL TO THE ORIGINAL RECEIVER. THEY HAVE TO BE RETURNED UPON REQUEST.</small>				DYWIDAG-SYSTEMS INTERNATIONAL, USA, INC. POST TENSIONING / REINFORCING UNIT PHONE: 630-739-1100 320 MARMON DRIVE - BOLINGBROOK, IL FAX: 630-739-1405					

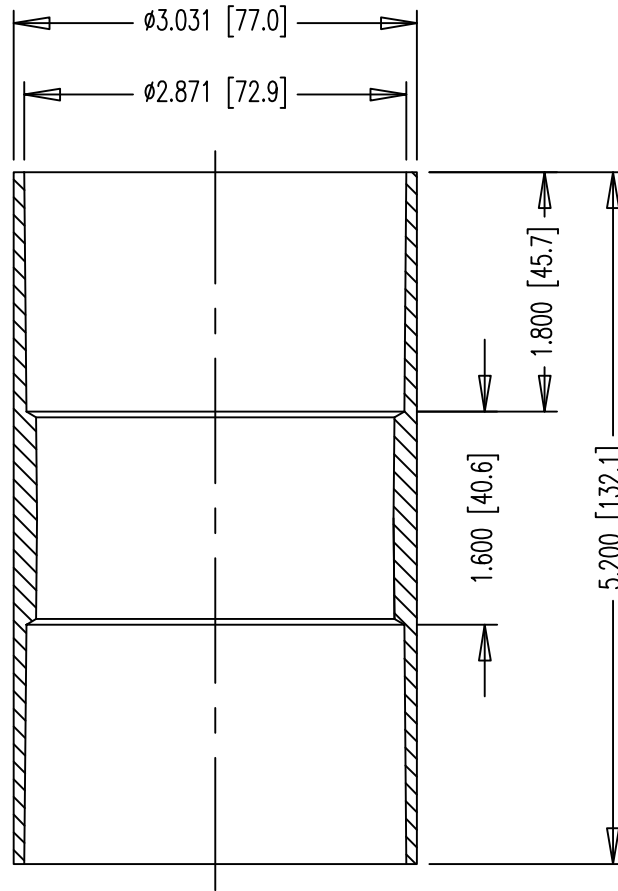
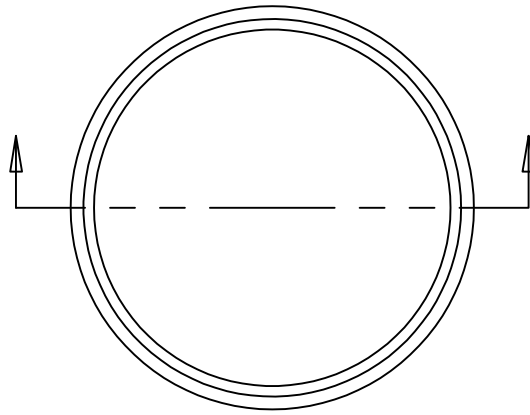

▲ MATERIAL: POLYPROPYLENE
 CELL CLASS RANGE: PP0340B44541 TO PP0340B67884
 MATERIAL MEETS FDOT SPECS. 960-2.4.3.

DIMENSIONS: INCH [mm] mm FOR REFERENCE ONLY		QUALITY PLAN NUMBER: QSA0028000P		TOLERANCES: ±.005 UNLESS NOTED	WEIGHT 0.23 LBS.	REV. 1	DATE 01-11-19	NAME S.I.	PART NUMBER: U00220205
Ø2-3/8" (59mm) DUCT COUPLER				MATERIAL: SEE ABOVE	SCALE 2:3				DRAWING NUMBER: U00220205
				DATE: 10-25-99	DWG: G. MALECKI	CHK: S.Y.	APP: K.S.		

THIS DRAWING, THE PERTINENT ENCLOSURES, DESCRIPTIONS, CALCULATIONS ETC.
 AND THEIR CONTENTS ARE THE PROPERTY OF **DYWIDAG SYSTEMS INTERNATIONAL,
 USA, INC.** THEY ARE NOT ALLOWED TO BE DUPLICATED WITHOUT OUR PERMISSION.
 THEY ARE ALSO NOT TO BE SHOWN OR EXPLAINED FOR ANY REASON TO A THIRD
 PARTY OTHER THAN FOR REASONS EXPRESSLY INTENDED BY DSI'S SUBMITTAL TO
 THE ORIGINAL RECEIVER. THEY HAVE TO BE RETURNED UPON REQUEST.

DYWIDAG-SYSTEMS INTERNATIONAL, USA, INC.
 320 MARMON DRIVE - BOLINGBROOK, IL 60440
 PHONE: 630-739-1100 FAX: 630-739-1405



DIMENSIONS & ORDERING INFO	P	L	A	-	XXX	-	YYY	-	ZZ	STANDARD ORDERING OPTIONS
										YE - YELLOW, BK - BLACK
										300mm, 450mm, 600mm, 900mm (12", 18", 24", 36")
										63mm -315mm (2-1/2" - 12")
										A - 0.75 mm (30 mils)
										L - 0.80 mm (31 mils)
										P - Tubular

TUBULAR SLEEVE	TUBULAR SLEEVE DIAMETER AS SUPPLIED	TUBULAR SLEEVE DIAMETER FULLY RECOVERED
PLA 63-YYY YE	3.5" [90mm]	2.5" [63mm]
PLA 90-YYY YE	4.8" [120mm]	3.3" [81mm]
PLA 115-YYY BK	5.5" [145mm]	3.8" [98mm]
PLA 125-YYY YE	6.3" [160mm]	4.3" [110mm]
PLA 160-YYY BK	7.5" [190mm]	5.2" [130mm]
⚠ PMA 90/30-YYY BK	3.5" [90mm]	1.2" [30mm]
⚠ PMA 120/40-YYY BK	4.7" [120mm]	1.6" [40mm]

YYY = SLEEVE WIDTH: 300/450/600/900/1500(mm)
 COLOR: YE = YELLOW; BK = BLACK

PMA - HIGH SHRINK SLEEVE.
 HIGH SHRINK TUBULAR BACKING.

MATERIAL:
 ACCORDING TO FDOT SPECIFICATION
 POST TENSIONING, SECTION 462 - 4, 2, 6, 3.

- NOTES:**
- ORDER DIRECT FROM CANUSA
 TEL. 281 367 - 8866
 FAX. 281 367 - 4304
 - SELECT ORDER LENGTH AS A MULTIPLE OF THE ACTUAL LENGTH.
 - OTHER COLORS SLEEVE MAY BE AVAILABLE UPON REQUEST.
 - ALWAYS HEAT THE DUCT ENDS FIRST.

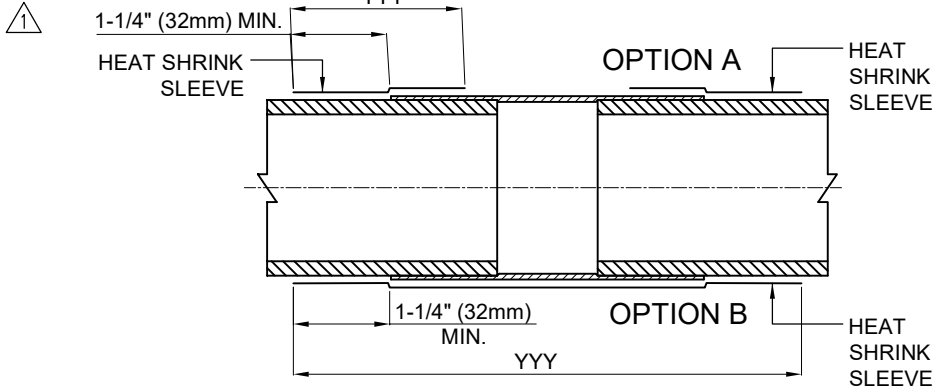

NOTE:
 FOLLOW MANUFACTURER'S
 INSTALLATION INSTRUCTIONS.

	DUCT SIZE ⚠	STRAND SYSTEM	BAR SYSTEM	HEAT SHRINK SLEEVE SIZE	PART NUMBER
CORRUGATED DUCT	1" x 3" (25mm x 76mm)	4-0.6"		PLA-63-450 YE	U00044063
	2-3/8" (59mm)	7-0.6"		PLA-63-450 YE	U00044063
				1", 1-1/4", 1-3/8"	PMA-90/30-450 BK ⚠
	3" (76mm)		1 3/4"	⚠ PMA-120/40-450 BK	⚠ U00044040
	3-3/8" (85mm)	12-0.6"		PLA-90-450 YE	U00044090
	4" (100mm)		2-1/2"	PLA-90-450 YE	U00044090
	4" (100mm)	19-0.6"		PLA-115-450 BK	U00044115
	4-1/2" (115mm)	27-0.6"		PLA-125-450 YE	U00044125
5-1/8" (130mm)	31-0.6", 37-0.6"		PLA-160-450 BK	U00044160	
⚠ SMOOTH DUCT	3" SDR 17 HDPE PIPE		1-3/8"	PLA-63-450 YE	U00044063

DIMENSIONS: INCH [mm] mm FOR REFERENCE ONLY				REV.				DATE				NAME				ECRN				PART NUMBERS:							
HEAT SHRINK SLEEVE SIZES FOR INTERNAL GROUTED APPLICATIONS												⚠				05-28-20				S.I.				SEE TABLE ABOVE			
												SCALE															
DATE: 07-31-19				DWG: G. Malecki				CHK: S.I.				APP: S.I.				DRAWING NUMBER: U00044000											
THIS DRAWING, THE PERTINENT ENCLOSURES, DESCRIPTIONS, CALCULATIONS ETC. AND THEIR CONTENTS ARE THE PROPERTY OF DYWIDAG SYSTEMS INTERNATIONAL, USA, INC. THEY ARE NOT ALLOWED TO BE DUPLICATED WITHOUT OUR PERMISSION. THEY ARE ALSO NOT TO BE SHOWN OR EXPLAINED FOR ANY REASON TO A THIRD PARTY OTHER THAN FOR REASONS EXPRESSLY INTENDED BY DSI's SUBMITTAL TO THE ORIGINAL RECEIVER. THEY HAVE TO BE RETURNED UPON REQUEST.																											
DYWIDAG-SYSTEMS INTERNATIONAL, USA, INC. 320 MARMON DRIVE - BOLINGBROOK, IL 60440 PHONE: 630-739-1100 FAX: 630-739-1405																											

