



## Florida Department of Transportation

CHARLIE CRIST  
GOVERNOR

605 Suwannee Street  
Tallahassee, FL 32399-0450

STEPHANIE C. KOPELOUSOS  
SECRETARY

### **STRUCTURES DESIGN BULLETIN C10-06**

DATE: July 13, 2010

TO: District Directors of Production, District Design Engineers, District Structures Design Engineers, District Construction Engineers

FROM: Robert Robertson, P.E., State Structures Design Engineer 

COPIES: Brian Blanchard, Lora Hollingsworth, Jeffrey Ger (FHWA)

SUBJECT: Implementation of New Florida-I 84 and 96 Beam Design Standards Including Related Data Tables and Structures Manual Revisions

This Structures Design Bulletin (SDB) implements the 84 inch and 96 inch Florida-I Beam sizes, which were developed based on the guidelines for no end diaphragms per SDB C10-04 released in May 2010 and SDB C10-05 released in July 2010.

### **REQUIREMENTS**

#### **1. Design Standards**

The Florida-I Beam and related Design Standards Index Sheets have been released for implementation with the July 2010 Interim Design Standards. Copies of these sheets and their associated data tables are included with Attachment 'A' as listed below.

Attachment 'A', 84 inch and 96 inch Florida-I Beam Design Standards:

- a. Index No. 20084 (2 Sheets): Florida-I 84 Beam – Standard Details
- b. Index No. 20096 (2 Sheets): Florida-I 96 Beam – Standard Details

#### **2. Structures Manual Volume 1: Structures Design Guidelines**

- a. Insert the following girder costs into Section 9.2.2.B.2 (Prestressed Concrete Girders; cost per linear foot):  
Florida-I; 96 \$355
- b. Insert the following debris quantity estimations into Section 9.4 (Component; CY/LF):  
84" Florida-I 0.294  
96" Florida-I 0.315

### 3. Structures Manual Volume 3: Instructions for Structures Related Design Standards

- a. Index 20010 Series Prestressed Florida-I Beams: Change the first paragraph under ‘Design Assumptions and Limitations’ as follows:  
Index 20010 is the lead standard for the Prestressed Florida-I Beam standard series which includes Indexes 20010 through ~~20078~~20096. Use this standard with Indexes 20005, 20036, 20045, 20054, 20063, 20072, 20078, 20084, 20096, 20199, 20510, and 20511 and 20512.
- b. Index 20010 Series Prestressed Florida-I Beams: Add the following two rows to the table in ‘Design Assumptions and Limitations’:

Index No.	Beam Type	Max. Bonded Prestress Force	Last Revision Date
20084	Florida-I 84	2375 Kips	07/01/10
20096	Florida-I 96	2375 Kips	07/01/10

- c. Index 20010 Series Prestressed Florida-I Beams: Add the following as the second to last paragraph in ‘Design Assumptions and Limitations’:  
Prestressed Beam Suppliers typically utilize side forms for casting which are not easily or economically modified. If modifications to beam cross-sections are required for any reason other than haunched sections, maintain profile dimensions of the form. For example: To thicken the web, increase the spacing between side forms. To increase the beam height, vary the thickness of the top or bottom flange. In any case, do not reduce the standard thickness of either the top or bottom flange.
- d. Index 20010 Series Prestressed Florida-I Beams: Add Attachment B: (Charts of Maximum Beam Span vs. Spacing) under the heading of ‘Design Aid’
- e. Index 20010 Series Prestressed Florida-I Beams: Add Attachment C: (Florida-I Beam Section Properties) along with the previously released section properties of the FIB 36 thru 78 beams under the heading of ‘Section Properties’

### **BACKGROUND**

The 84 and 96 inch tall Florida-I beams are released as a follow up to the shorter Florida-I Beams. These new beams have similar top and bottom flange dimensions, but the additional height allows for greater span lengths than achievable before with prestressed concrete I-girders. The maximum span for the FIB 84 beam is 191 feet, and the maximum span for the FIB 96 beam is 208 feet.

### **IMPLEMENTATION**

The Florida-I 84 Beam and Florida-I 96 Beam Design Standards are effective with the July 2010 Design Standards.

No currently designed projects will require a redesign as a result of this SDB, but Districts may elect to introduce these new beams into current designs at their discretion.

New BDR’s shall continue to consider the use of all viable structure types including the possibility of steel box and/or I-girders. Current policies stated in the Plans Preparation Manual Vol. 1 Section 26.9 still apply.

FIB 84 and 96 beams may be used on Design-Build projects effective immediately.

Current policies regarding the shipping of large girders remain in effect for FIB's. Allowable size limits for beams are limited to project-specific transportation considerations. As stated in Structures Design Guidelines Section 4.1.3, the transportation of heavy and/or long girders requires coordination with the Department's Permit Office and the appropriate industry representative during the design phase of the project.

**CONTACT**

Sam Fallaha, P.E.  
Assistant State Structures Design Engineer  
Phone: (850) 414-4296, Fax: (850) 414-4955  
E-mail: Sam.Fallaha@dot.state.fl.us

ARCHIVED

**ATTACHMENT A**

ARCHIVED

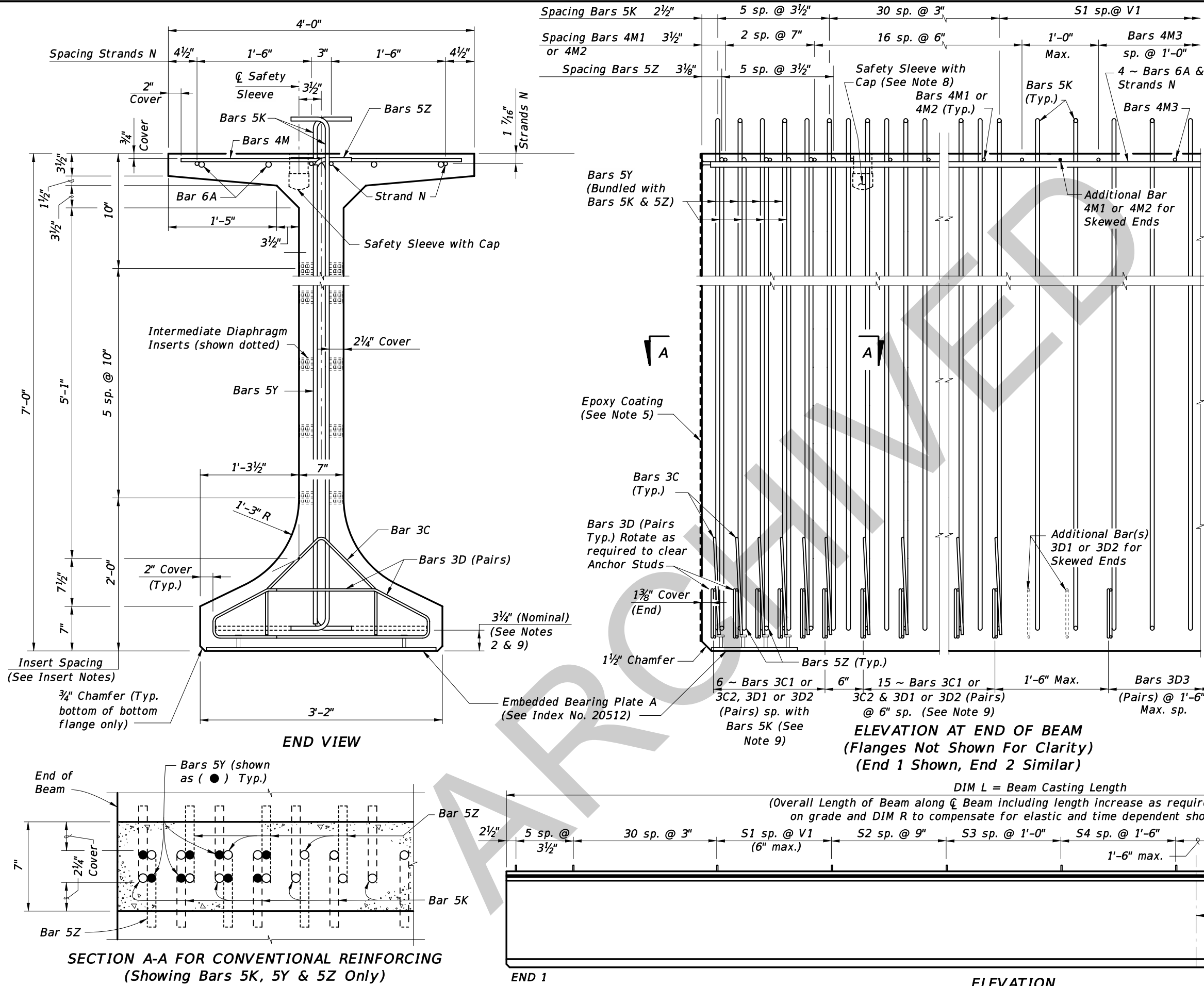

**CONVENTIONAL REINFORCING BAR BENDING DETAILS**

**BILL OF REINFORCING STEEL**

MARK	NOTE NUMBERS	SIZE	NUMBER REQUIRED	LENGTH (NOTE 1)
A	—	6	8	29'-0"
C1	9, 10 & 11	3	21 (End 1)	Varies
C2	9, 10 & 11	3	21 (End 2)	Varies
D1	9, 10, 11 & 14	3	42 (End 1)	Varies
D2	9, 10, 11 & 14	3	42 (End 2)	Varies
D3	9 & 14	3	See Table	4'-3"
K	2, 9, 11 & 13	5	See Table	8'-2"
M1	9 & 10	4	19 (End 1)	Varies
M2	9 & 10	4	19 (End 2)	Varies
M3	9	4	See Table	3'-8"
N	3 & 4	1/2" Ø Strand	4	DIM L
Y	9 & 11	5	16	6'-6"
Z	2, 9, 11 & 13	5	12	7'-8"

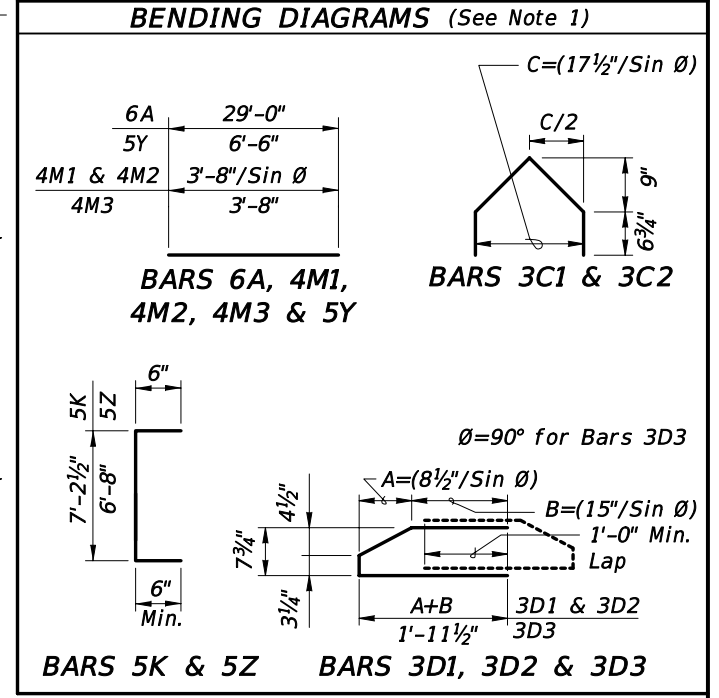

**NOTES:**

A. Work this Index with Index No. 20010 - Typical Florida-I Beam Details and Notes and the Florida-I Beam - Table of Beam Variables in Structures Plans.

B. For referenced notes, see Index No. 20010.

C. For Dimensions A, B, C, D, L, R & V1 and number of spaces S1 thru S4, see Florida-I Beam - Table of Beam Variables in Structures Plans.

**REVISIONS**

DATE	BY	DESCRIPTION	DATE	BY	DESCRIPTION
07/01/10	SJN	New Design Standard			

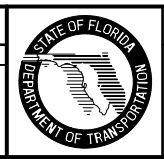

2010 Interim Design Standard

**FLORIDA-I 84 BEAM - STANDARD DETAILS**

Interim Date: 07/01/10

Sheet No.: 1 of 2

Index No.: **20084**

ALTERNATE REINFORCING STEEL (WELDED WIRE REINFORCEMENT) DETAILS

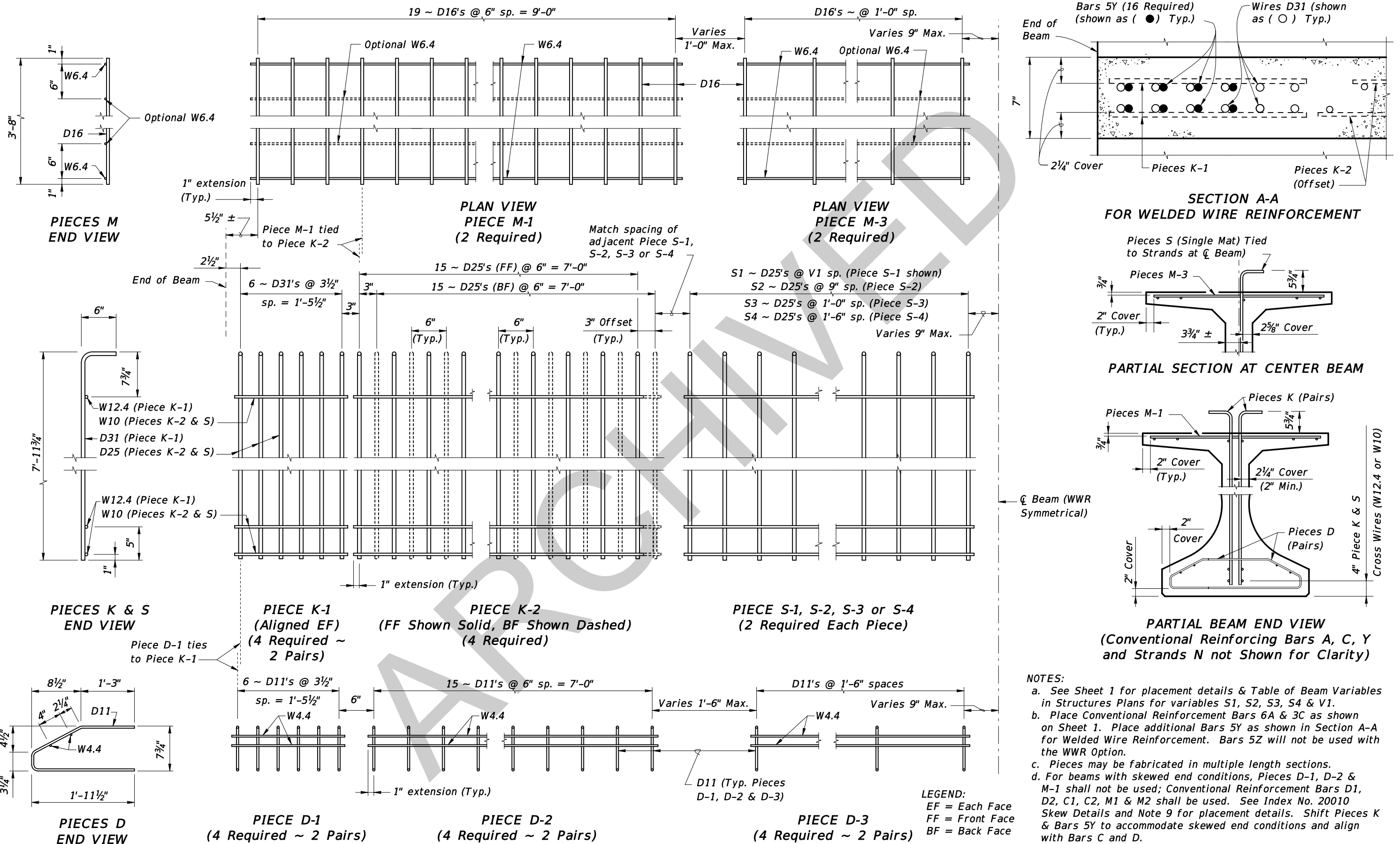

**NOTES:**

- See Sheet 1 for placement details & Table of Beam Variables in Structures Plans for variables S1, S2, S3, S4 & V1.
- Place Conventional Reinforcement Bars 6A & 3C as shown on Sheet 1. Place additional Bars 5Y as shown in Section A-A for Welded Wire Reinforcement. Bars 5Z will not be used with the WWR Option.
- Pieces may be fabricated in multiple length sections.
- For beams with skewed end conditions, Pieces D-1, D-2 & M-1 shall not be used; Conventional Reinforcement Bars D1, D2, C1, C2, M1 & M2 shall be used. See Index No. 20010 Skew Details and Note 9 for placement details. Shift Pieces K & Bars 5Y to accommodate skewed end conditions and align with Bars C and D.

REVISIONS

DATE	BY	DESCRIPTION	DATE	BY	DESCRIPTION
07/01/10	SJN	New Design Standard			

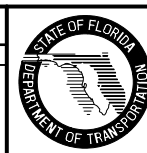

2010 Interim Design Standard

Interim Date: 07/01/10  
 Sheet No.: 2 of 2

FLORIDA-I 84 BEAM - STANDARD DETAILS

Index No. 20084

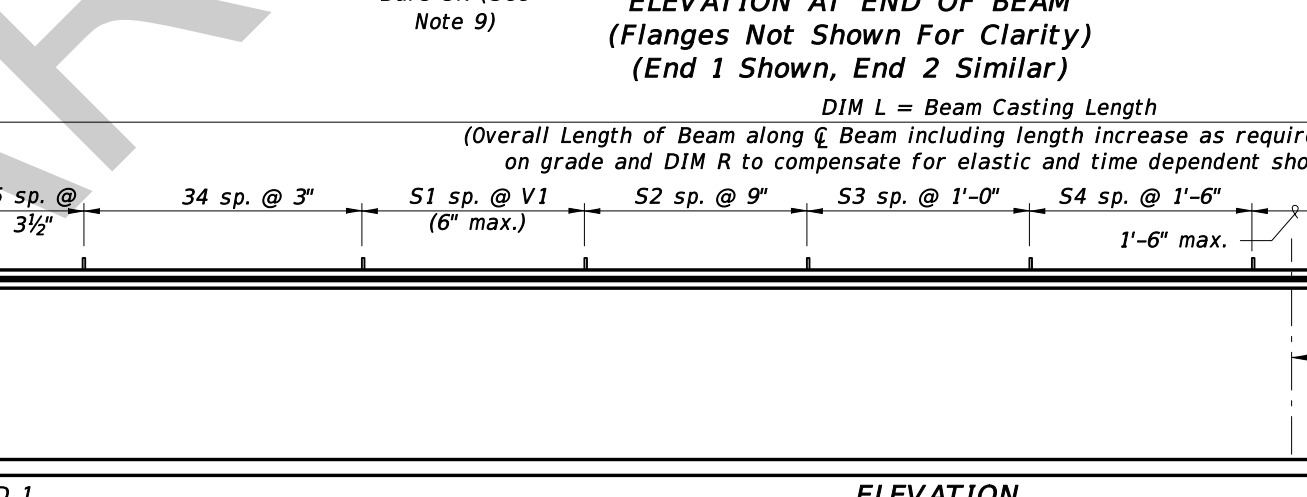
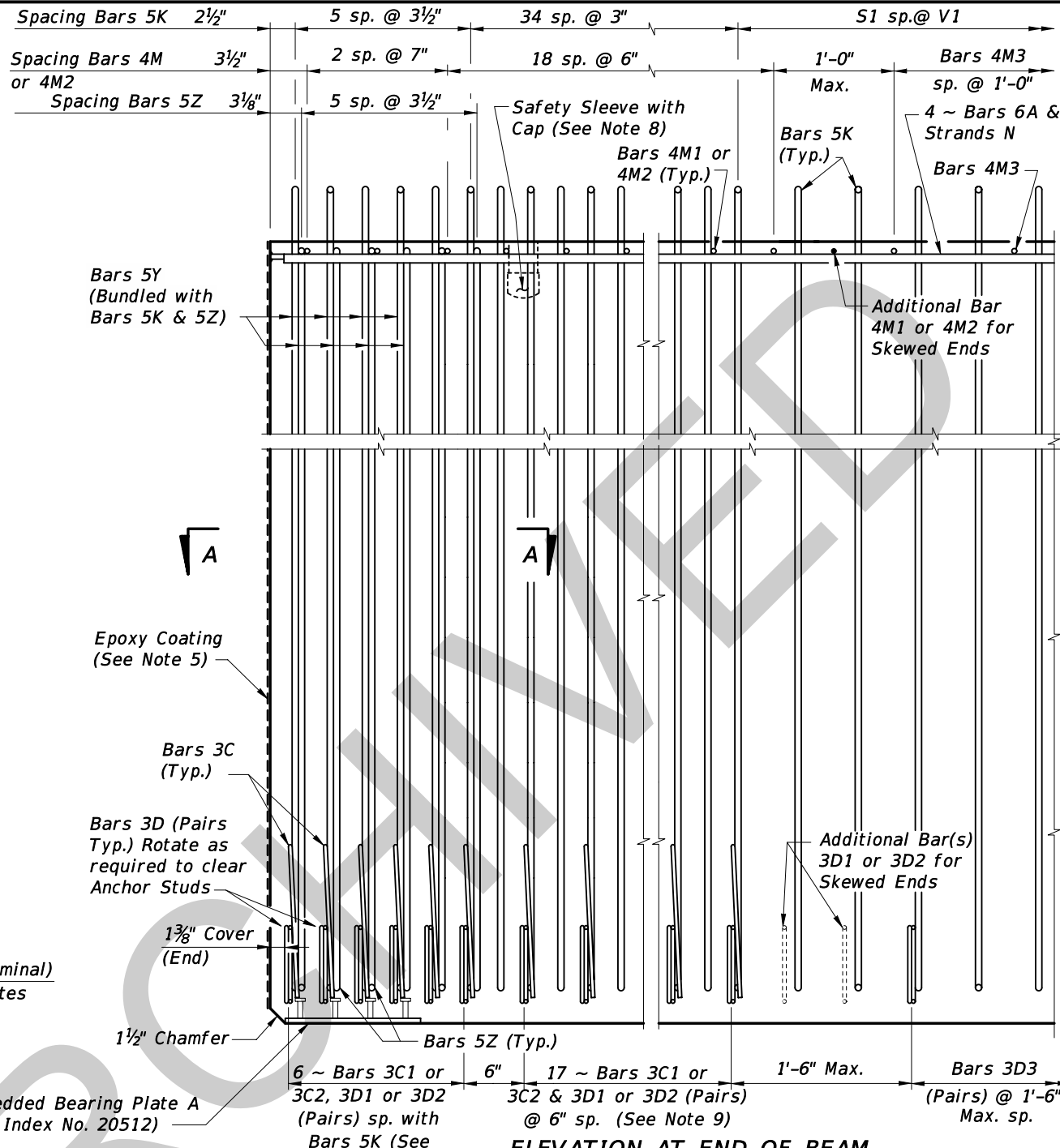
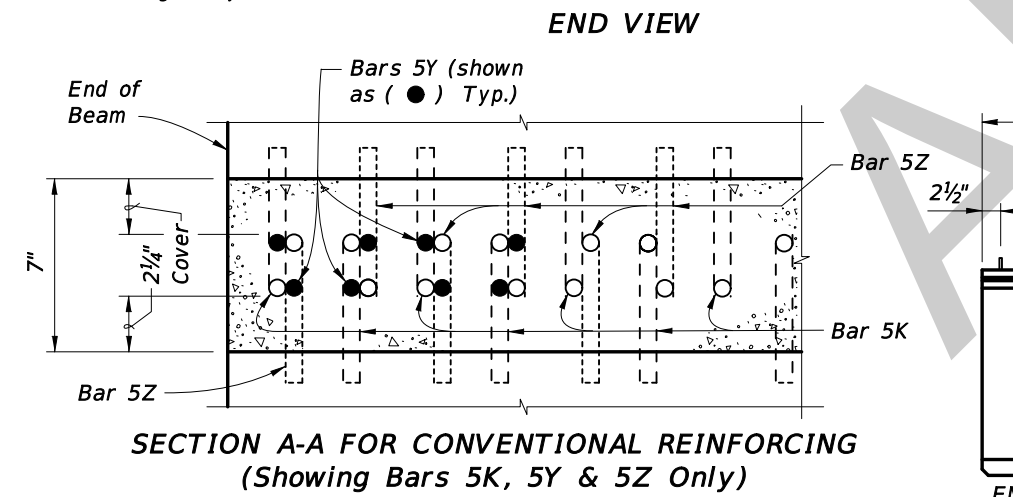
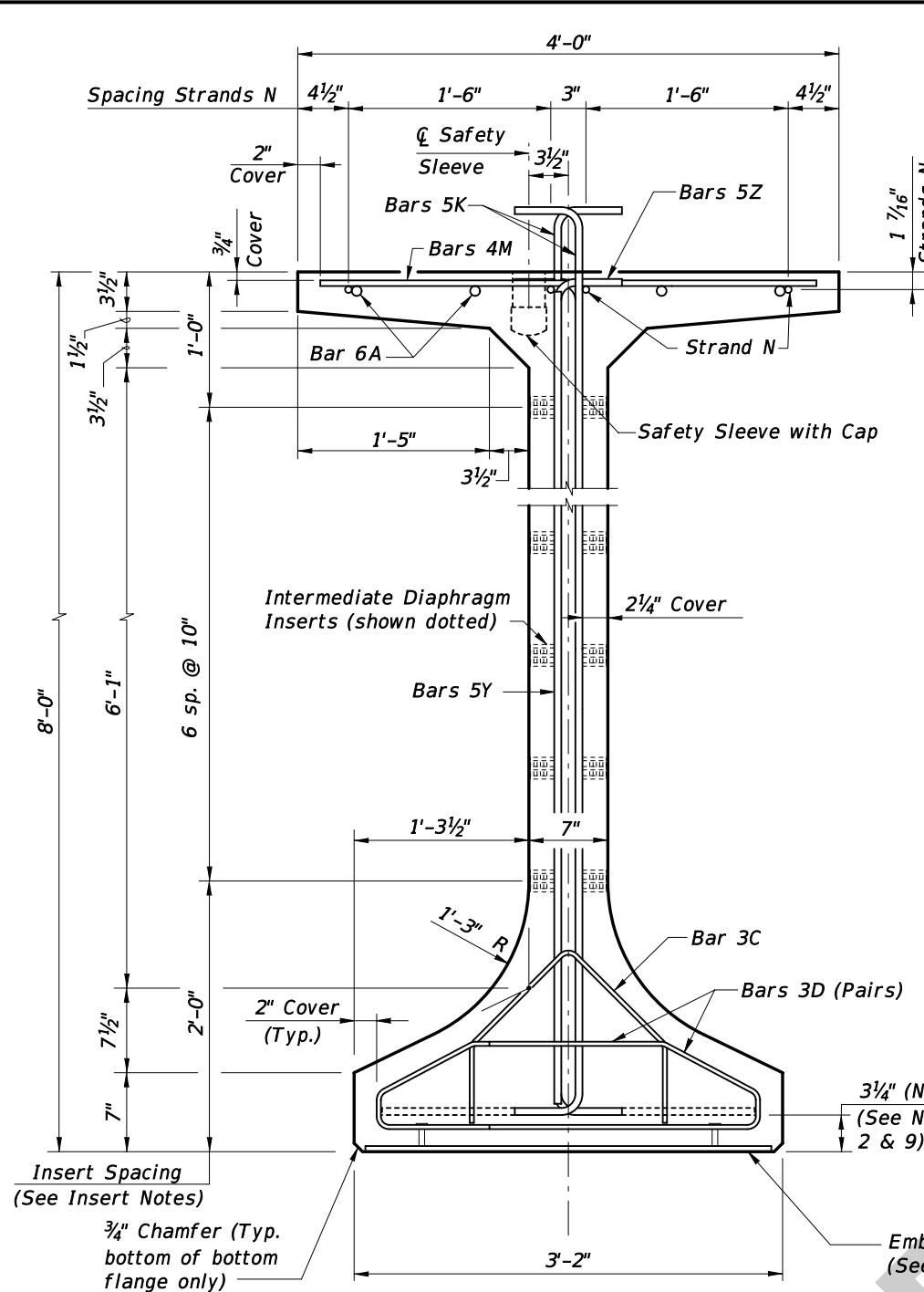

**CONVENTIONAL REINFORCING BAR BENDING DETAILS**

**BILL OF REINFORCING STEEL**

MARK	NOTE NUMBERS	SIZE	NUMBER REQUIRED	LENGTH (NOTE 1)
A	—	6	8	30'-0"
C1	9, 10 & 11	3	23 (End 1)	Varies
C2	9, 10 & 11	3	23 (End 2)	Varies
D1	9, 10, 11 & 14	3	46 (End 1)	Varies
D2	9, 10, 11 & 14	3	46 (End 2)	Varies
D3	9 & 14	3	See Table	4'-3"
K	2, 9, 11 & 13	5	See Table	9'-2"
M1	9 & 10	4	21 (End 1)	Varies
M2	9 & 10	4	21 (End 2)	Varies
M3	9	4	See Table	3'-8"
N	3 & 4	1/2" $\bar{\phi}$ Strand	4	DIM L
Y	9 & 11	5	16	
Z	2, 9, 11 & 13	5	12	

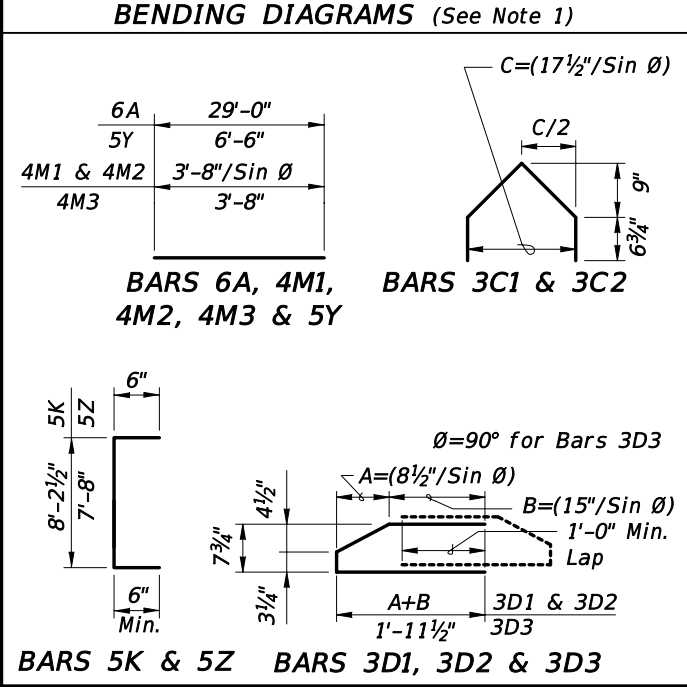

**NOTES:**

A. Work this Index with Index No. 20010 - Typical Florida-I Beam Details and Notes and the Florida-I Beam - Table of Beam Variables in Structures Plans.

B. For referenced notes, see Index No. 20010.

C. For Dimensions A, B, C, D, L, R & V1 and number of spaces S1 thru S4, see Florida-I Beam - Table of Beam Variables in Structures Plans.

**REVISIONS**

DATE	BY	DESCRIPTION	DATE	BY	DESCRIPTION
07/01/10	SJN	New Design Standard			

2010 Interim Design Standard

Interim Date 07/01/10 Sheet No. 1 of 2

Index No. 20096

FLORIDA-I 96 BEAM - STANDARD DETAILS

ALTERNATE REINFORCING STEEL (WELDED WIRE REINFORCEMENT) DETAILS

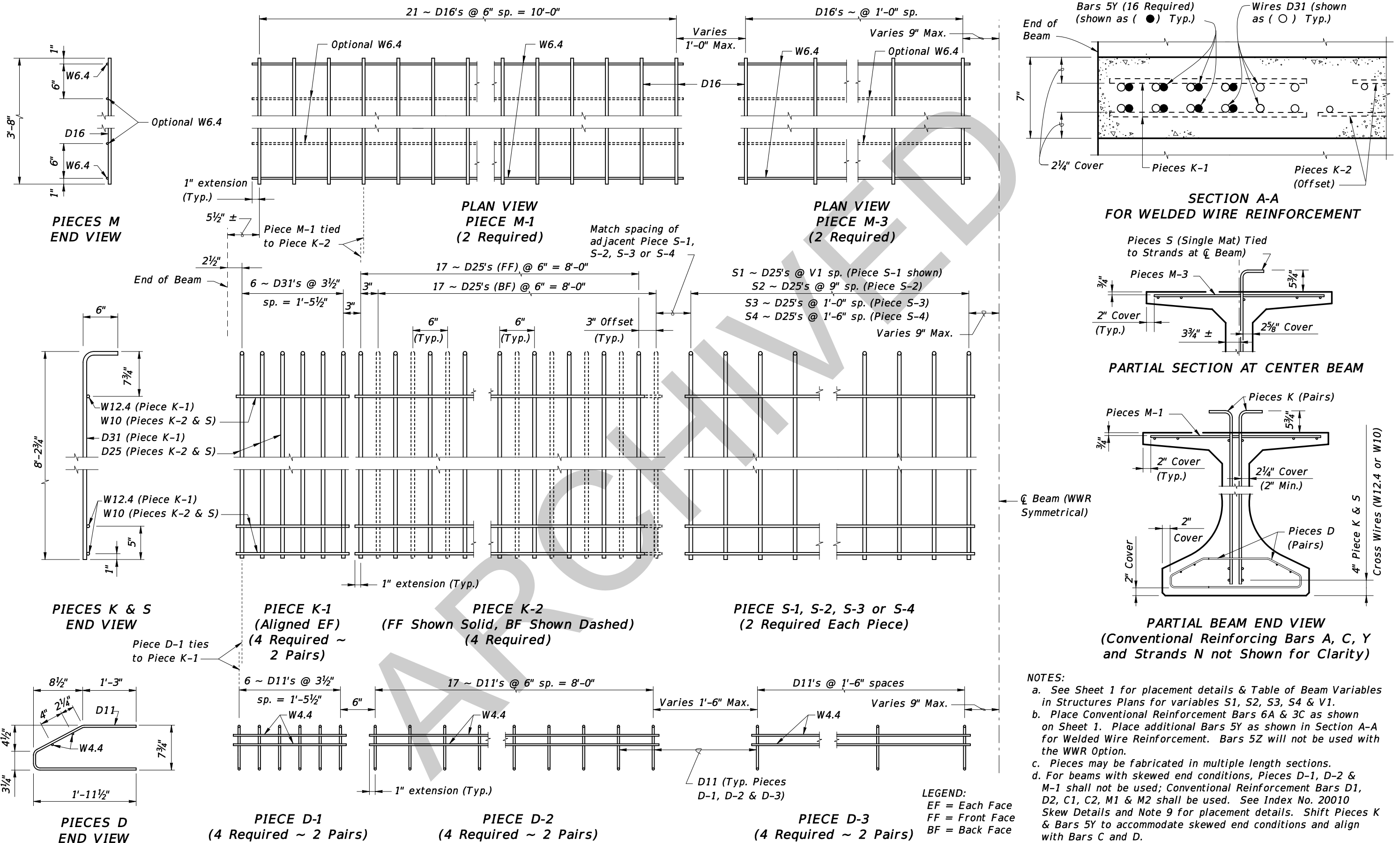

**NOTES:**

- See Sheet 1 for placement details & Table of Beam Variables in Structures Plans for variables S1, S2, S3, S4 & V1.
- Place Conventional Reinforcement Bars 6A & 3C as shown on Sheet 1. Place additional Bars 5Y as shown in Section A-A for Welded Wire Reinforcement. Bars 5Z will not be used with the WWR Option.
- Pieces may be fabricated in multiple length sections.
- For beams with skewed end conditions, Pieces D-1, D-2 & M-1 shall not be used; Conventional Reinforcement Bars D1, D2, C1, C2, M1 & M2 shall be used. See Index No. 20010 Skew Details and Note 9 for placement details. Shift Pieces K & Bars 5Y to accommodate skewed end conditions and align with Bars C and D.

**LEGEND:**  
 EF = Each Face  
 FF = Front Face  
 BF = Back Face

REVISIONS

DATE	BY	DESCRIPTION	DATE	BY	DESCRIPTION
07/01/10	SJN	New Design Standard			

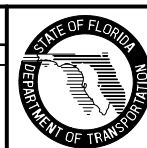

2010 Interim Design Standard

Interim Date: 07/01/10  
 Sheet No.: 2 of 2

FLORIDA-I 96 BEAM - STANDARD DETAILS

Index No. 20096



**ATTACHMENT B**

ARCHIVED

## Florida-I Beam Estimated Maximum Span Lengths

\*Moderately Aggressive Environment, FDOT Limits with 8.5 ksi Concrete

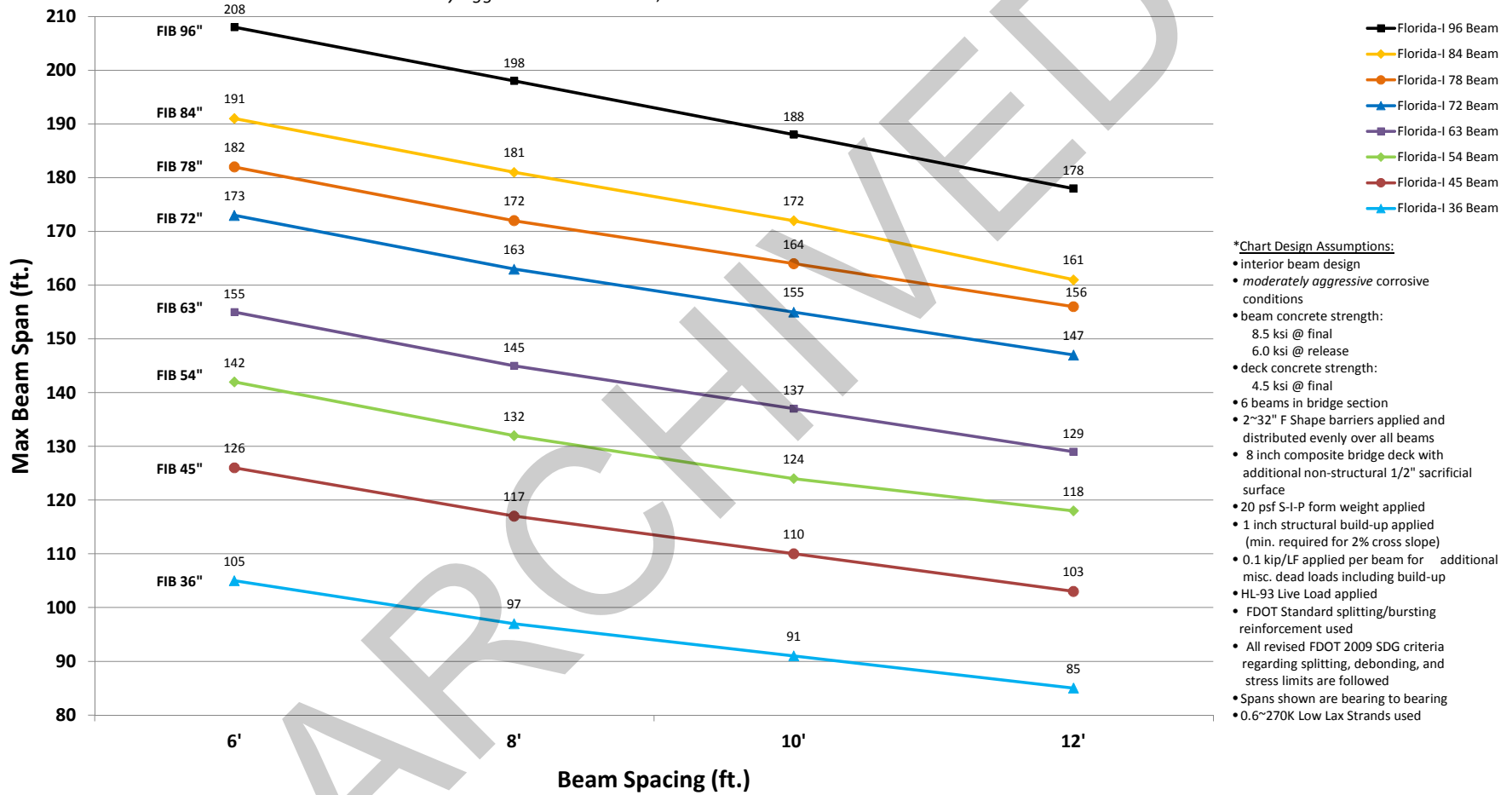

- \*Chart Design Assumptions:**
- interior beam design
  - moderately aggressive corrosive conditions
  - beam concrete strength:  
8.5 ksi @ final  
6.0 ksi @ release
  - deck concrete strength:  
4.5 ksi @ final
  - 6 beams in bridge section
  - 2~32" F Shape barriers applied and distributed evenly over all beams
  - 8 inch composite bridge deck with additional non-structural 1/2" sacrificial surface
  - 20 psf S-I-P form weight applied
  - 1 inch structural build-up applied (min. required for 2% cross slope)
  - 0.1 kip/LF applied per beam for additional misc. dead loads including build-up
  - HL-93 Live Load applied
  - FDOT Standard splitting/bursting reinforcement used
  - All revised FDOT 2009 SDG criteria regarding splitting, debonding, and stress limits are followed
  - Spans shown are bearing to bearing
  - 0.6~270K Low Lax Strands used

## Florida-I Beam Estimated Maximum Span Lengths

\*Extremely Aggressive Environment, FDOT Limits with 8.5 ksi Concrete

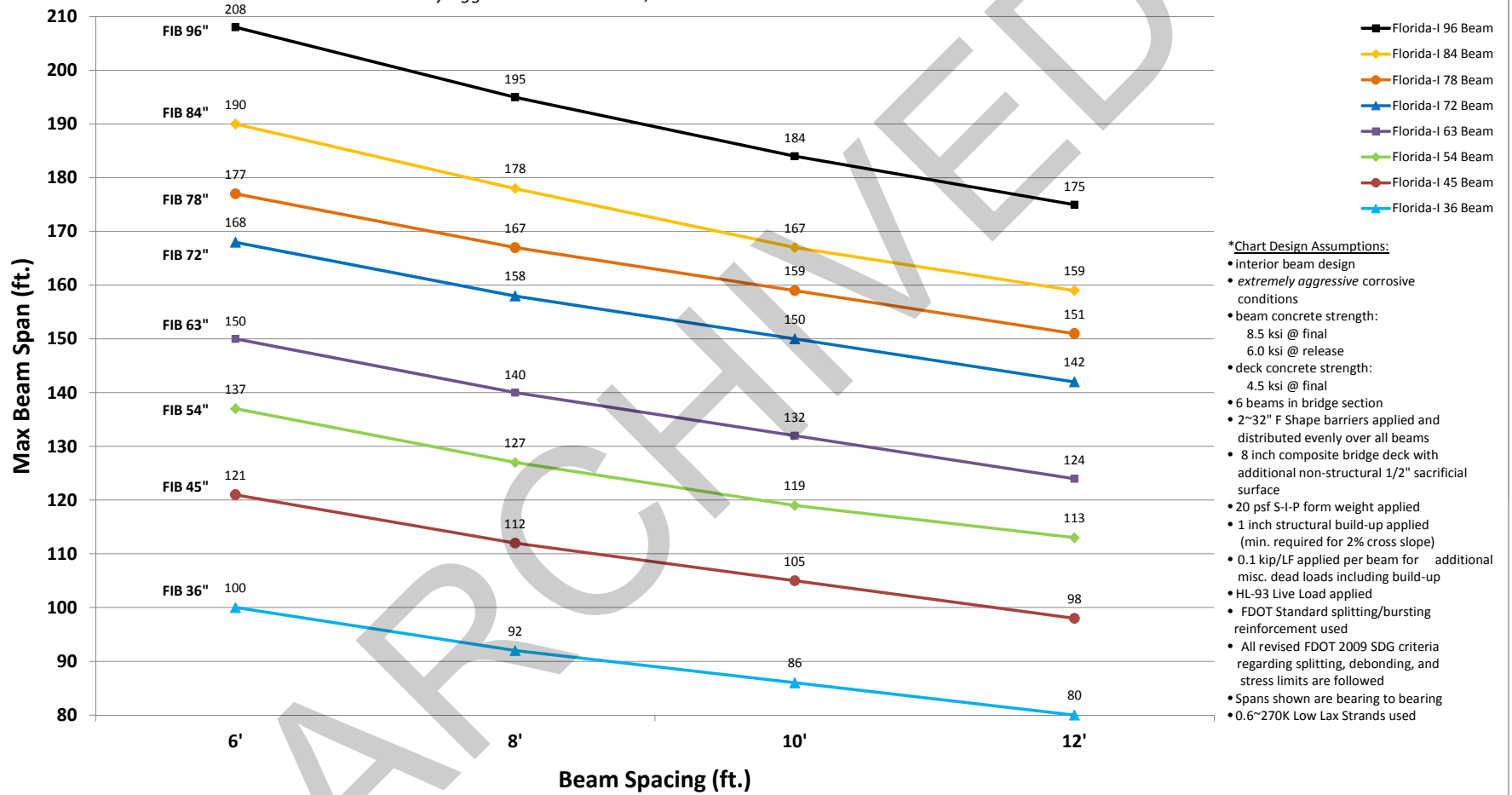

- \*Chart Design Assumptions:**
- interior beam design
  - extremely aggressive corrosive conditions
  - beam concrete strength:
    - 8.5 ksi @ final
    - 6.0 ksi @ release
  - deck concrete strength:
    - 4.5 ksi @ final
  - 6 beams in bridge section
  - 2~32" F Shape barriers applied and distributed evenly over all beams
  - 8 inch composite bridge deck with additional non-structural 1/2" sacrificial surface
  - 20 psf S-I-P form weight applied
  - 1 inch structural build-up applied (min. required for 2% cross slope)
  - 0.1 kip/LF applied per beam for additional misc. dead loads including build-up
  - HL-93 Live Load applied
  - FDOT Standard splitting/bursting reinforcement used
  - All revised FDOT 2009 SDG criteria regarding splitting, debonding, and stress limits are followed
  - Spans shown are bearing to bearing
  - 0.6~270K Low Lax Strands used

**ATTACHMENT C**

ARCHIVED

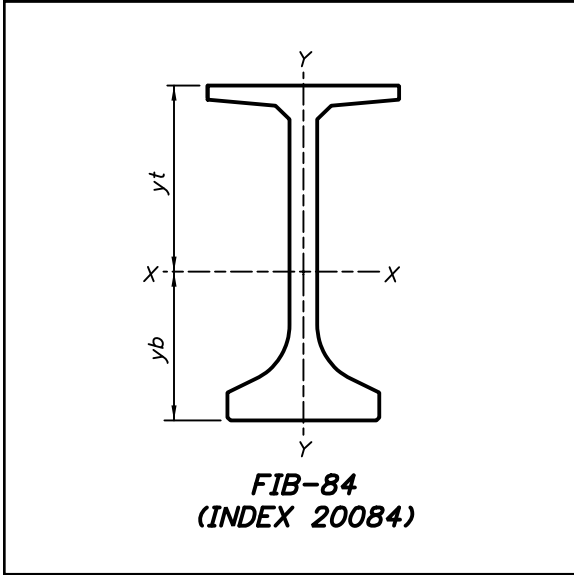

<b>FIB-84 SECTION PROPERTIES</b>	
Area (in. <sup>2</sup> )	1,142.58
Perimeter (in.)	302.57
I <sub>xx</sub> (in. <sup>4</sup> )	1.087 x 10 <sup>6</sup>
I <sub>yy</sub> (in. <sup>4</sup> )	82,442
y <sub>t</sub> (in.)	46.66
y <sub>b</sub> (in.)	37.34

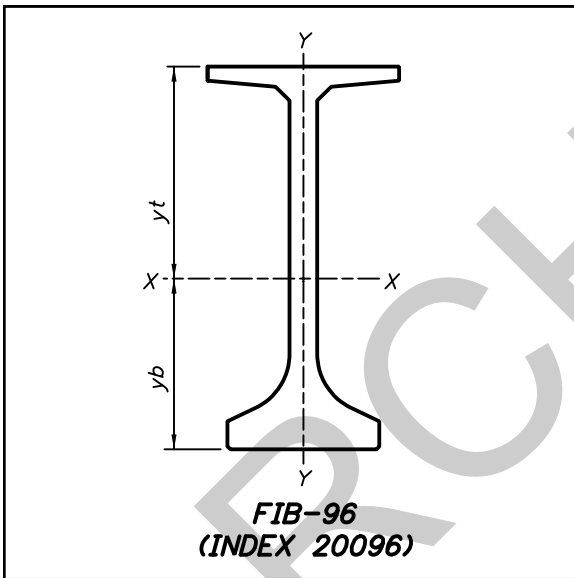

<b>FIB-96 SECTION PROPERTIES</b>	
Area (in. <sup>2</sup> )	1,226.58
Perimeter (in.)	326.57
I <sub>xx</sub> (in. <sup>4</sup> )	1.515 x 10 <sup>6</sup>
I <sub>yy</sub> (in. <sup>4</sup> )	82,785
y <sub>t</sub> (in.)	53.18
y <sub>b</sub> (in.)	42.82