



Florida Department of Transportation

CHARLIE CRIST
GOVERNOR

605 Suwannee Street
Tallahassee, FL 32399-0450

STEPHANIE C. KOPELOUSOS
SECRETARY

TEMPORARY DESIGN BULLETIN C09-01

DATE: January 21, 2009

TO: District Directors of Production, District Design Engineers, District Structures Design Engineers, District Construction Engineers, District Materials Engineers

FROM: Robert Robertson, P.E., State Structures Design Engineer

COPIES: Lora Hollingsworth, Brian Blanchard, Ghulam Mujtaba, Tom Malerk, Jeffrey Ger (FHWA)

SUBJECT: Implementation Plan for the Adoption of Florida I-Beams as New Standard Prestressed Concrete Beams

REQUIREMENTS

The new Florida I-Beams (FIB's) are standard prestressed concrete beams and will be used in all new bridge and bridge widening designs where applicable.

AASHTO and Florida Bulb-T Beams will not be used in new designs. This TDB does not affect Florida U and Florida Inverted-T Beams.

COMMENTARY

The following attachments may be used to assist in preliminary design and cost estimating:

- Attachment 'A' - FIB Section Dimensions
- Attachment 'B' - FIB Section Properties
- Attachment 'C' - FIB Estimated Maximum Span versus Spacing Charts.
- Attachment 'D' - Preliminary Bridge Cost Comparisons
- Attachment 'E' - FIB Table of Approximate Beam Cost per Linear Foot

BACKGROUND

The new Florida I-Beams have been developed in coordination with industry and with the help of Dr. Maher Tadros for the purpose of replacing currently used AASHTO Beams and Florida Bulb-T Beams. The FIB was developed to be more efficient to fabricate, safer to construct, and more cost effective when compared to currently used prestressed beams.

The FIB shape was designed to take advantage of today's higher concrete strengths, which typically ranges from 8 to 10 ksi. When compared to currently used AASHTO and Bulb-T Beams, the FIB shape employs a larger bottom flange to allow for more prestressing strands resulting in longer span capability and/or wider girder spacing. The improved effectiveness of the FIB should allow bridge designers to reduce the number of beams and lower bridge costs. Also, improved efficiency allows for shallower beams to be used where superstructure depth is a concern.

Compared to currently used beams of equivalent height, the FIB shape is more stable during fabrication, shipping, and construction due to its wider bottom flange and lower center of gravity.

The FIB heights were chosen to match standard beam heights to accommodate the widening of existing bridges. The intent of the beam heights chosen is to minimize the need for special designs.

IMPLEMENTATION

Florida I-Beams will be used on all Design-Bid-Build projects having both a design start date of February 1, 2009 or later and a letting date of July 1, 2010 or later. The FIB shall be used for preliminary design and estimates of projects with projected schedules falling on or after these dates.

AASHTO Beams and Florida Bulb-T Beams will no longer be used in Design-Bid-Build projects where the design start time is scheduled on or after February 1, 2009. Bridge Development Reports (BDR's) for these projects shall not include AASHTO Beams and Florida Bulb-T Beams in cost comparisons.

No currently designed projects will require a redesign as a result of this TDB, but Districts may elect to introduce FIB's into current designs at their discretion. For projects where the BDR already recommends an AASHTO or Florida Bulb-T beam design, the FIB may be substituted into the final design without issuing a BDR addendum.

Since implementation is dependent on the design start date, there will be a period of time where lettings have some projects with the new FIB's while others use the old AASHTO Beams and Florida Bulb-T Beams. For this transition period, the Design Standards will continue to include both the new FIB shapes and the old beam shapes.

The FIB's may be used on Design-Build projects at any time. Technical proposals utilizing FIB's will be accepted prior to the issuance of the FIB Design Standards. Any FIB's constructed prior to the issuance of the FIB Standards will require the Engineer of Record to complete the design. All current prestressed beam design criteria stated in the Structures Manual applies to FIB design.

Future changes to specifications and procedures are as follows:

1. Structures Manual

All references, updates, and instructions regarding the FIB will be issued with a TDB in May, 2009.

2. Design Standards

New 'Florida I-Beam', revised 'Elastomeric Bearing Pads', and revised 'Beveled Bearing Plate Detail' Standards Index Sheets will be released with the July 2009 Interims effective for lettings beginning January, 2010.

3. Standard Specifications

Section 450 – 'Precast Prestressed Concrete Construction': All references and updates regarding the FIB will be included in the FDOT January, 2010 Specifications Workbook.

4. Basis of Estimates

New Pay Items will be added to the FDOT Basis of Estimates Manual for lettings beginning January, 2010.

5. Plans Preparations Manual

No changes are anticipated at this time.

6. Misc. Design Tool Updates

- a. CADD: New FIB cells and tables in MicroStation & PDF format will be released with the July 2009 Interims and posted on the Structures Design website. These cells and tables will be included in the MicroStation Structures Menu with the Maintenance Release to follow.
- b. Design Software: The new FIB's will be included in the FDOT LRFD Prestressed Beam Program in May 2009. Proprietary software vendors will be contacted and given the new FIB section properties to be included for use in their design programs.

CONTACT

Sam Fallaha, P.E.
Assistant State Structures Design Engineer
Phone: (850)-414-4296, fax (850)-414-4955
e-mail: sam.fallaha@dot.state.fl.us

RVR/rms
Attachments

Attachment A

Florida I-Beam Section Dimensions

ARCHIVED

Attachment B

Florida I-Beam Section Properties

ARCHIVED

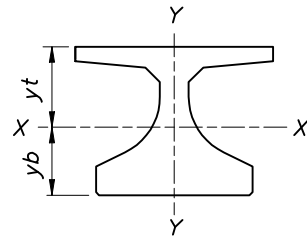

F.I.B.-36
(INDEX NO. 20036)

SECTION PROPERTIES 7" WEB	
Area (in ²)	806.58
Perimeter (in)	206.57
Ixx (in ⁴)	127,564
Iyy (in ⁴)	81,131
yt (in.)	19.51
yb (in.)	16.49

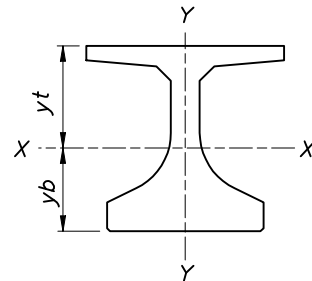

F.I.B.-45
(INDEX NO. 20045)

SECTION PROPERTIES 7" WEB	
Area (in ²)	869.58
Perimeter (in)	224.57
Ixx (in ⁴)	226,625
Iyy (in ⁴)	81,397
yt (in.)	24.79
yb (in.)	20.21

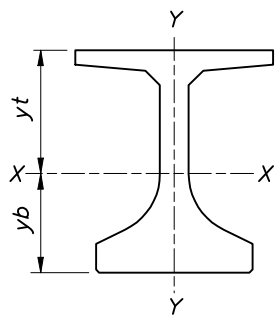

F.I.B.-54
(INDEX NO. 20054)

SECTION PROPERTIES 7" WEB	
Area (in ²)	932.58
Perimeter (in)	242.57
Ixx (in ⁴)	360,041
Iyy (in ⁴)	81,656
yt (in.)	29.97
yb (in.)	24.03

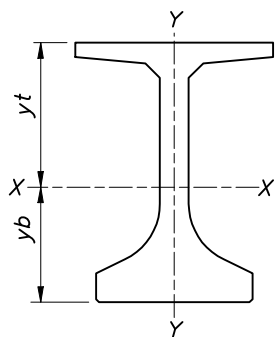

F.I.B.-63
(INDEX NO. 20063)

SECTION PROPERTIES 7" WEB	
Area (in ²)	995.58
Perimeter (in)	260.57
Ixx (in ⁴)	530,560
Iyy (in ⁴)	81,919
yt (in.)	35.06
yb (in.)	27.94

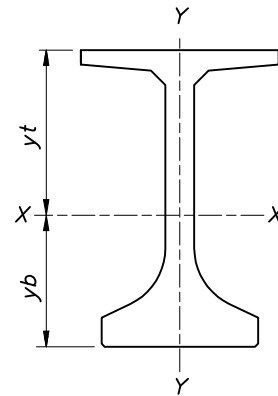

F.I.B.-72
(INDEX NO. 20072)

SECTION PROPERTIES 7" WEB	
Area (in ²)	1,058.58
Perimeter (in)	278.57
Ixx (in ⁴)	740,895
Iyy (in ⁴)	82,187
yt (in.)	40.09
yb (in.)	31.91

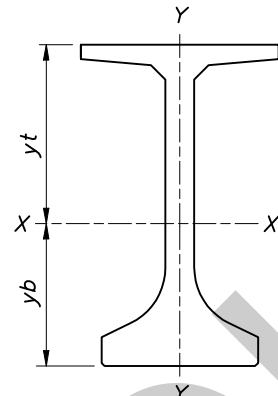

F.I.B.-78
(INDEX NO. 20078)

SECTION PROPERTIES 7" WEB	
Area (in ²)	1,100.58
Perimeter (in)	290.57
Ixx (in ⁴)	904,567
Iyy (in ⁴)	82,367
yt (in.)	43.40
yb (in.)	34.60

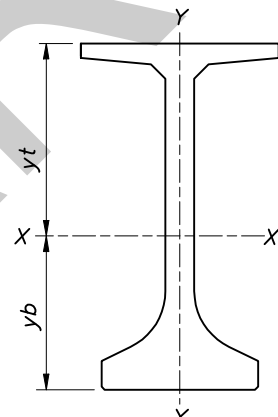

F.I.B.-84
(INDEX NO. 20078)

SECTION PROPERTIES 7" WEB	
Area (in ²)	1,142.58
Perimeter (in)	302.57
Ixx (in ⁴)	1,087,877
Iyy (in ⁴)	82,543
yt (in.)	46.70
yb (in.)	37.30

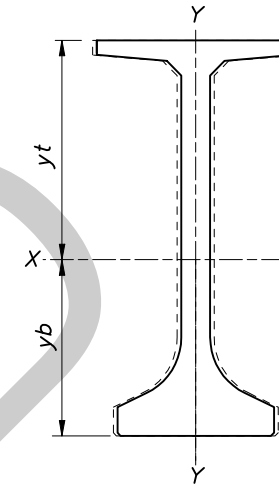

F.I.B.-96
(INDEX NO. 20054)

SECTION PROPERTIES 7" WEB	
Area (in ²)	1,226.58
Perimeter (in)	326.57
Ixx (in ⁴)	1,516,558
Iyy (in ⁴)	82,888
yt (in.)	53.22
yb (in.)	42.78

SECTION PROPERTIES 8" WEB	
Area (in ²)	1,322.58
Perimeter (in)	328.57
Ixx (in ⁴)	1,592,724
Iyy (in ⁴)	90,400
yt (in.)	52.85
yb (in.)	43.15

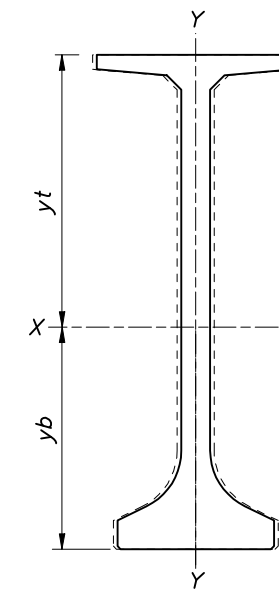

F.I.B.-120
(INDEX NO. 20012)

SECTION PROPERTIES 7" WEB	
Area (in ²)	1,394.58
Perimeter (in)	374.57
Ixx (in ⁴)	2,644,358
Iyy (in ⁴)	83,598
yt (in.)	66.10
yb (in.)	53.90

SECTION PROPERTIES 8" WEB	
Area (in ²)	1,514.58
Perimeter (in)	376.57
Ixx (in ⁴)	2,792,476
Iyy (in ⁴)	91,452
yt (in.)	65.62
yb (in.)	54.38

PRELIMINARY AND SUBJECT TO CHANGE

Attachment C

Florida I-Beam Estimated Maximum Span Versus Spacing Charts (Preliminary)

ARCHIVED

Florida I-Beam Estimated Maximum Span Lengths

FDOT Limits with 8.5 ksi Concrete

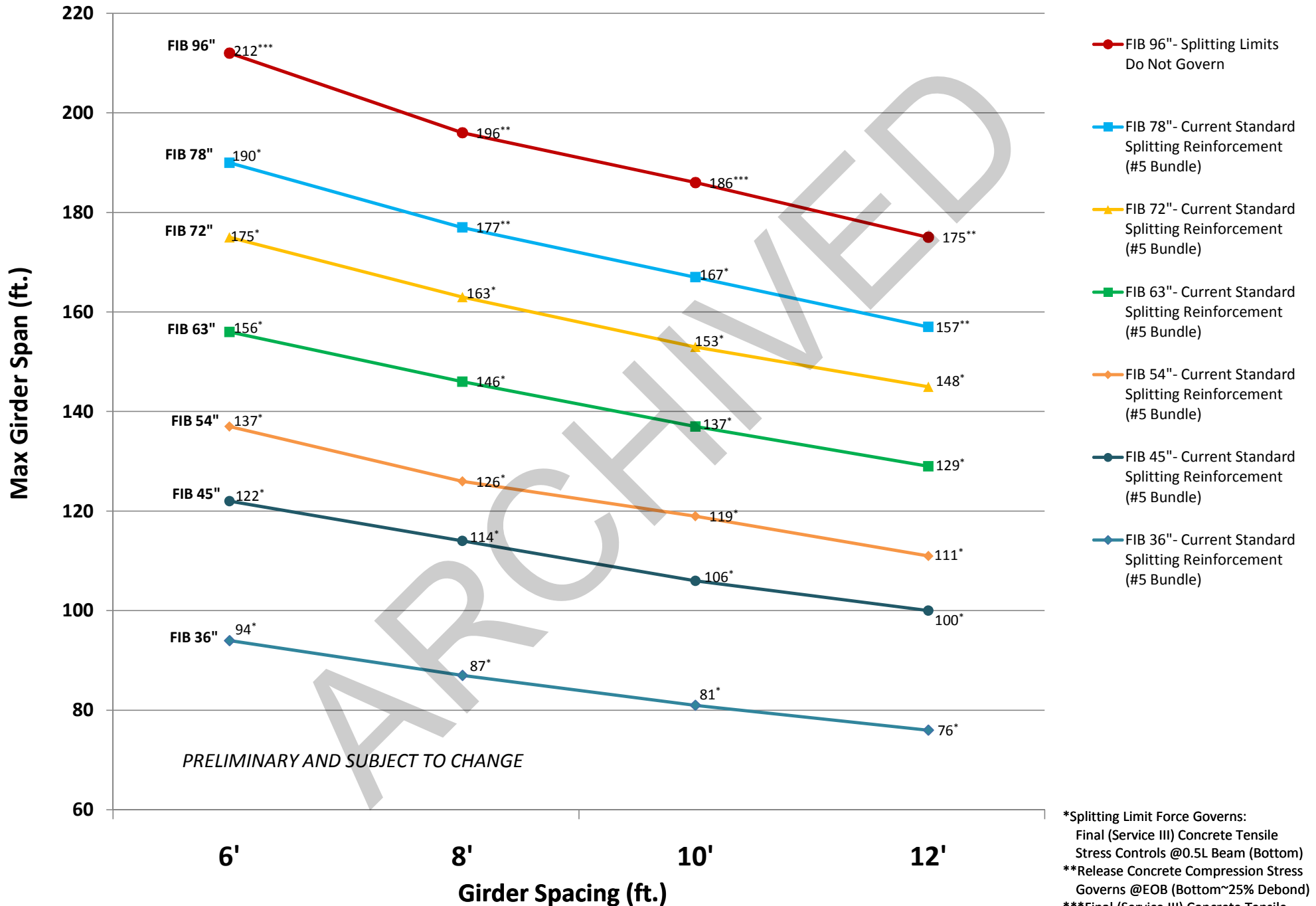

PRELIMINARY AND SUBJECT TO CHANGE

*Splitting Limit Force Governs:
 Final (Service III) Concrete Tensile Stress Controls @0.5L Beam (Bottom)
 **Release Concrete Compression Stress Governs @EOB (Bottom~25% Debond)
 ***Final (Service III) Concrete Tensile Stress Governs @EOB (Top)

Florida I-Beam Estimated Maximum Span Lengths

FDOT Limits with 10 ksi Concrete

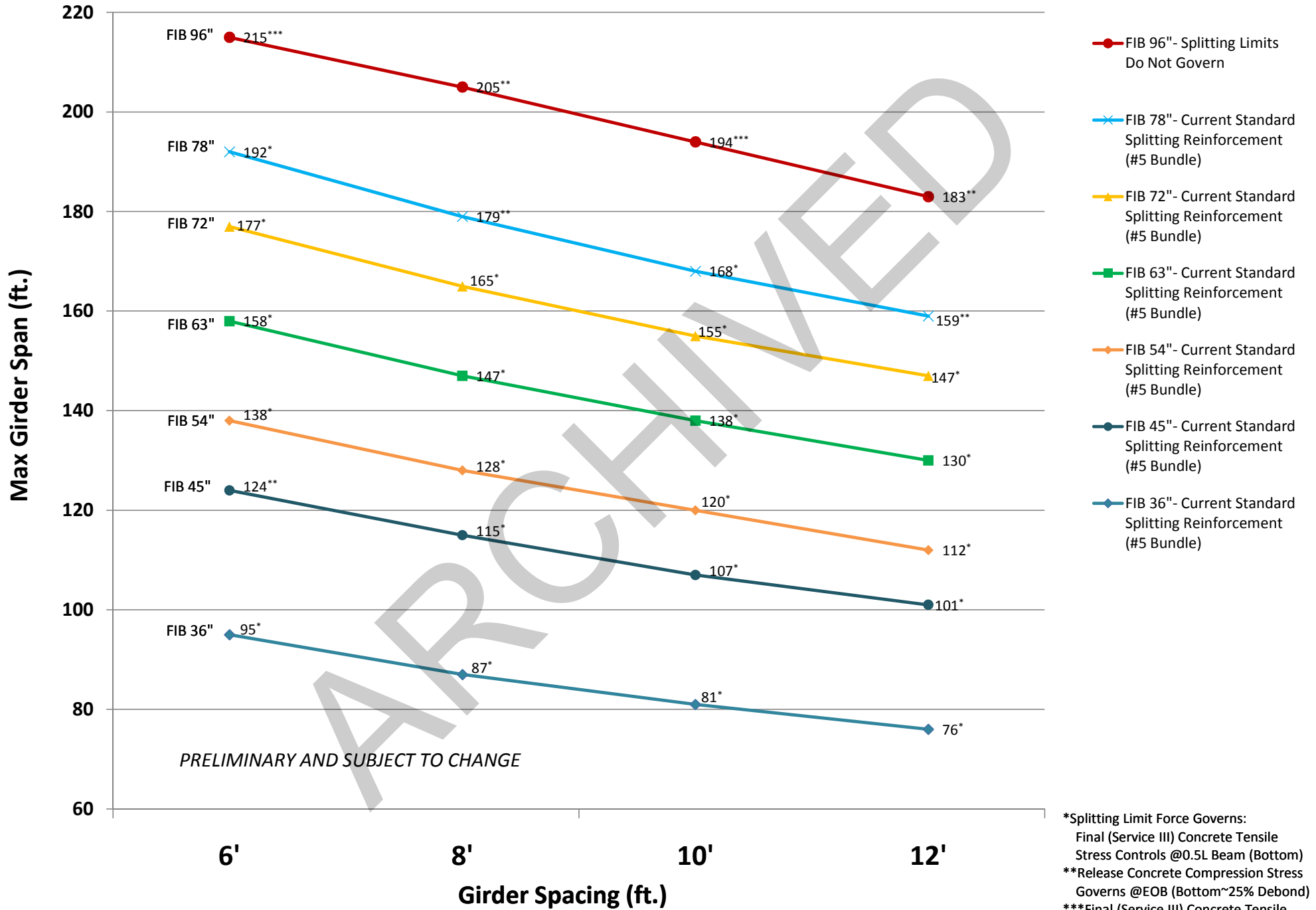

PRELIMINARY AND SUBJECT TO CHANGE

*Splitting Limit Force Governs:
 Final (Service III) Concrete Tensile Stress Controls @0.5L Beam (Bottom)
 **Release Concrete Compression Stress Governs @EOB (Bottom~25% Debond)
 ***Final (Service III) Concrete Tensile Stress Governs @EOB (Top)

Girder Maximum Span Length Comparisons

FDOT Limits with 8.5 ksi Concrete

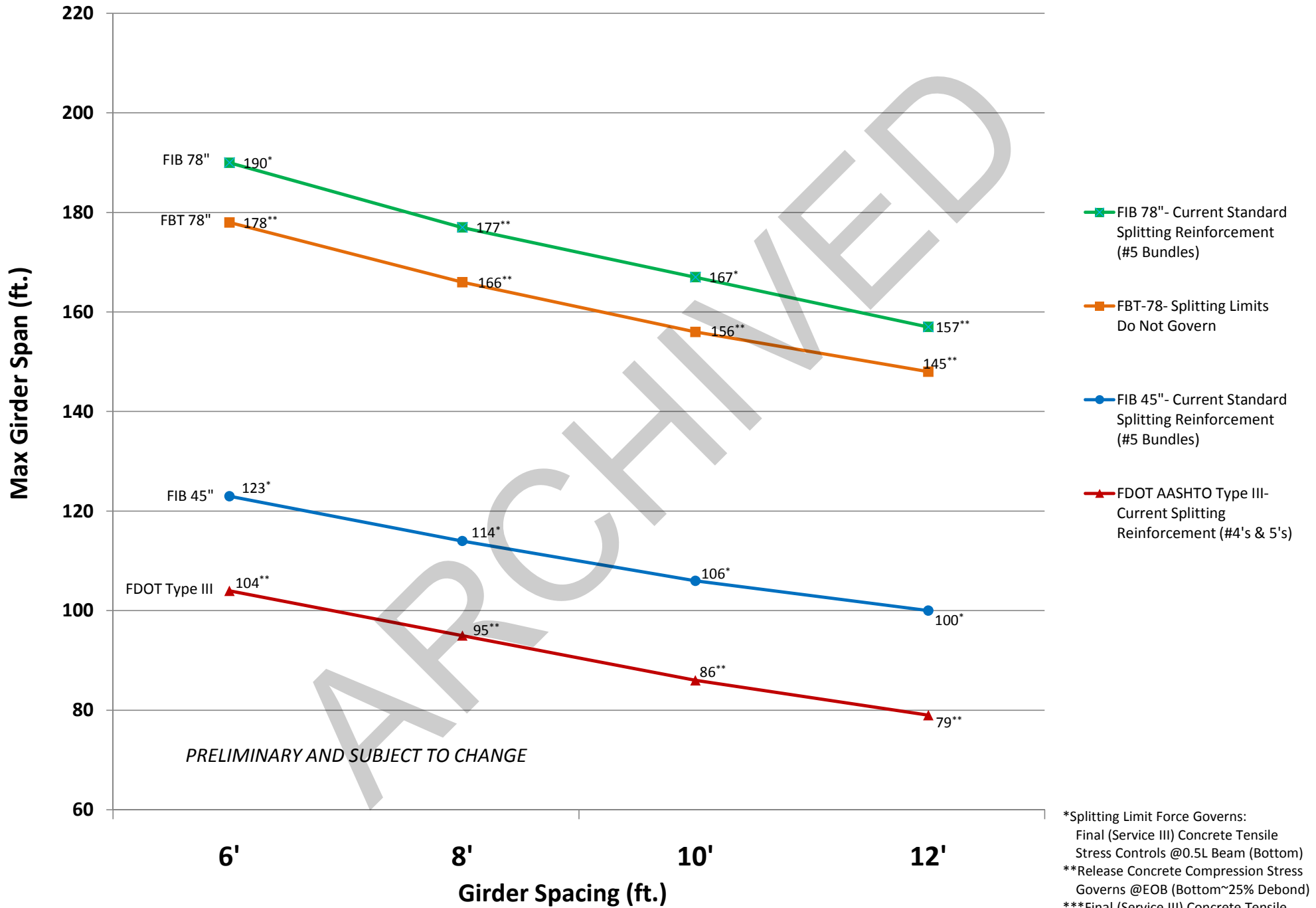

PRELIMINARY AND SUBJECT TO CHANGE

*Splitting Limit Force Governs:
 Final (Service III) Concrete Tensile Stress Controls @0.5L Beam (Bottom)
 **Release Concrete Compression Stress Governs @EOB (Bottom~25% Debond)
 ***Final (Service III) Concrete Tensile Stress Governs @EOB (Top)

Attachment D

Preliminary Bridge Cost Comparisons

ARCHIVED

COST COMPARISON A; 3 ~ 90 FT. SPANS BRIDGE

OPTION A-1, CURRENT FDOT STANDARD BEAMS

AASHTO TYPE III:

(90 ft.) x (3 spans) x (6 beams) = 1620 LF
 1620 LF @ \$185/LF = \$299,700

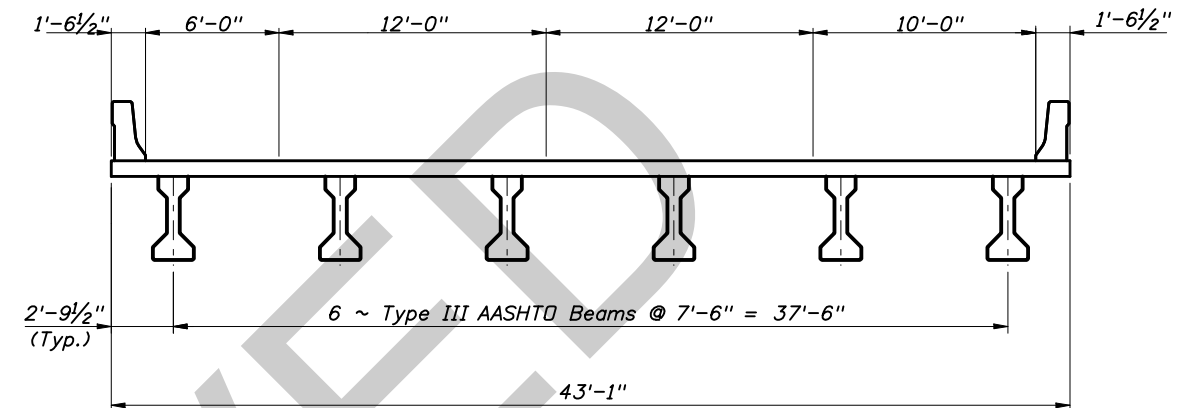

"AASHTO Type III" w/26 ~ 0.6 Low Lax Strands,
 2008 FDOT Standards Index No. 20130 Reinforcing Steel
 8.5 ksi Concrete; 6 ksi @ Release

OPTION A-2, FLORIDA I-BEAMS

FIB-45:

(90 ft.) x (3 spans) x (4 beams) = 1080 LF
 1080 LF @ \$210/LF = \$226,800

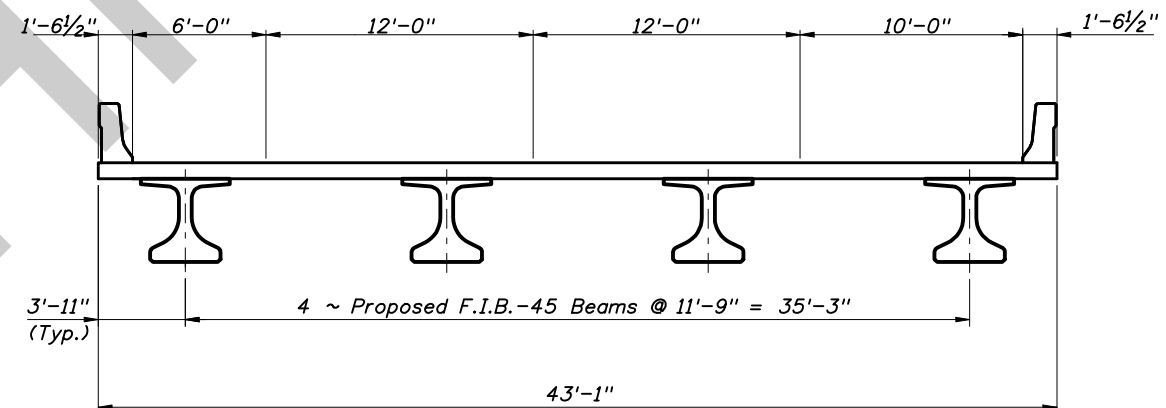

"Florida I-Beam 45" w/42 ~ 0.6 Low Lax Strands
 2008 FDOT Standards Index No. 20130 Reinforcing Steel
 [Substitute 5K (No. 5 bars) for 4K]
 8.5 ksi Concrete; 6 ksi @ Release

ESTIMATED SAVINGS:

$\$299,700 - \$226,800 = \$72,900$
 $\$72,900 / \$299,700 = 24\%$

Note:

Costs per linear foot were determined using price estimates from manufactures and contractors. The values above include only bridge items affected by differing beam types. These items include beam fabrication, beam placement, placed bearing pads, placed diaphragms, placed stay-in-place forms, and placed deck rebar seats.

REVISIONS						STRUCTURES DESIGN OFFICE CENTRAL OFFICE 605 Suwannee Street, MS 33 Tallahassee, Florida 32399-0450	STATE OF FLORIDA DEPARTMENT OF TRANSPORTATION			SHEET TITLE: COST COMPARISON SPANS OLD STANDARD VS. FLORIDA I-BEAMS		REF. DWG. NO.
DATE	BY	DESCRIPTION	DATE	BY	DESCRIPTION		ROAD NO.	COUNTY	FINANCIAL PROJECT ID	PROJECT NAME	SHEET NO.	
						N/A		N/A		N/A	1 OF 2	

Attachment E

Florida I-Beam Table of Approximate Beam Cost Per Linear Foot

Beam Type	Area (in ²)	Unit Weight (kip/ft)	*Estimated Beam Cost (\$/ft)
FIB 36	806.6	840	190
FIB 45	869.6	906	205
FIB 54	932.6	971	220
FIB 63	995.6	1037	235
FIB 72	1058.6	1103	250
FIB 78	1100.6	1146	260
FIB 84	1142.6	1190	270
FIB 96	1226.6	1278	290

*Price based on precast fabricators' survey estimate of 15% greater cost per unit length as compared to past standard AASHTO & Florida Bulb-T Beams of equivalent height.