



Florida Department of Transportation

JEB BUSH
GOVERNOR

605 Suwannee Street
Tallahassee, FL 32399-0450

DENVER J. STUTLER, JR.
SECRETARY

July 15, 2005

MEMORANDUM

TO: District Directors of Operations
(Debbie Hunt, Nick Tsengas, Jimmy Rodgers, James Wolfe, Gus Pego, Jim Moulton, Jr., Bruce Seiler)
District Directors of Production
(Chris Smith, Larry Parks, Tommy Barfield, Gerry O'Reilly, Noranne Downs, Javier Rodriguez, Donald Skelton, Nancy Clements)
District Structures Design Engineers
(Gerard Moliere, Rod Nelson, Keith Shores, John Danielsen, Neil Kenis, Kim Saing, Jose Rodriguez, and Agnes Spielmann)
District Structures and Facilities Engineers
(Pepe Garcia, Keith Campbell, John Locke, Jose Quintana, Ron Meade, Frank Guyamier, Chris Toenjes)
District Drainage Engineers
(John Previte, Ron Cox, Jim Kampinos, Francis Lewis, Patrick Muench, Ricardo Salazar, Megan Arasteh, Kevin Stewart)

FROM: William Nickas, P.E., State Structures Design Engineer
Brian Blanchard, P.E. State Roadway Design Engineer

COPIES: Bob Greer, Jeffrey Ger (FHWA), Brian Blanchard, Ananth Prasad, Duane Brautigam, Sharon Holmes, John Harris, Robert Robertson, Marcus Ansley, Larry Jones, David O'Hagan, Steve Plotkin, Rick Renna.

SUBJECT: Temporary Design Bulletin CO5-08
Slope Protection Details

REQUIREMENTS

Replace Structures Detailing Manual Sheet No. EX-4 with the attached Sheets Nos. EX-4a & EX-4b.

COMMENTARY

The general details shown for Rubble Riprap Protection Adjacent to Streams on Sheet No. EX-4 have not proven to be durable. During design storm events, the filter fabric underlying the slope protection rock pulls away from the abutment, wing wall and/or approach slab. To better anchor the filter fabric, sand-cement riprap shall now be stacked around these bridge elements as shown on the new example sheets (EX.-4a & 4b). These details may only be superseded by a design from a registered hydraulics engineer.

The details shown on EX-4a & EX-4b shall also be used for emergency repairs of slopes eroded around coastal bridges, or any bridge whose embankment approaches and/or abutments are subject to waves more than 3' in height, if all of the following are applicable:

- a. The previous design was not engineered by a registered coastal engineer but simply based on the details shown on Sheet EX-4. The sand-cement riprap shall anchor the filter fabric underneath the slope protection rock, as shown in Section B-B on EX-4b, for the full longitudinal extent of the riprap or 15' from the front face of the abutment backwall, whichever is greater.
- b. A project-specific design by a registered coastal engineer is not available for immediate construction.

By replacing Sheet No. EX-4 with EX-4a & EX-4b, the "Sand-Cement Riprap Protection Adjacent to Railroad Track" details are being temporarily deleted. The State Structures Design Office will be in contact with the Railroads to determine if these details are still desirable.

BACKGROUND

None.

IMPLEMENTATION

Incorporate immediately on all emergency riprap repair projects.

Incorporate immediately into all Design/Bid/Build projects where bridge designs are at or less than 60% complete.

Incorporate immediately into all Design/Build projects where proposals have not been received as of the date of this Bulletin.

CONTACT

David C. O'Hagan, PE
Assistant State Structures Design Engineer
(850) 414-4283
david.ohagan@dot.state.fl.us

WNN/DOH

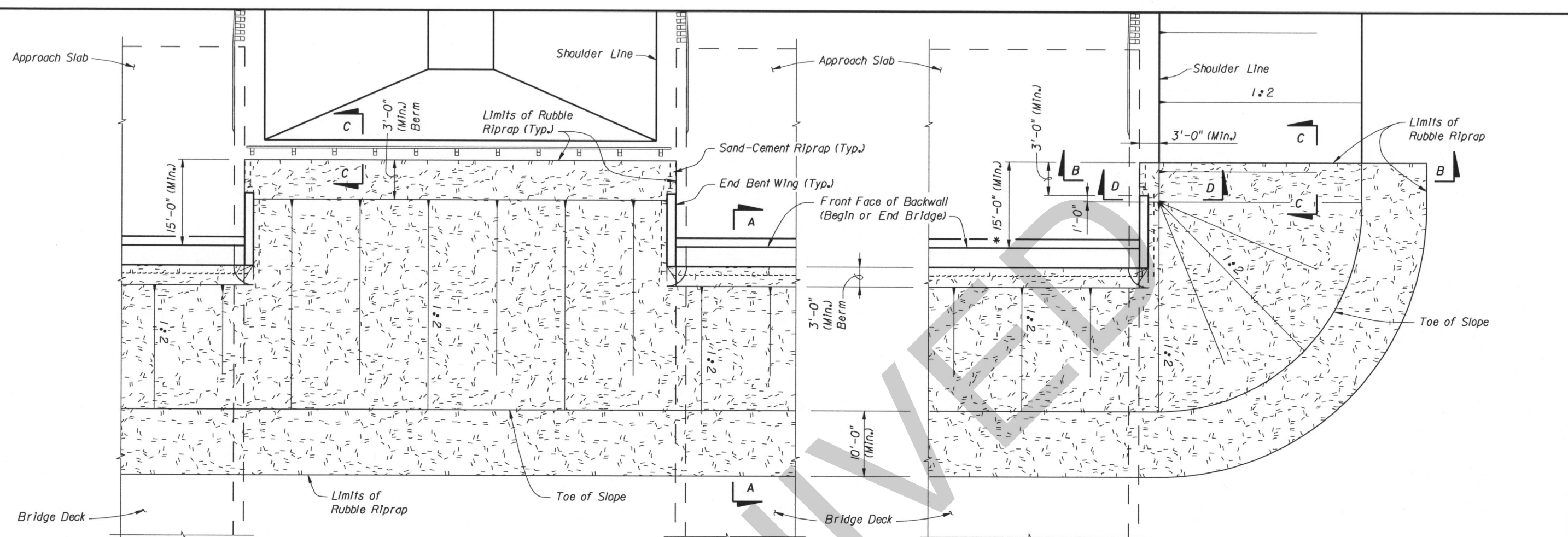

PARTIAL PLAN VIEW INSIDE AREA (MEDIAN) DUAL BRIDGES
(Bridge Deck and Approach Slab shown Dashed)

PARTIAL PLAN VIEW OUTSIDE AREA SINGLE OR DUAL BRIDGES
(Bridge Deck and Approach Slab shown Dashed)

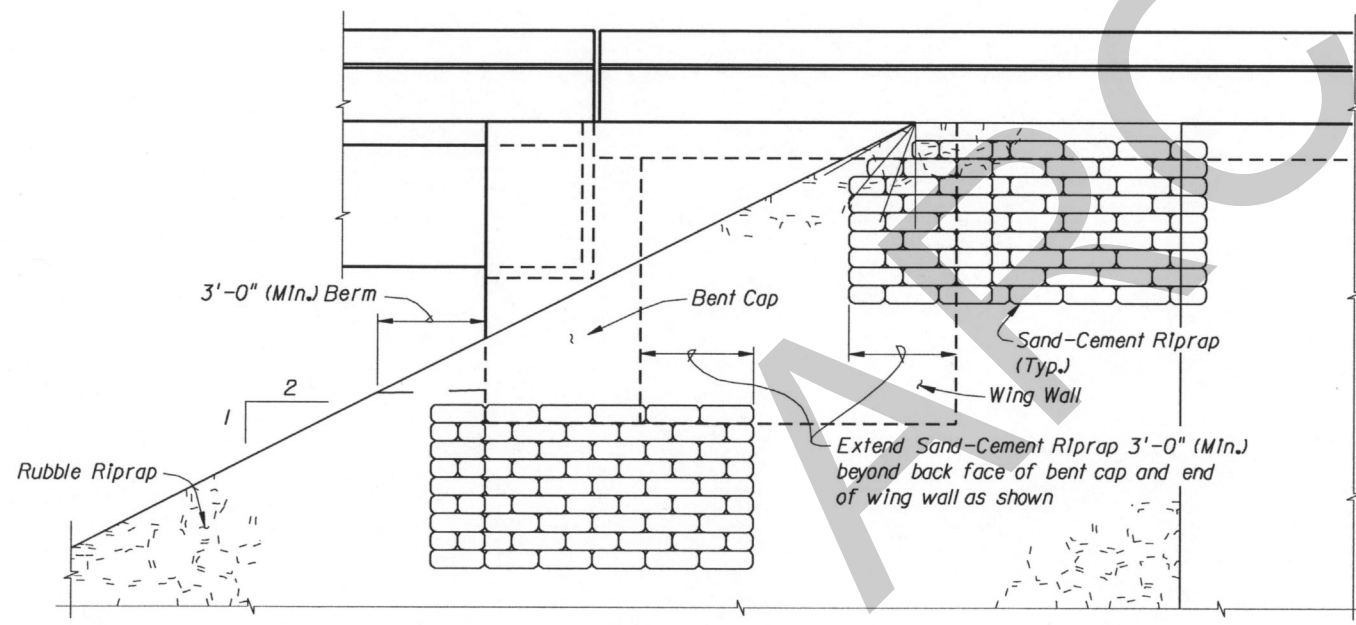

PARTIAL SIDE ELEVATION

NOTE:
For Section A-A, B-B, C-C & D-D see Sheet EX-4b.

NOTES TO DESIGNER:
* Longitudinal extent of riprap shall be extended beyond 15' from front face of Backwall if required by the Engineer.
For regions subject to waves over 3', a Coastal Engineer shall design the Slope Protection System.

BRIDGE NO. XXXXXX

| REVISIONS | | | | | | DRAWN BY | | ENGINEER OF RECORD, EOR Name, P.E. Registration/P.E. No. 000000 Engineering Co. Name/Logo Address Certificate of Authorization No. | FLORIDA DEPARTMENT OF TRANSPORTATION | | | SHEET TITLE | |
|-----------|----|-------------|------|----|-------------|----------|-------|---|--------------------------------------|--------|----------------------|--------------------------------------|--|
| DATE | BY | DESCRIPTION | DATE | BY | DESCRIPTION | ABC | MO-YR | | ROAD NO. | COUNTY | FINANCIAL PROJECT ID | SLOPE PROTECTION ADJACENT TO STREAMS | |
| | | | | | | DEF | MO-YR | | | | | PROJECT NAME | |
| | | | | | | GHI | MO-YR | | | XXXX | 123456-1-12-12 | DETAILING MANUAL EXAMPLES | |
| | | | | | | JKL | MO-YR | | | | SHEET NO. | | |
| | | | | | | MNO | | | | | EX-4a | | |

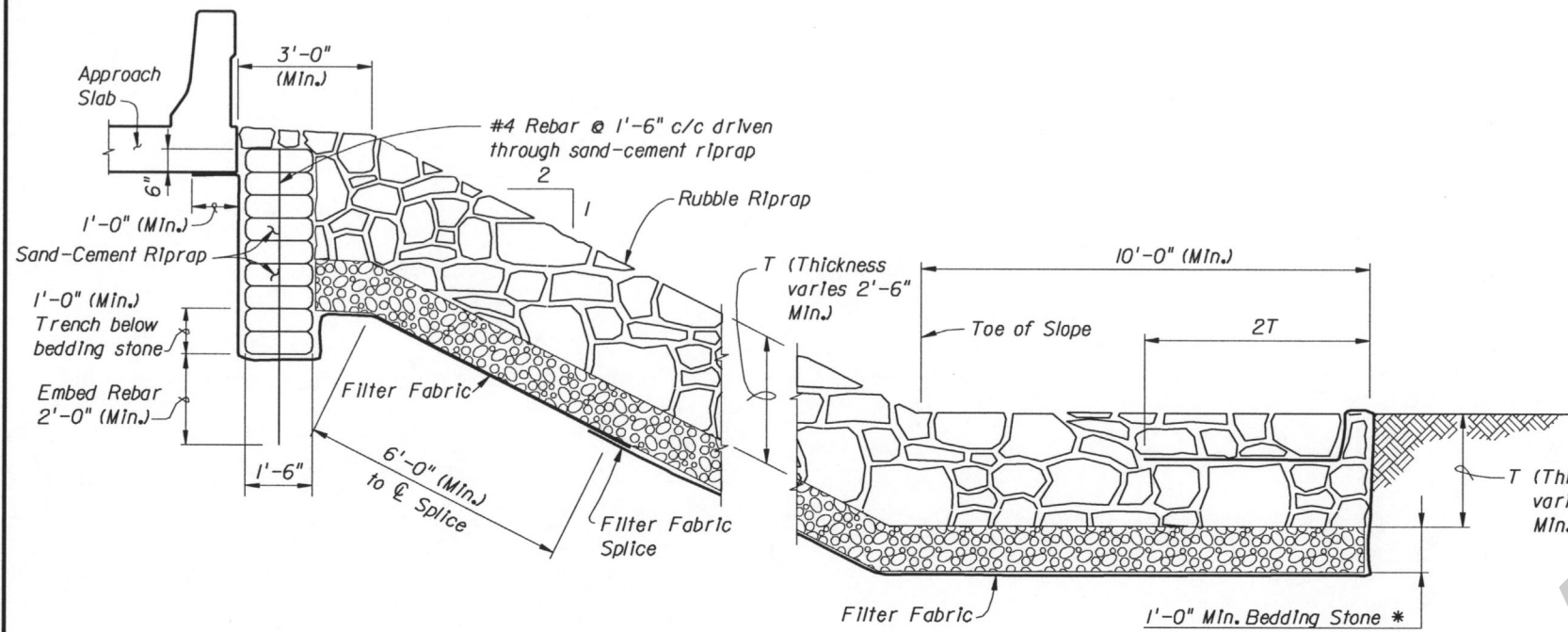

SECTION B-B

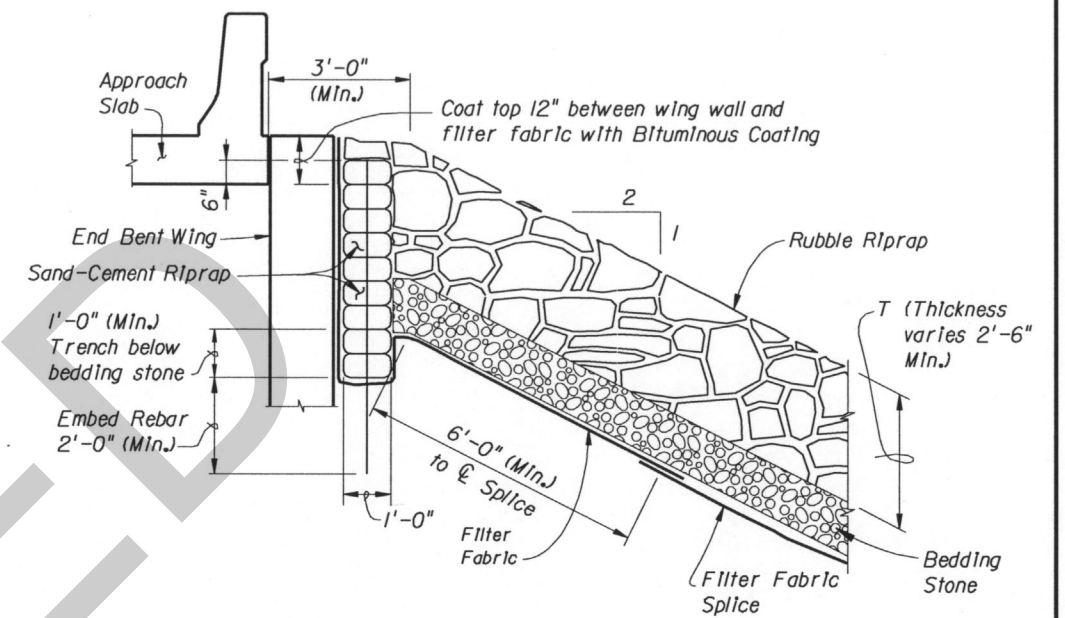

SECTION D-D

NOTE:
Filter Fabric shall be Type D-2,
see Design Standard Index 199.
Splice length shall be 6" if bedding
stone specified or 2'-0" if no
bedding stone specified.

For location of Section A-A, B-B,
C-C & D-D see Sheet EX-4a.

* Provide Bedding Stone unless
otherwise shown on the Bridge
Hydraulic Recommendations sheet.

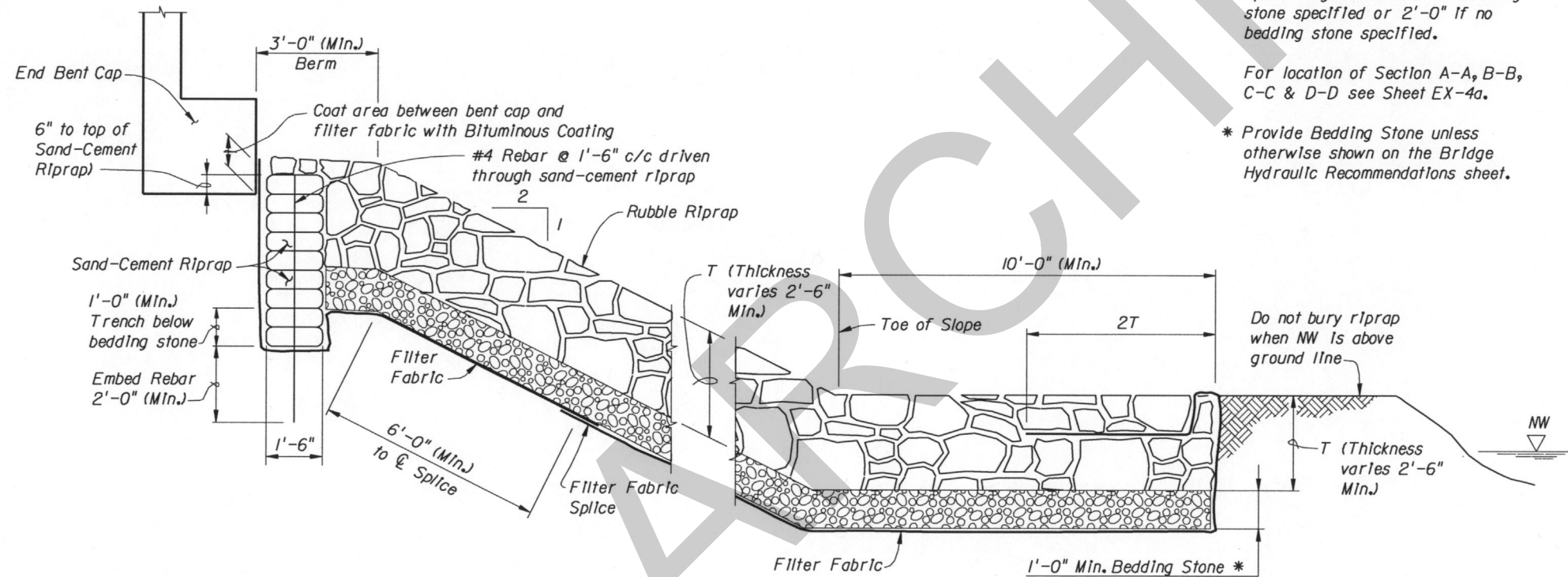

SECTION A-A

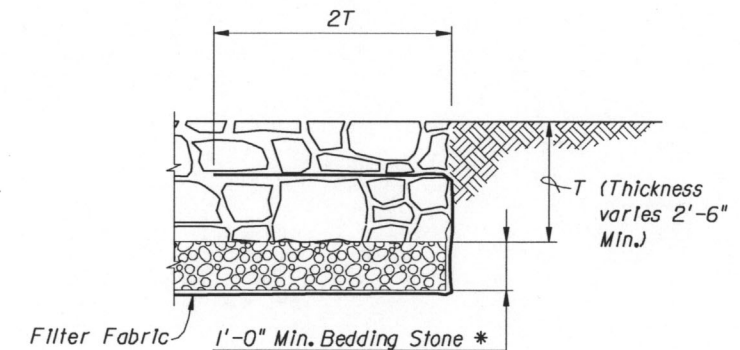

SECTION C-C

BRIDGE NO. XXXXXX

| REVISIONS | | | | | | NAMES | | DATES | | ENGINEER OF RECORD | | | FLORIDA DEPARTMENT OF TRANSPORTATION | | | SHEET TITLE | |
|-----------|----|-------------|------|----|-------------|-------------|-----|-------|----------------------------------|--------------------|--------|----------------------|--------------------------------------|--|--------------|-------------|--|
| DATE | BY | DESCRIPTION | DATE | BY | DESCRIPTION | DRAWN BY | ABC | MO-YR | ENGINEER OF RECORD | ROAD NO. | COUNTY | FINANCIAL PROJECT ID | SLOPE PROTECTION ADJACENT TO STREAMS | | PROJECT NAME | SHEET NO. | |
| | | | | | | CHECKED BY | DEF | MO-YR | EOR Name, P.E. | | | | DETAILING MANUAL EXAMPLES | | | EX-4b | |
| | | | | | | DESIGNED BY | GHI | MO-YR | Registration/P.E. No. 000000 | | | | | | | | |
| | | | | | | CHECKED BY | JKL | MO-YR | Engineering Co. Name/Logo | | | | | | | | |
| | | | | | | APPROVED BY | MNO | | Address | | XXXX | 123456-1-12-12 | | | | | |
| | | | | | | | | | Certificate of Authorization No. | | | | | | | | |