

920 Soil Survey Sheet and Boring Coring Data

920.1 General

This chapter provides the requirements for the development of Soil Survey sheets and Boring Cross Sections sheets.

Place a core bore symbol on the Roadway Plan-Profile sheet at the location (station/offset) that the bore was taken. Label the symbol with the assigned bore number.

Refer to the [FDOT Soils and Foundation Handbook](#) for additional information.

920.2 Soil Survey Sheet

The Soil Survey sheet describes the various types of soils encountered within the limits of the project, including the environmental classification, mechanical properties, and recommended usage of those soils. A preformatted CADD sheet can be found in the FDOT CADD Software. This sheet is typically prepared using a standard-format sheet (11"x17").

Assign a stratum number and provide a description of the material encountered. Include the results for the following tests (as applicable):

- Organic Content
- Moisture Content
- Sieve Analysis
- Atterberg Limits
- Corrosion Test

Assign (group) soils having the same characteristics. Include applicable notes regarding each stratum group on this sheet. Provide the date and weather conditions at the time of sampling.

Include a legend for any symbology used in the Boring Cross Section sheets.

Refer to **Exhibit 920-1** for an example of Soil Survey sheet and **Exhibit 920-2** for the Report of Core Borings.

920.3 Boring Cross Sections Sheets

Boring Cross Section sheets display the results of each core boring on a cross section at the station and offset at which the boring was taken. To create these sheets, Final Geotechnical Data must be deliverable in a xml file (3D model) generated from the FDOT

Geotechnical Data Manager (GDM) application. Cross sections are generated, inclusive of all core boring locations, in conformance with the requirements contained in **FDM 905**. Show the core bores on the corresponding cross section as a ¼-inch wide column below the ground line. Show stratum limits at appropriate depth and assigned stratum numbers inside the column.

920.3.1 Report of Core Borings Sheets

When the Geotechnical Data is not available in a xml file (3D model), or there are only a few core borings, core boring illustrations can be shown on Report of Core Borings sheets instead of Boring Cross Section sheets.

Show the core bores as a ¼-inch wide column below the ground line with a vertical scale adjacent to the core to indicate depth. Show stratum limits at appropriate depth and assigned stratum numbers inside the column.

When there are only a few isolated cores, the soil survey data is often included on the Report of Core Borings sheet.

STATE OF FLORIDA
DEPARTMENT OF TRANSPORTATION
MATERIALS AND RESEARCH

DATE OF SURVEY: 2/15/2018-5/1/2018
SURVEY MADE BY: SOIL SURVEY, INC.
SUBMITTED BY: LEIA I. CROSSWELL, P.E.
DISTRICT: THREE

FINANCIAL PROJECT ID : 123456-1-52-01
PROJECT NAME: SR 22 (WEWA HWY)

CROSS SECTION SOIL SURVEY FOR THE DESIGN OF ROADS

SURVEY BEGINS STA. : 125+87 SURVEY ENDS STA. : 442+67 REFERENCE: BASELINE SURVEY

STRATUM NO.	ORGANIC CONTENT		MOISTURE CONTENT		SIEVE ANALYSIS RESULTS PERCENT PASS (%)					ATTERBERG LIMITS (%)			DESCRIPTION	CORROSION TEST RESULTS						
	NO. OF TESTS	% ORGANIC	NO. OF TESTS	MOISTURE CONTENT	NO. OF TESTS	10 MESH	40 MESH	60 MESH	100 MESH	200 MESH	NO. OF TESTS	LIQUID LIMIT		PLASTIC INDEX	AASHTO GROUP	NO. OF TESTS	RESISTIVITY ohm-cm	CHLORIDE ppm	SULFATES ppm	pH
1	1	1	1	6	14	100	82-88	39-41	12-16	5-10	--	--	--	A-3	GRAY TO BROWN SAND TO SAND WITH SILT	3	14,000-17,000	15	<4.8	7.1-7.9
2	--	--	--	--	9	100	68-78	36-37	15-21	11-34	--	--	--	A-2-4	LIGHT BROWN TO BROWN SILTY SAND	1	22,000	15	<4.8	--
3	--	--	11	7-18	11	100	77-80	41-46	27-30	20-34	11	25-34	11-18	A-2-4/A-2-6	LIGHT GRAY TO BROWN SILTY SAND TO CLAYEY SAND	--	--	--	--	--
4	54	5-56	54	17-575	54	--	--	--	--	4-64	--	--	--	A-8	DARK BROWN TO BLACK SAND TO SILTY SAND WITH ORGANIC MATERIAL	--	--	--	--	--
5	13	1-4	13	9-38	13	--	--	--	--	5-10	--	--	--	A-3/A-2-4	DARK BROWN SAND TO SAND WITH SILT WITH TRACE ORGANICS	--	--	--	--	--
6	--	--	18	11-35	18	--	--	--	--	36-76	18	22-49	10-26	A-6/A-7-6	GRAY CLAYEY SAND TO SANDY CLAY TO CLAY	--	--	--	--	--
7	--	--	7	19-31	8	100	86-89	58-73	47-68	45-66	7	51-66	32-42	A-7-5/A-7-6	GREEN TO BROWN CLAYEY SAND TO CLAY	--	--	--	--	--

NOTES:

- THE MATERIAL FROM STRATUM 1 (A-3) APPEARS SATISFACTORY FOR USE IN THE EMBANKMENT WHEN UTILIZED IN ACCORDANCE WITH STANDARD PLANS, INDEX 120-001.
- THE MATERIAL FROM STRATUM 2 (A-2-4) APPEARS SATISFACTORY FOR USE IN THE EMBANKMENT WHEN UTILIZED IN ACCORDANCE WITH STANDARD PLANS, INDEX 120-001. HOWEVER, THIS MATERIAL IS LIKELY TO RETAIN EXCESS MOISTURE AND MAY BE DIFFICULT TO DRY AND COMPACT. IT SHOULD BE USED IN THE EMBANKMENT ABOVE THE WATER LEVEL EXISTING AT THE TIME OF CONSTRUCTION.
- THE MATERIAL FROM STRATA 3 AND 6 IS PLASTIC (A-2-4/A-2-6/A-6/A-7-6) MATERIAL AND SHALL BE REMOVED IN ACCORDANCE WITH STANDARD PLANS, INDEX 120-002 AND UTILIZED IN ACCORDANCE WITH STANDARD PLANS, INDEX 120-001.
- THE MATERIAL FROM STRATUM 7 IS HIGH PLASTIC (A-7-5/A-7-6) MATERIAL AND SHALL BE REMOVED IN ACCORDANCE WITH STANDARD PLANS, INDEX 120-002 AND UTILIZED IN ACCORDANCE WITH STANDARD PLANS, INDEX 120-001.
- THE MATERIAL FROM STRATUM 5 (A-2-4) APPEARS SATISFACTORY FOR USE IN THE EMBANKMENT WHEN UTILIZED IN ACCORDANCE WITH STANDARD PLANS, INDEX 120-001. HOWEVER, THIS MATERIAL MAY NOT BE USED IN THE SUBGRADE PORTION OF THE ROADBED DUE TO ITS ORGANIC CONTENT. THIS MATERIAL IS LIKELY TO RETAIN EXCESS MOISTURE AND MAY BE DIFFICULT TO DRY AND COMPACT. IT SHOULD BE USED IN THE EMBANKMENT ABOVE THE WATER LEVEL EXISTING AT THE TIME OF CONSTRUCTION.
- THE MATERIAL FROM STRATUM NUMBER 4 IS MUCK (A-8) MATERIAL AND SHALL BE REMOVED IN ACCORDANCE WITH STANDARD PLANS, INDEX 120-002. THE REMOVAL LIMITS ARE PRESENTED ON THE MUCK DELINEATION PLAN SHEETS AND THE ROADWAY CROSS-SECTIONS.

EMBANKMENT AND SUBGRADE MATERIAL

STRATA BOUNDARIES ARE APPROXIMATE. MAKE FINAL CHECK AFTER GRADING.

- ∇ - SEASONAL HIGH WATER TABLE
- ▼ - WATER TABLE ENCOUNTERED
- GNE - GROUNDWATER NOT ENCOUNTERED
- GNA - GROUNDWATER NOT APPARENT DUE TO THE INTRODUCTION OF DRILLING FLUID

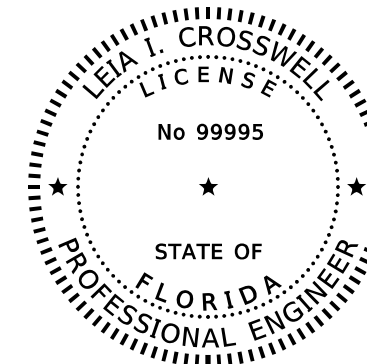

THIS ITEM HAS BEEN DIGITALLY SIGNED AND SEALED BY:

Leia I. Crosswell
2018.10.11 8:31:01 - 4'00'

ON THE DATE ADJACENT TO THE SEAL

PRINTED COPIES OF THIS DOCUMENT ARE NOT CONSIDERED SIGNED AND SEALED. THE SIGNATURE MUST BE VERIFIED ON ANY ELECTRONIC COPIES.

SOIL SURVEY, INC.
321 EAST 2ND STREET
TALLAHASSEE, FL 32301
LEIA I. CROSSWELL, P.E. NO. 99995

Exhibit 920-1
Soil Survey
Date: 1/1/2024

10/25/2023 7:54:16 AM RD960DL C:\Projects\standards\Roadway\FDM_900_Exhibit_Master.dgn

REVISIONS		PROFESSIONAL ENGINEER		STATE OF FLORIDA DEPARTMENT OF TRANSPORTATION			SHEET NO.
DATE	DESCRIPTION	DATE	DESCRIPTION	ROAD NO.	COUNTY	FINANCIAL PROJECT ID	
				SR 22	BAY	123456-1-52-01	GR-1

SOIL SURVEY

Exhibit 920-2
Report of Core Borings
Date: 1/1/2023

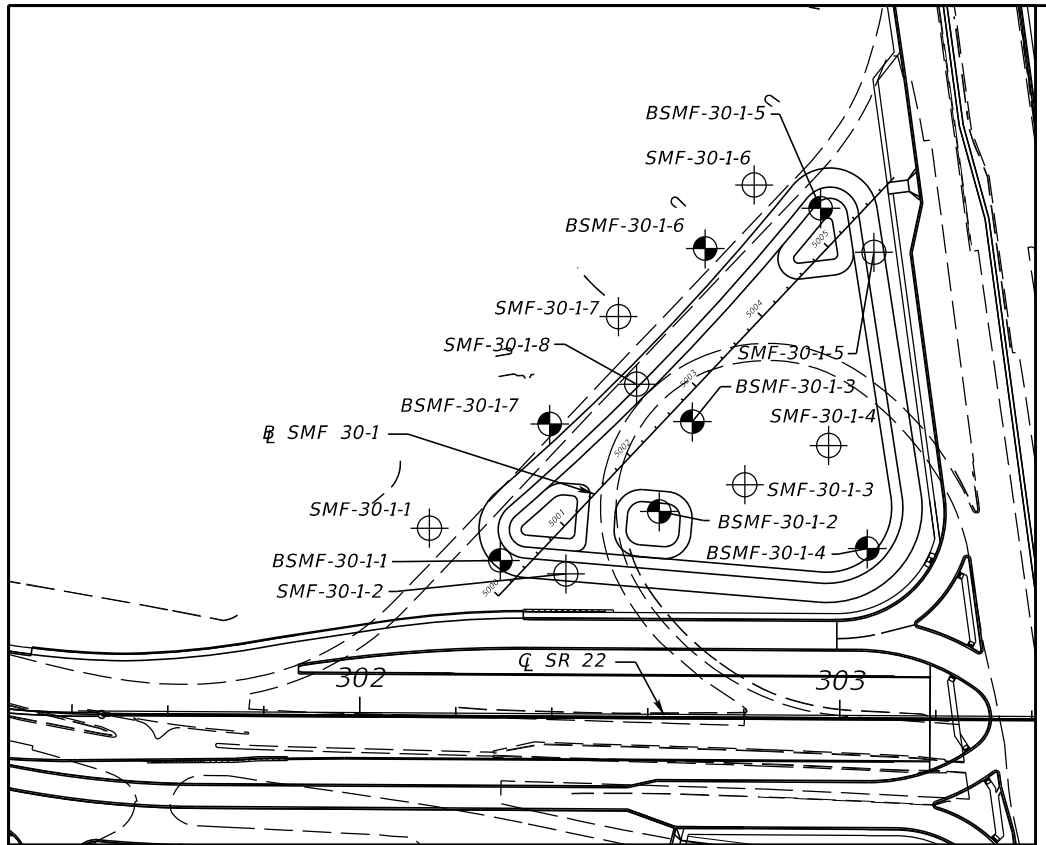

BORING LOCATION

LEGEND

1. GRAY TO BROWN SAND TO SAND WITH SILT (A-3)
 2. LIGHT BROWN TO BROWN SILTY SAND (A-2-4)
 3. LIGHT GRAY TO BROWN SILTY SAND TO CLAYEY SAND (A-2-4/A-2-6)
 4. DARK BROWN TO BLACK SAND TO SILTY SAND WITH ORGANIC MATERIAL (A-8)
 5. DARK BROWN SAND TO SILTY SAND WITH TRACE ORGANICS (A-3/A-2-4)
 6. GRAY CLAYEY SAND TO SANDY CLAY TO CLAY (A-6/A-7-6)
 7. GREEN TO BROWN CLAYEY SAND TO CLAY (A-7-5/A-7-6)
- A-3 AASHTO GROUP SYMBOL AS DETERMINED BY VISUAL REVIEW AND LABORATORY TESTING ON SELECTED SAMPLES FOR CONFIRMATION OF VISUAL REVIEW
- HA HAND AUGERED TO VERIFY UTILITY CLEARANCE
- 200 PERCENT PASSING #200 SIEVE
- NMC NATURAL MOISTURE CONTENT (%)
- LL LIQUID LIMIT (%)
- PI PLASTICITY INDEX (%)
- NGVD NATIONAL GEODETIC VERTICAL DATUM OF 1929
- ▼ GROUNDWATER LEVEL ENCOUNTERED DURING FIELD EXPLORATIONS
- ▽ ESTIMATED SEASONAL HIGH GROUND WATER TABLE
- GNE GROUNDWATER NOT ENCOUNTERED
- GNA GROUNDWATER NOT APPARENT DUE TO THE INTRODUCTION OF DRILLING FLUID.
- ⊙ APPROXIMATE SPT BORING LOCATION
- ⊕ APPROXIMATE AUGER BORING LOCATION

⊕ SR 22 CENTERLINE OF CONSTRUCTION OF SR 22
 ⊕ SMF 30-1 BASELINE OF CONSTRUCTION OF POND SMF-30-1

NOTE: THE LOCATIONS OF THE BORINGS WERE RECORDED IN THE FIELD BY SOIL SURVEY, INC. USING HAND-HELD GPS EQUIPMENT WITH A REPORTED ACCURACY OF ±10 FEET. THE LOCATIONS OBTAINED FROM THE GPS COORDINATES RECORDED BY SOIL SURVEY, INC. WERE UTILIZED IN CONJUNCTION WITH MICROSTATION DESIGN FILES TO OBTAIN STATION, OFFSET, AND ELEVATION.

BOR # SMF-30-1-1
 STA. 5000+02
 REF. ⊕ SMF 30-1
 OFF. 101' LT.
 ELEV. 122.5
 DATE 3/20/2017

BOR # BSMF-30-1-1
 STA. 5000+28
 REF. ⊕ SMF 30-1
 OFF. 24' LT.
 ELEV. 125.0
 DATE 4/5/2017
 DRILLER A. JACKSON
 HAMMER AUTOMATIC
 RIG D-25

BOR # BSMF-30-1-7
 STA. 5001+67
 REF. ⊕ SMF 30-1
 OFF. 84' LT.
 ELEV. 127.5
 DATE 4/5/2017
 DRILLER A. JACKSON
 HAMMER AUTOMATIC
 RIG D-25

BOR # SMF-30-1-2
 STA. 5000+64
 REF. ⊕ SMF 30-1
 OFF. 35' RT.
 ELEV. 125.1
 DATE 3/20/2017

BOR # SMF-30-1-7
 STA. 5002+97
 REF. ⊕ SMF 30-1
 OFF. 109' LT.
 ELEV. 125.9
 DATE 3/20/2017

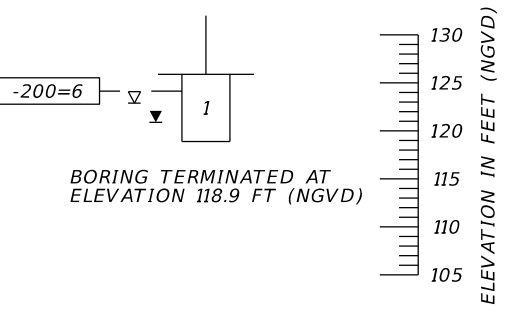
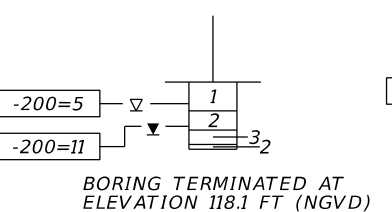
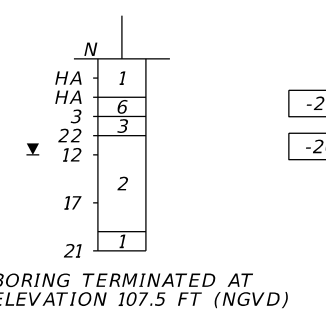
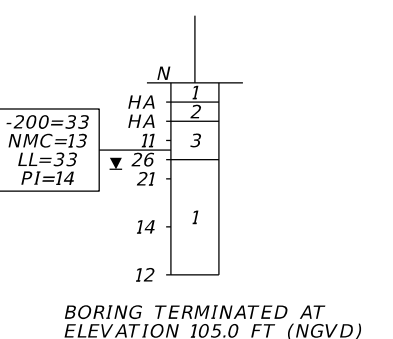
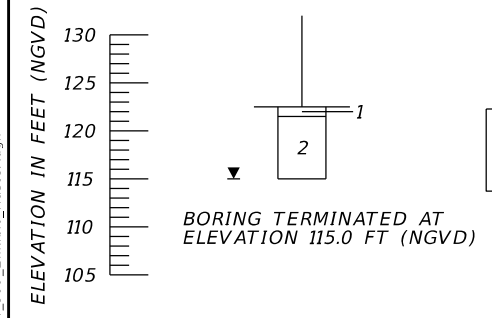

	SAFETY HAMMER	AUTOMATIC HAMMER
GRANULAR MATERIALS- RELATIVE DENSITY	SPT N-VALUE (BLOWS/FT.)	SPT N-VALUE (BLOWS/FT.)
VERY LOOSE	LESS THAN 4	LESS THAN 3
LOOSE	4 to 10	3 to 8
MEDIUM DENSE	10 to 30	8 to 24
DENSE	30 to 50	24 to 40
VERY DENSE	GREATER THAN 50	GREATER THAN 40
SILTS AND CLAYS CONSISTENCY	SPT N-VALUE (BLOWS/FT.)	SPT N-VALUE (BLOWS/FT.)
VERY SOFT	LESS THAN 2	LESS THAN 1
SOFT	2 to 4	1 to 3
FIRM	4 to 8	3 to 6
STIFF	8 to 15	6 to 12
VERY STIFF	15 to 30	12 to 24
HARD	GREATER THAN 30	GREATER THAN 24

SMF 30-1

11/9/2023 1:01:09 PM RD960DL C:\ProJects\standards\roadway\FDM_900_Exhibit_Master.dgn

REVISIONS		PROFESSIONAL ENGINEER		STATE OF FLORIDA DEPARTMENT OF TRANSPORTATION			REPORT OF CORE BORINGS POND #30	SHEET NO. GR-2
DATE	DESCRIPTION	DATE	DESCRIPTION	ROAD NO.	COUNTY	FINANCIAL PROJECT ID		
				SR 22	BAY	123456-1-52-01		

LEIA I. CROSSWELL, P.E.
 LICENSE NUMBER: 99995
 SOIL SURVEY, INC.
 321 EAST 2ND STREET
 TALLAHASSEE, FL 32301

THE OFFICIAL RECORD OF THIS SHEET IS THE ELECTRONIC FILE DIGITALLY SIGNED AND SEALED UNDER RULE 61G15-23.004, F.A.C.