

## 916 Drainage Structures Sheet

### 916.1 General

The signed and sealed Building Information Model (BIM) files contain the complete drainage system information for the project. The Drainage Structures sheet provides supplemental data and information for proposed drainage structures, including:

- (1) Drainage Plan View
- (2) Drainage Profiles
- (3) Drainage Tabular Information
- (4) Drainage Special Details and Notes
- (5) Optional Materials Tabulation

The Drainage Structures sheet is produced as a contract document and placed within the Roadway Plans. This sheet may be produced on a standard-format sheet (11"x17") or a large-format sheet (24"x36", 36"x48" or 36"x72"). Use landscape orientation regardless of sheet size selected. Sheet size selection should be based on size and extent of drainage network(s). The Drainage Structures sheet should display the complete extents of individual drainage network(s).

Use the following horizontal scales:

	<u>Standard</u>	<u>Optional</u>
Curbed Roadways	1" = 40'	1" = 50'
Flush-shoulder Roadways	1" = 50'	1" = 100'

Provide a legend for all abbreviations included in the drainage tabular information. See **Exhibit 916-1** for an illustration of the Drainage Structures sheet.

### 916.2 Drainage Plan View

The drainage plan view is typically shown in the upper half of the sheet. The purpose of this view is to highlight the storm drain network(s), cross drains, and side drains that will be shown in the profile views and included in the tabular data. The drainage plan view is not required when side drains are the only drainage structures included with the project,

however side drains must be shown and labeled on roadway plan sheet, and included in the drainage tabular information.

The display limits of the drainage plan view should contain the entire proposed drainage network. If multiple drainage networks are shown or overlap, clearly indicate which network the profile and tabular information is associated with.

## **916.2.1 Required Information**

Provide the following information in the plan view:

- (1) Display the view such that the centerline of construction or baseline of survey stationing is increasing from left to right. Display station numbers close to station ticks. Include a north arrow and scale above and near the drainage plan view.
- (2) Display proposed limits of pavement, curbs, traffic separators, sidewalks, curb ramps, and driveways. Show proposed bridges and approach slabs by simple outline and indicate the bridge structure number. The intent is to show an outline of the proposed roadway to give context to the location of the drainage structures. The elements of the proposed roadway should be gray scaled.
- (3) Display and label existing and proposed underground utilities only where a conflict exists. Identify the underground utility as a conflict node.
- (4) Display the proposed drainage system by depicting drainpipes with a single pipeline style indicating direction of flow, and the outline of inlets, manholes, junction boxes, and outfall features (e.g., MES, endwall).
- (5) Display and label existing structures that are to be filled, plugged, and remain in place.

Do not display existing topography, except to the extent those elements are to be incorporated into, affected by, or accommodated by the proposed drainage system. Existing topography elements may include roads, streets, driveways, buildings, underground and overhead utilities, walls, curbs, pavements, fences, railroads, bridges, drainage structures and similar items, as well as streams, ponds, lakes, wooded areas, ditches, existing gasoline storage tanks within limits of topographical survey, and other physical features. When shown, display existing topography elements as gray scaled.

## 916.2.2 Structure and Pipe Numbers

Provide drainage structure numbers (w/ prefix “S”), and a pipe number (w/ prefix “P”) between structures. Include the bridge number for proposed bridge culverts. Establish the structure and pipe numbers using the convention shown in **Exhibit 916-1** and described as follows:

- (1) **Storm drain networks:** Assign structure numbers in ascending order along the centerline of construction or baseline of construction. Assign pipe numbers that correlate with the structure at the hydraulically upper end of pipe.
- (2) **Cross drains and side drains:** Assign structure number in ascending order along the direction of flow (hydraulic upper end to lower end). Assign the same structure to intermediate or end structures with suffix letter (i.e., A, B, C). Assign pipe numbers to correlate with the structure at the hydraulically upper end of pipe. When there are multiple pipes associated with the cross drain or side drain include a suffix letter.

## 916.3 Drainage Profile

Drainage profiles are typically shown in the lower left portion of the sheet as illustrated in **Exhibit 916-1**. Stack or space the profiles to avoid overlapping of structures or notes. Display drainage profiles from left to right, beginning with the structure at the hydraulically upper end of the system run to the outfall or structure at the hydraulically lower end. All storm drain networks and cross drains are to be shown in profile view.

Do not include profile views for side drains.

Each drainage profile must include a background grid at the appropriate scale. Use the same horizontal scale for the profile portion that is used for the plan portion. The vertical scale is typically 10% of the horizontal scale (e.g., 1” = 50’ horizontal scale would typically use a 1” = 5’ vertical scale).

### 916.3.1 Required Information

Drainage profiles depict vertical relationships of the drainage network or cross drain along the centerline of the pipes. Provide the following information for each drainage profile:

- (1) Display drainage structures (typically depicted as rectangles) and connecting pipes. Place the outside edge of the first structure at the first vertical grid line as shown in **Exhibit 916-1**. Assign the value of zero to the first vertical grid line; subsequent vertical grid lines reflect the true distance along the pipe system.

- (2) Display and label wall zone pipes.
- (3) Label drainage pipes and structure numbers.
- (4) Display and label existing and proposed surfaces along centerline of pipe. Displaying surfaces past the limits of the first and last pipes is not required.
- (5) Provide horizontal grid line elevations along the left side of the background grid.
- (6) Display and label existing and proposed underground utilities. When appropriate, identify underground utility as a conflict node.

## **916.4 Drainage Tabular Information**

Drainage tabular information provides necessary data for the installation of structures and pipes associated with storm drain networks, cross drains, and side drains. The drainage tabular information is typically shown on the lower right portion of the sheet and consists of four tables:

- (1) Pipe Data
- (2) Structures Data
- (3) Endwall and MES Data
- (4) Optional Materials

If there is insufficient space on the Drainage Structures sheet, the Drainage Tabular Information may be placed on a separate sheet titled "Drainage Structures Data".

### **916.4.1 Pipe Data**

The Pipe Data table contains the following information:

- Pipe number, length, and size
- Hydraulic upper end structure number with invert elevation
- Hydraulic lower end structure number with elevation
- Optional materials group number

## 916.4.2 Structures Data

The Structure Data table contains the following information for each structure:

- Structure number
- Baseline feature
- Structure location (baseline station and offset)
- Structure type and bottom dimensions
- FDOT Standard Plans (Index 400 series) Notes
- Reference point elevation
- Pipe label for each pipe entering or exiting the structure

## 916.4.3 Endwall and MES Data

The Endwall and MES Data table contains the following information:

- Structure number
- Baseline feature
- Structure location (baseline station and offset)
- Structure type
- Pipe invert elevation
- Structure notes

## 916.4.4 Optional Materials

Modification for Non-Conventional Projects:

Delete **FDM 916.4.4** and see **Chapter 6** of the [Drainage Manual](#) for Optional Material requirements.

Consider optional materials for all pipes; however, match pipe extensions and end section replacements to the existing pipe material. See the Department's [Drainage Design Guide](#) (Optional Pipe Material Chapter) for more information.

Conduct an Optional Pipe Materials Analysis and place an Optional Materials table with the Drainage Tabular Information. The Optional Materials table shows all materials allowed and indicates which material is plotted in the plans and used as the basis for pay item quantities. The Optional Materials table is to include:

- Optional Pipe Group Number
- Size(s)
- Material, thickness or class, corrugation requirements, and protective coating
- Plotted and as-built notations, and construction remarks

## **916.5 Drainage Special Details**

Showing special horizontal or vertical details in the plans is typically not necessary. However, if it is determined that providing a special drainage detail is beneficial to conveying the design intent, the detail is typically placed in the upper right portion of the sheet but may be shown anywhere within available space on the sheet. Any scale may be used.

The following are examples of information that may be depicted:

- Clash detection results and utility clearances
- Drainage structure details (non-standard structures, pond outfall structures multiple or off-centered pipe connections to a structure wall)
- Isometric and 3D views with identifying labels

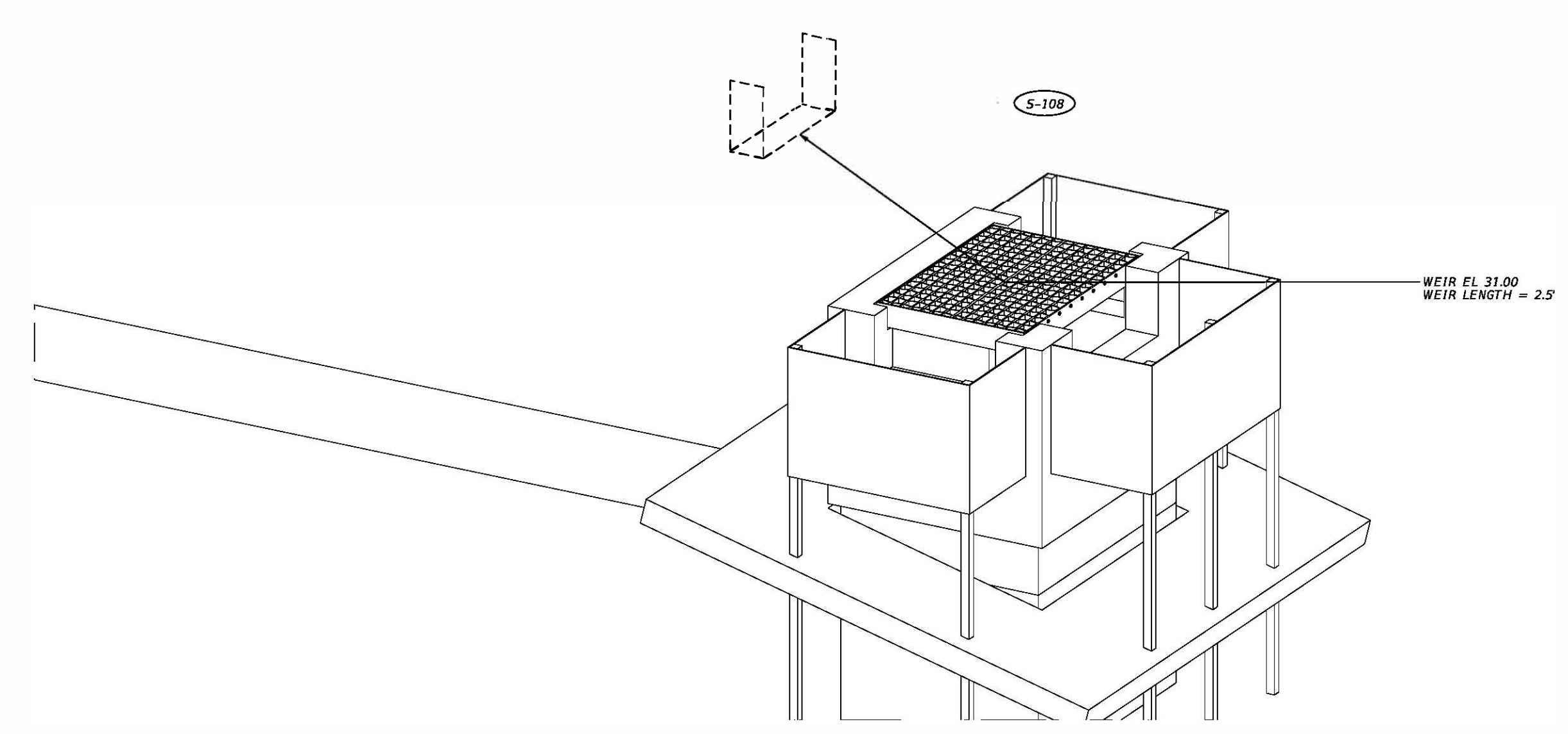
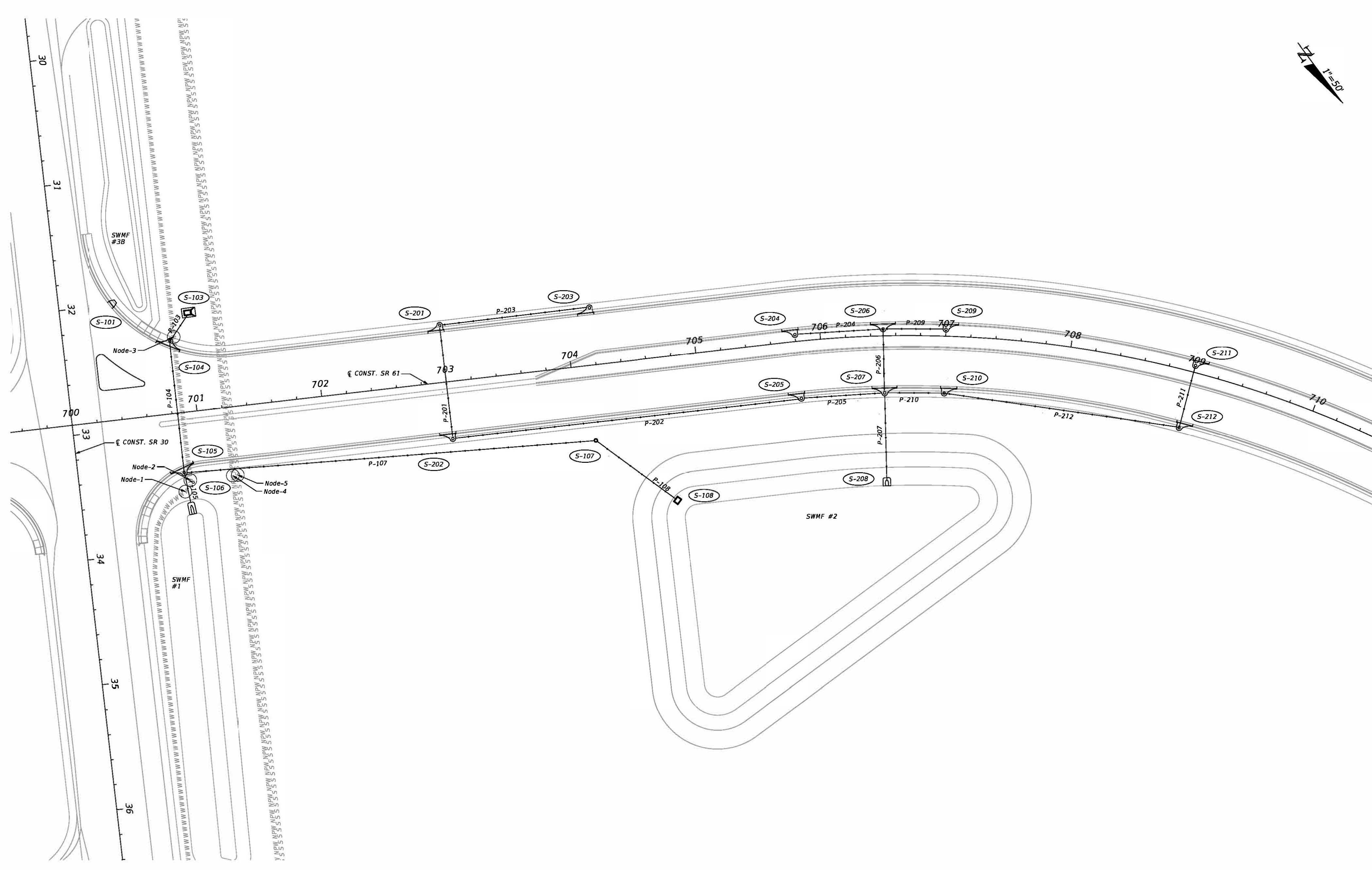

DETAIL S-108  
CONTROL STRUCTURE DETAILS

Utilities In Close Proximity To Drainage Features						
Label	Conflictee	Conflicter	Baseline Feature	Baseline Station (ft)	Baseline Offset (ft)	Notes
Node-1	8" WM	P-105	CL_SR61	700+83.58	57.63	2006796.65 402739.60
Node-2	8" WM	P-105	CL_SR61	700+88.60	56.49	2006717.29 402612.23
Node-3	8" WM	P-103	CL_SR61	700+88.60	-65.88	2006730.53 402635.15
Node-4	8" WPM	P-107	CL_SR61	701+21.55	49.05	2006788.05 402734.65
Node-5	12" SAN	P-107	CL_SR61	701+22.58	49.27	2006758.69 402751.86

Pipe Data							Optional Materials Tabulation							
Label	Barrels	Length (Construction) (ft)	Size	Start Node (Upper)	Start Invert (ft)	Stop Node (Lower)	Stop Invert (ft)	Optional Pipe	Group Number	Size(s)	Material	Plotted	As Built	Remarks
P-103	1	28	24 inch	S-103	29.50	S-104	29.00	Group 1	Group 1	18 - 24	RCP CLASS II	X		
P-104	1	103	24 inch	S-104	29.00	S-105	28.60	Group 1			SRAP, 16 GA.			
P-105	1	15	24 inch	S-105	28.60	S-106	28.50	Group 1			SRASP, 14 GA.			
P-107	1	334	14x23 inch	S-107	29.10	S-105	28.60	Group 4			SRASP, 14 GA.			
P-108	1	70	14x23 inch	S-108	29.20	S-107	29.10	Group 4			SRASP, 14 GA.			
P-201	1	87	18 inch	S-201	27.50	S-202	27.30	Group 1	Group 2	30	RCP CLASS II			
P-202	1	276	24 inch	S-202	26.80	S-205	26.20	Group 1			SRASP, 14 GA.			
P-203	1	116	18 inch	S-203	27.70	S-201	27.50	Group 1			SRASP, 14 GA.			
P-204	1	86	18 inch	S-204	26.70	S-206	26.60	Group 1	Group 3	18	RCP CLASS I	X		
P-205	1	62	24 inch	S-205	26.20	S-207	26.00	Group 1			HDPE CL II			
P-207	1	42	30 inch	S-207	25.50	S-208	25.00	Group 2			PVC ASTM F-949 PP			
P-209	1	46	18 inch	S-209	26.70	S-206	26.60	Group 1						
P-210	1	43	24 inch	S-210	26.30	S-207	26.00	Group 1						
P-211	1	47	18 inch	S-211	27.10	S-212	26.90	Group 3	Group 4	14x23	ERCP, CLASS II	X		
P-212	1	185	24 inch	S-212	26.40	S-210	26.20	Group 1						

Structure Data										
Label	Baseline Feature	Baseline Station (ft)	Baseline Offset (ft)	Structure Type	Bottom Dimensions	FDOT Standard Plans (400 index series) Notes	Remarks	Reference Point Elevation (ft)	Sump Elevation (Structure Invert) (ft)	-Pipe-Label
S-101	US98	32+02	-38.55	CLOSED FLUME				34.76	33.26	
S-103	CL_SR61	701+02	-83.90	DBI TYPE E		TRAVERSABLE INLET WITH SLOT EL 31.42		32.00	28.50	(In) P-103
S-104	CL_SR61	700+80	-54.04	CURB INLET TYPE 2	4 DIA.			34.71	28.00	(Out) P-103
S-105	CL_SR61	700+79	43.76	CURB INLET TYPE 2	4 DIA.		SEE DETAIL A	34.71	27.60	(Out) P-104
S-107	CL_SR61	704+19	51.15	MANHOLE TYPE B	3.5' DIA.			32.63	28.10	(In) P-107
S-108	CL_SR61	704+69	97.32	DBI TYPE D		NON-TRAVERSABLE INLET	SEE DETAIL B	32.00	28.20	(In) P-108
S-201	CL_SR61	703+00	-40.00	CURB INLET TYPE 1	4 DIA.			32.40	26.50	(Out) P-201
S-202	CL_SR61	703+00	40.00	CURB INLET TYPE 1	4 DIA.			32.40	25.80	(In) P-201
S-203	CL_SR61	704+20	-40.00	CURB INLET TYPE 1	4 DIA.			31.90	26.70	(Out) P-203
S-204	CL_SR61	705+80	-11.00	CURB INLET TYPE 1	4 DIA.			31.98	25.70	(Out) P-204
S-205	CL_SR61	705+80	40.00	CURB INLET TYPE 1	4 DIA.			31.00	25.20	(In) P-202
S-206	CL_SR61	706+50	-11.00	CURB INLET TYPE 2	4 DIA.			32.07	25.10	(Out) P-205
S-207	CL_SR61	706+50	40.00	CURB INLET TYPE 2	4 x 4			30.85	24.50	(In) P-204
S-209	CL_SR61	707+00	-11.00	CURB INLET TYPE 1	4 DIA.			32.15	25.70	(In) P-205
S-210	CL_SR61	707+00	40.00	CURB INLET TYPE 1	4 DIA.			30.93	25.20	(Out) P-206
S-211	CL_SR61	709+00	-11.00	CURB INLET TYPE 1	4 DIA.			33.94	26.10	(In) P-207
S-212	CL_SR61	709+00	40.00	CURB INLET TYPE 1	4 DIA.			32.72	25.40	(Out) P-209

Endwall and MES Data						
Label	Baseline Feature	Baseline Station (ft)	Baseline Offset (ft)	Structure Type	Elevation (Invert) (ft)	Remarks
S-106	CL_SR61	700+87	69.15	CD MES 1-4	28.50	
S-208	CL_SR61	706+50	102.50	CD MES 1-2	25.00	

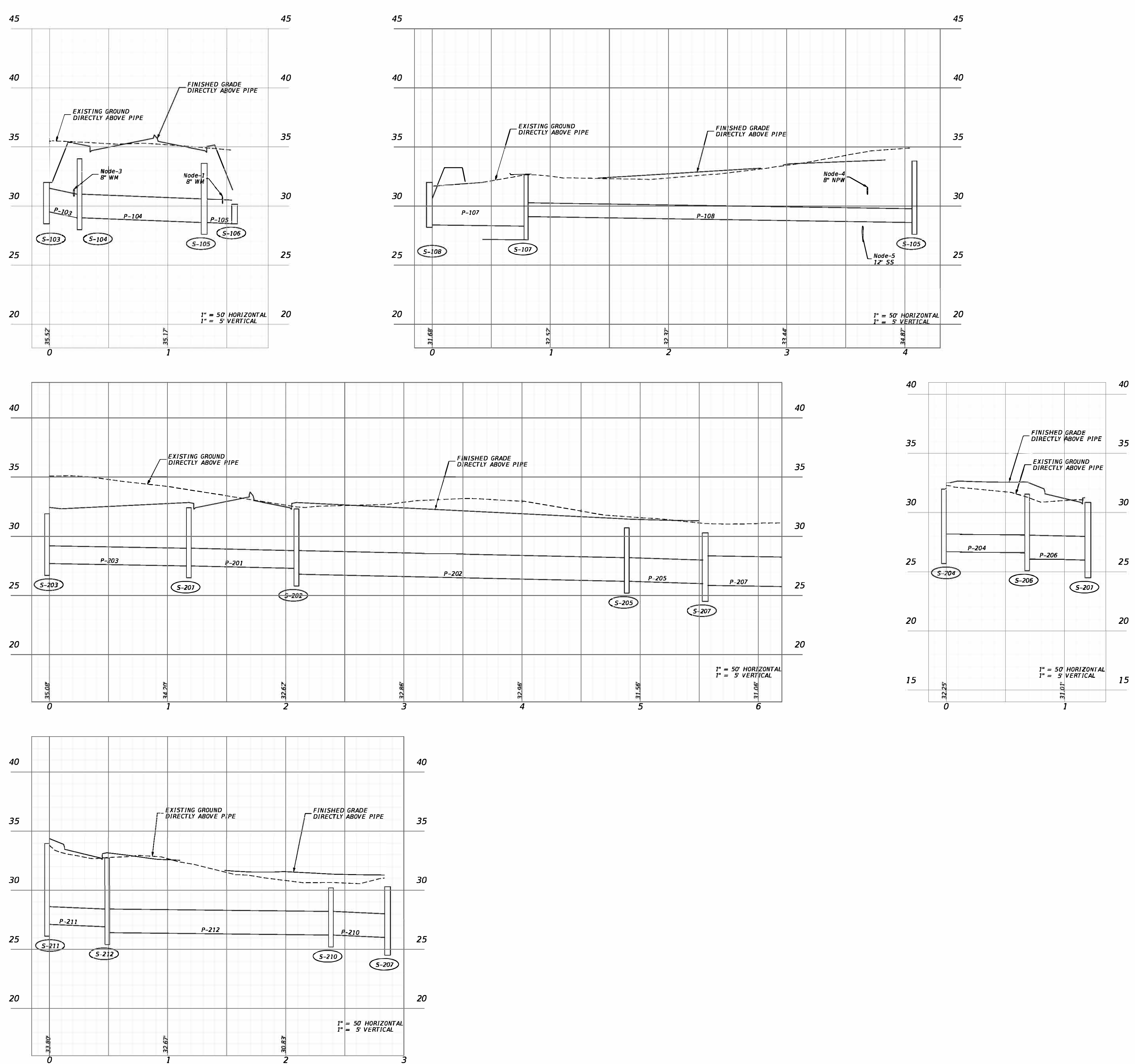

Exhibit 916-1  
Drainage Structures  
Date: 1/1/2024