

201 Design Controls

201.1 General

Designs for highway and bridge projects are based on established design controls for the various elements of the project such as width of roadway, side slopes, horizontal and vertical alignment, drainage considerations and intersecting roads. Selection of the appropriate criteria and standards is influenced by traffic volume and composition, desired levels of service, functional classification, terrain features, context classification, and environmental considerations.

The identification of applicable design controls is needed to achieve:

- (1) Optimum safety.
- (2) Desired capacity and Level of Service.
- (3) Design consistency.
- (4) Cost effective designs.

201.1.1 Capacity and Level of Service

The AASHTO publication *A Policy on Geometric Design of Highways and Streets*, the Transportation Research Board *Highway Capacity Manual*, and FDOT's [Quality/Level of Service \(Q/LOS\) Handbook](#) provide detailed analysis and calculation procedures used in determining the number and configuration of lanes required and the resulting levels of service provided. As illustrated in those texts the following factors greatly influence capacity and Level of Service:

- Roadway gradients and roadside developments
- Number, spacing, and types of crossings and intersections
- Traffic volumes and composition
- Signalization progression and interconnectivity

Design of signalized intersections should ensure an adequate Level of Service through the design year of the facility, especially when right of way acquisition is being considered. The capacity of an at-grade arterial or collector is primarily controlled by its ability to move traffic through signalized intersections, rather than the mid-block through lane capacity.

Use the operational analysis methods in the Highway Capacity Manual for design of signalized intersections. Information or assumptions on basic intersection geometrics, lane utilization, and movement-specific traffic volumes are provided by the designer. The primary output of the operational analysis method is Level of Service and delay at a signalized intersection; however, this method can be used to determine geometric requirements, signal timing, or service flow volumes.

Signal timing is interactive with geometric design. Changes to geometrics, such as adding a turn lane, must consider changes to the signal timing simultaneously. Department-approved software, including the Highway Capacity Software, should be used to simulate the operation of independent or interconnected signals. Output from these programs can be used for the analysis and evaluation of proposed designs.

201.1.2 Design Consistency

Design consistency is achieved when the geometric features of the roadway are consistent with the operational characteristics expected by the driver. Design consistency alleviates driver uncertainty and inappropriate driver response. Following the criteria contained in this manual will assure design consistency; however, special attention should be given at locations where sudden changes in Design Speed, alignment or cross section occur, and in the development of intersection designs.

Roadways may traverse through a variety of context classifications. As the context changes, the Design Speed for the roadway will also change. Changes in Design Speed may also occur based on FDOT policy or to conform to operational or geometric conditions. Consistent signing and pavement marking designs in transition areas is an important aspect in meeting driver expectancy. See **FDM 201.5** for information on Design Speed.

Two examples of sudden change in cross section are where a narrow bridge exists and when the number of travel lanes increase or decrease. The FDOT [Standard Plans](#) provide guidance on accepted practices in these areas. Changes in the cross section may also occur when there is a change in the context classification.

Critical design elements that affect design consistency, driver expectancy, and vehicular operation include:

- Horizontal and vertical alignment
- Embankments, slopes, and guardrail applications
- Bridge width and roadway shoulders
- Pavement crown, cross slope, and superelevation

- Signing and delineation
- Placement of signal, lighting, and utility poles

201.2 Context Classification

Context classification is a design control that determines key design criteria elements for arterials and collectors. Criteria for LA Facilities are independent of the adjacent land uses; therefore, context classifications do not apply to these facilities and they are assigned the code “LA” for “Limited Access” where a context classification is required, such as in the Roadway Characteristics Inventory. However, where a limited access facility connects to the non-limited access state road system, the context classification of the non-limited access facility must be considered to provide a context-appropriate transition between access classifications. Each state road has been assigned a context classification, and this information can be obtained from the District Complete Streets Coordinator. The following is a list of the Department’s adopted context classifications:

- C1 – Natural
- C2 – Rural
- C2T – Rural Town
- C3R – Suburban Residential
- C3C – Suburban Commercial
- C4 – Urban General
- C5 – Urban Center
- C6 – Urban Core

Additional information on context classification is included in **FDM 200**. Contact the District Complete Streets Coordinator to obtain the appropriate context classification for project roadway segments.

201.3 Traffic and Design Year

To provide for an interconnected transportation system that insures the mobility of people and goods, designs should satisfy capacity needs at an acceptable level of service through the design year. Forecasted traffic demand and volume are used to establish the number of travel and turn lanes, turn lane storage, signal timing, and right of way requirements. Forecasted traffic should account for anticipated future land use development.

The design year is the year for which the proposed improvement is designed. The FDOT **Project Traffic Forecasting Handbook** states that the design year is usually 20 years from the Opening Year, but design period may range in years from the present to 20 years depending on the project type.

Design year period typically used on FDOT projects are as follows:

- 20 years for new construction and reconstruction projects
- 15 years for lighting projects
- 10 years for signalization projects
- 10 years for improvements included with RRR projects
- 0-10 years for safety and operational improvements

Traffic forecasting is also used in pavement design to determine the vehicular loadings on the pavement. The proposed pavement design must provide structural strength through the pavement's service life. Refer to the FDOT [Pavement Design Manuals](#) for guidance on selecting an appropriate design period for flexible and rigid pavements.

Traffic forecasts are developed during the Project Development and Environmental (PD&E) study of a project. A Project Traffic Analysis Report is generally required. When a PD&E study is not conducted, traffic forecasts must be prepared early in the design phase. Project traffic used for design must be attested to by completing **Form 130b**, located in **FDM 103**.

Traffic data used for design includes:

- (1) AADT for the current year, opening year and design year.
- (2) Existing hourly traffic volumes over minimum of 24-hour period, including peak hour turning movements and pedestrian counts.
- (3) Directional distribution factor (D).
- (4) Standard K factor (K).
- (5) Truck factors (T) for daily and peak hour.
- (6) Design Speed and proposed Posted Speed.
- (7) Design vehicle for geometric design.
- (8) Peak turning movements at signalized and problem intersections and major traffic generators.
- (9) Movements for future traffic generators that are scheduled during the service life should be considered.

201.4 Access Management

Regulation of access is necessary to preserve the functional integrity of the State Highway System and to promote the safe and efficient movement of people and goods within the state. Under **Florida Statutes 335.18**, the Legislature authorized FDOT to develop rules to administer the "State Highway System Access Management Act". These are **Rule 14-96** and **Rule 14-97**; see **Tables 201.4.1, 201.4.2** and **201.4.3**. Designs are to comply with the statute, the rules, adopted procedures and directives, and the district program.

Table 201.4.1 Rule 14-97 - Freeway Interchange Spacing

Access Class	Area Type	Segment Location	Interchange Spacing (miles)
1	Area Type 1	CBD & CBD Fringe For Cities In Urbanized Areas	1.0
	Area Type 2	Existing Urbanized Areas Other Than Area Type 1	2.0
	Area Type 3	Transitioning Urbanized Areas, and Urban Areas Other Than Area Type 1 or 2	3.0
	Area Type 4	Rural Areas	6.0

Table 201.4.2 Rule 14-97 - Arterial Access Classifications & Standards

Access Class	Median Type	Connection Spacing (feet)		Median Opening Spacing (feet)		Signal Spacing (feet)
		>45 mph	≤45 mph	Directional	Full	
2	Restrictive with Service Roads	1320	660	1320	2640	2640
3	Restrictive	660	440	1320	2640	2640
4	Non-Restrictive	660	440			2640
5	Restrictive	440	245	660	2640 >45 mph 1320 ≤ 45 mph	
6	Non-Restrictive	440	245			1320
7	Both Median Types	125		330	660	1320

Notes:

- (1) "Restrictive" physically prevent vehicle crossing.
- (2) "Non-Restrictive" allow turns across at any point.
- (3) Speeds shown in this table are posted speeds.

Interchange Ramp Areas:

Connections within the interchange ramp area require the following spacing from the end of the ramp taper:

- 440 feet ≤ 45 mph
- 660 feet > 45 mph
- 1,320 feet on Access Class 2 Facilities > 45 mph

Median openings within the interchange ramp area require the following standard distance from the end of the ramp taper:

- 2,640 feet for full median opening
- 1,320 feet for directional median opening

Table 201.4.3 Rule 14-97 - Interim Access Management Standards

Posted Speed (mph)	Connection Spacing (feet)	Median Opening Spacing (feet)		Signal Spacing (feet)
		Directional	Full	
35 mph or less	245	660	1320	1320
36 - 45 mph	440	660	1320	1320
Over 45 mph	660	1320	2640	1320

In addition, FDOT adopted the ***Median Opening and Access Management Decision Process (Topic No. 625-010-021)***, which further defines the principles and processes for FDOT to implement the Access Management Statute and Rules.

Each district has established an Access Management Review Committee to guide actions in access management and median decisions through all FDOT’s processes. Various district offices are responsible for driveway permit connections and administering other parts of the program.

Each roadway on the State Highway System is assigned an access classification which determines what roadway features and access connection modifications are appropriate to adhere to the program.

During the PD&E phase, a conceptual access management plan is prepared for the preferred alternative. Access management issues are addressed in the Preliminary Engineering Report. Designs are to implement access management decisions and commitments made during the PD&E phase.

For projects that did not go through a PD&E phase, access connections within the project limits are to be evaluated for compliance with the assigned access classification. Driveways, signal, and median opening spacing should be considered in the analysis of safety and operational problems. Modifications or closures to access may be the solution in certain cases.

Rule 14-97.003(3)(b) gives FDOT the authority to alter, relocate or replace connections in order to meet current FDOT standards.

Rule 14-96.011 allows FDOT to revoke a permit "...if the connection causes a safety or operational problem on the State Highway System substantiated by an engineering study...".

Rule 14-97.003(3)(b) provides guidance on the treatment of existing features in the highway improvement process:

“Existing lawful connections, median openings, and signals are not required to meet the access management standards. Existing access management features will generally be allowed to remain in place, but shall be brought into conformance with access management standards when significant change occurs or as changes to the roadway design allow.”

Where revisions are necessary due to operational or safety problems, it may not be possible to upgrade a median opening or driveway connection to the current standards because of existing conditions or constraints. In these cases, provide the best solution, based on good engineering practice.

Median Opening and Access Management Decision Process (Topic No. 625-010-021) requires the following:

- (1) Any significant change to driveway access will be shown in the plans or the driveway will be replaced in the same location, width and configuration (number of lanes).
- (2) Access design and impacts to a right of way acquisition parcel should be determined prior to the right of way phase.
- (3) Changes to access details or decisions must be coordinated with District Right of Way and General Counsel’s offices in addition to the Access Management Review Committee.

Properties that abut a roadway on the State Highway System has a right to reasonable access to the roadway. A means of reasonable access cannot be denied except on the basis of safety and operational concerns as provided in **Section 335.184, Florida Statutes**. Nothing in **Section 335.184** limits FDOT's authority to restrict the operational characteristics of a particular means of access. Service roads provide reasonable access.

It should be noted that if there are any conflicts between this manual and the statute and rules, the statute and rules will govern.

201.5 Design Speed

Design Speed is a principal design control that regulates the selection of many of the project standards and criteria used for design. The selection of an appropriate Design

Speed must consider many factors. The AASHTO publication, ***A Policy on Geometric Design of Highways and Streets***, has a thorough discussion on Design Speed.

There are three categories of Design Speed:

High Speed: Design Speeds 50 mph and greater.

Low Speed: Design Speeds of 45 mph and less.

Very Low Speed: Design Speeds 35 mph and less.

201.5.1 Design Speed Selection

Design Speed should be selected early in the design process and should reflect the Target Speed (see below). Select a context-appropriate Design Speed to attain a desired degree of safety, mobility, and efficiency. Where the initial recommended Target Speed value is not feasible to attain in a single project, the Target Speed should be as close to the initial Target Speed values as can be achieved within the constraints of the project. Adjust both the Design Speed and Target Speed as appropriate to achieve a single value appropriate to the project. Select Design Speeds in increments of 5 mph.

Target Speed is the highest speed at which vehicles should operate on a thoroughfare in a specific context, consistent with the level of multi-modal activity generated by adjacent land uses, to provide both mobility for motor vehicles and a supportive environment for pedestrians, bicyclists, and public transit users. Determine appropriate Target Speed for all non-limited access projects where a Design Speed is also required. The Target Speed must:

- Be within the range of Design Speeds for the context classification (see ***Table 201.5.1***),
- Reflect the needs of safety, quality of life, and economic development of the corridor, and
- Be established by a team that includes, but is not limited to, Design, Traffic Operations, Safety, Planning, and Program Management offices.

It is expected that initial Target Speed values may be modified during project scoping to achieve the Target Speed as additional information is gathered and project scoping decisions are made. See the ***FDOT Context Classification Guide*** for more information about determining appropriate Target Speed.

In general, the Target Speed for C1 and C2 roadways should be on the higher end of the Design Speed range, with justification provided for lower speeds. In C2T through C6,

consider starting with Target Speeds on the lower end of the range with justification provided for higher speeds.

It is considered a best practice to provide initial Target Speed values as part of the Context Classification determination. These initial values can be an effective starting point for the establishment of the Target Speed. For RRR projects where the initial Target Speed value is below the existing Design Speed or Posted Speed Limit, see **FDM 202** for Speed Management techniques to better align the Design Speed with Target Speed. In many cases, the Design Speed and the initial Target Speed values may both need to be changed to arrive at a Target Speed appropriate for the project.

*Commentary: The 85th-percentile observed speed is a starting point when traffic engineers conduct a speed study for setting speed limits (see the **FDOT Speed Zoning Manual** for more information, if desired.). The 85th percentile speed should be considered when selecting the Target Speed, but the Target Speed does not have to match the 85th-percentile speed.*

In many cases, speed management is required because the existing 85th-percentile speed is too high for current conditions, so setting Target Speed equal to the existing 85th-percentile speed would fail to accomplish the speed management objectives. The primary value of knowing the existing 85th percentile speed is to understand the potential magnitude of speed management interventions that may be required to achieve a selected Target Speed. Large speed reductions of more than 10 mph, for instance, may need to be approached incrementally over several projects, rather than achieved at once on a single project.

The District Design Engineer (DDE) and the District Traffic Operations Engineer (DTOE) jointly approve the selected Design and Posted Speeds. This approval is a declaration that the Posted Speed will not exceed the selected Design Speed. This is to be documented on the Typical Section Package as described in **FDM 120.2.3**.

Table 201.5.1 provides an allowable range of mainline Design Speeds on the State Highway System. **Table 201.5.2** provides the minimum Design Speeds allowed on ramps.

Modification for Non-Conventional Projects:
See RFP for Design Speed and Target Speed.

Table 201.5.1 Design Speed

Limited Access Facilities (Interstates, Freeways, and Expressways)		
Area	Allowable Range (mph)	SIS Minimum (mph)
Rural and Urban	70	70
Urbanized	50-70	60
Arterials and Collectors		
Context Classification	Allowable Range (mph)	SIS Minimum (mph)
C1 Natural	55-70	65
C2 Rural	55-70	65
C2T Rural Town	25-45	40
C3 Suburban	35-55	50
C4 Urban General	25-45	45
C5 Urban Center	25-35	-
C6 Urban Core	25-30	-
Notes: <ol style="list-style-type: none"> (1) SIS Minimum Design Speed may be reduced to 35 mph for C2T Context Classification when appropriate design elements are included to support the 35-mph speed, such as on-street parking. (2) SIS Minimum Design Speed may be reduced to 45 mph for curbed roadways within C3 Context Classification. (3) For SIS facilities on the State Highway System, a selected Design Speed less than the SIS Minimum Design Speed requires a Design Variation as outlined in SIS Procedure (Topic No. 525-030-260). (4) For SIS facilities not on the State Highway System, a selected Design Speed less than the SIS Minimum Design Speed may be approved by the District Design Engineer following a review by the District Planning (Intermodal Systems Development) Manager. (5) SIS minimum Design Speed may be reduced to 30 mph for C2T, C3, and C4 for facilities with a transit route. 		

Table 201.5.2 Ramp Design Speeds

Ramp Connection Type	Minimum Design Speed (mph)
Loops and Semi-Direct	30
Outer Cloverleaf	35
Intermediate Portions of Long Ramps	40
Direct Connection	50
<p><u>Express Lane Direct Connections:</u></p> <p>(1) Design Speeds higher than the minimum shown above should be used when practical. A Design Speed of 60 mph is desirable.</p> <p>(2) Design Variations for Design Speed will not be approved for Express Lane Direct Connections with a Design Speed below 40 mph.</p>	

201.5.1.1 Collector-Distributor Roads

The Design Speed for collector-distributor roads must not be more than 10 mph below the Design Speed of the primary facility when direct ingress or egress to the Limited Access facility is provided. C-D road segments more than one intersection away from a LA facility should be assigned a Target Speed in accordance with their context classification.

201.5.1.2 Express Lanes

Express lanes Design Speed will be the same Design Speed as the adjacent general use lanes or general toll lanes in roadways that have buffer and wide buffer separation. In cases of barrier and grade separation the Design Speed can be equal to or greater than that of the adjacent general use lanes or general toll lanes, but never less than the general use lanes or general toll lanes. Minimum ramp Design Speeds for Express Lanes ramps are included in **Table 201.5.2**.

201.5.2 Post-Construction Speed Study

The District Traffic Operations Engineer (DTOE) typically conducts a speed investigation within one year after a new construction or reconstruction project is completed. A change in Posted Speed limit may be proposed based on engineering and traffic investigations

described in the Department's *Manual on Speed Zoning for Highways, Roads and Streets in Florida* (a.k.a. [Speed Zoning Manual](#)).

When a speed study indicates that a higher Posted Speed is warranted, a modification of Posted Speed limit may be made under the authority of the District Traffic Operations Engineer (per the Traffic Regulation Approval Process, [FDOT Procedure No. 750-010-011](#)).

To assign a Posted Speed higher than the Design Speed, the DTOE, working with the District Design Engineer (DDE) must process a Design Exception or Design Variation for each design element that does not meet the criteria for the higher speed.

Further explanation on how Posted Speed limits are developed can also be found on the State Traffic Operations web page:

<https://www.fdot.gov/traffic/FAQs/>

201.5.3 RRR Projects

Select a Design Speed consistent with the Target Speed (see *FDM 201.5.1*), context classification of the roadway and project scope. The Design Speed used for a RRR project must be no higher than the Design Speed used in the original design of the highway.

When the Posted Speed is greater than the Design Speed used in the original design of the highway:

- (1) Process a Design Variation or Design Exception for each design element that does not meet the criteria for the higher Posted Speed. Refer to Design Variations and Design Exceptions that were processed when the higher Posted Speed was implemented.
- (2) Use criteria based on the Posted Speed:
 - (a) when correcting a specific highway feature that has a significant crash history
 - (b) for any new highway feature
- (3) For replacement of highway features, use criteria based on the Posted Speed to the greatest extent possible, but not less than the Design Speed.

When the Design Speed used in the original design of the highway is higher than the existing Posted Speed, the Design Speed may be reduced to match the existing Posted Speed, as long as the values in *Table 201.5.1* are still met. Speed management

strategies (per **FDM 202**) should be used in conjunction with reduction of Design Speed. No Design Variation is required to lower the Design Speed to match the existing Posted Speed.

Include Design Speed, Target Speed, Design Variations, and Design Exceptions in the Typical Section Package. See **FDM 120.2.3**.

If the existing Design Speed or Posted Speed meets AASHTO's criteria but is not within the allowable range shown in **Table 201.5.1**, a Design Variation is not required to maintain the existing Design or Posted Speed. When Posted Speed exceeds the allowable range, roadway elements that encourage lower operating speeds should be included with the project. See **FDM 202** for examples of roadway elements that encourage lower operating speeds.

201.6 Design Vehicle

The Design Vehicle is the largest vehicle that is accommodated without encroachment on to curbs (when present) or into adjacent travel lanes. The type of Design Vehicle is influenced by the functional and context classification of a roadway, the role of the roadway in the network, and the land uses served.

The selected Design Vehicle affects:

- Horizontal and vertical alignments
- Lane widths and lane assignments
- Roundabout inscribed circle diameter
- Intersection turning radii and sight distance
- Auxiliary lane storage length, and acceleration and deceleration lengths

When considering dual left turn or right turn lanes, the Design Vehicle should generally be considered as turning simultaneously with a passenger car.

AASHTO's A Policy on Geometric Design of Highways and Streets provides general guidance on the selection of a design vehicle. **AASHTO** also provides the dimensions and turning characteristics for a variety of standard design vehicles; e.g., P, SU, WB-40, WB-62.

Florida Statutes allow truck-trailer combinations that are similar to the AASHTO WB-62 Interstate Semitrailer with some slight modifications. This modified WB-62 design vehicle is defined as the Florida Interstate Semitrailer (WB-62FL) and is often used as the design

vehicle on the SHS. In addition, the Florida's Turnpike and other truck routes allow tandem tractor trailers. Use the AASHTO WB-109D as the design vehicle for tandem truck routes.

201.6.1 Control Vehicle

The Control Vehicle is one that is infrequent and is accommodated by allowing:

- Encroachment into opposing lanes if no raised median is present
- Minor encroachment on to curbs and areas within the curb return if no critical infrastructure such as traffic signal poles are present.

Control Vehicles may be appropriate at intersections for curbed roadways within C4, C5 and C6 context classifications. When considering U-turns, the Control Vehicle may be used as the Design Vehicle.

201.6.2 WB-62FL

When designing for a WB-62FL at intersections, the design elements (e.g., control radii, return radii) can be based on the criteria tables and figures in **AASHTO** for a WB-62. In addition, when designing features for complex or constrained intersections (e.g., roundabouts, multi-lane turns, directional median openings, ramps) the geometric design elements should be checked against the turning movement of a WB-62FL. The Florida Interstate Semitrailer WB-62FL is illustrated in **Figure 201.6.1**.

Figure 201.6.1 WB-62FL

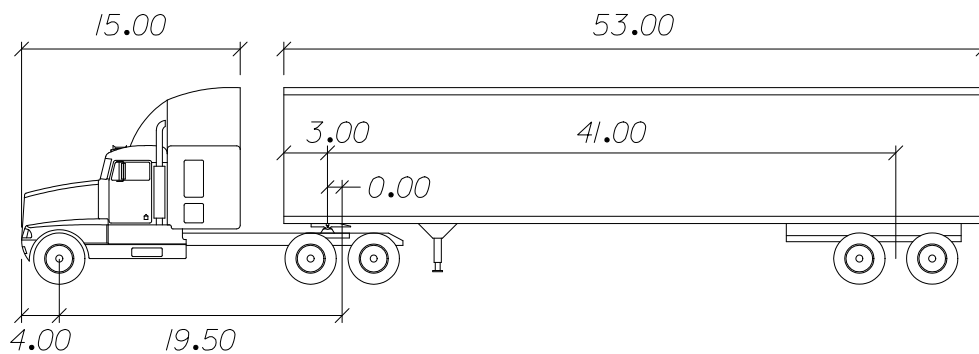

<i>WB-62FL</i>		<i>feet</i>	
<i>Tractor Width :</i>	<i>8.00</i>		<i>Lock to Lock Time: 6.00 seconds</i>
<i>Trailer Width :</i>	<i>8.50</i>		<i>Steering Angle : 28.40 degrees</i>
<i>Tractor Track :</i>	<i>8.00</i>		<i>Articulating Angle: 70.00 degrees</i>
<i>Trailer Track :</i>	<i>8.50</i>		