

## 230 Signing and Pavement Marking

### 230.1 General

Traffic control devices are necessary to help ensure highway safety. Traffic control devices provide for an orderly and predictable movement of motorized and non-motorized traffic throughout the highway transportation system. They also provide guidance and warnings to ensure the safe and informed operation of individual elements of the traffic stream. The design and layout of signs and pavement markings should complement the basic highway design.

FHWA's [Manual on Uniform Traffic Control Devices \(MUTCD\)](#) contains detailed information of all standard highway signs and pavement marking messages. Each sign is identified by a unique designation. Signs and pavement markings not included in the [MUTCD](#) or in the [Standard Plans](#) are to be detailed in the plans. Sign and pavement marking design must comply with [Standard Specifications](#), [Standard Plans](#), [TEM](#), [MUTS](#), and the [MUTCD](#).

Examples of typical signing and pavement marking configurations are included in **FDM 230.6**.

#### 230.1.1 Structural Supports

AASHTO's *LRFD Specifications for Structural Supports for Highway Signs, Luminaires, and Traffic Signals* and [FDOT Modifications to LRFDLTS-1](#) provide structural design criteria.

Refer to **FDM 261** for information regarding structural support requirements. Refer to **FDM 940** for information regarding plan requirements.

#### 230.1.2 School Zones

The Department's *Manual on Speed Zoning for Highways, Roads and Streets in Florida* (a.k.a., [Speed Zoning Manual](#)), **Chapter 15**, provides school zone signing and pavement marking requirements.

Public or private elementary, middle schools (Jr. High), and federally funded facilities providing a full-time educational program are to comply with the pavement markings, signs, and other traffic control devices referenced in the [Speed Zoning Manual](#). The use of these devices at high schools must be justified by an engineering study.

[Standard Plans](#), *Index 700-120* provides details relating to enhanced highway signing assemblies.

### **230.1.3 Vertical Clearance**

See *FDM 210.10.3* for vertical clearance requirements for sign structures.

## **230.2 Signing**

### **230.2.1 Sign Placement**

Refer to the [MUTCD](#), [Standard Plans](#), and *FDM 215* for acceptable sign locations. Provide a four-foot clear width, not including the width of curb, when a sign is located within a sidewalk.

#### **230.2.1.1 Advance Guide Signs for Limited Access Facilities**

Use physical gore as the point of reference to measure distance for advance guide sign messages when the physical gore and theoretical gore are separated by no more than 500 feet.

#### **230.2.2 Overhead Signs on Limited Access Facilities**

*Section 2A.17* of the [MUTCD](#) lists thirteen optional conditions where overhead signs have value on limited access facilities. Signs are to be ground mounted except at locations required by the [MUTCD](#) or noted below:

Use overhead exit direction signs when any of the following conditions exists:

- (1) Interchange Spacing  $\leq$  3 Miles
- (2) Left Exit
- (3) Three or More Through Lanes

Use overhead advance guide signs when any of the following conditions exists:

- (1) Interchange Spacing  $\leq$  3 Miles
- (2) Left Exit

- (3) Limited access facility to limited access facility Interchange (1/2 mile and 2 mile, 1 mile required by [MUTCD](#))

This criteria is not intended to restrict the use of overhead signs where there is insufficient space for post mounted signs or where there is restricted sight distance.

Place overhead advance guide signs over the shoulder with the edge of the sign aligned with the edge of the traveled way unless otherwise shown in the [MUTCD](#). Place overhead exit signs over the ramp traffic lane(s). If a barrier is present to shield another hazard, place the upright behind the barrier with proper setback for barrier performance.

### **230.2.3 Local Street Names on Guide Signs**

Standard practice is to use route numbers on guide signs to designate roadways. When the local name for a roadway is more familiar than the route number, the local street name may be used as supplemental information to route numbers. The decision to use a local name should be coordinated with the District Traffic Operations Engineer.

### **230.2.4 External Lighting of Overhead Signs**

Provide external lighting of overhead signs only for the following conditions:

- (1) Horizontal curves with radii of 880 feet or less in rural context classifications.
- (2) Horizontal curves with radii of 2,500 feet or less in urban context classifications.
- (3) In sag vertical curves with a K value of 60 or less for all context classifications.

Show sign lighting requirements on the Guide Sign Worksheet when sign lighting is required. Include sign lighting calculations in the Lighting Design Analysis Report.

To eliminate the use of lighting on existing overhead sign structures, confirm all panels on the structure utilize Type XI sheeting. All panels not utilizing Type XI sheeting must be overlaid with Type XI sheeting or replaced with new panels utilizing Type XI sheeting prior to elimination of the lighting.

See **FDM 231.2** for sign lighting criteria.

### **230.2.5 Signs on Barriers and Traffic Railings**

For information regarding attachments to bridge traffic railings, concrete median barrier walls, or concrete shoulder barrier walls, refer to **FDM 215.5**.

Utilize [Standard Plans, Index 700-013](#) when attaching the following permanent sign supports to a median traffic railing:

- (1) No U-Turns (R3-4) w/ Official Use Only
- (2) Left Lane Ends (W9-1)
- (3) Lane Ends Merge Right (W9-2)
- (4) Merge Symbol (W4-2)
- (5) Warning, Regulatory, or Advisory Speed signs used as a countermeasure or mitigation for safety conditions
- (6) Shoulder Use Signs

No other permanent signs are to be attached to median traffic railings. [Standard Plans, Index 700-013](#) may be used for temporary or work zone signs when [Standard Plans, Index 102-600](#) cannot accommodate post mounted signs within existing conditions.

### **230.2.6 Signing for Temporary Bridges with Steel Decks**

Place “Slippery When Wet” signs (W8-5) in advance of temporary bridges with steel decks. Refer to [TEM, Section 2.1](#)

### **230.2.7 Object Markers and Delineators**

An object marker is used to mark obstructions within or adjacent to the roadway. The [MUTCD](#) describes four object markers and how they are to be used. A Type 1 (style OM1-3 only) or Type 3 (all styles) object marker is used to mark obstructions within the roadway. A Type 2 (style OM2-2V only) or Type 3 (all styles) object marker is used to mark obstructions adjacent to the roadway. A Type 4 (style OM4-3 only) object marker (end-of-roadway marker) is used to alert users of the end of the road.

A delineator is a guidance device rather than a warning device. The [MUTCD](#) and [Standard Plans, Index 711-003](#) illustrate the use of delineators along the edge of limited access traffic lanes and interchange ramps. A delineator may be a flexible or a non-flexible type. District maintenance offices generally have a preference on which should be specified.

Modification for Non-Conventional Projects:

Delete the last sentence of the above paragraph and see RFP for requirements.

### **230.2.8 Tubular Markers**

Tubular markers are the Department's standard device for the purpose of channelization. The color of tubular markers must be the same color as the pavement marking that they emphasize. They are typically used for channelization at the following locations unless signing (e.g., R4-7 or R4-8) is otherwise required:

- (1) Multilane intersections where additional visibility is required for the marking of an island,
- (2) Marking median openings,
- (3) Nose of traffic separators,
- (4) Where the island is obstructed due to crest vertical curves,
- (5) Intersections where the alignment thru the intersection is not straight,
- (6) Hardened center lines,
- (7) To preclude lane changing where it is not practicable to provide a barrier (e.g. managed lanes, separated bicycle lanes, acceleration lanes), and
- (8) To restrict vehicle movements and control turning speeds.

### **230.2.9 Enhanced Highway Signing Assemblies**

Flashing beacons, highlighted signs, and electronic speed feedback signs may be used to increase the conspicuity of warning and regulatory signs.

For school signing requirements, see **Chapter 15** of the [Speed Zoning for Highways, Roads, and Streets in Florida](#).

Typical applications with these enhancements are shown in [Standard Plans, Index 700-120](#).

### **230.2.10 Internally Illuminated Street Name Signs**

Do not exceed nine feet in width for an internally illuminated street name sign. For span wire systems, the sign is to be mounted to the strain poles. On mast arm supports, the sign may be mounted to the support or to the arm. When mounted to the arm, the distance between the upright and the near side edge of the sign is not to exceed ten feet.

Design the street name sign in accordance with the [TEM, Section 2.2](#). Utilize the following text attributes in order of preference:

- (1) 10-inch upper case with 8-inch lower case, Type EM font
- (2) 10-inch upper case with 8-inch lower case, Type E font
- (3) 8-inch upper case with 6-inch lower case, Type EM font
- (4) 8-inch upper case with 6-inch lower case, Type E font

### 230.2.11 Tourist-Oriented Directional Signs

Tourist-Oriented Directional Signs are guide sign assemblies with individual panels displaying the identity and directional information for a business, service, or activity facilities. These panels are unique in size, content, and have specific criteria for that must comply with [Rule 14-51, Florida Administrative Code](#) and [MUTCD, Chapter 2K](#).

Maximum sign panel dimensions for single and multi-column ground-mounted signs are shown in [Figure 230.2.1](#). Place Tourist-Oriented Directional Signs in accordance with [Standard Plans, Index 700-101](#).

**Figure 230.2.1 Tourist-Oriented Directional Sign Panel Dimensions**

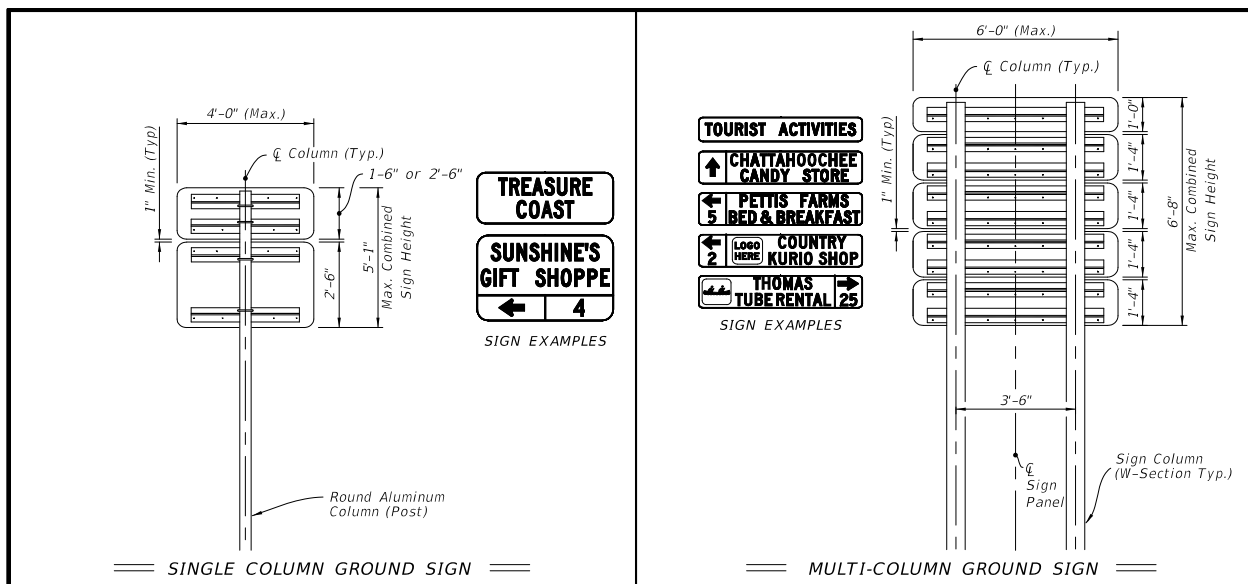

## 230.2.12 Florida National Scenic Trail Signs

Provide signage and pavement markings as shown in **Exhibit 230-b** at all locations where the Florida National Scenic Trail crosses along the SHS.

Use RS-034 signs to guide the public to designated trailhead parking when available and adjacent to the crossing.

## 230.3 Pavement Markings

The **MUTCD** was adopted by the Department as the uniform system of traffic control for use on the streets and highways of the State. This action was in compliance with **Chapter 316.0745** of the **Florida Statutes**. The **MUTCD** is the national standard, and its requirements must be met, as a minimum, on all roads in the State. Where Department manuals indicate criteria which is more stringent than the **MUTCD**, Department criteria is to be followed. See **FDM 220** for signing and pavement marking requirements for at-grade railroad crossings.

### 230.3.1 Selection of Pavement Marking Material

For new pavement markings, use **Table 230.3.1**, as a guide to assist in selecting the appropriate pavement marking material. For any given pavement marking application, the table indicates allowable materials for three different substrates as follows: asphalt pavement (A), concrete pavement (C), and concrete bridge deck (B). The table also indicates when black contrast is required on new pavement surfaces. For existing asphalt surfaces, contact the District Maintenance Engineer to determine if black contrast is required.

Once the pavement marking material is selected from **Table 230.3.1**, verify the project meets the criteria discussed in **FDM 230.3.1.1** through **230.3.1.5**.

For maintaining existing pavement markings, consider the existing pavement condition and coordinate with the District Maintenance Engineer. Possible options for consideration include:

- Refurbishment Thermoplastic
- Hot Spray Thermoplastic
- Durable Paint

Remove existing pavement markings and apply new pavement marking in accordance with **Table 230.3.1**.

**Table 230.3.1 Pavement Marking Material Selection**

Pavement Marking Category	Pavement Marking Application	Color	Material Options						Contrast Required **	
			Hot-Applied Standard Thermoplastic	Hot-Applied High Friction Thermoplastic	Permanent Tape	Preformed Thermoplastic	Two Reactive Components*	Durable Paint		
Solid Lines	Longitudinal Solid Lines	White	A C		C B		A C			
		Yellow	A C		C B		A C			
Skip/ Dotted Lines	Longitudinal Skip Lines (10-30 Skip)	White	A		C B		A		C B **	
		Yellow	A		C B		A			
	Dotted Extension Lines (6-10)	White	A		C B		A		C B **	
		Yellow	A		C B		A			
	Dotted Extension Lines (3-9)	White	A		C B		A		C B **	
		Yellow	A		C B		A			
Dotted Extension Lines (2-4)	White	A			C B	A		C B **		
	Yellow	A			C B	A				
Transverse Markings	Diagonal Cross Hatch	White	A C B			C B				
		Yellow	A C B			C B				
	Chevrons	White	A C B			C B				
	Stop Lines		A			C B			C B **	
	Yield Lines (Sharktooth)		A			C B			C B **	
	Special Emphasis Crosswalk Longitudinal Bars- 24"			A			A C B			
	Standard and Special Emphasis Crosswalk Transverse Lines-12"		A				C B			
Railroad Dynamic Envelope						A C B			C B **	
Messages and Symbols	Text Messages		White	A			A C B			C B **
	Lane Use Arrows	A				A C B			C B **	
	Ramp Exit Numbers					A C B			C B **	
	Bicycle Markings (Symbols, Messages)					A C B			C B **	
	Shared Use Path Markings (Symbols, Messages)					A C B			C B **	
	Wrong Way Arrows	A					A C B			C B **
	Route Shields	Multi-color				A C B			C B **	
Curb Delineation	Island Nose	Yellow						A C B		
Legend:	A = Asphalt Pavement    C = Concrete Pavement    B = Concrete Bridge Deck									
* Two Reactive Components requires approval by District Maintenance Engineer and District Construction Engineer ** For existing asphalt surfaces, contact the District Maintenance Engineer to determine if contrast is required.										



### 230.3.1.1 Longitudinal Solid Lines

The following applies to Longitudinal Solid Line material selection:

- For asphalt surfaces:
  - Hot-Applied Standard Thermoplastic is the default material for this application.
  - Two Reactive Components may be used at the discretion of the District Maintenance Engineer.
- For concrete surfaces:
  - Hot-Applied Standard Thermoplastic is the default material for this application.
  - Consider the use of Permanent Tape where equipment mobilization for Hot Applied Thermoplastic is not feasible.
  - Two Reactive Components may be used at the discretion of the District Maintenance Engineer.
  - Use contrast consistent with [Standard Plans Index 711-001](#) for solid white lane lines. Do not use contrast on solid edge lines.
- For Concrete Bridge Deck Surfaces:
  - Use Permanent Tape.
  - Use contrast consistent with [Standard Plans Index 711-001](#) for solid white lane lines. Do not use contrast on solid edge lines.

### 230.3.1.2 Skip/Dotted Lines

The following applies to Longitudinal Skip Line (10-30), Dotted Extension Line (6-10), and Dotted Extension Line (3-9) material selection:

- For Asphalt Surfaces:
  - Hot-Applied Standard Thermoplastic is the default material for this application.
  - Two Reactive Components may be used at the discretion of the District Maintenance Engineer.

- For Concrete and Concrete Bridge Deck Surfaces:
  - Use Permanent Tape

The following applies to Dotted Extension Line (2-4) material selection:

- For Asphalt Surfaces:
  - Hot-Applied Standard Thermoplastic is the default material for this application.
  - Two Reactive Components may be used at the discretion of the District Maintenance Engineer.
- For Concrete and Concrete Bridge Deck Surfaces:
  - Use Preformed Thermoplastic.

Use contrast consistent with [Standard Plans Index 711-001](#) for all skip/dotted lines requiring contrast.

### **230.3.1.3 Transverse Markings**

The following applies to Diagonal Cross Hatch and Chevron material selection:

- For Asphalt surfaces:
  - Use Hot-Applied Standard Thermoplastic.
- For Concrete and Concrete Bridge Deck Surfaces:
  - Hot-Applied Standard Thermoplastic is the default material for this application.
  - Consider the use of Preformed Thermoplastic where quantities are small and equipment mobilization for Hot Applied Standard Thermoplastic is not feasible.

The following applies to Stop Line, Yield Line, and 12-inch Transverse Line at standard and special emphasis crosswalks material selection:

- For Asphalt Surfaces:
  - Use Hot-Applied Standard Thermoplastic.
- For Concrete and Concrete Bridge Deck Surfaces:
  - Use Preformed Thermoplastic.

The following applies to 24-inch Longitudinal Bars at special emphasis crosswalks material selection:

- For Asphalt Surfaces
  - Preformed Thermoplastic is the default material for this application.
  - Hot applied High Friction Thermoplastic is a contractor's option to Preformed Thermoplastic and should not be called out in the plans.
- For Concrete and Concrete Bridge Deck Surfaces:
  - Use Preformed Thermoplastic.

The following applies to Railroad Dynamic Envelope Material selection:

- For Asphalt, Concrete, and Concrete Bridge Deck Surfaces:
  - Use Preformed Thermoplastic.

Provide the following where contrast is required for transverse markings and include details in the plans:

- Special Emphasis Crosswalk 24-inch Longitudinal Bars: Provide 4-inch-wide black contrast border on both sides of longitudinal bars.
- Yield Lines (Sharktooth): Provide black contrast block with a minimum of 1.5 inches from the yield line perimeter to the edges of the block.
- Stop Lines: Provide 4-inch-wide black contrast border on both sides of stop line.
- Railroad Dynamic Envelope: Provide 4-inch-wide black contrast border on both sides of each 12-inch-wide line.

#### **230.3.1.4 Messages and Symbols**

The following applies to Text Message, Lane Use Arrow, and Wrong Way Arrow material selection:

- For Asphalt Surfaces
  - Hot-Applied Standard Thermoplastic is the default material for this application.
  - Consider the use of Preformed Thermoplastic where quantities are small and equipment mobilization for Hot Applied Standard Thermoplastic is not feasible.

- For Concrete and Concrete Bridge Deck Surfaces:
  - Use Preformed Thermoplastic.
- For Ramp Exit Numbers, Bicycle Markings, Shared Use Path Markings, and Route shields use Preformed Thermoplastic for asphalt, concrete, and bridge deck surface.
- Provide the following for message and symbol markings requiring contrast and include details in the plans:
  - Lane Use Arrows, Wrong Way Arrows, Messages, and Symbols with design speed 45 MPH and less – Provide 1.5-inch minimum black contrast border adjacent to the perimeter of the pavement marking.
  - Lane Use Arrows, Wrong Way Arrows, Messages, and Symbols with design speed greater than 45 MPH – Provide black contrast block with a minimum of 1.5 inches from the pavement marking perimeter to the edges of the block.
  - Intricate Symbols - For intricate symbols such as the Helmeted Bicyclist Symbol, use black contrast block for all design speeds.

### **230.3.1.5 Curb Delineation**

Use Durable Paint for curb delineation at island noses.

## **230.3.2 Pavement Marking Maintenance**

Two standard methods to extend the life of existing pavement markings are the application of Refurbishment Thermoplastic and Hot Spray Thermoplastic. These applications are often used when existing pavement markings no longer meet specification requirements, and the anticipated service life of the pavement is approximately 3 years or greater. Refurbishment Thermoplastic and Hot Spray Thermoplastic are discussed in the following sub-sections.

Use of Durable Paint is an option for asphalt pavement where the longer service life of Refurbishment Thermoplastic is not required. Durable Paint should not be used in areas opened to traffic due to the prolonged cure time of approximately 20 minutes. Prior to use, contact the District Maintenance Engineer to determine if use of Durable Paint is recommended.

### **230.3.2.1 Refurbishment Thermoplastic**

Refurbishment Thermoplastic is the placement of new hot-applied thermoplastic material on top of existing pavement markings at a minimum thickness of 0.06 inches (60 mils). On concrete riding surfaces (i.e., concrete pavement and bridge deck surfaces) with existing Permanent Tape pavement markings, remove and replace in accordance with **Table 230.3.1**.

Consider the following when contemplating the use of refurbishment markings:

- Remaining service life of the pavement
- Thickness and conditions of existing markings
- Traffic volumes
- Cost of markings
- Other special requirements such as contrast needs or ground-in rumble strip installation

Coordinate with the District Maintenance Engineer to determine if Refurbishment Thermoplastic is appropriate. If Refurbishment Thermoplastic cannot be applied without exceeding the maximum thickness of 0.150 inches (150 mils), use Hot Spray Thermoplastic, or remove the existing markings before placing Hot-Applied Standard Thermoplastic markings. When contemplating use of Refurbishment Thermoplastic, consider an anticipated service life of 2-4 years. Refer to [Standard Specification 711](#) for additional information on Standard and Refurbishment Thermoplastic.

### **230.3.2.2 Hot Spray Thermoplastic**

Hot Spray Thermoplastic is the application of a minimum 0.04-inch (40 mil) application of Hot Spray Thermoplastic material on existing longitudinal pavement markings.

Use of Hot Spray Thermoplastic may be conducive in the following circumstances:

- Existing audible or vibratory pavement markings need to have retroreflectivity restored.
- Resurfacing is scheduled within 2-4 years
- Refurbishment Thermoplastic would result in excessive pavement marking thickness and the removal and replacement with Standard Thermoplastic is cost prohibitive.

- Condition of the existing pavement has deteriorated such that removal and replacement is not an option as it would cause greater damage to the existing pavement.

### **230.3.3 No-Passing Zones**

Follow the procedures contained in the [MUTS](#) for determining the limits of no-passing zones.

Limits of pavement markings for no-passing zones will be established by one of the following methods:

- (1) On projects where existing roadway conditions (vertical and horizontal alignments) are to remain unaltered by construction, the no-passing zones study will be accomplished as part of the design phase. The limits of the no-passing zones will be shown on the plans.
- (2) On projects with new or altered vertical and horizontal alignments, limits for no-passing zones will be established during construction. The required traffic study and field determination of limits will be performed by the designer during post design. Sufficient time must be included to accomplish the required field operations without delaying or interfering with the construction process.

For 2-Lane, 2-way roadways, a no-passing zone study should be conducted if any of the following conditions apply subsequent to the last roadway resurfacing project:

- (1) Newly constructed intersections
- (2) Multiple new residential or commercial driveway connections
- (3) New sight distance obstructions due to vegetation, tree growth or buildings
- (4) History of wrong way/head-on crashes or observations/complaints of near misses

### **230.3.4 Work Zone Pavement Markings**

Use Standard Paint for work zone markings on asphalt and concrete pavement. The performance of Standard Paint has been evaluated by the Department for a period of 6 months.

Consider using Durable Paint or Refurbishment Thermoplastic when a work zone phase is expected to last for more than a year under heavy traffic volumes. The performance of Durable Paint has been evaluated by the Department for a period of 18 months.

Use Removable Tape for transitions on the final structural course or dense-graded friction course. Removable Tape may be used for other markings to avoid the removal of paint and scaring of final surface. Do not use Removable Tape for application durations of more than 6 months. Do not use Removable Tape on open-graded friction course.

Use contrast consistent with [Standard Plans Index 711-001](#) for solid white lane lines. Do not use contrast on solid edge lines.

### **230.3.5 Raised Pavement Markers (RPMs)**

Retroreflective RPMs, Class B, are the standard type of RPM.

Internally illuminated RPMs are similar to retroreflective RPMs but are internally illuminated with LEDs. Internally illuminated RPMs may be used in lieu of retroreflective RPMs to enhance delineation and driver awareness as a mitigation strategy for substandard conditions as defined in the [TEM, Section 4.6](#).

Place all RPMs in accordance with the [Standard Plans, Index 706-001](#) and the [MUTCD](#).

## **230.4 Wrong-Way Signs and Pavement Markings**

Deploy the enhanced signing and pavement markings in this section to improve positive guidance, to minimize driver confusion, and to reduce wrong-way movements. The height of WRONG WAY (R5-1a) signs must be in accordance with [Standard Plans, Index 700-101](#). Include red retroreflective strips on DO NOT ENTER (R5-1) and static WRONG WAY (R5-1a) sign columns in accordance with the [MUTCD 2A.21](#). Include white retroreflective strips on ONE WAY (R6-1) sign columns in [Exhibits 230-5, 230-6, and 230-7](#) in accordance with the [MUTCD 2A.21](#). These wrong-way prohibitive signs and pavement markings are used to enhance driver awareness. They are in addition to other required signs and pavement markings that are not shown in exhibits.

### **230.4.1 Exit Ramp Intersections**

The standard for signing and pavement marking and advanced countermeasure installation at exit ramp intersections are illustrated in [Exhibits 230-1a](#) and [230-1b](#). The description of the layouts are as follows:

- (1) Include MUTCD “optional” signs; second DO NOT ENTER (R5-1), second WRONG WAY (R5-1a), and ONE WAY (R6-1) signs.

- (2) Include NO RIGHT TURN (R3-1) and COMBINATION U-TURN & LEFT TURN PROHIBITION (R3-18) signs.
- (3) Use 42 inches by 30 inches WRONG WAY (R5-1a) signs.
- (4) Modify distances between signs and detectors as appropriate for multi-lane ramps.
- (5) Include yellow 2'-4' dotted guideline striping on left edge line and white dotted guideline striping on right edge or lane line for left turns between ramps entrances/exits and cross-streets.
- (6) Include retroreflective yellow paint on ramp median nose where applicable. Include RPMs on ramp median nose in accordance with [Standard Plans, Index 706-001](#).
- (7) Include a straight arrow and route interstate shield pavement marking in left-turn lanes extending from the far-side ramp intersection through the near-side ramp intersection to prevent premature left turns. Refer to [TEM, Section 4.2.4](#) "Route Shields for Wrong-Way Treatment" for additional information.
- (8) Include a straight arrow and ONLY pavement message in outside lane approaching the ramp exit.
- (9) Coordinate with the District Traffic Operations Engineer (DTOE) to determine if a wrong-way vehicle detection system and a pair Light-emitting Diode (LED) Highlighted WRONG WAY (R5-1a) signs are required. If the DTOE determines they are required, install as illustrated in [Exhibits 230-1a and 230-1b](#). The Highlighted Sign assembly may be solar powered or AC powered. If powered by AC, provide a power service assembly, conduits, and power conductors from the Highlighted Sign to the local cabinet. The Highlighted Sign must be integrated back to the District's Traffic Management Center (TMC). Connectivity between the Highlighted Sign and the TMC may be provided by either fiber optic or wireless communications. If fiber optic communications are used, include the fiber optic cable, conduit, and transmission equipment. If wireless communications are used, include the antenna and communication devices.

Modification for Non-Conventional Projects:

Delete item (9) above and see the RFP.

## 230.4.2 Diverging Diamond Intersections

Signing of Diverging Diamond Intersections is an evolving practice and not explicitly addressed in the MUTCD, however typical signing and pavement markings at diverging



diamond crossovers and exit ramp intersections are illustrated in **Exhibit 230-2** and described as follows:

- (1) Include DO NOT ENTER (R5-1), WRONG WAY (R5-1a), and ONE WAY (R6-1) signs.
- (2) Include NO RIGHT TURN (R3-1), NO LEFT TURN (R3-2), and COMBINATION U-TURN & LEFT TURN PROHIBITION (R3-18) signs.
- (3) Include KEEP RIGHT (R4-7), KEEP LEFT (R4-8), and OBJECT MARKER (OM3) signs.
- (4) Use 42 inches by 30 inches WRONG WAY (R5-1a) signs.
- (5) Include white 2'-4' dotted guideline striping for through movements at the crossover location turns as well as at ramp entrances/exits.
- (6) Include retroreflective yellow paint on crossover and ramp median nose where applicable. Include RPMs on ramp median nose in accordance with [Standard Plans, Index 706-001](#).
- (7) Include a straight arrow pavement marking in all through lanes for the crossover maneuver in both directions on the downstream side of the crossover intersections.
- (8) Include Wrong-Way Arrow pavement markings in all through lanes for the crossover maneuver in both directions on the upstream side of crossover intersections.
- (9) Include route interstate shield pavement marking in the left turn lane(s) prior to and after the crossover intersection. Refer to TEM, Section 4.2.4 "Route Shields for Wrong-Way Treatment" for additional information.
- (10) Include a left turn arrow and ONLY pavement message in exclusive left turn lanes approaching ramp entrances.

See **FDM D217** for more information on Diverging Diamond Interchanges.

### 230.4.3 Divided Arterials and Collectors

Provide Wrong-Way Arrow pavement markings at unsignalized intersections with median widths of 20 feet or greater.

Provide DO NOT ENTER (R5-1) signs and WRONG WAY (R5-1a) signs at unsignalized intersections with median nose widths of 30 feet or greater. Orient each sign face at 45 degrees toward the connection it is intended to regulate. For median nose widths less than 30 feet, the median DO NOT ENTER (R5-1) and WRONG WAY (R5-1a) signs are optional. Place each sign as close to the wrong-way roadway as possible while meeting the placement criteria of [Standard Plans, Index 700-101](#).

See **Exhibits 230-3** and **230-4** for recommended configurations of Wrong-Way Arrow pavement markings, DO NOT ENTER (R5-1) signs, and WRONG WAY (R5-1a) signs.

*Commentary: For median nose widths less than 30 feet, median DO NOT ENTER (R5-1) and WRONG WAY (R5-1a) signs should only be considered in high-risk locations (as described below). If placed in these narrower medians, ensure details in the plans clearly specify 45-degree rotation of each sign toward the wrong way movements to reduce visibility to those making proper turning movements.*

At intersections with positive offset left-turns, use DO NOT ENTER (R5-1) signs with dimensions of 48 inches by 48 inches. See **FDM 212.14.4** for further information on offset left turn lanes.

For Context Classifications C1, C2, C3C, and C4 place Wrong-Way Arrow pavement markings in all lanes prior to unsignalized, stop-controlled connection (i.e., side streets, commercial driveways, or driveways). Space Wrong-Way Arrow pavement markings no closer than 300 feet. For all other Context Classifications, consider placing Wrong-Way Arrow pavement markings as described above where high-risk locations are present.

Coordinate with the District Traffic Operations Engineer (DTOE) to evaluate high-risk locations using factors such as land-use, presence of lighting, history of impaired driving, crash history, and an over-represented population of licensed drivers 25 or younger and 65 or older. Determination of high-risk locations is at the discretion of the DTOE.

At intermediate ends of medians, consider the use of KEEP RIGHT (R4-7) sign for median nose widths less than 30 feet.

#### **230.4.4 One-Way Pairs and Divided Arterials/Collectors with One-Way Egress**

One-Way Egress is a condition where a two-way or one-way side street, commercial driveway, or driveway connects to a one-way arterial/collector or divided arterial/collector without a median opening.

See **Exhibit 230-5** for recommended configurations.

Place a ONE WAY (R6-1) sign at signalized and unsignalized, stop-controlled connection (i.e., side streets, commercial driveways, or driveways) with one-way egress. ONE WAY (R6-1) sign shall be placed on far side median or shoulder depending on facility type.

At driveways controlled by a non-signalized traffic control device with one-way egress, place a RIGHT TURN ARROW (FTP-55R-06) sign or a LEFT TURN ARROW (FTP-55L-06) sign below the STOP (R1-1) sign. Verify this sign has not already been installed by District driveway permit. At side street connections, place a Mandatory Lane Control (R3-5) sign below the STOP (R1-1) sign.

For Context Classifications C1, C2, C3C, and C4 place Wrong-Way Arrow pavement markings in all lanes prior to signalized and unsignalized, stop-controlled connection (i.e., side streets, commercial driveways, or driveways) with one-way egress. Space Wrong-Way Arrow pavement markings no closer than 300 feet. For all other Context Classifications, consider placing Wrong-Way Arrow pavement markings as described above where high-risk locations are present. Coordinate with the District Traffic Operations Engineer (DTOE) to evaluate high-risk locations using factors such as land-use, presence of lighting, history of impaired driving, crash history, and an over-represented population of licensed drivers 65 and older. Determination of high-risk locations is at the discretion of the DTOE.

#### **230.4.5 Undivided One-Way Streets**

For two-way street approaches, place the following signs and pavement markings as illustrated in **Exhibit 230-6**:

- (1) Place the corresponding turn prohibition (R3 Series) symbolic sign on the right-hand side of the approach street.
- (2) Place DO NOT ENTER (R5-1) signs on both sides of the one-way street.

- (3) Place Wrong-Way Arrow pavement markings in all lanes upstream of side street.
- (4) Add turn and through lane-use arrow on approaches to the one-way street.
- (5) For one-way approaches, place the following signs and pavement markings as illustrated in **Exhibit 230-7**:
- (6) Place the corresponding turn prohibition (R3 Series) symbolic sign. Where overhead structures exist, consider placement of a secondary turn prohibition sign over the lane or closest to the direction it is prohibiting.
- (7) Place DO NOT ENTER (R5-1) signs on both sides of the one-way street.
- (8) Place Wrong-Way Arrow pavement markings in all lanes prior to the side street.

#### **230.4.6 Two-Way Signalized Intersections**



Provide the following signing and pavement markings as illustrated in **Exhibit 230-8** for intersections serving two-way traffic where the distance from the side street stop bar to the arterial receiving lane meets or exceeds 60 ft:

- (1) Place yellow 2'-4' dotted guide center line for left turn movement onto a two-way state route.
- (2) Where design or conditions deem it appropriate to provide enhanced positive guidance for the driver, include yellow 2'-4' dotted guide center line for left turn movement off the state route.
- (3) For multiple left turn lanes, place white 2'-4' dotted guideline for right edge or lane line. For single left turn lane, white 2'-4' dotted guideline may be provided on right edge line.

If a two-way street crosses a one-way street at a signalized intersection, the criteria of **FDM 230.4.5** applies.

# STANDARD SIGNING AND PAVEMENT MARKING AT EXIT RAMP INTERSECTIONS

## LEGEND

-  Wrong-Way Arrows
-  Wireless Antenna
-  Lane Assignment Arrows

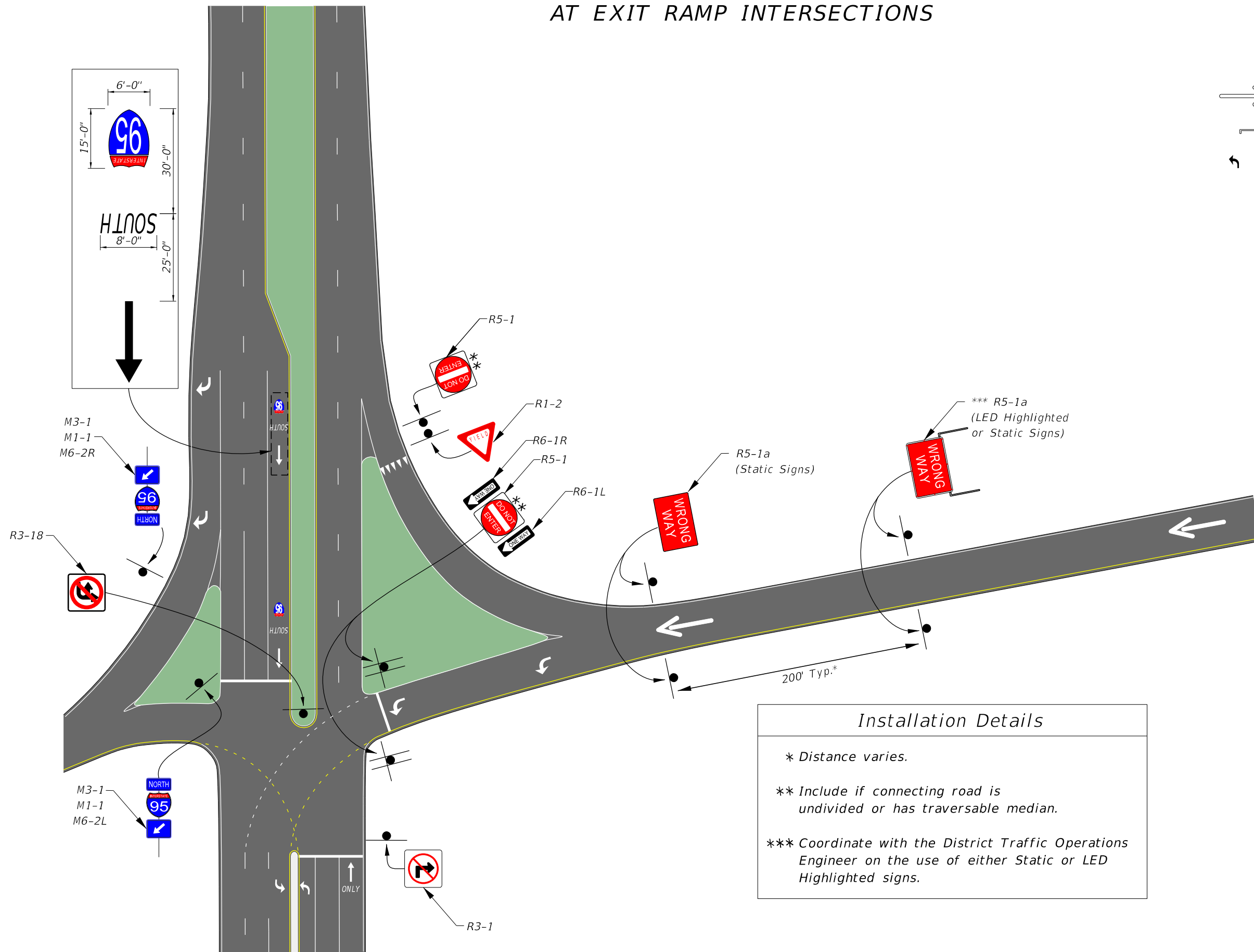

*Installation Details*

- \* Distance varies.
- \*\* Include if connecting road is undivided or has traversable median.
- \*\*\* Coordinate with the District Traffic Operations Engineer on the use of either Static or LED Highlighted signs.

NOT TO SCALE

EXHIBIT 230-1a  
01/01/2023

# TYPICAL LAYOUT FOR PARTIAL CLOVERLEAF/TRUMPET EXIT RAMP INTERSECTION

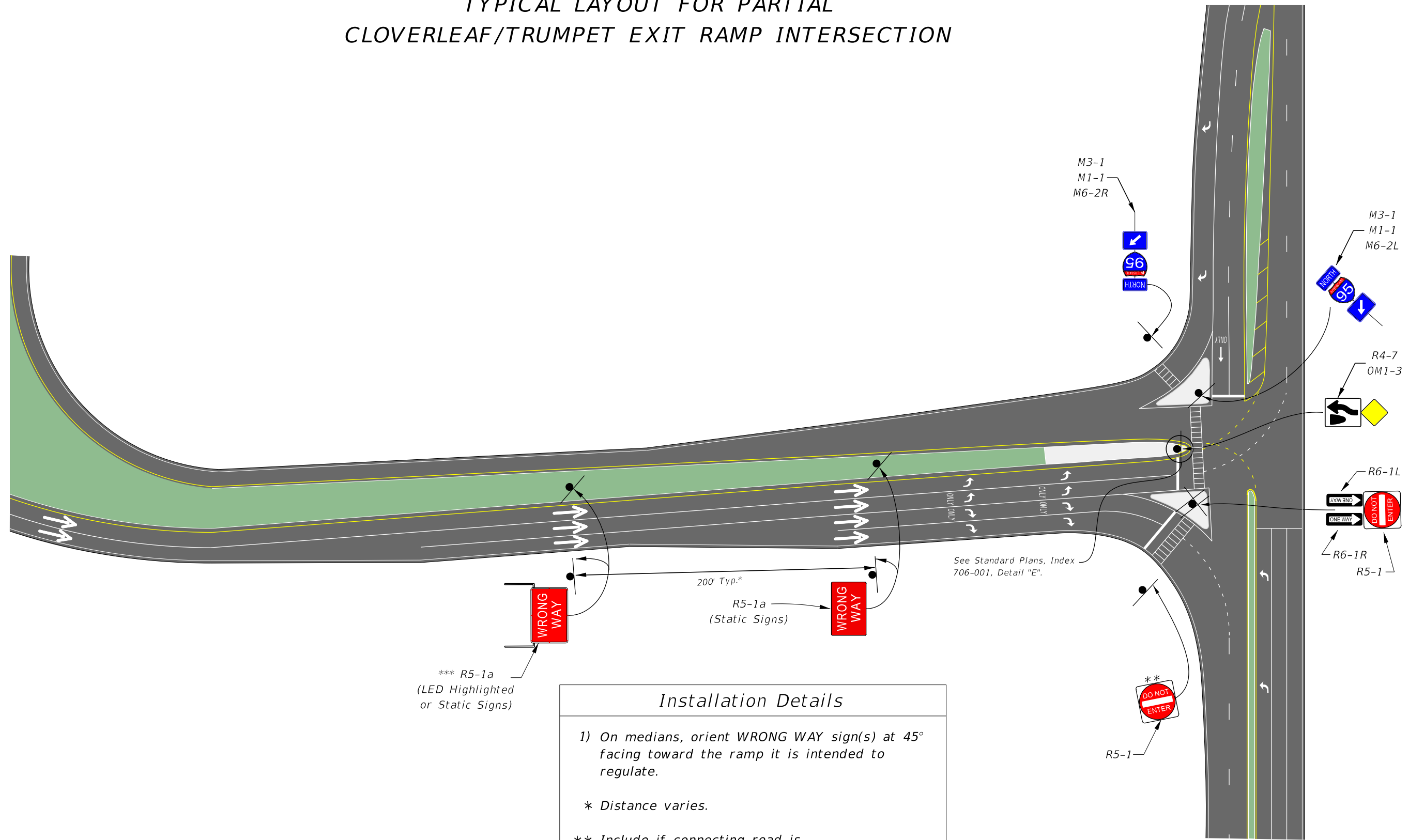

**Installation Details**

1) On medians, orient **WRONG WAY** sign(s) at 45° facing toward the ramp it is intended to regulate.

\* Distance varies.

\*\* Include if connecting road is undivided or has traversable median.

\*\*\* Coordinate with the District Traffic Operations Engineer on the use of either Static or LED Highlighted signs.

- LEGEND**
- Wrong-Way Arrows
  - Wireless Antenna
  - Lane Assignment Arrows

NOT TO SCALE

EXHIBIT 230-1b  
01/01/2023

# DIVERGING DIAMOND INTERSECTIONS

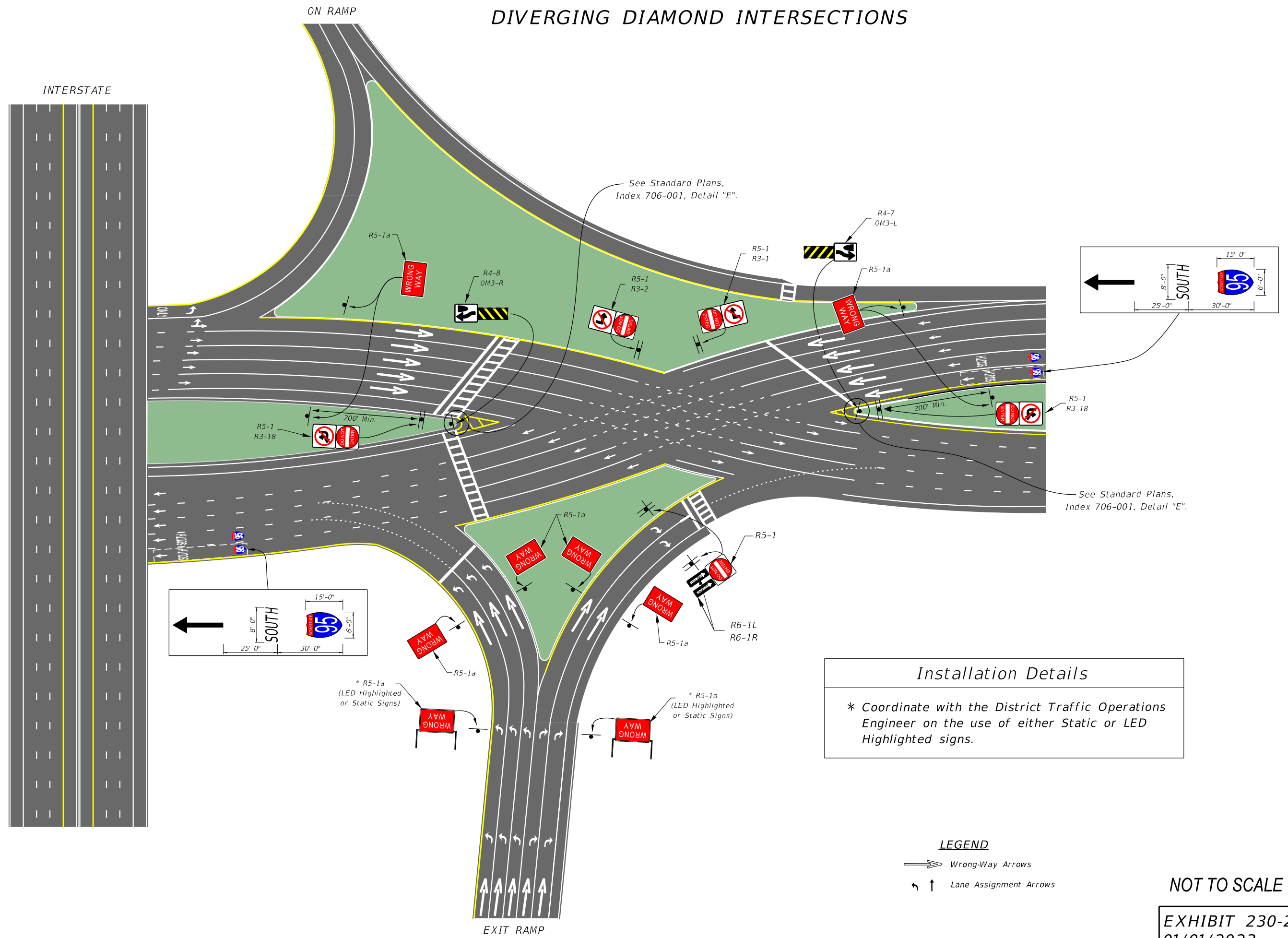

**Installation Details**

\* Coordinate with the District Traffic Operations Engineer on the use of either Static or LED Highlighted signs.

**LEGEND**

→ Wrong-Way Arrows

↖ ↑ Lane Assignment Arrows

NOT TO SCALE

EXHIBIT 230-2  
01/01/2023

# WRONG-WAY SIGNING AND PAVEMENT MARKING AT 4-LEG UNSIGNALIZED INTERSECTIONS ALONG DIVIDED ARTERIALS/COLLECTORS

## Installation Details

\* If median nose width is <30 ft, these R5-1 and R5-1a signs are optional. See FDM 230.4.3

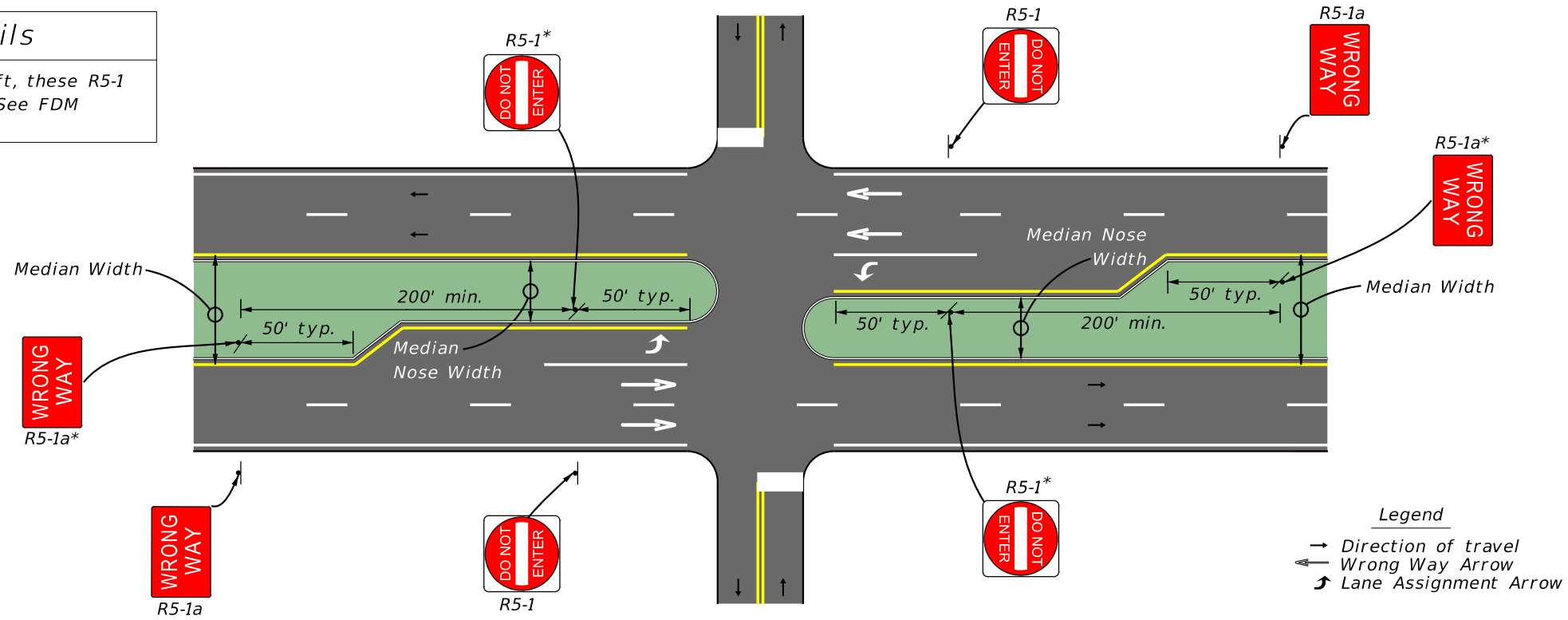

NOT TO SCALE

EXHIBIT 230-3  
10/2022

# WRONG-WAY SIGNING AND PAVEMENT MARKING AT 3-LEG UNSIGNALIZED INTERSECTIONS ALONG DIVIDED ARTERIALS/COLLECTORS

## Installation Details

(1) Median Nose Width is equal to Median Width when auxiliary lanes are not present.

\* If median nose width is <30 ft, these R5-1 and R5-1a signs are optional. See FDM 230.4.3.

\*\* Wrong Way Arrows optional when Downstream One-Way Egress is present. See Exhibit 230-5 for signing at these One-Way Egress locations.

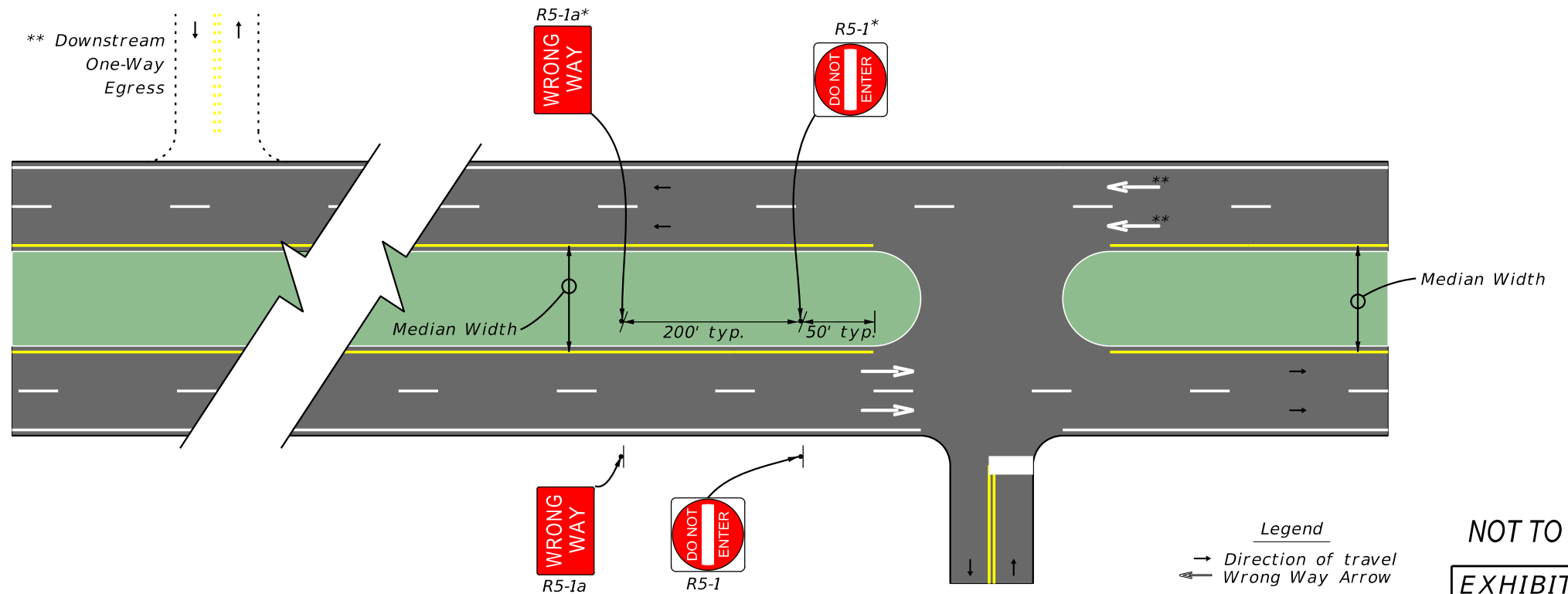

NOT TO SCALE

EXHIBIT 230-4  
10/2022



# ONE-WAY PAIRS AND DIVIDED ARTERIALS/COLLECTORS WITH UNSIGNALIZED ONE-WAY EGRESS

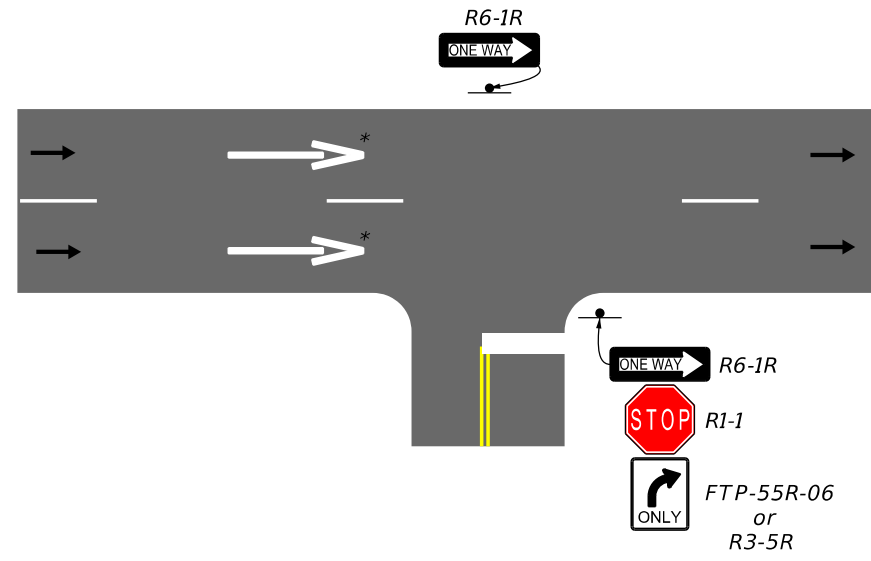

- Installation Details*
- 1) R6-1 shall be placed on far side median or shoulder depending on facility type.
  - 2) RIGHT TURN ARROW (FTP-55R-06) or LEFT TURN ARROW (FTP-55L-06) typically added by district driveway permit.
  - 3) Mandatory Movement Lane Control (R3-5) sign must be added to side street.
- \* See FDM 230.4.4 for how often to place Wrong-Way arrows based on context classification.

Legend  
 → Direction of travel  
 ← Wrong Way Arrow

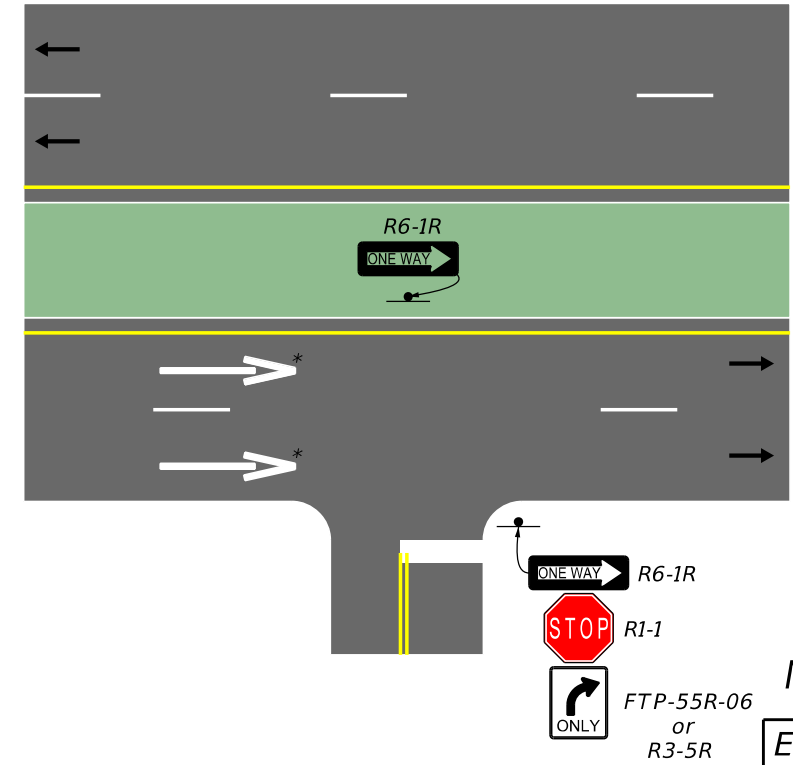

NOT TO SCALE  
 EXHIBIT 230-5  
 10/2022

## TYPICAL TWO-WAY APPROACH TO UNDIVIDED SIGNALIZED AND UNSIGNALIZED ONE-WAY STREET

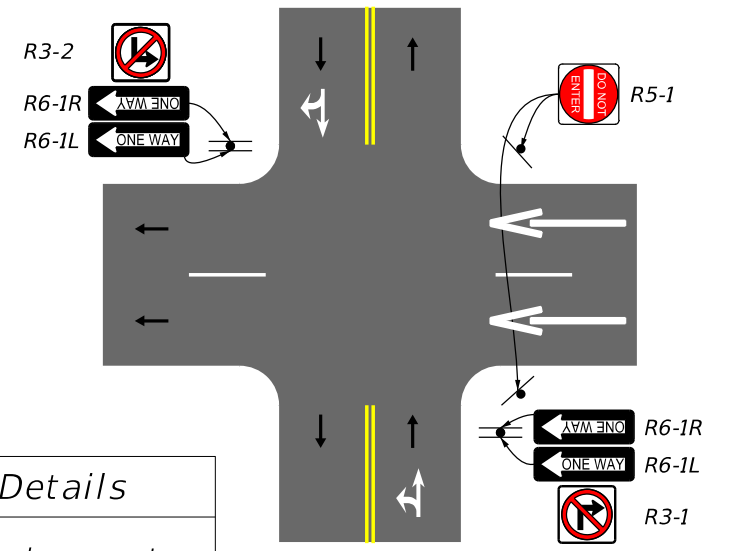

- Installation Details*
- 1) Wrong-Way signing and pavement markings for signalized and stop control.
  - 2) Place Wrong-Way arrows four feet upstream of stop bar, if present.

Legend  
 → Direction of travel  
 ← Wrong Way Arrow  
 ↗ Lane Assignment Arrow

NOT TO SCALE  
 EXHIBIT 230-6  
 10/2022

## TYPICAL ONE-WAY APPROACH TO UNDIVIDED SIGNALIZED AND UNSIGNALIZED ONE-WAY STREET

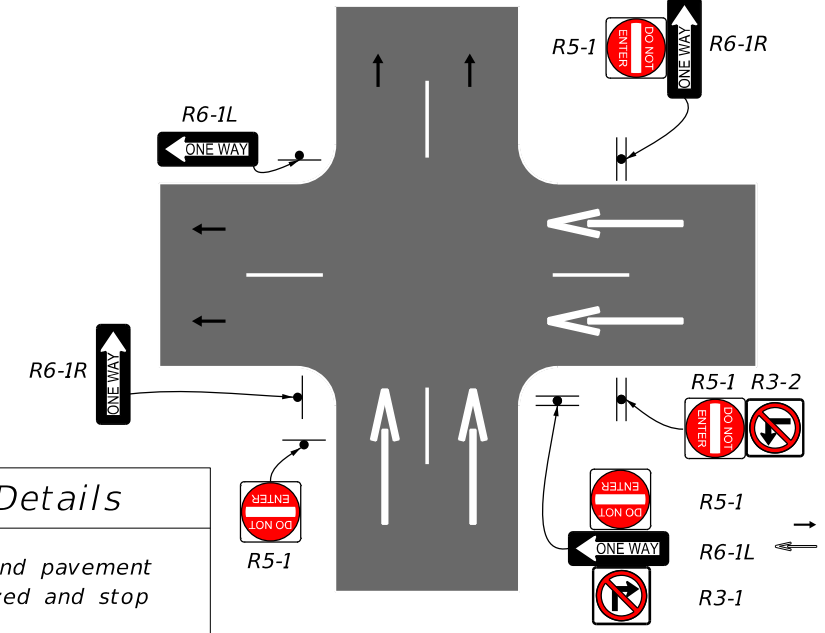

- Installation Details*
- 1) Wrong-Way signing and pavement markings for signalized and stop control.
  - 2) Place Wrong-Way arrows four feet upstream of stop bar, if present.

Legend  
 → Direction of travel  
 ← Wrong Way Arrow

NOT TO SCALE  
 EXHIBIT 230-7  
 10/2022

# TYPICAL DOTTED LINE MARKINGS TO EXTEND CENTER LINE AND LANE LINE MARKINGS INTO SIGNALIZED INTERSECTION

## Installation Details

- 1) Center line extensions in the intersection shall be dotted guide yellow lines.
- 2)  $d \geq 60$  ft. The distance of the left turn from the side street stop bar to the arterial receiving lane meets or exceeds 60 ft. See FDM 230.4.6.

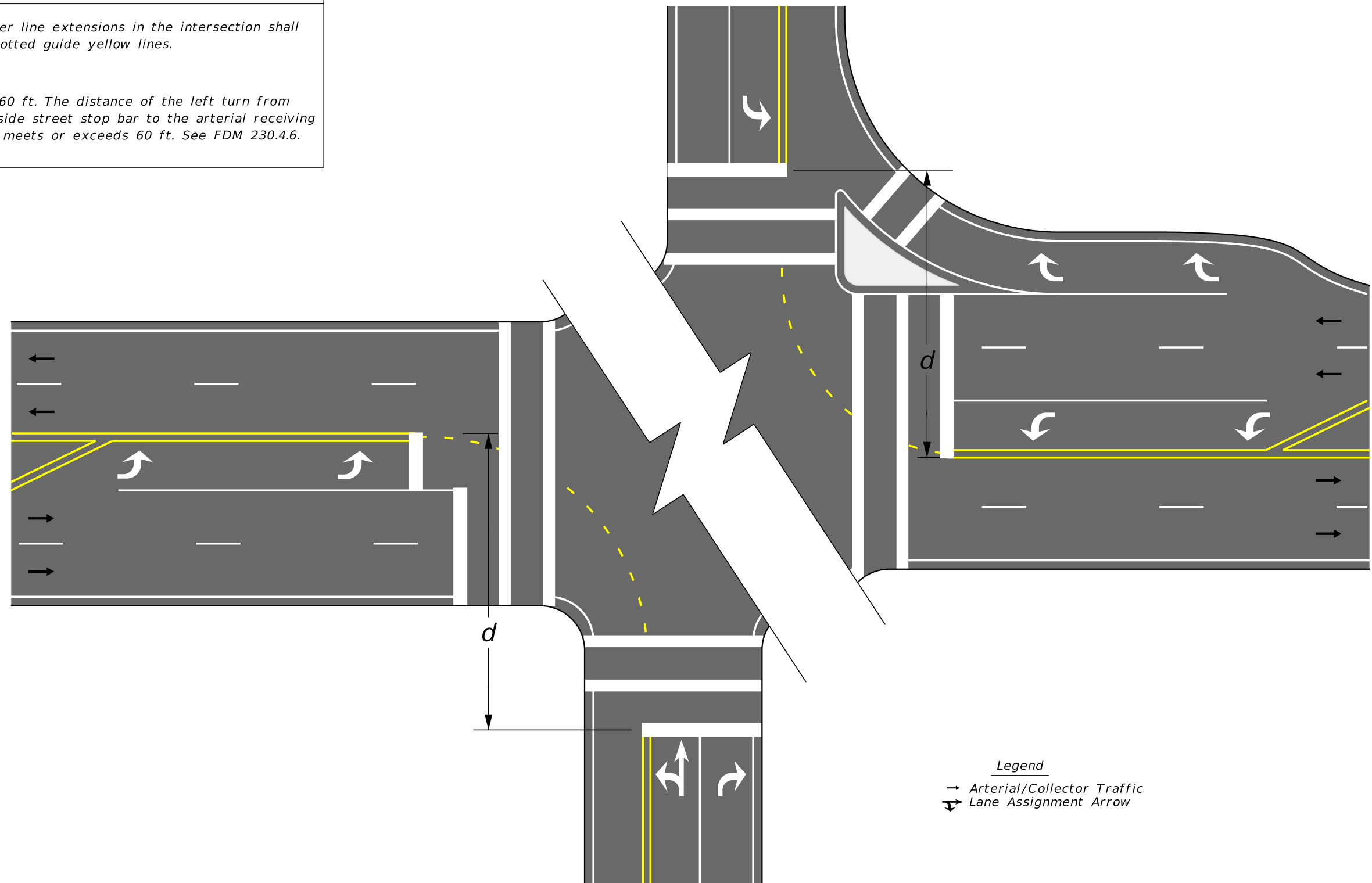

Legend  
→ Arterial/Collector Traffic  
↪ Lane Assignment Arrow

NOT TO SCALE

EXHIBIT 230-8  
06/01/2021

## **230.5      Signing and Pavement Marking Coordination**

Coordination with other offices and agencies is a very important aspect of signing and pavement marking design. The offices discussed in this section are those that are typically involved in developing signing and marking plans; however, there may be other offices or agencies involved.

The District Utilities Engineer provides the coordination between the designer and the various utilities. The Utilities Section may assist in identifying or verifying conflicts with overhead and underground utilities. The District Utilities Engineer should be contacted as early in the design phase as possible.

The Structures EOR provides the design of the sign structure and foundation for overhead cantilever and overhead truss sign assemblies. The Structures EOR should be contacted early in the design phase to allow adequate time for coordination with the Geotechnical Engineer in obtaining the necessary soils information.

Contact the State Outdoor Advertising and Logo Manager on any project affecting business logo structures. Refer to **FDM 110.5.5** for requirements and additional information.

## **230.6      Typical Signing and Pavement Marking Configurations**

The following sub-sections describe standard signing and pavement marking applications for midblock crosswalks, Florida scenic trails, median openings along divided arterials/collectors, roadway transitions, stop controlled intersections along divided arterials/collectors, and residential and minor street terminations.

### **230.6.1 Midblock Crosswalks**

Typical signing and pavement markings for stop controlled and signal controlled midblock crosswalks are illustrated in **Exhibit 230-9** and described as follows:

- (1) Include PEDESTRIAN TRAFFIC (W11-2), DIAGONAL ARROW (W16-7p), AHEAD (W16-9p), and STOP HERE FOR PEDESTRIANS (R1-5p) signs
- (2) Include 24" white stop line placed 40 feet plus or minus 10 feet in advance of the marked crosswalk.
- (3) Include 6" solid white lane lines 100 feet in length upstream of each approach and terminating at the stop line.
- (4) Include special emphasis crosswalk markings consistent with [Standard Plans](#), **Index 711-001**.

### **230.6.2 Florida Scenic Trails**

Typical signing and pavement markings for Florida Scenic Trails are illustrated in **Exhibit 230-10** and described as follows:

- (1) Include FLORIDA NATIONAL SCENIC TRAIL 1000 FEET, PEDESTRIAN CROSSING (W11-2), DIAGONAL ARROW (W16-7p), and AHEAD (W16-9p) signs.
- (2) Include FLORIDA NATIONAL SCENIC TRAIL, TRAIL MARKER, and HIKING TRAIL (RS-068) signs.
- (3) Include special emphasis crosswalk markings consistent with [Standard Plans](#), **Index 711-001**.

### **230.6.3 4-Leg Stop Controlled Intersections Along Divided Arterials/Collectors**

Typical signing and pavement markings for stop controlled median openings along divided highways are illustrated in **Exhibit 230-11** and described as follows:

- (1) Include DIVIDED HIGHWAY CROSSING (R6-3), STOP (R1-1), and ONE WAY (R6-1) signs.
- (2) Include YIELD (R1-2) and ONE WAY (R6-1) signs in the median when the median nose width is 30 feet or greater.

- (3) Divided highway signs (R6-3) may be on the same structure with the STOP and ONE WAY signs or on a separate structure.
- (4) See the [MUTCD](#) and [Standard Plans, Index 711-001](#) for additional pavement marking details.
- (5) See **FDM 230.4** for Wrong-Way signs and pavement markings.

### **230.6.4 3-Leg Stop Controlled Intersections Along Divided Arterials/Collectors**

Typical signing and pavement markings for 3-leg stop controlled intersections along divided arterials/collectors are illustrated in **Exhibit 230-12** and described as follows:

- (1) Include DIVIDED HIGHWAY CROSSING (R6-3a), STOP (R1-1), and ONE WAY (R6-1) signs.
- (2) Include YIELD (R1-2) and ONE WAY (R6-1) signs in the median when the median nose width is 30 feet or greater.
- (3) Include OBJECT MARKER (OM1-3) as shown and in accordance with **Specification 705** and [Standard Plans, Index 700-010](#).
- (4) See the [MUTCD](#) and [Standard Plans, Index 711-001](#) for additional pavement marking details.
- (5) Provide sheeting on signs and object markers in accordance with **Specification 993**.
- (6) See **FDM 230.4** for Wrong-Way signs and pavement markings.

### **230.6.5 Residential and Minor Street Terminations**

Typical signing and pavement markings for residential and minor street terminations are illustrated in **Exhibit 230-13** and described as follows:

- (1) For minor street terminations, include STOP (R1-1), LARGE ARROW (W1-6), and TWO DIRECTIONAL LARGE ARROW (W1-7), signs. Include OBJECT MARKER (OM1-3) as shown and in accordance with **Specification 705** and [Standard Plans, Index 700-010](#).
- (2) For residential street terminations, include DEAD END (W14-1) sign. Include OBJECT MARKER (OM4-3) as shown and in accordance with **Specification 705** and [Standard Plans, Index 700-010](#).

## 230.6.6 Roadway Transitions (2 Lane Undivided to 4 Lane Divided)

Typical signing and pavement markings for roadway transitions from 2-lane undivided to 4-lane divided are illustrated in **Exhibit 230-14** and described as follows:

- (1) Include DIVIDED HIGHWAY (W6-1), DIVIDED HIGHWAY ENDS (W6-2), TWO WAY TRAFFIC (W6-3), DO NOT ENTER (R5-1), KEEP RIGHT (R4-7) and LANE ENDS (W4-2) signs.
- (2) For left roadway centered on existing roadway scheme, include LANE ENDS MERGE LEFT (W9-2L), and RIGHT LANE ENDS (W9-1) signs.
- (3) For right roadway centered on existing roadway scheme, include LANES ENDS MERGE RIGHT (W9-2R), and LEFT LANE ENDS (W9-1L) signs.

## 230.6.7 Channelized Turn Lanes

Typical signing and pavement markings for channelized turn lanes are illustrated in **Exhibit 230-15** and described as follows:

- (1) Include STOP (R1-1) sign.
- (2) For yielding right turn lanes include YIELD (R1-2) sign.
- (3) Include right or left turn lane arrows as applicable.

## 230.6.8 Toll Route Markers

Typical signing and pavement markings for toll routes are illustrated in **Exhibit 230-16a** to **16c** and described as follows:

- (1) Use toll route marker sign panel on the toll mainline.
- (2) Use the Toll Auxiliary Sign in combination with the toll route marker on side streets leading to the toll mainline.
- (3) On numbered routes, use the Toll Route Shield without the additional Toll Auxiliary Sign.

The width of cardinal direction sign, directional arrow auxiliary sign, or other auxiliary sign in the route marker assembly must match the width of the parent route marker sign.

The signs and markers can be found in the [Department's Sign Library](#).

# TYPICAL SIGNING AND PAVEMENT MARKING FOR MIDBLOCK CROSSWALKS

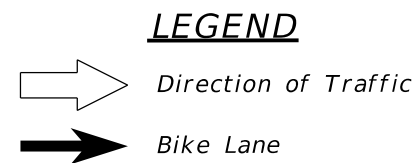
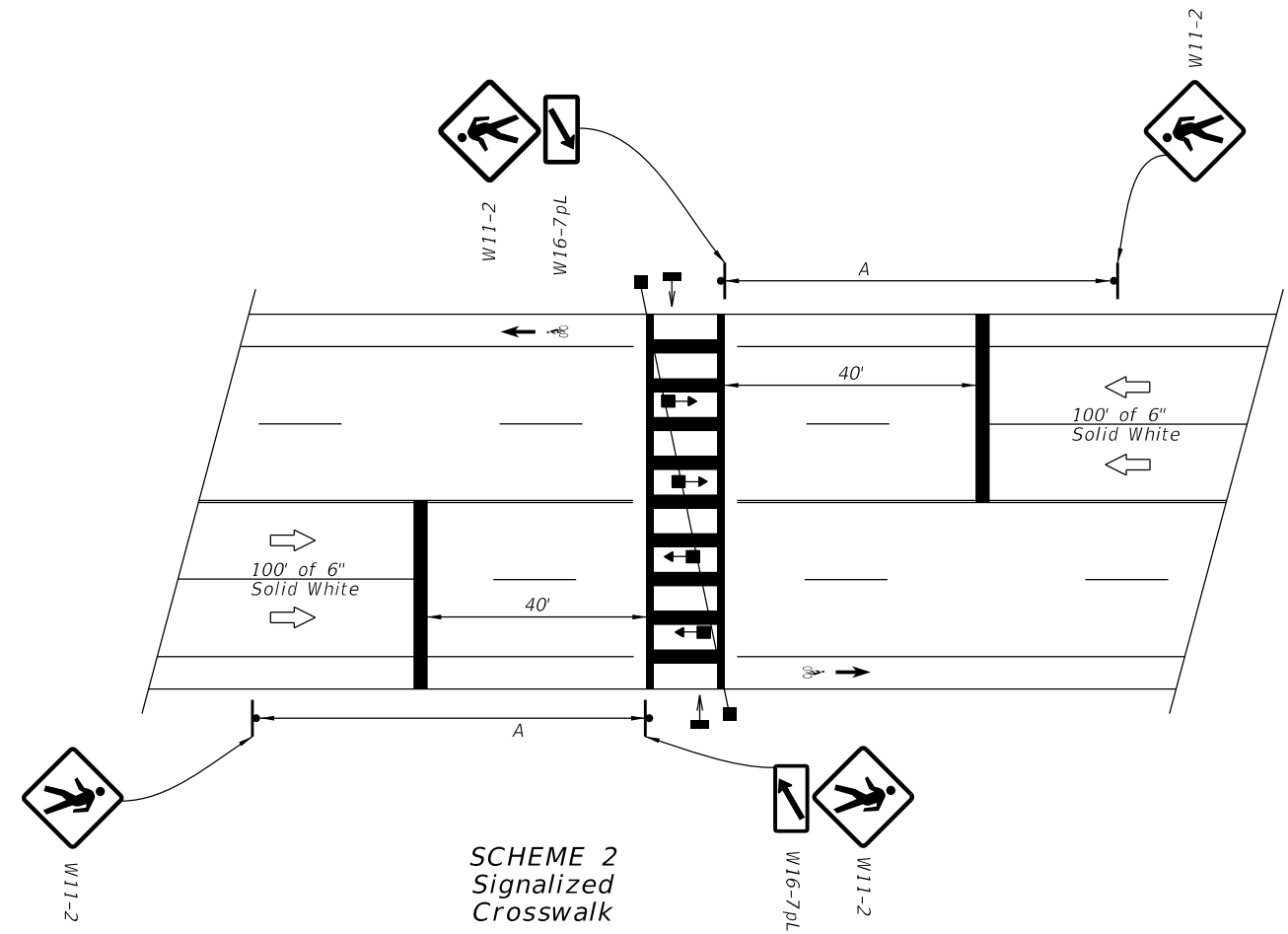
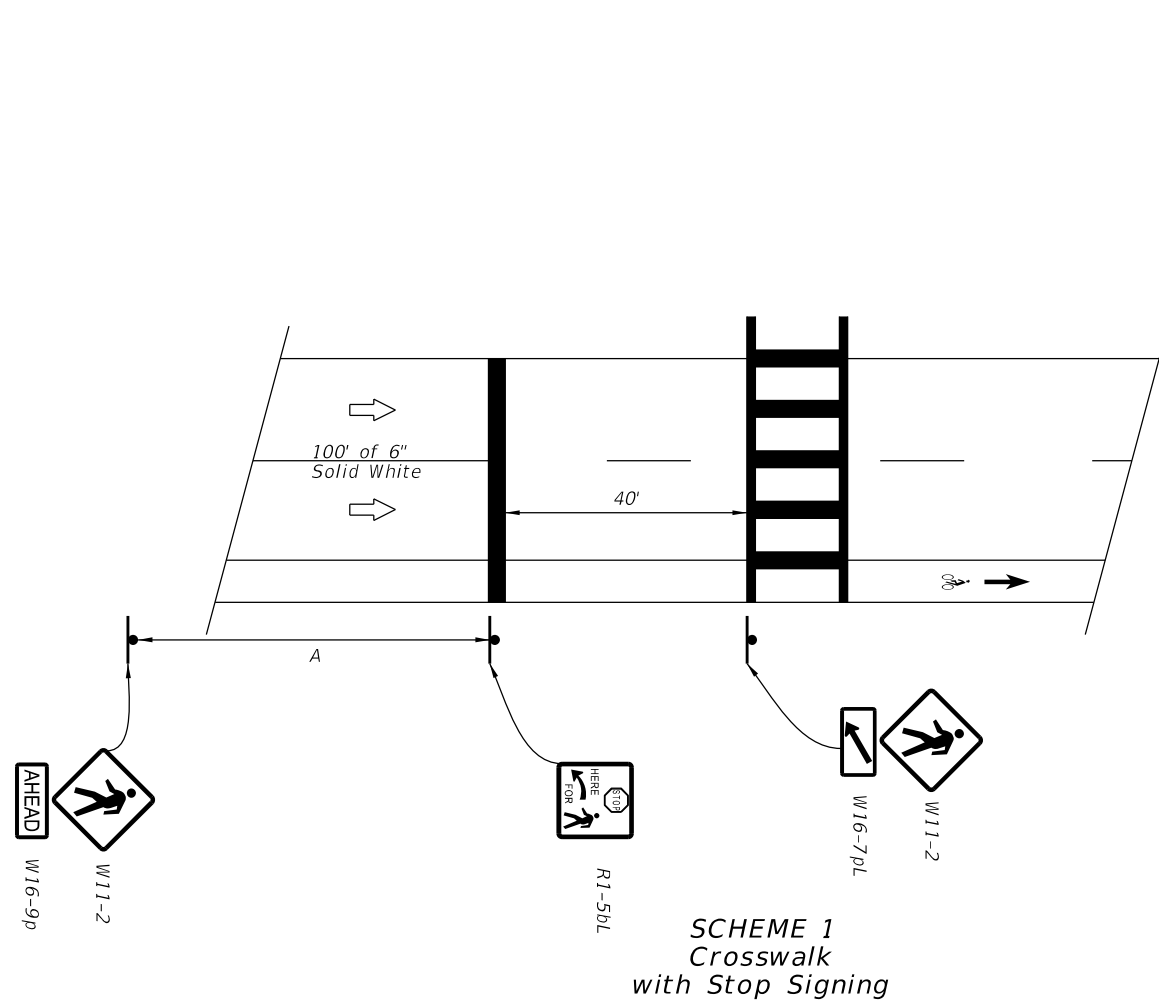

APPROACH SPEED MPH	A-SUGGESTED DISTANCE (Ft.)
25 Or Less	200
26 To 35	250
36 To 45	300

Note:

The details shown do not depict the signing and markings for multi-lane roadways with divided medians. For these applications, additional signs shall be installed on the median side. Minimum width of Mid-Block Crosswalks is 10'.

NOT TO SCALE

EXHIBIT 230-9  
06/01/2021

# TYPICAL SIGNING AND PAVEMENT MARKING FOR FLORIDA NATIONAL SCENIC TRAILS

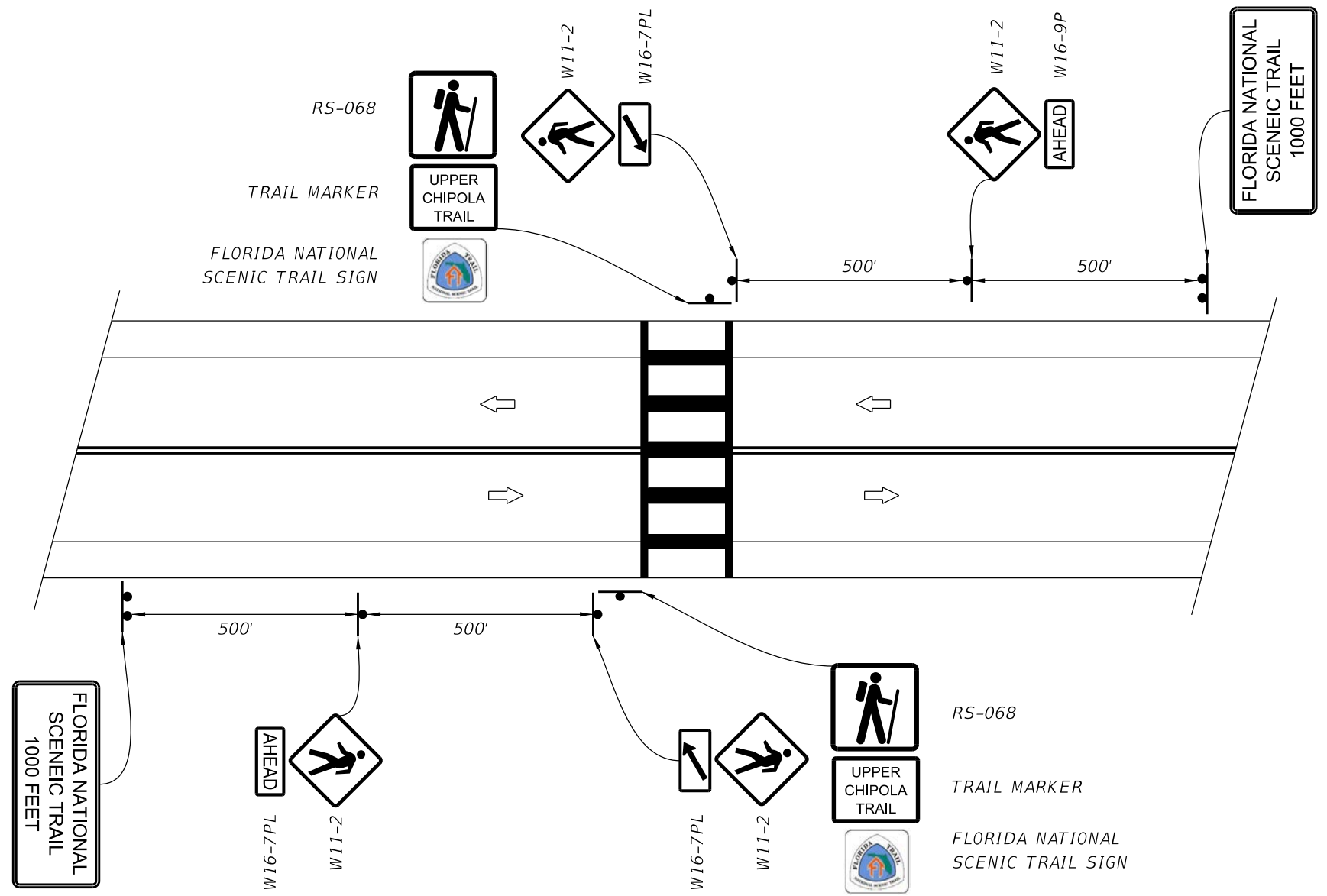

NOTE: The FLORIDA NATIONAL SCENIC TRAIL sign will be provided by the US Forest Service.

**LEGEND**  
 Direction of Traffic



FLORIDA NATIONAL SCENIC TRAIL SIGN

NOT TO SCALE



# TYPICAL SIGNING AND PAVEMENT MARKING FOR AT 4-LEG STOP CONTROLLED INTERSECTIONS ALONG DIVIDED ARTERIALS/COLLECTORS

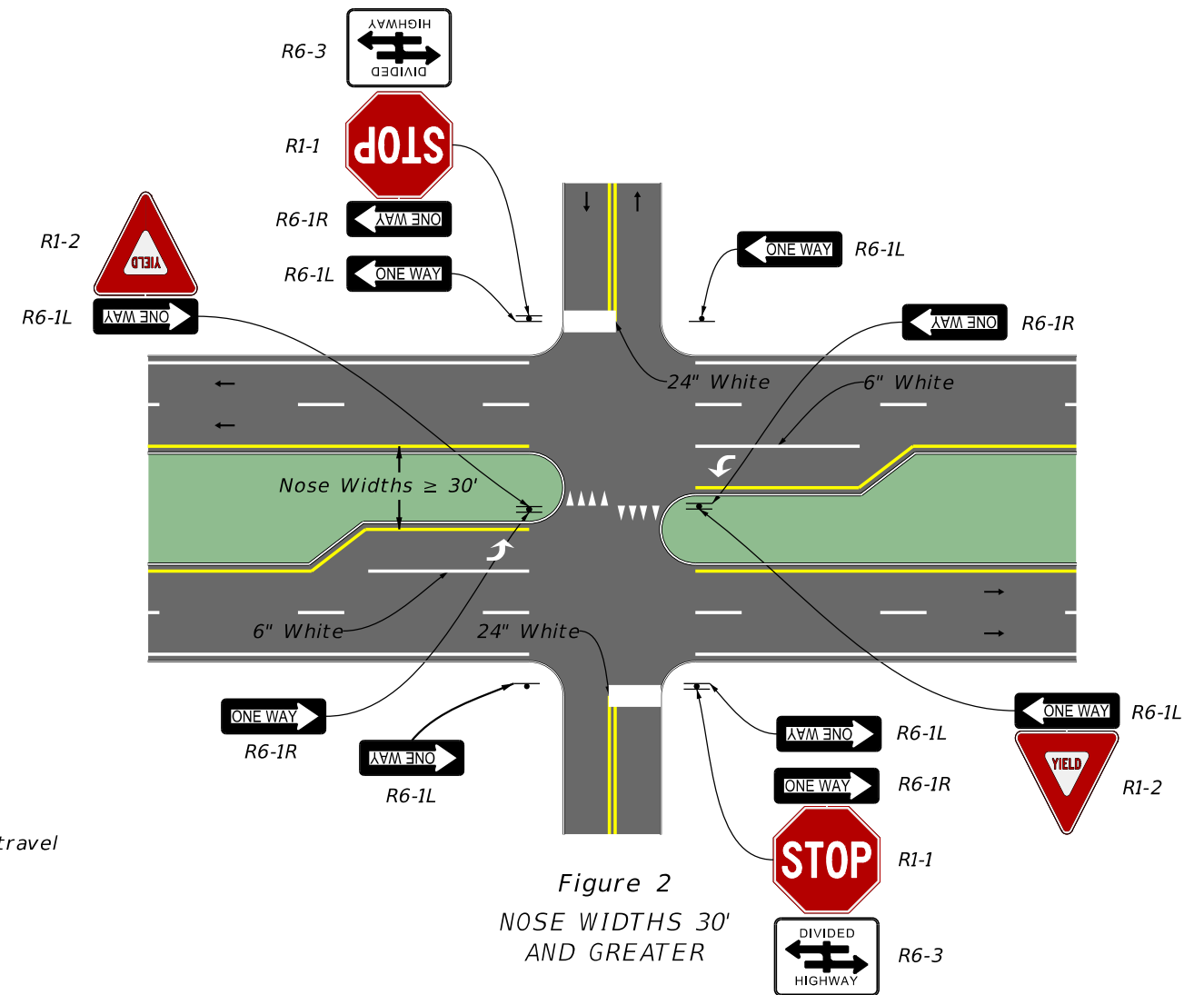
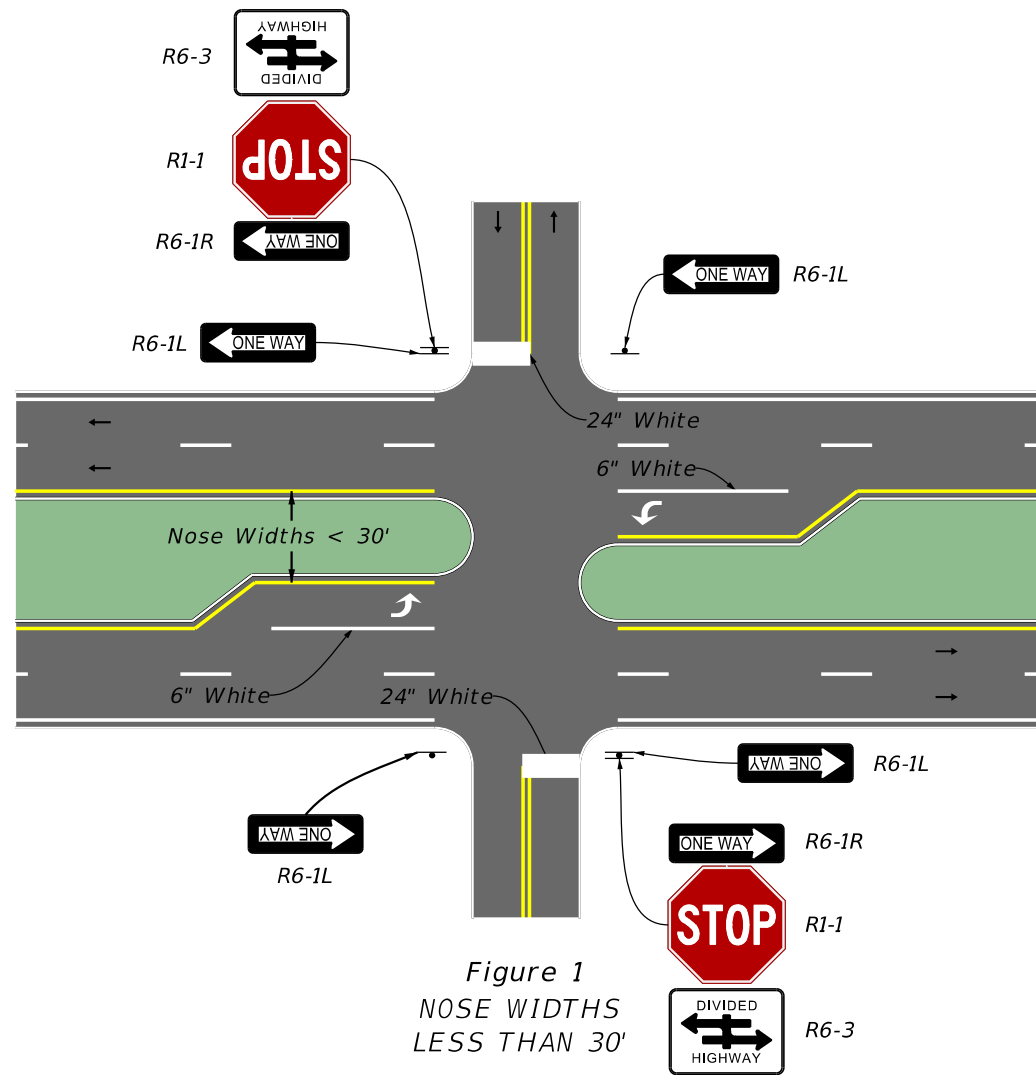

Legend  
→ Direction of travel

## Installation Details

- 1) Divided Highway signs (R6-3) may be on the same structure with the STOP and ONE WAY signs or on a separate structure.
- 2) See the MUTCD and Standard Plans, Index 711-001, for additional pavement marking details.
- 3) For additional signing and pavement marking details to discourage Wrong-Way Driving, see FDM 230.4.3

NOT TO SCALE

EXHIBIT 230-11  
06/01/2021

# TYPICAL SIGNING AND PAVEMENT MARKING AT 3-LEG STOP CONTROLLED INTERSECTIONS ALONG DIVIDED HIGHWAYS

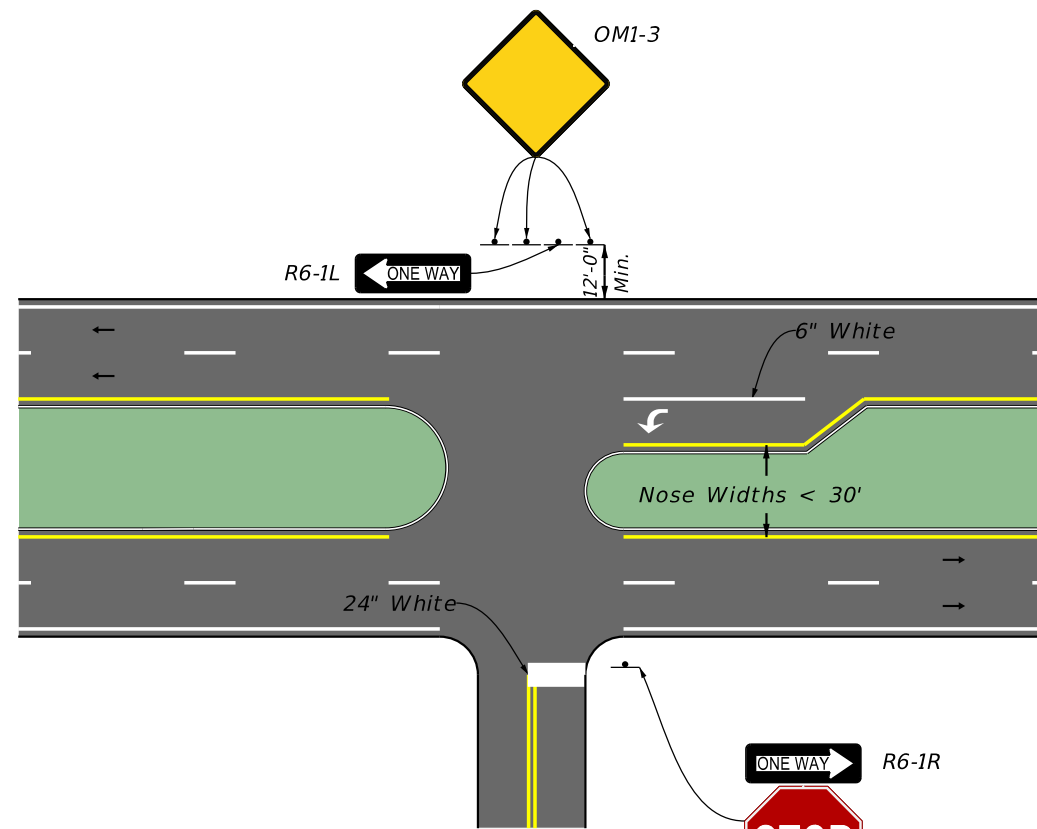

Figure 1  
NOSE WIDTHS  
LESS THAN 30'

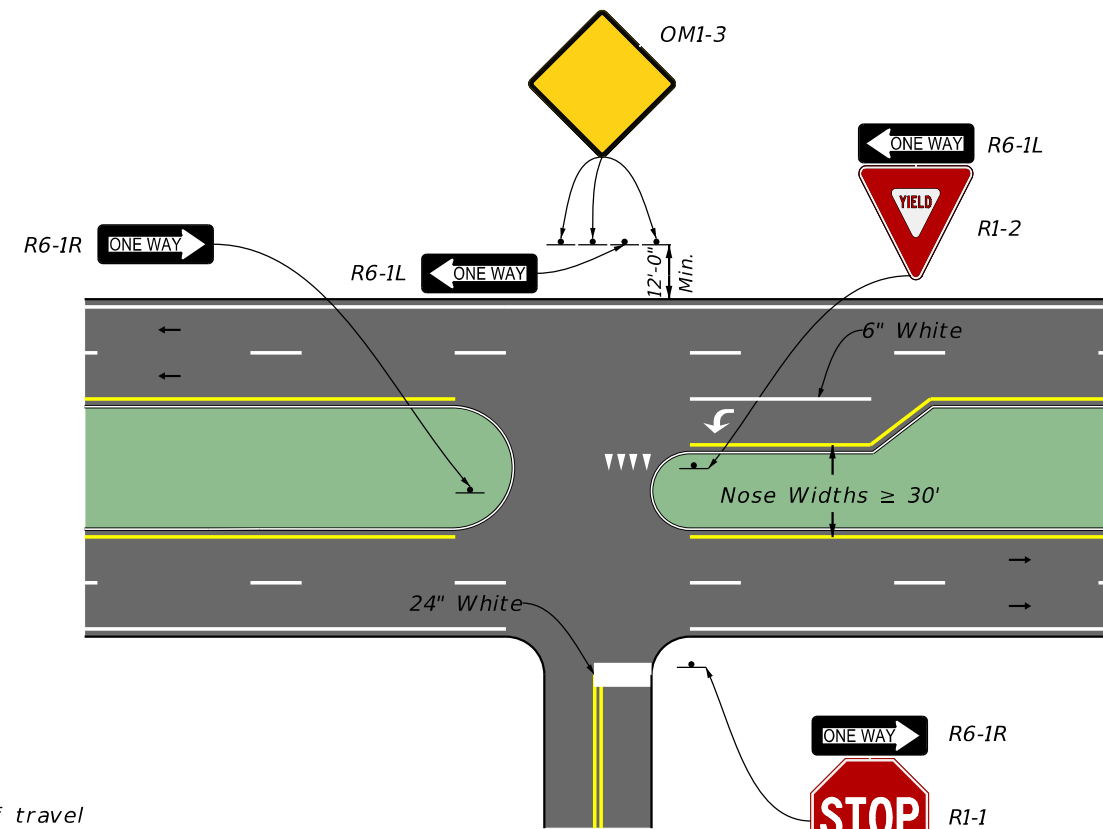

Figure 2  
NOSE WIDTHS 30'  
AND GREATER

Legend  
→ Direction of travel

## Installation Details

- 1) Major streets to be evaluated on a case-by-case basis.
- 2) Install Object Markers in accordance with Index 700-010.
- 3) See Index 711-001 for pavement markings.
- 4) Provide sheeting on signs and object markers in accordance with Specification 993.
- 5) For additional signing and pavement marking details to discourage Wrong-Way Driving, see FDM 230.4.3

NOT TO SCALE

EXHIBIT 230-12  
10/2022

# TYPICAL SIGNING AND PAVEMENT MARKING FOR RESIDENTIAL AND MINOR STREET TERMINATIONS

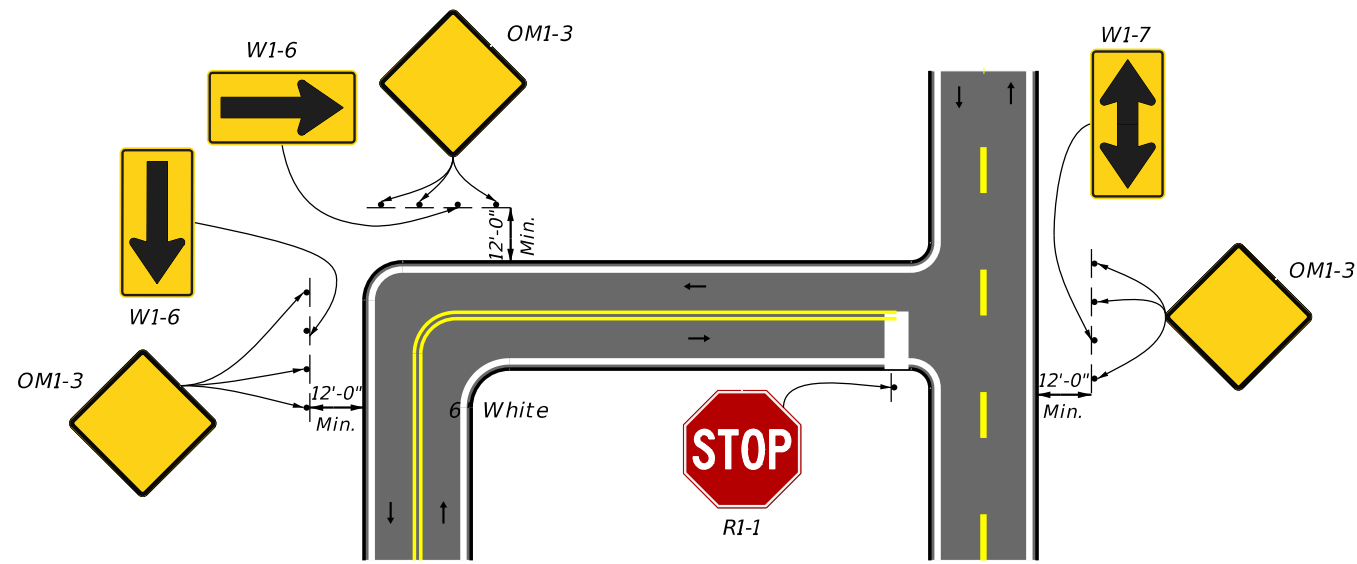

Figure 1  
TRAFFIC CONTROLS FOR MINOR  
STREET TERMINATION

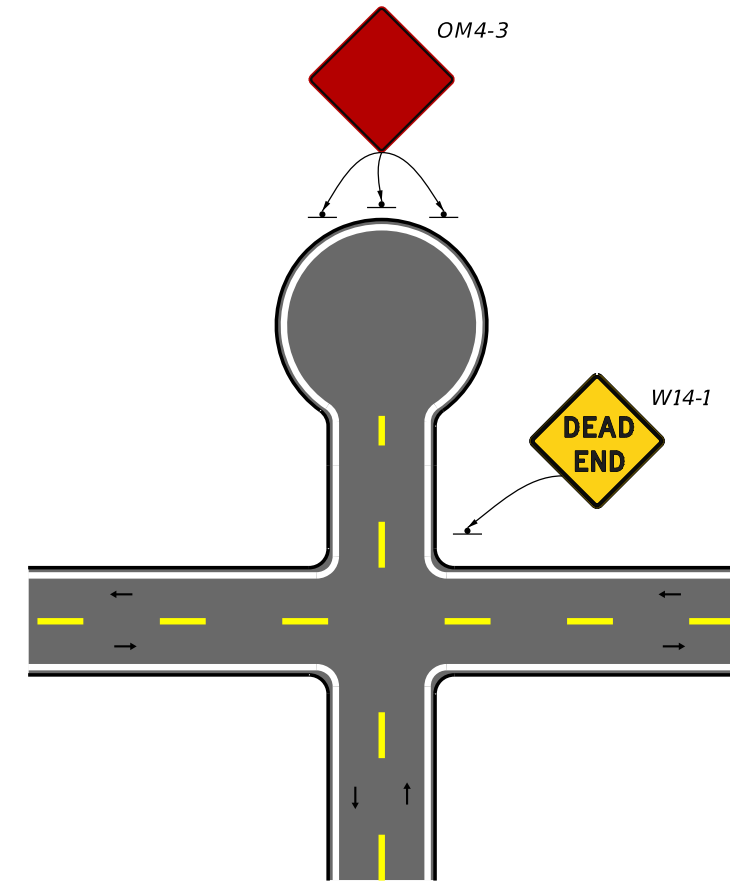
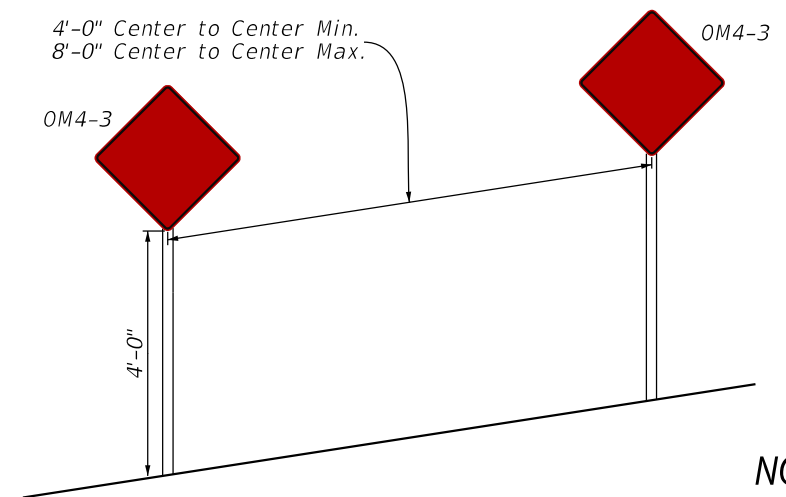

Figure 2  
TRAFFIC CONTROLS FOR  
CUL-DE-SAC OR DEAD END

Installation Details
1) Major streets to be evaluated on a case-by-case basis.
2) Install Object Markers in accordance with Index 700-010
3) See Index 711-001 for pavement markings.
4) Provide sheeting on signs and object markers in accordance with Specification 993.

Legend  
→ Direction of travel



NOT TO SCALE

# TYPICAL SIGNING AND PAVEMENT MARKINGS FOR ROADWAY TRANSITIONS

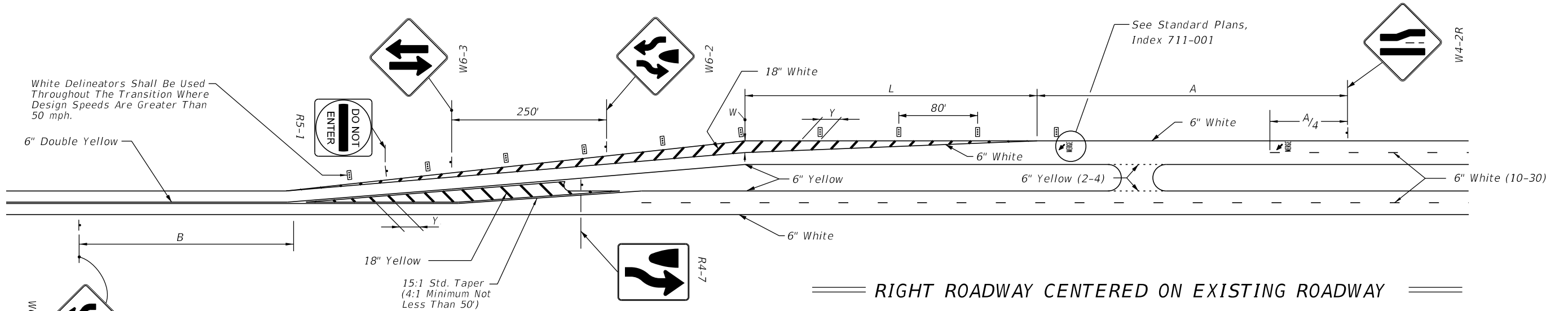
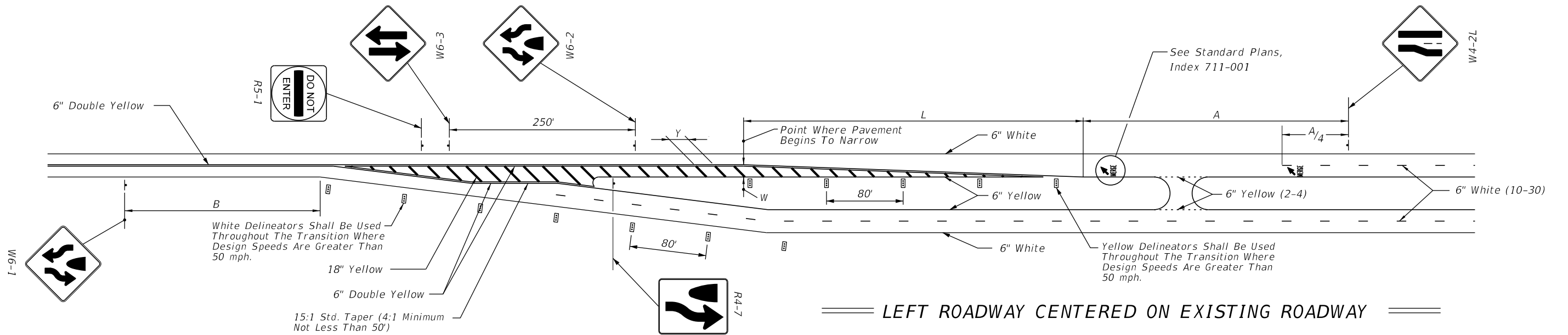

## SCHEMES FOR TRANSITION - 2 LANE / 4 LANE ROADWAY

SPEED MPH	"A" (FT.)	"B" * (FT.)
60	---	640
55	950	595
50	850	550
45	750	500
40	650	455
30	450	365

\* 50' Minimum

POSTED SPEED MPH	"Y" (FT.)
50 OR MORE	40
45	30
40	20
35	20
30 OR LESS	10

DESIGN SPEED 'S' (MPH)	Length 'L' (FT.)
40 or Less	$L = WS^2/60$
45 or Greater	$L = WS$



NOTE: W9-1 & W9-2 are supplemental to the W4-2 sign and may be deleted if space is not available. The W9-1 should be used if only one supplemental sign is installed.

NOT TO SCALE

EXHIBIT 230-14  
01/01/2022

# TYPICAL PAVEMENT MARKINGS FOR CHANNELIZED TURN LANES

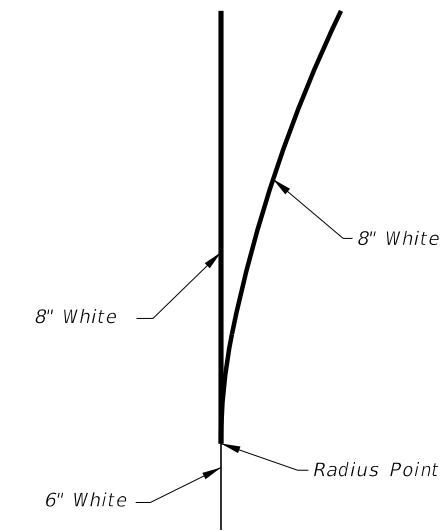
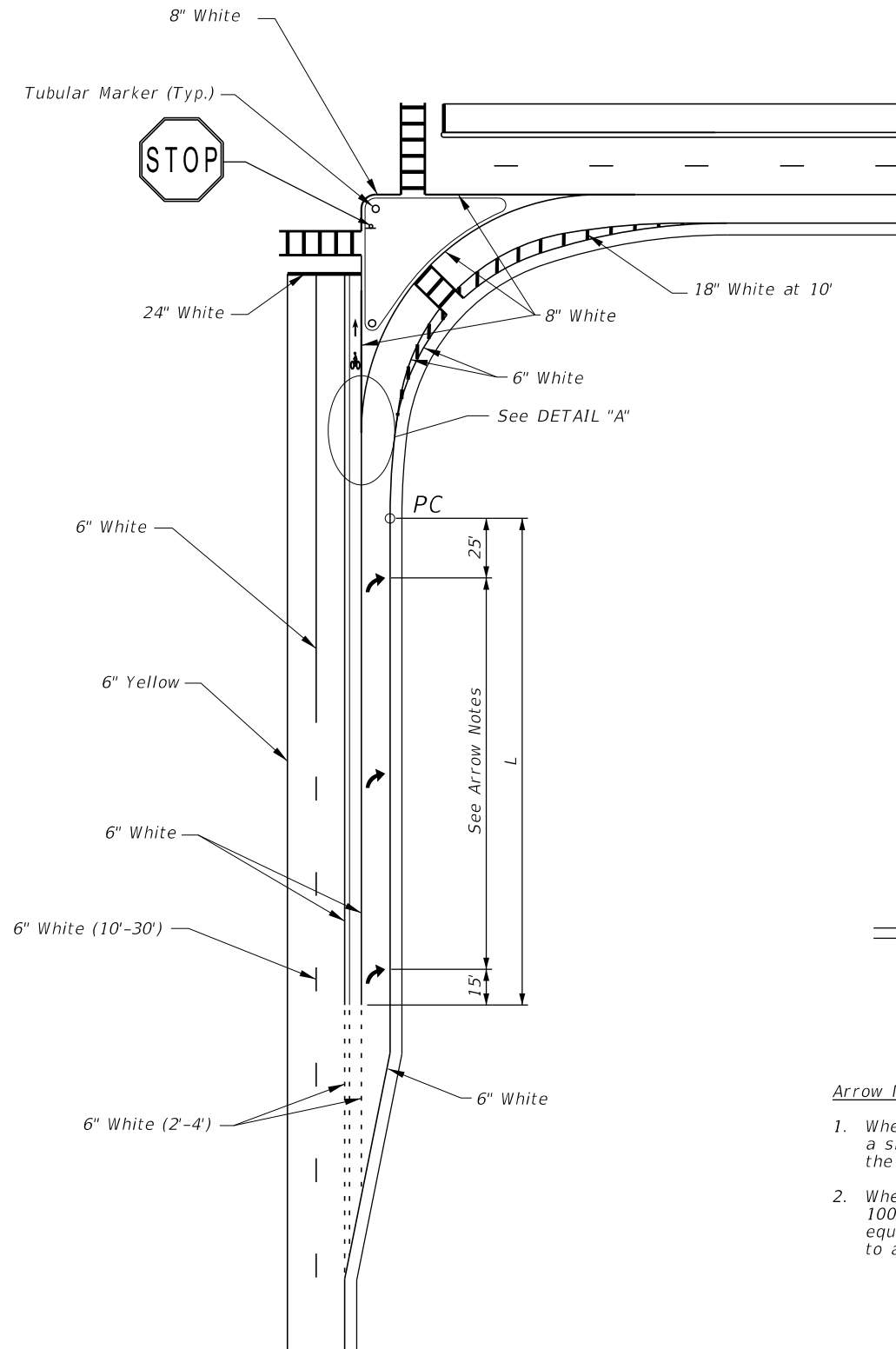
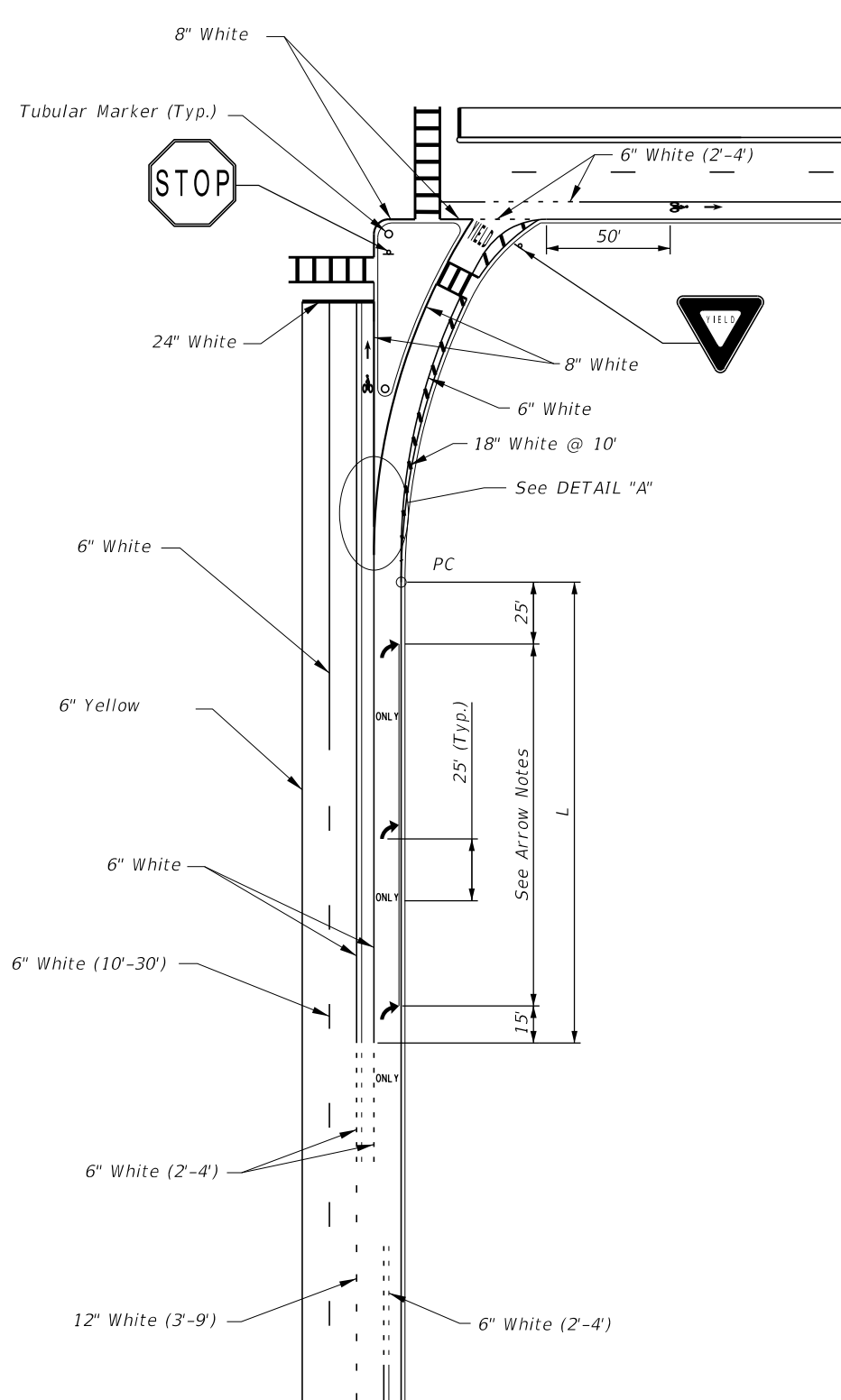

DETAIL "A"

### Arrow Notes

1. When L is less than 100': provide a single arrow located 25' from the PC.
2. When L is greater than or equal to 100': provide the smallest number of equally spaced arrows subject to a maximum spacing of 100'.

RIGHT TURN LANE DROP AND ISLAND DETAILS  
LEFT TURN LANE DROP IS MIRROR IMAGE  
(Showing yielding right turn lane)

RIGHT TURN LANE AND ISLAND DETAILS  
(Showing free flow right turn lane)

NOT TO SCALE

EXHIBIT 230-15  
01/01/2022

# ALL ELECTRONIC TOLLING CONNECTING ROADWAYS TYPICAL SIGNING LAYOUT

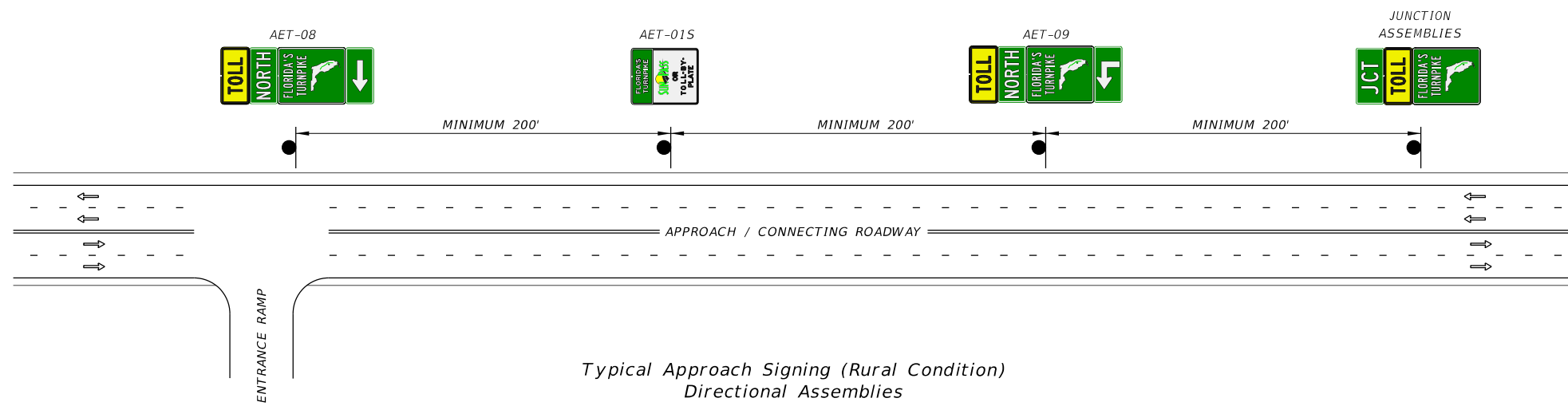
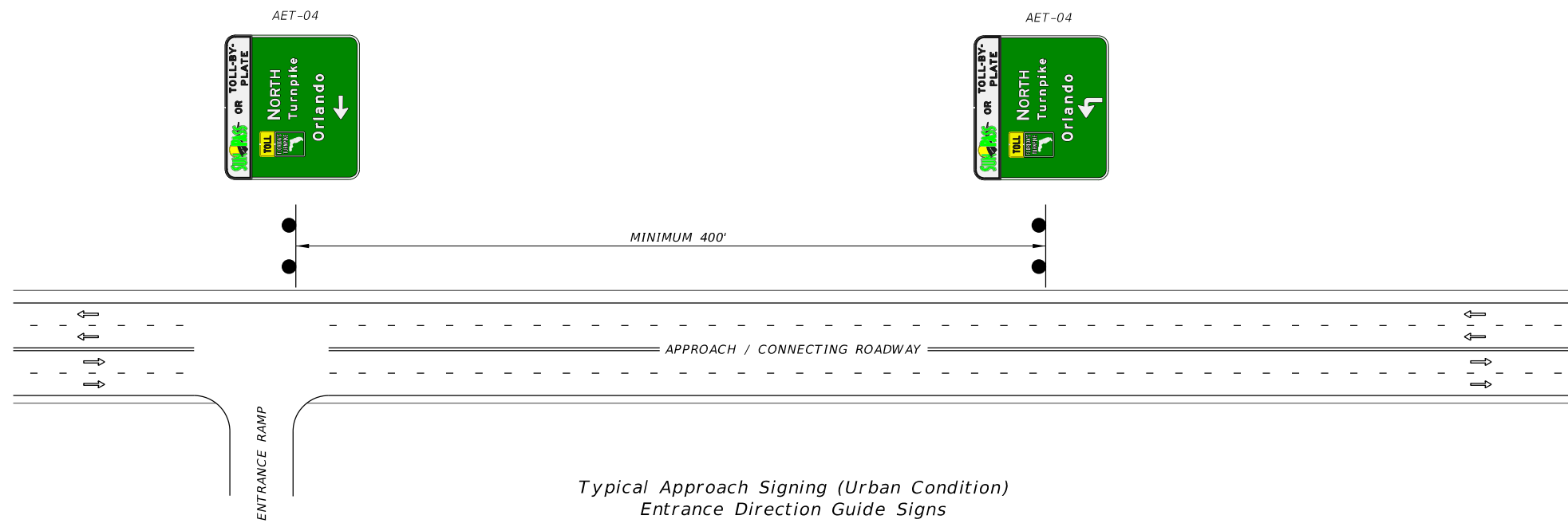

**NOTES:**

1. MINIMUM SPACING DISTANCES FOR SIGNS TO CONFORM TO THE TRAFFIC ENGINEERING MANUAL, AND F.A.C. RULE CHAPTER 14-51, TABLE 1.
2. LEGENDS/MESSAGES SHOWN ON SIGNS AET-04 ARE PROVIDED AS AN EXAMPLE ONLY. ACTUAL DESIGNS SHALL BE SHOWN IN THE PLANS.

NOT TO SCALE

## ALL ELECTRONIC TOLLING ENTRANCE / EXIT RAMP TYPICAL SIGNING LAYOUT

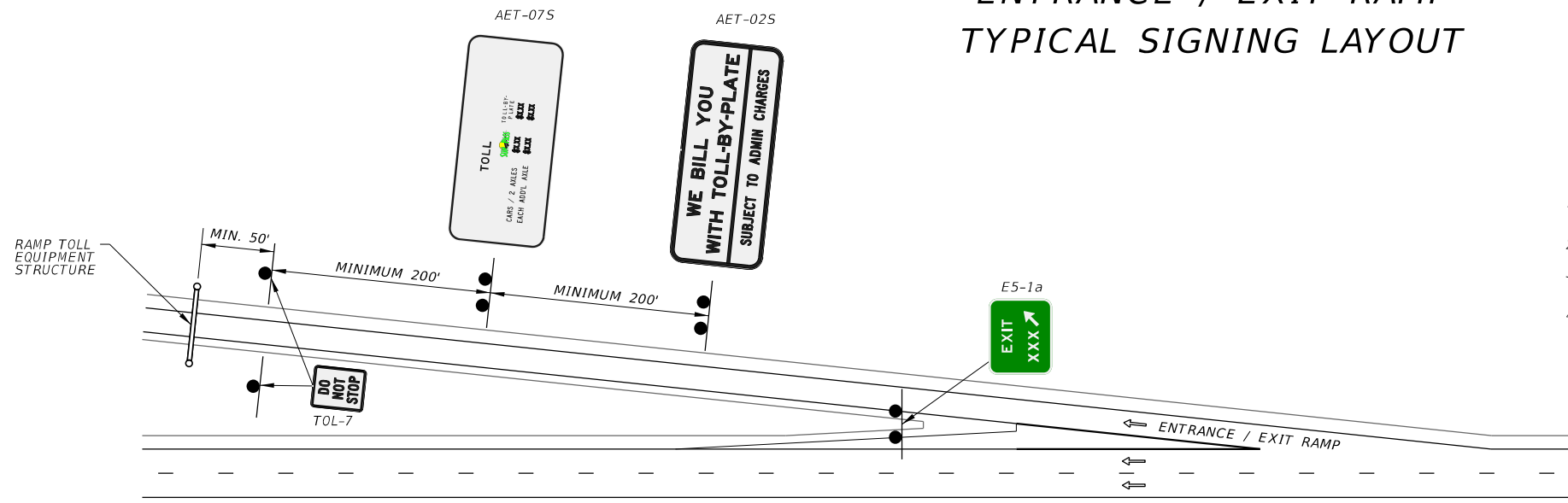

**NOTES:**

1. MINIMUM SPACING DISTANCES FOR SIGNS SHALL CONFORM TO THE TRAFFIC ENGINEERING MANUAL AND F.A.C. RULE CHAPTER 14-51, TABLE 1.
2. TWO TOL-7 (DO NOT STOP) SIGNS ARE REQUIRED PER DIRECTION OF TRAVEL.
3. PLACEMENT OF AET-07S AND AET-02S SIGNS MAY BE BEFORE OR AFTER THE GANTRY, IF FIELD CONSTRAINTS WARRANT IT.
4. STRIPING FOR MULTI-LANE RAMP TOLL SITE MUST CONFORM TO STRIPING SHOWN IN EXHIBIT 230-16c.

Typical Entrance / Exit Ramp Signing  
With Toll Equipment Structure

NOT TO SCALE

EXHIBIT 230-16b  
01/01/2023

## ALL ELECTRONIC TOLLING MAINLINE TOLL TYPICAL SIGNING LAYOUT

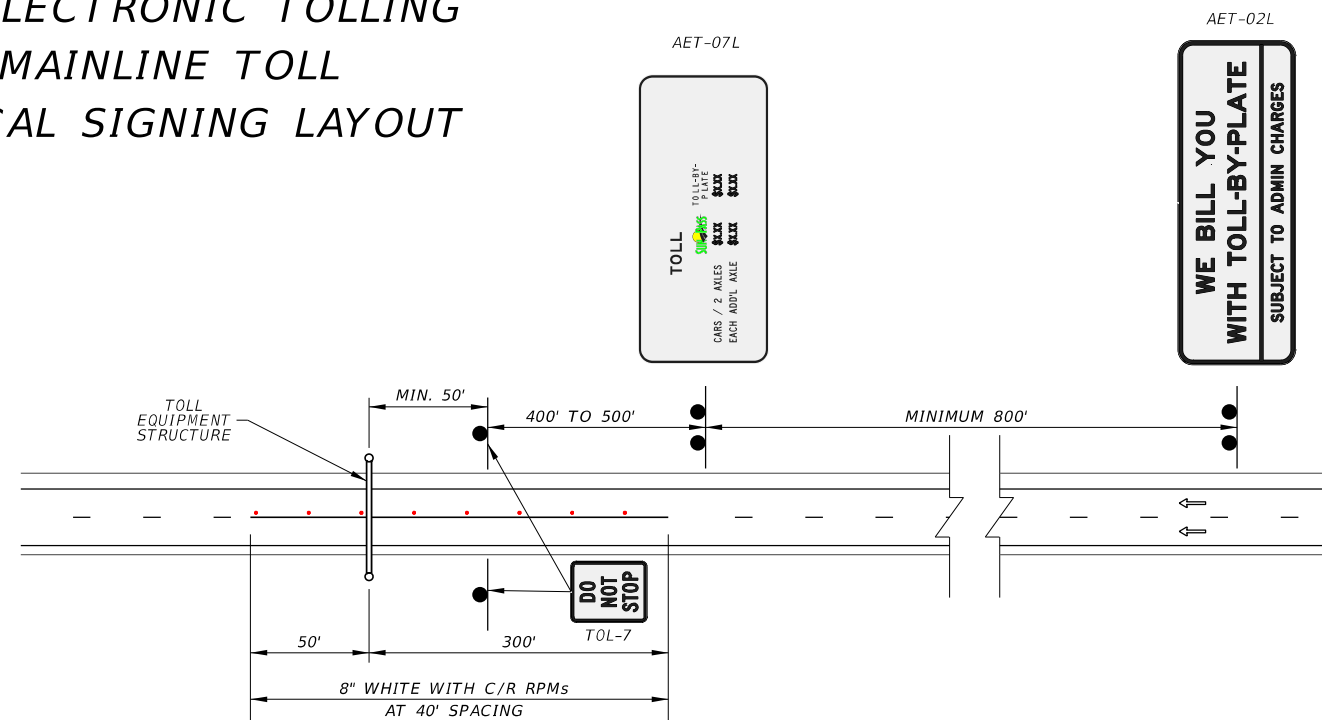

**NOTES:**

1. MINIMUM SPACING DISTANCES FOR SIGNS SHALL CONFORM TO THE TRAFFIC ENGINEERING MANUAL AND F.A.C. RULE CHAPTER 14-51, TABLE 1.
2. TWO TOL-7 (DO NOT STOP) SIGNS ARE REQUIRED PER DIRECTION OF TRAVEL.
3. PLACEMENT OF AET-07L AND AET-02L SIGNS MAY BE BEFORE OR AFTER THE GANTRY, IF FIELD CONSTRAINTS WARRANT IT.

Mainline Toll Equipment Structure

NOT TO SCALE

EXHIBIT 230-16c  
01/01/2023