

917 Stormwater Facilities

917.1 General

A stormwater facility is often located at the downstream end of the drainage system for the purpose of treatment and attenuation of stormwater runoff. The Stormwater Facilities sheet provides data and information for proposed stormwater facilities, including:

- (1) Stormwater Facility Plan View
- (2) Stormwater Facility Sectional Views
- (3) Outlet Structure Details

This sheet may be produced on a standard-format sheet (11"x17") or a large-format sheet (36"x48" or 36"x72"). Use landscape orientation regardless of sheet size selected.

See **Exhibit 917-1** for an example of a Stormwater Facilities sheet.

917.2 Stormwater Facility Plan View

The stormwater facility plan view is typically located in the upper left area of the sheet. It is preferable to display a stormwater facility in its entirety on a single plan sheet. A common horizontal scale for the plan view is 1" = 50' and should not be larger than 1" = 20'.

917.2.1 Required Information

Display and label the following information in the plan view:

- (1) Baseline of construction stationing (typically increasing from left to right) with station and offset ties to the project centerline of construction. Include a north arrow and scale above and near the drainage plan view.
- (2) Elements of the proposed roadway, including drainage pipes and structures.
- (3) Location of stormwater facility sectional views (i.e., A-A, B-B).
- (4) Location of soil borings
- (5) Stormwater facility delineations:

- a) Facility bottom and top (often referred to as Top of Bank). Provide Station/Offset callouts and radiuses along the Top of Bank delineation.
 - b) Change of side slope (e.g., 1:2 to 1:4)
 - c) Maintenance berm limits
- (6) Maintenance access road, fence and gates, and R/W lines
- (7) Stormwater facility drainage structures and pipes with location of outlet structure sectional views (i.e., C-C, D-D)

917.3 Stormwater Facility Sectional Views

The stormwater facility sectional views are typically located below or adjacent to the plan view. Include a minimum of two sectional views, taken in directions perpendicular to each other (as shown on **Exhibit 917-1**). The horizontal scale should be the same as used for the stormwater facility plan view. The vertical scale is typically 4 to 5 times larger than the horizontal scale; e.g., 1" = 20' horizontal and 1" = 4' vertical.

917.3.1 Required Information

Display and label the following information in the sectional views:

- Stormwater facility bottom and top (often referred to as Top of Bank) with elevations, side slopes, and maintenance berm.
- Existing groundline, limits of clearing and grubbing, limits of sod or vegetation, and location of R/W and fence
- Symbols and elevation for Normal Highwater and Peak Design Stage.
- Soil borings

Dimension the maintenance berm, and horizontal distance between stormwater facility delineations.

917.3.2 Cross Sections

Showing cross sections of the stormwater facility in the plans is typically not necessary. However, if it is determined that the sectional views do not adequately show the design intent, cross sections may be included. Place cross sections anywhere within available space on the Stormwater Facilities sheet and include required information specified in **FDM 917.3.1**.

917.4 Outlet Structure Details

The stormwater facility outlet structure details are typically shown adjacent to the plan view. Outlet structure information, elevations, and dimensions may be placed in a data table (as shown on **Exhibit 917-1**) or shown and labeled directly on the outlet structure sectional views. Information, elevation, and dimensions should clearly indicate the fabrication requirement of the modified inlet and skimmers.

917.4.1 3D Isometric View

Provide a 3D isometric view of the stormwater facility outlet structure that illustrates:

- Inlet with weir and drawdown. Provide outlet structure drainage structure number.
- Outlet pipe(s), with pipe number
- Skimmer(s)
- Concrete apron

Placement of the 3D isometric view may use any scale and angle that best displays the various components of the outlet structure.

917.4.2 Sectional Views

Provide a sectional view across each outlet structure side that contains a weir or drawdown. Sectional views must provide all pertinent dimensions and elevations needed to fabricate the outlet structure and at a minimum illustrate the same elements required for the 3D isometric view. Any scale may be used that clearly conveys the requirements of the outlet structure. Elevation data may be provided in table format as shown in **Exhibit 917-1**.

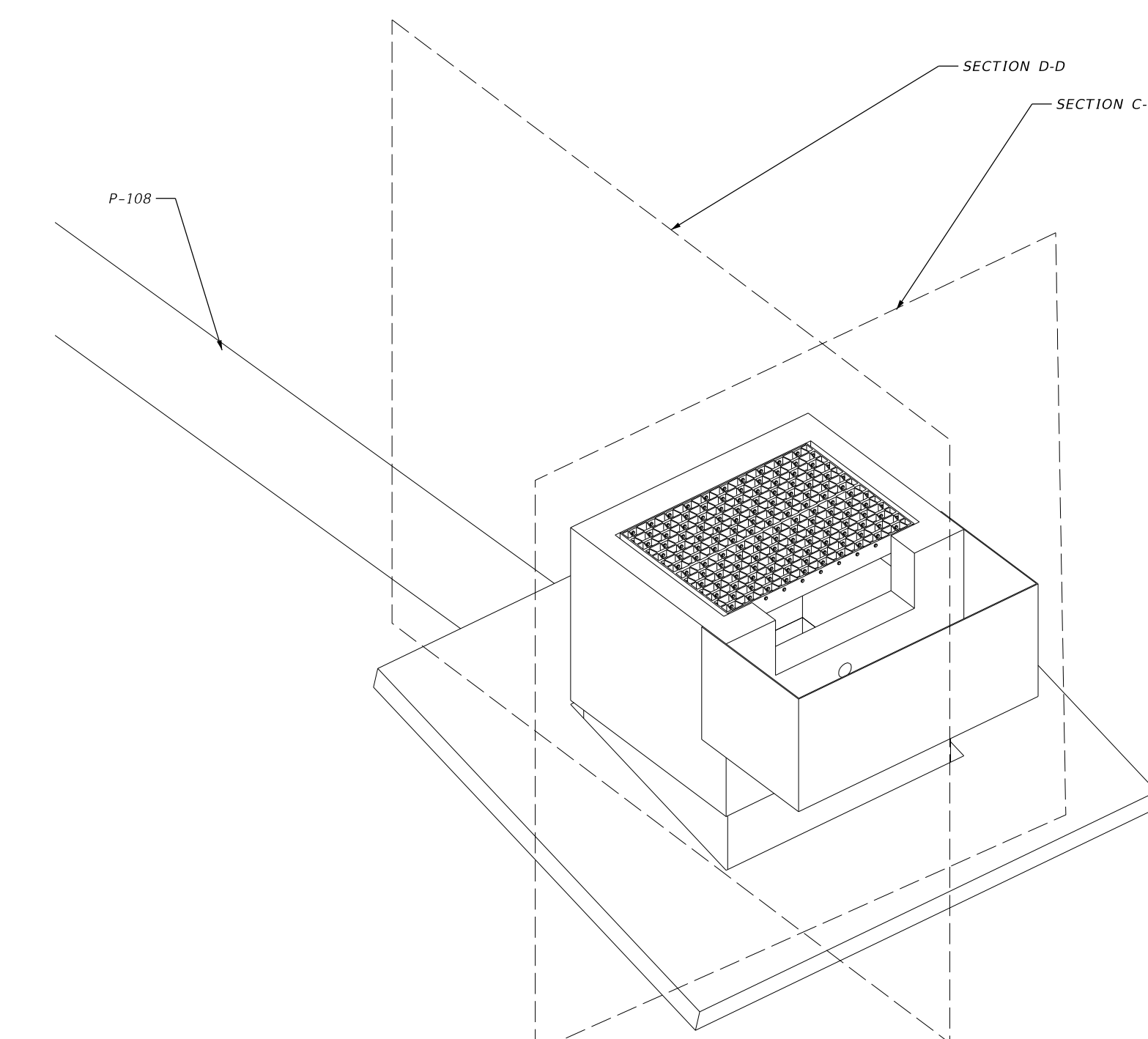
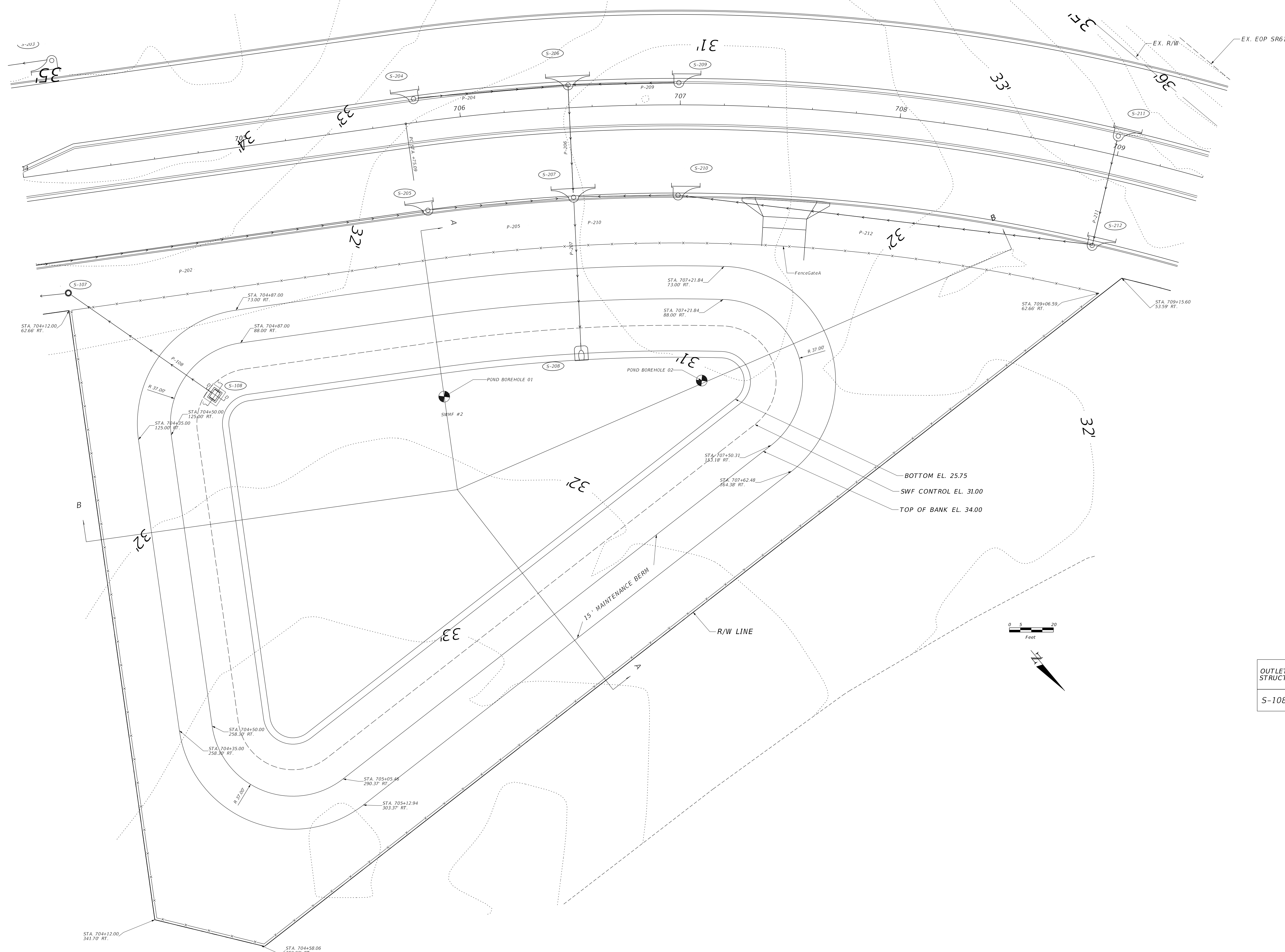

S-108
SWF OUTLET STRUCTURE DETAIL
NTS

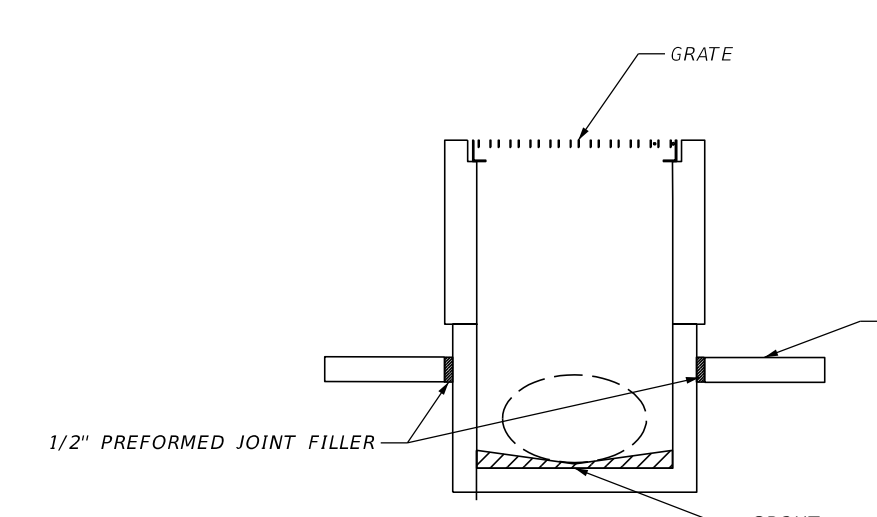

S-108
SECTION C-C
NTS

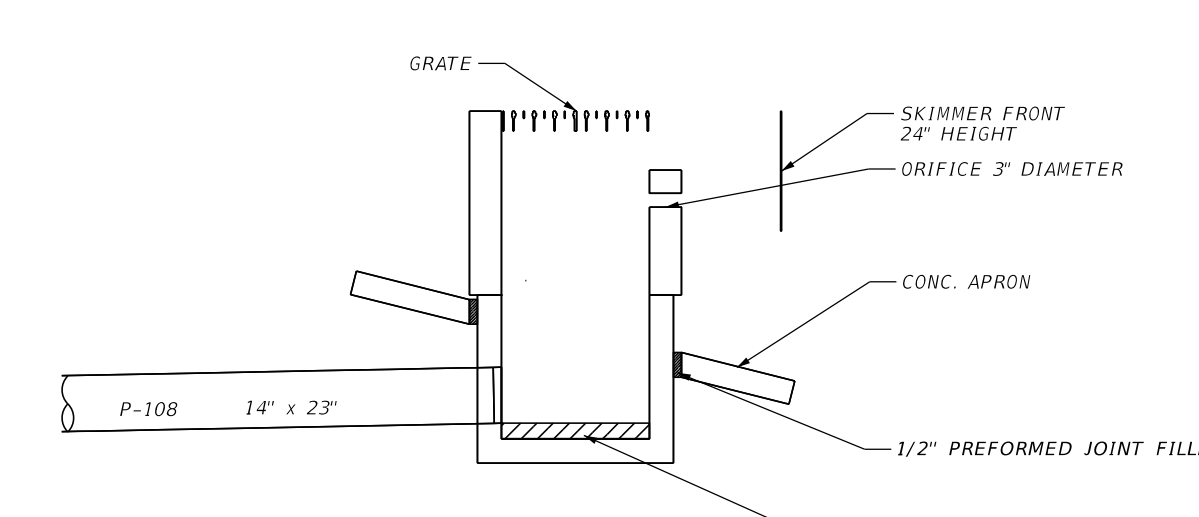

S-108
SECTION D-D
NTS

OUTLET STRUCT.	SWF	STATION	OFFSET	REF.	INLET TYPE	INDEX NO.	GRATE EL. (FT NAVD)	WEIR EL. (FT NAVD)	OUTFALL PIPE EL. (FT NAVD)	ORIFICE EL. (FT NAVD)	CONC. DITCH PAVT. (FT NAVD)	TOP OF SKIMMER EL. (FT NAVD)
S-108	#2	704+72	109.75	SR61	D	425-052 425-070	33.00	32.00	29.20	31.00	10.91	33.00

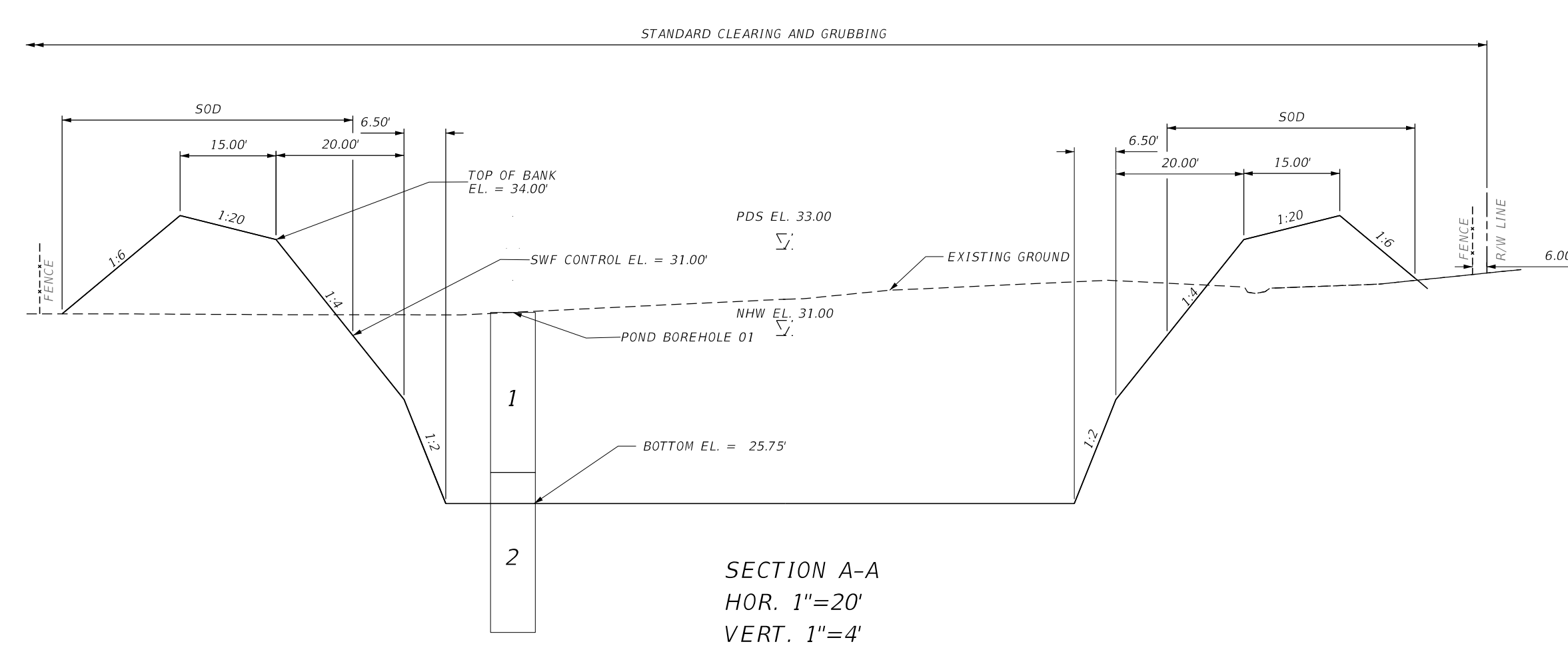

SECTION A-A
HOR. 1"=20'
VERT. 1"=4'

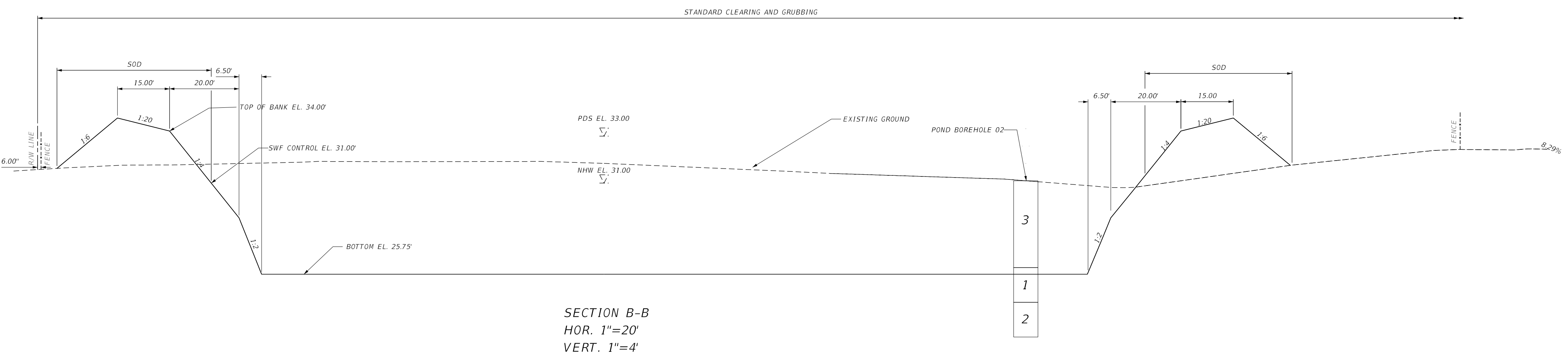

SECTION B-B
HOR. 1"=20'
VERT. 1"=4'

EXHIBIT 917-1
Date 1/1/21