

Summary of Updates: 2021 FDOT Design Manual

FDM 100 (Introduction)

Commentary on Update: On 9/8/2020 by Gevin McDaniel.

Date of presentation:

- 100 (1) – Organization

1. ORGANIZATION

Background

In January 2018, the **FDM** is replacing-replaced the Plans Preparation Manual (PPM) that has circulated since January 1998.

Organization

The **FDM** is a ~~three~~four-part manual. **Part 1** contains development and processes, **Part 2** contains design criteria, and **Part 3** contains material concerning traditional plans preparation and assembly. **Part 9** is currently under development to provide material concerning the preparation and assembly of model-centric plans.

34. DEVELOPMENTAL DESIGN CRITERIA

Developmental Design Criteria (DDC) provides a process for the Department to develop future **FDM** criteria for new or innovative design concepts and technologies.

A Design Memorandum will be released to notify the Districts of the initial availability of each **DDC**.

The **DDC** are published separately from the **FDM**; however, they will be listed with hyperlinks to the **DDC** on the **FDM** webpage along with the **FDM** chapters.

A Central Office Monitor (Monitor) is assigned to each **DDC**. The Monitor oversees the development of the criteria, monitors the use of the **DDC** on projects, and makes changes/updates as needed.

The **DDC** must be used to the extent practicable on projects containing the applicable design elements; however, must not adversely affect the production schedule. Determination of applicability versus project schedule is at the discretion of the District Design Engineer. Include the Monitor as a lead reviewer in the Electronic Review Comments (ERC) system when the **DDC** is used.

The Department's Design Variation process is not applicable to **DDC**. When requesting deviations from **DDC**, designers must contact the assigned Monitor to obtain written approval. Written approvals for deviations will be used by the Monitor to further develop **DDC** language. Designers are not required to submit written documentation when requesting deviations. The sole purpose of this process is to aid the Monitor in understanding the challenges faced by designers in following the **DDC**.

Revisions to ~~these~~ **DDC** may be made by the Department at any time and the last revision date will be noted within each chapter. Revisions to **DDC** are not retroactive for projects where the design effort for applicable design elements is substantially complete as determined by the District Design Engineer.

Modification for Non-Conventional Projects:

Delete item 4 above and see the RFP.

FDM 102 (Glossary of Terms)

Commentary on Update: On 9/4/2020 by Gevin McDaniel.

Date of presentation:

- 102.2 – FDM Definitions

▪ **Blended Transitions**

~~Blended transitions dthe at the level of the sidewalk or shared use path a grade of 5% or less. Blended transitions can be used when.~~

~~Blended transitions are areas where the elevation of a roadway and that meets the a sidewalk, or shared use path, are the same along the width of a pedestrian crossing. Blended transitions can vary in geometrics, but require detectable warnings in the same locations that a curb ramp would. For flush shoulder roadways, blended transitions are the portion of the sidewalk, or shared use path, that meets the traveled way, bicycle lane, or paved shoulder. For curbed roadways, blended transitions are elevation transitions of the roadway such as Blended transitions are the portion of the sidewalk or shared use path that meets the travel lane or paved shoulder on flush shoulder roadways, or a raised crosswalk, raised intersection, or depressed corner. Detectable warnings must be placed in the same locations as that of a curb ramp, or similar types of elevation transitions on curbed roadways.~~

FDM 103 (Standard Forms)

Commentary on Update: Added items to the list of Form 121-A on 8/4/2020.

Date of presentation: 7/30/2019 via email per Ben Goldsberry

- 103.1 – General (Form 121-A)

ITEMS	STATUS ^(b)
1. Typical Sections for Roadway and Bridge ^(a)	<u>Select Status</u>
2. Roadway Plans in Vicinity of Bridge ^(a)	Select Status
3. Maintenance of Traffic Requirements ^(a)	Select Status
4. Bridge Hydraulics Report ^(c)	Select Status
5. Geotechnical Report ^(c)	Select Status
6. Bridge Corrosion Environmental Report ^(c)	Select Status
<u>7. GRS Abutments Feasibility Assessment^(d).....</u>	Select Status
<u>8. Precast Feasibility Assessment.....</u>	Select Status
7.9. <u>7.</u> Existing Bridge Plans	<u>Select Status</u>
.....	<u>Select Status</u>
8.10. <u>8.</u> Existing Bridge Inspection Report
.....
9.11. <u>9.</u> Existing Bridge Load Rating	Select Status
<u>12. Wildlife Connectivity.....</u>	Select Status
10.13. <u>10.</u> Utility	Select Status
Requirements.....	Select Status
11.14. <u>11.</u> Railroad Requirements	Select Status
.....	Select Status
12.15. <u>12.</u> Retaining Wall and Bulkhead
Requirements.....
13.16. <u>13.</u> Lighting Requirements
.....
14.17. <u>14.</u> ADA Access Requirements	Select Status
15.18. <u>15.</u> Other.....	Select Status
.....
<p>(a) Must be approved by District before BDR submittal. (b) Select appropriate status: Provided, Not Applicable, Comments Attached (c) See approval requirements for these documents in FDM 121. (e)(d) <u>GRS = Geosynthetic Reinforced Soil</u></p>	

Commentary on Update: On 5/14/2020 again on 8/25/2020 by Systems Implementation.

Date of presentation:

- 103.1 – General (Form 126-A)

INITIAL MEETING CHECKLIST AND METHODOLOGY CHECKLIST

This is a list of items that the Applicant should prepare the following list of items to discuss at the initial meeting, and the District Review Team may require the Applicant to address these items in the Concept Report, as needed.

Project Basic information about the project

- | | |
|---|--|
| <input type="checkbox"/> Project Location | <input type="checkbox"/> Jurisdiction(s) in which the Project is Located |
| <input type="checkbox"/> Project Limits | <input type="checkbox"/> Proposed Change in Lane Configuration |
| <input type="checkbox"/> Project Length | <input type="checkbox"/> Project Schedule |
| <input type="checkbox"/> Project Purpose | <input type="checkbox"/> Context Classification |

This is a list of items that the Applicant should be prepared to discuss at the Initial Meeting:

- Conceptual plan (including transitions to and from the lane-elimination repurposing section)
- Existing and long-range future AADT (the latter based on historical growth and the regional travel demand model, if applicable)
- Consistency of the proposed project with the applicable Long-Range Transportation Plan (LRTP), Transportation Improvement Program (TIP), Transit Development Plan (TDP), comprehensive plan, master plans, visions, and Complete Streets initiatives
- Status of the roadway as an Evacuation Route, freight route, and part of the Strategic Intermodal System (SIS)
- Status of the roadway as a major transit corridor per the LRTP or TDP
- Proposed use(s) for the right-of-way after lanes are eliminated (e.g., widened sidewalks, bicycle lanes, landscaping, on-street parking, transit lanes)
- Impact on bicycle/pedestrian infrastructure and connectivity
- Impact on parking
- Impact on transit routes, stop locations (including appropriateness of turn radii and lane widths), include total number of stops and routes in the area.
- Existing right-of-way width and any proposed changes to the right-of-way width
- Anticipated changes (if any) in jurisdictional responsibility for ownership or maintenance of the roadway
- Anticipated changes (if any) in functional classification and/or access management classification
- Public Involvement, agency outreach and endorsement, Anticipated changes (if any) in functional classification and access management classification
- Existing design and posted speeds
- Existing and future typical section
 - Target speed with
- Anticipated changes (if any) in posted speed limits and design speeds
- Need for design variations or design exceptions to support the lane-elimination project
- Plan for obtaining input and review from businesses, residents, and other stakeholders
- Plan for receiving endorsement from elected officials
- Funding source and cost estimates
- Size of impact area-parallel and cross streets
- Potential implementation strategy and partner commitments
- Impact on School crossing locations and midblock crossing
- Need to add, remove, or modify traffic signals
- Near and long-range multimodal level of service (LOS) and queuing analysis for intersections and segments in the impact area under build and no-build scenario
- Mitigation to address the significant adverse impact on state roads and regional transportation system
- Crash data summary and analysis for the segments and intersections within

the project limits

Case-specific special considerations to be determined (e.g., railroad crossing improvements)

- 103.1 – General (Forms 126-B)

Form 126-B

Methodology Checklist

This is an illustrative list of items that the District Review Team may require the Applicant to address in a Concept Report, as needed:

- | | |
|--|---|
| <p><input type="checkbox"/> Conceptual design plans (including proposed typical sections) that meet FDOT design standards for all transportation modes</p> <p><input type="checkbox"/> Need for any design variations or exceptions</p> <p><input type="checkbox"/> Size of impact area</p> <p><input type="checkbox"/> Near- and long-range traffic forecasts with and without the proposed (with changes in travel patterns clearly shown)</p> <p><input type="checkbox"/> Near- and long-range level of service (LOS) and queuing analysis for intersections and segments in the impact area under the build and no-build scenarios</p> <ul style="list-style-type: none"> • LOS analyses may be daily or peak hour analyses at the District Review Team's discretion. • The District Review Team and the Applicant should agree on an analysis methodology. <p><input type="checkbox"/> Mitigation to address significant and adverse LOS impacts on State roads and the regional transportation system resulting from the lane elimination</p> <p><input type="checkbox"/> Impact on pedestrian and bicycle infrastructure (e.g., sidewalks, bicycle lanes, and multi-use paths) and connectivity</p> <p><input type="checkbox"/> Impact on transit routes and transit stops locations (including appropriateness of turn radii and lane widths)</p> <p><input type="checkbox"/> Impact on parking supply</p> | <p><input type="checkbox"/> Crash data summary and analysis, which may include identification of high-crash locations (by crash type) and locations on FDOT's 5% lists (i.e., the lists of the 5% of segments and intersections with the highest number of crashes) and estimation of the potential increase or decrease in crashes using Crash Modification Factors (CMFs) from the Highway Safety Manual, CMFs from the FHWA CMF Clearinghouse website, or other appropriate methodologies</p> <p><input type="checkbox"/> Impact on trucks and designated truck routes (including appropriateness of turn radii and lane widths and possible relocation of designated truck routes)</p> <p><input type="checkbox"/> Impact on evacuations routes and emergency response</p> <p><input type="checkbox"/> Conceptual funding plan (includes cost estimates and funding sources)</p> <p><input type="checkbox"/> Conceptual implementation plan (including an implementation schedule and a list of the commitments that the applicant will make in support of the lane elimination project)</p> <p><input type="checkbox"/> Existing posted speed and desired posted speed after the lane elimination</p> <p><input type="checkbox"/> The need to add, remove, or modify traffic signals</p> <p><input type="checkbox"/> Impacts on school crossing locations and/or midblock pedestrian crossing locations</p> <p><input type="checkbox"/> Case-specific special considerations to be determined (e.g., railroad crossing improvements)</p> |
|--|---|

LANE ~~ELIMINATION~~ REPURPOSING INITIAL NOTICE TO CENTRAL OFFICE

To: _____ From: _____ Date: _____
Systems Management Administrator *District Lane Elimination Coordinator*

The intent of this notice message is to inform Central Office that District _____ has received a request for lane repurposing elimination on the State Highway System.

PROJECT INFORMATION

State Road and Project Location: _____

_____ Project Location: _____

_____ Roadway ID: _____

_____ Context Classification: _____

Project Limits (MP): ~~:-f~~ From _____

to _____

Roadway ID: _____ Project Limits (MP): from _____ to _____

Context Classification: _____

Applicant: _____

Project Description: _____

Proposed Change in Cross Section: From _____ lanes to _____ lanes

SIS NHS

ACTIONS AND OUTCOMES TO DATE

District staff participated in a meeting with _____ on _____ to formally commence the lane repurposing elimination review process. At that meeting, District staff provided an overview of the lane repurposing elimination review process and the Applicant shared initial information about the lane repurposing elimination project. The District determined the specific review process and analysis methodology for the lane repurposing elimination request.

NEXT STEPS

The Applicant will submit a Draft Concept Report (containing a proposed typical section) as the lane repurposing elimination review process proceeds. If the District reviewers find the Draft Concept Report acceptable, ~~the District will recommend that the Applicant submits~~ a formal Application Package (including the Final Concept Report) to the District. If the Application Package is complete and acceptable, the ~~District will approve the lane~~ repurposing elimination request will be approved at the District level. The Final Application Package along with signed Form-C will be sent to with the concurrence of Central Office for final approval.

LANE LANE REPURPOSING FINAL REVIEW AND APPROVAL NOTICE TO CENTRAL OFFICE

The intent of this notice is to inform Central Office that District _____ has completed the review for the following lane repurposing project on the State Highway System.

PROJECT INFORMATION

State Road and Project Location: _____

Roadway ID: _____ Project Limits (MP): From _____ to _____

Roadway ID: _____ Project Limits (MP): From _____ to _____

Context Classification: _____ Access Management Classification: _____

Target Speed: _____ Design Speed: _____ Posted Speed: _____

Transit facilities (stops and routes): Yes No

Applicant: _____

Project Description: _____

Proposed Change in Cross Section: From _____ lanes to _____ lanes

SIS NHS

Attachments: Concept Report Plan views Typical sections

~~Elimination FINAL REVIEW AND APPROVAL~~

NOTICE TO CENTRAL OFFICE

The intent of this message is to inform Central Office that District _____ has received a request for lane elimination on a State Highway.

PROJECT INFORMATION

State Road: _____

Project Location: _____

Roadway ID: _____

Context Classification: _____

Project Limits (MP): From _____ to _____

Applicant: _____

Project Description: _____

Proposed Change in Cross Section: From _____ lanes to _____ lanes **Form 126-**

SIS NHS

District Concurrences:

District Planning and Environmental Administrator

Date: _____

District Design Engineer

Date: _____

District Traffic Operations Engineer

Date: _____

Central Office Concurrence:

Chief Planner

Date: _____

Final Approval:

Chief Engineer

Date:

Commentary on Update: Fully removed Forms 131-A, B & C on 8/3/2020 due to being modified.

Date of presentation: 8/3/2019 via email per Paul Hiers

- 103.1 – General (Forms 131-A)

Form-131-A

TRANSMITTAL OF PLANS, SPECIFICATIONS AND ESTIMATES PACKAGE

Date: _____ 30-Day-AD 60-Day-AD
 Proposal/Contract ID: _____ Letting Date: _____ Re Let: No Yes
 Financial Project ID(s): _____
 County: _____ State Road No.: _____
 Federal Funds: No Yes Federal Aid No.: _____
 Total Roadway Length: _____ Total Bridge Length: _____
 Total Project Length: _____ Total Project Length Verified by: _____
 Project Manager Name and Phone Number: _____
 E.O.R. Name, Firm and Phone Number: _____
 Work Mix No.: _____ Work Mix Description: _____

On _____ the District Director of Transportation Development (Production) certified that the Plans, Specifications and Estimates (PS&E) Package is complete, has no known errors or omissions, has been reviewed for constructability and biddability, and is ready to be advertised for construction.

The following items transmitted as noted:

SEALED PLANS SET (____ SHEETS), SPECIFICATIONS PACKAGE (____ PAGES): The Electronic Bid Set was reviewed by _____ and posted to the server on _____.

ESTIMATES OFFICE INFORMATION:

The Authorization Estimate will be reviewed by District Estimates and posted to the server by the PS&E submittal due date. At the time of posting, transfer control of the project files to Central Office.

FEDERAL AID OFFICE INFORMATION:

If Project of Division Interest (PoDI):

Authorized by: _____ Date: _____
Print Name of FHWA Engineer

CONTRACTS OFFICE INFORMATION:

Contract Time: _____ Calendar Days

Select One:

- Standard Acquisition Time: 15 Days
- Other Acquisition Time: _____ Days (Approval required if more than 120 Days)
- Flexible Start Time: _____ Days (Approval required if more than 120 Days)
- Special Start Date: _____ (Approval required for SP0080303B and SP0080303C)

Wage Rate(s): _____

Business Development Initiative Project: No Yes

MSP(s) No Yes

Alternative Contracting: No Yes

(If yes, Type: _____)

Pre Bid Conference Mandatory? No Yes (Date: _____ Time: _____ A.M./P.M.)

(Contact Person and Phone: _____)

(Location of Conference: _____)

SPECIAL NOTES and REQUIREMENTS (List/Explain):

If any items are missing please contact: _____

Contact Name and Phone Number: _____ Section Break (Next Page)

Transmittal of Plans, Specifications and Estimates Package Sheet 2 of 2
REMINDER

1. Check that all components of the Contract Plans are included as listed on the lead key sheet.
2. Check that all sheets are included according to key sheet indices.
3. Check that all sheets have the correct Financial Project ID.
4. Check that all sheets are legible and reproducible.
5. On strung projects, check that all Summary of Pay Item sheets from the Proposal/Contract ID go in the lead project and the Financial Project ID of the strung project is shown on the lead key sheet.
6. Check that bridge pay item sheets show bridge numbers and the quantity breakdowns.
7. E-mail the Transmittal Memo, Contract File Index and attachments to the group "CO-CPKG" and copy the FDOT Project Manager.
8. Verify the accuracy, in the FM system, of the Description, Project Limits, Mileage and Structures. Initial Total Project Length Verification.

Special Notes and Requirements:

- A. Provide the Roadway, Bridge, and Project Lengths in miles, rounded to three decimal places as follows:
 - Total Roadway Length = End Project – Begin Project – Exceptions – Bridges (not including bridge culverts) adjusted for Equations
 - Total Bridge Length = Sum of all End Bridge – Begin Bridge (not including bridge culverts)
 - Total Project Length = Total Roadway Length + Total Bridge Length
- B. Include the Work Mix Number and Work Mix Description corresponding to the information as shown in the Financial Management System on the WP01 Screen
- C. Anything that affects the advertisement, bidding and award that is not listed above such as:
 - a. Railroad Insurance
 - b. Developmental Specifications
 - c. Alternative Contracting items such as Scope Alternates
 - d. Budgetary Ceilings
 - e. Additional Insured Endorsement parties
 - f. For A+B projects, include the User Cost Per Day \$ _____ and Maximum Days _____.
 - g. FGT if both special provisions are needed
 - h. "Push Button"
 - i. Pending permits

- 103.1 – General (Forms 131-B)

Form 131-B

CONTRACT FILE INDEX

Financial Project ID _____ Proposal/Contract ID _____

ATTACHMENTS (check if included or list expected date of transmittal to Central Office)

_____ Calendar Days Recommendation

_____ Preliminary Engineering Certification*

_____ Utility Certification

_____ Status of Environmental Certification

_____ Permit Transmittal Memo**

_____ Railroad Clear Letter

_____ Certificate for Construction (**Form 575-095-05**)

_____ Executed copy of MMOA for Projects with Patterned Pavement

_____ Approval if SP0080701B Computation of Contract Time is used.

_____ Approval for Roundabout Design

_____ Landscape Exception Approval per Engineering and Operations Memorandum 13-1

No Yes Project of Division Interest under agreement dated August 20, 2015*

No Yes Right of Way Certification mailed to State R/W Administrator

No Yes N/A Local Funds Agreement sent to Office of Comptroller

No Yes N/A Local Funds Sent to Office of Comptroller

No Yes N/A Project requires a Maintenance Agreement.

If yes, a Maintenance Agreement (Number _____) was executed on _____

* Include if federally funded.

** Must have District Secretary Approval if Permits are not received by Authorization to Advertise (Federally Funded Projects Only).

Note: _____ If project is federally funded and has a state funded "Goes With", please provide the same documentation as required for a federally funded project.

Name: _____ Date: _____

Print Name of Project Manager/Other Title

REMINDER

PROCESS:

1. Organize attachments in the order listed.
2. Show the number of Maintenance Agreements.
3. Show anticipated date of arrival on any item not included in package.
4. The **Status of Environmental Certification** must be completed on all federally and state funded projects. For federally funded projects, use the Status of Environmental Certification for Federal Project, Form #650-050-13. For state funded only, non-federal eligible (NFE) projects, use the Status of Environmental Certification for State Funded Project, Form #650-050-14. The District Environmental Office must use the StateWide Environmental Project Tracker (SWEPT) to complete the Status of Environmental Certification Form. When a federally funded project is strung with a NFE project, the entire project contract becomes federalized; i.e., both the state funded project and the federally funded project must comply with all applicable federal laws, rules, and regulations related to the federalized contract. In addition, the federally funded project is to be the lead project. Regarding federal environmental compliance under NEPA, the project limits of the approved final environmental document will control the scope of compliance with NEPA requirements. NEPA requirements (including staging areas and Contractors' off-site activities) must only be met for that portion of the project included within the "logical termini" as described in the NEPA document associated with the federally funded portion of the federalized contract.

NOTE: The Contract File Index is an integral part of the Transmittal of Plans, Specifications and Estimates Package.

- 103.1 – General (Forms 131-C)

Form 131-C

REVISION MEMO

DATE: _____
 TO: _____ Final Plans (CO-FINALPLANS)
 FROM: _____, Project Manager
 COPIES: DDE, DCPME
 SUBJECT: Revision Number _____ Letting (mo./yr.) _____
 Financial Project ID _____ (Lead number only)
 Proposal/Contract ID _____
 Federal Funds: No Yes Federal Aid No. _____
 County _____ State Road No. _____

Mandatory Only: No Yes (*If Yes, Signatures Not Required.)

*Concurred by: _____ Date: _____
Signature of Director of Transportation Development or Designee

I have reviewed for effects on the Specifications Package and a package revision is
 is not required. *Approved By: _____ Date: _____
Signature of District Specifications Engineer

If Projects of Division Interest,

*Authorized By: _____ Date: _____
Print Name of FHWA Engineer

**REVISIONS RECEIVED IN THE FINAL PLANS OFFICE WITHIN 15 WORKDAYS
 OF THE LETTING MUST BE APPROVED BY THE DISTRICT SECRETARY.
 NO REVISIONS ALLOWED WITHIN 5 WORKDAYS OF THE LETTING
 WITHOUT APPROVAL.**

*Approved By: _____ Date: _____
Signature of District Secretary

- SUPPLEMENTAL SPECIFICATIONS PACKAGE NUMBER _____ (_____ Pages).
 - REISSUED SPECIFICATIONS PACKAGE _____ (_____ Pages).
 - PLANS REVISION NUMBER _____ (_____ Sheets).
- CONTRACT TIME REVISED: No Yes (If yes, _____ Total Calendar Days)

REMINDER**PROCESS:**

1. Fill out headings.
2. Mandatory Only revisions must not have other revisions included to remain exempt from signature requirement.
3. On Projects of Division Interest, get FHWA concurrence as applicable. Print name of FHWA Engineer and date. *(Not required for Mandatory Only Revisions)*
4. Get concurrence signature from the District Director of Transportation Development or designee. *(Not required for Mandatory Only Revisions)*
5. Get signature of the District Specifications Engineer. *(Not required for Mandatory Only Revisions)*
6. Revisions received in the Final Plans Office within 15 workdays of the letting must be approved by the District Secretary. *(Not required for Mandatory Only Revisions.)* Notify Final Plans. Revisions within five working days of the letting are not allowed without final approval from the Director of the Office of Design. Since there is no assurance that all prospective contractors will get these documents on time to be considered in their bids, approvals for a revision within five working days of the letting will be rare. If the revision is not approved, the project will either be let as is, or be withdrawn from letting. Withdrawing or moving the project to a later letting after advertisement requires approval by the District Secretary and the Chief Engineer.
7. For Supplemental Specification Packages, fill in the Rev. Date, number of pages and a brief description.
8. Enter the sheet number and:
Describe new pay item number, Rev. Date with old quantity and new quantity, deleted pay item number only, or revised quantities; by entering pay item number with old and new quantities.
9. On bridges indicate "each bridge number" with corrected changes.
10. If a revision will impact the utility plans, adjustments or schedules, provide a copy of the revision memo and affected plan sheets to the District Utilities Engineer.
11. Any change to any pay item, requires replacement of the entire Proposal Summary of Pay Items.
12. Email the Revision approval to Final Plans Section (CO-FINALPLANS) to unlock the summary of pay items.
13. Email Revision Memo to Final Plans.

REVISED DOCUMENTS:

1. Revised sealed plans sheets including Summary of Pay Items and Summary of Quantities sheets.
2. Revised District Cost Estimate if federally funded.
3. Revised sealed Supplemental Specifications Package.

- 103.1 – General (Forms 131)

<p data-bbox="1291 258 1461 291">Form 131-D</p> <p data-bbox="576 354 1214 426">Sample Local Agency Maintenance Agreement For Work Performed by the Department</p>
<p data-bbox="1169 468 1453 514">Agency Maintenance Agreement Form 131-D</p>

Commentary on Update: Fully removed Form 132 on 9/2/2020 by Bobby Bull

Date of presentation:

103.1 – Form 132

Form 132

MEMORANDUM

DATE: _____

TO: _____, Federal Aid Programs Manager

FROM: _____, Design Project Manager

COPIES: _____

SUBJECT: **PRELIMINARY ENGINEERING CERTIFICATION** (Federal Aid Projects Only)

Financial Project ID _____

Proposal/Contract ID _____

Federal Aid No. _____

County _____

Project Description _____

Preliminary Engineering (design) was funded with:

- State Funds under
Financial Project ID _____
- Federal Funds authorized under,
Federal Aid No. _____
Financial Project ID _____

The following projects, designed with the same Preliminary Engineering funds, will be strung to (awarded with) the subject project:

Federal Aid No. _____, Financial Project ID _____

Federal Aid No. _____, Financial Project ID _____

The Preliminary Engineering for the subject project is open/ closed. If open,

- it will be closed after PS&E authorization, or
- it is a district wide project. Task order number _____ for this project is closed. The financial number will be open for other projects.
- it will remain open for additional charges, as follows: _____

The FDOT Project Manager may be contacted at (phone): _____

Form 132

REMINDER

Under "Preliminary Engineering (design) was funded with:"

The Financial Project ID should always have a 3X phase in it. 3X is for Preliminary Engineering (design). Example: 415211-1-32-01
or 415211-1-31-01

Preliminary Engineering Certification is required if Federal Funds are used for either Design or Construction phases.

Commentary on Update: Added Layer 3 Switch Worksheet on 8/6/2020 by Darrell Lewis

Date of presentation: 7/31/2020 via email per Alexander Brum

- 103.1 – Layer 3 Switch Worksheet

Form 233-A

LAYER 3 SWITCH WORKSHEET

Chassis Based Switches					
<u>Number of Management Blades</u>					
<u>Backplane Capacity</u>					
<u>Number of Copper Ports</u>					
<u>Protocol Requirements</u>					
<u>Number Fiber Ports #1</u>		<u>Fiber Port Speed</u>			
<u>Number Fiber Ports #2</u>		<u>Fiber Port Speed</u>			
<u>Number Fiber Ports #3</u>		<u>Fiber Port Speed</u>			
<u>Number Power Supplies</u>		<u>Voltage (AC/DC)</u>			
<u>Optics Needed</u>					
	<u>Optic #1</u>	<u>Optic #2</u>	<u>Optic #3</u>	<u>Optic #4</u>	<u>Optic #5</u>
<u># Required</u>					
<u>Speed Requirement</u>					
<u>Distance Required</u>					
<u>Require OEM</u>					

Stack Aggregation Switches					
<u>Number of Fiber Ports</u>					
<u>Number of Copper Ports</u>					
<u>Protocol Requirements</u>					
<u>Number Power Supplies</u>		<u>Voltage (AC/DC)</u>			
<u>Optics Needed</u>					
	<u>Optic #1</u>	<u>Optic #2</u>	<u>Optic #3</u>	<u>Optic #4</u>	<u>Optic #5</u>
<u># Required</u>					
<u>Speed Requirement</u>					
<u>Distance Required</u>					
<u>Require OEM</u>					

Commentary on Update: Added 9/11/2020 to meet the requirement of CFR

Date of presentation: 9/10/2020 DRDE meeting

103.1 – Transportation Management Form (Form 240-A)

<u>Transportation Management Plan (TMP) Form</u>		Form 240-A
Responsible Professional Engineer: _____		
FDOT Project Manager: _____		
State Road: _____		
Project Location: _____		
Roadway ID: _____		
Project Limits (MP): From _____ to _____		
Project Description: _____		

Financial Project ID: _____	New Const.	<input type="checkbox"/>
	RRR	<input type="checkbox"/>
Federal Aid Number: _____		
FHWA Projects of Division Interest Yes <input type="checkbox"/> No <input type="checkbox"/>		
<p><u>In accordance with the requirements of the FDOT Design Manual (FDM) Chapter 240, the following items determine the scope and need of a Transportation Management Plan (TMP). Complete the following checklist and provide brief descriptions of the items included, as appropriate.</u></p>		
<p><u>Indicate if the project meets one or both of the following qualifying conditions as "significant project":</u></p>		
<p><input type="checkbox"/> <u>A project that, alone or in combination with other concurrent projects nearby, is anticipated to cause sustained work zone impacts.</u></p>		
<p><input type="checkbox"/> <u>All Interstate system projects within the boundaries of a designated Transportation Management Area (TMA) that occupy a location for more than three days with either intermittent or continuous lane closures.</u></p>		
<p><u>If either or both above qualifying conditions are met, indicate compliance with the following documents in development of a TMP for the Project:</u></p>		
<input type="checkbox"/> <u>FDOT Design Manual</u>		
<input type="checkbox"/> <u>FDOT Standard Plans</u>		
<input type="checkbox"/> <u>FDOT Standard Specifications for Road and Bridge Construction</u>		
<input type="checkbox"/> <u>FDOT Basis of Estimates Manual</u>		
<input type="checkbox"/> <u>Manual on Uniform Traffic Control Devices for Streets and Highways, (MUTCD), Part VI</u>		
<input type="checkbox"/> <u>Policy on Geometric Design of Highways and Streets, AASHTO</u>		
<input type="checkbox"/> <u>Roadside Design Guide, AASHTO, Chapter 9</u>		
<input type="checkbox"/> <u>FDOT Accessing Transit Handbook, Chapter 4.6.</u>		
<input type="checkbox"/> <u>AASHTO Guide for the Development of Bicycle Facilities, 4th Edition, Chapter 7</u>		

Form 240-A

TMP Components:

Indicate that the following TMP Components have been addressed on the project:

- Temporary Traffic Control Plan (TTCP)**
- Work Zone Speed Established**
 - Speed Reduction Required (Y/N)
 - If Yes, is the "Work Zone Speed less than Existing Posted Speed" documentation completed (Y/N)
- Lane Closure Analysis**
 - If included, was the "Lane Closure Analysis Worksheet" and any restrictions requiring approval completed (Y/N)
- Traffic Pacing**
 - If included, was the "Traffic Pacing Worksheet" completed (Y/N)
- Portable Changeable Message Signs**
 - If included, was the "Portable Changeable Message Sign Worksheet" completed (Y/N)
- Bicycle, Pedestrian, and Transit Accommodations**
- Railroads**
 - Was the District Railroad Coordinator consulted (Y/N)
- Utilities**
 - Was the District Utility Coordinator consulted (Y/N)
- Signals**
 - Was the District Traffic Operations Engineer consulted (Y/N)
- Speed and Law Enforcement Officer**
 - Was the District Construction Office consulted or any usage requiring approval completed (Y/N)

Form 240-A

Transportation Operations Plan (TOP):

Briefly describe TOP components included on the project. If a comprehensive plan has been prepared, indicate below, and attach.

TOP Description:

Public Information Plan (PIP):

Briefly describe PIP components included on the project. If a comprehensive plan has been prepared, indicate below, and attach.

PIP Description:

Commentary on Update: Added "PED", "XING" and "XWALK" to match the change in Chapter 243.

Date of presentation: 7/23/2019 via email per Mary O'Brien

- 103.1 – Standard Abbreviations for Use on PCMS (Form 243-A)

Form 243-A

**STANDARD ABBREVIATIONS FOR USE
ON CHANGEABLE MESSAGE SIGNS**

Standard abbreviations easily understood are:

<u>WORD</u>	<u>ABBREV.</u>	<u>WORD</u>	<u>ABBREV.</u>
Boulevard	BLVD	Normal	NORM
Center	CNTR	Parking	PKING
<u>Crossing</u>	<u>XING</u>	<u>Pedestrian</u>	<u>PED</u>
<u>Crosswalk</u>	<u>XWALK</u>	<u>Road</u>	<u>RD</u>
Emergency	EMER	<u>Service Road</u>	<u>SERV RD</u>
Entrance, Enter	ENT	<u>Shoulder Service</u>	<u>SHLDR SERV</u>
Expressway	EXPWY	<u>Slippery Shoulder</u>	<u>SLIP SHLDR</u>
Freeway	FRWY, FWY	<u>Speed Slippery</u>	<u>SPDSLIP</u>
Highway	HWY	<u>Traffic Speed</u>	<u>TRAF SPD</u>
Information	INFO	<u>Travelers Traffic</u>	<u>TRVLR STRAF</u>
Left	LFT	<u>Warning Travelers</u>	<u>WARN TRVLR</u>
Maintenance	MAINT	<u>Warning</u>	<u>WARN</u>

FDM 110 (Initial Engineering Design Process)

Commentary on Update: Added Commentary on 8/11/2020.

Date of presentation: Via email per Ben Goldsberry on 7/24/2020

- 110.5.8 – Fire Suppression Systems

110.5.8 Fire Suppression Systems

Commentary: *The Department has determined that the details for standpipes, valves and hydrants that have been used on past projects for fire suppression systems located within traffic railings and roadway barriers present significant snag hazards for errant vehicles and thus are not crashworthy. The Department has also determined that there is insufficient justification for incorporating fire suppression systems into, on or attached to traffic railings and roadway barriers in an attempt to improve safety during an extreme event, (e.g. a vehicle fire).*

FDOT owned fire suppression systems are not allowed on bridges, retaining walls or limited access facilities unless they are approved by the Chief Engineer due to special circumstances. Commonly occurring traffic related incidents will not be considered as special circumstances or as justification for the installation of any fire suppression system. If an FDOT fire suppression system is approved, agreements must be executed with a local agency to bear all installation costs, repair costs and maintenance functions.

FDM 111 (Final Engineering Design Process)

Commentary on Update: On 8/26/2020 by Bobby Bull.

Date of presentation:

- 111.1 – General

On projects requiring Federal authorization where the Design Phase and the PD&E Phase overlap, the Department must receive Location Design Concept Acceptance (LDCA), prior to acceptance of the Phase II submittal (prior to advancing into Final Design). To advance past Phase II coordinate with the Environmental Management Office who will work with FHWA (see **Part 1, Chapter 4** of the **PD&E Manual**). The Design Project Manager must coordinate with the PD&E Project Manager, and the District Environmental Management Office to ensure that that the Department has received LDCA for the project. The Design Project Manager will need to convey this information to the district federal aid staff in the District Work Program Office. (**See the Project Management Handbook, Part 2, Chapter 3**). **Figure 111.1.1** shows the major activities included in the final engineering design process.

Commentary on Update: On 8/24/2020 by James McGinnis.

Date of presentation:

- 111.2.1 – Work Program Administration (WPA) System

~~The EOR is responsible for finalizing the project stationing. The District Design Engineer should designate an individual to be responsible for coordinating the input of stationing information into the WPA system.~~

The begin and end stations, and station equations are entered into the WP50 computer screen under FM on the FDOT CL/SUPERSESSSION Main Menu for each WPA location. After logging onto SUPERSESS, the WP50 designees enter on FM (Financial Management System). On the FM Main Menu, press ENTER: 3 for WPA (Work Program Administration). On WPA Main Menu, press ENTER: 25 for WP50 (Station Definition).

Commentary on Update: On 8/24/2020 by James McGinnis.

Date of presentation:

- 111.3.1 – Three-Dimensional Models

~~111.3.1 Three-Dimensional Models~~

~~If horizontally and vertically controlled cross sections are required for plans production to communicate design intent and construct the project, then that section of the project should be three dimensionally (3D) modeled.~~

~~Modification for Non-Conventional Projects:~~

~~Delete **FDM 111.3.1** and see RFP for requirements.~~

Commentary on Update: On 8/24/2020 by James McGinnis.

Date of presentation:

- 111.4 – Standard Specifications and Special Provisions

111.4 Standard Specifications and Special Provisions

The EOR must develop engineering designs that can be constructed, controlled, measured and paid for under the current [Standard Specifications](#).

In the event the work required is not covered by the Standard Specifications or the supplements and special provisions thereto, the EOR must develop Modified Special Provisions or Technical Special Provisions to be made part of the contract for the project.

~~The EOR can obtain Department procedural guidance to assist with the preparation of the specifications package. Additional G~~ guidance on the preparation of Specification packages can be found in the [Specifications Handbook](#).

Commentary on Update: On 9/3/2020 by Bobby Bull.

Date of presentation:

- 111.5 – Standard Specifications and Special Provisions

111.5	Pay Items and Summaries of Quantities
<p>As the engineering plans are prepared, the quantities are calculated, tabulated, and summarized by Pay Item (of work) as stipulated by the Standard Specifications and the Basis of Estimates Manual. The summary of pay items is updated as quantities are determined and summarized. The Estimated Quantities Report (See FDM 902) contains completed quantity summary.</p>	

Commentary on Update: On 8/24/2020 by James McGinnis.

Date of presentation:

- 111.6 – Standard Specifications and Special Provisions

111.6	PS&E Submittal Package
<p>A Plans, Specifications, and Estimates (PS&E) submittal package submittal consisting of the final Plans, Specifications, and Estimates (PS&E), along with any other contract and transmittal documents, is known as a PS&E package. PS&E submittals are numbered consecutively, and re-submittals are required until the project is accepted by the District Program Management Office. The PS&E package is transmitted to the Central Office for letting or is assembled and held in the district for district advertisement and letting. FDM 131 provides further guidance on the contents of the transmittal.</p>	

Commentary on Update: Incorporated by RDB 20-03 on 2/18/2020. Update to Table 111.7.1

Date of presentation: 2/18/2020

- 111.7 – Project Documentation

	Roadway Docs	Transportation Management Plan	TransportationManagementPlan
		Project KMZ	ProjectKMZFile
		ADA	ADA-AssessmentReport
		Roadway	RoadwaySafetyAssessmentReport
		Roadway	RoadwayOperationalAssessmentRe
		Existing	ERCAR
		Community	CommunityAwarenessPlan
		Drainage Map	DrainageMap

FDM 114 (Resurfacing, Restoration and Rehabilitation (RRR))

Commentary on Update: On 6/26/2020 by Mary Jane Hayden.

Date of presentation:

- 114.1 – General

114.1 General

Resurfacing, restoration and rehabilitation (RRR) work is defined as work undertaken to extend the service life of an existing highway and enhance highway safety. This includes the placement of additional surface materials and other work necessary to return an existing roadway to a condition of structural and functional adequacy. This chapter contains processes and requirements necessary to evaluate existing roadways for safety and performance.

This chapter does not apply to projects programmed as Maintenance Resurfacing projects or Ride Only (a.k.a., Ride Rehabilitation) projects.

- 114.1.4 – Pavement Only Projects and Ride Only Projects

114.1.4 → Pavement Only Projects and Ride Only Projects

Pavement Only Projects (POPs) are also known as "Maintenance Resurfacing Projects." They include milling and resurfacing to restore the functional condition of the pavement but are not intended to increase the structural capacity. For POP pavement design requirements for POPs, refer to Chapter 7 of the *Flexible Pavement Design Manual*.

Ride Only Projects are projects those where the existing pavement is in good structural condition but is deficient in ride caused by due to the presence of things like irregularities such as manholes, utility valves, or utility tie-in patches in the wheel path. These projects may entail is may mean either an entire resurfacing of the project limits, or spot resurfacing of damaged areas. The intent of Ride Only Projects is to correct the ride deficiency rating.

This chapter does not apply to projects programmed as POPs or Ride Only Projects other than meeting ADA curb ramp and detectable warning requirements. Work Program Instructions, Chapter 27, states that POP projects cannot be on the "high crash list."

Commentary on Update: On 7/8/2020 per RDB 20-08.

Date of presentation:

- 114.3.2 – Intersections (10)

(10) Addition of signal backplates where it would not require structural modifications to mast arms or span wire systems. See *Traffic Engineering Manual (TEM)*, Section 3.9 for use of flexible backplates where needed.

FDM 115 (Standard Plans and Standard Specifications)

Commentary on Update: On 6/29/2020 by Derwood Sheppard

Date of presentation:

- 115.2.8 – Local Agency Standards and Details

115.2.8 Local Agency Standards and Details

Local agency standards are permitted on off-system projects ~~F~~for items ~~on off-system projects~~ requested by the local maintaining agencies that differ from the Department's **Standard Plans**. Use only local agency standards developed by a Florida Licensed Professional Engineer. Usage of local agency standards requires approval of the District Design Engineer. ~~u~~

Use one of the following methods to incorporate ~~the~~ local agency standards and details into the Contract ~~p~~Plans:

- A. Include as **Modifications to Standards Plans**, as described above.
- B. Add project-specific ~~Place the design~~ details and notes based on ~~from~~ the local agencies "standard" ~~(with or without modification)~~ into the Contract Plans. The engineer responsible for including these details and notes in the Contract Plans becomes the EOR for the application of the entire design. This option should only be used for items completely independent of the Department's **Standard Plans**.
- C. Attach the local agencies "standard(s)" (without modification) ~~for the specific item~~ in the Contract Plans. Only include the standard(s) specific to the project. ~~Include~~ Insert the local agency "standard(s)" into the Contract Plans ~~following this same process as described herein for~~ in accordance with the requirements for **Developmental Standard Plans** provided in **FDM 302**. Reference the agency standards where required using plan notes or callouts.

Consider the need for a Modified Special Provision or Technical ~~Specifically~~ Provision where the local agency standards conflict with, or are not addressed by, the FDOT **Standard Specifications**. Coordinate the need for project-specific pay items with the District Specifications Office. ~~Consider project-specific pay items for items that may affect the Department's cost history for that pay item.~~

FDM 116 (Alternative Intersection and Interchange Review)

Commentary on Update: On 8/31/2020 by Bobby Bull

Date of presentation:

- 116.1 – General

116 ~~Roundabout Evaluation~~ Alternative Intersection and Interchange Review

116.1 General

~~This chapter no longer includes roundabout evaluation information. Roundabout evaluation is~~ Alternative Intersection evaluations are governed by the Intersection Control Evaluation process. See the ***Intersection Control Evaluation (ICE) Manual*** for requirements at the following web address:

https://www.fdot.gov/traffic/TrafficServices/Intersection_Operations.shtm

See ***FDM 301*** for Alternative Intersection and Interchange phase submittal requirements.

Alternative intersections and interchanges provide a fresh approach to addressing congestion and safety concerns on the State Highway System. They are typically more complex than conventional designs and there is little guidance available to designers. For these reasons, all proposed Alternative Intersection and Interchange designs require a detailed review early and throughout the design process.

Configurations subject to this detailed review are listed as follows:

- Roundabout
- Median U-Turn (MUT)
- Restricted Crossing U-Turn (RCUT)
- Jug Handle
- Displaced Left Turn
- Continuous Green-T
- Quadrant Roadway
- Diverging Diamond Interchange (DDI)

Include Alternative Intersection and Interchange Review Packages in the Phase I Submittal. Designate a representative of the State Roadway Design Office as a Lead Reviewer for all phases in ERC.

FDM 117 (Monitor Existing Structures)

Commentary on Update: On 9/4/2020- New Chapter Information brought over from FDM 307

Date of presentation:

- 117 (Entire Chapter Added)

117 Monitor Existing Structures

117.1 General

Monitor Existing Structures includes settlement, vibration, and groundwater monitoring of existing structures during construction as described in **Section 108** of the [Standard Specifications](#). Structures requiring consideration for monitoring typically include buildings, bridges, and retaining walls which are adjacent to construction activities. When there is a concern regarding vibration, structures to be monitored may also include historic features and buildings in which sensitive business operations are conducted; e.g., eye surgery, medical treatments, rehabilitation operations, recording and broadcasting operations, places of worship, antique shops, or museums.

When appropriate, include a note on the General Notes sheet that:

- (1) Restricts hours of construction operations.
- (2) Restricts the type of construction equipment to be used.

Pay item 108-1 is to be used to mitigate the risk for damage occurring to an existing structure due to settlement.

Pay item 108-2 is to be used to mitigate the risk for interfering with the intended use of an existing structure. This pay item is not typically used for residential properties.

Pay item 108-3 is to be used only when recommended by a geotechnical firm and concurred with by the District Geotechnical Engineer. The use of this pay item is not common.

117.2 Inspection and Settlement Monitoring

There are three general types of construction activities of concern:

- Foundations for miscellaneous structures
- Work associated with structures other than miscellaneous structures
- Compaction operations

117.2.1 Miscellaneous Structures

Activities that may cause harm to existing structures include the construction of foundations for mast arm signal poles, strain poles, cantilever signs, overhead truss signs, high mast light poles and ITS.

Based on visual field observations, the EOR will identify existing structures that are recommended to be monitored during these activities. The Department will make the final determination of the existing structures to be monitored. If a determination is made to monitor a structure, include pay item 108-1, and list the structure in the Monitor Existing Structures Excel summary table used to create the Estimated Quantities (EQ) Report.

117.2.2 Structures other than Miscellaneous Structures

Activities that may cause harm to existing structures include the construction of retaining walls, noise walls, sheet pile walls, deep excavations and foundations for bridges and other structures.

- (1) If any existing structure is within the distances specified in **Section 108-2** of the [Standard Specifications](#), include pay item 108-1 and list no structures in the Monitor Existing Structures Excel summary table used to create the EQ Report. Use 250 feet as the limit for pile driving.
- (2) Based on visual field observations, the EOR may recommend monitoring existing structures located beyond the distances specified in **Section 108-2** during these activities. The Department will make the final determination of the existing structures to be monitored. If a determination is made to monitor a structure outside of the specified distances, include pay item 108-1, and list the structure in the Monitor Existing Structures Excel summary table used to create the EQ Report.

117.2.3 Roadway Compaction Operations

Activities that may cause harm to existing structures include embankment and asphalt vibratory compaction.

- (1) If an existing structure is within the distances specified in **Section 108-2** of the [Standard Specifications](#), include pay item 108-1, and list no structures in the Monitor Existing Structures Excel summary table used to create the EQ Report.
- (2) Based on visual field observations, the EOR may recommend monitoring existing structures located beyond the distances specified in **Section 108-2** during these activities. The Department will make the final determination of the existing structures to be monitored. If a determination is made to monitor a structure outside of the specified distances, include pay item 108-1, and list the structure in the Monitor Existing Structures Excel summary table used to create the EQ Report.

117.3 Vibration Monitoring

Activities that may cause harm to existing structures include pile driving, sheet pile and casing installation, and embankment and asphalt vibratory compaction.

Based on visual field observations, the EOR will identify existing structures that are recommended to be monitored during these activities. The Department will make the final determination of the existing structures to be monitored. If a determination is made to monitor a structure, include pay item 108-2, and list the structure in the Monitor Existing Structures Excel summary table used to create the EQ Report.

117.4 Groundwater Monitoring

Based on visual field observations, the EOR will identify existing structures that are recommended to be monitored during anticipated dewatering operations. The Department will make the final determination of the existing structures to be monitored. If a determination is made to monitor a structure, include pay item 108-3, and list the structure in the Monitor Existing Structures Excel summary table used to create the EQ Report.

FDM 120 (Design Submittals)

Commentary on Update: Removed "to the extent practical" on 4/13/2020 by Darrell Lewis

Date of presentation: 4/13/2020 via email per Benjamin Gerrell

- 120.1 - General

120 Design Submittals	
120.1	General
<p>The design process will require various submittals to transfer technical information and decisions between the Engineer of Record (EOR), certain Department personnel, and functional areas. The Department Project Manager is responsible for the adequacy of the submittals or requests and for the coordination of reviews between the Department and the EOR. Each office head including the District Construction and Maintenance Engineers should assume direct responsibility for assigning reviewers and meeting the review schedules. To the extent practical, the contract scope of work should list the information to be furnished by FDOT functional areas and submittals (number and type) required of the EOR. Figure 120.1.1, shown on the following page, is a partial list of functional areas with typical submittals and requests.</p>	

Commentary on Update: Additional Context Request added on 2/18/2020

Date of presentation: 1/15/2020 from DeWayne Carver

- Figure 120.1.1 – List of Requests and Contacts (Sheet 1 of 2)

Figure 120.1.1		List of Requests and Contacts	
		Sheet 1 of 2	
A) Planning		E) Drainage	
Request pavement design (18 Kip ESAL)		Request grade and high water review	
Request project traffic data		Conceptual drainage plan & assumptions	
Request turning movements for intersections		Bridge Hydraulics Report	
Request updates of project traffic data (as needed)		Request drainage design	
<u>Request Context Classification</u>		Request final drainage review	
Railroad contact (Phase I and III)		Permit review	
Plans transmittal letter data (railroad)		SWPPP	
Notification that project is in vicinity of a traffic monitoring site		Erosion Control Plan	

Commentary on Update: Modified text on 4/8/2020 by Darrell Lewis

Date of presentation:

- Figure 120.1 – General

Modification for Non-Conventional Projects:
Delete FDM 120.1 above and replace with the following:
See <u>RFP and FDM 301</u> for a list of submittal requirements.

Commentary on Update: Modified text on 4/1/2020

Date of presentation: 3/23/2020 via email per Maria Overton

- 120.2.2 – Traffic Data

<p>The number of through lanes is usually determined during the project development phase, based on Annual Average Daily Traffic (AADT) and factors included in the typical section. Vehicular traffic data shown on the plans Typical Section sheet includes:</p> <ul style="list-style-type: none"> • <u>AADT for the following:</u> <ul style="list-style-type: none"> ○ eCurrent <u>y</u>Year (refers to when the traffic data is collected), ○ eOpening <u>Y</u>year (as defined in the <u>FDOT Project Traffic Forecasting Handbook</u>), and ○ the dDesign <u>y</u>Year (as defined in the <u>FDOT Project Traffic Forecasting Handbook</u>) • Design hour factor (K is the Department's Standard "K" factor <u>as defined in the <u>FDOT Traffic Forecasting Handbook</u> as provided by the State Transportation Statistics Office</u>),

Commentary on Update: On 8/13/2020 by Bobby Bull.

Date of presentation:

- 120.2.3.3 – Typical Section Sheet

- (4) Traffic Data: provide the following,
 - (a) Current Year and AADT
 - (b) Estimated Opening Year and AADT
 - (c) Estimated Design Year and AADT
 - (d) K, D, T (24-hour) factors.
 - (e) Design ~~Year~~ Hour T factor
 - (f) Design Speed and Posted Speed

FDM 121 (Bridge Project Development)

Commentary on Update: Made edits below on 8/4/2020

Date of presentation: 7/30/2020 via email per Ben Goldsberry

- 121.3.2 – Category 2 Structures

121.3.2 Category 2 Structures

All structure types not listed above are classified as Category 2 Structures unless exempted by the SDO. In addition to, or in lieu of, the criteria listed above, a structure is classified as a Category 2 Structure when any of the following are present:

- (1) Bridge substructures containing any of the following:
 - (a) Post-tensioned components
 - (b) Straddle piers
 - (c) Integral caps
- (2) Bridges designed for vessel collision or bridges with superstructures subject to application of wave loads, ~~coastal bridges that are vulnerable to coastal storms, and bridge water crossings where scour has to be accounted for in the design~~
- (3) Bridges with non-redundant foundations or bridges with micropile foundations
- (4) Any component designed using Fiber Reinforced Polymer (FRP) composite materials except precast elements included in the [Standard Plans](#)
- (5) Braided underpass structures where the beams or flat slab superstructure element is not oriented parallel to traffic of the overlying roadway and a portion of the

Commentary on Update: Made edits below on 8/4/2020

Date of presentation: 7/30/2020 via email per Ben Goldsberry

- 121.8.1 – General

121.8.1 General

The Bridge Analysis is performed during the PD&E phase by qualified bridge engineers. ~~The District Structures Design Engineer must concur with the findings of the bridge analysis, which is part of the preliminary engineering report.~~ The findings of the bridge analysis must be approved by the District Structures Design Office or the State Structures Design Office, as applicable, in accordance with the responsible review authority specified in **FDM 121.5**. The function of the bridge analysis is to determine the general attributes for the recommended bridge. The specific attributes of the bridge will be defined in the BDR.

Commentary on Update: Made edits below on 8/4/2020

Date of presentation: 7/30/2020 via email per Ben Goldsberry

- 121.9.1 – Contents

(5) Foundations: Some foundation types that could be considered are steel and concrete piles, drilled shafts, geosynthetic reinforced soil (GRS) abutments and spread footings. Assess GRS abutments to determine feasibility for all new bridges. If GRS abutments are determined not to be the most suitable alternative for the project, provide a statement in the BDR indicating so and the reasons why (e.g. sinkhole-prone area or differential settlement limit exceeded).

(9) Precast Bridge Options Feasibility Assessment: Investigate the use of either partial or full precast bridge alternate(s) with the specific purpose of accelerating bridge construction and reducing user impacts. As part of this investigation:

Commentary on Update: Made edits below on 8/4/2020

Date of presentation: 7/30/2020 via email per Ben Goldsberry

- 121.10 – Bridge Development Report (BDR) Submittal Checklist

review ~~..The BDR Checklist and~~ consists of the following items:¶¶

- (1) → Typical Sections for Roadway and Bridge:¶¶
The approved typical sections for both the bridge and roadway are required.¶¶
- (2) → Roadway Plans:¶¶
Preliminary roadway plans covering the bridge vicinity are required.¶¶
- (3) → Maintenance of Traffic Requirements:¶¶
Show the number of required lanes and the lane widths of all affected roadways in the Maintenance of Traffic Plan.¶¶
- (4) → Bridge Hydraulics Report and Bridge Hydraulics Recommendation Sheet:¶¶
Prepare the Bridge Hydraulics Report (BHR) and Bridge Hydraulics Recommendation Sheet (BHRS) in accordance with the Drainage Manual. Prepare the Bridge Hydraulics Report (BHR) in accordance with the **Drainage Manual**. Include the Bridge Hydraulic Recommendations Sheet (BHRS) and address the required hydraulic opening, clearances, scour and deck drainage requirements. In addition to design water elevations normally shown, include the Mean High Water (MHW) elevation for tidal crossings and Normal High Water (NHW) for non tidal crossings in the BHRS. Concurrence of the BHR by the District Drainage Engineer with the District Structures Design Engineer for Category 1

¶¶
121-Bridge-Project-Development → ¶¶
¶¶

Topic #625-000-002 → ¶¶
FDOT-Design-Manual → ¶¶
→ ¶¶

Structures and State Structures Design Engineer for Category 2 Structures is required.¶¶

~~(4)~~(5) Geotechnical Report:

Prepare the Bridge Geotechnical Report (Phase I) in accordance with Chapter 3 of the Structures Design Guidelines and the Department's Soils and Foundation Handbook. Document a thorough investigation of all viable foundation types for the bridge and retaining walls. Concurrence of the District Geotechnical Engineer is required for Category 1 Structures and of both the State and District Geotechnical Engineers for Category 2 Structures.

~~(5)~~(6) Bridge Corrosion Environment Report:

Prepare a Bridge Corrosion Report to determine the environmental classifications for the structure in accordance with the Structures Design Guidelines and receive approval from the District Materials Office.

~~(7)~~ Geosynthetic Reinforced Soil (GRS) Feasibility Assessment:

Assess GRS abutments to determine feasibility for all new bridges.

~~(8)~~ Precast Feasibility Assessment:

Investigate the use of either partial or full precast prefabricated bridge alternate(s) with the specific purpose of accelerating bridge construction and reducing user impacts.

~~(6)~~(9) Existing Bridge Plans:

A set of prints of the existing (preferably as-built) bridge plans should be included for replacement structures and widenings. This is of particular importance for widenings and phase construction. These plans are not usually necessary for completely separate alignments or new interchanges unless the existing structures either will be used for new construction activities or will infringe upon the Contractor's allowed work zone.

~~(7)~~(10) Existing Bridge Inspection Report:

A copy of the latest existing Bridge Inspection Report and Structures Inventory and Appraisal Form is required for all widenings and rehabilitations and may be required for new structures. Identify the existing paint system(s) on all significant metal elements of existing structures. Clearly delineate the presence of lead-based paint and asbestos.

~~(11)~~ Existing Bridge Load Rating:

A copy of the latest existing Bridge Load Rating is required for all widenings and rehabilitations.

~~(8)~~ Bridge Hydraulics Report and Bridge Hydraulics Recommendation Sheet:

~~Prepare the Bridge Hydraulics Report (BHR) in accordance with the Drainage Manual. Include the Bridge Hydraulic Recommendations Sheet (BHRS) and address the required hydraulic opening, clearances, scour and deck drainage requirements. In addition to design water elevations normally shown, include the Mean High Water (MHW) elevation for tidal crossings and Normal High Water (NHW) for non-tidal crossings in the BHRS. Concurrence of the BHR by the District Drainage Engineer with the District Structures Design Engineer for Category 1 Structures and State Structures Design Engineer for Category 2 Structures is required.~~

~~(9)~~(12) Wildlife Connectivity:

Describe the decision to include or exclude wildlife connectivity features into the design. The discussion for excluding a wildlife connectivity feature should summarize coordination with the Environmental Management or Permit office (or may be an attached summary memo from one of these offices). The discussion for including wildlife connectivity should refer to the Wildlife Crossing Guidelines, commitments made during PD&E and any other documentation regarding the wildlife connectivity related to the bridge (or may be an attached summary memo from the Environmental Management or Permit office).

~~(10)~~(13) Utility Requirements:

Identify proposed utility attachments to the structure as well as all existing and proposed utilities in the vicinity of the structure. Follow the requirements of the Department's Utility Accommodation Manual regarding attachments to the structure.

~~(11)~~(14) Railroad Requirements:

Identify existing and future railroad requirements. This will include all clearances and crash wall or other construction parameters. Include copies of correspondence with the Railroad Agency.

~~(12)~~(15) Retaining Wall and Bulkhead Requirement:

Identify permanent and temporary retaining wall requirements, and show the proposed type of wall. Also identify the type, location and extent of temporary walls to accommodate phased construction and maintenance of traffic.

For water crossings where erosion and wave action is anticipated, identify the type, location and extent of bulkhead production. Include the proposed tie-back and anchor system in the submittal.

~~(13)~~(16) Lighting Requirements:

Identify proposed lighting on or under the structure.

~~(14)~~(17) ADA Access Requirements:

Identify ADA access requirements that affect the structure.

~~(18)~~ Other:

Commentary on Update: Made edits below on 8/4/2020 and on 9/2/2020 by Gevin McDaniel.

Date of presentation: 7/30/2020 via email per Ben Goldsberry

- 121.11.1 – General

121.11.1 General

Within this phase of work, for both Category 1 and 2 Structures, there are three phases of work; viz., 60% Substructure submittal or 60% Structure Plans, 90% Structure Plans and 100% Structures Plans and Specifications. For projects where preapproved proprietary wall systems cannot be used and fully designed proprietary wall plans are required, submit approved control drawings to the appropriate proprietary wall companies as soon as possible and no later than the 60% substructure submittal. Send a copy of this submission to the DSDO or SDO as appropriate.

At any time during the project development, the reviewer may require submittal of design calculations. All Electronic Review Comments (ERC) shall must be resolved to the Department's satisfaction. ~~After each of the phases, except the 100% Structures Plans Phase, review comments from the Department are sent to the EOR by letter and a marked-up set of prints. The EOR is required to address each of the comments in writing and resolve each comment prior to the next submittal. The Department 100% Structures Plans review comments are to be handled in the same manner; except that unresolved comments may be handled by telephone, in some instances, if confirmed in writing. Also, for any phase, include items and drawings from a preceding phase. Reflect the comments resolved from the previous phase as well as the accumulated design and drafting effort required of the current phase in the drawings.~~

Commentary on Update: Made edits below on 8/4/2020 by Darrell Lewis and on 9/3/2020 by Bobby Bull.

Date of presentation: 7/30/2020 via email per Ben Goldsberry

- 121.12 – Independent Peer Review of Bridges

121.12 Independent Peer Review of Bridges

An Independent Peer Review (IPR) is used to validate the design of structures or portions thereof as defined below. The designated IPR firm will have no involvement with the project other than conducting the IPR and is required to be pre-qualified in accordance with **Rule 14-75 of the Florida Administrative Code.**

- (1) The Department may require an IPR for conventional projects. Consult with the SDO when determining the need for such reviews. Consideration of when to require an IPR include, but is not limited to, the following: the introduction of new complex details or structure types; work being performed that is outside the normal structure type designed by the selected consultant; structures using complex details within standard bridge types (e.g. integral piers, straddle piers, skewed superstructures).
- (2) An IPR is required for Cost Savings Initiatives involving Category 2 Structures. The IPR function must be performed by a single independent engineering firm other than the engineer responsible for the design. The IPR must include:

- → The superstructure and substructure for bridges consisting of Category 2 superstructures.
- → Only the substructure for bridges where the superstructure is Category 1, but the substructure is Category 2.
- → The superstructure and substructure for bridges designed for vessel collision. The IPR must include all spans or continuous units subject to vessel collision.
- → The superstructure and substructure on bridges for which the superstructure is subject to application of wave loads. The IPR must include all spans or continuous units for which the superstructure is subject to application of wave loads.

¶

(3) → An IPR is required for the following structures and components of non-Department-owned projects constructed within, under or over State Road right-of-way, regardless of funding source.

- → Category 1 (excluding miscellaneous structures) or Category 2 Structures.
- → Existing bridge retrofits and modifications regardless of bridge category.
- → Bridge cladding components and attachments.

Modification for Non-Conventional Projects:

Delete the above paragraph and replace with the following:

An Independent Department Review (IDR) is required for all Category 2 Structures. When a firm is designated by the Department to conduct the IDR, the firm will have no other involvement with the project other than conducting the IDR.

¶

An Independent Peer Reviews are (IPR) is used to validate the design of structures or portions thereof as defined below. Consideration of when such reviews should be required include but are not limited to the introduction of new complex details or structure types, work being performed that is outside the normal structure type designed by the selected consultant, when the structure contains complex details within standard bridge types (e.g. integral piers, straddle piers, skewed superstructures).

Independent Peer Reviews are An IPR is required for:

(1) → ~~Cost-Savings-Initiatives-involving-Category-2-Structures. For bridges consisting of Category-1-or-Category-2-substructures-and-Category-2-superstructures, both the substructure and superstructure, require an IPR peer review. Where the superstructure is Category-1, but the substructure component is Category-2, only the substructure component requires an IPR must be peer reviewed. For water crossings designed for subject to vessel collision, the superstructure and substructure for all spans or superstructure units with spans in the waterway require an IPR. For bridges with superstructures subject to application of wave loads, the superstructure and substructure for all spans or superstructure units with spans with wave loads applied to the superstructure in the waterway require an IPR peer review.~~

(2) → ~~The following structures and components of non-Department-owned projects constructed within, under or over State Road right-of-way, regardless of funding source:~~

- ~~• → Category-1 (excluding miscellaneous structures) or Category-2 Structures~~
- ~~• → Existing bridge retrofits and modifications regardless of bridge category~~
- ~~• → Bridge cladding components and attachments~~

~~The Peer-Review IPR must be performed by a single independent engineering firm other than the engineer responsible for the initial work that is designated by the contractor to conduct the review. The designated independent peer review IPR firm will have no involvement with the project other than conducting the peer review IPR and is required to be pre-qualified in accordance with **Rule-14-75-of-the-Florida-Administrative-Code.**~~

~~Modification for Non-Conventional Projects:~~

~~Delete the above paragraph and replace with the following:~~

~~For all Category 2 bridges, an independent peer Department Review (IDR) is required. The Peer Review will be performed by a single independent engineering firm other than the engineer responsible for the initial work and will be designated by the Design-Build Firm or Concessionaire (P3 projects) to conduct the review. When a firm is designated by the Department to conduct the IDR, independent peer review the firm will have no other involvement with the project other than conducting the IDR peer review and is required to be pre-qualified in accordance with **Rule 14-75 of the Florida Administrative Code**. For bridges consisting of Category 1 or Category 2 substructures and Category 2 superstructures, both the substructure and superstructure require an IDR peer review. Where the superstructure is Category 1, but the substructure component is Category 2, only the substructure component requires an IDR has to be peer reviewed. For water crossings designed for with vessel~~

121-Bridge Project Development →

Topic #625-000-002 →
FDOT Design Manual →

~~collision impact, the superstructure and substructure for all spans or superstructure units with spans in the waterway require an IDR. For bridges with superstructures subject to application of wave loads, the superstructure and substructure for all spans or superstructure units with spans with wave loads applied to the superstructure over water require an IDR peer review.~~

The peer review is intended to be a comprehensive, thorough independent verification of the original work. An independent peer review is not simply a check of the EOR's plans and calculations; it is an independent verification of the complete design, including but not limited to an evaluation of all nodal forces, using different programs and independent processes than what was used by the EOR. In addition, all independent peer reviews must include but are not limited to the independent confirmation of the following when applicable:

(7) → Global and local analyses including nodal forces, considering all structural members, connections/nodes and boundary conditions consistent with the structure type.*¶

~~(7)~~(8) → Design results/recommendations (independent verification of the design).*¶

~~(8)~~(9) → Completeness and accuracy of bridge plans.¶

~~(9)~~(10) → Technical Special Provisions, and Modified Special Provisions where necessary.¶

~~(10)~~(11) → Constructability assessment limited to looking at fatal flaws in design approach.¶

* → When Category 2 elements are designed with software using refined analyses (e.g. Grid, Finite Element Method), the peer review consultant is required to verify the design results by a different program/method.¶

Modification for Non-Conventional Projects:α		α
<p>Replace Delete FDM 121.12(2) with the following ¶</p> <p>(2) Final Plan Submittals¶</p> <p>(a) A certification letter following the format presented in Form 121-C (see FDM 103) signed and sealed by the <u>IDR</u> independent review engineer stating that all review comments have been adequately addressed and that the design is in compliance with all Department and FHWA requirements.¶</p>		α
¶	121-Bridge Project Development →	¶
¶		
Topic #625-000-002 →		¶
FDOT Design Manual →		¶
<p>Where substantive changes have been made between the Final Plan Submittal and the “Released for Construction” plans package, the <u>IDR</u> engineer/Independent Peer Reviewer is required to provide an updated Final Certification letter.¶</p> <p>(b) A copy of the Department issued Professional Services Qualification Letter, Part 1, containing the Work Types in which the <u>IDR</u> independent PEER review firm has been qualified to work. The DSDE, for Category 1 bridge projects, or the SSDE, for Category 2 bridge projects, will confirm with the Procurement Office the <u>IDR</u> independent PEER review firm’s prequalification status of the appropriate Work Type.α</p>		α

Commentary on Update: Made edits below on 8/4/2020

Date of presentation: 7/30/2020 via email per Ben Goldsberry

- Table 121.14.3 – Foundation Submittal

<p>Include in all submittals additional details and backup information necessary to substantiate the loading on the foundations. Include a copy of the Geotechnical Report in all submittals. ‡‡ – Widening and projects with phased construction 90% and Final submittals for category 2 bridges require an Independent <u>Department</u>Peer Review.</p>	
--	--

- Table 121.14.3 - Substructure Submittal

90% and Final submittals for category 2 bridges require an Independent <u>Department</u> Peer Review.

- Table 121.14.3 - Substructure Submittal (Continued)

90% and Final submittals for category 2 bridges require an Independent <u>Department</u> Peer Review.

Commentary on Update: Made edits below on 8/4/2020

Date of presentation: 7/30/2020 via email per Ben Goldsberry

- Table 121.14.4 – Substructure Submittal

90% and Final submittals for category 2 bridges require an Independent <u>Department</u> Peer Review.

FDM 122 (Design Exceptions and Design Variations)

Commentary on Update: Change made on 8/20/2020 by Jeremy Fletcher and again on 9/2/2020 by Gevin McDaniel.

Date of presentation: 8/20/2020

- 122.4 – Documentation for Approval

<p>Design Exceptions and Formal Design Variations should include the following documentation:¶</p> <p>(1) → Submittal/Approval Letter (Form 122-A, see FDM 103)¶</p> <p>(2) → Project Description: general project information, location map, context classification, existing roadway characteristics, project limits (mileposts), county section number, work mix, objectives, and obstacles. Include any associated or future limitations that exist as a result of public or legal commitments.¶</p> <p>(3) → Project Schedule and Lifespan: Provide (1) the Plans Production date, and (2) the Letting date for the project. Explain why the proposed Design Exception/Variation is either a temporary or permanent condition. Include any future work planned or programmed to address the condition.¶</p> <p>(4) → Exception/Variation Description:¶</p> <p>(a) → Specific design criteria that will not be met (provide criteria values from both AASHTO and FDOT). Detailed explanation of why the criteria or standard cannot be complied with or is not applicable. Description of the proposed value and why it is appropriate.¶</p> <p>(b) → A plan view, plan sheet, or aerial photo of the Design Exception location, showing the design speed, posted speed, right-of-way lines, and property lines of adjacent property. A photo of the area of the deficiency.¶</p> <p>(c) → Typical section or cross-section of the Design Exception location.¶</p> <p>(d) → The milepost and station location (including left/right side) of the Design Exception.¶</p>	<p>(6) Impacts of the Exception/Variation to:</p> <p>(a) Safety Performance:</p> <p>i. Review and evaluation of the most recent 5 years of crash data from the current date of analysis. Summary of the most recent crash history available within the FDOT State Safety Office CARS (Crash Analysis Reporting System) database, including discussion of any pertinent crash reports. Include a minimum of 3 years of the completely processed 5-year crash data as indicated in Table 122.6.2, history including any pertinent crash reports.</p> <p>ii. Description of the anticipated impact on safety, long and short-term effects. Description of any anticipated cumulative effects.</p>
--	--

Commentary on Update: Removed “to the greatest extent possible” on 4/13/2020

Date of presentation: 4/13/2020 via email per Benjamin Gerrell

- 122.4 – Documentation for Approval

Design Variation Memorandums should include the following documentation, which may be presented in the format of succinct bullets ~~to the greatest extent possible~~:

- (1) Submittal/Approval Letter (**Form 122-A**, see **FDM 103**).

122 – Design Exceptions and Design Variations

Commentary on Update: Changed “certified” language to remain consistent on 2/12/2020. Modified again on 9/2/2020 by Gevin McDaniel.

Date of presentation: 2/3/2020

- 122.4 – Documentation for Approval

- (4) Justification for the proposed criteria.
- (5) ~~Review and evaluation of the most recent 5 years of crash data from the current date of analysis. Review and evaluation of the most recent crash history available within the FDOT CAR System database. Include a minimum of 3 years of the certified completely processed 5 years of crash data as indicated in **Table 122.6.2** history for Central Office approved Design Variations and formal District Design Variations.~~
- (6) Background information which documents or justifies the request.

Commentary on Update: On 8/14/2020 by Bobby Bull.

Date of presentation:

- 122.4 – Documentation for Approval

~~Additional information can be found on the **Crash Location Verification Status Dashboard**.~~

122.5 AASHTO Controlling Elements

Commentary on Update: 5/8/2020 by Gevin McDaniel

Date of presentation:

- 122.5.2.3 – Mitigation

122.5.2.3 Mitigation

Potential mitigation strategies for lane width are:

- (1) Select optimal combination of lane and shoulder widths based on site characteristics to optimize safety and operations by distributing available cross-sectional width
- (2) Signing to provide advanced warning of lane width reduction;
- (3) To improve the ability to stay within the lane:
 - (a) Wide, recessed, or raised pavement markings
 - ~~(b)~~ Delineators
 - ~~(c)~~ Object Markers
 - ~~(b)~~~~(d)~~ Tubular Markers
 - ~~(e)~~~~(e)~~ Lighting
 - ~~(d)~~~~(f)~~ Audible and vibratory treatment, (See **FDM 210.4.6** for arterials and collectors. See **FDM 211.4.4** for LA Facilities.)

Commentary on Update: 5/8/2020 by Gevin McDaniel

Date of presentation:

- 122.5.3.3 – Mitigation

122.5.3.3 Mitigation

Potential mitigation strategies for shoulder width are:

- (1) Select optimal combination of lane and shoulder width based on site characteristics to optimize safety and operations by distributing available cross-sectional width
- (2) Signing to provide advanced warning of lane width reduction
- (3) To improve the ability to stay within the lane:
 - (a) Wide, recessed or raised pavement markings
 - ~~(b)~~ Delineators
 - ~~(c)~~ Object Markers
 - ~~(b)~~ —
 - ~~(e)~~~~(d)~~ Lighting
 - ~~(d)~~~~(e)~~ Audible and vibratory treatment, (See **FDM 210.4.6** for arterials and collectors. See **FDM 211.4.4** for LA Facilities.)

Commentary on Update: 5/8/2020 by Gevin McDaniel

Date of presentation:

- 122.5.4.3 – Mitigation

122.5.4.3 Mitigation

Potential mitigation strategies for horizontal curve radius are:

- (1) To provide advanced warning:
 - (a) Signing
 - (b) Pavement marking messages
 - (c) Dynamic curve warning systems
- (2) To provide delineation:
 - (a) Chevrons
 - ~~(b)~~ Post-mounted dDelineators
 - ~~(b)~~~~(c)~~ Tubular Markers
 - ~~(e)~~~~(d)~~ Reflectors on barrier

Commentary on Update: 5/8/2020 by Gevin McDaniel

Date of presentation:

- 122.5.5.3 – Mitigation

122.5.5.3 Mitigation

Potential mitigation strategies for superelevation rate exceptions are:

- (1) To provide advanced warning:
 - (a) Signing
 - (b) Pavement marking messages
 - (c) Dynamic curve warning systems
- (2) To provide delineation:
 - (a) Chevrons
 - ~~(b)~~ Post-mounted dDelineators
 - ~~(b)~~~~(c)~~ Tubular Markers
 - ~~(e)~~~~(d)~~ Retroreflective strips on face of barrier

Commentary on Update: 5/8/2020 by Gevin McDaniel

Date of presentation:

- 122.5.7.3 – Mitigation

122.5.7.3 Mitigation

Potential mitigation strategies for maximum grade are:

- (1) Signing to provide advanced warning
- (2) To improve ability to stay within the lane:
 - (a) Enhanced pavement markings
 - (b) Delineators
 - (b)(c) Tubular Markers
 - (e)(d) Audible and vibratory treatment, (See **FDM 210.4.6** for arterials and collectors. See **FDM 211.4.4** for LA Facilities.)

Commentary on Update: Updated values and notes on 7/31/2020

Date of presentation: 7/15/2020 via email per Benjamin Jacobs

- Table 122.6.1 – FDOT Average Crash Costs by Facility Type

Table 122.6.1 FDOT Average Crash Costs by Facility Type

Type Facility	Divided Roadway			Undivided Roadway		
	Urban	Suburban	Rural	Urban	Suburban	Rural
2-3 Lanes	\$107,732	\$201,527	\$355,183	\$124,618	\$267,397	\$523,727
4-5 Lanes	\$123,406	\$225,315	\$473,637	\$112,896	\$190,276	n/a
6+ Lanes	\$123,598	\$166,258	\$451,492	\$41,650	n/a	n/a
Interstate	\$153,130	n/a	\$327,385	n/a	n/a	n/a
Turnpike	\$1238,253 762	n/a	\$25569,66 2205	n/a	n/a	n/a

Notes:

- (1) Average Cost/Crash: **\$159,093**
- (2) The above values were derived from 2013² through 2017⁶ traffic crash and injury severity data for crashes on state roads in Florida using the formulation described in *FHWA Technical Advisory "Motor Vehicle Accident Costs", T-7570.2, dated October 31, 1994.* Base costs derived and from a memorandum from USDOT: "Revised Departmental Guidance on Treatment of the Economic Value of a Statistical Life (VSL) in the U.S. Department of Transportation Analyses", dated August 8, 2016 updating the value of life saved from \$9.4 million to \$9.6 million for 2015 data with a growth factor applied to increase the base cost to \$9.7 million in the current analyses. Costs are computed for the actively state-maintained State Highway System (SHS) only.

Commentary on Update: Updated values and notes on 7/31/2020

Date of presentation: 7/15/2020 via email per Benjamin Jacobs

- Table 122.6.2 – FDOT KABCO Crash Costs

Crash Severity	Comprehensive Crash Cost
Fatal (K)	\$10,670,000
Severe Injury (A)	\$872,612
Moderate Injury (B)	\$174,018
Minor Injury (C)	\$106,215
Property Damage Only (O)	\$7,700
Note: (1) (1) Source: Florida Department of Transportation State Safety Office's Crash Analysis Reporting —(CAR) System, analysis years 2013 2 through 2017 6 . <u>Published by FDOT State Safety Office on 12/20/2019.</u>	

Commentary on Update: Updated values and notes on 7/31/2020

Date of presentation: 7/15/2020 via email per Benjamin Jacobs

- Table 122.6.4 – HSM Crash Distribution for Florida

Table 122.6.4 HSM Crash Distribution for Florida							
Type Facility		Abbreviation	K	A	B	C	O
Rural Roadways	2-lane Undivided	R2U	0.028	0.094	0.181	0.187	0.509
	4-lane Undivided	R4U	0.033	0.093	0.164	0.186	0.524
	4-lane Divided	R4D	0.028	0.090	0.187	0.196	0.499
Urban & Suburban Arterials	2-lane Undivided	U2U	0.009	0.050	0.150	0.224	0.567
	3-lane TWLTL	U32LT	N/A				
	4-lane Undivided	U4U	0.004	0.031	0.110	0.204	0.650
	4-lane Divided	U4D	0.008	0.046	0.142	0.234	0.571
	5-lane TWLTL	U52LT	N/A				
Freeways	Rural		0.017	0.065	0.143	0.163	0.612
	Urban		0.006	0.035	0.113	0.206	0.641
	Ramps		0.004	0.032	0.107	0.210	0.647
All	All Roadways and Ramps		0.007	0.041	0.124	0.217	0.611
Notes:			A - Incapacitating Injury		C - Possible (or minor) Injury		
K – Fatality			B - Non-incapacitating Injury		O - Property Damage Only		
<p><u>Data Source: Florida Department of Transportation, State Safety Office's Crash Analysis Reporting (CAR) database, analysis years 2013 through 2017. Publishing by FDOT State Safety Office on 12/20/2019.</u></p>							

FDM 123 (Engineering Design Estimate Process)

Commentary on Update: On 9/4/2020 by Bobby Bull.

Date of presentation:

- 123.1 - General

<p>Modification for Non-Conventional Projects:</p>
<p>Delete FDM 123.1 and replace with the following:</p>
<p>123.1 General</p>
<p>The construction cost estimate (Authorization Estimate) is one of the last activities performed on design projects prior to beginning the procurement process. Use the following items to develop a construction cost estimate:</p>
<p>(1) The Concept Plans including a summary of quantities Estimated Quantities Report, if <u>available</u>;</p>
<p>(2) The Request for Proposal.</p>

Commentary on Update: On 9/4/2020 by Bobby Bull.

Date of presentation:

- 123.4.1 - Summary of Quantities

<p>123.4.1 Summary of Quantities</p>
<p>All quantities for pay items are tabulated and totaled on Summary of Quantity sheets in the plans. The summary boxes should be organized in pay item sequence for the project. See FDM 902 for information on compiling and reporting quantities. See the Basis of Estimates Manual for further details. Place detailed documentation on calculations in the project's Calculations folder and included in the CADD_[FPID].ZIP file with the Final Plans Submittal. See the CADD Manual for details. Summary of Quantity sheets in the plans should be completed in accordance with FDM 307.</p>

Commentary on Update: On 9/4/2020 by Bobby Bull.

Date of presentation:

- 123.4.2 - Breakdown of Quantities

123.4.2 Breakdown of Quantities

Pay item quantities are loaded into the Designer Interface system by category, to reflect the work shown in each design group. When incidental work from one design group is included in the component plans for another group, the pay items must continue to be loaded in the appropriate category for the work to be completed. When a contract contains more than one Financial Project ID, pay item quantities for each project are loaded separately. ~~the plan summary boxes for each project should clearly distinguish the location for each item of work. Similarly, the plan tabulation sheets~~ **Estimated Quantities Report** must show separate quantities for each project. Only the Summary of Pay Items run from the **AASHTOWare Project™ Department's WebGate Reporting menu (formerly Transport reports menu)** will show the project totals, as well as the combined proposal/contract total. Additional information is available in **Chapter 9** of the **Basis of Estimates Manual**.

Commentary on Update: On 9/4/2020 by Bobby Bull.

Date of presentation:

- 123.4.3 – Participating and Non-participating Pay Items

123.4.3 Participating and Non-participating Pay Items

~~When multiple funding sources are available for a single project (federal, state, or local funds), an additional breakdown of pay item quantities may be necessary to identify those pay items or quantities that will “participate” in the available funding. For projects with federal funds, most of the pay items are eligible to “participate” for federal funds. Federal funds are not eligible for use on routine maintenance activities; e.g., mowing, litter removal, but may be used for preventative maintenance (i.e., extending the useful life of a highway.)~~

~~Refer to **Chapter 9** of the **Basis of Estimates Manual** for more information on loading pay items with multiple funding sources. Note that with multiple funding sources, the method of presenting this information in the plans must be of sufficient detail for project personnel to readily distinguish between participating and nonparticipating work, including its physical location on the project. Project personnel must be able to properly account for the necessary separation of quantities.~~

~~For Lump Sum or projects without federal funds, most items will “participate” in the available funding source(s). Unless otherwise directed by the Federal Aid or Work Program Office, all items of work (not including the initial contingency item) will default to participate in the available funding source.~~

Commentary on Update: On 9/4/2020 by Paul Hiers.

Date of presentation:

- 123.4.4 – Utility Work by Highway Contractor Agreement Plans

123.4.4 Utility Work by Highway Contractor Agreement Plans

~~When separate plans for utility construction are to be included in the contract, special attention should be given to establishment of pay items and loading the projects into Designer Interface. Refer to the Work Program Instructions, Section 42 for guidance on the Financial Project ID phase number identification.~~

~~For contracts with more than one project, the pay items for Mobilization and Maintenance of Traffic will be shown on each project's Summary of Pay Items. An exception to this is when the contract contains a Utility Work by Highway Contractor (UWHC) Agreement. The pay items for Mobilization and Maintenance of Traffic will not be shown on the Summary of Pay Items for the UWHC Agreement. The cost of these items will be included in the lead project.~~

Commentary on Update: On 9/4/2020 by Paul Hiers

Date of presentation:

- 123.4.5 – Pay Item Notes

123.4.5 Pay Item Notes

~~Pay item notes are to be used to clarify basis of quantity, work included or method for payment. Pay item notes should not restate the Standard Specifications or Standard Plans. This will help to avoid discrepancy of documents. Refer to FDM 307 for details on the usage of pay item notes in the plans.~~

~~Modification for Non-Conventional Projects:~~

~~Delete FDM 123.4.~~

FDM 124 (Project Quality Control Plan)

Commentary on Update: Incorporated by RDB 20-05, Revision on 7/28/2020 by Ben Goldsberry

Date of presentation:

- 124 - General

124.1 General

Quality Assurance (QA) and Quality Control (QC) are two processes used to ensure that deliverables are complete, orderly, correct, and appropriate for the intended purposes. The quality of the deliverable must meet or exceed industry standards; i.e., "Due Diligence" ("Due or Ordinary Care").

Quality Control (QC) is the process of checking, reviewing, and revising deliverables to comply with Department requirements. Quality Assurance (QA) is enforcing and verifying that quality control procedures have been established and performed.

This chapter describes the Department's QA/QC Management Plan for the development of deliverables. A deliverable is any professional service document (e.g., Plans, Specifications, Reports) that is produced for the Department.

Modification for Non-Conventional Projects:
Delete FDM 124.1 and insert the following:
124.1 General
See the RFP for Quality Management Plan (QMP) requirements which describes the Quality Control (QC) procedures to be utilized to verify, independently check, and review all design drawings, specifications, and other contract documents. The QMP must establish a Quality Assurance (QA) program to confirm that the Quality Control procedures are followed. In addition to the QMP all Category 2 Bridge Designs must be verified by an Independent Peer Review. See RFP for requirements.
The Department reserves the right to conduct an audit of the Design Build Firm's QMP process to ensure the submitted plan for the project is being properly executed. Similarly, the Department reserves the right to conduct an audit of the Independent Peer Review to ensure that independent verification of the design and plans is being properly executed. All documentation for QA/QC and independent peer review (e.g., check prints, design calculations) must be kept on file until construction of the project is complete at a minimum.

FDM 125 (Quality Assurance Reviews)

- *Commentary on Update: Incorporated by RDB 20-05*

FDM 126 (Lane Repurposing Projects)

Commentary on Update: On 6/2/2020 by Systems Implementation

Date of presentation:

- 126 – (Entire Chapter)

126 Lane ~~Elimination~~ Repurposing Projects

Modification for Non-Conventional Projects:

Delete **FDM 126**.

126.1 ~~General~~

Lane ~~elimination~~ repurposing projects (a.k.a., “road diets”, “~~lane repurposing~~elimination”, or “lane reductions”) are intended to reduce the number of travel lanes ~~and effective width of the road~~ to achieve systemic improvements. Generally, the purpose of these projects is to reconfigure the existing cross section to ~~allow enhance~~ other uses ~~and of and~~ travel modes. Lane ~~elimination~~ repurposing projects typically ~~provide more livable environments and~~ contribute to ~~the~~ economic development, ~~livability~~ and vitality ~~of to~~ a community. The recovered travel ~~way laneway~~ can be used to accommodate ~~other uses such as separated or buffered other modes of travel purposes uses, such as~~ bicycle lanes, wider sidewalks, landscaping, on-street parking, bulb-outs, traffic calming, ~~transit, and and~~ pedestrian refuge islands. ~~Guidance on the development and review processes for repurposing lanes on the SHS is provided in the Department’s FDOT Lane Repurposing Guidebook.~~

A local government entity (e.g., municipality, county, ~~Metropolitan Planning Organization (MPO), MPO, Transportation Planning Organization (TPO)~~) or the Department can submit a request for the ~~elimination~~ repurposing of travel lanes on the State Highway System (SHS). A private entity may only submit a request through a local government entity. ~~Proposed lane repurposing projects may be part of a larger community vision. vision and must have local government support.~~ With sufficient advanced planning, lane repurposing projects are often done in conjunction with a ~~Resurfacing, Restoration and Rehabilitation (RRR)~~ projects. It is preferred that lane repurposing projects be identified ahead of time through a planning exercise such as a ~~district area wide bicycle pedestrian multimodal mobility plan, community vision plan, or downtown redevelopment plan.~~

If the project has a PD&E phase, the requirements of this chapter are followed during the PD&E study prior to the selection of a preferred alternative. See **Part 1, Chapter 2** of the [PD&E Manual](#) for additional information.

126 Lane ~~Elimination~~ Repurposing Projects

126.2 Requirements

Four-lane undivided roadways with AADT \leq 20,000 are typically good candidates for a lane repurposing (e.g., converting to a two-lane, two-way road with a center-left-turn lane). However, projects are evaluated for lane repurposing feasibility on a case-by-case basis.

Lane repurposing projects must comply with AASHTO and Department design criteria. A Design Exception or Design Variation is required when an existing or proposed design element does not comply with the governing criteria. See **FDM 122** for information on Design Exceptions and Design Variations.

Lane repurposing projects should be consistent with the Long-Range Transportation Plans (LRTP), Transportation Improvement Program (TIP), and Transit Development Plan (TDP).

Analyze impacts of a lane repurposing project with consideration for the following: Such areas to consider may have in different areas, such as:

- Utilities
- Access management
- Businesses
- Traffic operations and Landscaping (context classification)
- Safety
- Emergency responders
- Functional classification
- Context classification

Traffic impacts to parallel routes

- Pedestrian and bicyclist activities
- Transit and freight routes
- Environmental impacts
- Evacuation routes
- shade or (architectural) or landscape
- Speed (target, design and posted)
- Traffic impact due to diversion to parallel routes

Four-lane undivided roadways with AADT \leq 20,000 are typically good candidates for a lane repurposing (e.g., converting to a two-lane, two-way road with a center-left-turn lane). However, projects are evaluated for lane repurposing feasibility on a case-by-case basis.

If exclusive bus lanes/business access & transit (BAT) lanes are proposed in the lane repurposing project, then additional coordination with Office of Modal Development/Public Transit and local transit agency will be needed.

Since a lane elimination/repurposing projects may redistribute traffic to other transportation facilities, so impacts to those corridors must also be evaluated. In addition to impacts of lane repurposing projects, cConduct public involvement activities in accordance with the [Public Involvement Handbook](#).

Guidance on the development and review processes for eliminating repurposing lanes on the SHS is provided in the Department's [Statewide Lane Elimination/Repurposing Elimination Guidance \(Phase 1 and Phase 2\)](#).

126.2.1 Federal-Aid Projects

Follow the National Environmental Policy Act (NEPA) for lane elimination/repurposing projects that use federal funding.

126.2.2 Roadway **Functional** Reclassification

A lane elimination/repurposing project can potentially change the functional classification of a roadway, which could affect planning, funding eligibility, traffic analyses, project prioritization, and state and federal reporting requirements.

A request for a change in functional classification requires review and approval by the Department and FHWA. Approval is typically requested during the preliminary review process, as detailed in [FDM 126.3](#). More information is provided in the Department's [Urban Boundary and Functional Classification Handbook](#). This handbook can be found at the FDOT Transportation Data and Analytics website: <https://www.fdot.gov/statistics/tsopubs.shtm>.

A proposed change in functional classification of a roadway on the National Highway System (NHS) requires coordination between the Department, local officials, and FHWA.

126.3 Application Process

The application process consists of three main steps: coordination between Applicant and the District, a preliminary review and approval by District, and the final review and

approval by Central Office (CO). **FDM chapter 103** includes the **Forms 126-A, B, and C** that are utilized during this process. **Form 126-A** is used as guidance for project meetings, and reports and methodology. **Form 126-B** establishes the initial notification to CO Systems Implementation Office (SIO) and **Form 126-C** confirms the final review and approval from CO.

There are three steps in the application process:

- Applicant contacts District Lane Elimination Repurposing Coordinator
- Preliminary Review by District
- Final Review and Approval by District and Central Office

126.3.1 **Applicant Project Initiation — Contacts — District — Lane Elimination Repurposing Coordinator**

- (1) The applicant submits the lane elimination repurposing request to the District Lane Elimination Repurposing Coordinator.
- (2) The applicant must consult with the applicable District to determine the specific analysis requirements and review process that applies to their request. The applicant submits required information in the Initial Meeting and Methodology Checklist (**Form 126-A**) to the district prior to the initial meeting.
- (3) The District Lane Repurposing Coordinator schedules the initial meeting to discuss the proposed lane repurposing project with the District Review Team, which includes the following district offices:
 - (a) Planning
 - (b) Environmental Management
 - (c) Modal Development
 - (d) Design
 - (e) Traffic Operations
- (4) The applicant attends this initial meeting to discuss the process and requirements of the lane repurposing request. The applicant completes and submits the Initial Meeting and Methodology Checklist (see **FDM 103, Form 126-A**.)
- (5) The District Lane Repurposing Coordinator submits the initial notification to Central Office Systems Implementation Office. This will include:
 - (a) Initial Meeting and Methodology Checklist (**Form 126-A**)

(b) Meeting Minutes

(c) The applicant completes and submits the Initial Meeting and Methodology Checklist (see **FDM 103, Form 126-A.**) Initial Notice to Central Office (**Form 126-B**), with concurrence from the District Planning and Environmental Administrator, District Design Engineer and District Traffic Operations Engineer.

126.3.2 District 126.3.2 — Preliminary Review

The District Preliminary Review is as follows:

(1) The District Lane Elimination Repurposing Coordinator schedules Coordinator schedules the initial meeting to discuss the proposed lane elimination repurposing project with the District Review Team, which includes the following offices:

(2) Planning

(3) Environmental Management

(4) Modal Development

(5) Design

(6) Traffic Operations

(7) The applicant attends this initial meeting to discuss the process and requirements of the lane elimination repurposing request. The District Lane Elimination Repurposing Coordinator submits the initial notification to Central Office Systems Implementation Office. This will include:

(8) Initial Checklist (Form 126-A)

(9) Methodology Checklist (Form 126-B)

(10) Meeting Minutes

Initial Notice to Central Office (Form 126-C), with concurrence from the District Design Engineer and District Traffic Operations Engineer.

(1) The applicant will submit a draft concept report containing a proposed typical section to the District Lane Repurposing Coordinator for review.

(2) The District Lane Repurposing Coordinator will coordinate the review of the project and concept report with the District Review Team.

After District reviewer's acceptance, a Final Concept Report must be submitted along with Form 126 C and signed at the District level to Central Office for review. The District Lane Elimination Repurposing Coordinator will work closely with Central Office staff during this review phase, especially if the application is challenging or controversial.

126.3.3 Final Review and Approval

The Final Review and Approval process is as follows:

- (1) The District Lane Elimination Repurposing Coordinator submits the Final Review and Approval Notice to Central Office Systems Implementation Office (**FDM 103, Form 126-DC**), signed by the District Planning and Environmental Administrator, the District Design Engineer, and the District Traffic Operations Engineer, to the Central Office Systems Implementation Office, along with the Final Concept Report.
- (2) The Systems Implementation Office coordinates the review of the lane elimination repurposing request with the different offices in Central Office (e.g., Design, Traffic Engineering and Operations) and obtains concurrence from the Chief Planner.
- (3) The Systems Implementation Office submits the lane elimination repurposing request for obtaining the final approval or denial to the Chief Engineer. The Chief Engineer has the final authority to approve, deny or object (with comments) to the lane elimination repurposing request.
- (4) The Systems Implementation Office submits notification to the District Lane Elimination Repurposing Coordinator of the Chief Engineer's decision.
 - (a) Approved: application process is complete.
 - (b) Denied lane elimination repurposing request: includes an explanation for the denial.
 - (c) Objection with comments: the applicant may resubmit the lane elimination repurposing proposal to the District, once District once the comments have been addressed. The resubmittal must include an updated and signed **Form 126-D—C** (included in **FDM 103**).

FDM 130 (Signing and Sealing Documents)

Commentary on Update: On 6/18/2020 by Paul Hiers.

Date of presentation:

- 130.2.1 – Digital Signing and Sealing

130.2.1 Digital Signing and Sealing

Digital Delivery is the standard method of electronically transmitting contract documents to the Department. This includes the creation of Portable Document Format (PDF) files of contract plans and specifications, which are signed and sealed with a Digital Signature. The [*CADD Manual*](#) defines the type of digital certificate to be used for Digital Signature. A representation of the professional's seal next to the Digital Signature Appearance is required for Contract Plans.

Place the following **OFFICIAL RECORD** note ~~along the right edge of~~ on each plan sheets that ~~are~~ is digitally signed and sealed:

“THE OFFICIAL RECORD OF THIS SHEET IS THE ELECTRONIC FILE DIGITALLY SIGNED AND SEALED UNDER RULE 61G15-23.004, F.A.C.”

For standard size (11"x17") plan sheets, the OFFICIAL RECORD note appears along the right edge of the plan sheet just outside the border. For large format (36"x48" or 36"x72") plan sheets, the OFFICIAL RECORD note appears in the information block located in the bottom right portion of the sheet.

Commentary on Update: Clarified the language to remove the misinterpretation that early works components only apply to roadway plans.

Date of presentation:

- 130.2.1 – Digital Signing and Sealing

Topic #625-000-002
FDOT Design Manual

Electronically transmit the Contract Plans as individual signed and sealed PDFs of component plans. The list of component plans for Digital Delivery is comprised of the following:

- (1) Roadway Plans
- (2) Signing and Pavement Marking Plans
- (3) Signalization Plans
- (4) Intelligent Transportation System (ITS) Plans
- (5) Lighting Plans
- (6) Landscape Plans
- (7) Architectural Plans
- (8) Structures Plans
- (9) Toll Facilities Plans

The cComponent plans listed above may require insertion of sheets that were prepared early in, or prior to the design process (“early works”). The following early plan sheets may be contained in a separate signed and sealed PDF that is to be included as part of the Contract Plans:

GR-# Soil Survey and Report of Core Borings
TR-# Tree Survey
UTV-# Verified Utility Locate

No other plans sheets than those listed above are to be submitted separate from the component plans, except for manually signed and sealed documents as discussed in **FDM 130.2.2**.

Commentary on Update: Changed reference from FDM 131 to FDM 132.

Date of presentation: Changed on 7/21/2020 via email per Anna Harlson.

- 130.4.1 – Contract Plans Set

130.4.1 Contract Plans Set

Prepare design revisions as outlined in **FDM 132**. Sign and seal the revision package PDF in accordance with **FDM 130.2**.

Prepare post-let revisions as outlined in **FDM 132** and **Chapter 5** of the **Construction Project Administration Manual (CPAM)**. Sign and seal the revision package PDF in accordance with **FDM 130.2**.

FDM 131 (Plans Processing)

Commentary on Update: Made edits below on 8/5/2020 by Darrell Lewis and again on 8/24/2020 by James McGinnis.

Date of presentation: 7/28/2020 via email per Jodi Jarrell

- 131.1 – General

131.1 General

This ~~chapter~~~~section~~ describes the critical activities required to process the contract plans, specifications and estimate for letting. It identifies the transmittal forms, certifications and other documents prepared by the District and the various offices involved in processing a Plans, Specifications & Estimates (PS&E) submittal package.

This chapter also outlines the ~~revision process, and the~~ steps to resubmit a project that has been withdrawn from letting.

Projects must be electronically delivered in Digital Delivery format in accordance with **FDM 130** and the **CADD Manual**. ~~The latest information regarding the letting of electronic plans and specifications (including critical dates) will be posted on the **Final Plans Web Page** as new information becomes available.~~

Commentary on Update: On 8/24/2020 by Paul Hiers.

Date of presentation:

- 131.1.1 – Definitions

(2) **Final Plans:** ~~Plans include 2D Contract Plans Set(s) and 3D Build Information Model (BIM) files. Plans show the location, character, dimensions, and details of the work. Plans are considered final after changes noted during the Phase IV submittal review are completed and verified.~~

(2)(3) **Final Plans:** Plans are considered final after changes noted during the Phase IV submittal review are completed and verified.

(3)(4) **Mandatory Specification Revision:** A required change to the Specifications, Design Standards, or other contract documents, caused by changes in Federal Regulations, State Statutes, Rules, safety improvements, technological changes,

(5) → **Plans, Specifications, and Estimates (PS&E) Submittal Package:** This package is ~~transmitted~~ **delivered** by the District Final Plans Office to ~~State Program Management Office, Final Plans section, Central Office Final Plans~~ or to District Contracts ~~Office~~ for letting. The package consists of signed and sealed Final Plans and ~~BIM.zip~~, Specification Package, the ~~Estimated Quantities Report Authorization Estimate~~, and other contract and transmittal documents. PS&E Submittals are numbered ~~consecutively~~ and re-submittals are required until the project is accepted by the District Program Management Office. ¶

(4)(6) → **Authorization Estimate:** ~~The Official Estimate for construction of the project is kept secure within the Design Quantities and Estimates (DQE) application and only authorized personnel have access to it. The Authorization Estimate is a report generated by DQE that is automatically saved to a server for access by authorized users. The Authorization Estimate must be posted to the server no later than the PS&E Transmittal Date.~~ ¶

(5)(7) → **Production Date:** The committed completion date for Final Plans and certifications (e.g., utilities, permits, R/W, environmental); these documents must be ready for compilation into the Contract File Index. ¶

(6)(8) → **PS&E Phase:** The plans processing period between Phase IV plans and delivery of PS&E Package to ~~State Program Management Office, Final Plans section, Central Office Final Plans~~ or to District Contracts ~~Office~~. ¶

(7)(9) → **PS&E Review(s):** Review(s) consisting of the Final Plans, Specifications and Estimate along with any other contract and transmittal documents. ¶

(8)(10) → **PS&E Transmittal Date:** The committed date for the ~~transmittal~~ **delivery** of the PS&E Submittal Package to ~~State Program Management Office, Final Plans section, Central Office Final Plans~~ or to District Contracts ~~Office~~. ¶

(9)(11) → **Supplemental Specifications Package:** A signed and sealed document modifying the Specifications Package after it has been accepted by ~~State Program Management Office, Final Plans section, Central Office Final Plans section~~ or District Contracts ~~Office~~. ¶

Commentary on Update: On 8/24/2020 by Paul Hiers.

Date of presentation:

- 131.2 – District Plans Processing

<p>131.2 District Plans Processing</p> <p>There are plans processing activities that occur in the Districts prior to submitting the PS&E Submittal Package to State Program Management Office, Final Plans section, Central Office Final Plans or to District Contracts Office. The schedule for these activities vary by District; contact the District Final Plans Office for specific requirements.</p>
<p>Review of contract documents during the PS&E Phase often require modifications to the plans, specifications or quantities. Modifications made prior to the District Estimates Office changing the Estimated Quantities Report Project Preconstruction (PrP) Workflow/Phase input or Central Office acceptance of the PS&E Submittal Package are Plan Changes. ¶</p>
<p>Plan Changes include modifications, deletions, or addition of data on individual sheets, or adding and deleting entire sheets. Plan Changes also include modifications, deletions, or addition of data to 3D Build Information Model (BIM) files. Plan Changes are not Plan Revisions (as described FDM 132); therefore, do not note Plan Changes in the Revision Block on the sheets.</p>

Commentary on Update: On 8/24/2020 by Paul Hiers.

Date of presentation:

- 131.2.1 – Authorization Estimate

<p>131.2.1 → Authorization Estimate ¶</p> <p>The Authorization Estimate (official construction cost estimate used for budgeting construction dollars in the Work Program) is one of the last activities performed during the design phase. Using the final quantities loaded into AASHTOWare Project Preconstruction™ by the EOR, District Estimates Office will adjust unit prices (when appropriate). Consider the following when adjusting unit costs The District Estimator typically considers the following items when adjusting costs: ¶</p> <ul style="list-style-type: none"> • → Order of magnitude of the quantity (exceeding high or low) ¶ • → Availability of materials ¶ • → Accessibility to project location ¶ • → Complexity of work, or Traffic Control Plan ¶ • → Specialty work or materials ¶ • → Contract time restrictions ¶ <p>When finalized, post the Authorization Estimate to the server. Posting must be no later than PS&E Transmittal Date. ¶</p>
--

Commentary on Update: On 8/24/2020 by Paul Hiers.

Date of presentation:

- 131.2.2 – Processing the PS&E Submittal Package

131.2.2.1 Processing the PS&E Submittal Package to Tallahassee

District Final Plans Office initiates the collection and processing of PS&E Submittal documents using the PS&E Module within Project Suite Enterprise Edition (PSEE). When the PS&E Submittal package is complete and ready for submission, control of the PSEE model will be transferred to the appropriate office. Transfer control of the PS&E Module no later than the PS&E Transmittal Date to:

- State Program Management Office, Final Plans section, or
- District Contracts Office for district-let projects

Upon receiving control of the PS&E Module, the appropriate office (indicated above) will check the package for completeness. If incomplete, the District Final Plans Office is notified to provide a corrected submittal.

~~Prepare and post the PS&E Submittal package to the Central Office server no later than the PS&E Transmittal Date. Transfer control of the AASHTOWare Project Preconstruction™ (PrP formerly TRNSPORT) project files to the Final Plans section of the State Program Management Office, Final Plans section when transferring control of the PS&E Module, posting the PS&E Submittal Package.¶~~

~~▪ Email the Transmittal of Plans, Specifications and Estimates Package Memo (Form 131-A, see FDM 103), and the Contract File Index (Form 131-B, see FDM 103) with attachments, to CO-CPKG with a copy to the Department's Project Manager.¶~~

~~Upon receipt of the PS&E Submittal, the Central Office Final Plans section checks the package for completeness and records the date posted. If incomplete, the District Final Plans Office is notified to provide a corrected submittal. Once accepted, the PS&E Submittal is posted to the server, for access by Contracts Administration.¶~~

Commentary on Update: On 8/24/2020 by Paul Hiers.

Date of presentation:

- 131.2.2.1 – Revisions to PS&E Submittal Package

131.2.2.1.1 Revisions to PS&E Submittal Package

Revisions are modifications to the PS&E Submittal Package after it has been accepted by State Program Management Office, Central Office Final Plans section, or District Contracts Office. See **FDM 132** for information on revisions to the PS&E Submittal Package.

Commentary on Update: Removed language on 1/14/2020 for correctness.

Date of presentation: 10/1/2019 via email per Jodi Jarrell

- 131.2.2.2 – Re-Submittal of Withdrawn Projects

131.2.2.2 Re-submittal of Withdrawn Projects

Modification for Non-Conventional Projects:

Delete **FDM 131.2.2.2.**

When a District withdraws the PS&E Submittal Package for major revisions before the letting, the project must be resubmitted as a new ~~transmittal of the~~ PS&E Submittal Package with all required components. ~~Include the note “Plans Completely Revised” on the Transmittal Memo next to the Transmittal date. Include the note under the “Revisions” Header of the lead Key Sheet, “Plans completely revised (date)”.~~ Show the new Proposal/Contract ID number on the Key Sheet(s).

Project documents in Central Office from the previous submittal will be deleted. A project withdrawn for a period of nine months or longer will be updated according to the process outlined in **FDM 112**.

~~Plans rejected from letting by the Awards Committee or withdrawn for minor revisions may not need to follow the above process.~~ Districts must coordinate with Central Office Production Management or District Contract Administration to reschedule a letting.

~~Modification for Non-Conventional Projects:~~

~~Delete **FDM 131.2.**~~

FDM 132 (Plan Revisions)

Commentary on Update: Added language on 12/17/2019 then removed language on 8/5/2020.

Date of presentation: On 12/11/2019 by Scott Peterson during DRDE Meeting and secondly on 7/28/2020 by email per Jodi Jarrell

- 132.1 - General

132.1 General

This section describes the critical activities required to process the contract plans, specifications and estimate for letting. It identifies the transmittal forms, certifications and other documents prepared by the District and the various offices involved in processing a Plans, Specifications & Estimates (PS&E) Submittal Package. This chapter also outlines the revision process, ~~and the steps to resubmit a project that has been withdrawn from letting.~~

If the original professional engineer is not available to prepare a revision and is replaced by a new one, an additional signature sheet should be created listing the sheets containing the revisions they are responsible for.

Other specific requirements for processing the electronic delivery, including information on the Electronic Delivery software, can be found in the [CADD Manual](#).

Commentary on Update: On 8/24/2020 by Paul Hiers, this deletes Form 132

Date of presentation:

- 132.2 – Re-advertised and Reissued Process

132.2 Revisions to the PS&E Submittal Package

Revisions are modifications to the PS&E Submittal Package after it has been accepted by the State Program Management Office, Final Plans section or District Contracts Office Central Office Final Plans.

The Department's Project Manager ensures a revision is completed using the PS&E Module within Project Suite Enterprise Edition (PSEE) as follows ~~(see Figure 132.2.1)~~:

- (1) All revisions require a completed Revision Memo as outlined in the PS&E Module (Form 132, see FDM 103). —When access to AASHTOWare Project Preconstruction™ (formerly TRNS•PORT) is required, obtain concurrence from the District Director of Transportation Development (or designee) and forward to the State Program Management Office, Final Plans section Central Office Final Plans (CO-FINALPLANS). Concurrence may be in the form of an email that includes a summary of the revision or a signed Revision Memo. Access will then be returned to the District for a period not to exceed 2 business days.
- (2) In accordance with the Stewardship and Oversight Agreement or the project-specific Project of Division Interest (PoDI), obtain an email concurrence from FHWA prior to making revisions or requesting District access to the AASHTOWare Project Preconstruction™ ~~(formerly TRNS•PORT)~~. Include the name of the FHWA contact and the concurrence date on the Revision Memo. Major changes to plans or

- (3) → If information on the Transmittal Memo changes due to Project updates, submit a revised the Transmittal Memo must be updated within the PS&E Module whether it is a formal Revision or not.¶
- (4) → For revisions to plan sheets use a conspicuous unique numbered symbol (e.g., a numbered triangle) beside the revision that corresponds to the Plans Revision Number on the Revision Memo. Begin the revision numbering with "1" and number subsequent revisions to the contract plans set, sequentially. Place the revision date, corresponding numbered symbol for the revision, and a brief description of the revision in the Revision Block on each modified sheet. The same applies to adding sheets; however, the added sheets may be numbered with alphabetic suffix (e.g., 22A, 22B, 22C). If a sheet is being deleted, the sheet numbers for the following sheets remain unchanged. For revisions involving revised, added or deleted pay items, see Form-132 (see FDM-103). See **FDM-302** for instructions on recording a revision on the Key Sheet.¶
- (5) → The responsible professional Signs and Seals each revised document in accordance with the requirements of **FDM-130**.¶
- (6) → Prepare Complete the Revision Memo within the PS&E Module (Form-132, see FDM-103), providing a Revision Number and describing modifications. Record the revision date for each revised sheet, using the date shown in the revision block on the sheet.¶
- (7) → District Specifications must reviews the revision for any effect on the specifications, then dates and signs the Revision Memo.¶
- (8) → When the revision package is complete and ready for submission, control of the PS&E model Module will be transferred to the appropriate office (see FDM-131.2.1). The receiving office will check the revisions for completeness. Ensure that revisions to the PS&E Submittal Package are posted to the Central Office server. Email a PDF of the signed Revision Memo to Final Plans, CO-FINALPLANS.¶
- (9) → Approval from the The District Secretary's signature is required on the Revision Memo if the revision is submitted within 15 working days of the letting. ¶
- (10) → Approval from the Director of the Office of Design is required if the revision is submitted within five working days of the letting. Since there is no assurance that all prospective contractors will get these documents on time to be considered in their bids, approval for a revision within five working days of the letting is uncommon. If approval is not granted, the project will either be let as is, or be

(11) Upon email receipt of the signed Revision Memo, Central Office Final Plans will check the revisions for completeness.

(12)(11) Mandatory Specification Revisions issued from Central Office will be processed by Supplemental Specifications Package. Signatures Approvals for are not required on the Revision Memo for Mandatory Specification Revisions is not required unless other revisions are included with the package. Mandatory Specification Revision Approval is not required unless additional revisions are included in the package.

Commentary on Update: Updated Figure 132.2.1

Figure 132.2.1 District Revisions

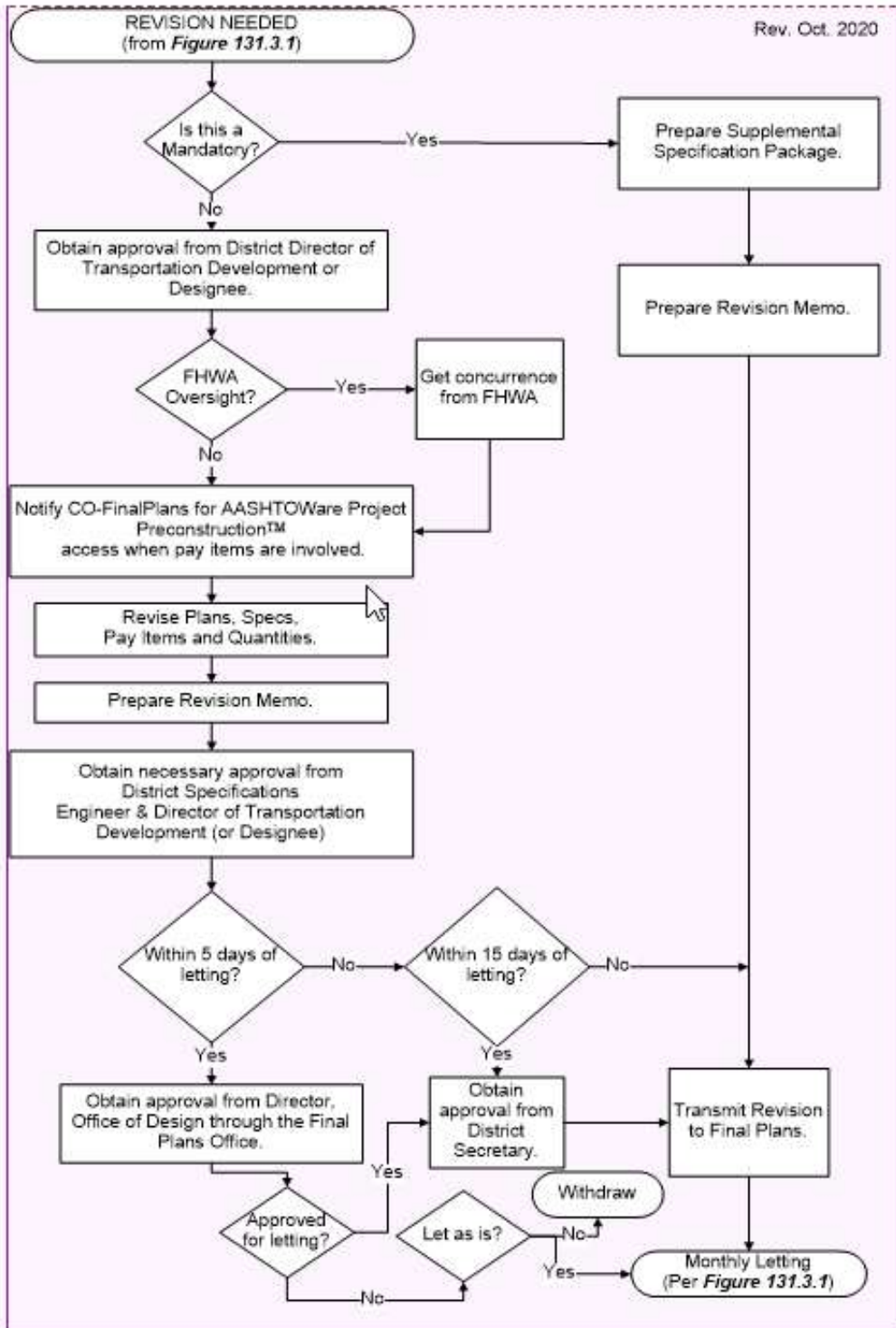

Commentary on Update: Information provided by Jodi Jarrell to provide clarity on the process

Date of presentation:

- 132.5 – Re-advertised and Reissued Process

132.5 Re-advertised and Reissued Process

A re-advertised and reissued PS&E Package occurs when a PS&E Package has been advertised/withdrawn or moved beyond advertisement. For a re-advertised and reissued PS&E Package, the Specification Package is to be revised to the current Specifications workbook. The word "REISSUED" precedes the Specifications Package date, as applicable throughout the document.

FDM 133 (Retention of Electronic Documents)

Commentary on Update: Changed to VAULT due to TIMS and PEDDS longer being used.

Date of presentation: N/A

- 133.1 – General

133 Retention of Electronic Documents

133.1 General

The documents and files created throughout the life of a project must be retained in electronic format. There are several different storage systems used for retaining these records. See **Figure 133.1.1**. As-built documents that are to be scanned for electronic storage should meet both requirements of the **Construction Project Administration Manual (CPAM), Section 5.12** and the **Transportation Technology User's Manual (FDOT Procedure No. 325-000-002)**.

Figure 133.1.1 Storage of Electronic Documents

Active VAULT	TIMS	PEDDS DATA BASE Archive VAULT	Electronic Data Management System (EDMS)			
			DESIGN EDMS	CONTRACT EDMS	CONSTRUCTION EDMS	STRUCTURES MANAGEMENT EDMS
File management system for in-house CADD file check in/out. Allows for multiple users to work on same files. Working files only. Can be used during Construction Phase to prepare As-Built Plans.			Legal Records for Department of State Requirements – Image files (PDF Version 1.7 or TIF) only. For information on Specific Document Types stored in each Group contact the Responsible Office			
Electronic Vault for Storage of electronically signed, or digital delivery files For Storage of: - Project CD - Plans and Specs CD - Revisions CD - Cat II Bridge As-Built Files Files stored in the PEDDS Database cannot be written.			Design Records Groups Architectural Community Involvement Drainage Environmental Permits Estimates FDOT Publications Geotechnical/Materials Landscaping Lighting Product Evaluation Project Management Rdwy Design Documentation Does not include Plans Roadway Resource Library Specifications Structures Structures Resource Library Tolls Facilities Traffic Design Utility Agreements NOTE: Contract Plans are not stored in the Design EDMS.	Contract Records Groups Construction Contracts: - Amendments - Bid Blank - Certificate of Insurance - Contract - Federal Aid Contract - Provisions - Permits - Pertinent Pages - Proposal - Special Provisions - Specifications - Supplemental Specifications - Utility Work Schedule - Wage Rate Supporting Construction Contract Documents: - Award Letter - Correspondence - Daily Diaries - Execution Letter - Final Estimates Package Work Progress NOTE: Contract Plans are not stored in the Contracts EDMS.	Construction Records Groups Claims Compliance Contract Changes Includes Design Errors and Omissions, Field SA/Work Orders, and SA/Change Orders Contract Documents As-Built Plans Daily Diary Estimates Final Estimates General Correspondence Job Correspondence Material Sampling and Reporting Pre-Letting Includes Design Correspondence Quality Assurance/Quality Control Service Contracts Working Drawing Transmittals Structure Sublet Work Time Correspondence Unpaid Bills Utility	Maintenance Records Groups Bridge Plans and Specifications Bridge Record Bridge Working Drawings Correspondence Geotechnical High Mast Record Sign Record Structural Calculations - As-Bid Plans - As-Built Plans - Repair As-Bid Plans - Repair As-Built Plans - Widening As-Bid Plans - Widening As-Built Plans

FDM 140 (Lump Sum Projects)

Commentary on Update: On 9/4/2020 by Paul Hiers

Date of presentation:

- 140.3 – Plans Preparation

140.3 Plans Preparation

Plan content should conform to the requirements of **Part 3 or Part 9**, subject to the guidance provided herein. Designers should detail plans, either by detailed drawings or plan notes, to clearly describe the work to be performed by the contractor. ~~Special care should be used to insure pay item notes and other notes~~ **Notes** and requirements **must provide specific direction and details that can be properly bid on by the Contractor; avoid notes containing such as** “as directed by the Engineer” ~~are deleted or replaced with specific direction and details that can be properly bid on by the Contractor.~~

~~The following are some of the desired elements in a set of Lump Sum plans:~~

~~A pay item note placed on the Summary of Pay Items sheet stating, “999-2 Lump Sum Contract. All other Pay item numbers shown in the Contract Plans are provided only for the purpose of describing the work to be performed. Pay item descriptions are found in the Department’s **Basis of Estimates Manual**.” This note only needs to be placed the one time on this sheet. It should not be repeated on any other sheets within the Contract Plans.~~

- ~~(1) → Typical Sections.~~
- ~~(2) → Milling, resurfacing and overbuild details to show any cross slope corrections, including existing pavement cross slope information.~~
- ~~(3) → Document quantities for all work to be performed on the project by location in the summary boxes Estimated Quantities Report for Roadway and Structures disciplines or on a tabulation of quantities sheet for all other disciplines. **Note: Summary boxes and tabulation sheets should not have totals. The standard summary boxes contained in the FDOT CADD software should be used.**~~

Commentary on Update: On 9/4/2020 by Bobby Bull.

Date of presentation:

- 140.7 – Construction Contract Administration

Construction inspection personnel should not be required to document quantities except for asphalt and other items subject to pay adjustments (items with predetermined unit prices). Measurement and completion of “Final” quantity for summary boxes on plan sheets Estimated Quantity Report is not required. Focus should be on inspection and achieving a quality final product. For example, the Project Engineer will not be concerned with how many square yards of sod it takes or the number of miles of final striping. The Project Engineer will be charged with ensuring that the sod, striping, embankment, and pipe meets the lines and grades of the plans and specifications.

FDM 200 (Context Based Design)

Commentary on Update: On 9/8/2020 by DeWayne Carver

Date of presentation:

- 200.4 – Context Classification

200.4 Context Classification

Projects are uniquely planned and designed to be in harmony with the surrounding land use characteristics and the intended uses of the roadway. To this end, a context classification system comprising eight context classifications has been adopted. **Table 200.4.1** describes the context classifications that will determine key design criteria elements for arterials and collectors.

Criteria for LA Facilities are independent of the adjacent land uses; therefore, context classifications shown in **Table 200.4.1** do not apply to these facilities.

Additional information on context classifications and guidance on the determination of the context classification is provided in the [FDOT Context Classification Document](#) **FDOT Context Classification Guide**.

FDM 201 (Design Controls)

Commentary on Update: Changed language to refer to the Pavement Design Manuals on 1/13/2020

Date of presentation: 11/19/2019 via email per Mary Jane Hayden

- 201.3 – Traffic and Design Year

Traffic forecasting is also used in pavement design to determine the vehicular loadings on the pavement. The proposed pavement design must provide structural strength through the pavement's service life. ~~Refer to the On pavement rehabilitation, the service life is 8 – 20 years for projects without milling and 12 – 20 years for projects with milling. The FDOT Pavement Design Manuals provide for guidance on selecting an appropriate design period for flexible and rigid pavements.~~

FDM 202 (Speed Management)

Commentary on Update: Change on 5/27/2020 by DeWayne Carver

Date of presentation:

- 202.2 – Speed Management Concepts

Table 202.3.1 indicates the appropriate context classification, ~~design speed~~ **Target Speed** range, and potential techniques that may be applicable to achieve the indicated ~~design speed~~ **Target Speed**. The strategies shown in this table are not exhaustive. Creativity, judgment, and experience in the use of low speed strategies are encouraged. Successful strategies typically incorporate one or more of the following speed management concepts:

Commentary on Update: Change on 8/26/2020 by James McGinnis.

Date of presentation:

- 202.3.7 – Short Blocks

Where physical short blocks already exist, such as most C6 and C5 contexts and many C4 and C2T contexts, consider marking crosswalks at unsignalized intersections to reinforce the presence of the short blocks; see **FDM 222.2.3.1** and **Traffic Engineering Manual (TEM) 5.2** for criteria on marking unsignalized crosswalks. This concept is illustrated in **Figure 202.3.2**.

Commentary on Update: Change on 5/27/2020 by DeWayne Carver

Date of presentation:

- 202.3.8 – Speed Management Concepts

▲ 202.3.8 Vertical Deflection

Like horizontal deflection, vertical deflection is a proven technique for speed management. Speed tables and raised intersections may be considered only for **design speed Target Speeds** of 25 mph or less. Raised crosswalks may be considered for **design speed Target Speeds** of 30 mph or less. High levels of engagement with local public works and emergency services are required when vertical deflection is proposed.

Commentary on Update: Changed on 5/21/2020 by Gevin McDaniel.

Date of presentation:

- 202.3.9 – Speed Feedback Signs

The signs provide immediate feedback to drivers when the speed limit is exceeded, which may help to reduce unintentional speeding. They are most effective at managing operating speeds for short distances (about 1,000 feet) following the sign and when combined with other measures such as high emphasis crosswalk markings and **median** islands. Coordinate with the District Traffic Operations Engineer on the use of this device.

Commentary on Update: Changed on 5/21/2020 by Gevin McDaniel.

Date of presentation:

- 202.3.11 – Speed Feedback Signs

<p>202.3.11 Median Islands</p> <p>Median islands (refuge islands) at crossings can provide deflection as well as engagement to help manage operating speeds. Unlike continuous raised medians, median islands are short sections of raised median used in specific locations. When combined with a crosswalk, the median island may provide refuge for pedestrians as well as speed management. See FDM 210 and FDM 212.13.2 for median island criteria.</p> <p>Median islands on curved roadway sections can prevent centerline crossing lane departures by forcing drivers to stay within the travel lane. These are especially effective in locations where drivers increase speed by overrunning the centerline striping on a shorter-radius curve.</p>
--

Commentary on Update: On 8/26/2020 by James McGinnis.

Date of presentation:

- 202.3.13 – Rectangular Rapid Flashing Beacons and Pedestrian Hybrid Beacons

<p>202.3.13 Rectangular Rapid Flashing Beacons and Pedestrian Hybrid Beacons</p> <p>The Rectangular Rapid Flashing Beacon (RRFB) and Pedestrian Hybrid Beacon (PHB) traffic control devices are “beacons” rather than signals and consequently have a less restrictive warranting processes. When combined with marked crosswalks, they can be used to establish shorter block lengths. They may also create engagement and thereby help manage operating speeds. See TEM 3.8 TEM 5.2 and coordinate with the District Traffic Operations Engineer on the application of these devices.</p>
--

Commentary on Update: On 5/27/2020 by Gevin McDaniel.

Date of presentation:

- Table 202.3.1 – Strategies to Achieve Desired Operating Speed

Context Classification	Design Speed Target Speed (mph)	Strategies
C1	55-70	Project-specific; see FDM 202.4 .
C2	55-70	Project-specific; see FDM 202.4 .
C2T	40-45	Roundabout, Lane Narrowing, Horizontal Deflection, Speed Feedback Signs, RRFBS and PHBs
	35	Techniques for 40-45 mph, plus On-street Parking, Street Trees, Short Blocks, Median Islands at Crossings, Road Diet, Bulbouts , Terminated Vista
	30	Techniques for 35-45 mph, plus Chicanes, Median Islands in curved sections, Textured Surface
	≤ 25	Techniques for 30-45 mph, plus Vertical Deflection
C3R, C3C	50-55	Project-specific; see FDM 202.4 .
	40-45	Roundabout, Lane Narrowing, Horizontal Deflection, Speed Feedback Signs, RRFB and PHB
	35	Roundabout, Lane Narrowing, Horizontal Deflection, Speed Feedback Signs, Median Islands in crossings, Road Diet, RRFB and PHB, Terminated Vista
C4	40-45	Roundabout, Lane Narrowing, Horizontal Deflection, Speed Feedback Signs, RRFB and PHB
	35	Techniques for 40-45mph plus On-Street Parking, Street Trees, Short Blocks, Median Islands at Crossings, Bulbouts , Terminated Vista, Road Diet
	30	Techniques for 35-45 mph plus Chicanes, Median Islands in Curve Sections, Textured Surface
C5	35	Roundabout, On-street Parking, Street Trees, Short Blocks, Speed Feedback Signs, Median Islands in Crossings, Road Diet, Bulbouts , RRFB and HAWK, Terminated Vista
	30	Techniques for 35 mph plus Chicanes, Median Island in Curve Sections, Textured Surface
	25	Techniques for 30-35 mph plus Vertical Deflection
C6	30	Roundabout, On-Street Parking, Horizontal Deflection, Street Trees, Median Islands in Curve Sections, Road Diet, Bulbouts , Terminated Vista, Textured Surface
	25	Techniques for 30 mph plus vertical deflection

FDM 210 (Arterials and Collectors)

Commentary on Update: 5/20/2020 by Gevin McDaniel

Date of presentation:

- 210.2 – Lanes

210.2	Lanes
<p>Design criteria for lane widths and pavement slopes are given by lane type, design speed and context classification. Minimum travel, auxiliary, and two-way left-turn lane widths are provided in Table 210.2.1. Refer to FDM 211 for ramp lane widths.</p> <p>Two-way left turn lane widths (flush median) may be used on 3-lane and 5-lane typical sections with design speeds ≤ 40 mph. On new construction projects, flush medians are to include sections of raised or restrictive median <u>and islands</u> to enhance vehicular, bicycle, and pedestrian safety, improve traffic efficiency, and attain the standards of the Access Management Classification of that highway system. Sections of raised or restrictive median <u>and islands</u> are recommended on RRR projects.</p>	

Commentary on Update: Changed on 2/27/2020 and again on 9/18/2020 by James McGinnis

Date of presentation:

- Table 210.2.1 – Minimum Travel and Auxiliary Lane Widths

Auxiliary Lanes:
<p>(1) Auxiliary lanes are typically the same width as the adjacent travel lane.</p> <p>(2) Table values for right turn lanes may be reduced by 1 foot when a bicycle keyhole is present.</p> <p>(3) Median turn lanes should not exceed 15 feet in width.</p> <p><u>(4)</u> For high speed curbed roadways, 11-foot minimum lane widths <u>are allowed for the following:</u></p> <ul style="list-style-type: none"> • for Dual left turn lanes • Single left turn lanes at directional median openings are allowed. • <u>For high speed curbed roadways, 11-foot minimum lane widths for directional median openings are allowed.</u> <p>(4)<u>(5)</u> For RRR Projects, 9-foot right turn lanes on very low speed roadways (design speed ≤ 35 mph) are allowed.</p>

Commentary on Update: Changed on 2/27/2020 by James McGinnis

Date of presentation:

- 210.2.4 – Pavement Cross Slopes

<p>210.2.4 Pavement Cross Slopes</p> <p>For roadways, the maximum number of travel lanes with cross slope in one direction is three lanes except as shown in Figure 210.2.1, which prescribes standard pavement cross slopes. A Design Variation or a Design Exception is required when proposed pavement cross slopes do not meet the requirements shown in Figure 210.2.1.</p> <p><u>Outside auxiliary lane cross slopes must match or exceed adjacent travel lane cross slope. The outside auxiliary lane cross slope cannot exceed the values in Figure 210.2.1. In superelevation transitions for separated free flow turning movement roadways, do not exceed the maximum algebraic differences shown in Table 210.2.2.</u></p> <p><u>Is match adjacent travel lanes except at intersections. For intersection information see FDM 212.</u></p>

Commentary on Update: 5/4/2020 by James McGinnis.

Date of presentation:

- Table 210.2.3 – RRR Criteria for Existing Roadway Cross Slopes

<p>Notes:</p> <p>(1) Existing multilane curbed roadways may have outside travel or auxiliary lanes with a maximum cross slope of 0.05.</p> <p>(2) Outside auxiliary lanes on flush shoulder roadways auxiliary lanes must match or exceed adjacent travel lane cross slopes with a maximum cross slope of 0.04.</p> <p>(3) The maximum algebraic difference between adjacent through lanes must not exceed 0.06.</p> <p>(4) When existing shoulders are to remain, the algebraic difference between the shoulder slope and adjoining roadway pavement slope must be ≤ 0.07.</p> <p>(5) Parking spaces and access aisles dedicated to serving persons with disabilities must have cross slopes no steeper than 0.02 (1:50) in any direction.</p>
--

Commentary on Update: Changed on 5/7/2020 & 5/20/2020 by Gevin McDaniel

Date of presentation:

- 210.3 – Medians, Islands, and Hardened Centerlines

<p>210.3 Medians, and Islands, and Hardened Centerlines</p> <p>210.3.1 Medians</p>
--

Provide a raised or restrictive median (i.e., not a two-way left turn lane or centerline pavement marking) on divided ~~curbed~~ roadways that have a design speed of 45 mph or greater. Median widths for divided roadways are given in **Table 210.3.1**.¶

210.3.1 — Bridge Median

Commentary on Update: On 5/7/2020 by James McGinnis.

Date of presentation:

- 210.3.2 - Islands

~~212.13~~210.3.2 Islands

An island is an area between traffic lanes that provide one or more of these primary functions:

- (1) Channelization Islands:— to control and direct traffic movement (usually turning) at intersections or driveways.
- (2) ~~Division~~ (Median Islands and Traffic Separators):— to divide separate traffic in opposing or same direction traffic (usually through movements), manage access

points and turning movements, provide for delineation of narrow roadway medians, and provide for drainage. Typically referred to as “divisional islands” when separating traffic in opposing directions.

- (3) Refuge Islands:— to provide refuge for pedestrians.

Islands are generally elongated or triangular in shape and located in areas where motorized vehicle use is restricted. The placement of mast arms in channelizing islands is discouraged. ~~The placement of mast arms in median islands is not permitted.~~

Island delineation is divided into three types:

- (1) Curbing that raises the island
- (2) Pavement markings or reflectorized markers placed on paved areas
- (3) Pavement edges, possibly supplemented by ~~flexible~~ delineators ~~or other flexible~~ guideposts, or a mounded-earth treatment beyond and adjacent to the pavement edges.

Delineation of small islands is primarily by curbs. Large curbed islands may be sufficiently delineated by color and texture contrast of vegetative cover, mounded earth, shrubs, ~~guideposts, tubular markers,~~ signs or any combination of these. Use tubular markers at island noses as channelizing devices in addition to delineation. Curbed islands should not be used on high speed flush shoulder roadways. Standard markings for islands are provided in the **Standard Plans, Index 711-001**.

Commentary on Update: On 5/7/2020 by Gevin McDaniel and on 6/24/2020 by Benjamin Gerrell.

Date of presentation:

- 210.3.2.1 – Channelization Islands

~~212.13.1~~ **210.3.2.1 Channelization Islands**

Islands must be large enough to command attention. Meet the following requirements when designing channelization islands:

- (1) The preferred size of Curbed islands should have an area of beis 100 square feet or morelarger, however, must not be less than:
 - (a) 50 square feet or larger within Ffor curbed intersections within C4, C5, or C6 Context Classification, the size should not be less than 50 square feet.
 - (b) 75 square feet or larger ff for flush shoulder intersections within C1, C2, C2T or C3 Context Classification, the size should not be less than 75 square feet.
 - (c) 100 square feet or larger for all other locations.
- (2) Triangular islands should be at least 15 feet on a side, but not less than 12 feet, after rounding of corners.
- (3) Side dimensions of curbed islands should not exceed 100 feet on high speed roadwaysfacilities (e.g., high speed curbed roadway), p. 722

The approach and departure noses are rounded with radii of at least 3.5 feet. **Figure 2102.13.1** illustrates a small island with a parallel offset. **Figure 2102.13.2** illustrates a large island with a taper offset.

Commentary on Update: On 5/7/2020 by Gevin McDaniel.

Date of presentation:

- Figure 210.3.1 – Typical Small Curbed Island

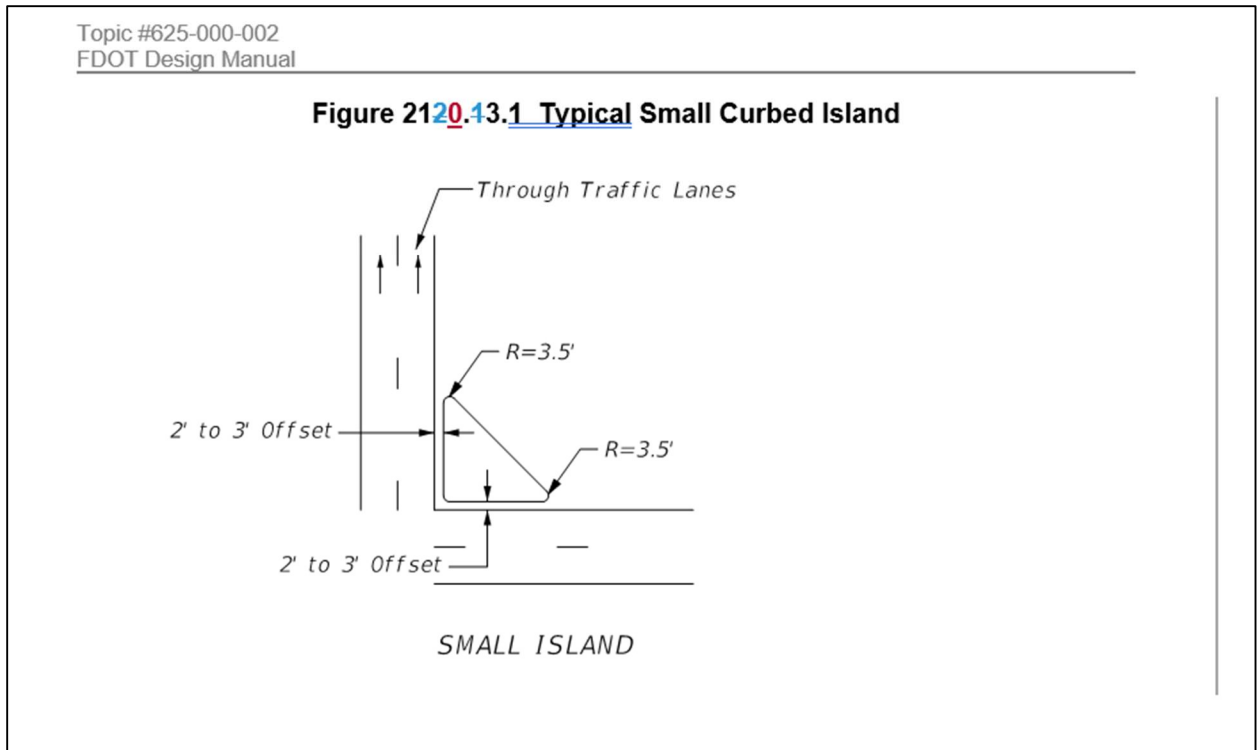

- *Figure 210.3.2 – Typical Large Curbed Island*

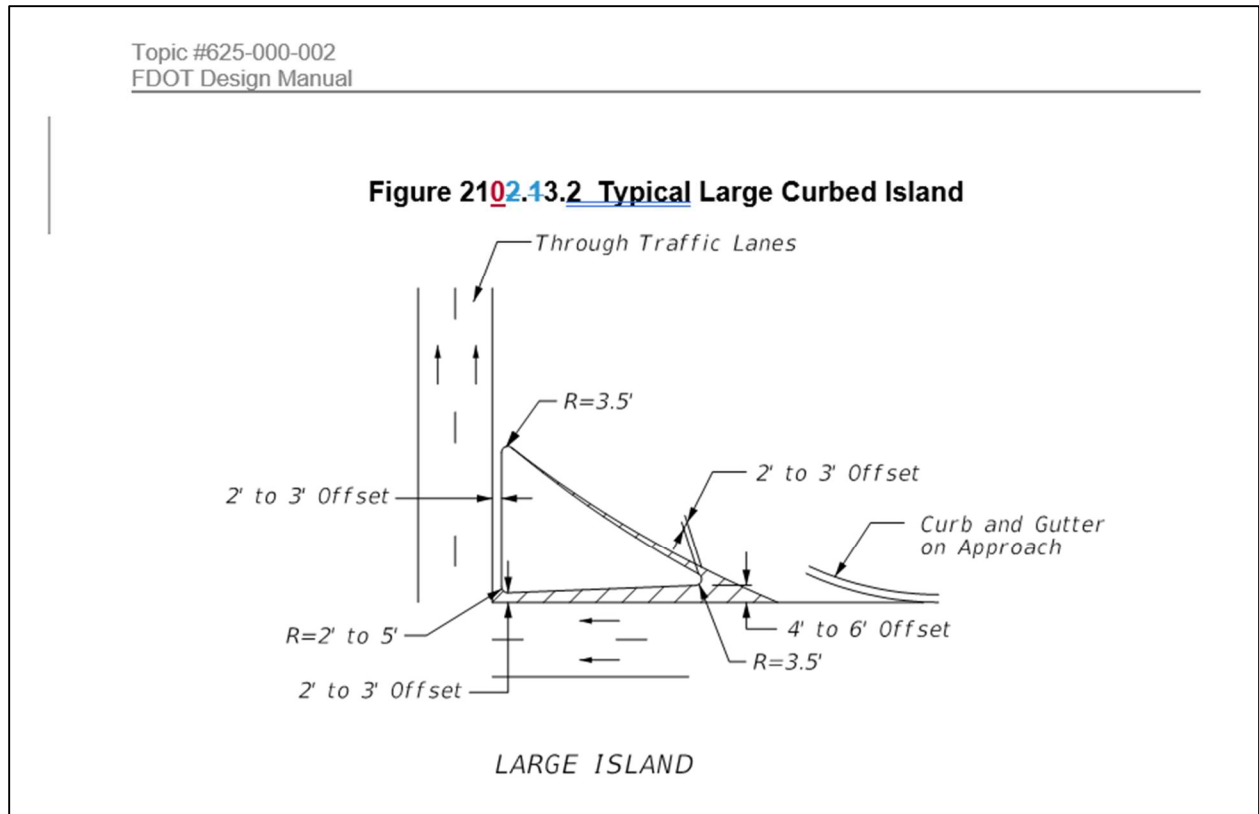

Commentary on Update: On 5/7/2020 by Gevin McDaniel.

Date of presentation:

- 210.3.2.2 – Median Islands and Traffic Separators

210.3.2.2 212.13.2 Median Islands and Traffic Separators

Meet the following requirements when designing median islands and traffic separators:

- (1) A minimum of 4 feet wide and 25 feet long.
- (2) 100 feet or more in length is allowed on high speed roadways when providing high visibility for the islands.

Topic #625-000-002
FDOT Design Manual

- (3) Approach noses should be offset 2 to 6 feet from the through (approach) lanes to minimize impacts. Pavement markings in advance of the nose can be used to transition from the centerline to the edge of island.
- (4) The shape of the island should be based on design turning paths and the island function. Curvilinear tapers comprised of parabolic or circular curves generally suffice.
- (5) The length of the island should be related to the approach speed. An estimate is to use the length based on 3-second driving time to the intersection.
- (6) Median islands should begin on tangent alignments and on upgrades or beyond crest vertical curves. In some cases it is appropriate to extend a median island to avoid its introduction on a horizontal curve or within an area of limited sight distance.
- (7) Approach noses must extend across the crosswalk at intersections to control left-turn speeds and encourage pedestrian use of the crosswalk. Use tubular markers as shown in the figures as channelizing devices.
 - (a) For median widths greater than or equal to 6 feet, use a refuge island. **Figures 210.3.X3 and 210.3.X** illustrates the geometrics for curbed roadways (i.e., standard 6-foot nose extension and minimum nose extension for RRR projects).
 - (b) For median widths less than 6 feet, use hardened centerlines. See **FDM 210.3.3** for hardened centerlines. Use tubular markers as shown in the figures as channelizing devices, or more information on crosswalks at intersections.

Standard Plans, Index 520-020 provides detailed dimensional design for traffic separators.

See FDM 222.2.3.1 for more information on crosswalks at intersections.

Commentary on Update: On 5/7/2020 by Gevin McDaniel.

Date of presentation:

- 210.3.2.3 – Refuge Islands

210.3.2.3 212-13.3 Refuge Islands

Refuge islands provide an area for pedestrians and bicyclists to stop before finishing the crossing of a roadway. Complex intersections can be made more navigable and midblock crossing can be facilitated with refuge islands. Refuge islands are commonly raised curb corner islands (a.k.a., “pork chop islands”) and center channelizing or divisional islands. Refuge islands have specific design criteria to support pedestrian or bicyclist movement.

Refuge islands ~~should~~ **must** be a minimum of 6 feet wide m face of curb to face of curb in the dimension between the traveled ways; however, the preferred width is 8 feet or greater when they will be used for bicyclists. For curbed roadways, this dimension is

Topic #625-000-002
FDOT Design Manual

from face of curb to face of curb. Consider the refuge island's storage capacity for higher volumes of pedestrian and bicycle traffic, as well as the space needed for pedestrians or bicyclists with items such as strollers, wheelchairs, wagons, cargo bikes, box bikes, and bikes with trailers.

~~Pedestrians and bicyclists should have~~ Provide a clear path through the island without and should not be obstructioned by objects such as poles, sign posts, or utility boxes. The width of the clear path through the island must be at least 5 feet to meet ADA requirements and should be equal to the width of the crosswalk. See **Figure 210.3.3X**. See **FDM 213.3.5** for additional dimensional requirements for roundabout splitter islands. See **FDM 222.2.3.2** for more information on midblock crossings. For more information on depressed and raised sidewalks, see **Standard Plans, Index 522-002**.

Refuge islands may be enhanced by low-~~height~~growing landscaping and stormwater management features. See **FDM XXX** (Drainage), **Drainage Manual**, and **FDM XXX228** (Landscape Designing).

Examples of ~~pedestrian~~-refuge islands at midblock crossings are shown in **Figures 212210. 13.43** and **212210. 13.54**.

For more information on pavement markings, see **Standard Plans, Index 711-001**.

FDM 212.12 provides information on the design of turning roadways with corner islands.

Roundabout splitter islands provide pedestrian refuge and are discussed in **FDM 213.3.5**.

Figure-210.-3.3-Protected-Intersection-Pedestrian-Refuge-Island-Crosswalk

For New and Reconstruction Projects with Raised Crossings:

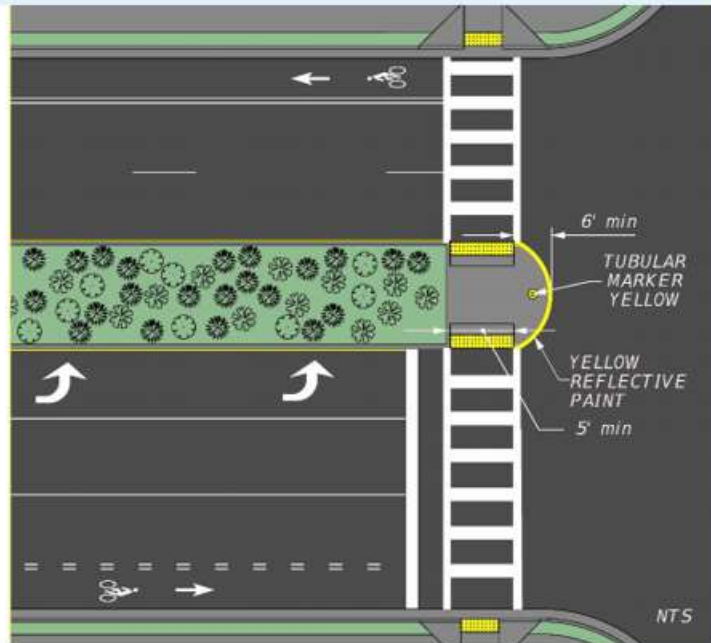

Notes:

- Raised crossing shown - depressed crossing similar.
- The path through the island is typically the same width as the crosswalk.
- The island must be a minimum of 6 feet in width measured from face of curb to face of curb.
- → The median nose must be a concrete separator as shown in Standard Plan 520-020. Match the curb profile that is used for the adjacent median.

Figure 210.3.3 Intersection Refuge Island (Cont.)

For New and Reconstruction Projects with Depressed Crossings - RRR Projects:

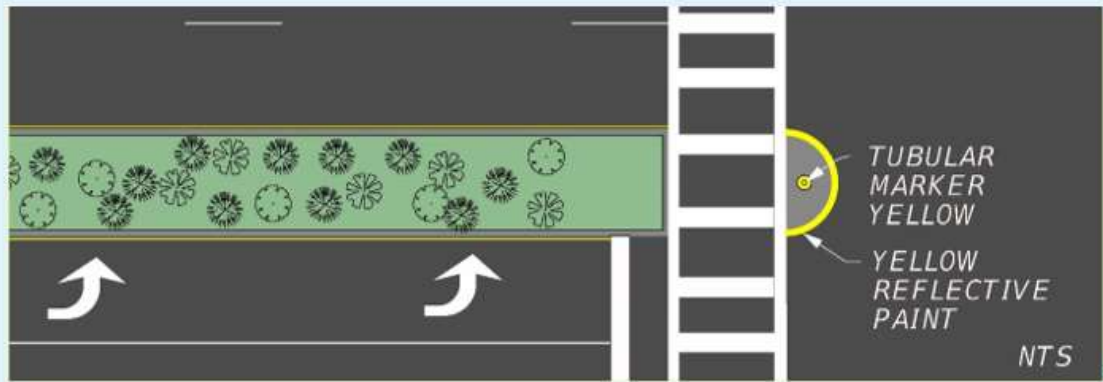

Depressed crossing shown, raised crossing similar.

For RRR Projects Where Concrete Median Nose is Not Constructible in Constrained Conditions:

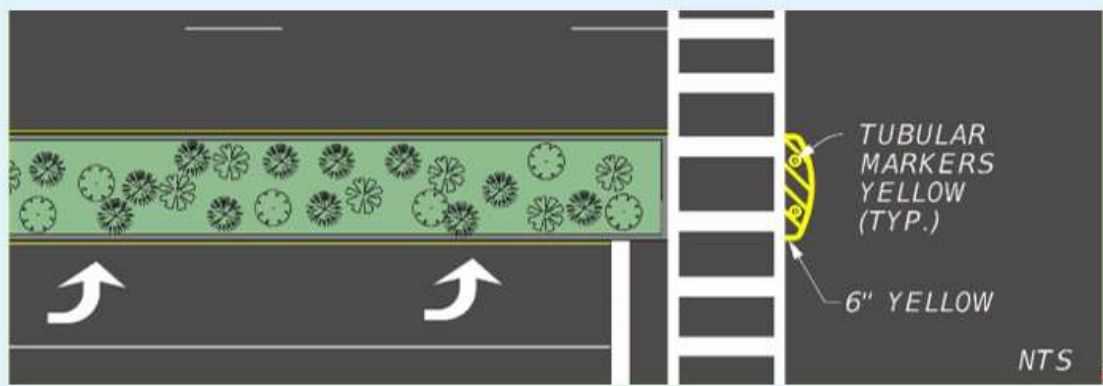
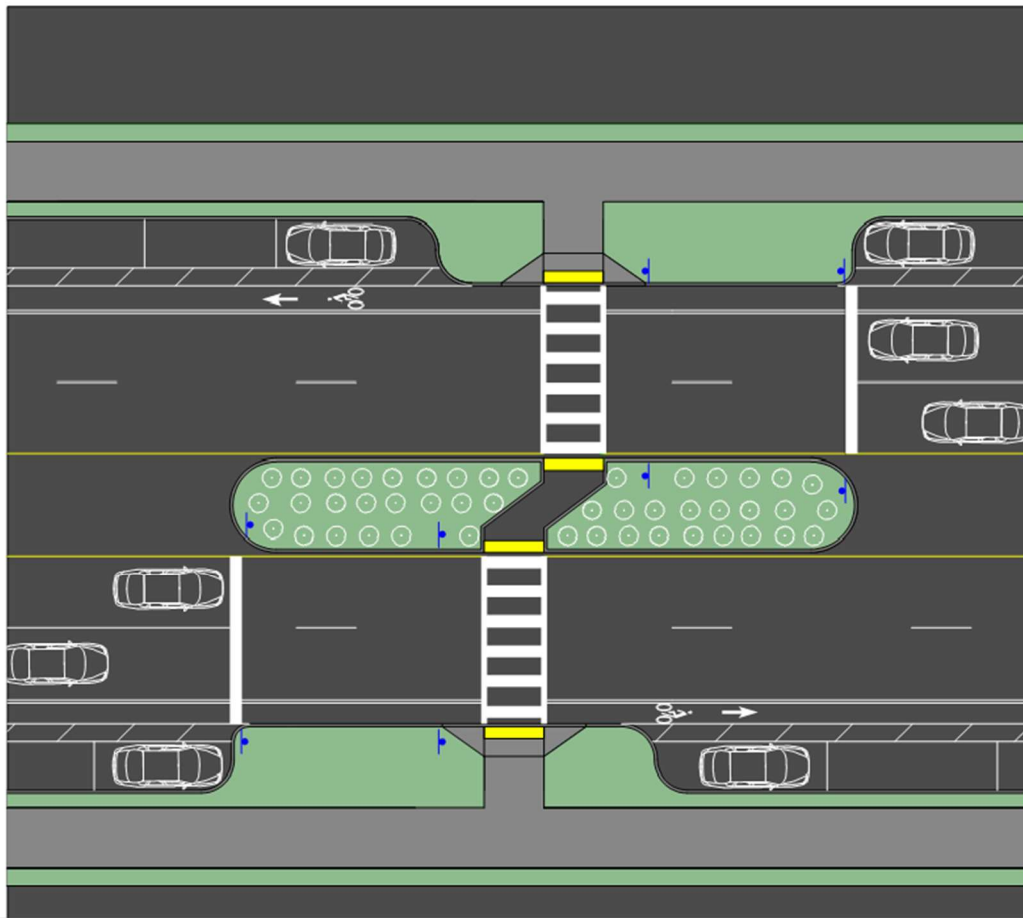
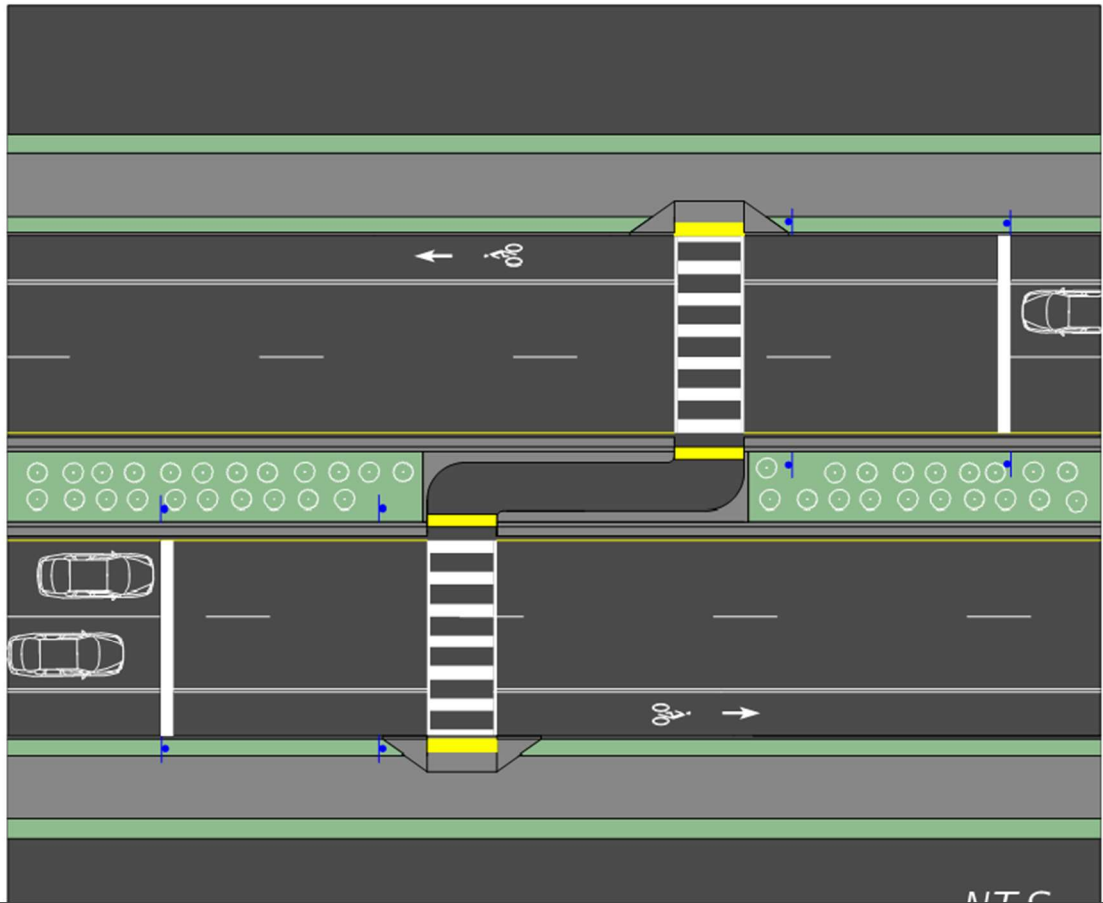

Figure 242210_13.43 Midblock Pedestrian Refuge Island Example #1



Topic #625-000-002
FDOT Design Manual

Figure ~~212~~210.13.54 **Midblock Pedestrian Refuge Island Example #2**



Commentary on Update: 5/7/2020 by Gevin McDaniel.

Date of presentation:

- 210.3.2.4 - Corner Islands

210.3.2.4 212.13.4 Corner Islands

Commentary on Update: 5/26/2020 by Gevin McDaniel.

Date of presentation:

- 210.3 - Hardened Centerlines

210.3.3 Hardened Centerlines

Hardened Centerlines are an extension of the traffic separator or centerline past the crosswalk. Hardened Centerlines improve pedestrian safety by ~~offer left turning movements by~~ reducing the turning speeds of left-turning motorists and by improving their approach angle to the crosswalk to ~~increase~~ increasing pedestrian visibility ~~by improving the approach angle to the crosswalk.~~

Provide a hardened centerline ~~where it is not possible to provide a pedestrian refuge island~~ provide a hardened centerline. ~~to slow turning speeds of vehicles and improve angle of left turning vehicles for pedestrian visibility.~~

The nose extension can be no less than 2 feet long and must provide 1-foot of clear distance from the edge of the crossing traffic lane or bicycle lane.- A 6-foot nose extension is preferred, but the designer can adjust the length to balance control of the left turning vehicle with the design vehicle turning path.

Where applicable, ~~Use~~space multiple tubular markers at a minimum spacing of 2 feet and a maximum spacing of 5 feet apart. Provide tubular markers for a minimum of 25 feet along the traffic separator or centerline approaching the crosswalk.

If tubular markers on the leading nose extension are not practicable to accommodate sight distance or turning radii, use a "channelizing curb" for the leading nose extension. Products acceptable for use (without vertical elements) as channelizing or mountable curb are currently on the **APL** under **Specification 102** Use **Developmental Specification Dev703** for channelizing curb. -

Detail channelizing or mountable curb in the plans with showing the following range of dimensions-length of the for the nose extension as described above.: Channelizing curb products are typically prefabricated in 6-foot lengths with additional length for the end-caps.

Hardened centerlines may be used with offset left turn lanes.

Commentary on Update: 5/26/2020 by Gevin McDaniel.

Date of presentation:

- Figure 210.3.6 - Hardened Centerline with Traffic Separator

Figure 210.3.6 Hardened Centerline with Traffic Separator

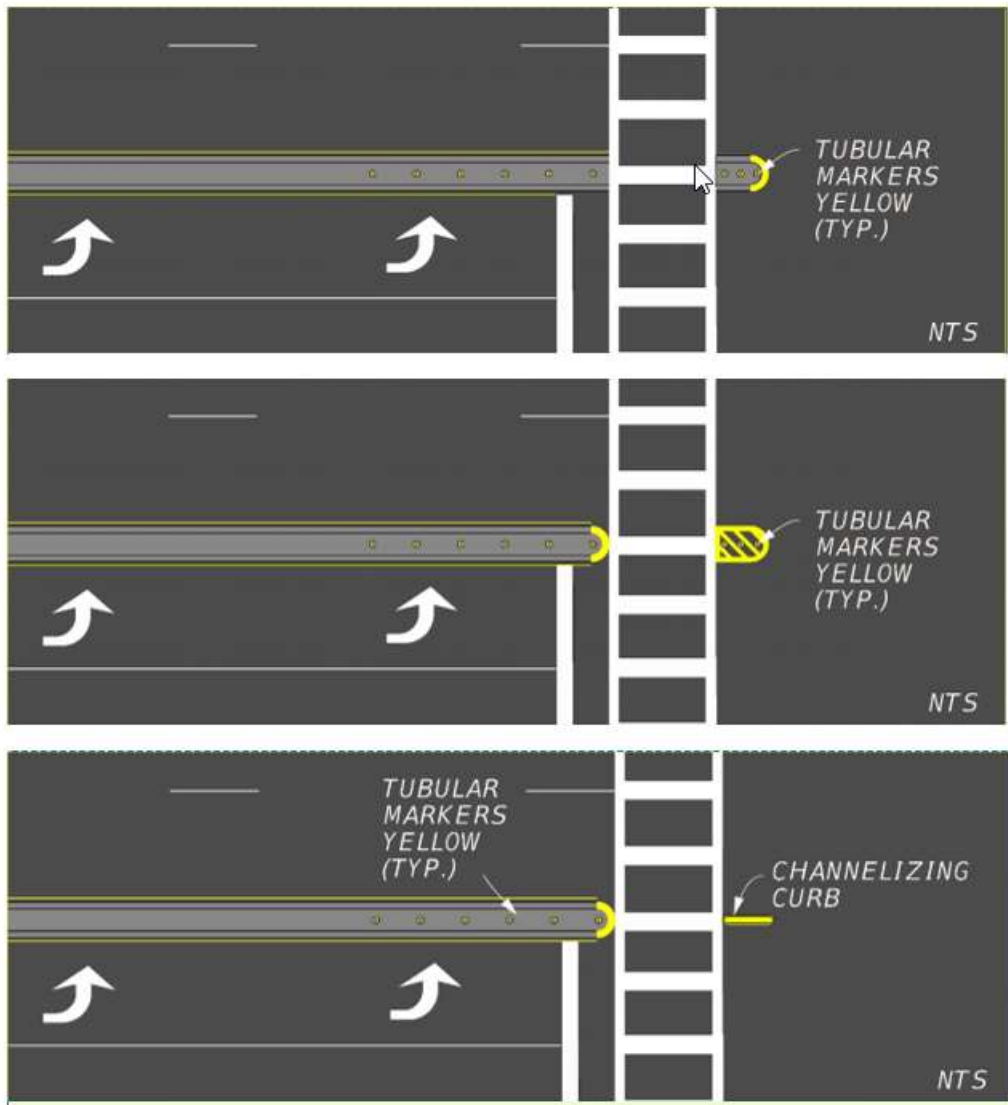

Commentary on Update: 5/26/2020 by Gevin McDaniel.

Date of presentation:

- Figure 210.3.7 - Hardened Centerline without Traffic Separator

Figure 210.3.7 Hardened Centerline without Traffic Separator

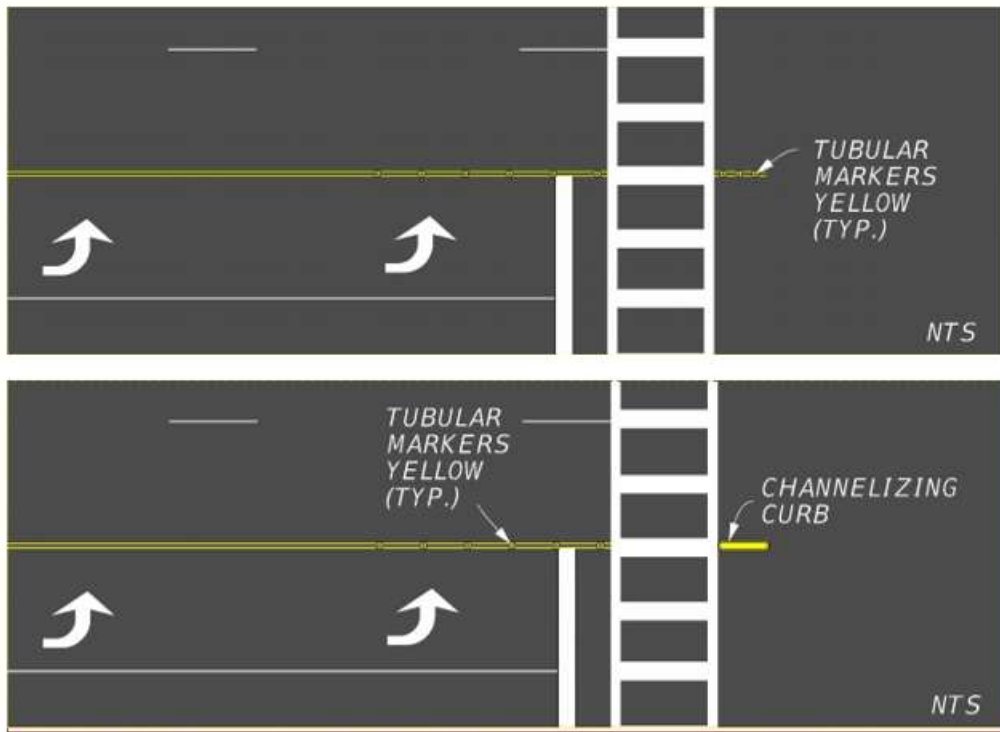

Commentary on Update: 7/9/2020 by Bobby Bull- Information brought over from the FDOT Drainage Design Manual

Date of presentation:

- 210.4 Shoulders

210.4 Shoulders

Roadway shoulder width is measured from the edge of the traveled way to the shoulder break. A portion of the shoulder is required to be paved on all roadways on the State Highway System. A paved shoulder is the portion of the roadway contiguous with the traveled way for accommodation of errant vehicles, stopped vehicles, bicycle traffic, and emergency use. Shoulder widths for roadways are given in **Table 210.4.1**. See **Figure 210.4.1** for an illustration of roadway shoulders. Refer to **FDM 211** for ramp shoulder widths. Refer to **FDM 260.3** for bridge shoulder widths.

Use shoulder gutter for the following conditions:

- On embankments higher than 20 feet
- On embankments higher than 10 feet where the longitudinal slope is greater than 2 percent
- On embankments, with slopes steeper than 1:6 for more than five feet vertically, to minimize erosion
- At bridge ends where concentrated flow from the bridge deck otherwise would run down the slope
- In areas of guardrail where embankment slopes are steeper than 1:4 and any pavement is sloped toward the embankment.

Commentary on Update: Changed on 4/7/2020 to relocate the note referring to RRR to be at the bottom, as the format throughout the FDM. Also, restructured the notes to make the original apparent A or B or C option to correctly read as an A and B option, with B having two variants.

Date of presentation: 12/9/2019 via email per Ryan Raghunandan

- Table 210.4.1 – Standard Shoulder Widths

	<p>(5) For 1-lane, 2-lane, and 3-lane median or left shoulders:</p> <p>(a) Pave 2-feet wide where turf is difficult to establish.</p> <p>(b) Pave 4-feet wide: (1) in sag vertical curves, 100 feet minimum either side of the low point, and (2) on the low side of superelevated traffic lanes extending through the curves and approximately 300 feet beyond the PC and PT.</p> <p>(6) Pave the entire width of shoulders adjacent to concrete barriers. See FDM 215.4.6.1.</p> <p>(7) For RRR Projects:</p> <p>(a) an existing full width shoulder of 6-foot or greater may be retained, and</p> <p>(b) the following minimum existing paved shoulder widths may also be retained:</p> <p>i. 4-foot paved outside shoulder adjacent to travel lane</p> <p>ii. 2-foot paved outside shoulder adjacent to auxiliary lane</p> <p>(6) For RRR Projects, the following may be retained:</p> <p>(a) existing 6-foot or greater full width shoulder</p> <p>(b) existing 4-foot paved outside shoulder adjacent to travel lane</p> <p>(c) existing 2-foot paved outside shoulder adjacent to auxiliary lane</p>
	<p>(7) Pave the entire width of shoulders adjacent to concrete barriers. See FDM 215.4.6.1.</p> <p>With shoulder gutter:</p> <p>(1) Paved shoulders less than 6 feet in width with adjoining shoulder gutter must be the same type, depth and cross slope as the roadway pavement.</p> <p>(2) Shoulders must extend 4 feet beyond the back of shoulder gutter and have a 0.06 cross slope back toward the gutter.</p> <p>(3) Required shoulder widths for auxiliary lanes typically match those of the adjacent roadway.</p>

Commentary on Update: Commentary on Update: Changed on 1/3/2020 based on DRDE comments

Date of presentation: 10/3/2019 via email per Ed Ponce

- 210.5.1 High-Speed Curbed Roadways

▲ 210.5.1 High-Speed Curbed Roadways

Curbs may be used on roadways where the anticipated operating speeds require a design speed of 50-55 mph and:

- (1) Curbs are necessary to control drainage, or
- (2) R/W is constrained

High speed curbed sections are typically used within C3 context classification and transitional areas.

High speed curbed roadways are to use Type E curb on both the median and outside. Provide an offset from the edge of the traveled way to the lip of gutter as follows:

- (1) 4-foot to median curb for 4-lane roadway sections.
- (2) 6.5-foot to median curb for 6-lane roadway sections.
- (3) 6.5-foot to outside curb for all roadway sections.

The above median offsets are not required for left turn lanes adjacent to traffic separators or Type E curb.

Commentary on Update: Commentary on Update: Revised language moved from FDM 215

Date of presentation:

- 210.6 Roadside Slopes

The following guidance is being provided to designers for consideration during project design. Additional sod requirements are provided in the **FDOT Drainage Design Manual** and in the **Standard Plans, Indexes 570-001** and **571-010**.

- Sod should be considered for slopes 1:4 or steeper. For all other areas, refer to **FDOT Drainage Design Manual**, Chapter 2, Table 2.5, for additional guidance on maximum velocity for each lining type.
- Sod should be used for projects with less than 10,000 square feet of disturbed area.
- Sod should be considered for narrow areas less than six feet.
- A minimum 48" of sod should be considered for back of sidewalk areas as applicable.
- Sod should be considered in areas of concentrated runoff, i.e. bottom of vertical curves, inside areas of superelevated curves, tangent sections, and outside of curves. Refer to **Standard Plans, Index 570-001** for sodding requirements.
- Refer to **Standard Plans, Index 570-010** for milling and resurfacing projects or major projects with portions of milling and resurfacing.

210.7 Border Width

Commentary on Update: Removed "and greater" from bulleted list on 1/13/2020

Date of presentation: 11/4/2019 per Bobby Bull

- 210.8.1 – Deflections in Alignment

210.8.1 Deflections in Alignment^I

The point where tangents intersect is known as the PI. Avoid the use of a PI with no horizontal curve; however, there may be conditions where it is necessary (e.g., closely-spaced intersections in areas with limited R/W). The maximum deflection without a horizontal curve are as follows:

- Flush shoulder and curbed roadways with design speed 40 mph and less is 2°00'00".
- Flush shoulder roadways with design speed 45 mph and greater is 0°45'00".
- Curbed roadways with design speed of 45 mph ~~and greater~~ is 1°00'00".
- High speed curbed roadways with design speed 50 mph and greater is 0°45'00".

Commentary on Update: Changed “certified” language to remain consistent on 2/12/2020

Date of presentation: 2/3/2020 via email per Adam Scurlock

- Table 210.8.2 Condition #1 – Minimum Radius for Evaluation of Existing Horizontal Curves

Table 210.8.2 Minimum Radius for Evaluation of Existing Horizontal Curves

Maximum Superelevation (e_{max})		Minimum Radius (feet)									
		Design Speed (mph)									
		25	30	35	40	45	50	55	60	65	70
0.10	SHS	160	231	323	432	559	694	881	1091	1348	1637
	RRR	120	188	276	388	521	674	849	1042	1273	1528
0.05	SHS	194	286	402	533	694	881	N/A	N/A	N/A	N/A
	RRR	140	223	332	468	637	849	N/A	N/A	N/A	N/A

Condition #1 – A horizontal curve that meets or exceeds the SHS minimum radius shown in **Table 210.8.2** is satisfactory unless there is a significant crash history (3 or more crashes within the most recent available ~~certified-completely processed~~-5-year location verified data) or other evidence of safety or operational problems. If problems are identified, include corrective measures in the project.

Commentary on Update: Changed made to clarify that the M_r must be reduced for clearances less than 3ft. on 2/3/2020

Date of presentation: 11/7/20 via FDM Comment email per Quangchau Le

- 210.10.3 – Vertical Clearances

210.10.3 Vertical Clearances

Consider the following vertical clearance requirements when developing the vertical alignment:

- (1) Minimum clearances for bridge structures is given in **FDM 260.6**.
- (2) Minimum clearance from the bottom of the roadway base course to the Base Clearance Water Elevation is 3 feet, except as noted below. ~~A clearance less than 3 feet~~ **These exceptions will** requires a reduction in the design resilient modulus in accordance with the **Flexible Pavement Design Manual**. Coordinate with the Pavement Design Engineer for the following facilities:
 - (a) 2-lane roadways in context classification C1, C2, C2T and C3, and all ramps may be reduced to a 2-foot clearance.
 - (b) Low point on ramps at cross roads may be reduced to a 1-foot clearance.
 - (c) All other facilities in context classifications C4 through C6 may be reduced to a 1-foot clearance.

FDM 211 (Limited Access Facilities)

Commentary on Update: On 9/3/2020 by Gevin McDaniel.

Date of presentation:

- 211.1 – General

211.1 General

This chapter includes criteria for Limited Access (LA) Facilities (tolled and non-tolled), including:

- (1) Interstates
- (2) Freeways
- (3) Expressways
- (4) Interchange ramps servicing high speed LA Facilities
- (5) Collector-distributor roads (C-D) servicing high speed LA Facilities

Express-Managed lanes design is an iterative process best performed in a collaborative environment involving various disciplines e.g. **express-managed** lanes planning, PD&E, construction, maintenance, traffic operations, transportation systems management and operations (TSM&O). Involvement Coordinate with the Turnpike Toll Systems and Tolls Design Offices in Phase 14 of the design process for express lanes design and Turnpike toll operations.

Many design criteria are related to design speed; e.g., vertical and horizontal geometry, sight distance. When the minimum design values are not met, an approved Design Exception or Design Variation is required. See **FDM 201.5** for information on Design Speed. See **FDM 122** for information on Design Exceptions and Design Variations.

The following manuals and documents provide additional information for the design of LA Facilities:

- **General Tolling Requirements (GTR)** - ~~This document is used~~ Use this document for design criteria and requirements for tolling on Turnpike and Non-Turnpike projects. ~~This includes "open road" tolling facilities, express managed lanes (managed express lanes, high occupancy tolling lanes, etc.) on new or existing corridors.~~
- **AASHTO's A Policy on Geometric Design of Highways and Streets (AASHTO Green Book)**
- **A Policy on Design Standards – Interstate System, 2005 Edition (AASHTO)**
- **Turnpike Design Handbook (TDH)**

Specific requirements for ~~placement of the toll site infrastructure~~ toll site design (e.g., toll siting, toll facility demolition/renovation, toll facility site, toll facility building, and ing equipment structures, equipment buildings, utilities toll facility gantry) ~~are~~ is given in the General Tolling Requirements (**GTR**). ¶

Commentary on Update: This came from a DRDE topic asking for clarification on the FDM's intent on auxiliary lane cross slope. Added language to support auxiliary lane cross slope matching adjacent travel lanes.

Date of presentation: 4/9/2020 DRDE meeting.

- 211.2.2 – Pavement Cross Slopes

Topic #625-000-002
FDOT Design Manual

211.2.2 Pavement Cross Slopes

For roadways, the maximum number of travel lanes with cross slope in one direction is three lanes except as shown in **Figure 211.2.1**, which prescribes standard pavement cross slopes. A Design Variation or a Design Exception is required when proposed pavement cross slopes do not meet the requirements shown in **Figure 211.2.1**.

Outside auxiliary lane cross slopes must match or exceed adjacent travel lane cross slope. The auxiliary lane cross slope cannot exceed the values in **Figure 211.2.1**. In superelevation transitions, do not exceed the maximum algebraic differences shown in **Table 211.2.2**.

The maximum algebraic difference in cross slope between adjacent through lanes is 0.04. The maximum algebraic difference in cross slope between a through lane and an auxiliary lane at a turning roadway terminal is given in **Table 211.2.2**.

Cross slopes on bridges are to be on a uniform, straight-line rate, typically 0.02 (See **FDM 260.4**). Use transitions to adjust for differences in cross slope between the approach roadway section and the required straight-line slope for bridge decks. Whenever possible the transition should be accomplished on the roadway section, outside the limits of the bridge and approach slabs. This will require detailing of the transition(s) in the roadway plans. Coordination between the Roadway, Drainage and Structures designers in the development of transitions is required to ensure compatibility and harmonizing at bridge approaches.

- Table 211.2.3 Allowable Range for Existing Pavement Cross Slopes

Topic #625-000-002
FDOT Design Manual

Table 211.2.3 Allowable Range for Existing Pavement Cross Slopes

Facility or Feature	Standard (ft./ft.)	Allowable Range (ft./ft.)
Travel Lanes	0.02	0.015 - 0.025
Travel Lanes	0.03	0.025 - 0.035
Outside Shoulder	0.06	Adjacent Lane Cross Slope - 0.080
Median (left) Shoulder	0.05	0.020 - 0.080

Notes:

- (1) Standard cross slope (0.02 or 0.03) as designated in **Figure 211.2.1**.
- (2) The algebraic difference in cross slope between adjacent travel lanes must not exceed 0.04. The maximum algebraic difference in cross slope between a through lane and an auxiliary lane at a turning roadway terminal must meet **Table 211.2.2**.
- (3) When existing shoulders are to remain, the algebraic difference between the shoulder slope and adjoining roadway pavement slope must be ≤ 0.07 .
- (4) Outside auxiliary lanes must match or exceed adjacent travel lane cross slopes with a maximum cross slope of 0.035.

Commentary on Update: On 9/3/2020 by Gevin McDaniel

Date of presentation:

- 211.3 – Express Lanes Separation

Facilities that have the ability to be expanded for additional capacity in the future will be designed to accommodate that future expansion. For example, a 4-lane high-speed facility that has the potential to expand to a 6-lane facility (without **express-managed** lanes) may be designed with a 50-foot median with barrier (e.g. guardrail, high tension cable barrier) instead of the required 60-foot median. A 50-foot median will accommodate a future 2-foot concrete median barrier, two 12-foot travel lanes and two 12-foot shoulders.

211.3.1 Bridge Median

Commentary on Update: On 5/26/2020 by Gevin McDaniel

Date of presentation:

- 211.3.3 – Express Lanes Separation

211.3.3 ~~Express Lanes~~ ~~Managed Lanes~~ Separation

~~Express lanes~~ ~~Managed lanes~~ are always separated from the general use lanes or general toll lanes. Median openings and crossovers are prohibited within ~~managed~~ ~~express~~ lanes.

There are four types of ~~express~~ ~~managed~~ lanes separation treatments:

- (1) Barrier separation; see **Figure 211.3.1**
- (2) Buffer separation with ~~express lanes~~ ~~tubular~~ markers; see **Figure 211.3.2**
- (3) Wide buffer separation; see **Figure 211.3.3**
- (4) Grade separation; see **Figure 211.3.4**

The minimum standard buffer width for the buffer separation is 4 feet. Any variation from a 4-foot-buffer width must be approved by the District Design Engineer. Install ~~express~~ ~~lane~~ ~~tubular~~ markers per the **TEM**, ~~Section 4.2~~ ~~Chapter 4~~. Use barrier separation or grade separation when implementing a reversible ~~express~~ ~~managed~~ lane system.

The maximum spacing and placement of ~~express lanes~~ ~~tubular~~ markers is provided in the **TEM**. If, based on operational and safety analysis, the EOR or the district wishes to increase the maximum allowable spacing, a Design Variation must be approved by the Chief Engineer.

Figure-211.3.1 → **Express-Managed-Lanes-Barrier-Separation-Typical-Section**

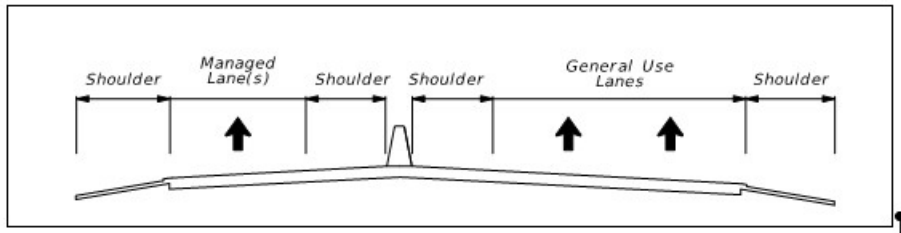

Figure-211.3.2 → **Express-Managed-Lanes-Buffer-Separation-with-Express-Lanes Tubular-Marker-Typical-Section**

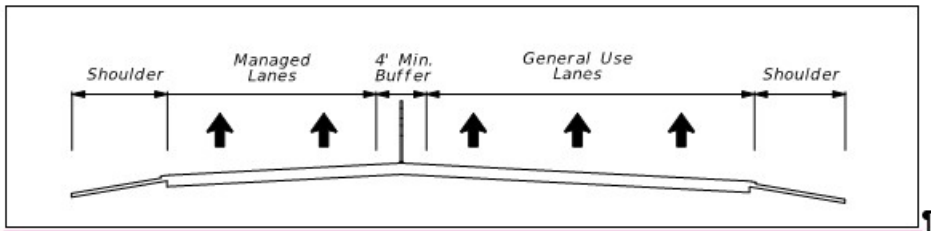
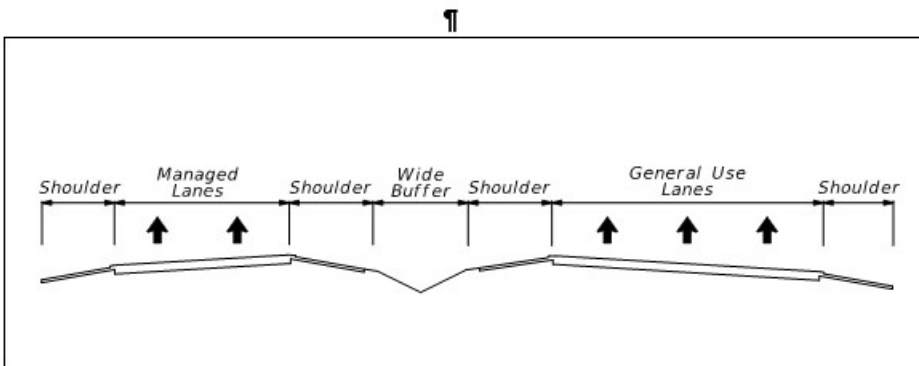
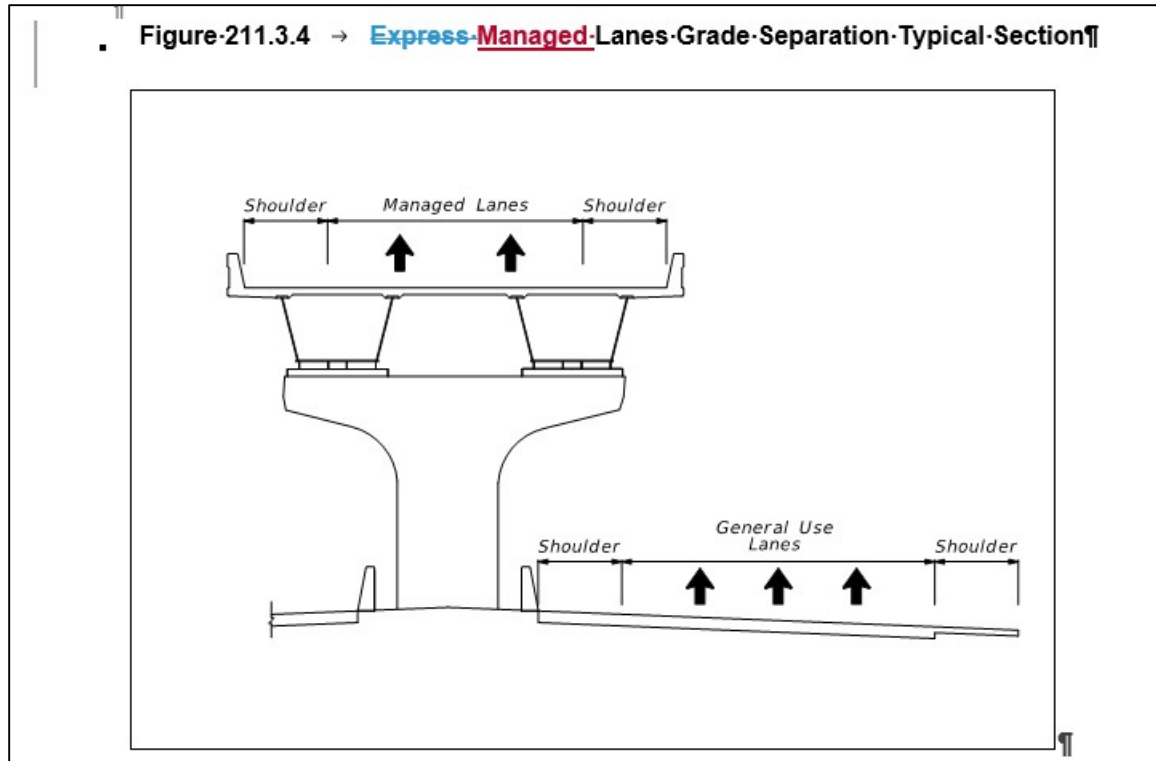

Figure-211.3.3 → **Express-Managed-Lanes-Wide-Buffer-Separation-Typical-Section**





Commentary on Update: On 7/8/2020 by Bobby Bull- Language moved from the FDM Drainage Design Manual

Date of presentation:

- 211.4 – Shoulders

211.4 Shoulders

Roadway shoulder width is measured from the edge of the traveled way to the shoulder break. A portion of the shoulder is required to be paved. Required shoulder widths and paved widths are given in **Table 211.4.1**.

Use shoulder gutter for the following conditions:

- On embankments higher than 20 feet
- On embankments higher than 10 feet where the longitudinal slope is greater than 2 percent
- On embankments, with slopes steeper than 1:6 for more than five feet vertically, to minimize erosion
- At bridge ends where concentrated flow from the bridge deck otherwise would run down the slope
- In areas of guardrail where embankment slopes are steeper than 1:4 and any pavement is sloped toward the embankment.

Refer to **FDM 260.3** for bridge shoulder widths.

See **General Tolling Requirements (GTR)** for **required** paved shoulder **width design requirements** at tolling locations.

Commentary on Update: On 9/3/2020 by Gevin McDaniel

Date of presentation:

- 211.4.1 – Managed Lanes Shoulders

<p>211.4.1 Express <u>Managed</u> Lanes Shoulders</p> <p>The required width for <u>express-managed</u> lanes shoulders depends on the type of separation between the <u>managed</u><u>express</u> lanes and the general use lanes or general toll lanes. When retrofitting <u>managed</u><u>express</u> lanes in constrained conditions, shoulder widths in Table 211.4.1 may not be achievable without a Design Variation or Design Exception. Consult the <u>Highway Safety Manual</u> on safety tradeoffs when narrowing shoulder widths.</p>
--

Commentary on Update: On 8/28/2020 by Benjamin Gerrell.

Date of presentation:

- Table 211.4.1 – Minimum Shoulder Widths

Table 211.4.1 Minimum Shoulder Widths									
Minimum Shoulder Width (ft.)									
Lane Type	# Lanes (One Direction)	Without Shoulder Gutter				With Shoulder Gutter			
		Outside or Right		Median Or Left On Divided Roadways		Outside or Right		Median Or Left On Divided Roadways	
		Full Width	Paved Width	Full Width	Paved Width	Full Width	Paved Width	Full Width	Paved Width
Travel Lanes	2-Lane	12	10	8	4	15.5	8	13.5	6
	3-Lane or more	12	10	12	10	15.5	8	15.5	8
Express <u>Managed</u> Lanes	1-Lane	12	12	12	12	13 17.5	10	13 17.5	10
	2-Lane	12	12	12	12	13 17.5	10	13 17.5	10
Ramps	1-Lane Ramp	6	4	6	2	11.5	4	11.5	4
	2-Lane Ramp Non-Interstate	10	8	8	4	15.5	8	13.5	6
	2-Lane Ramp Interstate	12	10	8	4	15.5	8	13.5	6
C-D Roads	1-Lane	6	4	6	2	11.5	4	11.5	4
	2-Lane	12	10	8	4	15.5	8	13.5	6
	3-Lane or more	12	10	12	10	15.5	8	15.5	8
Aux. Lanes	ALL	12	10	8	4	15.5	8	8 11.5	4

Commentary on Update: Comment provided by James Beverly

Date of presentation:

- 211.4.4.1 Ground-in Rumble Strips

Exclude ground-in rumble strips at the following locations:

- (1) On bridges, terminate at the approach slab joint.
- (2) On approach to mainline toll plazas, terminate at the end of the mainline normal section.
- (3) On All Electronic Tolling (AET) facilities within the tolling area as defined in Appendix 17 of the **General Tolling Requirements (GTR)**.
- (4) On outside shoulders of entrance ramp terminals, terminate at the point of the physical gore and resume at the end of the acceleration lane taper.
- (5) On outside shoulders of exit ramp terminals, terminate at the start of the deceleration lane taper, and resume at the point of the physical gore.
- (6) On either side of median crossover openings, terminate within 400 feet.

Commentary on Update: Comment provided by James Beverly

Date of presentation:

- 211.4.5 Emergency Refuge Areas

<p>211.4.5 → Emergency Refuge Areas¶</p> <p>Consider including Emergency Refuge Areas (ERAs) in areas where additional shoulder widths are deemed necessary (e.g., law enforcement, vehicle refuge). Coordinate with Traffic Operations, Maintenance, and Law Enforcement to determine if ERAs would be appropriate for the roadway facility. ¶</p> <p>For <u>managed express</u> lanes projects, consider ERAs where deemed necessary in coordination with Traffic Engineering and Operations, Maintenance, and Law Enforcement, and Toll Operations. <u>Include Coordinate with the Turnpike Toll Systems and Tolls Design Offices for express lanes projects during Phase I of the design process.</u> For <u>managed express</u> lanes in constrained conditions, a staggered shoulder may be designed to allow storage of disabled or damaged vehicles. ¶</p>
--

Commentary on Update: On 7/30/2020 by Bobby Bull- Language moved from FDM 215

Date of presentation:

- 211.5 – Roadside Slopes

211.5 Roadside Slopes

Side slopes within the clear zone are typically 1:6 or flatter. When site conditions require the use of steeper slopes, refer to new construction criteria included in **FDM 215**.

The following guidance is being provided to designers for consideration during project design. Additional sod requirements are provided in the **FDOT Drainage Design Manual** and in the **Standard Plans, Indexes 570-001** and **571-010**.

- Sod should be considered for slopes 1:4 or steeper. For all other areas, refer to **FDOT Drainage Design Manual**, Chapter 2, Table 2.5, for additional guidance on maximum velocity for each lining type.
- Sod should be used for projects with less than 10,000 square feet of disturbed area.
- Sod should be considered for narrow areas less than six feet.
- A minimum 48" of sod should be considered for back of sidewalk areas as applicable.
- Sod should be considered in areas of concentrated runoff, i.e. bottom of vertical curves, inside areas of superelevated curves, tangent sections, and outside of curves. Refer to **Standard Plans, Index 570-001** for sodding requirements.
- Refer to **Standard Plans, Index 570-010** for milling and resurfacing projects or major projects with portions of milling and resurfacing.

Commentary on Update: On 9/3/2020 by Gevin McDaniel

Date of presentation:

- 211.10.2 – Decision Sight Distance

¶ The geometric design developed for LA Facilities considers locations where decision sight distance is critical such as interchanges, toll plazas facilities, lane drops, and managed express lanes ingress/egress locations. Decision sight distance requirements are in **AASHTO Green Book, Section 3.2.3**. If it is not practical to provide decision sight distance at these locations, or if relocation of the critical decision points is not feasible, special attention will be given to the use of suitable traffic control devices for providing advance warning of the sub-standard condition. ¶

Do not place managed express lane ingress or egress within the limits of a Design Variation or Design Exception processed for sight distance. ¶

- 211.12.1.1 – Braided Ramps

When combining general use lane or general toll lane exits and **managed express** lane exits in a braided ramp configuration, the **managed express** lane exit merges on the right side of the general use lanes or general toll lanes as illustrated in **Figure 211.12.3**. Operational analysis determines the actual lane configuration. Refer to **Traffic Analysis Handbook** and **Interchange Access Request User's Guide** for guidance on analysis requirements.

Figure-211.12.3-Braided-Express-Managed-Lane-and-General-Use-Lane-Exits

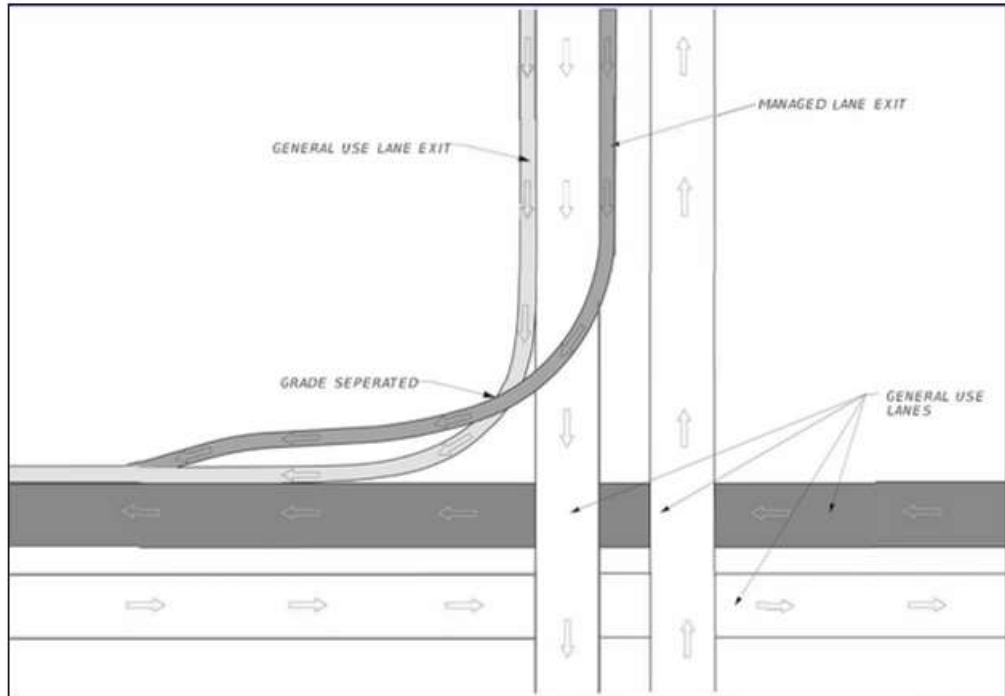

- 211.14 – Managed Lanes Access Points and Access Types

211.14 → **Express-Managed-Lanes-Access-Points-and-Access-Types**

The design of **managedexpress** lanes access points is based on major origin and destination patterns, the location of toll **pointsfacilities**, and the location of existing interchanges with the general use or general toll lanes. The operational analysis associated with **managedexpress** lanes access points is performed using the methodology in the Highway Capacity Manual and/or microsimulation. Refer to [Traffic Analysis Handbook](#) and [Interchange Access Request User's Guide](#) for guidance on analysis requirements.

Perform an operational analysis to determine the required length of the weave segment that will accommodate the weave demand. Base the analysis on 1000 feet per lane change weaving length (See **Exhibits 211-3 to 211-6**). Adjust the weave segment length as needed based on the analysis. Perform a safety analysis as required in the [Interchange Access Request User's Guide](#).

An access point serves one of three uses:

- (1) → Point of entry to the **managedexpress** lanes
- (2) → Intermediate point of entry/ingress or exit/egress

¶
211-Limited-Access-Facilities¶

- (3) → Termination of **managedexpress** lanes

When determining the point of entry and the termination of **managedexpress** lanes, consideration is given to future phased implementation plans for the corridor depicted in the ultimate **managedexpress** lanes diagram. Avoid temporary access points.

Avoid locating an **managedexpress** lanes access point in the same weaving area as other highway weaving movements; interchange on-ramps, interchange off-ramps, or auxiliary lanes. Access points are located to provide the required weave length between the **managedexpress** lanes and general use lanes or general toll lanes. If placed closer than the required minimum weave length, additional traffic control devices are added to prohibit vehicles from cutting across traffic to get into the **managedexpress** lane or get out to the interchange exit.

Traffic operational analyses must demonstrate that queuing from vehicles exiting the **managedexpress** lanes to the general use lanes or general toll lanes will not encroach on the **managedexpress** lanes.

Refer to **Section 2.42** of the [TEM](#) for guidelines on **managedexpress** lanes entrance/ingress and exit/egress signs and signing sequence.

- 211.14.1 – Managed Lanes Access Types yes

211.14.1 → ~~Express-Managed-Lanes-Access-Types~~

On Florida's ~~managed~~~~express~~ lanes, the following types of access are used:

- → Slip Ramps
- → Weave Lanes
- → Weave Zones
- → Direct Connect

Slip ramps, weave lanes, and weave zones on the Interstate do not require an interchange access request. A weave lane or weave zone is used in constrained conditions for intermediate ingress and egress points and requires approval of the District Design Engineer.

Direct connect ramps (~~Express Exits~~) are used for system-to-system connection between ~~managed~~~~express~~ lanes facilities, toll facilities, major arterials, park-and-ride facilities, and transit facilities. ~~Express Exits~~ **Direct connect ramps** on the Interstate require an interchange access request (Refer to the [Interchange Access Request User's Guide](#)).

FDM 212 (Intersections)

Commentary on Update: On 5/8/2020 by Gevin McDaniel

Date of presentation:

- 212.1 – General

See **FDM 210** for lane width, median width, islands dimensions, and deflection angle requirements.

Commentary on Update: On 3/31/2020 by James McGinnis

Date of presentation:

- 212.2.1 – Yield Control

212.2.1 Yield Control

Certain channelized movements at intersections and interchanges, and all approaches to roundabouts are often yield controlled. Refer to the ***Manual on Uniform Traffic Control Devices (MUTCD)*** for information on the locations where yield control traffic control devices may be appropriate.

Commentary on Update: On 5/8/2020 by Gevin McDaniel

Date of presentation:

- 212.3 – Intersection Types

212.3 Intersection Types

Conventional intersection configurations include flared and channelized intersections (divided and undivided). Flared intersections are illustrated in **Figure 212.3.1** and channelized intersections in **Figure 212.3.2**. See **FDM 210.3** for median and island requirements.

Commentary on Update: On 5/21/2020 by Gevin McDaniel

Date of presentation:

- 212.12.1 – Edge-of-Traveled-Way Design

- (5) Curb radii should be coordinated with crosswalk distances or special designs should be used to make crosswalks efficient for all pedestrians. Where larger radii are used, an intermediate refuge or median island is desirable or crosswalks may need to be offset so that crosswalk distances are not excessive. See **FDM 210.3** for additional information on islands.

Commentary on Update: On 8/11/2020 by Benjamin Gerrell

Date of presentation:

- 212.12.2 – Turning Roadways with Corner Islands

212.12.2 → Turning Roadways with Corner Islands

Consider providing a corner island at an intersection where paved areas are excessively large or do not establish proper channelization of traffic. Corner islands can provide delineation for through and turning traffic. In addition to channelization for motor vehicles, corner islands shorten crosswalks and give pedestrians and bicyclists a refuge area. See **FDM-210.3.2** for island requirements.

Channelized right-turn lanes can be designed with a flat or near-perpendicular angle of entry to the cross street (see **Figure 212.12.2**). The flat angle of entry is most appropriate for higher speed turning movements with no pedestrian accommodations. Large turning radii and angles of entry into the cross street allow higher turning speeds, reduced traffic delays, and the turning movement of large trucks. The higher speeds, angle of entry and large radii adversely impacts pedestrian safety at the crosswalk.

The near-perpendicular angle of entry is preferred where pedestrian facilities are provided. Tight turning radii and angles of entry into the cross street accommodate the following:

- → Slower turning speeds.
- → Reduced cross-walk length.
- → Improved pedestrian visibility.
- → Improved sight distance.
- → Decreased angle of driver head turning.
- → Reduced right-of-way impacts.

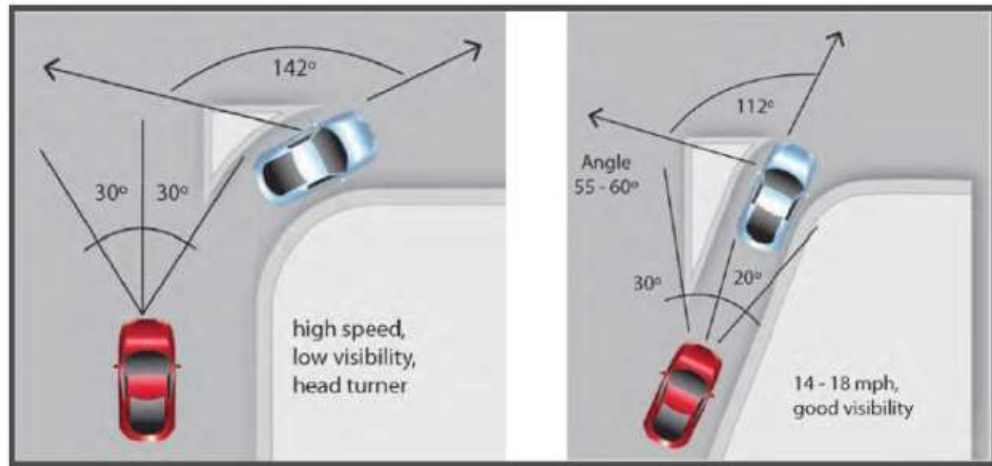
Figure-212.12.2-Channelized-Right-Turn-Lanes

Ref: Figure 9-19, 2018 AASHTO Green Book

Consider the near-perpendicular right-turn lane design in **Figure 212.12.3** when the following conditions are met:

- → Context Classification C2T, C3, C4, C5 and C6
- → Low-speed roadway (design speeds 45 mph and less)
- → Pedestrian traffic is expected
- → No acceleration lane is provided

This design includes the previously mentioned benefits to passenger cars and pedestrians with striping and a scalene triangle-shaped corner island. An approaching deceleration lane is preferred to provide give vehicles additional time to stop for crossing pedestrians. The crosswalk is set back at a 20-foot minimum from the end of the island to allow room for a passenger car to wait for a gap in traffic without blocking the crosswalk. As shown in **Figure 212.12.3**, the outside curb radii can be designed to accommodate overtracking of large vehicles such as single-unit trucks, transit, or Florida Interstate Semi-trailers (WB-62FL).

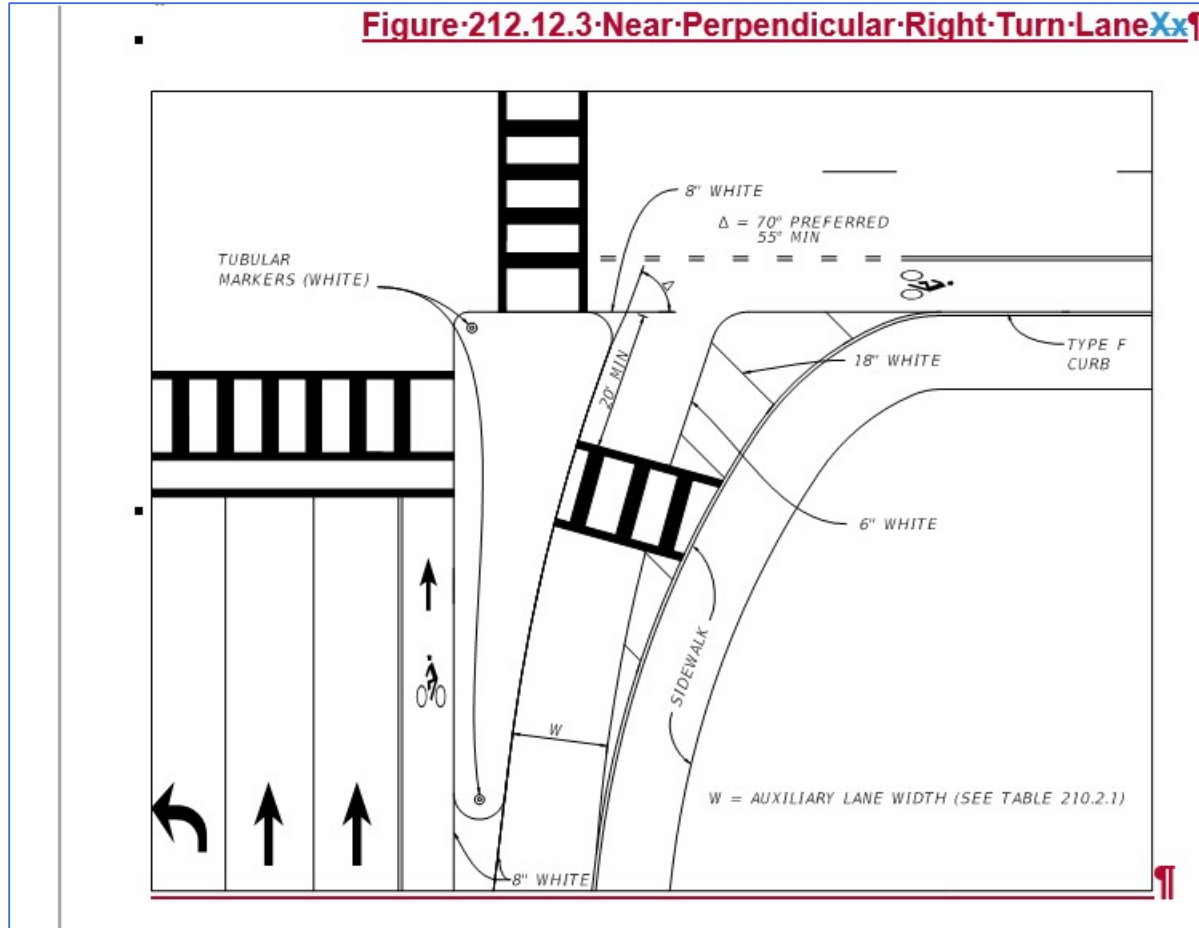
Figure 212.12.3 Near-Perpendicular Right-Turn Lane

Commentary on Update: On 8/11/2020 by Benjamin Gerrell

Date of presentation:

- 212.12.4 – Dual and Triple Left Turns

212.12.34 Dual and Triple Left Turns

Double and triple turn lanes require turning radii that will accommodate the selected design vehicles turning simultaneously. The radius of curvature in combination with the track width of the design vehicles will establish the required width within the turn. Lane lines (i.e., guide lines) and width requirements should be determined by plotting the swept paths of the selected design vehicles. For preliminary layout of intersection geometry, use the swept path of the design vehicle on the inside turning lane to locate the median nose and crosswalk on the crossing street (at the receiving point of the left turn).

Design of dual turns should accommodate a SU-40 vehicle and a P vehicle turning simultaneously, as illustrated in **Figure 212.12.24**.

Commentary on Update: Removed entire 212.13 Islands section on 5/7/2020 by Gevin McDaniel

Date of presentation:

- 212.13 – Islands

<p>212.13 Islands</p> <p>See FDM 210.3 for island criteria. An island is an area between traffic lanes that provide one or more of these primary functions:</p> <p>(1) Channelization — to control and direct traffic movement (usually turning).</p>
--

Commentary on Update: On 5/11/2020 by Gevin McDaniel

Date of presentation:

- 212.14.5 – Directional Median Openings

<p>The design of a directional median opening must accommodate the swept path of the predominant design vehicle. Channelization may be achieved using a combination of traffic separators, raised islands, or and high performance traffic delineators tubular markers. See FDM 210 for more additional information on islands. See Standard Plans, Index 520-020 for standard details for 4 feet, 6 feet and 8.5 feet wide traffic separators. See FDM 230.2.7 for additional information on high performance delineators tubular markers.</p>
--

FDM 213 (Modern Roundabouts)

Commentary on Update: Added on 8/14/2020 by Bobby Bull

Date of presentation: On 4/27/2020 by email per Juan Canizares

- 213.3 – Geometric Design

<p>(3) Geometric features (e.g., inscribed circle diameter (ICD), lane width, entry width, curb locations) introduce deflection and curvature into the driver's path and is the most effective way to slow vehicles down to a safe entry speed.</p> <p>Typical ranges are as follows:</p> <p>Single-lane Roundabout ICD: 120' to 160' with 140' as a good starting point</p> <p>Two-lane Roundabout ICD: 160' to 200' with 180' as a good starting point</p>
--

Commentary on Update: This update was to have consistency in wording within 213. The language was updated to say "less than 75 degrees".

Date of presentation: N/A

- 213.3.3 - Angle Between Approach Legs

213.3.3 Angle Between Approach Legs

The intersection angle between two roadways has a significant influence on the geometrics and operation of a roundabout. Intersection angles are to be as close to 90 degrees as practical. Consider realigning the approach legs of minor roads when the intersection angle is ~~less~~greater than 75 degrees; **Figure 213.3.1** illustrates realignment configurations.

Commentary on Update: On 5/26/2020 by Gevin McDaniel

Date of presentation:

- 213.3.5 - Splitter Islands

Locate the crosswalk approximately 20-feet upstream from the yield line. Minimum width for the raised splitter island at crosswalks is 6-foot (between curb faces). The minimum crosswalk width in the splitter island is 10-feet. These dimensions ensure the provision of a pedestrian refuge area within the splitter island. ~~Locate the crosswalk approximately 20 feet upstream from the yield line.~~

Commentary on Update: On 5/26/2020 by Gevin McDaniel

Date of presentation:

- 213.8.1 Pedestrian Facilities

(c) Provide a pedestrian refuge area within the splitter island meeting the requirements of **FDM 213.3.5** ~~At each crosswalk location provide a minimum 6-foot wide and 10-foot long pedestrian refuge area within the splitter island. Locate the pedestrian refuge area approximately 20 feet from the outside edge of the circulatory roadway.~~

FDM 214 (Driveways)

Commentary on Update: On 5/8/2020 by Gevin McDaniel.

Date of presentation:

- Table 214.3.1 – Driveway Dimensions

	Connection Spacing	201.4.3
<p>Notes:</p> <ol style="list-style-type: none"> 1. Connection Categories A, B, C, and D are defined in FDM 214.1.1. 2. 2-Way refers to one entry movement and one exit <u>movement</u>; i.e., not exclusive left or right turn lanes on the connection. 3. Small radii may be used in lieu of flares for curbed roadways in Connection Category B when approved by the Department. 4. The Angle of Driveway for Connection Category A may be reduced with approval by the local Operations/Maintenance Engineer. 5. Design criteria for channelization islands (I) is found in FDM 2120.13. <p>Radial Returns (Radius):</p> <ol style="list-style-type: none"> 6. Provide the minimum radius for low-speed roadways with driveway design vehicle of a passenger car. 7. Provide the standard radius for high-speed roadways or driveway with large design vehicles (e.g., SU-30). 8. Consider providing the maximum radius or compound curve for high-speed roadways or driveway with large design vehicle (e.g., WB-62). 		

Commentary on Update: On 5/8/2020 by Gevin McDaniel.

Date of presentation:

- 214.3.4 – Driveway Traffic Separator and Channelization Island

<p>214.3.4 Driveway Traffic Separator and Channelization Island</p> <p>Width requirements for driveway traffic separators are provided in Table 214.3.1. For triangular channelization islands, see FDM 212210.13 for criteria and information.</p>
--

FDM 215 (Roadside Safety)

Commentary on Update: Removed “to the maximum extent feasible” on 4/13/2020

Date of presentation: 4/13/2020 via email per Benjamin Gerrell

- 215.1.1 – RRR Criteria

215.1.1 RRR Criteria

Criteria for RRR projects provided in this chapter are the minimum values allowed for roadside elements to remain on arterials and collectors without obtaining a Design Exception or Design Variation (see **FDM 122**)...

Criteria for RRR projects provided in this chapter may be used for establishing the minimum requirements for adding auxiliary lanes, keyhole lanes, or providing minor intersection improvements with the understanding that when existing right of way (R/W) is adequate, new construction criteria will be used ~~to the maximum extent feasible~~.

Do not apply RRR criteria in this chapter to resurfacing projects on Limited Access (LA) Facilities.

Commentary on Update: On 7/28/2020 by Richard Stepp

Date of presentation:

- 215.2.2 – Roadside Slope Classification

215.2.2 Roadside Slope Classification

Roadside Slopes include areas located beyond the edge of the traffic lane as shown in **Figures 215.2.2** and **215.2.3**. These areas are divided into the following classifications:

- (1) Traversable Slope – Smooth terrain, unobstructed by fixed objects:
 - (a) Recoverable Traversable Slope, 1:4 or flatter
 - (b) Non-Recoverable Traversable Slope, ~~1:3 or flatter and steeper than 1:4 and flatter than 1:3~~
- (2) Non-Traversable Slope – Rough terrain, obstructed, or slopes steeper than 1:3

Commentary on Update: On 7/9/2020 by Bobby Bull and Ben Gerrell.

Date of presentation:

- Table 215.2.2 – Minimum Lateral Offset Criteria

Table 215.2.2 → Minimum Lateral Offset Criteria						
Design Element		Curbed Roadways				High-Speed Curbed and Flush Shoulder Roadway
		New Construction		RRR		
		Design Speed				
		25-35 mph	40-45 mph	25-35 mph	40-45 mph	
Light Poles	Conventional	Do not locate in Medians, except in conjunction with barriers that are justified for other reasons. See <i>FDM 215.2.9</i> .				
		1.5 feet	4.0 feet	1.5 feet	1.5 feet	20 feet from Travel Lane, 14 feet from Auxiliary Lane, or Clear Zone width, whichever is less
	High Mast	Outside Clear Zone				
Signal Poles and Controller Cabinets		Do not locate in Medians, except for PHB or overhead RRFB in accordance with See <i>FDM 215.2.9</i> .				
		1.5 feet	4.0 feet	1.5 feet	1.5 feet	Outside Clear Zone
Traffic Infraction Detectors		For placement and installation specifications, refer to the State Traffic Engineering and Operations Office web page: http://www.fdot.gov/traffic				
ITS Poles and Related Items	Pole & Other Aboveground Fixed Objects	Do not locate in Medians, except in conjunction with barriers that are justified for other reasons. See <i>FDM 215.2.9</i> .				
		1.5 feet	4.0 feet	1.5 feet	4.0 feet	Outside Clear Zone
	Equipment Shelters and Towers	Do not locate within the limited access right-of-way, except as allowed by Policy No. 000-625-025, Telecommunications Facilities on Limited Access Rights-of-Way.				
	Breakaway Objects	1.5 feet	4.0 feet	1.5 feet	4.0 feet	As Close to R/W As Possible
Traffic Control Signs	Single and Multi-Column	Locate in accordance with Standard Plans.				
	Overhead Sign Structures (Includes DMS)	Outside Clear Zone				
Trees	Where the diameter is or is expected to be > 4 inches measured 6 inches above the ground	1.5 feet	4.0 feet	1.5 feet	1.5 feet	Outside Clear Zone
		RRR Projects: (1) Meet New Construction criteria for new plantings.				

Commentary on Update: On 7/2/2020 by Bobby Bull- Language moved to 210 and 211

Date of presentation:

- 215.2.6 – Roadside Slope Criteria

215.2.6 Roadside Slope Criteria

Roadside slopes consist of front slopes, back slopes, and transverse slopes. Roadside slope criteria is provided in **Table 215.2.3**.

~~For sod or turf slopes steeper than 1:3:~~

- ~~• Consider the associated long term erosion control and maintenance costs.~~
- ~~• Slopes higher than 20 feet, provide a 10-foot wide maintenance berm (1:10 or flatter) at the top and toe.~~
- ~~• Slopes higher than 35 feet, provide a 10-foot wide maintenance berm (1:10 or flatter) at the top and toe. Include intermediate berm(s) so that the spacing between berms does not exceed 35 feet. Coordinate with the District Drainage, Maintenance, and Landscape Architect's Offices.~~

Coordinate with the District Geotechnical Office for slopes steeper than 1:2.

Commentary on Update: On 7/28/2020 by Richard Stepp.

Date of presentation:

- Table 215.2.3 – Roadside Slope Criteria

Type of Slope	Flush Shoulder and High Speed Curbed		Curbed	
	Height of Fill (feet)	Rate	Height of Fill (feet)	Rate
Front Slope	0 – 5	1:6	≤ 6	1:2 or to suit property owner, not flatter than 1:6.
	5 – 10	1:6 to edge of Clear Zone, then 1:4	≥ 6	1:3 or to suit property owner, not flatter than 1:6.
	10 – 20	1:6 to edge of Clear Zone, then 1:3		
	> 20	1:2 with guardrail		
Back Slope	All	1:4 or 1:3 with a standard width trapezoidal ditch and 1:6 front slope	All	1:2 or to suit property owner. Not flatter than 1:6.
Transverse Slope	All	1:10 or flatter (freeway & Interstate)	All	1:4
		1:4 (others)		

Notes:
 (1) Height of fill is the vertical distance from the edge of the outside travel lane to the toe of front slope.

Commentary on Update: On 5/8/2020 by Gevin McDaniel.

Date of presentation:

- 215.2.7.2 – Curbs, Medians, and Islands

215.2.7.2 ~~Curbs, Medians, and Traffic Separators~~ **Islands**

See **FDM 210.5** for information concerning curbed roadways.

Curb has no redirection capability; therefore, do not use curb to mitigate clear zone violations. ~~The addition of Curb for the sole purpose of achieving Lateral Offset Criteria is prohibited.~~

~~Traffic separators are used to:~~

- ~~• provide delineation of narrow roadway medians~~
- ~~• manage access points and turning movements~~
- ~~• provide for drainage~~
- ~~• offer pedestrian refuge areas~~

Refer to the **FDM 210.13.2** and **Standard Plans, Index 520-020 (Traffic Separators)** for additional information concerning ~~traffic separators~~ **medians and islands**.

A bridge mounted traffic separator is to match geometrically with adjacent roadway traffic separator or the face of curb. Design separators in accordance with the **Structures Design Guidelines**, and **Standard Plans, Index 520-020**.

Shoulder Gutter is frequently used along roadway fill sections and bridge approaches to prevent excessive runoff down embankment slopes. Refer to the **FDM 210.4 and 211.4 Drainage Manual** for Shoulder Gutter requirements.

Commentary on Update: On 6/23/2020 by Gevin McDaniel.

Date of presentation:

- 215.2.9 – Signing, Lighting, Traffic Signals, Intelligent Transportation Systems (ITS), and Other Similar Roadside

~~Avoid placing~~ Light poles or ~~traffic~~ signals in the median ~~where, when struck,~~ may become a hazardous flying objects to vehicles in an opposing lane ~~when struck.~~ Do not place overhead sign structure (cantilever or truss) supports, conventional light poles, or ~~traffic signal~~ mast arm supports in the median, except in conjunction with barriers that are justified for other reasons. ~~Avoid placing s.~~ See **FDM 231.1** for additional limitations on placing lighting in the median.¶

~~Overhead structural supports in the median for a Pedestrian Hybrid Beacon (PHB) or Rapid Rectangular Flashing Beacons (RRFBs) may be placed in the median at midblock crossings unless if it is not possible to place elsewhere. Place the supports near the center of the median to the greatest extent practicable, and while meeting the minimum lateral offsets in Table 215.2.2. See FDM 231.1 for additional limitations on placing lighting in the median.¶~~

Do not locate high mast lighting poles in gore areas within the runout length as defined in the **AASHTO RDG, Section 5.6.4.**¶

Commentary on Update: On 8/31/2020 by James McGinnis.

Date of presentation:

- 215.4.6.1 – Barrier Offset

For flush shoulder roadways, the standard offset for W-Beam Guardrail, measured from the Edge of Traveled Way to the face of guardrail, is the full shoulder width plus 2 feet, not to exceed 12 feet. The 12-foot offset limit for guardrail is established to reduce the potential for impacts where the vehicle is behaving significantly different than the crash tested conditions (i.e. non-tracking, fish-tailing, excessive approach angle, etc.). Guardrail offsets greater than 12 feet require site-specific justification in accordance with **FDM 215.4.7**, unless the condition is based on requirements of the Standard Plans, **FDM 215.4.6.4** for **Median Barrier**, ~~or FDM 215.3.2 for Canal Hazards,~~ ~~or Sshoulder Gutter segments.~~ For ~~Sshoulder Gutter~~ segments only, ~~Gguardrail may be placed with a 14-foot offset to accommodate a 12-foot useable shoulder width.~~

Commentary on Update: Removed “to the extent practical” on 4/13/2020

Date of presentation: 4/13/2020 via email per Benjamin Gerrell

- 215.4.6.4 – Continuous Median Barriers

In locations where a continuous median barrier is present, the length of a barrier opening should be minimized to the extent practical. As shown in **FDM Exhibit 211-3**, the barrier ends on each side of the opening should be offset. Provide crashworthy end treatments or crash cushions to shield the barrier ends when the ends are within the clear zone and fall within the departure angle used to set length of need. Provide crashworthy end treatments or crash cushions when the angle between barrier ends is less than 30 degrees, measured from the direction of mainline travel.

Commentary on Update: Changes made for accuracy on 1/16/2020

Date of presentation: 1/16/2020 via e-mail per Richard Stepp

- 215.4.6.5 – Requirements for Culverts

Topic #625-000-002
FDOT Design Manual

215.4.6.5 Requirements for Culverts

Roadside barriers placed at a culvert (i.e., box culvert, bridge culvert, or three-sided culvert) should be either W-Beam Guardrail or Bridge Traffic Railing. See **Chapter 6** of the [Structures Design Guidelines](#) for more information regarding bridge traffic railings.

W-Beam Guardrail is the preferred barrier option, provided the grading, post embedment and length of need requirements can be met. A minimum of 4 feet of fill must be provided over the culvert for adequate post embedment and performance. If there is less than 4 feet of fill over the culvert, utilize one of the following options:

- (1) Culverts with total overall widths ≤ 5 feet: use W-Beam Guardrail with a post layout that straddles the outside of the culvert using standard post spacing of 6'-3".
- (2) Culverts with total overall width between 5 feet and 20 feet: use shortened W-Beam guardrail posts (e.g., Encased Post for Shallow Mount). See [Standard Plans Design Standards Plans, Index 400536-001](#).
- (3) Culverts with total overall width > 20 feet: use a project specific designed metal traffic railing similar to the Thrie-Beam Retrofit barriers (i.e. thrie-beam railing attached directly to the culvert headwall), see the [Standard Plans, Index 460 Series](#). Designers should note that the locations of the first and last posts are critical. Headwalls must be a minimum of 18 inches wide and the base plate must be located so that it is located at least 12 inches away from any construction joint or free end of the concrete headwall.

Commentary on Update: On 2/11/2020 and 3/25/2020 By Gevin McDaniel.

Date of presentation:

- 215.4.6.6 – Temporary Barriers

The presence of barriers on both shoulders may eliminate any effective shoulder width or refuge area. The effective shoulder width is required to ensure an area is available for both disabled vehicles during normal traffic conditions and access for emergency responders during stopped conditions. Therefore, on interstate, freeway, and expressway projects requiring barriers on both sides of the work zone traveled way, provide a minimum 10-foot lateral offset from the edge of the traveled way to the barrier on at least one side of the roadway. Providing refuge to the outside Right-side offsets are preferred. For conditions with more than three lanes in one direction, provide Consider a 10-foot lateral offset on both sides of the roadway for roadways more than 3 lanes in one direction. See also, **FDM 211.4.6** for Emergency Shoulder Use (ESU) requirements. Existing bridges and grade-separated approaches that are not along an ESU evacuation route need not be widened to meet this requirement. Bridge construction and associated roadway approaches are exempt from this requirement. Consider providing this 10-foot lateral offset on arterials and collectors should be considered. For all other applications, provide the minimum lateral offset required per Standard Plans, Index 102-100.

Commentary on Update: On 6/11/2020 by Derwood Sheppard.

Date of presentation:

- 215.5.3 – Temporary Attachments to Barriers

215.5.3 Temporary Attachments to Barriers

Standard Plans, Index 700-012 or Index 700-013 may be used for temporary work zone signs when the application of Standard Plans, Index 102-600 cannot be achieved. Use Standard Plans, Index 700-012 only when mounting to the top of the barrier/railing places the sign panel closer than 2 feet from the traveled way.

Commentary on Update: On 7/9/2020 Incorporated by SDB 20-04, Class 5 Coating Approval Process

Date of presentation:

- 215.6 – Surface Finishes

215.6 Surface Finishes

~~Class 5 coatings, tints or stains may be applied to roadway concrete barrier walls in order to be compatible with the treatment of bridge or retaining wall mounted traffic railings or for corridor uniformity. Approval by the District Design Engineer is required for the use of Class 5 coatings, tints~~

~~or stains. Class 5 coatings, tints or stains may be applied to roadway concrete barriers in order to be compatible with the treatment of bridge or retaining wall mounted traffic railings or for corridor uniformity. The following approvals are required for use of Class 5 coatings:~~

- ~~(1) District Design Engineer approval when applied on the outside of concrete barriers.~~
- ~~(2) Chief Engineer approval when applied to median barriers and the inside and top surfaces of concrete barriers.~~

Commentary on Update: On 7/28/2020 By Richard Stepp.

Date of presentation:

- 215.8 – Non-Standard Roadside Safety Hardware

215.8 Non-Standard Roadside Safety Hardware

The use of Non-Standard Roadside Safety Hardware must be approved by the State Roadway Design Office (RDO). Roadside Safety hardware that is not listed on the APL, not shown in the Standard Plans, ~~or not used for the Department's intended applications~~ is considered Non-Standard. The APL includes proprietary devices and products that have been evaluated for compliance with FDOT Standard Specifications and the Standard Plans. The majority of proprietary roadside safety hardware eligible for use on

FDM 216 (Earthwork)

Commentary on Update: FDM and Specification definitions of Regular Excavation and Subsoil Excavation were not consistent. Added the Specification definitions to the FDM verbatim to prevent any misinterpretations.

Date of presentation:

- 216.1 – General

216.1 → General ¶

Earthwork is a generic term for all items of work, materials and operations required to construct the excavated areas and the embankments of a project. ¶

FDOT Specifications – Sections 110, 120, and 125 define the terms, method of measurement, basis of payment, and pay items associated with earthwork. ¶

In general, earthwork on a highway project consists of: ¶

- → **Clearing and Grubbing** – Complete removal of existing flexible pavement (asphalt and base) and rigid pavement. **See Standard Specifications Section 110 for additional requirements.** ¶
- → **Embankment** – Compacted fill material needed to construct the roadway. ~~This typically excludes the base and pavement portions of the roadway and shoulders, unless the EOR specifies for them to be incorporated into the fill material.~~ **See Standard Specifications Section 120-120 for additional requirements.** ¶
- → **Regular Excavation** – ~~See Standard Specifications Section 120 for definition~~ **additional requirements** ~~Excavation necessary for the construction of the roadway, ditches, ponds, channel changes, or sidewalks.~~ ¶
- → **Subsoil Excavation** – ~~See Standard Specifications Section 120 for definition~~ **additional requirements**. ~~Excavation, removal and disposal of any material that is unsuitable in its original position and that is excavated below the finished grading template.~~ ¶
- → ¶
- → **Excavation for Structures and Pipe** – ~~See Standard Specifications Section 125 for additional requirements.~~ ¶

The most important roadway operation involving earthwork is constructing the roadbed. The roadbed is constructed by excavating soil from cut sections and placing soil as embankments in fill sections. In cut sections, the roadbed is built below the original ground ~~line~~ **the original ground soil** is excavated to the elevation of the proposed roadbed. ¶

Figure-216.1.1 → Examples of Cut and Fill Limits and Details

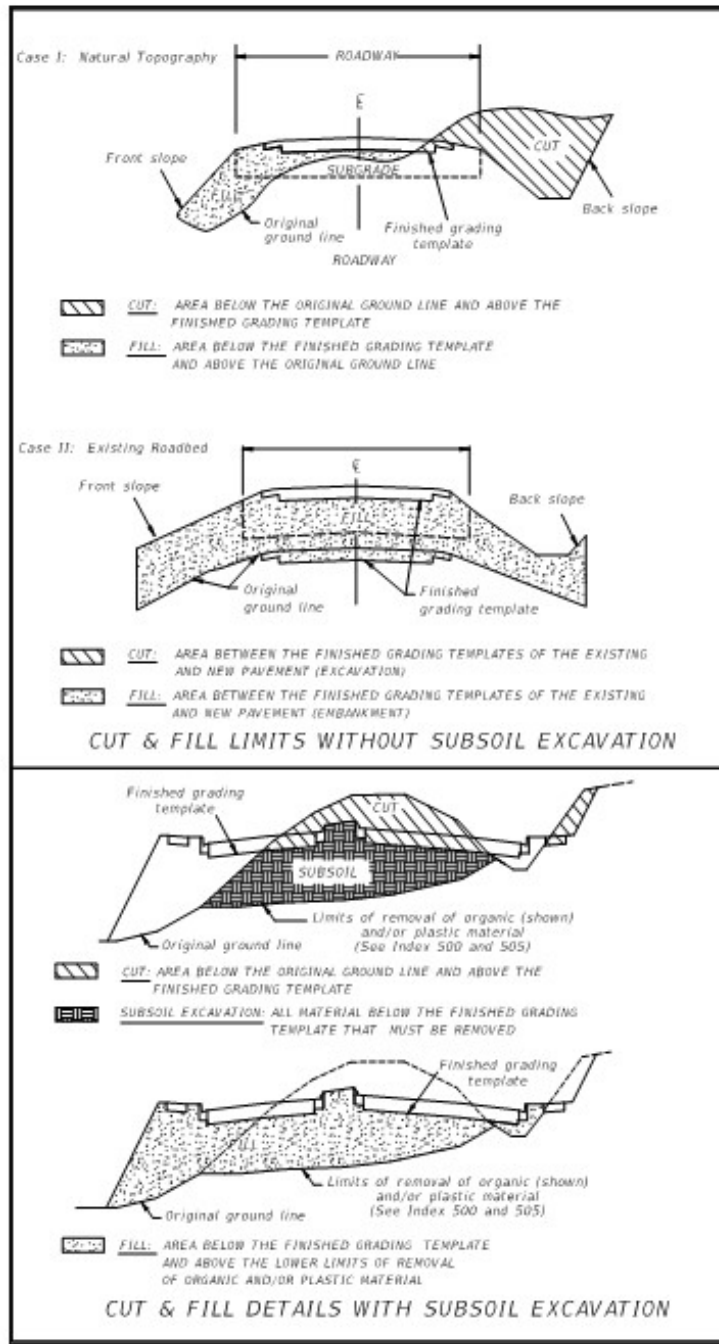

In fill sections, the roadbed is built above the original ground line. ~~the earth fill is on an soil is placed as~~ embankment ~~to the elevation of the proposed roadbed.~~ The original ground line is defined as the contour of existing natural topography, ~~including the top surface of existing pavement.~~ ¶

~~For projects involving construction over existing roadbeds:~~ ¶

~~Removal of existing flexible and rigid pavement is included in the Clearing and Grubbing pay item, as defined in Section 110. The clearing and grubbing depth within the existing pavement structure may vary since the existing shoulder and roadway bases are likely at different elevations (unless the existing shoulder was constructed at full depth).~~ ¶

~~Excavation involves removal of material below the finished grading template of the existing pavement. The finished grading template is defined as the contour of the finished side slopes, unpaved shoulders, and the bottom of the shoulder and roadway base (clearing and grubbing limit) for flexible or rigid pavement. Calculate embankment quantities from the bottom of the existing base. ¶ For projects that involve construction over existing roadbeds, calculate embankment quantities as follows:~~ ¶

~~Where asphalt pavement (flexible or rigid) and base are broken up and incorporated into the fill, the calculation is taken from the bottom of the existing base.~~ ¶

~~→ Where pavement (flexible or rigid) asphalt and base are to remain in place, the calculation is taken from the top of the existing asphalt (i.e., the original ground line).~~ ¶

~~The finished grading template is defined as the finished shoulder and slope lines and bottom of the completed base or rigid pavement for most pavements. The Department occasionally uses stabilized bases and sand-bituminous road mixes. For these, consider the finished grading template as the top of the finished base, shoulders and slopes.~~ ¶

Figure 216.1.1 illustrates cut and fill limits and details. Additional criteria and earthwork details are found in the Standard Plans, Indexes 120-001, 120-002, and 160-001. ¶

FDOT Specifications, Sections 120 and 125 define the terms, method of measure, basis of payment and pay items associated with earthwork. For projects that involve construction over existing roadbeds, calculate embankment quantities as follows: ¶

~~Where asphalt and base are broken up and incorporated into the fill, the calculation is taken from the bottom of the existing base.~~ ¶

~~Where asphalt and base are to remain in place, the calculation is taken from the top of the existing asphalt (i.e., the original ground line).~~ ¶

216.4 → Earthwork Quantities ¶

Earthwork quantities are calculated may be checked by the method of average end areas: ¶

$$\text{CUBIC YARDS} = \frac{\text{EA1} + \text{EA2} \times \text{LENGTH}}{27} \text{ ¶}$$

¶
216-Earthwork → ¶

Topic #625-000-002 → ¶
FDOT Design Manual → ¶

¶
Each set of end areas for the different types of earthwork (subsoil excavation, regular excavation and embankment) are calculated separately and shown in the appropriate column on the cross-section sheets, as indicated in **FDM-319**. ¶

216.4.1 → Earthwork Tabulation ¶

Areas and volume for subsoil excavation, regular excavation and embankment are tabulated on the right hand side of the cross-section sheet. To properly delineate and calculate earthwork quantities, the designer must be familiar with the control lines for earthwork operations. ¶

Figure 216.4.1 → Format for the Tabulation of Earthwork Quantities ¶

(Show the appropriate tabulation on the right side of the sheet) ¶

<p>Projects With Limited or No Cross-Sections</p>	<p>¶</p>	<p>Projects With Cross-Sections</p>					
<p>See Example in FDM-216.6</p>		<p>SUBSOIL EXC.</p>		<p>REGULAR EXC.</p>		<p>EMBK.</p>	
		<p>A</p>	<p>V</p>	<p>A</p>	<p>V</p>	<p>A</p>	<p>V</p>
		<p>□</p>	<p>□</p>	<p>□</p>	<p>□</p>	<p>□</p>	<p>□</p>

▪ **216.4.2 → Earthwork Accuracy**

The calculation of earthwork volumes is not simple but, when performed with care and properly checked, many of the inaccuracies common in earthwork quantity calculations can be avoided. The primary causes for inaccurate earthwork quantities are found to be errors in calculating end areas and choosing inappropriate intervals between the cross-sections. Correct methods and techniques for computing earthwork quantities will eliminate gross errors.

There are two methods of documenting the earthwork quantities for projects:

New construction and major reconstruction projects require the use of horizontal and vertical controlled cross sections. This is the most accurate and preferred method which involves the preparation of cross sections to define the quantities of earthwork involved.¶

- (1) → Calculate end areas and volumes by computer, when possible, and print the calculations for verification and future use by others.¶
- (2) → Plot cross section details at the largest scale the sheets will permit. Care should also be taken when plotting slopes that extend over long distances.¶
- (3) → If end areas are calculated from cross sections manually, show the breakdown of areas, etc. on the **Design-Backup** worksheets in the **Summary of Earthwork.xlsx** file.¶
- (4) → When computing volumes, determine lengths between sets of end areas to compensate for volumes that do not run the entire lengths between the normal station lengths.¶
- (5) → Properly use match lines and turning lines to divide end areas when separate lengths should be used to calculate volumes.¶
- (6) → Reduce the interval between cross sections to 25 feet or less on ramps or sharp turning roadways, or determine and use the centroid of the section as the length for computing volumes.¶
- (7) → Exclude bridge spans, large culverts or other exceptions where earthwork is not required.¶
- (8) → Include quantities for fill slopes under bridges, at guardrail installations and at culvert extensions. Show extended shoulder slope on cross sections at guardrail locations (not steeper than 1:10 per the **Standard Plans, Index 536-001**).¶
- (9) → Make sure that the fill for all subsoil excavation is included in the embankment quantities.¶

RRR, intersection improvements, and minor widening projects may use working typical sections that are not horizontal and vertical controlled. These projects must meet the requirements for payment by Regular Excavation (RRR Projects Only) - Lump Sum (see **FDM-216.5.1.2**).¶

- (1) → Include PDF files of working typical cross sections in the \calculations sub directory under the proper directory for all locations where there is a change in either the existing or proposed templates.¶
- (2) → Working typicals should include the station limits of the typical, and the end areas of all cut and fill sections. Working typicals may be placed in the plans, but are not required.¶

RRR, intersection improvements, and minor widening projects may use working typical sections that are not horizontal and vertical controlled. These projects must meet the requirements for payment by Regular Excavation (RRR Projects Only) – Lump Sum (see **FDM 216.5.1.2**).

- (1) — Include PDF files of working typical cross sections in the \calculations sub-directory under the proper directory for all locations where there is a change in either the existing or proposed templates.
- (1) — Working typicals should include the station limits of the typical, and the end areas of all cut and fill sections. Working typicals may be placed in the plans, but are not required.
- (2) — The thickness of the base box is calculated on the most probable base option. A plan note should also be shown in the plans stating which option was used for calculating the earthwork quantities.

- (3) — Extra fill material needed for the extended shoulder for guardrail placement should be documented on the **Design Backup** worksheets in the **Summary of Earthwork.xlsx** file with the final quantity being tabulated on the summary of earthwork. The quantity should be based on working typical sections showing the extended shoulder slope on cross sections at guardrail locations (not steeper than 1:10 per the **Standard Plans, Index 536-001**).

It is critical that the designer choose which method of documenting the earthwork quantities is best suited for their project with input from construction.

216.4.3 — Variation in Quantities

When detailing and determining earthwork quantities, use the most probable base option within the optional base group. A plan note should also be shown in the plans stating which option was used for plotting the cross sections and calculating the earthwork quantities (see **FDM 307.2.1**).

.216.45 → Earthwork Pay Items¶

Table 216.45.1 provides guidelines for selecting the appropriate earthwork pay items.¶

Table-216.45.1 → Guidelines-for-Selecting-Earthwork-Pay-Items

Description	Control-Lines	Recommended Pay-Items		
		(A) Projects with Cross-Sections	(B) Projects with Limited or No Cross-Sections	
<p><u>Case I (Natural Topography):</u> Earthwork operations above the original ground line and below the finished grading template</p> <p><u>Case II (Above Existing Pavement):</u> Earthwork operations above the finished grading template of existing roadbed</p>	Fill	<p><u>Case I:</u> from original the bottom of the base original ground line ground to the finished grading template</p> <p><u>Case II:</u> between the finished grading templates of the existing and new pavement</p>	Embankment (CY)	Borrow Excavation (Truck-Measure) (CY)
<p><u>Case I (Natural Topography):</u> Earthwork operations below the original ground line and above the finished grading template</p> <p><u>Case II (Below Existing Pavement):</u> Earthwork operations below the finished grading template of existing roadbed</p>	Cut	<p><u>Case I:</u> from original ground line to the finished grading template</p> <p><u>Case II:</u> between the finished grading templates of the existing and new pavement</p>	Regular Excavation (CY)	Regular Excavation (3-R-Projects) (LS)
<p><u>Earthwork-Subsoil:</u> earthwork operations below the original ground line and below the finished grading template</p>	Cut	<p>from the finished grading template or original ground line (whichever is lower) to the lower limits of removal of organic or plastic material</p> <p>¶</p> <p>¶</p> <p>¶</p>	Subsoil-Excavation (CY)	Subsoil-Excavation (CY)

	Fill ^{xx}	from the lower limits of removal of organic or plastic material removed to the finished grading template ^{xx}	Embankment [¶] (CY) ^{xx}	Borrow Excavation [¶] (Truck-Measure) [¶] (CY) ^{xx}	xx
With significant quantities of lateral ditch or channel excavation the designer may select to pay for separately ^{xx}		from finished original ground line to the finished grading template ^{xx}	Lateral Ditch Exc. [¶] Channel Exc. [¶] (CY) ^{xx}	N/A ^{xx}	xx
Notes: [¶] 1. → Pay items listed in column (A) cannot be used in conjunction with those listed in column (B). ^{xx}					xx

Topic #625-000-002- → FDOT Design Manual → ¶

216.45.1 → Regular Excavation[¶]

This is the most general classification of earthwork excavation. Roadway excavation consists of the excavation and the utilization or disposal of all materials necessary for the construction of the roadway, ditches, channel changes, etc., except for removal of existing pavement as defined in Section 110. When Lateral Ditch or Channel excavation pay items are not called for in the plans, the total quantity of all excavation must be paid for as Regular Excavation. ~~Regular Excavation may include roadway, pond and ditch excavation.~~ Roadway Excavation consists of the net volume of material excavated between the ~~original ground line~~ bottom of base and the original ground line (natural topography) or finished grading template of the roadway on existing roadbed, as applicable, and the finished grading template of new pavement.[¶]

. 216.45.1.1 Stormwater Treatment Ponds[¶]

Retention or detention areas that require considerable excavation should be summarized separately and added to the Regular Excavation. This is especially important if there is a large quantity and the area is removed from the project by some distance.[¶]

Some environmental permits now require that the plans call for excavating additional depth below the finish elevation of the bottom of a pond or ditch. They also require that the area of extra depth be replaced with "blanket material" that will either allow for percolation or not allow for percolation as required by the permit. The drawing below shows the limits of pay for excavation in this situation. The depth and type of fill material must be identified in the plans.[¶]

Figure-216.5.1 → Pond-Template¶

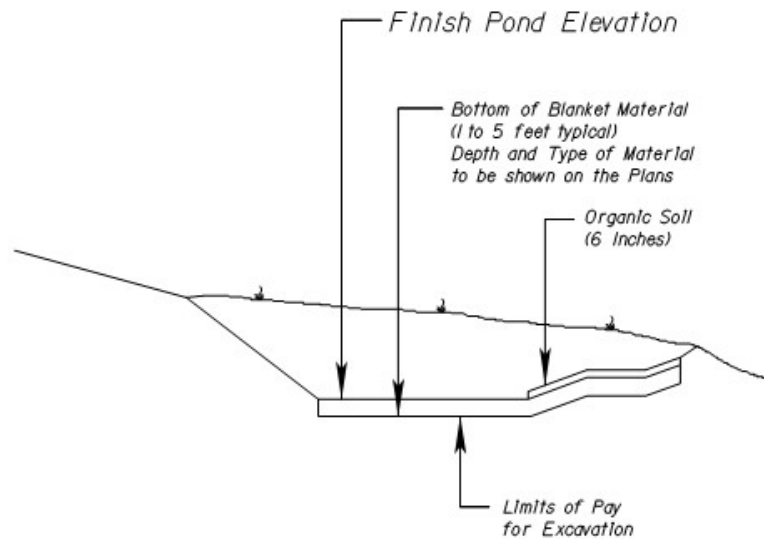

¶ 216.45.1.2 → Regular Excavation (RRR Projects Only) RRR Lump Sum Projects ¶

The pay item for Regular Excavation (RRR Projects Only) -- Lump Sum is used on resurfacing (RRR) projects that meet the following conditions: ¶

- (1) → There are limited or no cross sections on the project. ¶
- (2) → Existing typical sections are reasonably consistent throughout the project. ¶
- (3) → If utility adjustments are a consideration on the project, the designer will need to be sure that sufficient data is available to allow the utility to be relocated or adjusted. ¶
- (4) → There are no right-of-way requirements on the project. ¶
- (5) → There is no change in the existing horizontal or vertical alignment. ¶
- (6) → There are no major special ditches on the project. ¶
- (7) → There are no major intersection modifications. ¶

(8) → Show quantity of Excavation in [Summary-Box](#) [Summary of Earthwork](#), but pay for as 1 Lump Sum. ¶

Regular Excavation (RRR Projects Only) - Lump Sum may be used on intersection improvements and minor widening projects if they comply with the same listed above. ¶

Earthwork will be paid for as Borrow Excavation (Truck Measure) and Regular Excavation (RRR Projects Only) - Lump Sum. The designer will calculate these quantities based on information obtained from the field and the proposed typical section. The designer must conduct a thorough field review to ensure existing field conditions are accurately reflected in earthwork estimates. ¶

216.5.2 → Embankment ¶

~~This item includes placing material above the original ground line, or above the lower limits of removal of organic or plastic material to the finished grading template. Refer to [FDM-210.4](#) and [211.4](#) for additional requirements for shoulder gutters.~~ ¶

216.45.3 → Subsoil Excavation ¶

Subsoil Excavation consists of the excavation and disposal of any material that in its original position is excavated below the finished grading template or original ground line, whichever is lower. ¶

The soils investigation survey documents the organic or plastic material found on the project. Likewise, the cross sections and the earthwork calculations must use the lower limits of removal of organic or plastic material in determining the quantities for Subsoil Excavation. ¶

Where future widening of the roadway is anticipated, specify the limits of removal necessary to accommodate the future widening. ¶

At some locations the complete removal of organic or soft soils may not be practical due to the depth. Review the subsoil excavation with the Geotechnical Engineer of Record and where constructability concerns exist, consult with the District Geotechnical Engineer to review design alternatives. If a geosynthetic reinforced design is selected, refer to **FDM-263** for plan content and design requirements. Additional information concerning geotechnical design can be found in the [Soils and Foundations Handbook](#). ¶

Where subsoil excavation is required due to plastic soils, ensure that adequate drainage of the pavement subgrade is provided. **Figure 216.45.2** illustrates the required excavation undercut line (i.e., grade and extent of excavation bottom) for flush shoulder

roadways. To accommodate normal undercuts, the side ditches should be at least 3.5 feet below the shoulder break. ¶

For curbed roadways, additional subsoil excavation may be needed beyond that shown in **Figure 216.45.2** or underdrains must be installed in accordance with **Standard Plans Index 120-002**. Coordinate the removal of plastic materials with the Drainage Engineer of Record, as it may affect various drainage design elements including the profile grade of the ditch bottoms. ¶

~~Tabulate subsoil excavation areas and volumes on the right side of the cross-section sheets.~~ The ~~fill-embankment~~ quantities (areas and volumes) ~~must include~~ may be checked by calculating the areas and volumes required to fill the excavated areas created by subsoil removal. See example given in **FDM 216.1**. ¶

Do not include the payment for subsoil excavation in the pay quantities for other items no matter how small the subsoil quantity. ¶

..... Page Break ¶

Figure-216.45.2 → Undercut-Detail-of-Plastic-Material-with-Relation-to-Side-Ditches

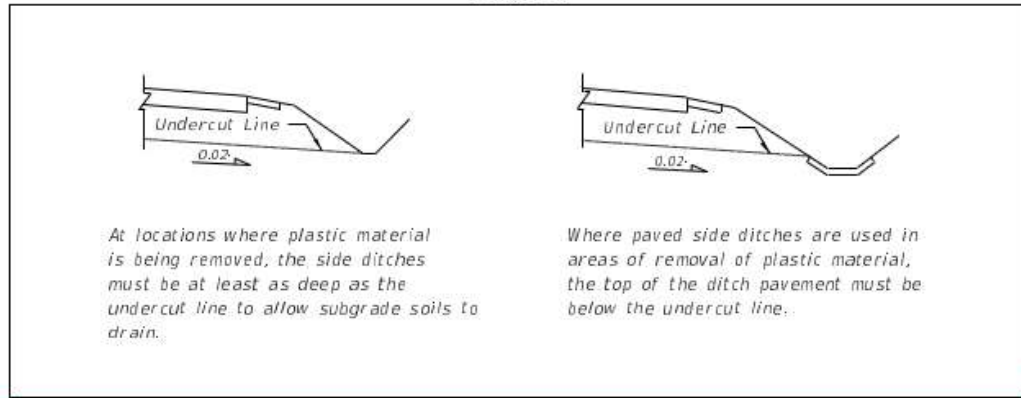

Embankment (fill) or Regular Excavation (cut) should be used in conjunction with the pay item Subsoil Excavation. Both Embankment and Regular Excavation are plan quantity items. The quantities are based on line and grades shown in the plans and would allow construction personnel to field verify the quantities of material used on a project. Subsoil Excavation is a field measure item, and the final pay quantity will be determined by cross-section taken when the removal of the material is completed.¶

.216.45.4 → Lateral-Ditch-Excavation¶

Excavation required to construct inlet and outlet ditches at structures, changes in channels of streams and ditches parallel to the right of way, but separated from the roadway template, may be designated by the designer as Lateral Ditch Excavation.¶

On projects with very little of this type of excavation, this earthwork is usually included in the Regular or Roadway Excavation. If there is a significant amount of Lateral Ditch Excavation, it should be detailed, calculated and summarized [on separate cross-section sheets and shown](#) separately in the [Earthwork Summary of Earthwork](#).¶

Quantities for **Excavation for Structures and Pipe** must not be included in the quantities for Lateral Ditch or other excavation pay items.¶

216.45.5 → Channel Excavation¶

The pay item for Channel Excavation consists of the excavation and satisfactory disposal of all material from the limits of the channel as shown in the plans. This work is generally called for by the plans and has lines, grades, typical sections and other details shown for excavating a channel change or a major modification to an existing channel or stream. This work may be significantly different from regular excavation or lateral ditch excavation, requiring draglines, barges or other special equipment. It is typically detailed, calculated and summarized separately.¶

216.45.6 → Borrow Excavation (Truck Measure)¶

The pay item for Borrow Excavation (Truck Measure) is only used on projects with limited or no cross sections. It is used to indicate that the contractor is to furnish earthwork material from areas provided by him and generally outside the project limits. This could include material with a specific minimum bearing value for building up existing shoulders, when appropriate for the project.¶

Borrow material may be obtained from within the right-of-way of the project, if available. The proposed borrow areas must be reviewed and coordinated with the District Environmental Coordinator to minimize environmental disturbance and promote a future original appearance.¶

When the designer chooses the method of payment as Borrow Excavation (Truck Measure), a fill adjustment must be made to the net total fill material calculated from the plans to allow for handling. An additional adjustment (truck) is added to obtain a representative volume of material required. This is not a plan quantity item, but it is very important that a realistic determination of quantities be calculated by the designer.¶

216.4.7 → Embankment¶

This item includes placing material above the original ground line (areas of natural topography), finished grading template (areas of existing roadbeds), or above the lower limits of removal of organic or plastic material, as applicable, to the finished grading template of new pavement. Refer to *FDM 210.4* and *211.4* for additional requirements for shoulder gutters.¶

¶
216.5 → **Earthwork Quantities**¶

Earthwork quantities may be checked by the method of average end areas.¶

$$\text{CUBIC YARDS} = \frac{\text{EA1} + \text{EA2} \times \text{LENGTH}}{2}$$

¶
¶
216.5.1 → **Variation in Quantities**¶

¶
When detailing and determining earthwork quantities, use the most probable base option within the optional base group. A plan note should also be shown in the plans stating which option was used for plotting the cross sections and calculating the earthwork quantities (see *FDM-307.2.1*).¶

¶
216.6 → **Summary of Earthwork**¶

A subtotal for each group ~~or cross section~~ (e.g., mainline, side street, pond) should be shown in the Summary of Earthwork ~~box~~ for each earthwork operation (subsoil excavation, regular excavation and embankment). This summary should be shown on the Summary of Earthwork in the Estimated Summary of Quantities Report sheet. See *FDM-902307* for information on Estimated Quantities Summary of Quantity Report sheets.¶

Figures 216.6.1 and 216.6.2 show See Chapter 8 of the *BOE* for examples of Summary of Earthwork boxes.¶

Topic #625-000-002-
 FDOT-Design-Manual

Figure-216.6.1 is an example of a Summary of Earthwork box for projects with cross sections. The summary should document all the groups' totals in one location.

Figure-216.6.1 → Summary of Earthwork Box
 (Projects with Cross Sections)

SUMMARY OF EARTHWORK					
PAY ITEM NO.	PAY ITEM DESCRIPTION	CY		DESIGN NOTES	CONSTRUCTION REMARKS
		P	F		
0120 1	REGULAR EXCAVATION	10000.0		MAINLINE	
		800.0		SIDE STREET NAME	
		1005.0		POND NO. 1	
	TOTAL	11805			
0120 3	LATERAL DITCH EXCAVATION	5000.0			
0120 4	SUBSOIL EXCAVATION	2080.0		MAINLINE	
		1100.0		SIDE STREET NAME	
	TOTAL	3180			
0120 6	EMBANKMENT	20000.0		MAINLINE	
		7000.0		SIDE STREET NAME	
	TOTAL	27000			

Topic #625-000-002
 FDOT Design Manual

Figure-216.6.2 is an example of a summary of earthwork box that should be used for projects with limited or no cross sections. The summary should show all quantities and adjustments. The adjustment percentages shown are for example only; contact District Materials or Construction Office for actual percentages to be used for each project.

Figure-216.6.2 → Summary of Earthwork Box
 (Projects with Limited or No Cross Sections)

SUMMARY OF EARTHWORK					
PAY ITEM NO.	PAY ITEM DESCRIPTION	CY		DESIGN NOTES	CONSTRUCTION REMARKS
		P	F		
0120 2 2	BORROW EXCAVATION				
	FILL	253.0			
	GUARDRAIL LOCATIONS	70.0			
	CROSS DRAINS	100.0			
	SUB TOTAL	423.0			
	FILL ADJUSTMENT (20%) (423 X 0.20)	85.0			
	SUB TOTAL	508.0			
	TRUCK ADJUSTMENT (25%) (508 X 0.25)	127.0			
	TOTAL BORROW EXCAVATION	635			
0120 71	REGULAR EXCAVATION (RR PROJECTS ONLY)	200		LS-QTY FOR REFERENCE ONLY	

The pay items used will be: → ¶

Regular Excavation (RRR Projects Only) → 1 (LS) ¶
 Borrow Excavation (Truck Measure) → → 635 CY ¶

FDM 220 (Railroads)

Commentary on Update: Change made 7/30/2020 by Bobby Bull.

Date of presentation:

- 220.1.3 – Required Coordination

(5) Coordinate with the District Rail Coordinator when a waiver is being considered for standard lateral offset requirements for structures; see **FDM 220.3.2**.

Some railroads may require an increase in Railroad Protective Liability Insurance greater than what is provided in the **Standard Specifications**. The District Specifications Engineer and the District Rail Coordinator will develop a Modified Special Provision and submit it through the Central Specifications Office for special processing. For projects involving CSX Railroad use Special Provision SP0071303.

Commentary on Update: Change made 2/14/2020 Per RDB 20-02.

Date of presentation: 1/23/2020 via e-mail per Gevin McDaniel

- 220.2.1.1 – Signing and Pavement Markings

220.2.1.1 Signing and Pavement Markings

Include signing and pavement markings in accordance with **Standard Plans, Index 509-070**.

Include Railroad Dynamic Envelope (RDE) pavement markings at the following at-grade railroad crossings on:

- State Roads,
- State-owned rails, and
- State-owned property.

For side roads with at-grade crossings within 100 feet of the edge of traveled way, include W10-2, W10-3 or W10-4 signs on the mainline state road in accordance with the **MUTCD**.

For pavement marking material selection, see **FDM 230**.

Commentary on Update: Change made 2/14/2020 Per RDB 20-02.

Date of presentation: 1/23/2020 via e-mail per Gevin McDaniel

- 220.2.1.2 – Preemption

220.2.1.2 Preemption

FDM 221 (Utilities)

Commentary on Update: Removed "(Topic No. 710-010-050)" due to it not existing. Later replaced "Process" with "Letter" as the process is currently referred to as a Letter.

Date of presentation: 7/16/2020 via e-mail per William Summers & Shawn Lewis, then again on 8/3/2020 after Teams meeting with further explanation.

- 221.2 – Utility Work Schedules and Agreements

221.2 Utility Work Schedules and Agreements

Certify the project in accordance with **Utility Work Agreements and Certification Letter**~~Process (Topic No. 710-010-050)~~. With assistance from the District Utilities Office and the Office of General Counsel, obtain the following:

FDM 222 (Pedestrian Facilities)

Commentary on Update: On 1/15/2020 by James McGinnis

Date of presentation:

- 222.2.1 –Sidewalk

For RRR Projects, other than meeting detectable warning and curb ramp requirements, unaltered sidewalks that are not in compliance with **FDM criteria**, **Standard Plans**, or ADA requirements are not required to be reconstructed.

222.2.1.1 Sidewalk Width

Commentary on Update:

Date of presentation: On 5/11/2020 by email per Derwood

222.2.2 – Curb Ramps and Blended Transitions

222.2.2 → Curb Ramps and Blended Transitions¶

~~Sidewalk Curb Ramps are designed based on accessibility guidelines from the Americans with Disabilities Act Standards for Transportation Facilities 2006. Sidewalk Curb Ramp preferences in the **Standard Plans, Index 522-002** are taken from the Public Rights of Way Accessibility Guidelines (PROWAG) 2011. ¶~~

~~**Standard Plans, Index 522-002** provides requirements and details for curb ramps and landings that are compliant with Americans with Disabilities Act Standards for Transportation Facilities¶~~

~~A continuous accessible pedestrian route, including curb ramps, and blended transitions landings and transition areas (e.g., depressed corners, raised street crossings, flush roadway connections) are required along sidewalks and shared use paths pedestrian networks. Additional information, nomenclature, requirements, and details for curb ramps and landings are provided in the **Standard Plans, Index 522-002**.¶~~

~~Alpha identifications have been provided in Index 522-002 for the various curb ramp options (e.g. CR-A, CR-B, etc.) to facilitate ease of callouts in the Plans. Use the curb ramp options as follows: ¶~~

¶
222-Pedestrian Facilities¶

Topic #625-000-002¶
FDOT Design Manual¶
¶

~~• Curb Ramps CR-A, CR-B & CR-C are for use where ramp and landing depths are not restricted.¶~~

~~• Curb Ramps CR-D, CR-E, CR-F, CR-G and CR-H are for linear pedestrian traffic.¶~~

~~• Curb Ramps CR-K and CR-L are for use where ramp and landing depths are restricted.¶~~

Where pedestrian push buttons are present, provide a level (less than or equal to 2 percent surface slope in any direction) landing at all pedestrian pushbutton locations. The landing must provide a clear ground space area of 30 inches by 48 inches directly in front of pedestrian pushbuttons to allow persons using a wheeled mobility device to actuate the button while remaining stationary. Horizontally center the 48-inch dimension, parallel to the button face, must be horizontally centered on the pushbutton.

Figure 222.2.1 Curb Ramp Nomenclature

When compliance with Department curb ramp requirements is determined to be technically infeasible (i.e. no engineering solution is available), documentation as a Design Variation is required. This may occur where existing right of way is inadequate and where conflicts may occur with existing features which cannot be feasibly relocated or adjusted (drainage inlets, signal poles, pull and junction boxes, etc.).

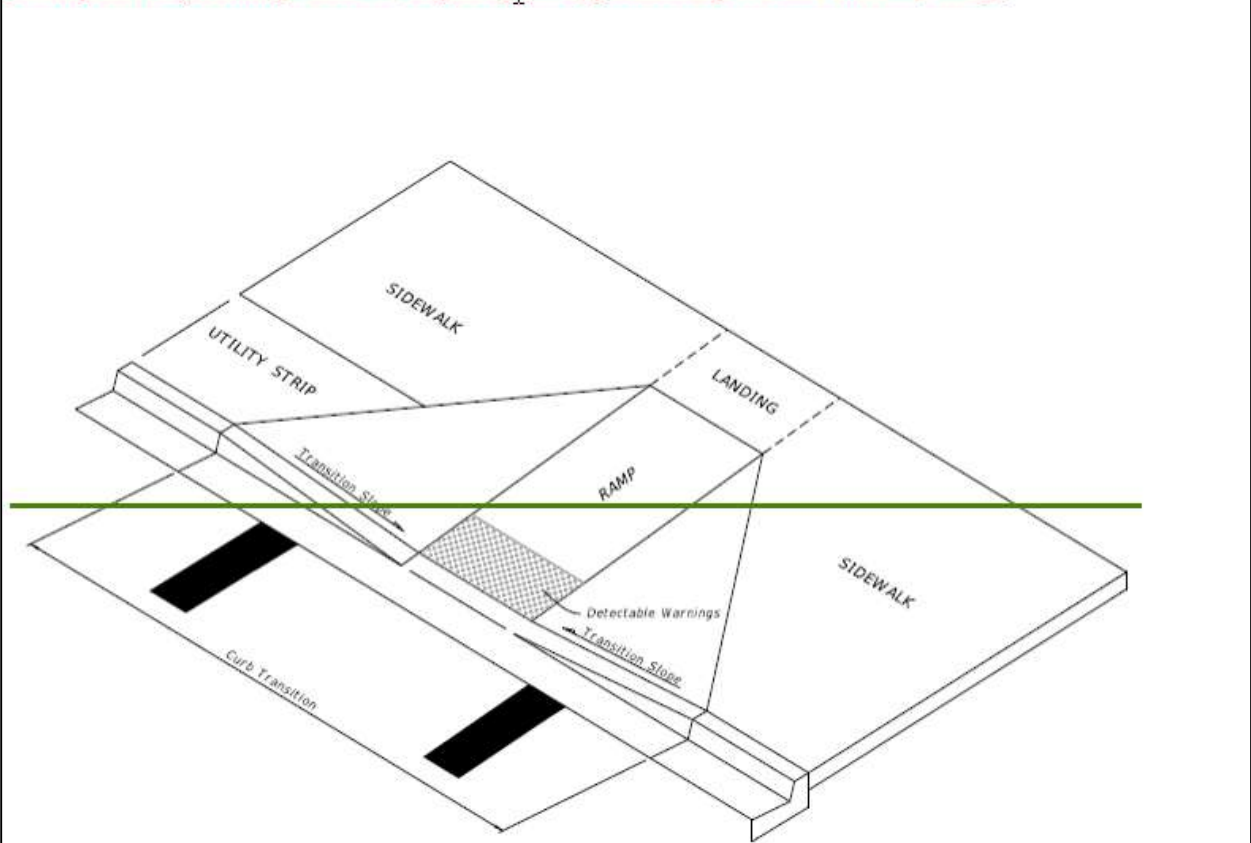

Commentary on Update: On 3/31/2020 by James McGinnis.

Date of presentation:

- 222.2.3.1 – Intersections

For six-lane divided roadways or crossing distances exceeding 80 feet, consider installing a two-stage pedestrian crossing with median refuge island. For more information on marked pedestrian crosswalks see the [Traffic Engineering Manual \(TEM\) Section 5.23.8](#).

Commentary on Update: On 3/31/2020 by James McGinnis and Bobby Bull.

Date of presentation:

- 222.2.3.2 – Midblock

222.2.3.2 Midblock

Use Special Emphasis crosswalk markings at midblock crossings. For illustrations of midblock crosswalks see **FDM 230.6**.

Midblock crosswalks are used to supplement pedestrian crossings in areas between intersections. Midblock crosswalks should be illuminated, marked, and signed in accordance with the [MUTCD](#), [Traffic Engineering Manual \(TEM\)](#), (**Section 5.23.8**), **FDM 230.6**, and **FDM 231.3.4**.

Midblock crosswalks should not be located where any of the following exist:

~~The spacing between adjacent intersections is less than 660 feet.~~

- (1) The distance from the crosswalk to the nearest intersection (or crossing location) is less than 300 feet.
- (2) The crossing distance exceeds 60 feet (unless a median or a crossing island is provided).
- (3) The sight distance for both the pedestrian and motorist is not adequate.
- (4) The crosswalk cross slope (roadway profile) exceeds 5%.
- (5) The crosswalk grade (roadway cross slope) exceeds normal crown.

Commentary on Update: On 8/26/2020 by James McGinnis.

Date of presentation:

- 222.2.3.2 – Midblock

For additional information on the requirements of an engineering study, refer to the Department's [TEM](#), (Section [5.23-8](#)) and [Manual on Uniform Traffic Studies \(MUTS\)](#).

See [Figures 212210.3.4-13.3](#) and [212210.3-13.4.5](#) for examples of midblock crossings with refuge islands.

Commentary on Update: On 6/9/2020 by Gevin McDaniel.

Date of presentation:

- 222.2.4 – At-Grade Railroad Crossings

Place detectable warnings on each side of the railroad crossing as illustrated in [Figure 222.2.12](#).

Commentary on Update: On 6/9/2020 by Gevin McDaniel

Date of presentation:

- 222.2.5 – Refuge Island

222.2.5 Refuge Islands

See [FDM 212210.13.3](#) for information on refuge islands.

Commentary on Update: Change made 2/6/2020

Date of presentation: 9/20/2019 via meeting per Mary O'Brien

- 222.2.6 – Curb Extensions (Bulb-Outs)

222.2.6 Curb Extensions (Bulb-Outs)

Curb extensions (a.k.a., bulb-outs) may be used in conjunction with on-street parking at intersections or midblock locations where there is a crosswalk, provided there is adequate width for existing traffic movements. Curb extensions shorten the crossing distance, and provide additional space at intersections, allowing pedestrians to see and be seen before entering a crosswalk.

The design of curb extensions must take into consideration the needs of transit vehicles, drainage, and bicyclists. [Consult with a district drainage engineer on drainage accommodations for the curb extension during Phase I of the design.](#) See [the **Drainage Design Guide**](#) and [Figure 222.2.23](#).

Commentary on Update: On 5/20/2020 by Gevin McDaniel

Date of presentation:

- Figure 222.2.11 – Street Furniture

222.2.11 Street Furniture

Street furniture may include benches, lighting fixtures, transit shelters, and bicycle parking. These items may be placed within the R/W under certain conditions. Ensure items do not obstruct sight distance or visibility of pedestrians at crosswalks. Do not use street furniture on curb extensions.

Refer to **FDM 223.2.5** for information on bicycle parking facilities amenities, and **FDM 225** for information on public transit facilities. Appropriate types of street furniture may vary based on frequency and density of pedestrian activity. Street furniture must allow for minimum sidewalk width and meet lateral offset requirements identified in **FDM 222.2.1.1** and **222.2.1.2**.

Commentary on Update: On 5/13/2020 by Gevin McDaniel.

Date of presentation:

- Figure 222.3 – Detectable Warnings

222.3 Detectable Warnings

Detectable warnings are a distinctive surface pattern of domes detectable by cane or underfoot that alert people with vision impairments of their approach to street crossings. Install detectable warnings to cover the full width of the walking surface and 2 feet deep. They are required on sidewalks at the following locations:

- Curb ramps and transition areas at street crossings
- Cut-through-p Pedestrian refuge islands or medians six feet wide or greater where there is one or more of the following:
 - Change in surface texture
 - Change in elevation (e.g., curb ramp)
 - Change in horizontal alignment of the path within the refuge island
 - Two-stage crossings
- Pedestrian at-grade railroad crossings

FDM 223 (Bicycle Facilities)

Commentary on Update: Changes made 4/16/2020

Date of presentation: 4/16/2020 via e-mail per Gevin McDaniel after discussions with DDEs & DRDEs

- 223.2.1.3 – Keyhole Lanes

223.2.1.3 Keyhole Lanes

A keyhole lane is a bicycle lane that is placed between a through lane and the adjacent right turn lane, bus bay, or parking lane. Provide a keyhole lane on curbed roadways that have a bicycle lane approaching the intersection, bus bay, or parking lane. On curbed roadways that do not have a bicycle lane approaching the intersection, consider providing a 17-foot right-turn lane for development of future bicycle facilities.

~~Provide a~~ keyhole lane ~~should be provided~~ on flush shoulder roadways ~~that have marked shoulders (per FDM 223.2.2.1) on the approaching paved shoulders. Consider providing a keyhole lane on flush shoulder roadways where the approach shoulder is not marked and high levels of bicycle traffic exist or are anticipated.~~ of any design speed where the approaching or departing paved shoulder is of at least 4 feet in width.

Provide a 7-foot buffered keyhole lane on curbed roadways; however, when 7 feet is not obtainable, provide the greatest keyhole lane width possible, but not less than 5 feet. The keyhole lane should match the width of the shoulder on flush shoulder and ~~high speed~~ high-speed curbed roadways, but not less than 5 feet. |

Include Helmeted Bicyclist Symbol and Bicycle Lane Arrow pavement markings in the keyhole lane. Keyhole lanes are illustrated in **Exhibit 223-2**.

~~The addition of~~ For RRR projects, a keyhole lane should be provided except on ~~is not required on RRR~~ projects that have inadequate R/W or utility conflicts.

Commentary on Update: Changes made 5/14/2020. More changes made on 6/5/2020 by Bobby Bull

Date of presentation: 4/8/2020 via Tracker

- 223.2.1.4 – Green-Colored Pavement Markings

Green-colored pavement markings supplement the required bicycle lane pavement markings and are not to be used as a substitute for such markings. ¶

The use of green-colored pavement markings requires the approval of the District Design Engineer through Project Suite's Design Approval Request Process. ~~The approval shall must be obtained during Phase I of Design.~~ The addition of green-colored pavement markings to bicycle lanes per these criteria does not require a local agency maintenance agreement. ~~For placement on existing pavement, contact the State Materials Office for additional placement requirements.~~ ¶

Use the following guidance in the placement of green-colored pavement markings for bicycle lanes: ¶

- (1) → When it is used in conjunction with white dotted lines, such as when extending a bicycle lane across a right turn lane or access to a bus bay, the transverse colored marking must match the 2'- 4' white dotted line pattern of the bicycle lane extension. ¶
- (2) → Start the green-colored pavement as a solid pattern 50 feet in advance of the dotted striping, match the 2'- 4' dotted through the conflict area, and then resume the solid color for 50 feet after the conflict area, unless such an extent is interrupted by a stop bar, an intersection curb radius or bicycle lane marking. ¶

Include quantities in accordance with the [Basis of Estimates Manual](#). Load these quantities into the Designer Interface in the Signing and Pavement Marking Category. ¶

Projects using green-colored pavement markings, ~~the EOR~~ must submit either a GIS (a.k.a., shapefile or geodatabase) or CADD (e.g., ~~dsansp.dgn, dsansp.dwg~~) file depicting

¶
223-Bicycle Facilities ¶

Topic #625-000-002 ¶
FDOT Design Manual ¶

¶
~~their location(s) these markings.~~ ~~The District Final Plans or District CADD Office unit will access the files in the GIS folder of the Final Projects folder and send them through the File Transfer Appliance (FTA) Submit the required files via email to CO-CIMGIS@dot.state.fl.us and copy the State Bicycle Pedestrian Coordinator. ¶~~

Additional details on the file format can be found in the [CADD Manual 8.4.7](#) and at the following website: <https://www.fdot.gov/gis/bim/green-pavement> ¶

Commentary on Update: On 5/12/2020 by Gevin McDaniel

Date of presentation:

- Figure 223.2.4.1 – Type of Separation

223.2.4.1 Type of Separation

~~Express lane~~**Tubular** markers, ~~raised medians (such as traffic separators)~~**islands**, on-street parking, and rigid barriers may be used as forms of separation for the appropriate design speeds as follows:

- 35 mph or less: ~~Express lane~~**Tubular** markers, ~~raised medians~~**islands**, rigid barriers, or on-street parking. For separated bicycle lanes adjacent to on-street parking, use an ~~n raised median~~**island** (see **Figure 223.2.2**).
- 40-45 mph: ~~Raised median~~**Medians, islands** or rigid barriers

Other forms of separation require approval from the State Roadway Design Engineer.

Commentary on Update: On 5/12/2020 by Gevin McDaniel

Date of presentation:

- Figure 223.2.4.2 – Width of Separation

223.2.4.2 Width of Separation

The widths of separation are as follows:

- 3 feet minimum if adjacent to on-street parking. See **Figure 223.2.2** for more information.
- If adjacent to travel lanes:
 - 35 mph or less: 6 feet preferred, 3 feet minimum unless using ~~express lane~~**tubular** markers or ~~raised medians~~**islands**, then 2 feet minimum
 - 40 to 45 mph: 8 feet preferred, 3 feet minimum.

Commentary on Update: On 3/31/2020 by James McGinnis

Date of presentation:

- Figure 223.2.4.4 – Intersections and Driveways

223.2.4.4 Pavement Markings

Pavement markings used for separated bicycle facilities must conform to the **MUTCD**, **Traffic Engineering Manual (TEM)**, or **FDM/230**. Markings that do not conform to any of these manuals require approval by the State Roadway Design Engineer and State Traffic Operations Engineer.

Commentary on Update: On 3/31/2020 by James McGinnis

Date of presentation:

- Figure 223.2.4.5 – Intersections and Driveways

223.2.4.5 Intersections and Driveways

Chapter 5 of the ***FHWA Separated Bike Lane Planning and Design Guide*** includes typical designs to address the following:

- Facility connections at intersections,
- Side streets and driveways, and
- Traffic operation tools such as bicycle signal faces and signal phasing.

See the ***TEM*** for more information on traffic operation tools.

FDM 228 (Landscape Design)

Commentary on Update: On 8/12/2020 by Rob Cotleur.

Date of presentation:

- 228.3 – Landscape Opportunity Plan

To prevent future costly and difficult retrofits, roadway projects may include provisions for landscape (e.g., irrigation sleeves, suitable soil for landscape, space for planting,

Commentary on Update: On 8/12/2020 by Rob Cotleur. Landscape moved to 228.3.2

Date of presentation:

- 228.3.1 – Required Information

228.3.1 Landscape Irrigation Sleeves

Landscape irrigation sleeves are used in locations where a future landscape project with irrigation is planned, as determined by the District Landscape Architect. ~~Irrigation sleeves are intended to be used on new construction projects, where there is an opportunity to install the sleeves in an open trench. This condition does not apply to existing roadways or directional boring operations. They are typically placed in raised medians, roundabout central islands, and under driveways. See Standard Plans, Index 591-001 for installation requirements.~~

~~Landscape irrigation sleeves typically consist of 2 adjacent pipes: one for an irrigation line, and one for an electrical control wire. Show pipe diameters in the plans. The diameter of each pipe is typically two pipe sizes larger than the carrier pipe, with the following minimum diameters:~~

- ~~Irrigation pipes – 4 inches~~
- ~~Electrical control wire – 2 inches~~

228.3.21 → Required Information¶

The landscape opportunity plan is typically produced as a roll plot format, 1" = 200' maximum. An alternate format may be approved by the Department's project manager. Submit the completed landscape opportunity plan to the Department project manager and District Landscape Architect.¶

Provide a legend, notes, and details as needed. Delineate areas for future landscape plantings in bubble format that explicitly and prioritize them into categories such as high, medium and low priority. Explicitly convey design intent, such as:¶

- → Areas with trees and shrubs for buffering differing land uses¶
- → Trees to frame desirable views¶
- → Trees and ground cover areas for stabilization of embankments¶
- → Trees to shade sidewalks¶
- → Shrubs for pedestrian channelization¶

Commentary on Update: On 8/12/2020 by Rob Cotleur.

Date of presentation:

- 228.3.2 – Landscape Irrigation Sleeves

228.3. 1-2 Landscape Irrigation Sleeves

Landscape irrigation sleeves are used in locations where a future landscape project with irrigation is planned, as determined by the District Landscape Architect. Irrigation sleeves are intended to be used on new construction projects, where there is an opportunity to install the sleeves in an open trench. This condition does not apply to existing roadways or directional boring operations. They are typically placed in under paved surfaces to connect to raised medians, roundabout central islands, and under driveways. See **Standard Plans, Index 591-001** for installation requirements.

Landscape irrigation sleeves typically consist of 2 adjacent pipes: one for an irrigation line, and one for an electrical control wire. Show pipe diameters in the plans. The diameter of each pipe is typically two pipe sizes larger than the carrier pipe, with the following minimum diameters:

- Irrigation pipes – 3 inches
- Electrical control wire – 2 inches

Commentary on Update: On 8/12/2020 by Rob Cotleur.

Date of presentation:

- 228.4 – Landscape Maintenance Guide

228.4 → Landscape Maintenance Guide

The maintenance guide is written or graphic and describes the design intent including mature size and form of plant material, offsets required to maintain clear sight, and ~~minimum tree spacing~~ any functional characteristics the landscape is intended to provide. The guide is related to activities provided by the maintaining authority, after the Contractor's establishment period has ended.

Commentary on Update: On 8/12/2020 by Rob Cotleur.

Date of presentation:

- 228.4.1 – Landscape Design Intent and Maintenance Performance Requirements

- (p) → Keep mulch beds edged
- (q) → Keep weeds from view or from affecting plant growth or health
- (r) → Remove invasive, exotic vegetation
- (s) → Control pests and disease

FDM 229 (Selective Clearing and Grubbing)

Commentary on Update: On 8/12/2020 by Rob Cotleur.

Date of presentation:

- 229.1 – General

229.1 General

Selective clearing and grubbing includes one or more of the following:

- The removal of undesirable vegetation,
- Areas of plant preservation, and
- Tree protection fencing, and
- Branch and root pruning

Areas requiring selective clearing and grubbing, tree protection, pruning or thinning, or plant preservation are determined during the design phase, but may also be identified at other project development phases. Review commitments made during the PD&E phase to determine if any of these areas were identified. Areas may also be identified during the Design phase as determined by the District Environmental Office, District Permit Office, District Landscape Architect, through public involvement, or the permitting process.

Commentary on Update: On 8/12/2020 by Rob Cotleur.

Date of presentation:

- 229.1.2 – Tree Protection

229.1.2 → Tree Protection¶

Areas with tree protection are considered selective clearing and grubbing areas, as the tree being protected is being “selected” to remain. Tree protection fencing is utilized when individual or groups of trees require preservation on individual or groups of trees have been relocated within project limits. Tree protection fencing is utilized when individual or groups of desirable trees require preservation. Place tree protection barriers at a minimum, at the dripline of trees. Consider specifying root pruning when impacts to portions of the critical root zone are unavoidable. Specify branch pruning when needed for sidewalk or roadway clearance, to improve wind resistance, or to reduce conflicts with roadway or utility features.¶

Commentary on Update: On 8/12/2020 by Rob Cotleur.

Date of presentation:

- 229.2 – Selective Clearing and Grubbing Field Assessment

- Opportunities for vegetation preservation, or selective removal of vegetation as an alternative to standard clearing and grubbing
- Opportunities for vegetation removal to create vistas or allow views into desirable areas such as ponds, forested areas or other attractive transportation features.
- Construction limits, grade change, and the anticipated impacts on surrounding vegetation

Commentary on Update: On 8/5/2020 by Rob Cotleur.

Date of presentation:

- 229.3 – Tree and Palm Relocation

Large trees take substantial time and resources to relocate. Time periods required between root pruning and relocation must be in accordance with Standard Industry standards and Supplemental Specification 581. Typically, large trees (over 16" diameter at breast height (DBH)) are not worth the risk, time, investment, and justification required to transplant.

Palms, when compared to trees, are relatively easy to relocate. Each palm species responds differently to root pruning. Develop a relocation and root pruning plan tailored to the particular species being relocated. Final approval to relocate trees and palms shall be provided by the District Landscape Architect ~~For most species of palms, root survival is strongly correlated with the distance from the trunk that the root is cut.~~

FDM 230 (Signing and Pavement Markings)

Commentary on Update: On 5/8/2020 by Gevin McDaniel.

Date of presentation:

- 230.2.7 – Object Markers and Delineators

230.2.7 Object Markers and Delineators, ~~Object Markers and Express Lane Markers~~

An object marker is used to mark obstructions within or adjacent to the roadway. The MUTCD describes four object markers and how they are to be used. A Type 1 (style OM1-3 only) or Type 3 (all styles) object marker is used to mark obstructions within the roadway. A Type 2 (style OM2-2V only) or Type 3 (all styles) object marker is used to mark obstructions adjacent to the roadway. A Type 4 (style OM4-3 only) object marker (end-of-roadway marker) is used to alert users of the end of the road.

Commentary on Update: On 5/8/2020 by Gevin McDaniel.

Date of presentation:

- 230.2.8 – Tubular Markers

230.2.8 Tubular Markers

~~T~~Aubular markers are the Department's standard device for the purpose of ~~for permanent channelizing devices~~. ~~T~~delineator is also used to mark median openings. In general, flexible delineators are used in urban context classifications and non-flexible in rural context classifications. Use tubular ~~A high visibility median delineator~~markers ~~They are~~

~~typically used~~ ~~should be used on traffic separators for channelization and at~~ the following locations ~~unless signing (e.g., R4-7 or R4-8) is otherwise required.~~ ¶

(1) → Multilane intersections where additional visibility is required for the marking of ~~the traffic separator~~ an island. ¶

(2) → Marking median openings. ¶

(3) → Nose of traffic separators. ¶

~~(2)(4)~~ → Where the ~~separator~~ island is obstructed due to crest vertical curves. ¶

~~(3)~~ → Intersections where the alignment thru the intersection is not straight, ~~and~~ ¶

~~(4)~~ → Where traditional flexible delineators are constantly being replaced. ¶

~~(5)~~ → ¶

~~(6)~~ → Hardened center lines. ¶

~~(5)~~ → Use high performance delineators only in urban context classifications where the posted speed is 45 mph or less, and where; ¶

~~(6)~~ → To preclude lane changing where it is not practicable to provide a barrier (e.g. managed lanes, buffered separated bicycle lanes, acceleration lanes) ~~the delineator is being used to maintain lane position, and~~ ¶

~~(7)~~ → ¶

~~(7)~~ → The delineator is being used to To restrict vehicle movements and control turning speeds. ¶

~~(8)~~ → The delineator is subject to being frequently hit. ¶

~~An Express Lane Marker is similar to a high performance delineator except for the height and speed application. Express Lane Markers may be used on projects where it is not feasible to provide a physical barrier between managed and general use lanes.~~ ¶

~~Identify the particular type of object marker or delineator in the plans by the use of the pay item.~~ ¶

~~Modification for Non-Conventional Projects:~~ □

~~Delete the last sentence and replace with the following:~~ ¶

~~The particular type of object marker or delineator must be identified in the plans.~~ □

Commentary on Update: On 5/27/2020 by Bobby Bull.

Date of presentation:

- 230.2.9 – Enhanced Highway Signing Assemblies

<p>230.2.98 Enhanced Highway Signing Assemblies</p> <p>Flashing beacons, highlighted signs, and electronic speed feedback signs may be used to increase the conspicuity of warning and regulatory signs.</p> <p>For school signing requirements, see Chapter 15 of the Speed Zoning Manual for Highways, Roads, and Streets in Florida.</p>

Commentary on Update: Change made 1/29/2020

Date of presentation: 1/23/2020 via e-mail per Gevin McDaniel

- 230.3 – Pavement Markings

<p>Topic #625-000-002 FDOT Design Manual</p> <hr/> <p>230.3 Pavement Markings</p> <p>Pavement marking design are to comply with Standard Specifications, Standard Plans, TEM, MUTS, and the MUTCD.</p> <p>The MUTCD was adopted by the Department as the uniform system of traffic control for use on the streets and highways of the State. This action was in compliance with Chapter 316.0745 of the Florida Statutes. The MUTCD is the national standard, and its requirements must be met, as a minimum, on all roads in the State. Where Department manuals indicate criteria which is more stringent than the MUTCD, Department criteria is to be followed. See FDM 220 for signing and pavement marking requirements for at-grade railroad crossings.</p>
--

Commentary on Update: Updated flow chart to direct designers to FDM 230.3.4 for Temporary Markings

Date of presentation:

- Figure 230.3.1 – Pavement Marking Material Selection

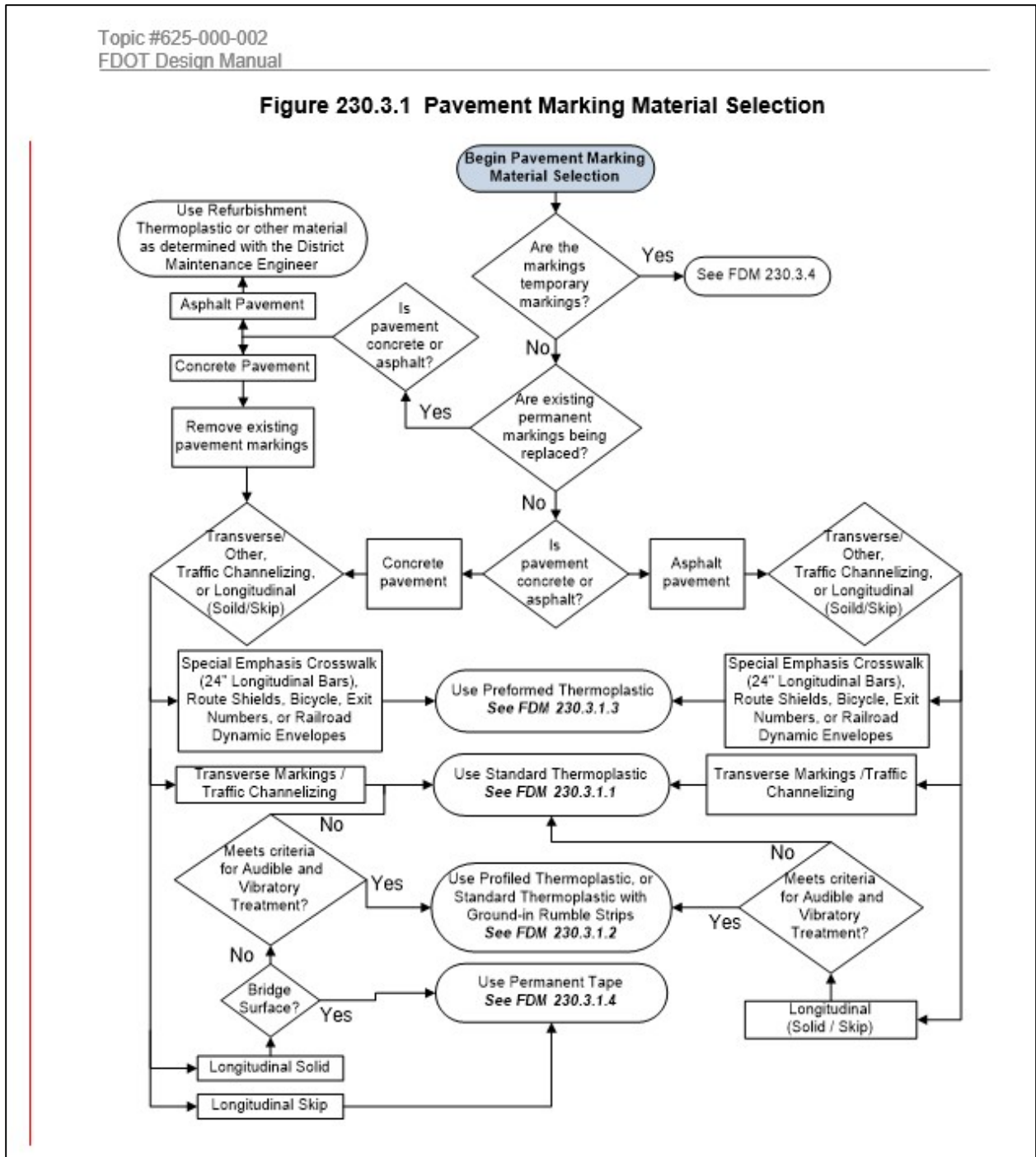

Commentary on Update: On 2/14/2020 by James McGinnis

Date of presentation:

- 230.3.1.1 – Standard and Refurbishment Thermoplastic

Coordinate with the District Maintenance Engineer to determine if black paint contrast is required for skip lines, messages, ~~and~~ arrows, and Railroad Dynamic Envelopes.

Commentary on Update: On 2/14/2020 by James McGinnis

Date of presentation:

- 230.3.1.3 – Preformed Thermoplastic

(4) Ramp Exit Numbers

(5) Roundabout informational markings

~~(5)~~(6) Railroad dynamic envelopes. When installed on concrete riding surfaces, a 4-inch wide black contrast border is required on both sides of each 12-inch wide marking.

4-inch width from the outside edge of the longitudinal bars. Provide details of black contrast border in the plans.

~~(3)~~(4) Railroad Dynamic Envelopes. A 4-inch wide black contrast border is required on both sides of each 16-inch wide marking.

Commentary on Update: On 6/29/2020 by Gevin McDaniel.

Date of presentation:

- 230.3.4 – Work Zone Pavement Markings

~~Use Removable Tape for transitions on the final asphalt surface.~~

Consider using Durable Paint or Refurbishment Thermoplastic when a work zone phase is expected to last for more than a year under heavy traffic volumes. The performance of Durable Paint has been evaluated by the Department for a period of 18 months.

Use Removable Tape for transitions on the final structural course or dense-graded friction course asphalt surface. Removable Tape may be used for other markings to avoid the removal of paint and scaring of final surface. Do not use Removable Tape for application durations of more than 6 months. Do not use Removable Tape on open-graded friction course.

FDM 231 (Lighting)

Commentary on Update: On 7/21/2020 by Richard Stepp

Date of presentation:

- 231.1 – Structural Supports

Refer to **FDM 261** for information regarding structural support requirements. Refer to **FDM 326** for information regarding [plan Lighting Plans](#) requirements.

Commentary on Update: On 7/21/2020 by Richard Stepp

Date of presentation:

- Table 231.2.1 – Lighting Initial Values

Signalized Intersection Lighting					
New <u>or</u> Reconstruction	3.0 Std. 1.5 Min.	2-31.5 Std. 1.2 Min.	4:1 or Less	10:1 or Less	N/A
Lighting Retrofit	1.5 Std. 1.0 Min.	1.5 Std. 1.0 Min.			

Commentary on Update: On 7/21/2020 by Richard Stepp

Date of presentation:

- 231.7 – Lighting Design Analysis Report

231.7 Lighting Design Analysis Report

Prepare a Lighting Design Analysis Report (LDAR) that provides a photometric analysis for each signalized intersection lighting design, mainline typical section, ramp typical section, interchange, and structure with underdeck lighting. All analyses, including horizontal and vertical illumination analyses, should be shown on separate photometric plan sheets.

Provide voltage drop calculations, load analysis calculations for each branch circuit, and lighting calculations for each lighted sign.

The LDAR should include an evaluation of three lighting design alternatives (e.g., different pole heights, lamp wattage, arms lengths). Provide each alternative with a cost estimate that includes initial cost and the annual maintenance cost.

For all LDAR components, provide sufficient detail in print format (e.g., PDF) so that reviewers do not require compatible design software to check all inputs and results of calculations.

FDM 232 (Signalization)

Commentary on Update: On 5/15/2020 by Gevin McDaniel and on 8/13/2020 by James McGinnis

Date of presentation:

- 232.1.5 – Retroreflective Signal Backplates

232.1.5 Retroreflective Signal Backplates

Install retroreflective signal backplates ~~borders~~ on traffic signals for all approaches. See TEM Section 3.12 for more information.

See TEM, Section 3.9 for use of flexible backplates where needed.

Commentary on Update: On 7/30/2020 by Bobby Bull.

Date of presentation:

- 232.6 – Pedestrian Detection and Control Signal

→ ¶
→ ¶

~~Orient push-buttons with the face parallel to the crosswalk to be used (i.e. parallel to the crossing direction).~~ See Standard Plans, Index 665-001 for additional orientation guidance. ¶

Commentary on Update: Added a new section to address APS conduit installation on 4/14/2020, modified on 4/22/2020 by Gevin McDaniel

Date of presentation: via MS Teams meeting on 4/10/2020

▪ **232.6.1 → Accessible Pedestrian Signal Feature**

Where pedestrian facilities are provided, include provisions (e.g., conduit, conductors, signal cables) needed for future use of Accessible Pedestrian Signal (APS) devices on all new and reconstructed signalized intersections and signalized midblock crossing locations.

See **TEM 3.7** for installation and operation criteria for the installation and operation of Accessible Pedestrian Signals on the State Highway System.

- 232.6.1 – Accessible Pedestrian Signal Feature

Commentary on Update: Replaced “Ten Mile Coastline Boundary” with “Mast Arm Boundary Map” on 5/14/2020

Date of presentation: via email per Lawrence Josephson on 4/3/2020

- 232.8.1 – Mast Arm Policy

232.8.1 Mast Arm Policy

Provide mast arms in accordance with the following criteria for new signals installed on the State Highway System:

- (1) Intersections within the ~~ten-mile coastline boundary~~ **Mast Arm Boundary Map**, as defined by the State Traffic Engineering Office Implementation Guidelines (aka mast arm policy area):

Signals are to be supported by galvanized mast arms, with the signal head(s) rigidly attached to the mast arm. When it is impractical to use a mast arm or overhead rigid structure within the ~~ten-mile coastline boundary~~ **Mast Arm Boundary Map**, a two point span wire assembly with adjustable hangers must be used and a Design Variation must be approved in accordance with **FDM 122**. The Department will install and maintain mast arm installations only with galvanized finish. If the Local Maintaining Agency wants a painted finish, the requesting agency is to provide the funding for the additional construction cost and be responsible for maintenance costs.

Modification for Non-Conventional Projects:

Delete the last three sentences of the above paragraph and see RFP for requirements.

- (2) Signalized Intersections outside the ~~ten-mile coastline boundary~~ **Mast Arm Boundary Map**:

Signals along all corridors outside the ~~ten-mile coastline boundary~~ **Mast Arm Boundary Map** must be supported by two-point span wire assemblies with

Commentary on Update: Added sections on 8/6/2020

Date of presentation: via email per Alexander Brum on 7/31/2020

- 232.11 – Traffic Signal System Power Design

▪ **232.11 → Traffic Signal System Power Design**

Traffic signal systems typically operate at 120 volts alternating current (AC) from the commercial utility service provider. Refer to **Section 233.3 ITS Power Design** for power source design considerations. The following subsections describe the power calculations at the traffic signal intersection.

▪ **232.11.1 → Power Load Requirements**

The total power requirement for any traffic signal system site is the sum of the power of the power of all components within the cabinet as well as all the components outside of the cabinet. requirements of the following:

Cabinet components (lights, fans, UPS, conflict monitor, power supply)

Traffic Signal Controller

Detector Cards

Traffic Signal Heads

Convenience outlets

Future equipment loads

Assume all equipment is in continuous operation.

232.11.2 Voltage Drop

Perform voltage drop calculations for the following conductors.

- 1) Conductors from the utility service provider meter to the traffic signal cabinet.
 - a. → Measure the distance between the meter and the traffic signal cabinet.
 - b. → Determine the conductor size for a maximum of 5% voltage drop.
 - c. → Voltage drop mitigation strategies may include use of larger conductors or higher service voltage.
 - d. → Minimum conductor size is 6 American Wire Gauge (AWG).
- 2) Conductors from the traffic signal cabinet to the traffic signal head.
 - a. → Measure the distance between the traffic signal cabinet and the farthest traffic signal head.
 - b. → Determine the conductor size for a maximum of 5% voltage drop.
 - c. → Voltage drop mitigation strategies may include use of larger conductors.
 - d. → Minimum conductor size is 14 AWG.

Meet Perform traffic signal system electrical design in accordance with the National Electric Code **NEC code** for traffic signal system equipment electrical designs, including voltage drop calculations, load requirements, electrical device sizing (e.g. relays, load switches, isolators, bus bars, surge protective devices), and grounding.

FDM 233 (Intelligent Transportation Systems)

Commentary on Update: Removed “to the greatest extent possible” on 4/13/2020 by Darrell Lewis

Date of presentation: 4/13/2020 via email per Benjamin Gerrell

- 233.4.1 – Conduit Infrastructure

- → Minimize road crossings. When road or ramp crossing is necessary, ~~locate and route the conduit crossing in a manner that minimizes the length to cross the road.~~ ~~place~~ Place conduit perpendicular (shortest distance) to the roadway or ramp to the greatest extent ~~possible~~ practicable. ¶

Commentary on Update: Added “backbone” on 5/4/2020

Date of presentation: 4/29/2020 via email per conversation between Bobby Bull and Derek Vollmer

- 233.5.1 – Fiber Optic Cable

233.5.1 Fiber Optic Cable

Fiber optic cable is utilized in the Department's statewide network infrastructure to provide data and device control communications between ITS field devices, Transportation Management Centers (TMCs) and other identified stakeholder facilities.

Requirements for fiber optic cable are as follows:

- Design for single mode fiber strands.
- Define fiber optic cable backbone trunk, drop buffer tube, and strand color requirements.

Commentary on Update: Made changes on 5/4/2020 by Darrell Lewis

Date of presentation: 4/6/2020 per Missy Hollis

- 233.8.1 – Managed Field Ethernet Switch (MFES) Network

233.8.1 Managed Field Ethernet Switch (MFES) Network

Provide MFES network to avoid the following:

- Distance limitations for common Ethernet media types.
- Interference that may be induced on copper-based interconnects.
- Data size transfer limitations based on Gigabit Interface Converter (GBIC).

~~Provide layer 3 routing to support the District's network architecture in leap frog configuration to provide redundancy and optimized data transfer.~~ In the fiber network layout, provide a leap-frog configuration to support availability and optimal data transfer.

Ensure no more than one DMS and no more than six CCTV devices are included on any one leap-frog circuit. Ensure that adjacent CCTV devices are on separate circuits.

~~Provide Ethernet connection ports for each planned ITS field device, along with spare capacity for future expansion. Coordinate with District ITS/TSM&O Engineer for port preferences, and data bandwidth requirements.~~

Commentary on Update: Added sections on 8/6/2020

Date of presentation: via email per Alexander Brum on 7/31/2020

- 233.8.5 – Layer 3 Switch

233.8.5 Layer 3 Switch

Within the ITS network, the Layer 3 switch provides connectivity at transmission rates of 1 or 10 Gigabit per second to and from adjacent Layer 3 switches.

The Layer 3 switch includes Layer 2 capabilities, including Quality of Service (QoS), Internet Group Management Protocol (IGMP), rate limiting, security filtering, and general management. The Layer 3 switch is fully compatible and interoperable with the ITS trunk Ethernet network interface.

The Layer 3 switch is a port-based VLAN, supporting VLAN tagging, meeting the requirements of IEEE 802.1Q standard.

The selection of a Layer 3 switch involves variables suited for the proper environment. Items such as dual power supplies, dual supervisor units, Layer 3 protocols, and voltage requirements are considered during the switch selection process. Items such as number

and type of ports are design specific. An MSP and custom pay-item are needed for all projects requiring a Layer 3 switch.

See **Form 233-A** (located in **FDM 103**) for desired Layer 3 switches.

FDM 240 (Transportation Management Plan)

Commentary on Update: Addition of the Transportation Management Plan Form to FDM 103

Date of presentation:

- 240.1 General

~~Complete the Transportation Management Plan Form, Form 240 (See **FDM-103**). This form is required for all projects (significant or not) to document compliance with the CFR 23, Part 630, Subpart J.~~

Commentary on Update: Updated Table 240.2.1 value from 1870 to 1840 on 6/10/2020.

Date of presentation:

- Table 240.2.1 Minimum Radii for Normal 0.02 Cross Slopes

Table 240.2.1 Minimum Radii for Normal 0.02 Cross Slopes

Minimum Radii for Normal Cross Slopes (Feet)									
Work Zone Speed (mph)									
25	30	35	40	45	50	55	60	65	70
290	430	610	820	1080	1390	1840	2400	3130	4090

Commentary on Update: RDB 20-04

Date of presentation:

- Table 240.2.1.5 Lane Widths

240.2.1.5 Lane Widths

See ~~Standard Plans, 102 Series~~ [Standard Specifications, Section 102](#) for lane width requirements.

Commentary on Update: On 6/5/2020 by Gevin McDaniel.

Date of presentation:

- 240.2.1.8 – Detours, Diversions, and Lane Shifts

240.2.1.8 Detours, Diversions, and Lane Shifts

Detour: a redirection of motorized and non-motorized traffic onto an alternate route, using state roads or local (county or city) roads, to bypass the work zone. ~~Requirements for detours include the following:~~

~~Detour signing must convey clear direction allowing users to safely traverse the entire detour and return to the original path of travel.~~

~~Consider the type of vehicular traffic being routed when developing a detour (e.g., vertical clearance for large vehicles). Do not route large vehicles through a U-turn.~~

~~The structural capacity of the detour pavement should also be considered.~~

~~Concurrence from the local agency is required when detours are to utilize local roadways.~~

~~Minimize interruption of local transit operations and coordinate with emergency services.~~

Diversion: a redirection of motorized and non-motorized traffic, ~~vehicular or pedestrian,~~ onto temporary pavement adjacent to the existing or permanent roadway.

Lane Shift: the redirection of motorized and non-motorized ~~vehicular~~ traffic onto a different section of the permanent roadway or shoulder.

Design detours, diversions, and lane shifts in accordance with the FDM 240.2.1.9 and the following requirements:

~~Provide sufficient detail for diversion geometry and temporary drainage in the TTCP. Show the radius of curvature and taper lengths. Cross sections which only show geometric information may be included in the TTCP for complex diversions (e.g., a special detour within a superelevated section).~~

- ~~Provide a minimum 2-foot paved shoulder when bicycle accommodations are provided elsewhere for vehicular diversions and lane shifts. Maintain existing shoulder width where practicable, but no less than:~~
 - ~~2 feet for limited access roadways or roadways with existing paved shoulders less than 4 feet, or~~
 - ~~4 feet (i.e., maintain bicycle facility) for all other roadways.~~
- For offsets to barriers and special considerations (e.g., refuge areas or emergency vehicle access), see **FDM 215**.
- ~~Provide sufficient detail for diversion geometry and temporary drainage in the TTCP. See the **FDOT Drainage Design Guide**, Temporary Drainage Chapter, for guidance. Show the radius of curvature and taper lengths. Cross sections which only show geometric information may be included in the TTCP for complex diversions (e.g., a special detour within a superelevated section).~~
- Special detours from a divided highway to an undivided condition must separate opposing traffic using either temporary barrier or temporary lane separators in accordance with the **Standard Plans**. The use of striping, RPMs, and complementary signing, either alone or in combination is not considered acceptable for separation purposes.
- ~~Minimize interruption of local transit operations and coordinate with emergency services.~~

~~In addition to the requirements above, for design detours in accordance with include the following:~~

- ~~Detour signing must convey clear direction allowing users to safely traverse the entire detour and return to the original path of travel.~~
- ~~When developing a detour, consider the type of vehicular/motorized traffic being routed when developing a detour (e.g., vertical clearance for large vehicles). Do not route large vehicles through a U-turn.~~
- ~~Consider the structural capacity of the detour pavement should also be considered.~~
- ~~Obtain concurrence from the local agency is required when detours are to utilize local roadways.~~
 - ~~Minimize interruption of local transit operations and coordinate with emergency services.~~

Commentary on Update: Updated chapter per RDB 20-01 and corrected references.

Date of presentation:

- 240.2.1.9 – Bicycle, Pedestrian, and Transit Accommodation

240.2.1.9 Bicycle, Pedestrian, and Transit Accommodation

Include accommodations for the following road users of all ages and abilities in the TTCP:

- Pedestrians
- Bicyclists
- Transit users

Provide accommodations on Florida National Scenic Trail and SUN Trail.

ADA requirements apply during TTC. Include provisions for the disabled at the same level of accessibility as the existing facility or greater. See **Standard Specifications, Section 102** and **FDM 222~~1~~, 225** for more information.

Design Principles for Temporary Bicycle and Pedestrian Facilities:

- (1) Provide like-for-like bicycle and pedestrian facilities to the maximum extent possible. When this cannot be accomplished for bicycle facilities, separate motorized traffic from bicycle traffic whenever possible. The higher the volumes of motorized traffic or percentage of truck traffic and the longer the duration of construction, the more substantial the separation should be.

Specify temporary bicycle ways that replicate the geometric characteristics of the existing bicycle way. For example, a separated bicycle facility should remain separated during construction. See **FDM 223.2.5** for more information on separated bicycle facilities.

Commentary on Update: RDB 20-04

Date of presentation: 7/30/2020 via email per Derwood Sheppard

- 240.2.1.9 Bicycle, Pedestrian, and Transit Accommodation

- (2) Phase the construction plans to ensure bicycle and pedestrian facilities are only closed when necessary. See **FDM 321** for more information on phasing.

- (3) See **Standard Plans, Index Series 102-075** for additional information and requirements on pedestrian facilities in work zones.

Commentary on Update: Edited on 8/11/2020 by Gevin McDaniel.

Date of presentation:

- 240.2.1.9 - Location of Temporary Routes for Pedestrians and Bicyclists:

(3) The order of preference for routing:

- (a) Maintain facility on the same side of the road.
 - i. Narrow the temporary bicycle way or temporary pedestrian way if needed.
 - ii. If necessary to direct non-motorists onto the roadway then:
 - ~~Provide a temporary barrier per FDM 215.~~
 - Separate motorized traffic from pedestrians.
 - a. Provide a temporary barrier per FDM 215 where pedestrians are shifted adjacent to traffic lanes.
 - Consider closing one lane of motorized traffic to accommodate non-motorized traffic of bicycle or pedestrian facilities with high usership.
 - iii. If the existing bicycle facility is a shared use path or separated bike lane and separation for bicyclists, such as a temporary bike lane, is not possible, then bicyclists may be directed onto a temporary or permanent pedestrian way of a minimum width of 8 feet.

Commentary on Update: Edited on 7/13/2020 by Darrell Lewis.

Date of presentation:

- 240.2.1.9 - Location of Temporary Routes for Pedestrians and Bicyclists:

- (b) Diversion to the opposite side of the road. Return to original side of road as soon as possible.
 - i. Phase the construction so bicycle or pedestrian facilities will be open on the other side of the road if facilities cannot be provided on the same side of the road.
 - ii. ~~Choose crossing points with adequate stopping sight distance.~~
 - ii. If using temporary midblock crossings, then consider the use of temporary traffic signals or RRFBs. See FDM 240.2.2.8 and the TEM for more information.
 - iii. ~~_____~~
 - iii.iv. ~~_____~~ Warn motorized and non-motorized traffic there are extra pedestrian or bicycle crossings through portable changeable message signs (PCMS) per **FDM 243**. For example:

Commentary on Update: RDB 20-04

Date of presentation: 7/30/2020 via email per Derwood Sheppard

- 240.2.1.13 – Roadside Hazards

240.2.1.13 Roadside Hazards

See **FDM 215** and [Standard Plans, Index-102 Series-100](#) for information on the shielding of roadside hazards.

Commentary on Update: Per RDB 20-04

Date of presentation: 7/30/2020 via email per Derwood Sheppard

- 240.2.1.14 – Drops-Offs in Work Zones

240.2.1.14 Drop-offs in Work Zones

See [Standard Plans, Index-102 Series-000](#) for requirements related to drop-offs in work zones.

Commentary on Update: Revisions per RDB 20-01

Date of presentation:

- 240.2.2.1– Signs

240.2.2.1 Signs

The following types of signs are encountered in temporary traffic control:

- Work Zone Signs
- ~~Project Information Signs~~
- Existing Signs

Commentary on Update: Revisions per RDB 20-04

Date of presentation: 7/30/2020 via email per Derwood Sheppard

- 240.2.2.1 – Signs

Work Zone Signs

Work zone signs are typically post mounted in accordance with [Standard Plans, 102 Series-000](#).

Commentary on Update: Revisions per RDB 20-01

Date of presentation:

- 240.2.2.1– Signs

See the [Standard Plans, 102 Series](#) for required work zone signs and placement.

Project Information Signs

The project information sign is required for all projects with a construction contract time of more than 730 days. Placed only on the mainline approaches, this sign is typically located 500 feet in advance of the first advance warning sign, or as close to the beginning of the project as practical. This sign may be omitted if physical constraints prohibit safe placement.

Project information sign details are shown in [Standard Plans, Index 102-000](#). Provide in the TTCP the information to be used on the sign; SR # (e.g., I-10, SR 5, US 1), completion date and the project website, or the phone number of the district office responsible to answer project specific questions. |

Existing Signs

Specify covering, removing, or relocating existing regulatory or warning signs that conflict with the TTCP, or to complement the work zone conditions (e.g., if a stop sign on an existing side road is needed, use the existing sign and show the location that it is to be relocated to).

Modify existing guide signs to show changes made necessary by the construction operations. If existing guide signs are to be removed during construction, make provisions for temporary guide signing. The temporary sign should be black on orange with the legend designed in accordance with **MUTCD** requirements for permanent guide signing.

Commentary on Update: RDB 20-04

Date of presentation: 7/30/2020 via email per Derwood Sheppard

- 240.2.2.3 – Temporary Raised Pavement Markers

240.2.2.3 Temporary Raised Pavement Markers

Temporary Raised Pavement Markers (RPMs) are used to supplement work zone pavement markings in accordance with [Standard Plans, Index 102 Series-000](#) and [Standard Specifications, Section 102](#).

Commentary on Update: RDB 20-04

Date of presentation: 7/30/2020 via email per Derwood Sheppard

- 240.2.2.5 – Pedestrian Longitudinal Channelizing Devices

240.2.2.5 Pedestrian Longitudinal Channelizing Devices

Specify the use of pedestrian Longitudinal Channelizing Devices (LCDs) for the following situations:

- At each closed pedestrian way location, for the full width of the pedestrian way
- In locations where a drop-off hazard exists (see [Standard Plans, Index 102 Series-000](#))

Commentary on Update: On 8/13/2020 by James McGinnis.

Date of presentation:

- 240.2.2.5 – Pedestrian Longitudinal Channelizing Devices

- Along both sides of a temporary pedestrian way
 - ~~Pedestrian LCDs are not required on sides where~~When an existing or temporary barrier delineates ~~one or both sides of a the~~ temporary pedestrian way, ~~pedestrian LCDs are not required.~~

Commentary on Update: On 8/13/2020 by James McGinnis per RDB 20-04.

Date of presentation:

- 240.2.2.13 – Temporary Raised Rumble Strips

240.2.2.13 Temporary Raised Rumble Strips

Temporary raised rumble strips are used to warn vehicular traffic of the upcoming work zone. Specify the use of temporary raised rumble strips when both of the following conditions occur:

- Lane closure on a two-lane, two-way roadway
- Existing posted speed prior to construction is 55 mph or greater

~~Optionally, specify the use of temporary raised rumble strips when both of the following conditions occur:~~

- ~~• Lane closure on a multilane roadway~~
- ~~• Existing posted speed prior to construction is 55 mph or greater~~

~~Do not use temporary raised rumble strips on Limited Access facilities.~~

~~See [Standard Plans, Index 102 Series-000](#) for temporary raised rumble strip details.~~

Commentary on Update: RDB 20-04

Date of presentation: 7/30/2020 via email per Derwood Sheppard

- 240.2.2.14 – Temporary Lane Separator

240.2.2.14 Temporary Lane Separator

Temporary lane separator should be used to separate opposing traffic on previously divided roadways with a work zone speed of 45 mph or less.

See [Standard Plans, Index 102 Series-000](#) for temporary lane separator details.

Commentary on Update: RDB 20-04

Date of presentation: 7/30/2020 via email per Derwood Sheppard

- 240.2.2.15 – Temporary Highway Lighting

(b) Do not locate structural supports for temporary lighting on the back side of permanent or temporary barriers/traffic railings; i.e., which face away from traffic, where the back side of the barriers/traffic railings are within the work zone clear zone (per [Standard Plans, Index 102 Series-000](#)) of other traffic lanes.

(h) For structural supports attached to and located behind [Standard Plans, Index 102 Series-110](#) (Type K Temporary Concrete Barriers), provide a minimum setback distance of 1'-6" from the top edge of the traffic face of the barrier to the traffic face of the luminaire pole. To minimize the potential for damaging reinforcing steel during the installation of the anchors, attach brackets within the middle portion, where there is large spacing between the vertical steel reinforcing bars, of the Type K Barrier Unit.

Commentary on Update: Updated text on 7/29/2020 the Structures Office

Date of presentation: 7/2/2020 per Cheryl Hudson via email

- Table 240.2.2.18 Temporary ACROW Bridge

240.2.2.18 Temporary ACROW Bridge

When using a temporary ACROW bridge, include "Legal Weight Only" sign in accordance with [Standard Plans, Index 700-102](#) and [Index 700-107](#). Specify "Slippery When Wet" (W8-5) signs in advance of all temporary ACROW bridges **when an asphalt overlay is not used**. See [Standard Plans, 102 Series](#) and the associated [Standard Plans Instructions \(SPI 102-200 for the 300 Series and 102-201 for the 700 Series\)](#) for more information.

For limited access facilities, the ACROW Series 700 bridging must be used. All temporary bridges require with a project-specific foundation design. Contact the State Maintenance Office for additional information.

FDM 243 (Portable Changeable Message Signs)

Commentary on Update: Edited on 5/8/2020 by Darrell Lewis

Date of presentation:

- 243.2 –PCMS Placement

▲ 243.2 PCMS Placement

The message displayed must be visible and legible unobstructed to a motorist in accordance with **Standard Specification 102**. The message displayed must be visible and legible to a motorist installed at the following minimum distances:

Commentary on Update: Added "PED", "XING" and "XWALK" to abbreviation list on 4/8/2020

Date of presentation: 7/23/2019 via email per Mary O'Brien

- 243.3.1 – Standard Abbreviations for Use on PCMS

STANDARD ABBREVIATIONS FOR USE ON PCMS			
Standard abbreviations easily understood are:			
<u>WORD</u>	<u>ABBREV.</u>	<u>WORD</u>	<u>ABBREV.</u>
Boulevard	BLVD	Normal	NORM
Center	CNTR	Parking	PKING
Crossing	XING	Pedestrian	PED
Crosswalk	XWALK	Road	RD
Emergency	EMER	Service Road	SERV RD
Entrance, Enter	ENT	Shoulder Service	SHLDR SERV
Expressway	EXPWY	Slippery Shoulder	SLIP SHLDR
Freeway	FRWY, FWY	Speed Slippery	SPD SLIP
Highway	HWY	Traffic Speed	TRAF SPD
Information	INFO	Travelers Traffic	TRVLRS TRAF
Left	LFT	Warning Travelers	WARN TRVLRS
Maintenance	MAINT	Warning	WARN

FDM 260 (Bridge Structures)

- *Commentary on Update: Updated Figure 260.1.4- Revised bike lane width from 7' to 8.4'*
- *Date of presentation:*

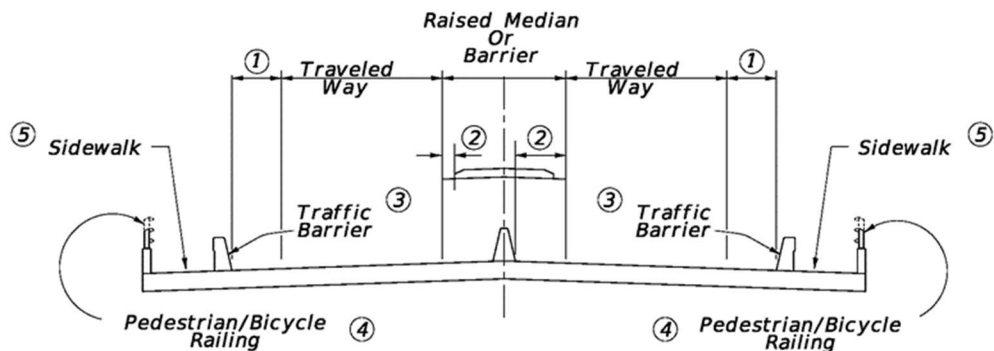

- ① **Outside shoulders:**
Curbing on approach roadway:
 Use 2.5' minimum, 8'-4" with bike lane, 8' minimum for bridges 500' or longer or high-level bridges.
Flush shoulder on approach roadway:
 Use 10' minimum.
- ② **Median shoulders:**
Raised median on bridge:
 Use same offset to median as used on the approach roadway.
Median barrier on bridge:
Raised median on approach roadway:
 Use 2.5' minimum, and for bridges 500' or longer or high-level bridges use 6' minimum for 2 lanes and 8' minimum for 3 or more lanes.
Flush shoulder on approach roadway:
 Use 6' minimum for 2 lanes and 10' minimum for 3 or more lanes.
- ③ *Use traffic barrier between traveled way and sidewalk and separate pedestrian railing at back of sidewalk if heavy pedestrian traffic is anticipated or facility is near a school, or design speeds on the bridge are 50 mph or greater.*
- ④ *Provide pedestrian/bicycle railing as required per FDM 222.4*
- ⑤ *See FDM 260.2.2 for sidewalk width requirements.*

FDM 261 (Structural Supports for Signs, Signals, Lighting, and ITS)

Commentary on Update: Changed "Working" to "Shop" on 7/8/2020 by Bobby Bull.

Date of presentation:

- 261.1 – General

When a custom support structure is required, or otherwise specifically designated in the contract documents, the Engineer of Record (EOR) is responsible for the structural design including foundations and the review of the Working shop Drawings. Details for supports attached to bridge structures must be coordinated with the bridge structural engineer and included in the plans. See Structures Design Guidelines, Section 1.9 for details and restrictions related to making attachments to bridges.

- 261.2 – Sign Support Structures

The EOR is responsible for the design of all multi-column ground signs and overhead sign structures (including bridge mounted signs). This responsibility is for the entire sign structure, including the supports and foundations, as well as all details necessary to fabricate and erect the sign structures. The EOR is also responsible for the working shop drawing review in accordance with **FDM 267** when sign structure working shop drawings are required by the Contract Documents.

- 261.7 – Evaluating Existing Sign, Signal, Lighting and ITS Support Structures

Analytical Evaluation:

A structural capacity analysis ranging from the review of structural plans, design calculations and working shop drawings (if available) to a detailed structural analysis. Contact the District Structures Design Office for guidance on the extent of analysis required and for guidance on analyzing existing ancillary structures without plans, working shop drawings, foundation depths, or design calculations.

FDM 263 (Geosynthetic Design)

Commentary on Update: Changed "Working" to "Shop" on 7/8/2020 by Bobby Bull.

Date of presentation:

- 263.3 – Shop Drawings and Redesigns

263.3 Working Shop Drawings and Redesigns

The working shop drawing reviewer must be familiar with the requirements, design and detailing of these systems. The review must consist of but not limited to the following items:

FDM 265 (Reinforced Concrete Box and Three-Sided Culverts)

Commentary on Update: Changed "Working" to "Shop" on 7/8/2020 by Bobby Bull.

Date of presentation:

- 265.14 – Design and Shop Drawing Approvals

265.14 Design and ~~Working~~ Shop Drawing Approvals

Modification for Non-Conventional Projects:

Delete **FDM 265.14** and see RFP for ~~Working Shop~~ Drawing ~~Shop~~ Approval requirements.

FDM 266 (Bicycle and Pedestrian Bridges)

Commentary on Update: Changed "Working" to "Shop" on 7/8/2020 by Bobby Bull.

Date of presentation:

- 266.3.3 – Plans Development

- ~~Working~~ Shop Drawing Submittal

Prior to fabrication the Contractor's EOR must submit signed and sealed superstructure ~~working shop~~ drawings, technical specifications, and design calculations to the Engineer for review and approval.

Commentary on Update: On 9/4/2020 by Bobby Bull.

Date of presentation:

- 266.3.3 – Plans Development

~~(8) — Include the following Pay Item note in the plans:~~

- ~~Prefabricated Steel Truss Pedestrian Bridge Span~~

~~Prefabricated Steel Truss Pedestrian Bridge Span will be paid for at the contract unit price per square foot of deck area under Pay Item No. 460-7 Prefabricated Steel Truss Pedestrian Bridge, SF. This pay item includes furnishing and installing the prefabricated steel truss pedestrian bridge superstructure including steel trusses, floor system, deck, bearing assemblies, deck joints, and bridge railing/fencing. Payment for this pay item is based on the plan quantity. Portions of pedestrian bridge outside the limits of the steel truss span are paid for under individual pay items.~~

FDM 267 (Shop Drawing Submittals)

Commentary on Update: On 8/7/2020 made changes from email to reference the Specifications for the definitions.

Date of presentation: 8/3/2020 via email per Scott Arnold

267 ~~Working~~ Shop Drawing Submittals

267.1 Introduction

While the Contract Plans and Specifications (including Supplemental and Special Provisions) define the overall nature of the project, ~~Working~~ Shop Drawing submittal is the accepted method of approving a specific element of the work while allowing flexibility in the Contractor's means and methods. The Contract Plans and Special Provisions for the project are to identify the requirements for submittal of ~~Working~~ Shop Drawings.

~~Working~~ Shop Drawing submittals must meet or exceed the quality level of previously approved submittals of a similar nature and be complete enough to allow for fabrication of an item without referencing any other document.

A Shop Drawing submittal for structural bridge components (e.g., steel girders, non-standard precast/prestressed beams) typically include plan and elevation views denoting the placement of a component in the structure.

Unless explicitly stated, definitions shown referencing the Standard Specifications are the same for the Design-Build Division I Specifications:

- (1) ~~**Working Shop Drawings:** See Specifications~~ **All shop and erection drawings, erection manuals, geometry control manuals, associated trade literature, calculations, schedules, manuals and similar documents submitted by the Contractor to define some portion of the project work. The type of work includes both permanent and temporary works as appropriate to the project.**
- (2) ~~**Engineer:** See Specifications~~ **The Director, Office of Construction, acting directly or through duly authorized representatives; such representatives acting within the scope of the duties and authority assigned to them.**
- (3) ~~**Engineer of Record (EOR):** See Specifications~~ **The Professional Engineer or Engineering Firm registered in the State of Florida that develops the criteria and concept for the project, performs the analysis, and is responsible for the preparation of the Plans and Specifications. The Engineer of Record may be Departmental in-house staff or a consultant retained by the Department.**

- 267.1 - Introduction

Modification for Non-Conventional Projects:

Delete **Engineer of Record (EOR)** definition and replace with the following:

(3) **Engineer of Record (EOR):** ~~See Design-Build Specifications~~The Professional Engineer or Engineering Firm registered in the State of Florida that develops the criteria and concept for the project, performs the analysis, and is responsible for the preparation of the Technical Proposal, Division II and III Specifications, Plans, and other documents as required by the Request for Proposal. The EOR must be a part of the Design-Build Firm.

- (4) **Contractor's Engineer of Record:** ~~See Specifications~~A Professional Engineer registered in the State of Florida, other than the Engineer of Record or his subcontracted consultant, who undertakes the design and drawing of components of the permanent structure as part of a redesign or Cost Savings Initiative Proposal, or for repair designs and details of the permanent work. The Contractor's Engineer of Record may also serve as the Specialty Engineer.
- (5) **Specialty Engineer:** ~~See Specifications~~A Professional Engineer registered in the State of Florida, other than the Engineer of Record or his subcontracted consultant, who undertakes the design and drawing preparation of components, systems, or installation methods and equipment for specific temporary portions of the project work or for special items of the permanent works not fully detailed in the Plans and required to be furnished by the Contractor; e.g., pot bearing designs, nonstandard expansion joints, MSE wall designs.

- (8) **"Ballooning"**: The Contractor's use of minimum 1/16 inch wide lines to "balloon" or "cloud" (encircle) notes or details on drawings, and design calculations, in order to explicitly and prominently call out any deviations from the Contract Plans or Specifications. The EOR may also use "ballooning" to make note of any limitations to their submittal review and disposition of Working-Shop Drawings.
- (9) **Record Working-Shop Drawings**: The Department's official record copy of all Working-Shop Drawings, correspondence/ transmittal files and submittal activity record (logbook).
- (10) **FDOT Working-Shop Drawing Review Office**: The office or other Department entity responsible for performing the Department's review, record keeping, disposition and distribution of Working-Shop Drawings to other disciplines within the district for review as well as distribution back to the project personnel. This office is normally the District Structures Design Office.
- (11) **Final Review Office**: FDOT Working-Shop Drawing Review Office or the EOR performing the final review and making final distribution of working-shop drawings which have been reviewed.
- (12) **Bridge Demolition of Bridges with Continuous Beams or Girders Affecting Public Safety**: See Specifications Where traffic is placed under one or more spans of the continuous unit being demolished.
- ~~(13) **Critical Temporary Construction Works Affecting Public Safety**: See Specifications Any temporary construction works necessary for the construction of the permanent structure (e.g. bracing, falsework, formwork, scaffolding, shoring) in which traffic is being placed under, on, or adjacent to span(s) being supported by the temporary works are deemed to be critical. Any temporary construction works necessary for the construction of the permanent works (e.g., temporary earthworks, sheeting, or cofferdams) in which traffic being placed near or on the temporary works are deemed to be critical. All temporary works utilized to support partially constructed/demolished structures affecting public safety are deemed to be critical.~~
- ~~(14) Temporary Works does not include:~~
- ~~(15) Formwork complying with Standard Plans, Index 102-600 (concrete placement is not permitted directly over traffic).~~
- ~~(16) Critical temporary walls that are fully detailed in the plans unless redesigned by the Contractor.~~
- ~~(17)(13) Specialized equipment if traffic is removed from under equipment while equipment is being loaded, launched, and while loads are being transported by equipment.~~

Modification for Non-Conventional Projects:
Expand the list above with the following:
(14) Design-Build Firm: <u>See Design-Build Specifications</u> Any company, firm, partnership, corporation, association, joint venture, or other legal entity permitted by law to practice engineering, architecture, and construction contracting, as appropriate, in the State of Florida.

Commentary on Update: Changed "Working" to "Shop" on 7/8/2020 by Bobby Bull.

Date of presentation:

- 267.3 – Contractor Information Required

267.3 Contractor Information Required
A <u>Working Shop</u> Drawing submittal that omits any of the minimum requirements listed in <u>Standard Specifications, Section 5-1.4.6.1</u> must be returned for resubmittal.
Modification for Non-Conventional Projects:
Delete FDM 267.3 and see RFP for <u>Working Shop</u> Drawing requirements.

Commentary on Update: Changed "Working" to "Shop" on 7/8/2020 by Bobby Bull.

Date of presentation:

- 267.4 – Submittals Requiring a Specialty Engineer or Contractor’s Engineer of Record

267.4 Submittals Requiring a Specialty Engineer or Contractor’s Engineer of Record
When required, the Specialty Engineer or Contractor’s Engineer of Record must provide a signed and sealed <u>Working Shop</u> Drawing submittal. The signed and sealed <u>Working Shop</u> Drawings will be retained by the Department as the official, Record <u>Working Shop</u> Drawing.
Signed and sealed <u>Working Shop</u> Drawing submittals by a Specialty Engineer or Contractor’s Engineer of Record typically include signed and sealed drawings and calculations.

Commentary on Update: Changed "Working" to "Shop" on 7/8/2020 by Bobby Bull.

Date of presentation:

- 267.5 – Transmittal of Submittals

267.5 Transmittal of Submittals

Submittal of ~~Working-Shop~~ Drawings must be made by the project Contractor to the designated parties, as applicable. Submittals will not be accepted from a subcontractor or fabricator. Subcontractors and fabricators are encouraged to contact the appropriate FDOT ~~Shop-Working~~ Drawing Review Office for guidance.

Figures 267.11.1 thru **267.11.3** shown in **FDM 267.11** illustrate the flow of submittals during the review process. Use electronic delivery to transmit submittals between parties.

Modification for Non-Conventional Projects:

Delete the above paragraph and replace with the following:

Figure 267.11.4 shows the flow of critical temporary works ~~working-shop~~ drawings affecting public safety including erection manuals and erection plans. **Figure 267.11.4** also shows the flow of demolition plans of a bridge with continuous beams or girders where one span within the unit is over traffic. Use electronic delivery to transmit submittals between parties.

Figure 267.11. 5 shows the flow of all other ~~working-shop~~ drawing submittals. Use electronic delivery to transmit submittals between parties.

See RFP for transmittal and submittal review requirements.

Commentary on Update: Changed "Working" to "Shop" on 7/8/2020 by Bobby Bull.

Date of presentation:

- 267.5.1 – Requirements for Department EOR

On projects where the EOR is Department in-house staff, transmit submittals to the FDOT Shop Drawing Review Office or as directed at the project's preconstruction conference. The FDOT Shop Drawing Review Office is the principal contact group and "clearing house" for all construction submittals and information desired by the Contractor regarding structural, mechanical or electrical items.

The EOR must perform a thorough review of the ~~working-shop~~ drawings, implement a QA/QC Plan, provide a QA/QC check print to the Department, and ensure that all

components depicted in the working-shop drawings are being constructed/fabricated in accordance with the RFC Plans and other Contract Documents. The working-shop drawing stamp (e.g., "APPROVED" or "APPROVED AS NOTED") must include language that states that the working-shop drawing was reviewed in accordance with **FDM 267** and with the Contract.

Modification for Non-Conventional Projects:

Delete **FDM 267.5.1** and replace with the following:

267.5.1 Review Requirements for EOR

The EOR must perform a thorough review of the working-shop drawings, implement a QA/QC Plan, provide a QA/QC check print to the Department, and ensure that all components depicted in the working-shop drawings are being constructed/fabricated in accordance with the RFC Plans and other Contract Documents. The working-shop drawing stamp (e.g. "APPROVED" or "APPROVED AS NOTED") must include language that states that the working-shop drawing was reviewed in accordance with **FDM 267** and with the Contract.

Commentary on Update: Changed "Working" to "Shop" on 7/8/2020 by Bobby Bull.

Date of presentation:

- 267.5.2.1 – Review by Engineer of Record Only

267.5.2.1 Review by Engineer of Record Only

I
On projects where the EOR is a Consultant to the Department and has been retained by the Department to review construction items without follow-up review by the Department, the Consultant will assume the responsibility of the owner's agent. The reviewing consultant is encouraged to communicate with fabricators, contractors, specialty engineers and the FDOT Shop Drawing Review Office to clarify concerns before returning the submittal to the Contractor. The reviewing consultant must also contact the Department's Structures Office if unsure of the Department's position on certain issues during the review. Where possible, mark all necessary requirements on the working-shop drawing sheet and stamp "APPROVED AS NOTED" instead of requiring a resubmittal. The Contractor will transmit the submittals directly to the Consultant (unless otherwise noted below). Upon receipt of the submittal, the Consultant must perform the review, note any comments on the sheets, indicate his disposition by stamping the sheets as described hereinafter and make distribution as described hereinafter. The original submittal forms the official Record Working-Shop Drawing submittal and must be sent by the EOR to the Department at the end of the project.

Commentary on Update: Changed “Working” to “Shop” on 7/8/2020 by Bobby Bull.

Date of presentation:

- 267.5.2.2 – Review by Engineer of Record and the Department

267.5.2.2 Review by Engineer of Record and the Department

On projects where the EOR is a Consultant to the Department and has been retained by the Department to review construction items, submittals (unless otherwise noted below) must be transmitted by the Contractor directly to the Consultant. Upon receipt of the submittal, the Consultant must perform the review, note any comments on the sheets, indicate his disposition by stamping the sheets as described hereinafter, and transmit the sheets to the FDOT Shop Drawing Review Office for review and distribution. When submittals require a Specialty Engineer, the original submittal forms the official, Record ~~Working~~ Shop Drawing submittal and must be retained by the Department. Upon completion of his review, the Consultant must transfer his comments to the sealed sheets, indicate his disposition and transmit them to the Department as described above.

Modification for Non-Conventional Projects:

Delete **FDM 267.5.2** and replace with the following:

267.5.2 Review Requirements for ~~WorkingShop~~—_Drawings Affecting Public Safety

The EOR must perform a thorough review of the ~~working-shop~~ drawings, implement a QA/QC Plan, provide a QA/QC check print to the Department, and ensure that all components depicted in the ~~working-shop~~ drawing are being constructed, fabricated, or demolished in accordance with the RFC Plans and other Contract Documents.

An Independent Peer Review must be performed for all critical temporary works ~~working-shop~~ drawings, erection manuals, and erection plans affecting public safety. This includes demolition plans of a bridge with continuous beams or girders where one span within the unit is over traffic. This review is a comprehensive independent verification of the design of the structural elements depicted in the ~~working-shop~~ drawing. The Independent Peer Review cannot be performed by the originator of the ~~working-shop~~ drawing, and must be completed by either the EOR or by an Independent Peer Reviewer. The Independent Peer Review must follow one of the processes below (depending on who performs the Review):

- The EOR performs the Independent Peer Review: The EOR will apply the ~~working-shop~~ drawing stamp (e.g., "APPROVED" or "APPROVED AS NOTED") and must include a signed and sealed certification letter stating that an Independent Peer Review was performed in accordance with **FDM 267** and with the Contract. The certification letter must clearly state which components (e.g., temporary works) were reviewed.
- An Independent Peer Reviewer performs the Independent Peer Review: The EOR will apply the ~~working-shop~~ drawing stamp (e.g., "APPROVED" or "APPROVED AS NOTED") and include a statement that the ~~working-shop~~ drawing was reviewed in accordance with **FDM 267** and with the Contract, but an Independent Peer Review was not performed. Then, an Independent Peer Reviewer qualified under **Florida Administrative Code, Rule 14-75** (in the Work Group for the structure being constructed, fabricated, or demolished) must perform the Independent Peer Review. The Independent Peer Reviewer must sign and seal a certification letter stating that an Independent Peer Review was performed in accordance with **FDM 267** and with the Contract. The certification

Commentary on Update: Changed "Working" to "Shop" on 7/8/2020 by Bobby Bull.

Date of presentation:

- 267.6 – Disposition of Submittals

Modification for Non-Conventional Projects:

Delete the above paragraph and replace with the following:

The approval or disapproval of submittals by the EOR must be indicated by one of the following designations: "APPROVED" (no further action required), "APPROVED AS NOTED" (make corrections noted - no further submittal required), "RESUBMIT" (make corrections noted and resubmit for approval), or "NOT APPROVED" (rejected - do not resubmit the concept or component as submitted). Only working-shop drawings that have been "APPROVED", or "APPROVED AS NOTED" must be submitted to the Department for review. Submit copies of QA/QC working-shop drawing check prints to the CEI along with the working-shop drawing.

The Department must stamp the drawings "RELEASE FOR CONSTRUCTION", "RELEASE FOR CONSTRUCTION AS NOTED", OR "RESUBMIT". Where possible, mark all necessary requirements on the working-shop drawing sheet and stamp "RELEASE FOR CONSTRUCTION AS NOTED" instead of requiring a resubmittal.

Disposition of Working-Shop Drawing submittals by the EOR for construction and erection equipment including beams and winches, launch gantry, erection trusses, forms, falsework, midspan and longitudinal closures, lifting devices, temporary bearing fixity devices, cranes, form travelers, segment carrying equipment and stability devices must be either "NOT APPROVED" if deemed to be unacceptable or, if acceptable, must be "APPROVED AS NOTED" with the following note included on the submittal drawings:

On projects when the EOR is a Consultant to the Department and the Department will also be reviewing working-shop drawings, the Department will perform a second confirmation review of the submittal. Upon receipt of the Consultant's reviewed submittal, the Department will stamp the submittal with the disposition as noted above. The primary purposes of the Department's review include: conformance with FDOT policy and standards; uniformity of disposition with similar submittals; accuracy and completeness of the Consultant's review; and attention to specific details or areas of work that have experienced recurring problems during fabrication or construction.

(2) The Working-Shop Drawings are correctly signed and sealed by the Specialty Engineer or Contractor's Engineer of Record.

Figures 267.11.1 through **267.11.3** shown in **FDM 267.11** illustrate the submittal and distributional flow of a working-shop drawing transmittal. When the Department concurs with the Consultant's review and disposition of the submittal, the Department will stamp and distribute the submittal including a record copy for the Consultant.

Modification for Non-Conventional Projects:

Delete the above paragraph and replace with the following:

Figures 267.11.4 and **267.11.5** show the submittal and distributional flow of a working shop drawing transmittal. When the Department concurs with the Design-Build Firm's EOR review and disposition of the submittal, the Department will stamp and distribute the submittal.

Commentary Update: Changed "Working" to "Shop" on 7/8/2020 by Bobby Bull.

Date of on presentation:

- 267.6.1 – Minor Modifications

In this event, the Department will notify the Consultant of the modifications, document the notification in the project's working-shop drawing file, process and distribute the submittal and furnish the Consultant with a copy.

Modification for Non-Conventional Projects:

Delete **FDM 267.6.1** and replace with the following:

267.6.1 Minor Modifications

The submittal will be processed when notations not involving design decisions are added, modified or deleted and when the disposition of the submittal remains unchanged or changed only in accordance with the following **Table 267.6.1**:

Table 267.6.1 FDOT Changes to Minor Modifications

From	To
Approved	Released for Construction as Noted
Approved as Noted	Released for Construction

In this event, the Department will notify the Design-Build Firm of the modifications, document the notification in the project's working-shop drawing file, process and furnish the Design-Build Firm with a copy.

Commentary on Update: Changed "Working" to "Shop" on 7/8/2020 by Bobby Bull.

Date of presentation:

- 267.7 – Distribution of Submittals

267.7 Distribution of Submittals

Figures 267.11.1 thru **267.11.3** shown in **FDM 267.11** illustrate the submittal and distributional flow of ~~working-shop~~ drawings for reviews performed by Consultant EORs without FDOT review, reviews performed by Consultant EOR with FDOT review, and reviews performed by FDOT only. In the case of reviews performed by Consultant EORs and FDOT, the Consultant must transmit ~~Working-Shop~~ Drawings to the appropriate FDOT Shop Drawing Review Office.

When precast/prestressed concrete components are involved, copies of the Shop Drawings are to be submitted to the Department's District Prestress Engineer and the State Materials Office (Gainesville). When structural steel components are involved, copies of the Shop Drawings are to be submitted to the Department's Verification Inspection Consultant.

When the Department is reviewing ~~working-shop~~ drawings and a submittal is denied ("RESUBMIT" or "NOT APPROVED"), distribution of the submittal must be made to the FDOT Shop Drawing Review Office's File and the Contractor only, with a copy of the transmittal letter to the Engineer (CEI).

Modification for Non-Conventional Projects:

Delete **FDM 267.7** and replace with the following.

267.7 Distribution of Submittals

Figure 267.11.4 shows the submittal and ~~working-shop~~ drawing flow diagram for design-build projects. The Contractor submits ~~Working-Shop~~ Drawings to the Engineer (CEI).

Commentary on Update: Changed “Working” to “Shop” on 7/8/2020 by Bobby Bull.

Date of presentation:

- 267.8 – Review of Prequalified Joint Welding Procedures

267.8 Review of Prequalified Joint Welding Procedures

In accordance with **Section 11.2** of the [Materials Manual](#), the approval of all joint welding procedures specification (WPS) will be the responsibility of the Department's Verification Inspection Consultant. The State Materials Office maintains the list of the approved WPS which may be used on all future projects by the fabricator who developed them, until their expiration. A list of the approved WPSs will be provided with the submittal of the [Working Shop Drawings](#). The EOR may elect to review these documents. [Working Shop](#) drawings depicting plate sizes, types of welds, weld designations, weld sizes and grades of materials will continue to be reviewed by the EOR.

Commentary on Update: Changed “Working” to “Shop” on 7/8/2020 by Bobby Bull.

Date of presentation:

- 267.9 – Submittal Activity Record (Logbook)

267.9 Submittal Activity Record (Logbook)

The Final Review Office is responsible for maintaining a Submittal Activity Record (Logbook) on each project reviewed by the office. Update the logbook each day that any [Working Shop](#) Drawing submittal activity occurs. Enter the following minimum data in the logbook for each submittal:

Commentary on Update: Changed "Working" to "Shop" on 7/8/2020 by Bobby Bull.

Date of presentation:

- 267.10 – Archiving Record Shop Drawings

267.10 Archiving Record ~~Working~~ Shop Drawings

Upon completion and acceptance of a construction project by the Department (usually by receipt of a written Notice of Acceptance), the Final Review Office, within thirty (30) days, will transmit the Record ~~Working~~ Shop Drawings to the appropriate offices, as dictated by practice in the District in which the project is located. The Record ~~Working~~ Shop Drawings may include some or all of the following documents:

- (1) ~~Working~~ Shop Drawings (including all relevant data as set forth in the Specifications)
- (2) Project Files of ~~Working~~ Shop Drawing transmittal letters.
- (3) Submittal Activity Record

The Final Review Office must complete the Record ~~Working~~ Shop Drawing Transmittal (see **Form 267-A**, located in **FDM 103**), and transmit copies, along with the Record ~~Working~~ Shop Drawings described above, to the appropriate office. The Record ~~Working~~ Shop Drawing Transmittal describes all the Record ~~Working~~ Shop Drawing documents being transmitted.

The Submittal Activity Record (logbook) is intended to serve as the listing of all ~~Working~~ Shop Drawings transmitted. Other transmitted material such as project files and samples should be listed individually on the Transmittal shown in **Form 267-A**.

Upon receipt of the Record ~~Working~~ Shop Drawings, the offices receiving the transmittal will verify the documents and material transmitted, sign and date the Record ~~Working~~ Shop Drawing Transmittal, and return a copy to the Final Review Office.

The Final Review Office will maintain a file of Record ~~Working~~ Shop Drawing Transmittals (**Form 267-A**) for future reference and use. Once the signed copy of the Record ~~Working~~ Shop Drawing Transmittal is received, the Final Review Office's initially retained Record ~~Working~~ Shop Drawing Transmittal may be discarded.

Commentary on Update: Changed "Working" to "Shop" on 7/8/2020 by Bobby Bull.

Date of presentation:

- 267.11 – Shop Drawing Flow Diagrams

267.11 ~~Working~~ Shop Drawing Flow Diagrams

Figures 267.11.1 through **267.11.5** show the submittal and distributional flow of ~~working~~ shop drawings for reviews.

FDM 301 (Sequence of Plans Preparation)

Commentary on Update: On 8/26/2020 by James McGinnis

Date of presentation:

- 301.1 – General

Coordinate Specifications and Estimates in accordance with the plans review phases in **Table 301.2.1**.

Table 301.2.1 → Summary of Phase Submittals

	Phase				
	I	II	III	IV	PS&E "Final Submittal" Phase
Plans	FDM-301.2.1	FDM-301.2.2	FDM-301.2.3	FDM-301.2.4	FDM-301.2.5
Specifications per Specifications Handbook	x	Identify Specs; draft TSP, MSP, or DevSpec as needed	Submit TSP or MSP for Technical and Legal review(s)	Prepare Specification package with latest e-book and workbook	Finalize Specifications package
		Complete Sole-Source Approvals as needed	Ensure specifications work with APL, IPL, or sole-source items	x	x
Estimates per Basis of Estimates	x	Load pay items per BOE Chapter-9 ; request pay items per BOE Chapter-6 ; based on TSP or MSP's identified	Load quantities for all pay items; per BOE Chapter-8	Update quantities based on final plans	Final
		Summary of Pay Items Report	Estimated Quantities Report	Estimated Quantities Report	Estimated Quantities Report
Cost Estimates by District Estimator	Completed prior to next phase submittal	Completed prior to next phase submittal	Completed prior to next phase submittal	Authorization Estimate Completed prior to XXX	Authorization Estimate & Official Estimate

Topic #625-000-002
FDOT Design Manual

General descriptions of the required levels of completion that are noted in **Table 301.2.4-2** are as follows:

- (1) Preliminary (P): Basic shapes, geometry, and information are shown to adequately convey the concept.
- (2) Complete but Subject to Change (C): The design, drawings and details are complete. Only reviewer-initiated changes should be expected at this level.
- (3) Final (F): All drawings and designs are complete. No changes are expected at this level. Plans are ready to be signed and sealed by the EOR.

RRR, operational improvement, and safety projects typically have two phase reviews, which will be defined in the Scope of Services. **Table 301.2.4-2** summarizes the plans sheet status for each submittal. A phase is considered complete when all review comments have been resolved and documented.

A "Notes for Reviewers" sheet may be placed behind the Key Sheet to call attention to conditions, issues and features unique to the project design. Do not use this sheet beyond Phase III submittal.

Provide a PDF of the Summary of Pay Items Report generated from [AASHTOWare Project™](#) ~~the Department's~~ ~~Webgate~~ for each phase submittal, beginning with Phase II. Report is without quantities for Phase II submittal, and with quantities for all subsequent submittals.

Commentary on Update: On 8/24/2020 by Rob Cotleur

Date of presentation:

- Table 301.2.1 – Summary of Phase Submittals

Topic #625-000-002
FDOT Design Manual

Table 301.2.1² Summary of Phase Submittals

Provide the sheets listed as applicable

ITEM	PHASE I	PHASE II*	PHASE III	PHASE IV
Key Sheet	P		C	F
Signature Sheet		P	C	F
<u>Summary of Pay Items</u>		P	C	F
Drainage Map	P	P	C	F
Interchange Drainage Map	P	P	C	F
Typical Section	P	P	C	F
<u>Summary of Drainage Structures</u>		P	C	F
Optional Materials Tabulation		P	C	F
Project Layout	P	C	C	F
Project Control	P	C	C	F
Roadway Plan and Profile	P	P	C	F
Traffic Monitoring Site		P	C	F
Special Profile	P	P	C	F
Back-of-Sidewalk Profile	P	C	C	F
Interchange Layout	P	P	C	F
Ramp Terminal Details		P	C	F
Intersection Layout/Detail	P	P	C	F
Drainage Structures		P	C	F
Outfall/Lateral Ditch <u>System Plan and Profile</u>		P	C	F
Outfall/Lateral Ditch <u>System Cross Section</u>		P	C	F
Retention/Detention Ponds		P	C	F
Cross Section Pattern		P	C	F
Roadway Soil Survey		P	C	F
Cross Sections	P	P	C	F
Stormwater Pollution Prevention Plan		P	C	F
Temporary Traffic Control Plans	P	P	C	F
Utility Adjustments		P	C	F
Selective Clearing and Grubbing		P	C	F
Mitigation Plans		P	C	F
Miscellaneous Structures Plans		P	C	F
Signing and Pavement Marking Plans		P	C	F
Signalization Plans		P	C	F
Intelligent Transportation System (ITS) Plans		P	C	F
Lighting Plans		P	C	F
Landscape Plans	P	P	C	F
Landscape Opportunity Plans	P	P	C	F
Vegetation Disposition Plans	P	P	C	F
Utility Work by Highway Contractor Agreement Plans		P	C	F
<u>Summary of Quantities</u>		P	C	F
Developmental Standard Plans		C	C	F
Toll Facility Plans				
Site/Civil	P	P	C	F
Architectural	P	P	C	F
Structural	P	P	C	F
Electrical		P	C	F
Mechanical		P	C	F
Plumbing		P	C	F
Communications		P	C	F
Systems		P	C	F

Status Key: P - Preliminary C - Complete but subject to change F - Final

* Projects with structures plans component must submit the latest set with the 60% roadway submittal.

Commentary on Update: On 8/24/2020 by James McGinnis

Date of presentation:

- 301.2.2 – Phase II Submittal

301.2.2 Phase II Submittal

Typically, the work to be done during this phase is the following:

- (1) Address Phase I comments.
- (2) Load Pay Item numbers into the Designer Interface for AASHTOWare Project Preconstruction™. Refer to the **Basis of Estimates** for additional guidance.
- (3) Identify specifications, including any needed modified or project specific changes. Refer to the **Specifications Handbook** for additional guidance.
- (4) Develop Phase II Plans to include the following:

Unless otherwise directed by the Department, the following elements are required for a Phase II set of plans:

SUMMARY OF PAY ITEMS

- Item numbers with descriptions
- Quantities, if loaded, will not be reviewed at this phase

Topic #625-000-002
FDOT Design Manual

OUTFALL / LATERAL DITCH ~~SYSTEM~~ - PLAN VIEW

- North arrow and scale
- Roadway centerline
- Existing or survey ditch centerline
- Proposed ditch centerline with stationing
- Begin and end ditch stations
- Equations
- Ditch centerline intersection stations
- R/W lines
- Bearings of ditch and mainline centerlines
- Proposed storm drain pipes
- Ditch PI stations with deflection angle left or right
- Proposed drainage structures with structure numbers
- Existing topography, drainage structures, utilities
- Limits of wetlands

OUTFALL / LATERAL DITCH ~~SYSTEM~~ - PROFILE VIEW

- Bench mark information
- Scale
- Existing ground line
- Proposed ditch profile with grades
- Begin and end ditch stations
- High water elevations
- Proposed storm drain pipes with size
- Existing Utilities
- Overland flow or overtopping elevations
- Proposed drainage structures with structure numbers
- Typical section can be placed in either plan or profile

Topic #625-000-002
FDOT Design Manual

LATERAL DITCH CROSS SECTIONS

- Horizontal and vertical scale
- Existing ground line
- Station numbers
- Survey centerline and elevation
- R/W
- Begin and end ditch stations
- Begin and end excavation stations
- ~~Earthwork quantities~~
- Existing utilities
- ~~Total earthwork quantity in cubic yards~~
- Proposed template with ditch bottom elevation

RETENTION/DETENTION POND CROSS SECTIONS

- Horizontal and vertical scale
- Existing ground line
- Station numbers
- Begin and end pond stationing
- Pond centerline and elevations
- R/W
- Soil borings
- Water table
- Extent of unsuitable material
- **Earthwork quantities**
- Existing utilities
- Proposed template with bottom elevation

SIGNING AND PAVEMENT MARKING PLANS – TABULATION OF QUANTITIES

- **Project Specific**

SIGNING AND PAVEMENT MARKING PLANS - PLAN SHEETS

- North arrow and scale
- Basic Roadway Geometrics

SIGNALIZATION PLANS – TABULATION OF QUANTITIES

- **Project Specific**

SIGNALIZATION PLANS - PLAN SHEET

- North arrow and scale
- Basic Roadway Geometrics
- Begin/End Stations and Exceptions
- Station Equations
- Conflicting utilities, lighting or drainage
- Signal Pole Location
- Type and location of loops
- Type and location of signal heads
- Pedestrian Signal
- Location of Stop Bars

SIGNALIZATION PLANS – POLE SCHEDULESection Break (Continuous).....

- → Pole location, number, type
- → Pole dimensions
- → Pay item number **and quantity**
- → Joint use pole details, if applicable
- → Foundation design

..... Page Break ¶

ITS PLANS - TABULATION OF QUANTITIES

- Project Specific

LIGHTING PLANS - TABULATION OF QUANTITIES

- Project Specific

LANDSCAPE PLANS - TABULATION OF QUANTITIES AND PLANT SCHEDULE

- Project Specific

LANDSCAPE PLANS - TABULATION OF QUANTITIES AND SCHEDULE FOR IRRIGATION AND SITE AMENITIES

- Project Specific

Topic #625-000-002
FDOT Design Manual

- Existing and proposed overhead and underground utility locations
- Clear Zone/Lateral offset (should be plotted or safety setback distances noted frequently on each plan sheet)
- View zones for permitted outdoor advertising signs
- Canopy limits
- Existing vegetation (to remain or be removed)
- Existing off site features and conditions that affect or are affected by the project
- Fence and gate locations
- Setbacks from structural elements or drainage system
- Limits of clear sight
- Transit facilities
- Proposed Planting Plan (Plant symbols and Plant quantities)

Commentary on Update: On 8/24/2020 by James McGinnis

Date of presentation:

- 301.2.3 – Phase III Submittal

301.2.3 Phase III Submittal

Typically, the work to be done during this phase is the following:

- ~~(1) — Address Phase II review comments,~~
 - ~~(2) — Complete the Summary of Quantities (SQ) sheets and input quantities into Designer Interface for AASHTOWare Project™ Preconstruction,~~
 - ~~(3) — Update the Financial Management (FM) system (see *FDM 111.2.1*), and~~
 - ~~(4) — Provide final drainage tabulations.~~
- (1) Address Phase II comments.
 - (2) Complete all remaining Plan Sheets.
 - (3) Submit Technical Special Provisions or Modified Special Provisions for technical and legal review(s).
 - (4) Complete the Estimated Quantities Report in *FDM 902* and input quantities into Designer Interface for AASHTOWare Project Preconstruction™. Submit the Estimated Quantities Report with the Phase III Submittal.

Commentary on Update: On 8/24/2020 by James McGinnis

Date of presentation:

- 301.2.4 – Phase IV Submittal

301.2.4 Phase IV Submittal

Typically, the work to be done during this phase is the following:

- (1) Address Phase III review comments,
- (2) Update Work Zone Traffic Control and Litter Removal & Mowing pay items based on established construction duration and finalize the Summary of Estimated Quantities (SQ) sheets Report,
- (3) Place the assigned Construction Contract number on the Key Sheet(s),
- (4) Update the Work Program Administration (WPA) system (see FDM 111.2.1) to reflect the project begin and end project milepost. Verify that the Key Sheet begin and end project milepost is consistent with the information entered into the Work Program Administration (WPA) system, and

- ~~(4)(5) → Begin Preparation of Prepare Draft Specification Package with the latest e-book and workbook. ¶~~
- ~~(6) → Update quantities in Designer Interface for AASHTOWare Project™ Preconstruction and complete the EOR's construction cost estimate. Finalize the Estimated Quantities Report and update quantities in Designer Interface for AASHTOWare Project Preconstruction™. Submit the Estimated Quantities Report with the Phase IV Submittal. ¶~~
- ~~(5)(7) → Provide an Engineer of Record's construction cost estimate to the Department Project Manager (when requested). ¶~~

Commentary on Update: Change made 1/29/2020 by Darrell Lewis, then again on 8/26/2020 by James McGinnis

Date of presentation: 1/21/2020 via email per Vivian Lemus

- 301.2.5 – PS&E Phase Submittals

The first submittal consists of the Final Plans, draft Specifications Package, and PDF of the Estimated Quantities Report, and PDF of the Summary of Pay Items Report (generated from the Department's Webgate). See the **Specifications Handbook** for information on preparing Specifications Packages.

The first submittal consists of the Final Plans, draft Specifications Package and PDF of the Summary of Pay Items Report (generated from AASHTOWare Project™ Webgate). See the **Specifications Handbook (3/8/2019)** for information on preparing Specifications Packages and supplemental Specifications Packages.

After changes to the Final Plans, Specifications Package and Estimated Quantities Report, and Summary of Pay Items Report, have been completed and verified, deliver the second submittal consisting of the following:

- (1) → Signed and Sealed Plans
- (2) → Signed and Sealed Specifications Package
- (2)(3) → Signed and Sealed Estimated Quantities Report
- (3)(4) → CADD Files

Additional information on District activities during PS&E Phase is described in **FDM 131**.
Information on the delivery of Project Documentation is described in FDM 111.7.

Commentary on Update: On 8/20/2020 by James McGinnis

Date of presentation:

- Table 301.3.1 – Summary of Design-Build Phase Submittals

Topic #625-000-002
 FDOT Design Manual

Table 301.3.1 Summary of Design-Build Phase Submittals

Provide the sheets listed as applicable

ITEM	TECHNICAL PROPOSAL	90% PLANS	FINAL PLANS
Key Sheet		P	F
Signature Sheet		P	F
Drainage Map	P	C	F
Interchange Drainage Map	P	C	F
Typical Section	P	C	F
Summary of Drainage Structures		C	E
Project Layout		C	F
Project Control	P	C	F
Roadway Plan and Profile	P	C	F
Traffic Monitoring Site	P	C	F
Special Profile		C	F
Back-of-Sidewalk Profile		C	
Interchange Layout	P	C	F
Intersection Layout/Detail	P	C	F
Drainage Structures		C	F
Outfall/Lateral Ditch Plan Profile		C	F
Outfall/Lateral Ditch Cross Section		C	F
Retention/Detention Pond Details		C	F

Commentary on Update: On 8/20/2020 by James McGinnis

Date of presentation:

- 301.3.3 - 90% Plans Component Submittal Requirements

TYPICAL SECTIONS

- Mainline and crossroad typical sections
- R/W lines
- Special details (e.g., bifurcated sections, high fills)
- Traffic data
- Pavement Design

SUMMARY OF DRAINAGE STRUCTURES

- ~~Complete~~

PROJECT LAYOUT

- Plan-profile sheet sequence (mainline and crossroads)

PROJECT CONTROL

- Complete

Topic #625-000-002
FDOT Design Manual

OUTFALL / LATERAL DITCH ~~SYSTEM~~ - PLAN VIEW

- North arrow and scale
- Roadway centerline
- Existing and survey ditch centerline
- Proposed ditch centerline with stationing
- Begin and end ditch stations
- Equations
- Ditch centerline intersection stations
- R/W lines
- Bearings of ditch and mainline centerlines
- Proposed storm drain pipes
- Ditch PI stations with deflection angle left or right
- Proposed drainage structures with structure numbers
- Existing topography, drainage structures, utilities
- Limits of wetlands

OUTFALL / LATERAL DITCH ~~SYSTEM~~ - PROFILE VIEW

- Bench mark information
- Scale
- Existing ground line
- Proposed ditch profile with grades
- Begin and end ditch stations
- High water elevations
- Proposed storm drain pipes with size
- Existing Utilities
- Overland flow or overtopping elevations
- Proposed drainage structures with structure numbers
- Typical section can be placed in either plan or profile

RETENTION/DETENTION POND CROSS SECTIONS

- Horizontal and vertical scale
- Existing ground line
- Station numbers
- Begin and end pond stationing
- Pond centerline and elevations
- R/W
- Soil borings
- Water table
- Extent of unsuitable material
- ~~Earthwork quantities~~
- Existing utilities
- Proposed template with bottom elevation

Commentary on Update: On 8/20/2020 by James McGinnis

Date of presentation:

- 301.3.4 Final Plans Submittal

Topic #625-000-001
FDOT Design Manual

301.3.4 Final Plans Submittal

Ordinarily, the remaining work to be done will be to:

- (1) Comply with comments received as a result of the 90% review,
- (2) Update all plan sheets and the Financial Management (FM) system, and
- ~~(3) Provide final drainage tabulations for review, and~~
- ~~(4)~~(3) Provide Utility Work by Highway Contractor (UWHC) Agreement Plans, consisting of a key sheet, and mainline plan-profile showing proposed utility horizontal and vertical locations.

Commentary on Update: On 8/20/2020 by James McGinnis

Date of presentation:

301.4 Alternative Intersection and Interchange Review

~~Alternative intersections and interchanges provide a fresh approach to addressing congestion and safety concerns on the State Highway System. They are typically more complex than conventional designs and there is little guidance available to designers. For these reasons, all proposed Alternative Intersection and Interchange designs require a detailed review early and throughout the design process.~~

~~Configurations subject to this detailed review are listed as follows:~~

- ~~▲ Roundabout~~
- ~~▲ Median U-Turn (MUT)~~

301-Sequence of Plans Preparation

Topic #625-000-001
FDOT Design Manual

- ~~▲ Restricted Crossing U-Turn (RCUT)~~
- ~~▲ Jug Handle~~
- ~~▲ Displaced Left Turn~~
- ~~▲ Continuous Green-T~~
- ~~▲ Quadrant Roadway~~
- ~~▲ Diverging Diamond Interchange (DDI)~~

~~Include Alternative Intersection and Interchange Review Packages in the Phase I Submittal. Designate a representative of the State Roadway Design Office as a Lead Reviewer for all phases in ERC.~~

~~**See *FDM 116* for more information on Alternative Intersection and Interchange reviews.**~~

FDM 302 (Key Sheet)

Commentary on Update: On 8/13/2020 by Bobby Bull. Updated per the FDM Review Session

- 302.4 – Project Location Map and North Arrow

~~The project location map is typically located on the lead component Key Sheet.~~

Commentary on Update: On 2/19/2020 by Darrell Lewis.

Date of presentation:

- 302.6 – Index of Roadway Plans

302.6 → Index of Roadway Plans

Place an index of roadway sheets on the left side of the Key Sheet. Each component Key Sheet will have an index of sheets contained in that component. Assemble roadway plans in the following order:Section Break (Continuous).....

- (1) → Key Sheet
- (2) → Signature Sheet
- ~~(3) → Summary of Pay Items~~
- ~~(4)(3) → Drainage Map~~
- ~~(5)(4) → Interchange Drainage Map~~
- ~~(6)(5) → Typical Section~~
- ~~(7) → Summary of Drainage Structures~~
- ~~(8) → Optional Materials Tabulation~~
- ~~(9)(6) → Project Layout~~
- ~~(10)(7) → Project Control~~
- ~~(11)(8) → General Notes~~
- ~~(12)(9) → Roadway Plan and Profiles~~
- ~~(13)(10) → Traffic Monitoring Site~~
- ~~(14)(11) → Special Profiles~~
- ~~(15)(12) → Back-of-Sidewalk Profiles~~
- ~~(16)(13) → Interchange Layout~~
- ~~(17)(14) → Ramp Terminal Details~~
- ~~(18)(15) → Intersection Layout/Detail~~
- ~~(19)(16) → Drainage Structures~~
- ~~(20)(17) → Outfall/Lateral Ditch Plan and Profiles~~
- ~~(21)(18) → Outfall/Lateral Ditch Cross Sections~~

Topic #625-000-002
FDOT Design Manual

→

¶
¶

- ~~(22)~~(19) → Special Details¶
- ~~(23)~~(20) → Cross-Section Pattern¶
- ~~(24)~~(21) → Roadway Soil Survey¶
- ~~(25)~~(22) → Cross Sections¶
- ~~(26)~~(23) → Stormwater Pollution Prevention Plans (SWPPP)¶
- ~~(27)~~(24) → Temporary Traffic Control Plans¶
- ~~(28)~~(25) → Utility Adjustments¶
- ~~(29)~~(26) → Selective Clearing and Grubbing¶
- ~~(30)~~(27) → Tree Disposition Plan¶
- ~~(31)~~ → Summary of Quantities⁽¹⁾¶
- ~~(32)~~(28) → Developmental Standard Plans¶
- ~~(33)~~(29) → Signing and Pavement Marking Plans⁽²⁾¶
- ~~(34)~~(30) → Signalization Plans⁽²⁾¶
- ~~(35)~~(31) → ITS Plans⁽²⁾¶
- ~~(36)~~(32) → Lighting Plans⁽²⁾¶
- ~~(37)~~(33) → Landscape Plans⁽²⁾¶
- ~~(38)~~(34) → Mitigation Plans¶
- ~~(39)~~(35) → Miscellaneous Structures Plans¶
- ~~(40)~~(36) → Toll Facilities⁽²⁾¶ Section Break (Continuous)

(1) Place at the end of the numbered roadway plan sheets. ¶

(2) When the work for these components is minor, sheets may be included (and numbered sequentially) in the lead component; do not show these as component plans. ¶

Commentary on Update: On 8/18/2020 by James McGinnis.

Date of presentation:

- 302.6.1 – Early Works

302.6.1 Early Works

The roadway plans may require insertion of sheets that were prepared early, or prior to the design process. These sheets may be identified and numbered with the following prefixes:

- (1) GR-# Soil Survey and Report of Core Borings normally associated with the roadway plans set (including miscellaneous structures but excluding bridges and walls)
- (2) TR-# Tree Survey
- (3) UTV-#Verified Utility Locate

Show these early works sheets in the index of roadway plan sheets behind the Summary of Quantities sheets. These sheets appear as the last item in the index of roadway plan sheets. Include an asterisk next to the early works title and a note below the index per **Exhibit 302-1.**

Commentary on Update: Changed reference from FDM 131 to FDM 132.

Date of presentation: Changed on 7/21/2020 via email per Anna Harlson.

- 302.10 – Revisions

302.10 Revisions

The process and requirements for completing plan revisions are provided in **FDM 132[#]**.

Commentary on Update: Changed as requested from Final Plans. OGC review complete on 9/16/2020

Date of presentation: Changed per email from Jodi Jarrell and Paul Hiers

- 302.11 – Strung Projects

302.11 Strung Projects

Contract plans that are independently prepared but are let in the same construction contract are referred to as strung projects. When a federally-funded project is strung with a non-federal eligible (NFE) project, the federally-funded project is ~~to be~~typically the lead project. When a federally funded project is strung with a state funded project, the entire contract becomes federalized; i.e., both the state funded project and the federally funded project must comply with all applicable federal laws, rules, and regulations related to the federalized contract. For each set of contract plans that are to be strung, place the strung project note on the lead component Key Sheet as shown in **Exhibit 302-1**. Show the strung project note only on lead component Key Sheets.

List revisions to any strung project on the lead component Key Sheet of the lead project under the “REVISIONS” header, under the respective Financial Project ID.

FDM 304 (Summary of Pay Items)

Commentary on Update: Changed 9/8/2020

Date of presentation:

- 304.1 – General

304.1 → General¶

The Summary of Pay Item sheets are no longer produced for contract plans. See **FDM 902** for guidance on the Estimated Quantities Report and Summary of Pay Items Report. The summary of pay items sheet Estimated Quantities Report is generated from information provided by the Engineer of Record (EOR) and input into Designer Interface. The Summary of Pay Items Report is generated in AASHTOWare Project™ the Department's Webgate Reporting (formerly Trns*port Reports Menu).¶

For early phase reviews (up to Phase III, or until the proposal has been created), the Summary of Pay Items Report will include the summary of pay items for the individual project number selected. If multiple projects are anticipated to be let together, download the XML file for each project's Summary of Pay Items sheet(s) in the plans. Once the proposal has been created, the report will generate all the pay items for multiple projects combined using the lead project financial project number, and the extra downloads will not be required.¶

Transfer the downloaded XML file to a graphics design file and place on a standard plan sheet available in the FDOT CADD Software. Designer Interface must be kept current with the quantities in the plans. It is critical that any revisions to the quantities be updated in the Designer Interface. Once updated, the Summary of Pay Items Report must be rerun to download the new XML to update the graphics design file. The Summary of Pay Items Report file is used to prepare the bid documents and must match the pay items and quantities shown in the plans in the Estimated Quantities Report.¶

304.2 → Summary of Pay Items Sheet¶

The summary of pay items sheet(s) lists all pay items and quantities for all components for the project, or projects, in a contract.¶

Topic #625-000-002
 FDOT Design Manual

→

→

¶

¶

~~Place summary of pay items sheets directly behind the lead signature sheet. Place the summary of pay items on the sheet(s) in the order generated in the AASHTOWare Project™ WebGate Reporting menu (formerly Trns*port Reports Menu), Summary of Pay Items Report XML file which the FDOT CADD Software uses to automate the creation of the sheet(s), or in the same order as the list of Contract Plans components shown on the lead key sheet. Alpha suffixes may be used for sheet numbering to allow for the insertion of additional sheets without renumbering the Index of Sheets. ¶~~

~~Strung projects, those that are independently prepared but are to be let in the same construction contract, must combine all pay items and quantities into a single Proposal Summary of Pay Items Report to be placed in the lead project. If the Proposal has not been created for the project yet, the Summary of Pay Items must contain the Summary Reports for all of the individual project numbers included in the strung project. ¶~~

~~Only the lead key sheet for the entire contract should contain reference to summary of pay items. ¶~~

~~A summary of pay items sheet without quantities is required at the Phase II submittal, and a complete summary of pay items sheet with quantities is required at the Phase III and Phase IV submittals. ¶~~

~~For a list of standard pay item notes see [FDM 307.2.2](#). ¶~~

FDM 305 (Drainage Map and Bridge Hydraulic Recommendation Sheet)

Commentary on Update: Changed "Section 5.6.9" to "Chapter 5" as the original reference no longer exists.

Date of presentation: Changed on 8/11/2020 via email per Kathy Earp.

- 305.2.4 – Existing Structures Data, Hydraulic Design Data, and Hydraulic Recommendations

305.2.4 Existing Structures Data, Hydraulic Design Data, and Hydraulic Recommendations

The [Drainage Design Guide](#), [Section Chapter 5.6.9](#) provides additional guidance for this section.

FDM 307 (Summary of Quantities)

Commentary on Update: On 7/15/2020 by James McGinnis and on 9/3/2020 by Gevin McDaniel.

Date of presentation:

- 307 – Summary of Quantities: This chapter has been significantly reduced to only the verbiage seen below. Section 307.5 is now the new FDM 117

307·Summary·of·Quantities¶

~~The Summary of Quantities of Pay Items sheets are no longer produced for contract plans for projects that begin the design phase starting in January 2021. See **FDM 902** for guidance on the Estimated Quantities Report and Summary of Pay Item Reports.¶~~

FDM 308 (Summary of Drainage Structures and Optional Materials Tabulation)

Commentary on Update: Proposed language vetted with Jennifer Green on 9/8/2020

Date of presentation:

- 308 – Summary of Drainage Structures and Optional Materials Tabulation

308.1 General

The Summary of Drainage Structures sheet ~~shows the location, size, length, number and type of drainage structures used in a project~~ will no longer be produced. See **FDM 902** for guidance on the Estimated Quantities Report. ~~The sheet format is available in the FDOT CADD Software. Specific levels and fonts are in the CADD Manual.~~

See **Exhibit 308-1** for an illustration of the Summary of Drainage Structures sheet.

The Optional Materials Tabulation sheet is included when providing acceptable options for pipe material and sizes that will satisfy the Design Service Life. The sheet format is available in the FDOT CADD Software.

See **Exhibits 308-2.1** and **308-3.2** for illustrations of Optional Materials Tabulation sheets.

308.2 Summary of Drainage Structures

~~Prepare and include a summary of drainage structures in the plans. List the structures in numerical order of structure number. Identify the location of each structure by station along the centerline of construction.~~

Tabulate storm and cross drains in the summary of drainage structures by structure number, providing the station, size, length and incidental quantities appropriate for the material detailed in the plans. When the number of columns exceeds one page, the additional sheet is to be numbered using a suffix (e.g., 3 and 3A, 4 and 4a). Information for the drainage elements in the columns is obtained from drainage structure sheets and plan profile sheets. The order in which the elements are listed should be as follows:¶:.....

- | | |
|-------------------------------|------------------------------|
| (1) → Pipe Sizes for¶ | (5) → Ditch Bottom Inlets¶ |
| (a) → Storm and Cross Drains¶ | (6) → Gutter Inlets¶ |
| (b) → Gutter Drain¶ | (7) → Flared End Sections¶ |
| (2) → Curb Inlets¶ | (8) → Mitered End Sections¶ |
| (3) → Manholes¶ | (9) → Performance Turf, Sod¶ |
| (4) → Junction Boxes¶ | (10) → Class of Concrete¶ |

¶
308-Summary of Drainage Structures and Optional Materials Tabulation → ¶

(11) → Reinforcing Steel

(12) → RiprapSection Break (Continuous).....

Use the "Description" column to specify the type of structure, the outgoing pipe and the end treatment of that pipe, if applicable.

The remarks column contains special notes pertaining to the structure. The "Final Quantity" line is for construction to use and must be left blank.

It is recommended that structure numbers be established using the convention shown in the exhibits and described as follows:

(1) → For simple cross-drains, one structure number is appropriate for the inlet, pipe and outlet treatments.

Example #1 → (cross drain w/o median inlet)

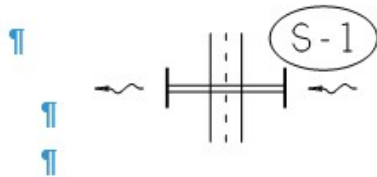

(2) → For complex cross-drains, it is suggested that the first and all intermediate structure numbers identify the hydraulically upper end treatment and pipe. The last structure number should identify the hydraulically upper end treatment, pipe and hydraulically lower end treatment.

Example #2 → (Double pipe cross drain and median inlet)

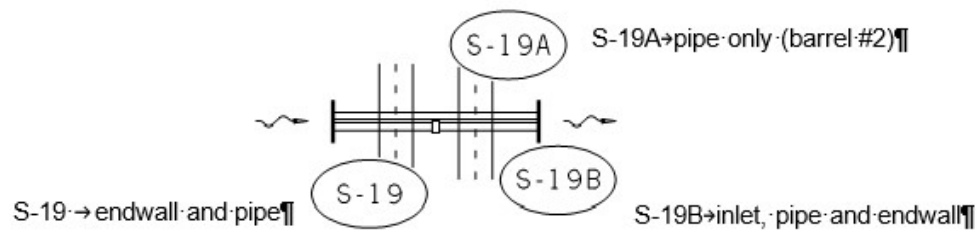

Topic #625-000-002
 FDOT Design Manual

308.32 → Optional Materials Tabulation

Optional culvert materials must be considered for all culverts; however, culvert extensions and end-section replacements are to match the existing culvert material. See Chapter 8 of the [Drainage Design Guide](#) for more information.

Conduct an Optional Pipe Materials Analysis and prepare an Optional Materials Tabulation sheet to be placed in the plans.

The Optional Material Tabulation sheet is to include:

- (1) → Structure number, or description
- (2) → Design service life (DSL)
- (3) → Size
- (4) → Material and thickness or class, corrugation requirements, protective coating

Modification for Non-Conventional Projects:

Delete **FDM 308.3-2** and see **Chapter 6** of the [Drainage Manual](#) for Optional Material requirements. Designate installed material on the Optional Materials Sheet, [Summary of Drainage Structures](#), or on the as-built plan view.

FDM 311 (General Notes)

Commentary on Update: On 7/8/2020 by Melissa Hollis.

Date of presentation:

- 311.1 – General

311.1 General

General notes provide information and direction to the contractor by clarifying design details or construction practices. General notes are project-specific and must not restate, broaden or curtail requirements in the [Standard Specifications](#) or [Standard Plans](#).

General notes are not a substitute for specifications; refer to the Specifications Handbook for guidance. Contact the District Specifications Office for assistance with Modified Special Provisions, Technical Special Provisions, or other specification needs.

Place general notes on a standard plan sheet available in the FDOT CADD Software. Place the General Notes sheet before the first roadway plan-profile sheet in the plans set. See **Exhibit 311-1** for an example of a General Notes sheet.

Commentary on Update: On 7/8/2020 by Melissa Hollis.

Date of presentation:

- 311.2.1 – Required General Notes

(6) All roadway work within the railroad right-of-way must be completed in consecutive calendar days (to be determined jointly by the District Construction and Rail Offices). The work to be completed includes all items necessary to relieve the flagman from providing protective services.

FDM 315 (Drainage Structures)

Commentary on Update: Removed “major underground” referencing definition in FDM 221 due to not existing.

Date of presentation: 7/16/2020 via e-mail per William Summers & Shawn Lewis and reedited on 8/3/2020 after Teams meeting for clarification.

- 315.3 – Utility Conflicts

315.3 Utility Conflicts

Identify and resolve drainage structure conflicts with existing or proposed utilities as early in the design process as possible. Plot ~~major underground~~ utilities, as defined in **FDM 221**, in conjunction with the structures to identify potential conflicts.

Note and plot (to scale) the utilities that have been verified (Quality Level "A" locate) in the appropriate locations on the Drainage Structure Sheets, Cross Section Sheets and bridge foundation plans. These utilities should be labeled with the following symbol:

V_{vh1} = Verified Vertical Elevation and Horizontal Location and pipe ID number

FDM 319 (Cross Sections)

Commentary on Update: On 8/19/2020 by James McGinnis and again on 9/3/2020 by Gevin McDaniel.

Date of presentation:

- 319.2 – Required Information

~~Indicate earthwork quantities in the appropriate columns on the right side of the cross section sheet. Show earthwork summaries in the Summary of Earthwork on in the Summary of Quantities Sheet. Estimated Quantities Report. For projects beginning the design phase in January 2021, show earthwork quantities in the Estimated Quantities Report. See **FDM 902** for guidance.~~¶

FDM 323 (Selective Clearing and Grubbing Plans)

Commentary on Update: On 8/12/2020 by Rob Cotleur

Date of presentation:

- 323.1 – General

323.1 General

Selective Clearing and Grubbing Plan sheets are developed when existing vegetation, trees, and palms are to be protected, relocated, **pruned**, or removed as an alternative to Standard Clearing and Grubbing. **FDM 229** contains design criteria to determine the type and the limits of selective clearing and grubbing.

Commentary on Update: On 8/5/2020 by Rob Cotleur

Date of presentation:

- 323.2.1 – Sheet Set Up

When tree canopies overlap, the entire outline of the tree canopies can be shown as one mass. ~~Show tree protection barrier on the plans. and summarize the quantities, (per linear foot), in a summary box. Branch and root pruning locations.~~ When existing trees to remain are to be root pruned, the trees are assigned a label which ~~is should also be summarized, (per tree), in a summary box and shown as adjacent to the tree trunk. Trees that are to be branch pruned on the Tree Disposition Charts.~~ These items may also be labeled ~~in the plans. on the plans when needed for clarity or clarity or called out in the Selective Clearing & Grubbing Work Table, but must be quantified per tree.~~ Each tree does not need to be labeled when a group of trees are to be branch pruned. ~~Label areas but the quantity of root or branch pruning on the plans or in the Work Table. trees to be pruned must be provided.~~ The disposition of trees to be relocated is shown on Tree Disposition sheets. For an example of a Tree Disposition Sheet and a Tree Disposition Chart, see **Exhibit 323-3** and **323-4**.

Where clarification is needed, trees to be removed may be noted on the plan.

Generally, the line between where standard clearing and grubbing occurs and where trees to be protected, relocated, or selectively removed demarcates a selective clearing and grubbing area. Selective clearing and grubbing areas are not always demarcated by a means of vegetation treatment or protection (tree protection **fencing barrier**). Areas of tree protection, plant preservation, or selective clearing and grubbing may be delineated with tree protection barriers. When a **plant preservation tree protection** area is adjacent to a R/W fence to remain, **a sediment barrier**, or similar permanent barrier, **the** tree protection barrier **that is** parallel to the permanent barrier may be omitted.

323.3 Selective Clearing and Grubbing Detail Sheet

Commentary on Update: On 8/5/2020 by Rob Cotleur

Date of presentation:

- 323.3.2 – Species Legend and Work Table Notes

Category 1 plants (as listed by the [Florida Exotic Pest Plant Council](#)) are undesirable, and in most cases should be listed to be removed. The designer may call out Category 1 plants that are to remain in the [Work Table Notes](#) or in the Selective Clearing and Grubbing Work Table, **in cases where it may not be practical or feasible to remove them.** Undesirable native species to be targeted for removal can also be listed.

Commentary on Update: On 8/5/2020 by Rob Cotleur

Date of presentation:

- 323.4 – Tree Disposition Sheets

Tree Disposition Sheets may be omitted if **required information and** tree relocations can be clearly and legibly shown on Selective Clearing and Grubbing **or Landscape** Plan sheets. If a tree or vegetation survey is available, utilize either Selective Clearing and Grubbing, **Landscape** or Tree Disposition sheets, showing all information on one sheet type on the Tree Disposition Chart. If there is no tree or vegetation survey, utilize only Selective Clearing and Grubbing **or Landscape** Sheets to show all information.

Note the following **on in the** plans:

Commentary on Update: On 8/12/2020 by Rob Cotleur

Date of presentation:

- 323.5 – Tree Disposition Chart

- Condition of the tree including health, structure, and damage. Use the **following (simplified) version of the** International Society of Arboriculture (ISA) tree rating system. (Excellent, **Very Good**, **Good**, **Good/Fair**, Fair, Poor, **Critical**, Dead)
- Label the disposition of each tree as “To Remain,” “To Be Removed,” or “To Be Relocated.” The location for relocation may be added. For CADD symbols refer to **Exhibit 323-3**.
- If a tree or palm is removed following the Vegetation Survey, note ‘Tree/Palm does not exist’

Note: Collecting and providing information on the height and spread of trees may not be cost effective, relevant, or feasible, depending on the scale of the project. **In addition, large scale projects may not require that all trees on the survey are included in the Tree Disposition Charts. If all trees shown on the survey are not included in the Tree Disposition Charts, then a note must be added to the plans stating this for clarification.**

A note must be added to the Tree Disposition Charts when all trees are not shown from the Tree Survey.

Commentary on Update: On 8/12/2020 by Rob Cotleur

Date of presentation:

- 323.6 – Root and Branch Pruning

323.6 Root and Branch Pruning

Root and/or Branch pruning can be shown ~~on~~ in a summary box plant schedule in either the Selective Clearing and Grubbing ~~Sheets, Landscape, or the~~ Tree Disposition ~~Sheets~~ Plans. Do not duplicate information on ~~both plans~~ separate plan sets. Use the sequence of construction to determine where to show root or branch pruning. If root or branch pruning will need to be accomplished early in the construction process, show on the Selective Clearing and Grubbing Plans. If pruning needs to be accomplished late in the construction process, show pruning on the Tree Disposition or Landscape Plans. Always specify the pruning ~~intent~~ objectives, whether for structural purposes, aesthetics, safety, clearance, etc... Ensure there is enough information provided so this work can be accurately bid by the Contractor and inspected for compliance by the Engineer. Consider referencing the applicable sections related to pruning objectives and methods in accordance with ANSI A300 (part 1).

FDM 324 (Miscellaneous Structures)

Commentary on Update: On 9/8/2020 by Bobby Bull.

Date of presentation:

- 324.3 – Retaining Walls

324.3 Retaining Walls

Non-proprietary retaining walls require complete design and construction details, ~~pay items, and quantities to be included~~ in the contract plans.

~~Modification for Non-Conventional Projects:~~

~~Delete the sentence above and replace with:~~

~~Non-proprietary retaining walls require complete design and construction details in the contract plans.~~

Commentary on Update: On 8/19/2020 by James McGinnis and on 9/4/2020 by Gevin McDaniel and on 9/8/2020.

Date of presentation:

- 324.4 – Concrete Box Culverts

324.4 Concrete Box Culverts

~~Certain These sheets are to be placed~~ Place these sheets in a ~~s~~Structures ~~C~~omponent, even when there are no bridge plans. ~~Some of these sheets were previously shown in the Roadway Component Plan, but all of them are now to be shown in the Structures Component Plan regardless if the box culvert is categorized as a bridge or not.~~

Concrete box culverts require complete design and construction details, ~~pay items, and quantities~~ to be included in the contract plans. Include the following minimum design details:

~~Modification for Non-Conventional Projects:~~

~~Delete the above paragraph and replace with the following:~~

~~Concrete box culverts require complete design and construction details to be included in the contract plans. Include the following minimum design details:~~

(1) Plan view ~~(usually shown on the Plan-Profile sheet in the Roadway Plans Component) — see FDM 312, Exhibit 312-1)~~ showing: Grid north arrow; scale bar; existing highway boundaries including existing R/W monuments; new R/W line(s)

Commentary on Update: On 8/18/2020 by James McGinnis and on 9/3/2020 by Gevin McDaniel

Date of presentation:

- 324.4 – Concrete Box Culverts

~~(2)~~(1) Elevation view ~~(usually shown on the Plan-Profile sheet in the Roadway Plans Component) — see FDM 312, Exhibit 312-1)~~ showing: Elevation vertical scale; profile grade line and vertical data; existing stream bottom and ground line (along PGL); utilities.

~~(3)~~(2) A longitudinal section along the culvert centerline ~~(usually shown on the Drainage Structures sheet in the Roadway Component — see FDM 315, Exhibit 315-2)~~ showing: Culvert or bridge identification number; invert elevations; existing stream bottom or original ground; culvert stationing at centerline; typical highway section (including rail treatment); design earth cover height (measured from the top of the top slab to the top of pavement); limits of scour protection (including any keyways or geotextile fabric lining); channel work; culvert end treatments; utility (either attached to the fascia, or in the embankment, traffic railing or sidewalk); wing walls; headwalls; cutoff walls; reference to the appropriate **Standard Plans**.

~~(4)~~(3) Data Sheets ~~(see FDM 307.3)~~: Box Culvert Data Table and Reinforcing Bar List are to be placed in a Structures Component.

~~(5)~~(4) Miscellaneous details showing ~~(usually shown on Box Culvert Detail sheets which are to be placed in a Structures Component)~~: Construction phasing information (affects lengths of precast segments and potential need for skewed segments) including appropriate excavation support and protection systems (e.g., critical temporary walls); traffic railing details including connection details; slope and/or stream bank protection; channel section detail; culvert-end safety grate, guardrail or fencing details when applicable; removal of existing culvert(s); cofferdams or water diversion.

~~(6)~~(5) Notes ~~(usually on the Box Culvert Data Sheets)~~ indicating: Live loading requirements (HL-93 or HS-25); hydraulic data (show 100-year design flow or the design flow used and the minimum hydraulic area perpendicular to flow below the Design High Water); environmental classification for durability; minimum concrete class and reinforcing steel grade; assumed soil weight, angle of internal friction and nominal bearing capacity; differential soil settlement height and effective length (when significant); precast culvert limitations; any special joint waterproofing requirements; erosion and sediment control and stormwater pollution prevention plan requirements; restrictions for work in streams; estimated quantities.

~~(7)~~(6) A Plan and Elevation sheet and a Load Rating Summary sheet are required for box culverts classified as bridge culverts (per **FDM 265.1**). These sheets are to be placed in a Structures Component.

In accordance with the **Basis of Estimates**, load pay items and quantities for box culverts in the roadway category and for bridge culverts in the structures category.

Commentary on Update: On 8/13/2020 by Bobby Bull and on 9/8/2020 by Gevin McDaniel. On 9/4/2020 by Bobby Bull

Date of presentation:

- 324.5 – Three-Sided Concrete Culverts

- (5) Complete details for cast-in-place wingwalls, including geometry and reinforcement details.
- ~~(6) Estimated quantities for concrete and reinforcing steel for cast-in-place elements, but do not include separate pay items.~~
- ~~(7) Identify payment limits as the length of the total structure along a longitudinal centerline of the structure.~~
- ~~(8)~~(6) Include the applicable details in **FDM 324.4**.
- ~~(9)~~(7) Place the following notes adjacent to the plan or elevation views, as applicable:
 - (a) The assumed foundation vertical reaction is ____ kips/ft. The assumed foundation horizontal reaction is ____ kips/ft. The Contractor must submit

a revised foundation design to the Engineer if the actual loads of the supplied structure exceed these assumed values. Any revised foundation design must be included in the ~~working shop~~ drawings and submitted for approval at the same time as the design calculations for the three-sided structure.

If the Contractor proposes to substitute square ends, details of the traffic railing attachment must be provided in the ~~working shop~~ drawings and approved by the Engineer.

Modification for Non-Conventional Projects:

Delete Item (6) above.

FDM 325 (Signing and Pavement Marking Plans)

Commentary on Update: On 9/3/2020 by Bobby Bull.

Date of presentation:

325.1 – General

325.1 → General¶

Signing and Pavement Marking (S&PM) Plans are usually a component set of plans. Component plans are assembled as a separate plans set complete with a Key Sheet, ~~Tabulation of Quantities,~~ and all other required signing and pavement marking sheets. Number the component plans with the sheet numbers prefixed by the letter "S"; e.g., S-1, S-2, S-3. ¶

~~Modification for Non-Conventional Projects: □~~

~~Delete the second sentence from the above paragraph and replace with the following: ¶~~

~~Component plans are assembled as a separate plans set complete with a Key Sheet and all other required signing and pavement marking sheets. □~~

Projects with minimal signing and pavement marking improvements may show these features on signing and pavement marking sheets in the roadway plan set (lead component) or detailed on the Roadway Plan sheets. Do not use the prefix letter "S" when including signing and pavement marking sheets in the roadway plan set. ~~See~~ [FDM-307.1](#) for placing ~~Tabulation of Quantities~~ sheet in the Roadway plan set. ¶

~~Modification for Non-Conventional Projects: □~~

~~Delete the last sentence from the above paragraph. □~~

Comply with the requirements in **FDM-230** in the selection of the permanent pavement marking materials to be used. ¶

Commentary on Update: On 9/3/2020 by Bobby Bull.

Date of presentation:

- 325.2 – Key Sheet

.325.2 → Key-Sheet¶

The Key-Sheet is the first sheet in the component plans set. The location map and Contract Plans Components list are not required on this sheet. Show the Index of S&PM Plans on the left side of the sheet. Assemble S&PM plans in the following order.¶

- (1) → Key-Sheet¶
- (2) → Signature Sheet (if required)¶
- ~~(3) → Summary of Pay Items (when lead component)¶~~
- ~~(4) → Tabulation of Quantities¶~~
- ~~(5)~~~~(3)~~ → General Notes (if required)¶
- ~~(6)~~~~(4)~~ → S&PM Plan¶
- ~~(7)~~~~(5)~~ → Guide Sign Worksheet (if required)¶
- ~~(8)~~~~(6)~~ → Overhead Sign Cross Section (if required)¶
- ~~(9)~~~~(7)~~ → Overhead Sign Support Design (if required)¶
- ~~(10)~~~~(8)~~ → Foundation Details (if required)¶
- ~~(11)~~~~(9)~~ → Boring Data (if required)¶

Modification for Non-Conventional Projects:¶

Delete item number (3) above.¶

Commentary on Update: On 8/19/2020 by James McGinnis

Date of presentation:

- 325.4 – Tabulation of Quantities and Pay Item Notes

Topic #625-000-002 →

FDOT Design Manual →

325.4 → Tabulation of Quantities and Pay Item Notes¶

~~The Tabulation of Quantities Sheets and Pay Item Notes are no longer produced for projects that beginning the design phase in January 2021. See **FDM 902** for guidance. ¶~~

~~Prepare the Tabulation of Quantities sheet using the standard plan format showing quantities, standard sign numbers, pay item numbers (except for pavement markings pay items) and size of sign for all pay items. The sign size and standard sign number is not required if shown in the plans sheets. List pay items in numerical order and tabulate quantities per sheet or by station. When the number of pay item columns exceed one page, the additional sheet is to be labeled using an alphabetic suffix; e.g., S 3 and S 3A, S 4 and S 4A. Provisions must be made to show the original and final quantities. ¶~~

~~On contracts with multiple Financial Project ID numbers, or Federal Aid and non Federal Aid quantities, provisions must be made to tabulate and summarize their respective quantities. ¶~~

~~Show pay item notes and standard notes that refer to item numbers on this sheet. ¶~~

~~For pay item 710 90 (Painted Pavement Markings (Final Surface) Lump Sum), the Tabulation of Quantities sheet should show the detailed description of the pay item and the quantities for each pay item, except in lieu of the pay item number substitute an "*" in the Bid Item Number Column (see **FDM 325.4.1**). ¶~~

~~When there is not a roadway component, see **FDM 307.1** for placing place the Summary of Quantities sheets in behind the Signing and Pavement Marking plan set. ¶~~

~~See **Exhibit 325-1** for an example Tabulation of Quantities sheet. ¶~~

~~325.4.1 → Standard Notes¶~~

~~Add the following note at the bottom of the Tabulation of Quantities sheet:¶~~

~~* → These quantities are paid for under Painted Pavement Markings (Final Surface), Lump Sum Item No. 710 90. The quantities shown are for one application; see **Specification 710** for the number of applications required. ¶~~

Modification for Non Conventional Projects:¶

Delete **FDM 325.4**¶

Commentary on Update: Added text to create consistency between 325.6.1, 326.7.1, 327.6.1 & 328.6.1 on 7/16/2020 and on 6/2/2020 by Gevin McDaniel.

Date of presentation: 7/16/2020 via e-mail per William Summers & Shawn Lewis

- 325.6.1 – Required Information

325.6.1 Required Information

The basic information pertaining to roadway geometrics and project limits required on the signing and pavement marking plan sheets is the same as that required on the plan portion of the plan-profile sheets. Topography and construction details need not be shown. Show underground and overhead utilities, lighting structures, signal structures and ITS structures that may cause construction conflicts with sign components. Check utilities, drainage, landscape features, sidewalks, and driveways for conflicts. Identify those that may cause conflicts in the plans.

- (5) Indicate size, standard designation, or assigned number if nonstandard for each sign Indicate the pay item number, sign size, standard designation, or assigned number (if nonstandard) for each sign.

- ~~(8)~~(9) Indicate location of tubular markers by specifying color. If applicable, specify the spacing and limits of application by stations.

FDM 326 (Lighting Plans)

Commentary on Update:

Date of presentation:

- 326.1 – General

326·Lighting·Plans¶

▪

▪ **326.1 → General¶**

Lighting·plans·include·construction·details,·electrical·circuits,·pole·data,·conduits,·service·points,·luminaires,·foundations,·boring·details·and·other·data·relevant·to·lighting·projects.¶

Lighting·plans·are·usually·a·component·set·of·plans.·Component·plans·are·assembled·as·a·separate·plans·set·complete·with·a·Key·Sheet,·Tabulation·of·Quantities·and·all·other·required·lighting·sheets.·Number·the·component·plans·with·the·sheet·numbers·prefixed·by·the·letter·“L”;·e.g.,·L-1,·L-2,·L-3.¶

~~Modification·for·Non·Conventional·Projects:¶~~

~~Delete·the·second·sentence·from·the·above·paragraph·and·replace·with·the·following:¶~~

~~Component·plans·are·assembled·as·a·separate·plans·set·complete·with·a·Key·Sheet·and·all·other·required·lighting·sheets.¶~~

Projects·with·minimal·lighting·improvements·may·show·these·features·on·lighting·sheets·included·in·the·roadway·plan·set·(lead·component)·or·detailed·on·the·Roadway·Plan·sheets.·Do·not·use·the·prefix·letter·“L”·when·including·lighting·sheets·in·the·roadway·plan·set.·~~See·FDM·307.1·for·placing·Tabulation·of·Quantities·sheet·in·the·Roadway·plan·set.~~¶

~~Modification·for·Non·Conventional·Projects:¶~~

~~Delete·the·last·sentence·from·the·above·paragraph.¶~~

Commentary on Update: On 9/3/2020 by Bobby Bull.

Date of presentation:

- 326.2 – Key Sheet

• **326.2 → Key Sheet**

The Key Sheet is the first sheet in the component plans set. The location map and Contract Plans Components list are not required on this sheet. Show the Index of Lighting Plans on the left side of the sheet. Assemble lighting plans in the following order:

- (1) → Key Sheet
- (2) → Signature Sheet (if required)
- (3) → Summary of Pay Items (when lead component)

326-Lighting Plans →

Topic #625-000-002 →
FDOT Design Manual

- (4) → Tabulation of Quantities
- (5)(3) → General Notes (if required)
- (6)(4) → Lighting Data Table and Legend
- (7)(5) → Lighting Plan
- (8)(6) → Foundation Details -- High Mast (if required)
- (9)(7) → Boring Data -- High Mast (if required)

Modification for Non-Conventional Projects:

Delete Item (3) from the above list.

Commentary on Update: On 8/19/2020 by James McGinnis and on 9/4/2020 by Bobby Bull.

Date of presentation:

- 326.4 – Tabulation of Quantities and Standard Notes

326.4 Tabulation of Quantities and Standard Notes

~~The Tabulation of Quantities Sheets and Pay Item Notes are no longer produced for projects beginning in January 2021. See **FDM 902** for guidance.~~

~~The Tabulation of Quantities sheet lists the item numbers, description and quantity of materials. List pay items in numerical order. Provisions must be made to show the original and final quantities per sheet or by station. When the number of pay item columns exceed one page, the additional sheet is to be numbered using an alphabetic suffix; e.g., L-3 and L-3A, L-4 and L-4A.~~

~~When there is not a roadway component, see **Chapter 8** of the **Basis of Estimates Manual FDM 307.1** for placing Summary of Quantities sheets in the Lighting plan set.~~

~~On contracts with multiple Financial Project ID numbers, or Federal Aid and non-Federal Aid quantities, provisions must be made to tabulate and summarize their respective quantities.~~

~~Place pay item notes and standard notes that refer to item numbers on this sheet.~~

Modification for Non-Conventional Projects:
Delete FDM 326.4.

Commentary on Update: Added text to create consistency between 325.6.1, 326.7.1, 327.6.1 & 328.6.1

Date of presentation: 7/16/2020 via e-mail per William Summers & Shawn Lewis

- 326.7.1 – Required Information

326.7.1 Required Information

The basic information pertaining to roadway geometrics and project limits required on the lighting plan sheets is the same as that required on the plan portion of the roadway plan-profile sheets. Topography and construction details need not be shown. **Show underground and overhead utilities, signing structures, signal structures and ITS structures that may cause construction conflicts with signallighting components.** Check utilities, drainage, signal structures, sign structures, landscape features, sidewalks, and driveways for conflicts. Identify those that may cause conflicts in the plans.

FDM 327 (Signalization Plans)

Commentary on Update: Revisions made to address the Estimated Quantity Report

Date of presentation:

- 327.1 – General

327-Signalization Plans¶

▪

▪ 327.1 → General¶

Signalization plans include construction details, electrical circuits, signal phasing, and other data relevant to signalization projects.¶

Signalization plans are usually a component set of plans. Component plans are assembled as a separate plan set complete with a Key Sheet, ~~Tabulation of Quantities~~ and all other required signalization sheets. Number the component plans with sheet numbers prefixed by the letter "T"; e.g., T-1, T-2, T-3.¶

~~Modification for Non-Conventional Projects:¶~~

~~Delete the second sentence from the above paragraph and replace with the following:¶~~

~~Component plans are assembled as a separate plan set complete with a Key Sheet and all other required signalization sheets.¶~~

Projects with minimal signalization improvements may show these features on signalization sheets included in the roadway plan set (lead component), or detailed on the Roadway Plan sheets. Do not use the prefix letter "T" when including signal sheets in the roadway plan set. ~~See FDM 307.1 for placing Tabulation of Quantities sheet in the Roadway plan set.¶~~

~~Modification for Non-Conventional Projects:¶~~

~~Delete the last sentence from the above paragraph.¶~~

Commentary on Update: Revisions made to address the Estimated Quantity Report

Date of presentation:

- 327.2 – Key Sheet

327.2 → Key-Sheet

The Key-Sheet is the first sheet in the component plans set. The location map and Contract Plans Components list are not required on this sheet. Show the Index of Signalization Plans on the left side of the sheet. Assemble signalization plans in the following order:

- (1) → Key-Sheet
- (2) → Signature-Sheet (if required)
- ~~(3)~~ → Summary of Pay Items (when lead component)
- (4) → Tabulation of Quantities
- ~~(5)~~~~(3)~~ → General Notes
- ~~(6)~~~~(4)~~ → Signalization Plan
- ~~(7)~~~~(5)~~ → Interconnect/Communication Plan
- ~~(8)~~~~(6)~~ → Mast Arm Details
- ~~(9)~~~~(7)~~ → Foundation Details - Mast Arms
- ~~(10)~~~~(8)~~ → Boring Data Sheets - Mast Arms

Modification for Non-Conventional Projects:
Delete Item (3) from the above paragraph.

Commentary on Update: On 8/19/2020 by James McGinnis

Date of presentation:

- 327.4 – Tabulation of Quantities and Standard Notes

Topic #625-000-002	→	¶
FDOT Design Manual	→	¶
<hr/>		
. 327.4 → Tabulation of Quantities and Standard Notes¶		
The Tabulation of Quantities Sheets and Pay Item Notes are no longer produced for projects that beginning the design phase in January 2021. See FDM 902 for guidance. ¶		
The Tabulation of Quantities sheet lists the item numbers, description and quantity of materials. List pay item numbers in numerical order. Provisions must be made to show the original and final quantities per sheet or by station. ¶		
When there is not a roadway component, see Chapter 8 of the Basis of Estimates Manual FDM 307.1 for placing place Summary of Quantities sheets in behind the Signalization plan set. ¶		
On contracts with multiple Financial Project ID numbers, or federal aid and non Federal Aid quantities, provisions must be made to tabulate and summarize their respective quantities. ¶		
Place pay item notes and standard notes that refer to item numbers on this sheet. ¶		
+	Modification for Non Conventional Projects:α	
	Delete FDM 327.4α	

Commentary on Update: Added "utilities" to create consistency between 325.6.1, 326.7.1, 327.6.1 & 328.6.1

Date of presentation: 7/16/2020 via e-mail per William Summers & Shawn Lewis

- 327.6.1 – Required Information

327.6.1 Required Information

The basic information requirements include roadway geometrics, street names, construction stationing or milepost, curb and gutter, drainage inlets, sidewalks and R/W lines as similarly required on the plan portion of the Roadway Plan-Profile sheets. Show underground and overhead utilities, signing structures, and lighting structures that may cause construction conflicts with signal components. Check utilities, signing and pavement marking features, drainage, landscape features, sidewalks, and driveways for conflicts. Identify those that may cause conflicts in the plans.

Label all equipment shown with their respective pay item numbers ~~and quantity indicated.~~

Modification for Non-Conventional Projects:

Delete the above sentence and replace with the following:

Label all equipment shown.

Commentary on Update: On 9/4/2020 by Bobby Bull.

Date of presentation:

- 327.7 – Interconnect/Communication Plan Sheet

The basic plan information requirements include roadway schematic, showing cross streets and driveways, cable information, pole location, pole number, utility pole identification number, ~~and~~ pay item number ~~and quantity.~~

FDM 328 (Intelligent Transportation Systems (ITS) Plans)

Commentary on Update:

Date of presentation:

- 328.1 – General

328.1 → General¶¶

Intelligent transportation systems (ITS) plans include construction details, electrical circuits, and other data relevant to ITS projects. The following are some of the different systems that may be produced:¶¶

- (1) → Freeway Management System,¶¶
- (2) → Incident Management System,¶¶
- (3) → Arterial Management System,¶¶
- (4) → Emergency Management Systems,¶¶
- (5) → Transit Management Systems,¶¶
- (6) → Electronic Toll Collection,¶¶
- (7) → Electronic Fare Payment,¶¶
- (8) → Highway-Rail Intersections (under electronic surveillance), and¶¶
- (9) → Regional Multimodal Traveler Information¶¶

ITS plans are usually a component set of plans. Component plans are assembled as a separate plans set complete with a Key Sheet, Tabulation of Quantities and all other required ITS sheets. Number the component plans with sheet numbers prefixed by the letter "IT"; e.g., IT-1, IT-2, IT-3.¶¶

~~Modification for Non-Conventional Projects:¶~~

~~Delete the second sentence from the above paragraph and replace with the following:¶¶~~

~~Component plans are assembled as a separate plans set complete with a Key Sheet and all other required ITS sheets.¶~~

Projects with minimal ITS improvements may show these features on ITS sheets included in either the roadway or signalization plan set or detailed on the Roadway or Signalization Plan sheets. Do not use the prefix letter "IT" when including ITS sheets in the roadway plan set. Use the prefix letter "T" when including ITS sheets in the signal plan set. See FDM 307.1 for placing Tabulation of Quantities sheet in the Roadway plan set. Place the ITS Tabulation of Quantities sheet behind the Signal Tabulation of Quantities sheet when including ITS sheets in the signal plan set.¶¶



Commentary on Update: On 9/3/2020 by Bobby Bull

Date of presentation:

- 328.2 – Key Sheet

▪ **328.2 → Key Sheet¶¶**

The Key Sheet is the first sheet in the component plans set. The location map and Contract Plans Components list are not required on this sheet. Show the Index of ITS Plans on the left side of the sheet. Assemble ITS plans in the following order:¶¶

- (1) → Key Sheet¶¶
- (2) → Signature Sheet (if required)¶¶
- ~~(3)~~ → Summary of Pay Items (when lead component)¶¶
- ~~(4)~~ → Tabulation of Quantities¶¶
- ~~(5)~~~~(3)~~ → General Notes¶¶
- ~~(6)~~~~(4)~~ → ITS Plan Sheets or “letter type” plan sets¶¶
- ~~(7)~~ → Detail Sheets (as required)¶¶

→ Modification for Non-Conventional Projects:□
→ Delete Item (3) from the above list.□

~~(5)~~ → ITS plans may require insertion of sheets that were prepared early, or prior to the design process; i.e. early works. See **FDM 302.6.1** for instructions on including early works sheets.¶¶

Commentary on Update: On 8/19/2020 by James McGinnis and on 9/3/2020 by Gevin McDaniel.

Date of presentation:

- 328.4 – Tabulation of Quantities and Standard Notes

<p>328.4 Tabulation of Quantities and Standard Notes</p> <p>The Tabulation of Quantities Sheets and Pay Item Notes are no longer produced for projects that begin the design phase ning in January 2021. See FDM 902 for guidance.</p> <p>The Tabulation of Quantities sheet lists the item numbers, description and quantity of materials. List pay item numbers in numerical order. Provisions must be made to show the original and final quantities per sheet.</p> <p>When there is not a roadway component, see Chapter 8 of the Basis of Estimates Manual FDM 307.1 for placing the Summary of Quantities sheets in behind the ITS plan set.</p> <p>Place pay item notes and standard notes that refer to item numbers, description of work to be performed and quantity estimates on this sheet. If space is limited, notes may be shown on a General Notes sheet.</p> <p>On contracts with multiple Financial Project ID numbers, or federal aid and non-Federal Aid quantities, provisions must be made to tabulate and summarize their respective quantities.</p> <table border="1"><tr><td>Modification for Non-Conventional Projects:</td></tr><tr><td>Delete FDM 328.4.</td></tr></table>	Modification for Non-Conventional Projects:	Delete FDM 328.4.
Modification for Non-Conventional Projects:		
Delete FDM 328.4.		

Commentary on Update: Added “utilities” to create consistency between 325.6.1, 326.7.1, 327.6.1 & 328.6.1

Date of presentation: 7/16/2020 via e-mail per William Summers & Shawn Lewis

- 328.6.1 – Required Information

<p>328.6.1 Required Information</p> <p>The basic information requirements include roadway geometrics, project limits, street names, construction stationing or milepost, curb and gutter, drainage inlets, sidewalks and right of way lines as similarly required on the plan portion of the roadway plan-profile sheets. Show underground and overhead utilities, signing structures, and lighting structures that may cause construction conflicts with ITS components. Check <u>utilities</u>, drainage, landscape features, sidewalks, and driveways for conflicts. Identify those that may cause conflicts in the plans.</p>
--

Clearly label all equipment shown on the plan with their respective pay item numbers and quantities indicated. In addition, the following plan elements should be shown:

Modification for Non-Conventional Projects:

Delete the above paragraph and replace with the following:

Clearly label all equipment shown on the plan. In addition, the following plan elements should be shown:

FDM 329 (Landscape Plans)

Commentary on Update: On 8/13/2020 by Bobby Bull

Date of presentation:

- 329.1 – General

Landscape refers to any vegetation, mulches, and irrigation systems. Designs may include hardscape features (e.g., street furniture, specialty paving, tree grates, walls, planters, fountains, fences, landscape lighting). Hardscape-only projects are not landscape projects. Landscape may be constructed as a standalone project or as a component of a roadway project.

The Legislature ~~has requested~~ requires that the Department commit program dollars to purchase plant materials from Florida commercial nursery stock. In order for the Department to capture that information, it is critical that all small and large plant pay items be placed in ~~AASHTOWare~~ Project Preconstruction™ (formerly TRNS*PORT) Category 0600.

Landscape Plans can be prepared as either a component set of plans, or as a standalone Landscape plans set. Landscape Plans are assembled as a separate plan set complete with a Key Sheet, ~~Tabulation of Quantities~~, and all other required landscape sheets. When prepared as a component set of plans, number the sheets with the prefix "LD"; e.g., LD-1, LD-2, LD-3. When prepared as a Standalone Landscape plan set, the prefix is not needed.

~~Modification for Non-Conventional Projects:~~

~~Delete the second sentence from the above paragraph and replace with the following:~~

~~Component plans are assembled as a separate plans set complete with a Key Sheet and all other required landscape sheets.~~

Projects with minor landscaping may show these features on landscape plan sheets in the roadway plans set (lead component), or detailed on Roadway Plans sheets. Do not use the prefix letter "LD" when including landscaping sheets in the roadway plan set. When there is not a roadway component, place the Summary of Quantities sheets behind the Landscape plan set.

See **FDM 307.1** for placing Tabulation of Quantities sheet in the Roadway plan set.

Commentary on Update: Change made 1/29/2020 by Darrell Lewis and again on 8/13/2020 by Rob Cotleur

Date of presentation: 1/22/2020 via e-mail per Vivian Lemus to address the order of sheets

- 329.2 – Key Sheet

329.2 Key Sheet
<p>The key sheet is the first sheet in the component plans set, or a Standalone Landscape plan set. When used as a component set of plans, the location map and Contract Plans Components list are not required on this sheet. Show the index of Landscape Plans on the left side of the sheet. Assemble the Landscape Plans in the following order:</p>
<p>(1) Key Sheet</p>
<p>(2) Signature Sheet (if required)</p>
<p>(3) Project Layout General Notes</p>
<p>(4) General Notes Plant Schedule</p>
<p>(4)(5) Project Layout</p>
<p>(5)(6) Landscape Plan</p>
<p>(6)(7) Landscape Details</p>
<p>(7)(8) Irrigation Plan (if applicable)</p>
<p>(9) Irrigation Details (if applicable)</p>
<p>(8) Tabulation of Quantities and Plant Schedule</p>
<p style="color: red;">Modification for Non Conventional Projects:</p>
<p style="color: red;">Delete item (9) from the above list.</p>
<p>See FDM 302 for other Key Sheet requirements and Exhibit 302-3 as an example Component Key Sheet.</p>
<p>For Standalone Landscape plan sets, refer to Exhibit 302-1 for an example of a lead Key Sheet with no revisions and Exhibit 302-2 for a lead Key Sheet with Revisions. Assemble Standalone Landscape plans in the following order:</p>
<p>(1) Key Sheet</p>
<p>(2) Signature Sheet</p>
<p>(3) Summary of Pay Items</p>
<p>(3) General Notes</p>
<p>(4) Plant Schedule</p>
<p>(4)(5) Project Layout</p>
<p>(5) General Notes</p>

(6)	Selective Clearing and Grubbing Plan (if applicable)
(7)	Tree Disposition Plan (if applicable)
(8)	Tree Disposition Charts (if applicable)
(8)(9)	Landscape Plan
(9)(10)	Landscape Details
(10)(11)	Irrigation Plan
(11)(12)	Irrigation Details
(12)(13)	Temporary Traffic Control Plan (if applicable)
(13)(14)	Stormwater Pollution Prevention Plan (if applicable)
(14)	Tabulation of Quantities and Plant Schedule
(15)	Irrigation Tabulation of Quantities
(16)(15)	Summary of Quantities

Modification for Non-Conventional Projects:

Delete Items (3), (14), (15), & (16) from the above list.

Commentary on Update: On 8/19/2020 by James McGinnis

Date of presentation:

- 329.4 – Tabulation of Quantities and Plant Schedule

329.4 ~~Tabulation of Quantities~~ and Plant Schedule

The Tabulation of Quantities Sheets are no longer produced for projects that beginning the design phase in January 2021. See **FDM 902** for guidance.

The ~~Tabulation of Quantities and~~ Plant Schedule sheet tabulates the planting materials, landscape soil work, and other materials required for the installation of plant materials. Prepare this sheet using the standard tabulation of quantities sheet as illustrated in Exhibit 329-1. If irrigation elements are included, a separate ~~Tabulation of Quantities Plant Schedule~~ is required. If hardscape elements are included, use the appropriate summary boxes a plant schedule containing information for each element, and include on Summary of Quantities sheets.

Standalone Landscape plan sets may require additional summary tables, depending on the scope of the project; e.g., mowing, litter pickup, outdoor advertising.

When completing the Estimated Quantities Report per **FDM 902**, use the following Pay Size categories: On contracts with multiple Financial Project ID numbers or Federal Aid and non-Federal Aid quantities, provisions must be made to tabulate and summarize their respective quantities.

Modification for Non-Conventional Projects:
Delete FDM 329.4 the last paragraph.

Commentary on Update: On 8/12/2020 by Rob Cotleur

Date of presentation:

- 329.5 – General Notes

329.5	General Notes
Show general notes on a separate General Notes sheet. See FDM 311 for instructions in creating a General Notes sheet. General Notes can be used to describe site-specific requirements, such as:	
<ul style="list-style-type: none">• Watering schedule• Fertilizer mix• Fertilizer schedule• Backfill or soil amendments• Utility providers list• Sight line and/or design speed criteria• Maintaining authority contact information	

Commentary on Update:

Date of presentation:

- 329.6 – Landscape Plan Sheets

Topic #625-000-002	→	¶
FDOT Design Manual	→	¶
Place a north arrow and scale in a conspicuous location, typically in the upper right portion of the sheet. Place a north arrow and scale at a point of maximum visibility on the sheet.		
If two plans are "stacked" on one sheet, include a north arrow and scale in each plan portion.¶		

Commentary on Update: On 8/12/2020 by James McGinnis

Date of presentation:

- 329.6.1 – Required Information

Where necessary, required sheet elements may be “screened” to provide legibility for the landscape plans, so long as the required elements remain apparent.

Planting plan sheets must also provide at a minimum the plant symbols, ~~plant quantities, and~~ common ~~name,~~ and botanical names of each plant.

~~Modification for Non-Conventional Projects:~~

~~Delete the above paragraph and replace with the following:~~

~~Planting plan sheets must also provide at a minimum the plant symbols, common name and botanical name of each plant.~~

Include the following on the planting plan sheets:

- Hardscape and site amenities; e.g., street furniture, specialty paving, tree grates, walls, planters, fountains, fences, and lighting (excluding public utility street and area lighting).
- Location and depth to improve soil structure (a.k.a., soil scarification), amend existing soil, or replace existing soil with Landscape Soil
- Soil scarification and amendment requirements may be described on the General Notes sheet if they are simple. Detailed requirements (e.g., those that vary for specific areas) should be described separately for each amendment type. Each type of soil scarification, amendment, or replacement should be defined (e.g., Type ‘A’), specified, and quantified on the ~~Tabulation of Quantities Sheet~~ **Plant Schedule**.

FDM 330 (Utility Work by Highway Contractor Agreement Plans)

Commentary on Update: On 7/30/2020 by James McGinnis

Date of presentation:

- 330.1 – General

330.1 → General¶

Most utility adjustment work is performed by the utility owners or their contractor. In some cases, it is advantageous to the Department and Utility to include the utility work as part of the roadway contract. In such cases the Department will enter into an agreement with a Utility for this purpose. These agreements are called Utility Work by Highway Contractor (UWHC) Agreements. The highway contractor is required to construct or relocate the specified utilities in accordance with the plans and special provisions developed by the Utility and incorporated as part of the bid package.¶

Typically, utility projects are included as strung projects. There are times when a utility company may reject the bid amount for their project. As a separate set of plans, the quantities and cost can be readily extracted from the contract.¶

Occasionally utility work may extend outside the normal construction limits of the project. When this is the case the limits of the utility work must be shown or noted on the plans.¶

For UWHC Agreements, prepare the utility plans in the same basic format as Department plans and as a separate plans set. Assemble the plans as follows:¶

(1) → Key Sheet¶
 (2) → Signature Sheet (if required)¶
 (3) → Tabulation of Quantities¶
 (4)(3) → Plan-Profile Sheets¶
 (5)(4) → Cross Sections (as required)¶
 (6)(5) → Detail Sheets (as required)¶

Commentary on Update: On 7/30/2020 by James McGinnis

Date of presentation:

- 330.2 – Key Sheet

Refer to the ~~Work Program Instructions (Part III)~~ **Work Program Instructions** for guidance on the Financial Project ID phase number identification.

330.3 Signature Sheet

Commentary on Update: On 8/19/2020 by James McGinnis

Date of presentation:

- 330.4 – Tabulation of Quantities

330.4 → Tabulation of Quantities¶

~~The Tabulation of Quantities Sheets are no longer produced for projects that beginning the design phase in January 2021. See **FDM-902** for guidance. ¶~~

~~Prepare the tabulation of quantities sheet in standard FDOT format and show any quantities tabulated for location, size, and quantity. Standard notes referring to item numbers must also be shown on this sheet or on plan sheets. ¶~~

~~When there is not a roadway component, see **FDM-307.1** for placing place the Summary of Quantities sheets in behind the UWHC plan set. ¶~~

~~Summary of pay item sheets will be prepared as noted in **FDM-304**. ¶~~

~~Modification for Non Conventional Projects: ¶~~

~~Delete **FDM-330.4**. ¶~~

Commentary on Update: Per conversation with the Utility Section

Date of presentation:

- 330.5 – Plan Sets

330.5 → Plan Sheets¶

Utility plans must show full construction details for all utilities to be relocated or constructed by the contractor as covered by the UWHC Agreement. A plan-profile sheet format should be utilized where appropriate. Show all underground utilities in the plan portion, and those which equal or exceed 4" must also be shown in the profile portion. Show all above-ground Utilities in the plan portion (inclusive of underground connections). ¶

When the construction limits are restricted such as when a power line is above and near a sanitary or water facility, either the facility (overhead lines) must be identified and shown in profile, or the minimum available vertical clearances, along with the type facility, stated on the plans. Show applicable project information similar to that described in **FDM-312**. Show utilities to be relocated or constructed in plan and profile and in accordance with the FDOT CADD Software. The scale used should be the same as that used for the roadway plan-profile sheets. ¶

The disposition and final ownership of any utility infrastructure that is to be removed by the contractor and salvaged must be identified in the plans. Include the address of the Utility/Agency Owner receiving the salvaged utility infrastructure in the [UWHC Agreement plans pay item notes on the Summary of Quantity Sheet](#) (see **FDM-307** and **Exhibit-307-4**). ¶

Revisions incorporated by Bulletin

RDB 20-01: Project Information Signs

- FDM 240.2.2.1

RDB 20-02: Railroad Dynamic Envelope

- FDM 220.2.1.1
- FDM 220.3
- FDM 230.30.1

RDB 20-03: Design Development Documentation Module

- FDM 111.7

RDB 20-04: Revisions to Temporary Traffic Control (TTC) for FY 2020-21

- FDM 240- Standard Plans, 102 Series
- FDM 240.2.1.5
- FDM 240.2.2.5
- FDM 240.2.2.13

RDB 20-04: Revisions to Temporary Traffic Control (TTC) for FY 2020-21

- FDM 240- Standard Plans, 102 Series
- FDM 240.2.1.5
- FDM 240.2.2.5
- FDM 240.2.2.13

RDB 20-05: FDM 124 and FDM 125

- FDM 124 (QA/QC Management Plan)
- FDM 125 (Quality Assurance)

RDB 20-07: Class 5 Coatings

- FDM 215.6

RDB 20-08: Adding Backplates to Existing Traffic Signals

- FDM 114.3.2
- FDM 232.1.5