

## 211 Limited Access Facilities

### 211.1 General

This chapter includes criteria for Limited Access (LA) Facilities (tolled and non-tolled), including:

- (1) Interstates
- (2) Freeways
- (3) Expressways
- (4) Interchange ramps servicing high speed LA Facilities
- (5) Collector-distributor roads (C-D) servicing high speed LA Facilities

Express lanes design is an iterative process best performed in a collaborative environment involving various disciplines e.g. express lanes planning, PD&E, construction, maintenance, traffic operations, transportation systems management and operations (TSM&O), and Turnpike toll operations. An explanation of the process and considerations is given in the ***FDOT Express Lanes Manual***.

Many design criteria are related to design speed; e.g., vertical and horizontal geometry, sight distance. When the minimum design values are not met, an approved Design Exception or Design Variation is required. See ***FDM 201.4*** for information on Design Speed. See ***FDM 122*** for information on Design Exceptions and Design Variations.

The following manuals and documents provide additional information for the design of LA Facilities:

- **[General Tolling Requirements \(GTR\)](#)** -This document is used for design criteria and requirements for tolling on Turnpike and Non-Turnpike projects. This includes “open road” tolling facilities, express lanes (managed lanes, high occupancy tolling lanes, etc.) on new or existing corridors.
- ***AASHTO’s A Policy on Geometric Design of Highways and Streets (AASHTO Green Book)***
- ***A Policy on Design Standards – Interstate System, 2005 Edition (AASHTO)***
- ***Turnpike Design Handbook (TDH)***
- **[FDOT Express Lanes Manual \(FELM\)](#)**
- **[Traffic Engineering Manual \(TEM\)](#)** - This manual is used to supplement the ***Manual on Uniform Traffic Control Devices (MUTCD)***’s standards and

guidelines with Florida specific signs and pavement markings used on the State Highway System by the Department's Traffic Operations Offices.

Example roadway typical sections are included in the exhibits in **FDM 306**. Criteria regarding lanes, medians, and shoulders for bridges are illustrated in **FDM 260.1.1**. Subsequent sections of this chapter contain specific information and criteria regarding these and other typical section elements, as well as geometric features.

Specific requirements for placement of the toll site infrastructure (e.g., tolling equipment structures, equipment buildings, utilities) is given in the General Tolling Requirements ([GTR](#)).

### **211.1.1 Interstate Resurfacing Projects**

Interstate resurfacing projects that do not meet the criteria in this chapter may use the AASHTO interstate standards that were in effect at the time of original construction or inclusion into the interstate system for the following elements:

- horizontal alignment
- vertical alignment
- median width
- traveled way width
- shoulder width

### **211.2 Travel Lanes and Auxiliary Lanes**

Provide 12-foot travel lanes and auxiliary lanes on LA Facilities.

#### **211.2.1 Ramps**

On tangent and large radii (500 ft. or greater) sections, provide a 15-foot traveled way for one-lane ramps and 24-foot traveled way for two-lane ramps

Consider providing a greater lane width for one-lane ramps where accommodation of future resurfacing is a factor.

Ramp widths in other areas such as terminals are controlled by the curvature and the vehicle type selected as the design control. Minimum ramp widths for turning roadways are given in **Table 211.2.1**. Typical details for ramp terminals are provided in the [Standard Plans, Index 000-525](#).

**Table 211.2.1 Minimum Ramp Widths - Turning Roadways**

Radius To Inside of Curve (ft.)	Minimum Ramp Width (ft.)		
	1-Lane		2-Lane
	Case I-C Traveled Way Width	Case II-B Traveled Way Width + Outside Paved Shoulder Width	Case III-A Traveled Way Width
	One-lane, one-way operation – no provision for passing a stalled vehicle	One-lane, one-way operation – with provision for passing a stalled vehicle	Two-lane operation – either one-way or two-way
50	23	26	29
75	20	23	27
100	18	22	26
150	17	21	24
200	16	20	24
300	15	20	24
400	15	19	24
≥ 500	15	19	24

**Notes:**

- (1) For case application, see **AASHTO Green Book**.
  - (a) Case I - Bus and combination trucks govern design.
  - (b) Case II - SU vehicles govern design, some consideration for semitrailer combination trucks.
  - (c) Case III – P vehicles govern design, some consideration for SU trucks.
- (2) **AASHTO** adjustments do not apply.

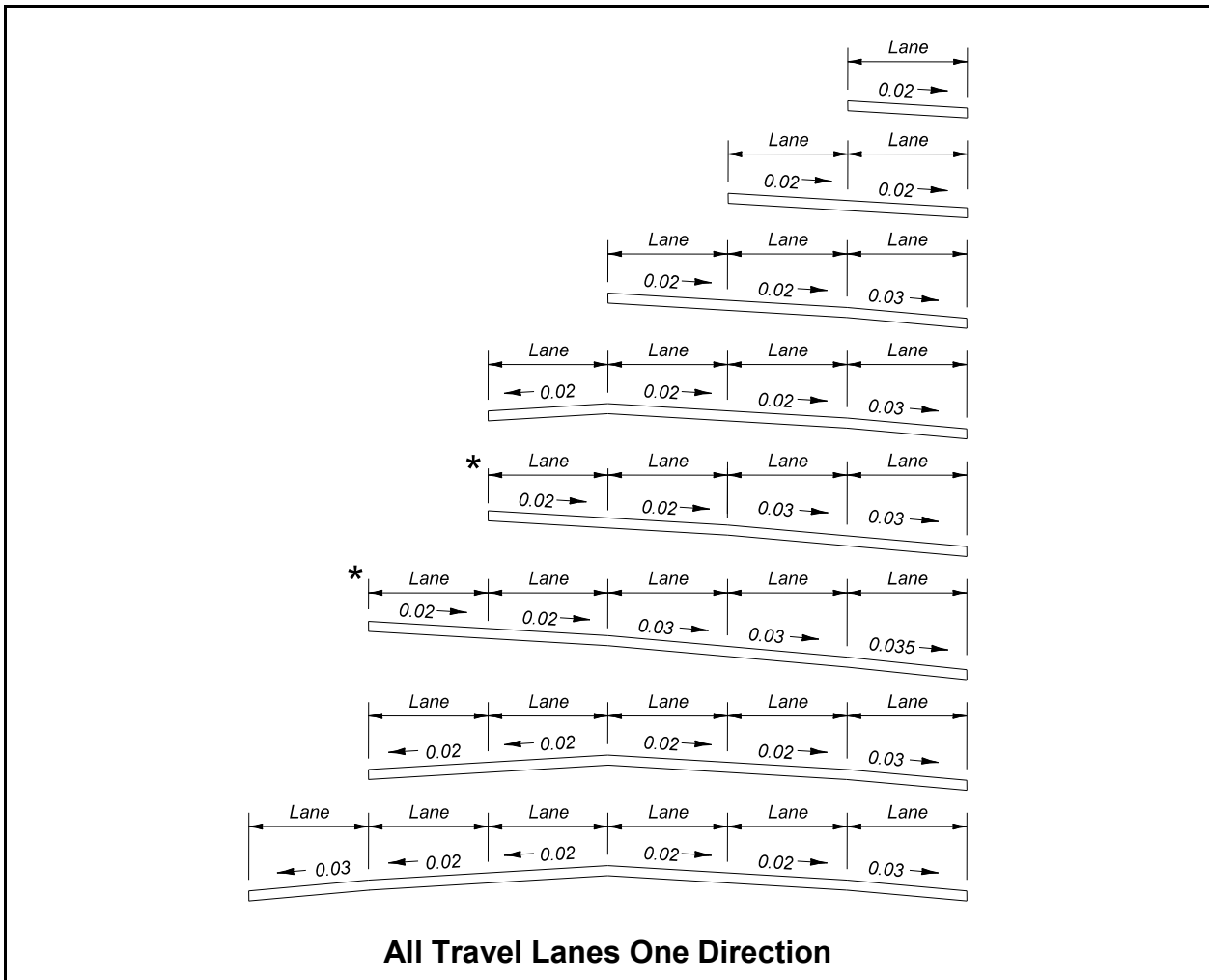
## 211.2.2 Pavement Cross Slopes

For roadways, the maximum number of travel lanes with cross slope in one direction is three lanes except as shown in **Figure 211.2.1**, which prescribes standard pavement cross slopes. A Design Variation or a Design Exception is required when proposed pavement cross slopes do not meet the requirements shown in **Figure 211.2.1**.

The maximum algebraic difference in cross slope between adjacent through lanes is 0.04. The maximum algebraic difference in cross slope between a through lane and an auxiliary lane at a turning roadway terminal is given in **Table 211.2.2**.

Cross slopes on bridges are to be on a uniform, straight-line rate, typically 0.02 (See **FDM 260.4**). Use transitions to adjust for differences in cross slope between the approach roadway section and the required straight-line slope for bridge decks. Whenever possible the transition should be accomplished on the roadway section, outside the limits of the bridge and approach slabs. This will require detailing of the transition(s) in the roadway plans. Coordination between the Roadway, Drainage and Structures designers in the development of transitions is required to ensure compatibility and harmonizing at bridge approaches.

**Figure 211.2.1 Standard Pavement Cross Slopes**

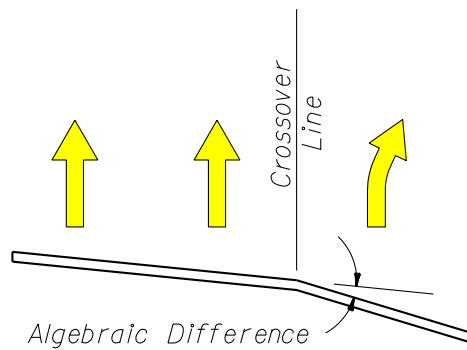
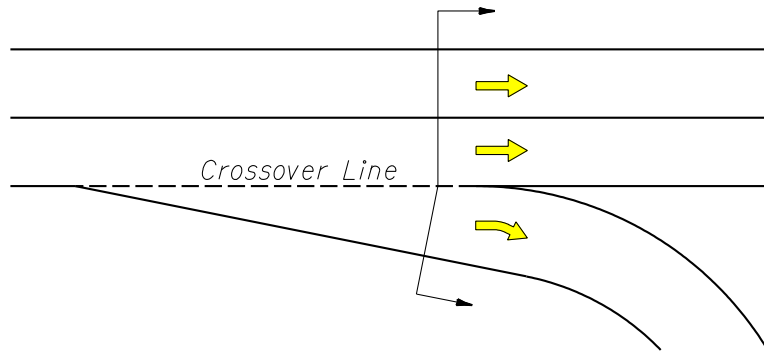


**All Travel Lanes One Direction**

- (1) These sections show only the standard slopes for adjoining travel lanes; they do not prescribe needed lanes, lane usage or typical section requirements other than lane slope.
- (2) Maximum pavement cross slopes for on tangent sections are:
  - (a) 0.03 for design speeds greater than 45 mph
  - (b) 0.035 may only be used for 5-lanes sloped in one direction as shown above for all design speeds.
- (3) The maximum change in cross slope between adjacent through lanes is 0.04.
- (4) 4 or 5 lanes sloped in one direction (\*) may be used with design speed 65 mph or less and longitudinal grades not exceeding 5%.

**Table 211.2.2 Maximum Algebraic Difference in Cross Slope at Turning Roadway Terminals**

Design Speed of Exit or Entrance Curve (mph)	Maximum Algebraic Difference in Cross Slope at Crossover Line (%)
Less than 35	6.0
35 and over	5.0



### 211.2.2.1 Existing Pavement Cross Slopes

Review the existing pavement and shoulder cross slopes for compliance with criteria. Field verify existing pavement and shoulder cross slopes by one of the following:

- (1) Full Digital Terrain Model for the roadway width – evaluate cross slope on tangent sections at 100-foot intervals.
- (2) Vehicle Mounted Scanner – prior to design, using the results of the scan, determine roadway limits where cross slope is potentially out of tolerance and request Digital Terrain Model of the roadway width for these limits. Evaluate cross slope on tangent sections at 100-foot intervals.

If cross slopes do not meet the values in **Table 211.2.3**, additional cross sections may be required by the designer to develop cross slope correction details and estimate material quantities. Resurfaced pavement and shoulder cross slopes should meet new construction criteria. When cross slope correction is not practical, documentation in the design file is required. If existing conditions are within the allowable range shown in **Table 211.2.3**, the term “Match Existing” may be used on the Typical Section(s) to indicate that the existing cross slope is to remain. Superelevation requirements are covered in **FDM 211.8**.

When cross slope correction is necessary, work closely with the District Pavement Design Engineer and the District Bituminous Engineer to determine the appropriate method of correction. Tabulate existing cross slopes in the plans at 100-foot intervals within the limits of cross slope correction. Include cross slope correction details showing the method of correction in the plans (see examples in **FDM 306**). Do not show cross slope correction details on the roadway cross sections. Base cross slope correction material quantities on the method of correction shown in cross slope correction details.

**Table 211.2.3 Allowable Range for Existing Pavement Cross Slopes**

Facility or Feature	Standard (ft./ft.)	Allowable Range (ft./ft.)
Travel Lanes	0.02	0.015 - 0.025
Travel Lanes	0.03	0.025 - 0.035
Outside Shoulder	0.06	Adjacent Lane Cross Slope - 0.080
Median (left) Shoulder	0.05	0.020 - 0.080

**Notes:**

- (1) Standard cross slope (0.02 or 0.03) as designated in **Figure 211.2.1**.
- (2) The algebraic difference in cross slope between adjacent travel lanes must not exceed 0.04. The maximum algebraic difference in cross slope between a through lane and an auxiliary lane at a turning roadway terminal must meet **Table 211.2.2**.
- (3) When existing shoulders are to remain, the algebraic difference between the shoulder slope and adjoining roadway pavement slope must be  $\leq 0.07$ .

### 211.2.3 Hydroplaning Risk Analysis

The hydroplaning risk analysis predicts the water film thickness on the pavement being analyzed and the speed at which hydroplaning may occur. This information may support utilizing a non-compliant typical section when weighed against the cost of correcting pavement cross slope. Coordinate with the District Drainage Engineer to determine whether a hydroplaning analysis is needed.

Modification for Non-Conventional Projects:

Delete last sentence in above paragraph and see RFP for requirements.

When a hydroplaning risk analysis is performed, use the HP Program and the Design Guidance: Hydroplaning Risk Analysis. The Hydroplaning Tools can be downloaded under Design Aids at:

<http://www.fdot.gov/roadway/Drainage/ManualsandHandbooks.shtm>



## 211.2.4 Roadway Transitions

The minimum merging roadway transition length (L) is calculated as follows:

- (1) Use  $L = WS$  for design speeds  $\geq 45$  mph
- (2) Use  $L = WS^2/60$  for design speeds  $\leq 40$  mph

Where: L = length of taper, feet  
W = width of lateral transition, feet  
S = design speed, mph

**Exhibits 210-1** through **210-6** illustrate standard roadway transitions. For conditions not addressed in these figures, use the following:

- Merging Taper = L
- Shifting Taper = L/2
- Shoulder Taper = L/3

Where an abrupt change in roadway typical (e.g., 4-lane section to a 6-lane section) a striped lane transition may be considered when all the following conditions are met:

- New pavement widths are not substantially greater than the joining pavement,
- Grade differentials are slight, and
- Future widening is expected.

## 211.2.5 Number of Lanes on the State Highway System

See **Section 335.02(3)** of the **Florida Statutes** for the number of lanes to be provided on the State Highway System. Nothing in this statute precludes a number of lanes in excess of ten lanes. The Department will determine the appropriate number of lanes based on traffic demand. Consideration will be given to availability of right of way and the capacity to accommodate other modes of transportation within existing rights of way.

**Topic No.: 525-030-020a Capacity Improvement Alternatives** is the Department policy to assist in the identification of the most appropriate option for widening projects on all LA Facilities on the State Highway System (SHS). This policy applies to the Interstate System and to Florida's Turnpike Enterprise facilities.

## 211.3 Medians

Median width is the distance between the inside (median) edge of the travel lane of each roadway. Required median widths are given in **Table 211.3.1**.

Median ditches must be designed to meet the following requirements:

- Have sufficient depth to provide positive drainage of the adjacent sub-grades. Typically this requires a median depth of at least one foot below the sub-grade shoulder point.
- Have recoverable side slopes within the clear zone in order to facilitate the recovery of errant vehicles. See **FDM 215** for additional information on roadside safety.
- Have sufficient longitudinal gradient and hydraulic capacity to ensure good drainage.

**Table 211.3.1 Minimum Median Widths**

Facility Type		Minimum Median Width (ft.)
Interstate, Without Barrier		64
Freeway and Expressway, Without Barrier	Design Speed $\geq$ 60 mph	60
	Design Speed < 60 mph	40
All, With Barrier		26

**Notes:**

(1) For Interstate (without barrier), provide an 88-foot median width when future lanes are planned.

Facilities that have the ability to be expanded for additional capacity in the future will be designed to accommodate that future expansion. For example, a 4-lane high-speed facility that has the potential to expand to a 6-lane facility (without express lanes) may be designed with a 50-foot median with barrier (e.g. guardrail, high tension cable barrier) instead of the required 60-foot median. A 50-foot median will accommodate a future 2-foot concrete median barrier, two 12-foot travel lanes and two 12-foot shoulders.

**Modification for Non-Conventional Projects:**

Delete note (1) from **Table 211.3.1** and delete the above paragraph and see RFP for requirements.

### 211.3.1 Bridge Median

See **FDM 260.5** for information on bridge medians.

### 211.3.2 Median Crossovers

This section addresses permanent median crossovers (i.e., median openings). The criteria in this section does not apply to contra-flow crossovers placed for facilitating hurricane evacuation, nor does it apply to temporary construction crossovers. For temporary construction crossovers, refer to [Standard Plans, Indexes 102-630](#) and [102-631](#).

Permanent crossovers are necessary to avoid excessive travel distances for emergency vehicles, law enforcement vehicles, and maintenance vehicles. Provide median crossovers only when there is a documented request and need for such a feature; however they are to be limited in number and strategically located. The District Design Engineer (DDE) and the District Traffic Operations Engineer (DTOE) jointly approve the location of median openings.

The following **AASHTO Green Book** crossover recommendations have been adopted by the Department as requirements for permanent crossovers:

- (1) Not spaced closer than 3 miles apart.
- (2) Located only in areas with above-minimum stopping sight distance and without superelevated curves.
- (3) Not located within 1,500 feet of the end of a speed-change taper (of a ramp or facility widening/narrowing) or any structure (bridge, overpassing facility or overhead sign).
- (4) Not located where the median width is less than 25 feet.

Crossover locations that do not meet the above criteria require approval by the State Roadway Design Engineer. Non-conforming crossovers on Interstate facilities require approval by the State Roadway Design Engineer and Federal Highway Administration (FHWA).

The following additional FDOT criteria are also requirements for permanent crossovers:

- (1) Not located within 1.5 miles of any interchange.
- (2) Not located where the median width is less than 40 feet.
- (3) Not located in urban areas

- (4) Where continuous median barrier is present, openings for crossovers should not be greater than 5 miles apart between Interchanges.

Typical layouts for the design of median crossovers are provided in **Exhibits 211-1** and **211-2**. These typical layouts may not cover all situations, but are provided as a guide for developing site-specific designs. Designs should accommodate the types of emergency vehicles expected to use the crossover. Law enforcement vehicles and typical ambulance sized vehicles can usually be easily accommodated. The typical layouts illustrated in the exhibits accommodate a SU design vehicle. To the extent practical, designs should accommodate larger emergency response vehicles such as fire trucks. This may require obtaining information from local emergency responders on the size and configuration of vehicles used. Except where median widths are wider than normal, fire trucks and other larger vehicles will likely not be able to make U-turns without encroaching or crossing travel lanes. As a minimum, designs should provide for the necessary minimum radii and width to allow the largest design vehicle to enter the crossover and stop as close to perpendicular to traffic as practical. All designs should be tested by superimposing the turning path of the design vehicle to insure the crossover will operate as expected.

On Interstate facilities, the FHWA directs that median shoulders approaching the crossover utilize the standard shoulder width, or existing shoulder width. FHWA advocates that the safety benefits derived by making the crossovers appear less conspicuous outweigh the benefits obtained by providing paved shoulders to accommodate acceleration and deceleration lanes for emergency vehicles, law enforcement, or other authorized vehicles.

The profile of the crossover is to conform as close as practical with travel way shoulder slopes and median side slopes so that the crossover is inconspicuous as possible to traffic. The paved width of the crossover should not be any wider than that necessary to provide for the largest design vehicle. Shoulder width for the crossover should be 8 feet minimum. Side slopes of the crossover (parallel with the mainline travel way) are to be 1:10 or flatter. However, side slopes may be transitioned to match the slope of a pipe culvert safety end treatment where a culvert crossing underneath the crossover is necessary to provide for proper median drainage.

For each proposed location, determine drainage requirements and make appropriate provisions. The drainage culvert shown in the exhibits are for example only. Either a mitered end section (1:4) or preferably a u-endwall with grate (1:6) should be used for culverts parallel with the mainline. In some cases existing median ditches are shallow and there will be minimal clearances available for even small size culverts.

Provide a pavement design equivalent to a Limited Access shoulder pavement; i.e., 12 inch Stabilized Subgrade, Base Group 1, and 1.5 inch Structural Course.

A "No U-turn" sign (R3-4) with an "Official Use Only" plaque (FTP-65-06) is required for permanent crossovers. To improve nighttime visibility for approaching emergency responders, yellow RPMs are installed on the outside yellow edge line in advance of the crossover. See [Standard Plans](#), **Index 706-001** for RPM placement.

**Florida Administrative Code, Rule 14-97, Section 14-97.003(3)** (Access Control Classification System and Access Management Standards) regulates the location of driveway connections and median openings in interchange areas on arterial roads. This standard should be applied in accordance with the District procedures for implementing the Rule, and should not be confused with minimum requirements for LA R/W.

### 211.3.2.1 Existing Crossovers

On reconstruction and resurfacing projects, evaluate the location of existing crossovers for conformance to the above criteria. For those locations that do not meet the criterion in **FDM 211.3**, do one of the following:

- (1) Remove or relocate crossover as a part of the project
- (2) Crossover locations that do not meet the **AASHTO Green Book** criteria require approval by the State Roadway Design Engineer to remain. Non-conforming crossovers on Interstate facilities require approval by the State Roadway Design Engineer and Federal Highway Administration (FHWA) to remain.
- (3) Crossover locations that meet the **AASHTO Green Book** criteria, but do not meet additional FDOT criteria require approval by the District Design Engineer to remain.

Modification for Non-Conventional Projects:

Delete **FDM 211.3.2.1** and replace with the following:

### 211.3.2.1 Existing Crossovers

Evaluate the location of existing crossovers for conformance to the criteria in **FDM 211.3**. Remove existing crossovers that do not meet this criterion.

### 211.3.3 Express Lanes Separation

Express lanes are always separated from the general use lanes or general toll lanes. Median openings and crossovers are prohibited within express lanes.

There are four types of express lanes separation treatments:

- (1) Barrier separation; see **Figure 211.3.1**
- (2) Buffer separation with express lanes markers; see **Figure 211.3.2**
- (3) Wide buffer separation; see **Figure 211.3.3**
- (4) Grade separation; see **Figure 211.3.4**

The minimum standard buffer width for the buffer separation is 4 feet. Any variation from a 4-foot-buffer width must be approved by the District Design Engineer. Install express lane markers per the [TEM](#), Section 4.2. Use barrier separation or grade separation when implementing a reversible express lane system.

Modification for Non-Conventional Projects:

Delete second sentence in above paragraph and see RFP for requirements.

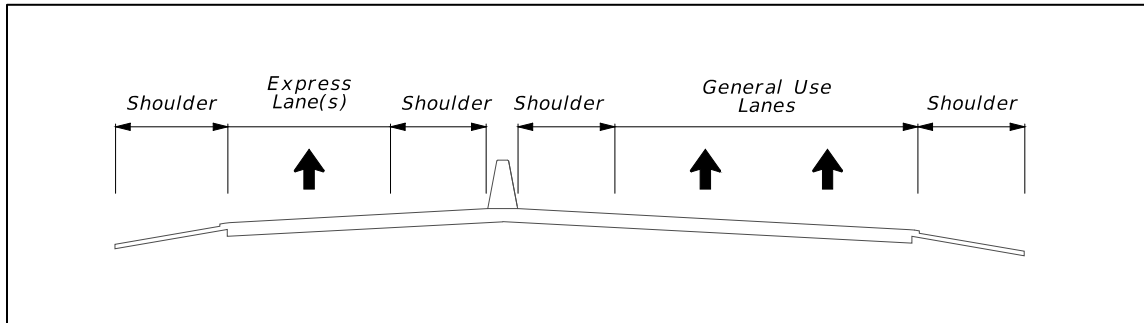
The maximum spacing and placement of express lanes markers is provided in the [TEM](#). If, based on operational and safety analysis, the EOR or the district wishes to increase the maximum allowable spacing, a Design Variation must be approved by the Chief Engineer.

When a wide buffer separation is selected, the buffer may include a grassed median or pavement. Paved wide buffers should be no more than 12 feet wide. Refer to the **FELM** for additional considerations for wide buffer separation.

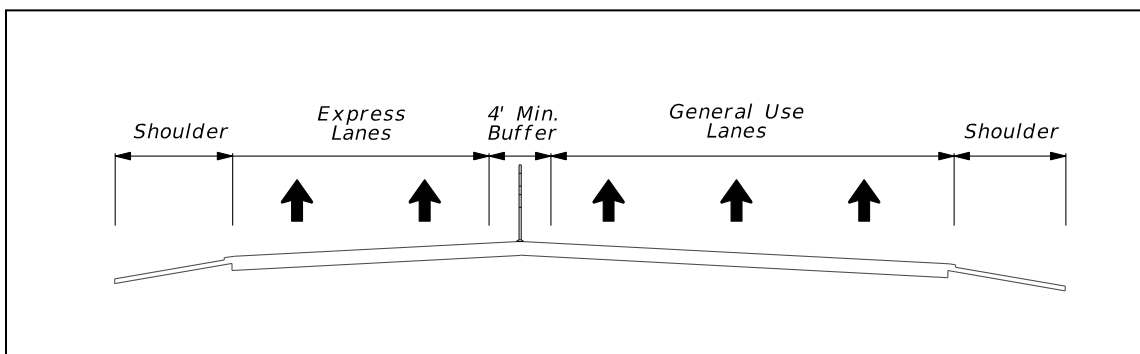
Modification for Non-Conventional Projects:

Delete the last sentence in the above paragraph and see RFP for requirements.

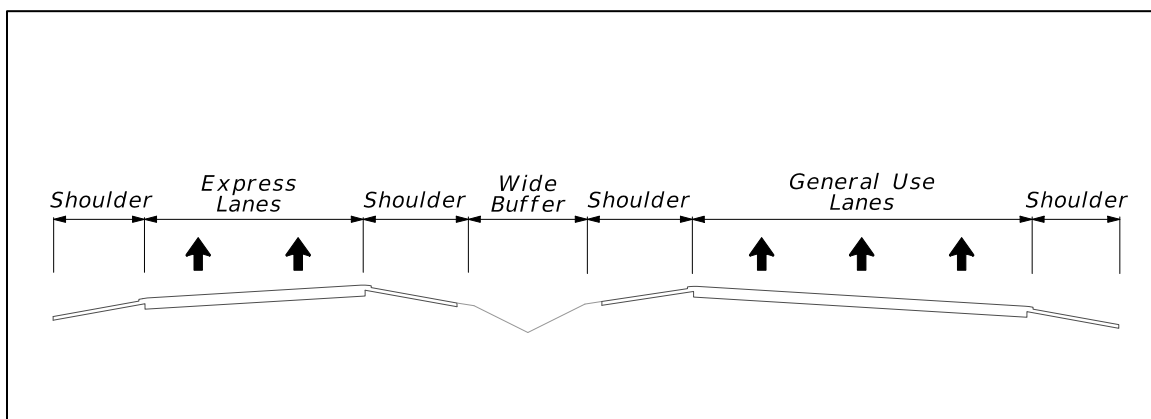
**Figure 211.3.1 Express Lanes Barrier Separation Typical Section**



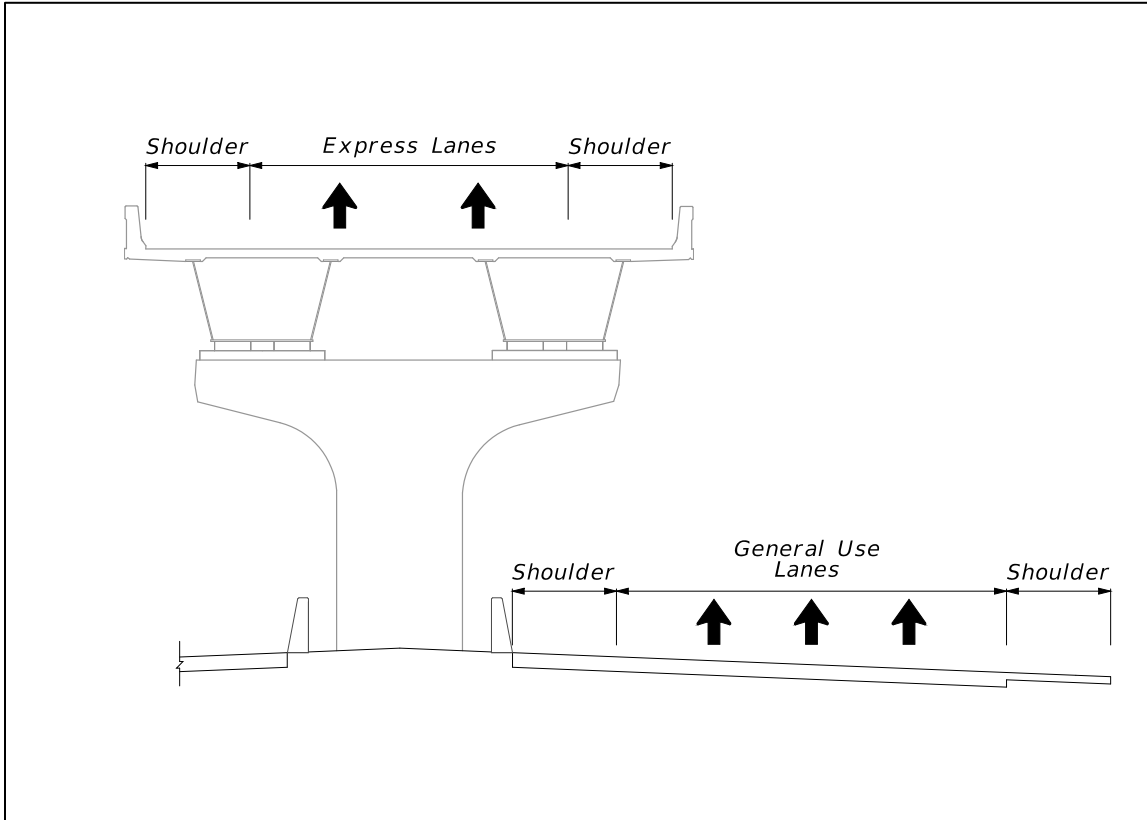
**Figure 211.3.2 Express Lanes Buffer Separation with Express Lanes Marker Typical Section**



**Figure 211.3.3 Express Lanes Wide Buffer Separation Typical Section**

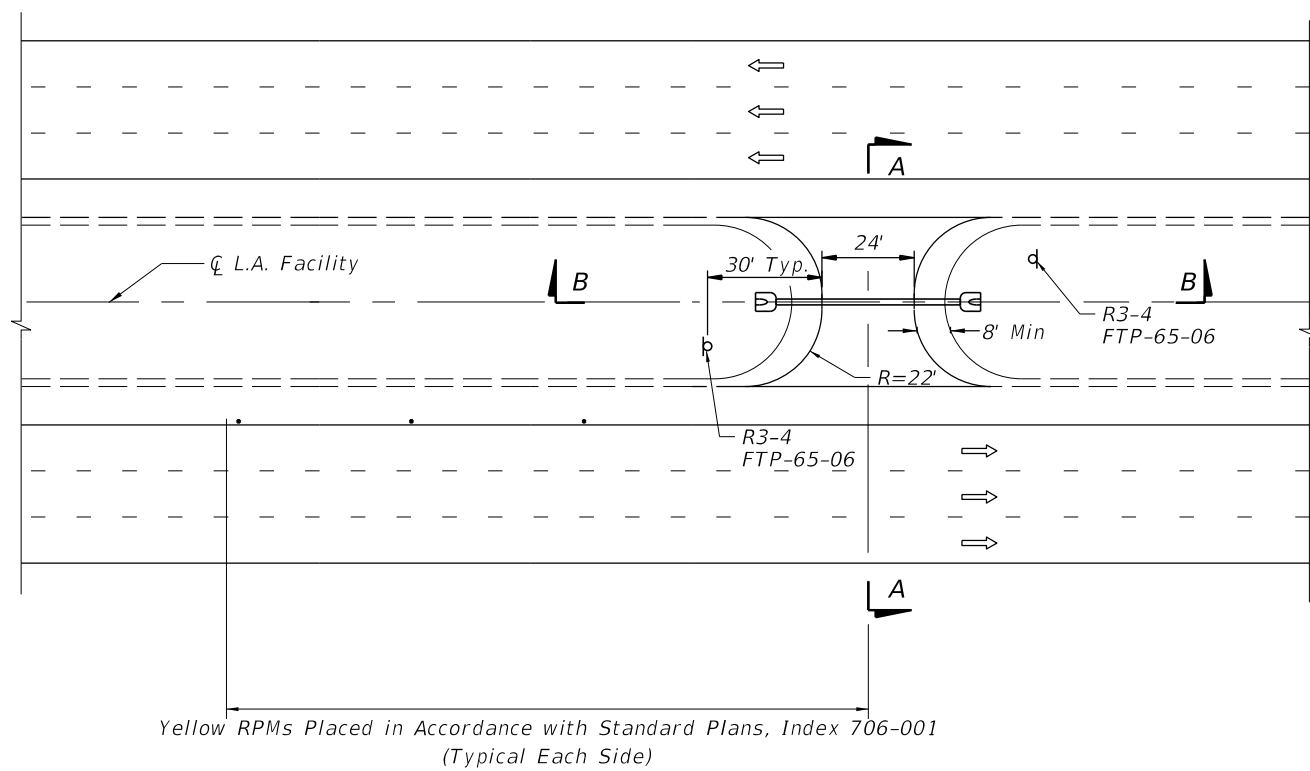


**Figure 211.3.4 Express Lanes Grade Separation Typical Section**

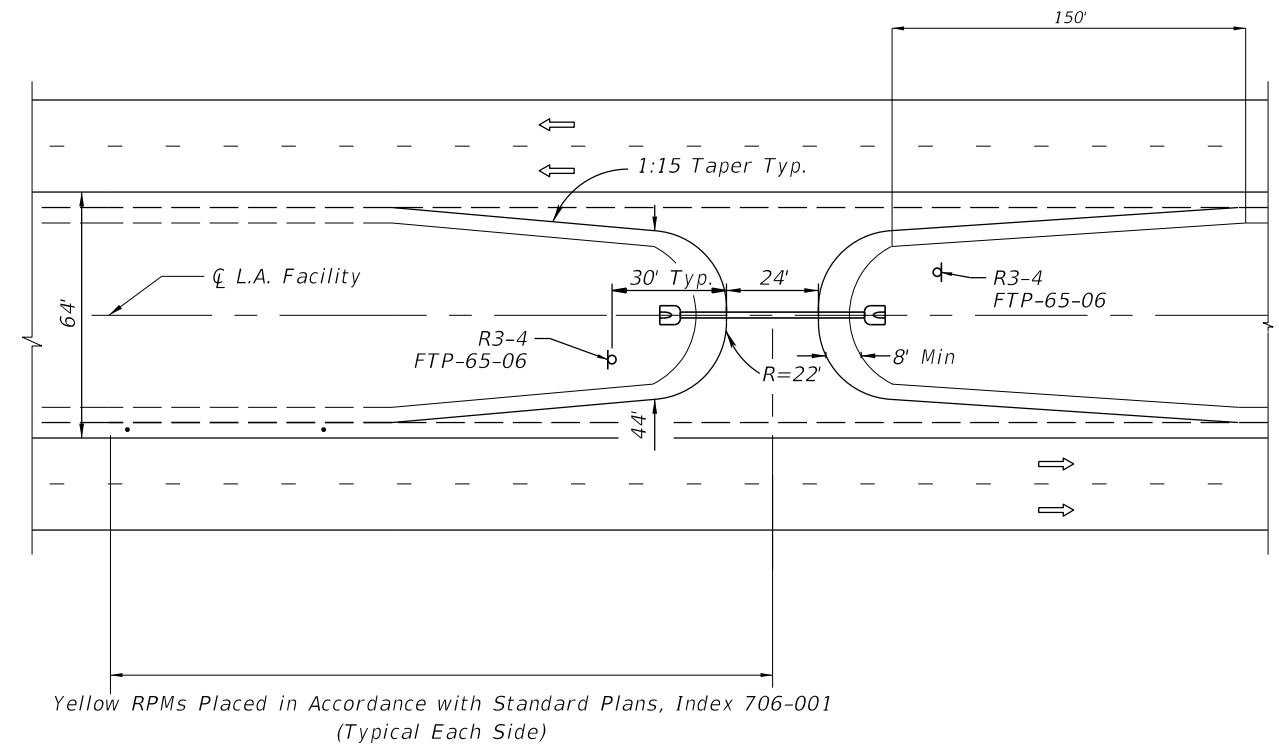




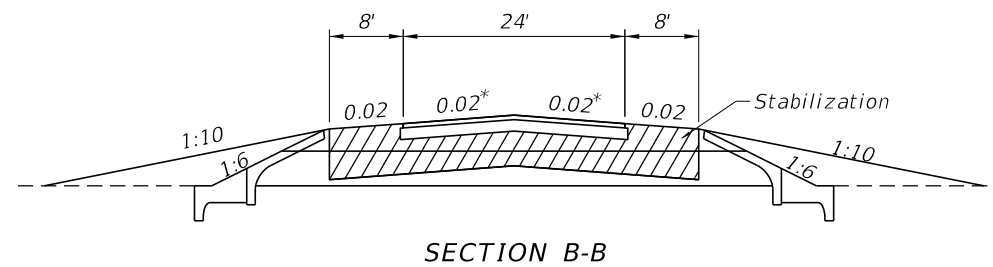
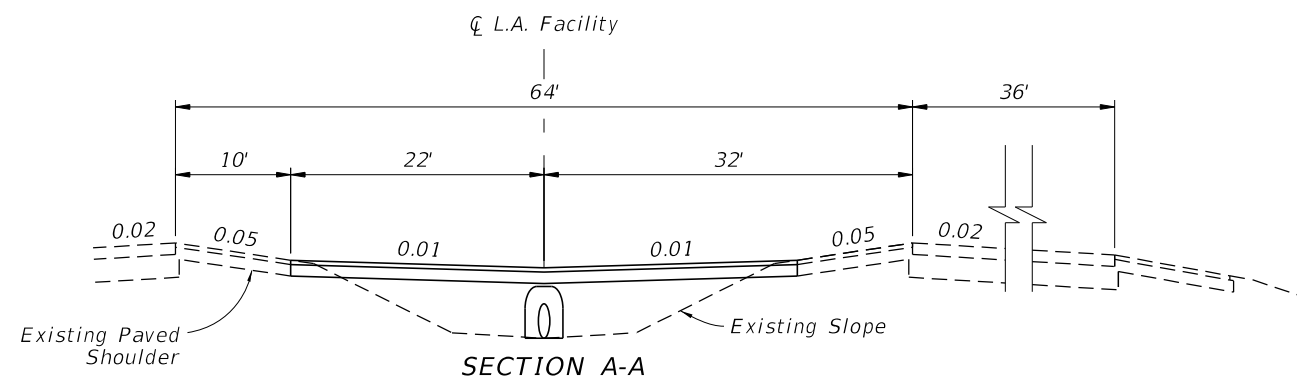
# MEDIAN CROSSOVERS TYPICAL LAYOUTS AND SECTIONS



PLAN VIEW - 6 LANES (OR MORE)



PLAN VIEW - 4 LANES



**LEGEND:**

Ⓟ Sign



R3-4  
(36"x36")



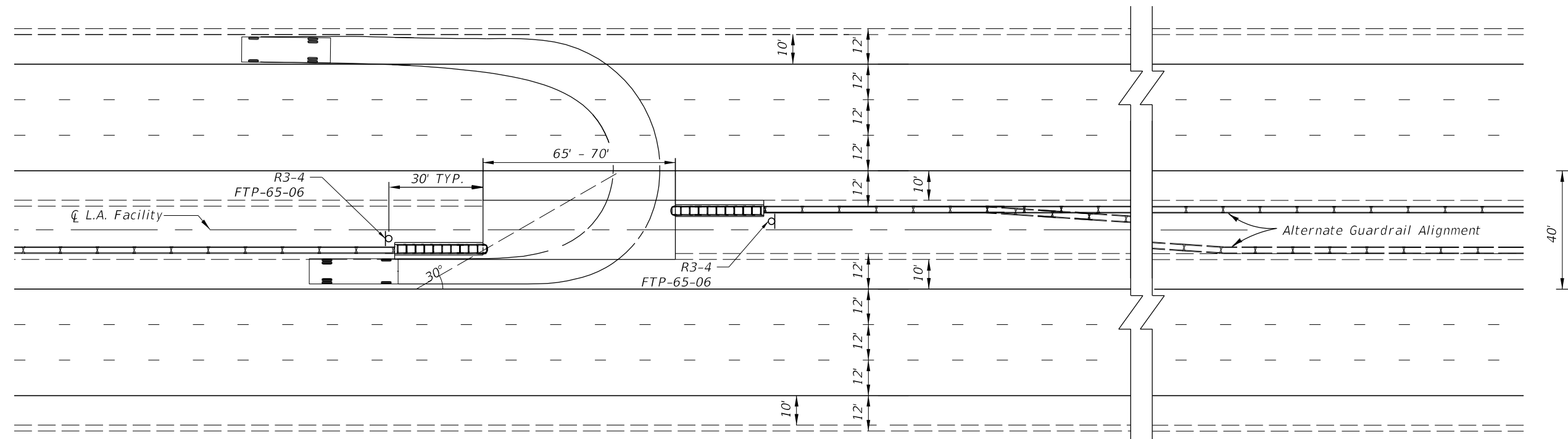
FTP-65-06  
(36"x18")

\* For freeway grades 2% or greater,  
match freeway grade

**NOT TO SCALE**

**EXHIBIT 211-1  
01/01/2018**

# MEDIAN BARRIER OPENING FOR MEDIAN CROSSOVERS TYPICAL LAYOUT




PLAN VIEW

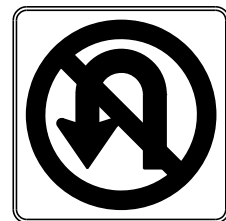
**LEGEND:**

 Crash Cushion

 Barrier

 Sign

 SU Vehicle



R3-4  
(36"x36")



FTP-65-06  
(36"x18")

**NOTES:**

1. Provide Yellow RPMs placed outside yellow edge line in advance of crossover as shown in Standard Plans, Index 706-001.
2. Minimum turning radius for SU vehicle shown, and were generated by AutoTURN.
3. For lane and median configurations other than the 6-lane, 40-foot median shown here, adjustments in turn radii or additional pavement may be required.

**NOT TO SCALE**

**EXHIBIT 211-2**  
01/01/2019

## 211.4 Shoulders

Roadway shoulder width is measured from the edge of the traveled way to the shoulder break. A portion of the shoulder is required to be paved. Required shoulder widths and paved widths are given in **Table 211.4.1**.

Refer to **FDM 260.3** for bridge shoulder widths.

See [General Tolling Requirements \(GTR\)](#) for required paved shoulder width at tolling locations.

### 211.4.1 Express Lanes Shoulders

The required width for express lanes shoulders depends on the type of separation between the express lanes and the general use lanes or general toll lanes. When retrofitting express lanes in constrained conditions, shoulder widths in **Table 211.4.1** may not be achievable without a Design Variation or Design Exception. Consult the [Highway Safety Manual](#) on safety tradeoffs when narrowing shoulder widths.

Modification for Non-Conventional Projects:

Delete second and third sentences in above paragraph and see RFP for requirements.

**Table 211.4.1 Minimum Shoulder Widths**

Minimum Shoulder Width (ft.)									
Lane Type	# Lanes (One Direction)	Without Shoulder Gutter				With Shoulder Gutter			
		Outside or Right		Median Or Left On Divided Roadways		Outside or Right		Median Or Left On Divided Roadways	
		Full Width	Paved Width	Full Width	Paved Width	Full Width	Paved Width	Full Width	Paved Width
Travel Lanes	2-Lane	12	10	8	4	15.5	8	13.5	6
	3-Lane or more	12	10	12	10	15.5	8	15.5	8
Express Lanes	1-Lane	12	12	12	12	13.5	10	13.5	10
	2-Lane	12	12	12	12	13.5	10	13.5	10
Ramps	1-Lane Ramp	6	4	6	2	11.5	4	11.5	4
	2-Lane Ramp Non-Interstate	10	8	8	4	15.5	8	13.5	6
	2-Lane Ramp Interstate	12	10	8	4	15.5	8	13.5	6
C-D Roads	1-Lane	6	4	6	2	11.5	4	11.5	4
	2-Lane	12	10	8	4	15.5	8	13.5	6
	3-Lane or more	12	10	12	10	15.5	8	15.5	8
Aux. Lanes	ALL	12	10	8	4	15.5	8	8	4

**Notes:**

**With shoulder gutter:**

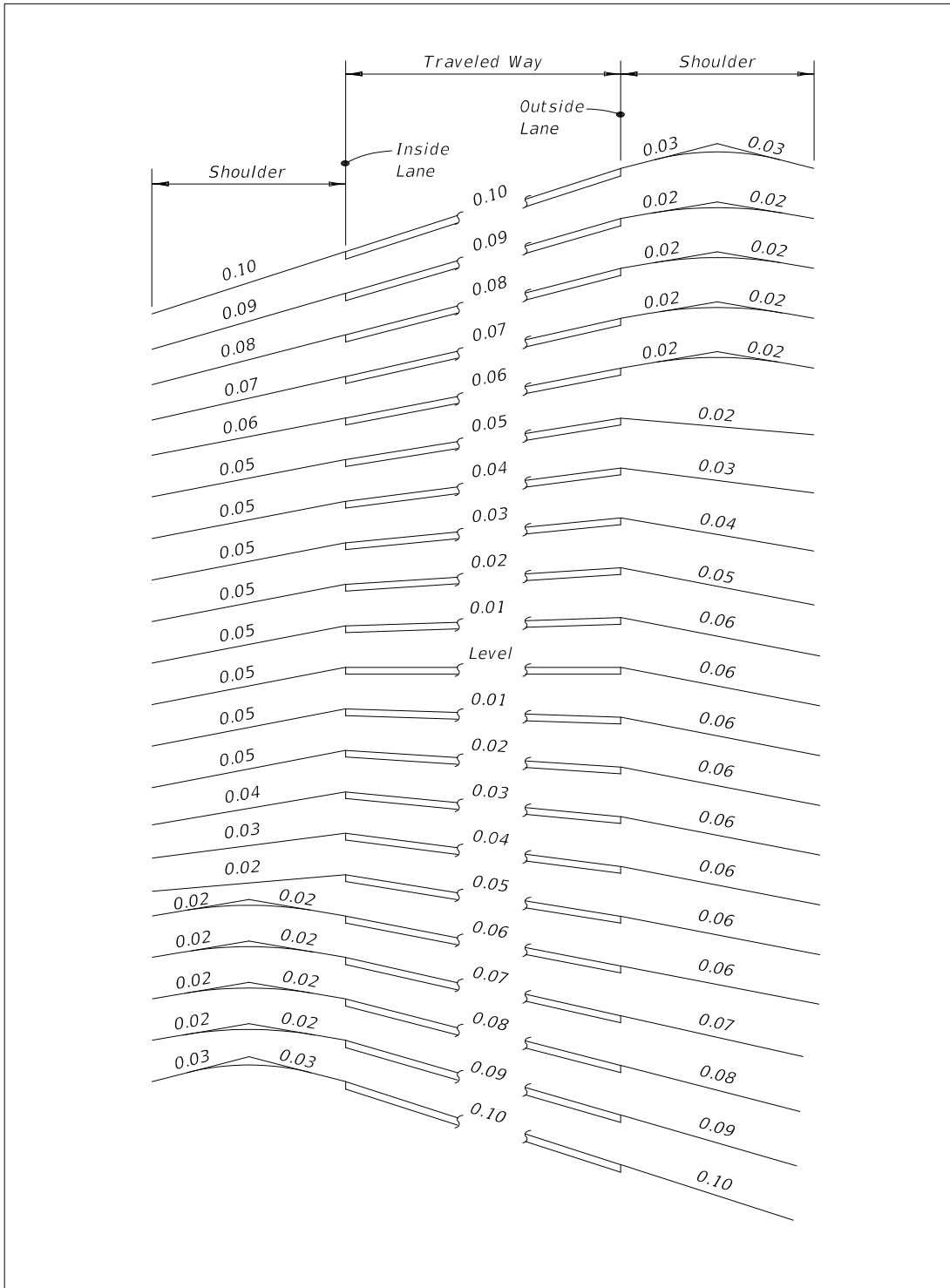
- (1) Ramp shoulder pavement less than 6 feet in width that adjoins shoulder gutter must match the type, depth, and cross slope of the ramp travel lane.

## 211.4.2 Shoulder Cross Slopes

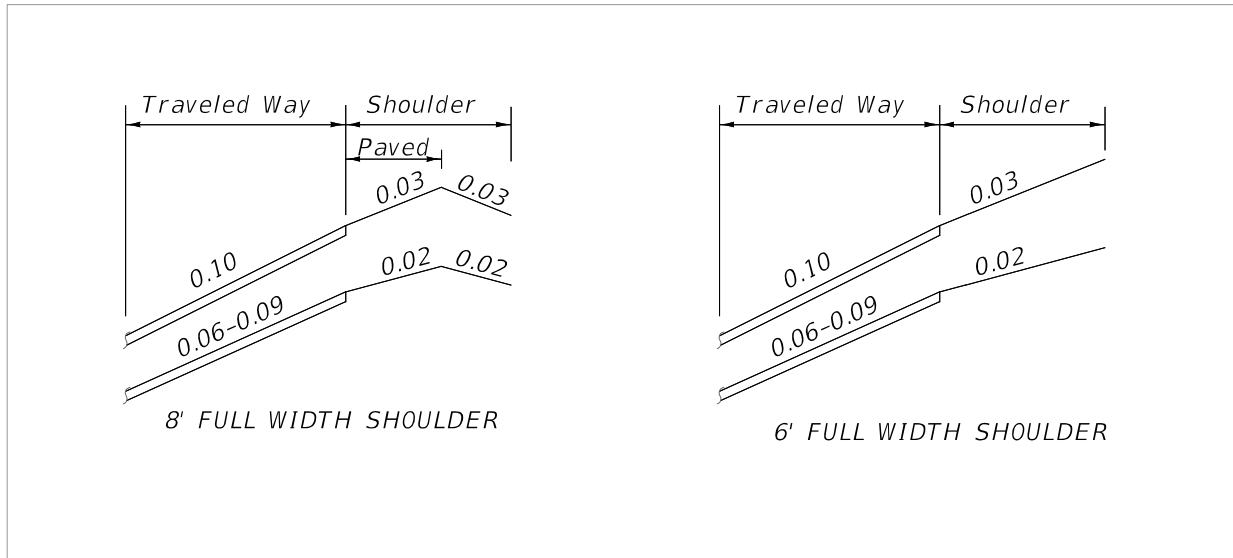
The standard cross slope is 0.06 on the outside shoulder and 0.05 on the median (or left) side for all roadway and ramp sections. **Figure 211.4.1** illustrates shoulder cross slopes in relationship to roadway cross slopes for normal and superelevated sections. For 5-foot (or less) paved shoulders, see **Figure 211.4.2**. When the inside travel lane is sloping toward the median, the inside shoulder cross slope may be increased to 0.06.

For projects constructed with concrete pavement, the first one foot of the outside shoulder is cast with the outside travel lane and will have the same cross slope (and superelevation) as the outside lane. Superelevation of the shoulder pavement is to be rotated about the outside edge of the outside slab.

**Figure 211.4.1 Shoulder Superelevation**



**Figure 211.4.2 Special Ramp Shoulder Superelevation**

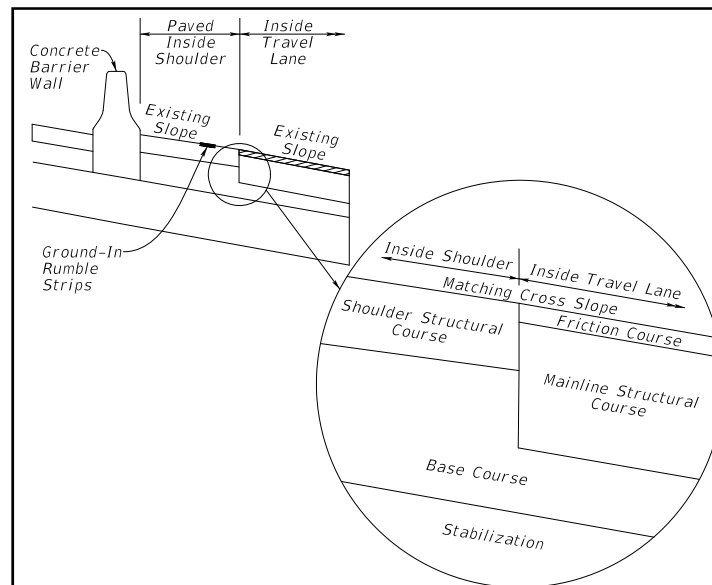


### 211.4.3 Limits of Friction Course on Paved Shoulders

Extend the friction course 8 inches onto both the median and outside paved shoulders of roadways.

For locations where median barrier wall is continuous and shoulder slopes toward the travel lane, consider constructing the inside shoulder pavement flush with the friction course placed on the adjacent travel lane. This will address any concerns for trapping water on the shoulder as demonstrated in **Figure 211.4.3**.

**Figure 211.4.3 Flush Shoulder Pavement**



## 211.4.4 Audible and Vibratory Treatment

Audible and vibratory treatments provide a lane departure warning. Include either ground-in rumble strips or profiled thermoplastic audible and vibratory treatment on LA Facilities.

### 211.4.4.1 Ground-in Rumble Strips

Use ground-in rumble strips on mainline flexible pavement shoulders in accordance with [Standard Plans](#), [Index 546-010](#). Use the skip array on both inside and outside shoulders. Use the continuous array in advance of bridge ends for a distance of 1,000 feet or back to the gore recovery area for mainline interchange bridges. **Figure 211.4.4** provides guidance for placement of ground-in rumble strips.

Exclude ground-in rumble strips at the following locations:

- (1) On bridges, terminate at the approach slab joint.
- (2) On approach to mainline toll plazas, terminate at the end of the mainline normal section.

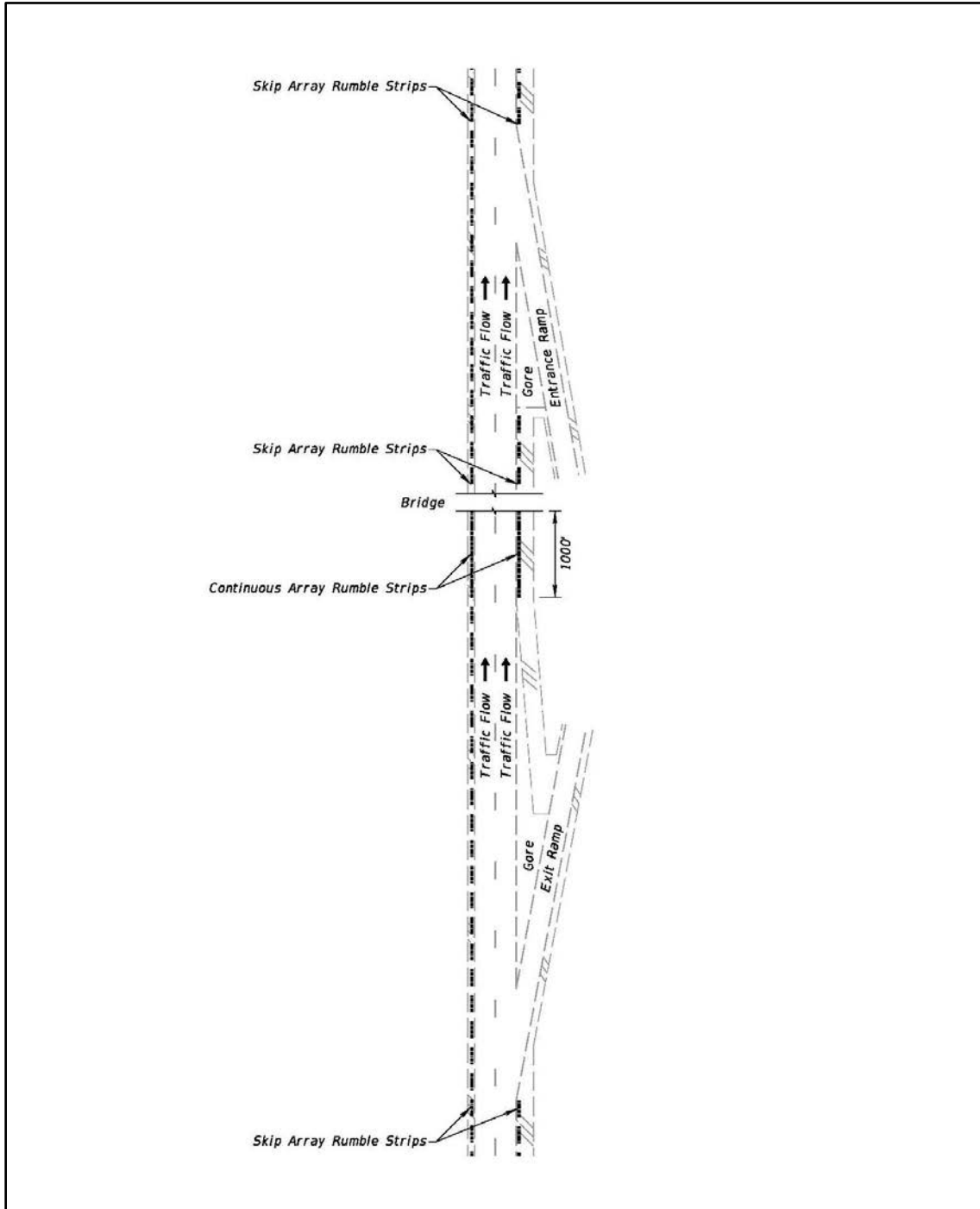


- (3) On All Electronic Tolling (AET) facilities within the tolling area as defined in Appendix 17 of the **General Tolling Requirements** ([GTR](#)).
- (4) On outside shoulders of entrance ramp terminals, terminate at the point of the physical gore and resume at the end of the acceleration lane taper.
- (5) On outside shoulders of exit ramp terminals, terminate at the start of the deceleration lane taper, and resume at the point of the physical gore.
- (6) On either side of median crossover openings, terminate within 400 feet.

#### **211.4.4.2 Profiled Thermoplastic**

Use profiled thermoplastic for inside and outside edge line pavement markings on roadways with rigid pavement shoulders.

**Figure 211.4.4 Placement of Ground-in Rumble Strips**



### 211.4.5 Emergency Refuge Areas

Consider including Emergency Refuge Areas (ERAs) in areas where additional shoulder widths are deemed necessary (e.g., law enforcement, vehicle refuge). Coordinate with Traffic Operations, Maintenance, and Law Enforcement to determine if ERAs would be appropriate for the roadway facility.

For express lanes projects, consider ERAs where deemed necessary in coordination with Traffic Engineering and Operations, Maintenance, Law Enforcement, and Toll Operations. For express lanes in constrained conditions, a staggered shoulder may be designed to allow storage of disabled or damaged vehicles.

Modification for Non-Conventional Projects:

Delete **FDM 211.4.5** and see RFP for requirements.

### 211.4.6 Emergency Shoulder Use (ESU)

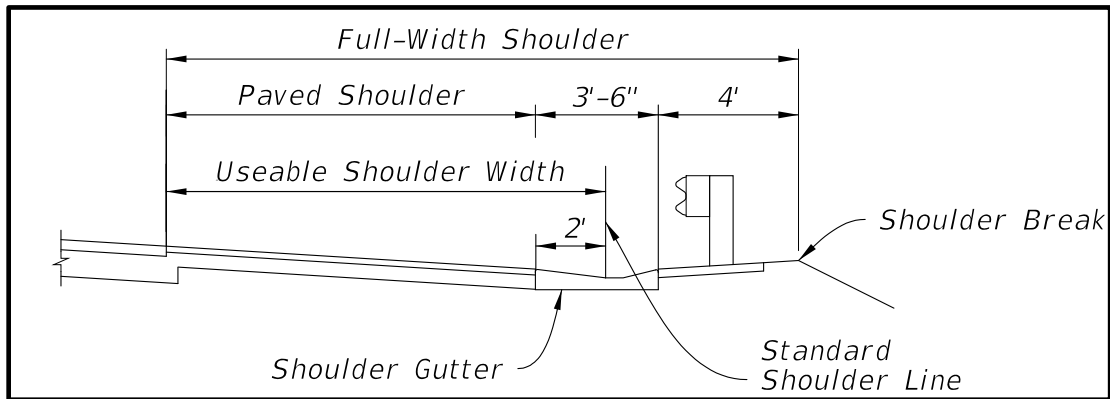
Emergency Shoulder Use (ESU) increases traffic capacity for hurricane evacuations by using existing paved shoulders as temporary travel lanes. ESU is typically implemented on evacuation routes as follows:

- On median shoulder when median paved shoulder width is at least 10 feet, or
- On outside shoulder when median paved shoulder width is less than 10 feet.

ESU evacuation routes are listed at: <http://www.fdot.gov/emergencymanagement/esu/>

Provide a minimum of 10-foot paved shoulder that is useable for travel on ESU routes identified on the Department's Emergency Management website. A portion of the shoulder gutter (when present) may be included in the useable 10-foot width; see **Figure 211.4.5**.

**Figure 211.4.5 Useable Shoulder Width with Shoulder Gutter**



On resurfacing projects where paved or usable shoulder widths are less than 10 feet, do one of the following:

- Provide shoulder modifications to allow for acceptable ESU usage, or
- Identify a future project that will provide the required shoulder modifications.

Locate median barrier in accordance with **FDM 215**. When possible, do not locate median barrier adjacent to the shoulder identified for ESU evacuation.

See **FDM 240.1.1** for ESU requirements during construction.

## 211.4.7 Use of Curb

Type F Curb may be used in areas with design speeds 45 mph or less. Type E Curb may be used in areas with design speeds 55 mph or less. This applies to both median and outside shoulder locations. All curb is prohibited in areas with design speeds greater than 55 mph.

### 211.4.7.1 Existing Curb

There are infrequent sections of curbed roadways in combination with guardrail on LA Facilities. When there is no crash history associated with these applications, the curb may remain when approved by the District Design Engineer (DDE). Approval by DDE is documented through the development of the Typical Section Package.

## 211.5 Roadside Slopes

Side slopes within the clear zone are typically 1:6 or flatter. When site conditions require the use of steeper slopes, refer to new construction criteria included in **FDM 215**.

Modification for Non-Conventional Projects:

Delete **FDM 211.5** and see RFP for requirements.

## 211.6 Border Width

For new construction the required border width is 94-feet, which is measured from the outside edge of traveled way to the R/W line. This width may be reduced in the area of a crossroad terminal, as long as the design meets the requirements for clear zone, lateral offsets, drainage, and maintenance access.

Fencing, or in special cases, walls or barriers are to contain LA Facilities. These treatments are to be continuous and appropriate for each location. Treatment height and type may vary under special conditions. The treatment is typically placed at or near the LA R/W line, but location may be adjusted based on site-specific conditions (e.g., ponds, trees, bridges). Placement information and additional data is provided in [Standard Plans](#), [Indexes 550-001](#), [550-002](#), and [550-004](#).

Modification for Non-Conventional Projects:

Delete third sentence in above paragraph and see RFP for requirements.

### 211.6.1 Border Width on Reconstruction & Resurfacing Projects

For reconstruction and resurfacing projects where additional R/W will not be acquired, a Design Variation is not required when the following minimum border width is met:

- (1) The border width accommodates:
  - (a) Roadside design components such as signing, drainage features, guardrail, fencing and clear zone
  - (b) The construction and maintenance of the facility
  - (c) Permitted public utilities

- (2) Along ramps and mainline lanes where roadside barriers are used and thus clear zone is not applicable, the minimum border width from the back of a barrier or retaining wall must be 10 feet if maintenance vehicles have sufficient access from public R/W that is contiguous and unimpeded to the facility.
- (3) If the maintenance access is not continuous along a barrier or wall, and thus maintenance vehicles and equipment would need to turn around, then a sufficient turnaround area must be provided that is acceptable and approved by Maintenance.
- (4) Maintenance accessibility includes the ability for equipment and vehicles to maneuver around obstacles including fences, lights, signs, side slopes and ponds.

## 211.7 Horizontal Alignment

The centerline (CL) or baseline (BL) of construction defines the horizontal alignment for roadway and bridge construction. The CL or BL construction is a series of tangents connected by horizontal curves established by the Engineer of Record (EOR). CL or BL construction is often the same alignment as the BL of survey.

Horizontal alignment should be consistent with the expected posted speed and with environmental, physical, and economic constraints. Design speed is the principal factor controlling horizontal alignment.

Avoid placing horizontal curves, points of intersection (PI) and superelevation transitions within the limits of a structure or approach slabs. Placement of stationing equations within the limits of a structure should be avoided on contract plans. Such equations unnecessarily increase the probability of error in both the design and construction phase.

### 211.7.1 Deflections in Alignment

The point where tangents intersect is known as the point of intersection (PI). Avoid the use of a PI with no horizontal curve; however, there may be conditions where it is necessary. The maximum deflection along the mainline and ramps without a horizontal curve are as follows:

- Design speed  $\leq$  40 mph is 2°00'00".
- Design speed  $\geq$  45 mph is 0°45'00".

## 211.7.2 Horizontal Curves

A horizontal curve should not be introduced near the crest of a vertical curve. The combination of horizontal and vertical curves can greatly reduce sight distance; i.e., hide the horizontal curve from the approaching driver. The hazard can be avoided by having the horizontal curvature lead the vertical curvature; i.e., the horizontal curve is made longer than the vertical curve.

Flatter curvature with shorter tangents is preferable to sharp curves connected by long tangents; i.e., avoid using minimum horizontal curve lengths. Avoid long tangents followed by sharp curves.

**Table 211.7.1** provides the desirable horizontal curve lengths to be used in establishing the horizontal alignment. Desirable curve lengths for interstate, freeways and expressways are based on 30-times the design speed ( $30V$ ), where  $V$  = design speed in mph. Desired curve lengths for low-speed ramps are based on 15-times the design speed ( $15V$ ), and high-speed ramps are based on  $30V$ .

**Table 211.7.1 Length of Horizontal Curve**

Length Of Horizontal Curve (ft.)										
Interstate, Freeway and Expressways based on Design Speed (mph)										
	25	30	35	40	45	50	55	60	65	70
<b>Desirable</b>	N/A	N/A	N/A	N/A	N/A	1500	1650	1800	1950	2100
<b>Minimum</b>	N/A	N/A	N/A	N/A	N/A	750	825	900	975	1050
Ramps based on Design Speed (mph)										
	25	30	35	40	45	50	55	60	65	70
<b>Desirable</b>	400	450	525	600	675	1500	1650	1800	1950	2100
<b>Minimum</b>	400	400	400	400	400	750	825	900	975	1050
<b>Notes:</b>										
(1) Provide the desirable length; however, when desired length cannot be attained, provide the greatest length possible, but not less than the minimum.										

## 211.8 Superelevation

The criteria contained in **FDM 210.9** is applicable for Interstates, Freeways, and Expressways. The RRR criteria contained in **FDM 210.9.2** applies to Limited Access resurfacing projects.

Superelevation rates of 0.10 maximum are required on high speed LA Facilities, except for the portion of a ramp that adjoins an arterial. For the portion of a ramp that adjoins to an arterial, match the superelevation rate of the arterial. The terminal and the area abutting the LA Facility is controlled by Limited Access criteria and must be designed for 0.10 maximum superelevation rate.



## 211.9 Vertical Alignment

The profile grade line defines the vertical alignment for roadway and bridge construction. The profile grade line is a series of tangents connected by vertical curves. For undivided highways the profile grade line is typically located at the horizontal centerline of the roadway. For divided highways a profile grade line should be established for each direction of travel.

Meeting vertical alignment criteria assures proper transitions, sight distances, and clearances.

LA facilities play a critical role during hurricane evacuation and re-entry in the aftermath. Designing the mainline travel lanes to be above the 100-year flood plain elevation (established by FEMA or other pertinent studies) is a requirement on Florida's Turnpike Facilities and should be considered for all LA facilities. See **FDM 210.10.3** for all other vertical clearance requirements.

Minimum vertical clearances for bridges structures is given in **FDM 260.6**.

### 211.9.1 Grades

The slope or grade of each tangent is expressed in percent rise (+) or fall (-); e.g., +2.000% or -2.000%. The maximum grades that may be used in establishing the vertical alignment is given in **Table 211.9.1**.

**Table 211.9.1 Maximum Grades**

Facility Type	Maximum Grades (percent)									
	Design Speed (mph)									
	25	30	35	40	45	50	55	60	65	70
LA Facilities	N/A	N/A	N/A	N/A	N/A	4	4	3	3	3
Ramps	7	7	6	6	5	5	4	4	3	3

**Notes:**

- (1) Roadways located in rolling terrain may be 1% greater than value shown in the table. However, LA Facilities designed to 70 mph will be restricted to 3% maximum grade.
- (2) For roadways with significant (10% or more) heavy truck traffic the maximum grade used should not exceed 4%.
- (3) For resurfacing projects, when existing grades do not meet the above requirements but meet the standards in effect at the time of construction, the existing grade may remain.
- (4) One-way descending grades on ramps may be 2% greater than values show, in special cases.

The point where tangents intersect is known as the vertical point of intersection (VPI). When two tangent grades intersect and no vertical curve is provided, the “kink” is known as the point of intersect (PI). The maximum change in grade (i.e., algebraic change) without a vertical curve is provided in **Table 210.10.2**.

### 211.9.2 Vertical Curves

A vertical curve must be provided when the change in grade of two intersecting tangent grades exceed the values shown in **Table 210.10.2**. A vertical curve is identified by a curve length (L) which is equal to the product of the K value (K) and the algebraic difference in grades (A).

**Tables 211.9.2** and **211.9.3** contain vertical alignment criteria for Interstates, Freeways, Expressways, and ramps.

**Table 211.9.2 K Values for Vertical Curves**

Type of Curve	Minimum K Values for Vertical Curves									
	Design Speed (mph)									
	25	30	35	40	45	50	55	60	65	70
<b>Interstate</b>										
<b>Sag</b>	N/A					115	136	157	181	206
<b>Crest (New Construction)</b>	N/A					185	245	313	401	506
<b>Crest (Resurfacing)</b>	N/A					114	151	193	247	312
<b>Freeway and Expressways</b>										
<b>Sag</b>	N/A					96	115	136	157	181
<b>Crest (New Construction)</b>	N/A					136	185	245	313	401
<b>Crest (Resurfacing)</b>	N/A					84	114	151	193	247
<b>Ramps</b>										
<b>Sag</b>	26	37	49	64	79	96	115	136	157	181
<b>Crest (New Construction)</b>	19	31	47	70	98	136	185	245	313	401
<b>Crest (Resurfacing)</b>	12	19	29	44	61	84	114	151	193	247
<p><b>Notes:</b>                      Length, <math>L = KA</math>                      Where: <math>K</math> = Rate of vertical curvature (a.k.a., <math>K</math> value)  <math>L</math> = Length of vertical curve, (feet)  <math>A</math> = Algebraic difference in grades, (percent)</p> <p>(1) New construction <math>K</math> values are based on an eye height of 3.5 feet and an object height of 6 inches. Resurfacing <math>K</math> values are based on an eye height of 3.5 feet and an object height of 2 feet.</p> <p>(2) The minimum curve length must not be less than values shown in <b>Table 211.9.3</b>.</p> <p>(3) Vertical curves within a system interchange are to use <math>K</math> values based on the higher system.</p> <p>(4) Use interstate, freeway, or expressway <math>K</math> values on vertical curves located within the ramp terminal area. Ramp vertical curve <math>K</math> values are used for ramps outside of the ramp terminal area.</p>										

**Table 211.9.3 Minimum Vertical Curve Length**

Type of Curve	Curve Length (ft.)									
	Design Speed (mph)									
	25	30	35	40	45	50	55	60	65	70
<b>Interstate, Freeway and Expressways</b>										
<b>Sag</b>	N/A					800				
<b>Crest (Open Highway)</b>	N/A					1,000				
<b>Crest (Within Interchanges)</b>	N/A					1,800				
<b>Ramps</b>										
<b>Sag</b>	75	90	105	120	135	200	250	300	350	400
<b>Crest</b>						300	350	400	450	500

## 211.10 Stopping Sight Distance

Stopping sight distance criteria is provided in **Tables 211.10.1** and **211.10.2**.

**Table 211.10.1 Minimum Stopping Sight Distance for Interstate**

Grade (percent)		Minimum Stopping Sight Distance (ft.)				
		Design Speed				
		50	55	60	65	70
Downgrade	≤ 2	495	570	645	730	820
	3	516	595	673	767	861
	4	524	605	685	781	878
	5	534	616	698	797	896
	6	544	628	713	813	915
	7	554	640	727	831	935
	8	565	654	744	850	957
	9	577	668	761	870	981
Upgrade	≤ 2	495	570	645	730	820
	3	475	544	613	697	780
	4	469	537	605	687	768
	5	463	531	597	678	758
	6	458	525	590	669	748
	7	453	518	583	661	738
	8	449	513	576	653	729
	9	445	508	570	646	721

**Table 211.10.2 Minimum Stopping Sight Distance for Freeways, Expressways, and Ramps**

Grade (percent)		Minimum Stopping Sight Distance (ft.)									
		Design Speed (mph)									
		25	30	35	40	45	50	55	60	65	70
Downgrade	≤ 2	155	200	250	305	360	425	495	570	645	730
	3	158	205	257	315	378	446	520	598	682	771
	4	160	208	261	320	385	454	530	610	696	788
	5	162	211	266	326	392	464	541	623	712	806
	6	165	215	271	333	400	474	553	638	728	825
	7	167	218	276	339	408	484	565	652	746	845
	8	170	222	281	346	417	495	579	669	765	867
	9	173	227	287	354	427	507	593	686	785	891
Upgrade	≤ 2	155	200	250	305	360	425	495	570	645	730
	3	147	190	237	289	344	405	469	538	612	690
	4	146	188	234	285	339	399	462	530	602	678
	5	144	186	231	281	335	393	456	522	593	668
	6	143	184	229	278	331	388	450	515	584	658
	7	142	182	226	275	327	383	443	508	576	648
	8	141	180	224	272	323	379	438	501	568	639
	9	139	179	222	269	320	375	433	495	561	631

The geometric design developed for LA Facilities considers locations where decision sight distance is critical such as interchanges, toll plazas, lane drops, and express lanes ingress/egress locations. Decision sight distance requirements are in **AASHTO Green Book, Section 3.2.3**. If it is not practical to provide decision sight distance at these locations, or if relocation of the critical decision points is not feasible, special attention will

be given to the use of suitable traffic control devices for providing advance warning of the sub-standard condition.

Do not place express lane ingress or egress within the limits of a Design Variation or Design Exception processed for sight distance.

## **211.11 Structures**

Refer to **FDM 260** for information on bridge structures.

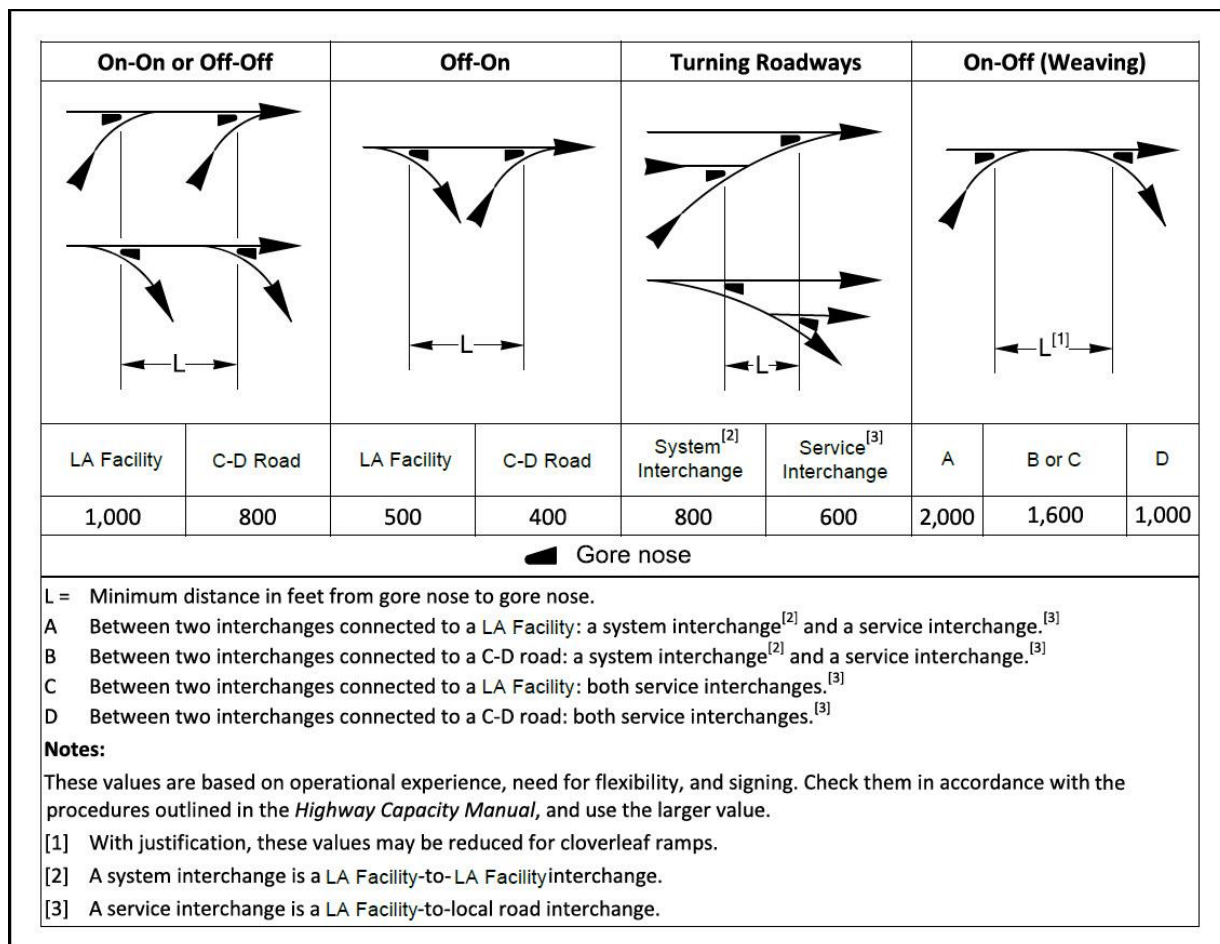
## 211.12 Interchange and Ramp Spacing

Interchange spacing is measured along the freeway or interstate centerline between the centerlines of the crossroads. Refer to **FDM 201.3** for the minimum spacing between adjacent interchanges.

In urban areas, spacing less than one mile may be used with C-D roads or grade-separated (braided) ramps.

The spacing between interchanges may also be dependent on the ramp connection spacing. The minimum connection spacing between the gore noses of adjacent ramps is provided in **Figure 211.12.1**. Additional information on interchanges is in **AASHTO Green Book, Chapter 10**.

**Figure 211.12.1 Ramp Connection Spacing**



Ref: Figure 10-68, 2011 AASHTO Green Book



## 211.12.1 Weaving Sections

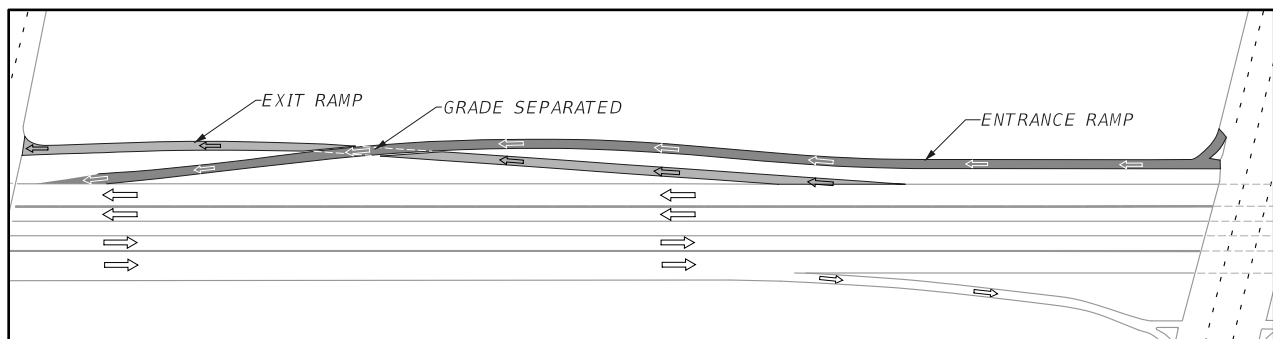
Weaving sections are defined in *2011 AASHTO Green Book, Section 2.4.6*.

When an entrance is followed by an exit, the minimum distance between gore noses is governed by weaving considerations per the procedure outlined in the *Highway Capacity Manual (HCM)*. On-off Weaving is illustrated in *Figure 211.12.1*. If the minimum weaving distance cannot be provided, replace the weaving maneuver with physical separation; e.g., grade separation or barrier. For more information regarding barriers, refer to *FDM 215*.

### 211.12.1.1 Braided Ramps

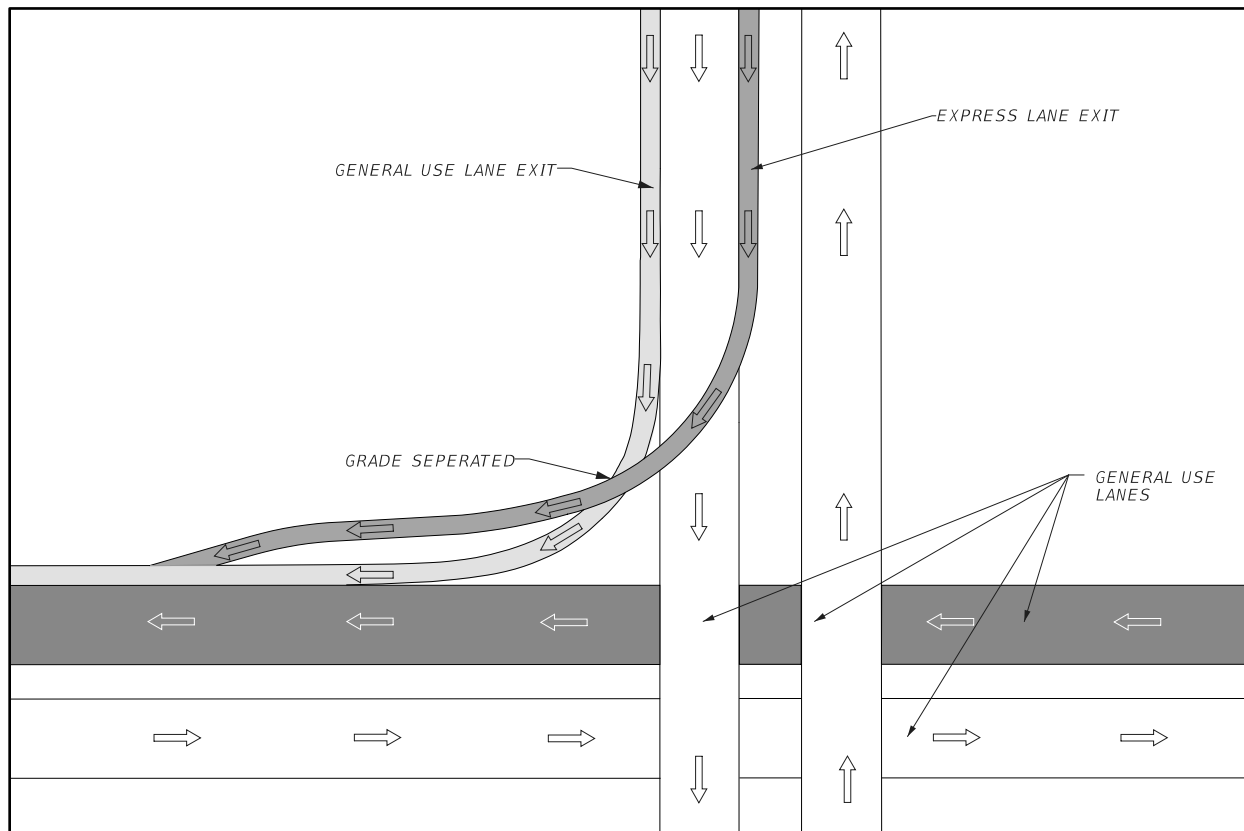
Ramps that are grade-separated and cross over one another are known as braided ramps. They are typically used to achieve the required ramp spacing by converting the on-off connection into an off-on connection. An example of braided ramps is shown in *Figure 211.12.2*. These configurations are used on a limited basis because of the large cost typically associated with them.

**Figure 211.12.2 Braided Ramp Configuration**



When combining general use lane or general toll lane exits and express lane exits in a braided ramp configuration, the express lane exit merges on the right side of the general use lanes or general toll lanes as illustrated in *Figure 211.12.3*. Operational analysis determines the actual lane configuration. Refer to *Traffic Analysis Handbook* and *Interchange Access Request User's Guide* for guidance on analysis requirements.

**Figure 211.12.3 Braided Express Lane and General Use Lane Exits**



### 211.12.2 Interchange Connections

When a series of interchanges are closely spaced, attention must be given to the uniformity of interchange patterns and to lane balance. Refer to the concepts discussed in the **2011 AASHTO Green Book, Section 10.9.5**. Auxiliary lanes may be required to conform to lane balance requirements.

Successive auxiliary lanes less than 1,500 feet apart are prohibited. Auxiliary lanes may continue through an interchange to avoid this condition.

### 211.13 Ramp Terminals

Taper type and parallel type ramp terminals can be used to enter and exit a LA Facility. Geometric configuration for the taper and parallel types are depicted in [Standard Plans Index 000-525](#).

The taper type ramp terminal is not to be used where a minimum of 50 mph design speed cannot be maintained.

The parallel type entrance terminal should be used when a bridge is located within the merging lane and when turning roadway speed is less than 60% of through roadway speed. The length of the acceleration lane is determined by **2011 AASHTO Green Book, Table 10-3**.

The parallel type exit terminal should be used when the exit is partially hidden over the crest of vertical curve and when turning roadway speed is less than 60% of the through roadway speed. The length of the deceleration lane is determined by **2011 AASHTO Green Book, Table 10-5**.

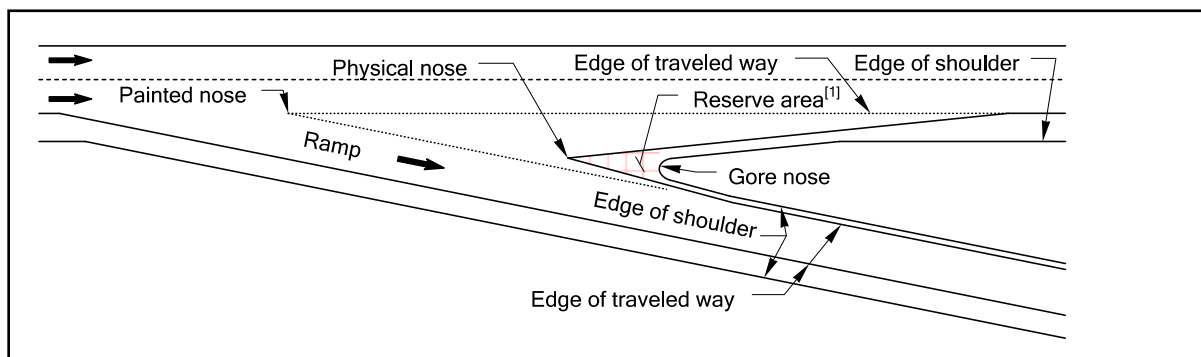
The selection of either a parallel or taper type depends on the geometrics of the highway as well as the roadway that the ramp is connecting to. In cases that have limited sight distance and close connections to a signal controlled arterial, parallel type terminals should be used to allow for sufficient deceleration.

At entrance ramps on an ascending grade, the portion of the ramp intended for acceleration and the ramp terminal should closely parallel the through roadway profile to permit entering drivers to have a clear view of the through road ahead.

Design speed of entrance and exit ramps for LA Facilities should be gradually decreased from the mainline Limited Access design speed to the design speed of the ramp. The minimum speed used to design the first curve adjacent to the Limited Access highway is 20 mph below the design speed of the highway.

**Figure 211.13.1** illustrates a basic configuration and terminology used when designing ramp terminals.

**Figure 211.13.1 Ramp Gore**



## 211.14 Express Lanes Access Points and Access Types

The design of express lanes access points is based on major origin and destination patterns, the location of toll points, and the location of existing interchanges with the general use or general toll lanes. Refer to **FELM** for considerations when identifying location of express lanes access points. The operational analysis associated with express lanes access points is performed using the methodology in the Highway Capacity Manual and/or microsimulation. Refer to [Traffic Analysis Handbook](#) and [Interchange Access Request User's Guide](#) for guidance on analysis requirements.

An access point serves one of three uses:

- (1) Point of entry to the express lanes
- (2) Intermediate point of entry/ingress or exit/egress
- (3) Termination of express lanes

When determining the point of entry and the termination of express lanes, consideration is given to future phased implementation plans for the corridor depicted in the ultimate express lanes diagram. Avoid temporary access points. Refer to **FELM**.

Avoid locating an express lanes access point in the same weaving area as other highway weaving movements; interchange on-ramps, interchange off-ramps, or auxiliary lanes. Access points are located to provide the required weave length between the express lanes and general use lanes or general toll lanes. If placed closer than the required minimum weave length, additional traffic control devices are added to prohibit vehicles from cutting across traffic to get into the express lane or get out to the interchange exit.

Traffic operational analyses must demonstrate that queuing from vehicles exiting the express lanes to the general use lanes or general toll lanes will not encroach on the express lanes.

Refer to **Section 2.42** of the [TEM](#) for guidelines on express lanes entrance/ingress and exit/egress signs and signing sequence.

### 211.14.1 Express Lanes Access Types

Refer to **FELM** for design considerations when selecting the access type. On Florida's express lanes, the following types of access are used:

- Slip Ramps
- Weave Lanes

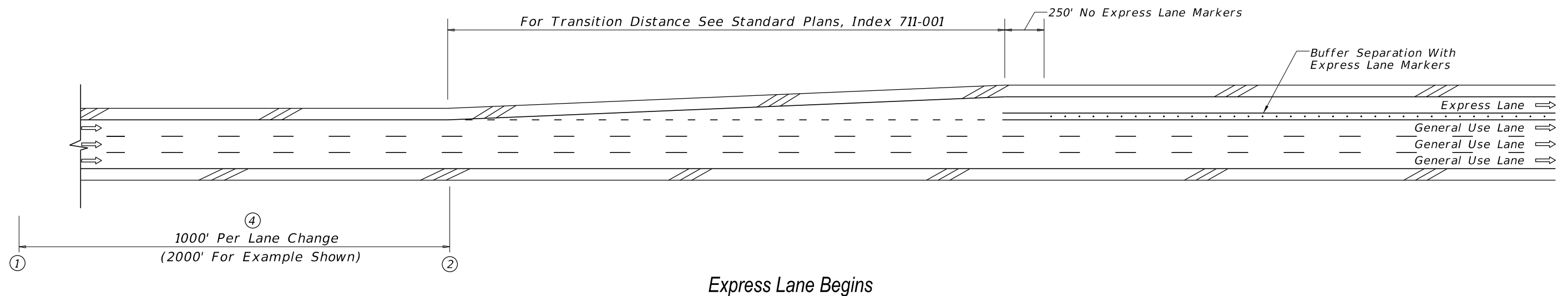
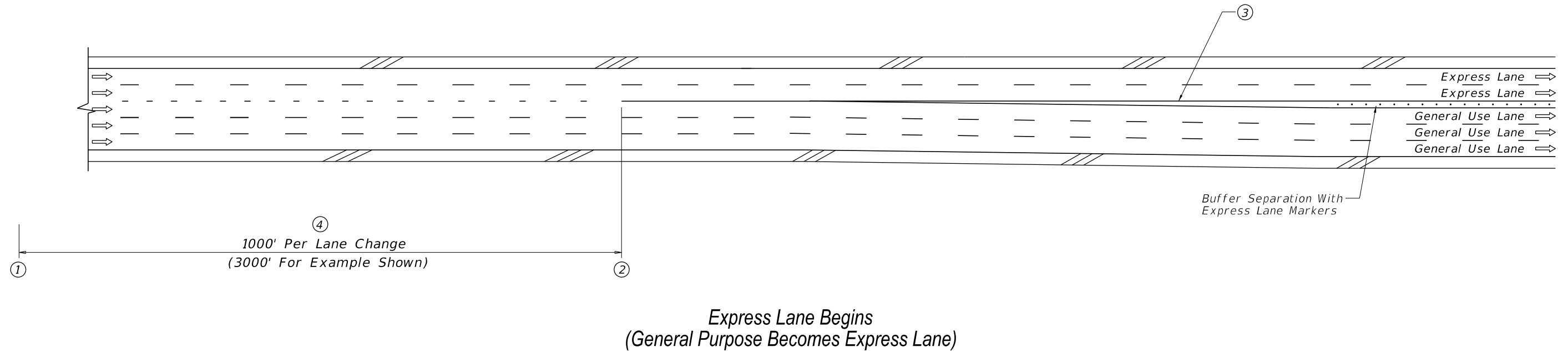
- Weave Zones
- Direct Connect

Slip ramps, weave lanes, and weave zones on the Interstate do not require an interchange access request. A weave lane or weave zone is used in constrained conditions for intermediate ingress and egress points and requires approval of the District Design Engineer.

Direct connect ramps (Express Exits) are used for system-to-system connection between express lanes facilities, toll facilities, major arterials, park-and-ride facilities, and transit facilities. Express Exits on the Interstate require an interchange access request.

Standard geometric details are shown in **Exhibits 211-3** through **211-8**. The associated signing and pavement marking requirements at ingress and egress locations are shown in **Exhibits 211-9** through **211-12**.

**BEGIN EXPRESS LANES TYPICAL INGRESS FOR  
EXPRESS LANES WITH BUFFER SEPERATION**



**NOTES:**

- ① Begin weave distance
- ② End weave distance
- ③ Per FDM 210.8.1 maximum deflections without horizontal curves, 0° 45' or 76.39:1 (use 80:1)
- ④ This weave zone to allow traffic in outside general use lane to get into outside express lane

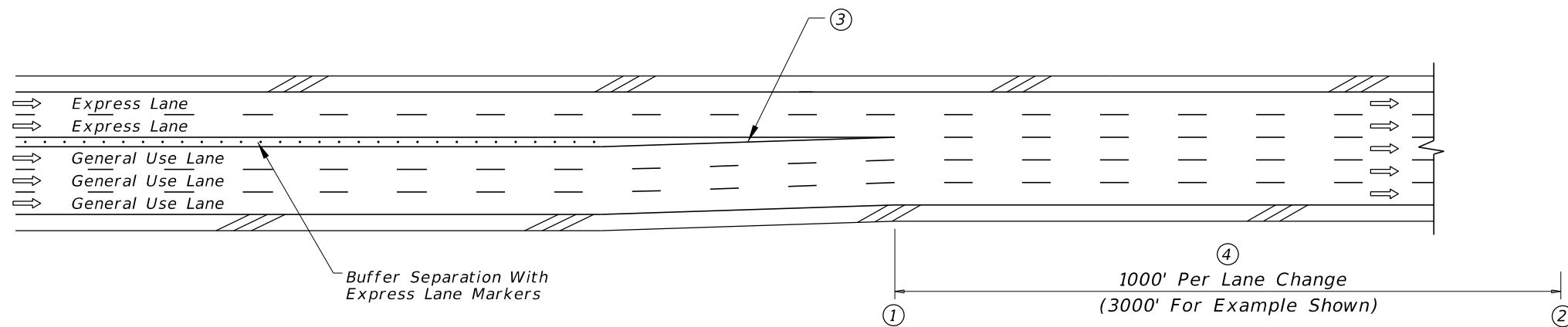
**NOTE:**

The dimensions shown in this Exhibit are typical values, and may need to be increased based upon site-specific operational analysis.

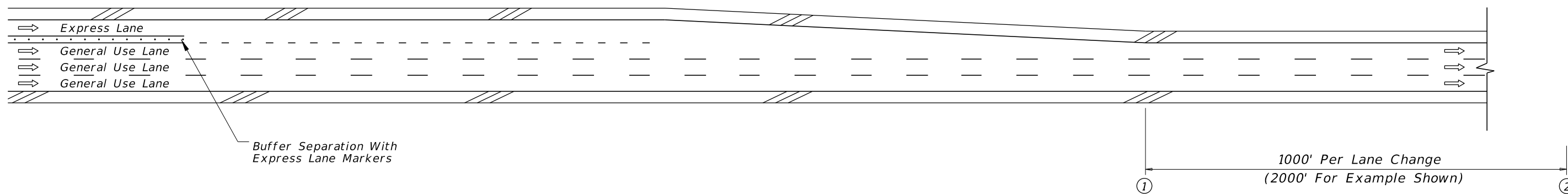
**NOT TO SCALE**

**EXHIBIT 211-3  
01/01/2019**

# END EXPRESS LANES TYPICAL EGRESS FOR EXPRESS LANES WITH BUFFER SEPERATION



Express Lanes Become General Purpose Lanes



Express Lane Ends

**NOTES:**

- ① Begin weave distance
- ② End weave distance
- ③ Per FDM 210.8.1 maximum deflections without horizontal curves, 0° 45' or 76.39:1 (use 80:1)
- ④ This weave zone to allow traffic in outside express lane to get into outside general use lane

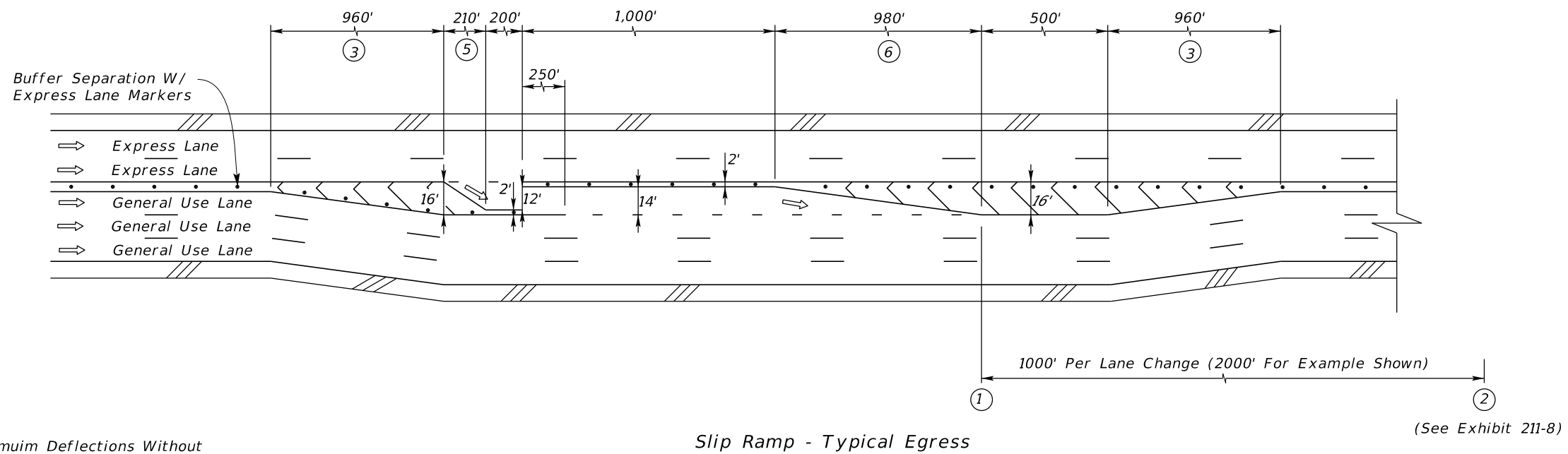
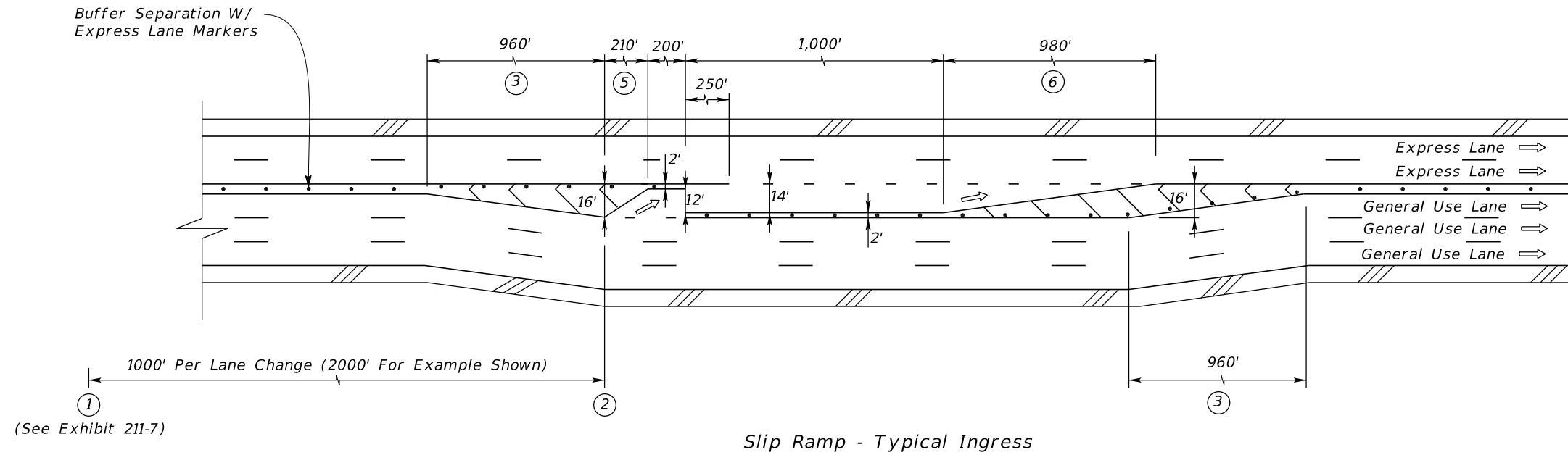
**NOTE:**

The dimensions shown in this Exhibit are typical values, and may need to be increased based upon site-specific operational analysis.

**NOT TO SCALE**

**EXHIBIT 211-4**  
01/01/2019

## SLIP RAMP TYPICAL INGRESS & EGRESS FOR EXPRESS LANES WITH BUFFER SEPARATION



**Notes:**

- ① Begin weave distance.
- ② End weave distance.
- ③ Per FDM 210.8.1, Maximum Deflections Without Horizontal Curves, 0° 45' or 76.39:1. (Use 80:1).
- ⑤ 15:1 taper.
- ⑥ Taper length based on  $L=WS$ . 70:1 taper as shown assumes 70 MPH design speed.  
Where:  
W = Width Of Lateral Transition  
In Feet  
S = Design Speed

**NOTE:**

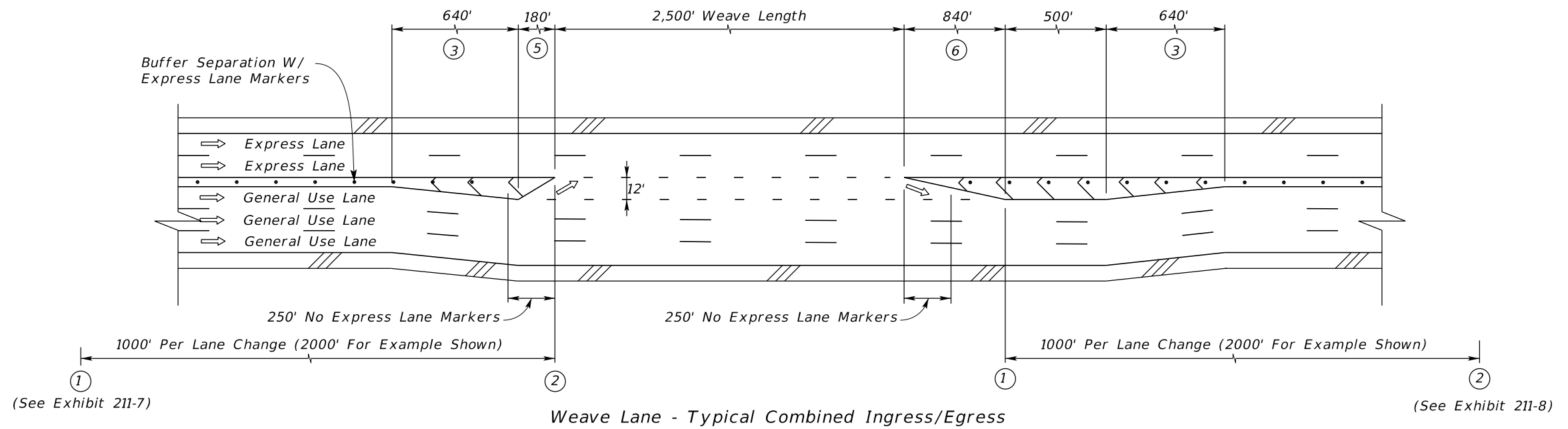
The dimensions shown in this Exhibit are typical values, and may need to be increased based upon site-specific operational analysis.

**NOT TO SCALE**

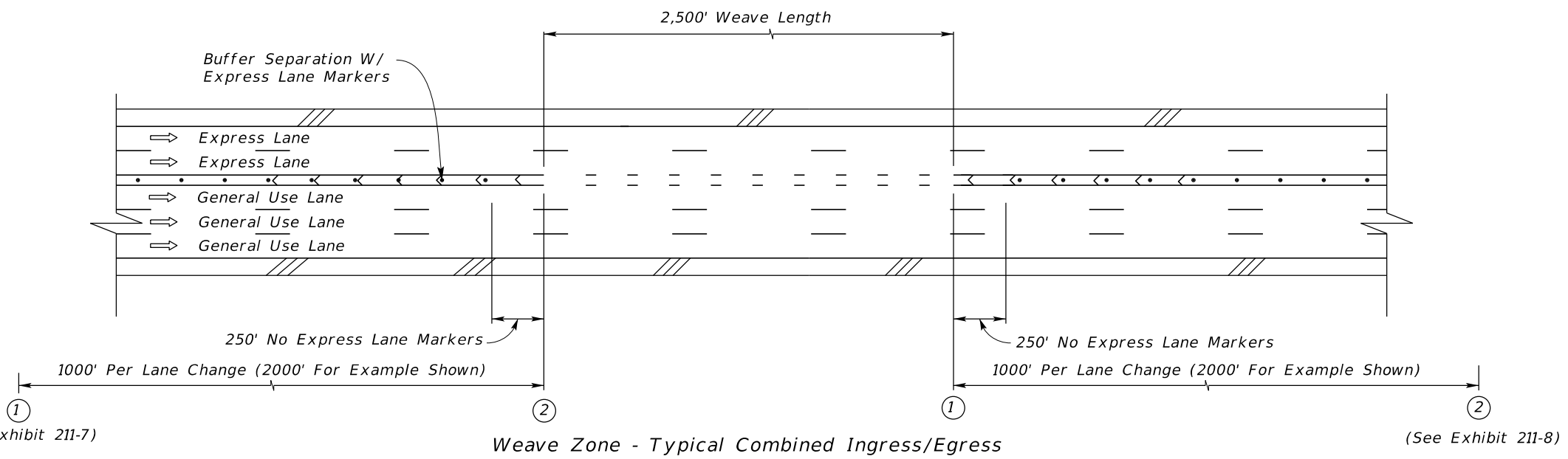
**EXHIBIT 211-5**  
01/01/2019



## WEAVE SECTIONS TYPICAL INGRESS & EGRESS FOR EXPRESS LANES WITH BUFFER SEPARATION



Weave Lane - Typical Combined Ingress/Egress



Weave Zone - Typical Combined Ingress/Egress

**Notes:**

- ① Begin weave distance. (See Exhibit 211-7)
- ② End weave distance.
- ③ Per FDOT PPM, Table 2.8.1a, Maximum Deflections Without Horizontal Curves, 0° 45' or 76.39:1. (Use 80:1).
- ⑤ 15:1 taper.
- ⑥ Taper length based on  $L=WS$ . 70:1 taper as shown assumes 70 MPH design speed.  
Where:  
W = Width Of Lateral Transition  
In Feet  
S = Design Speed

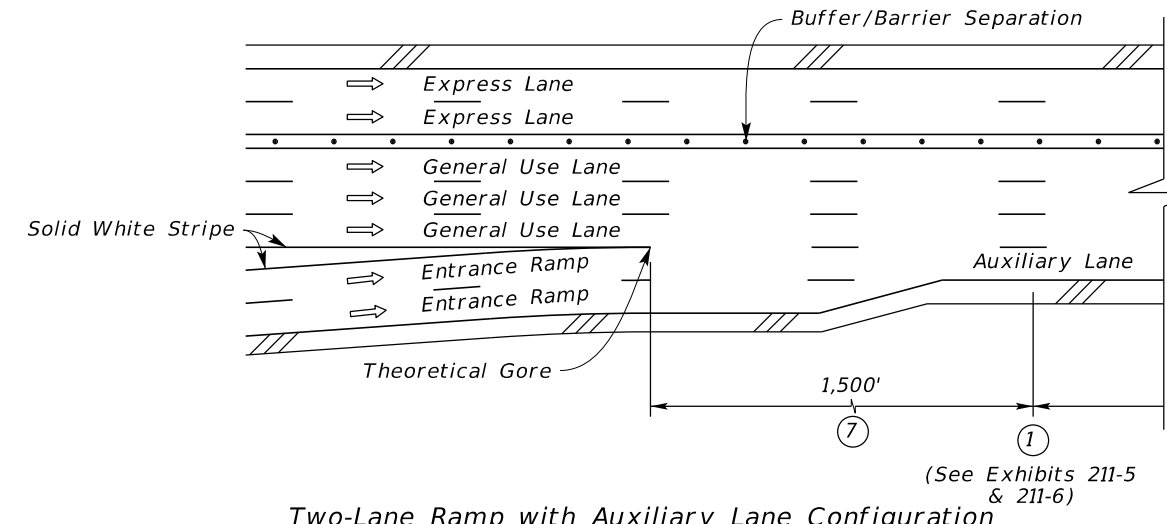
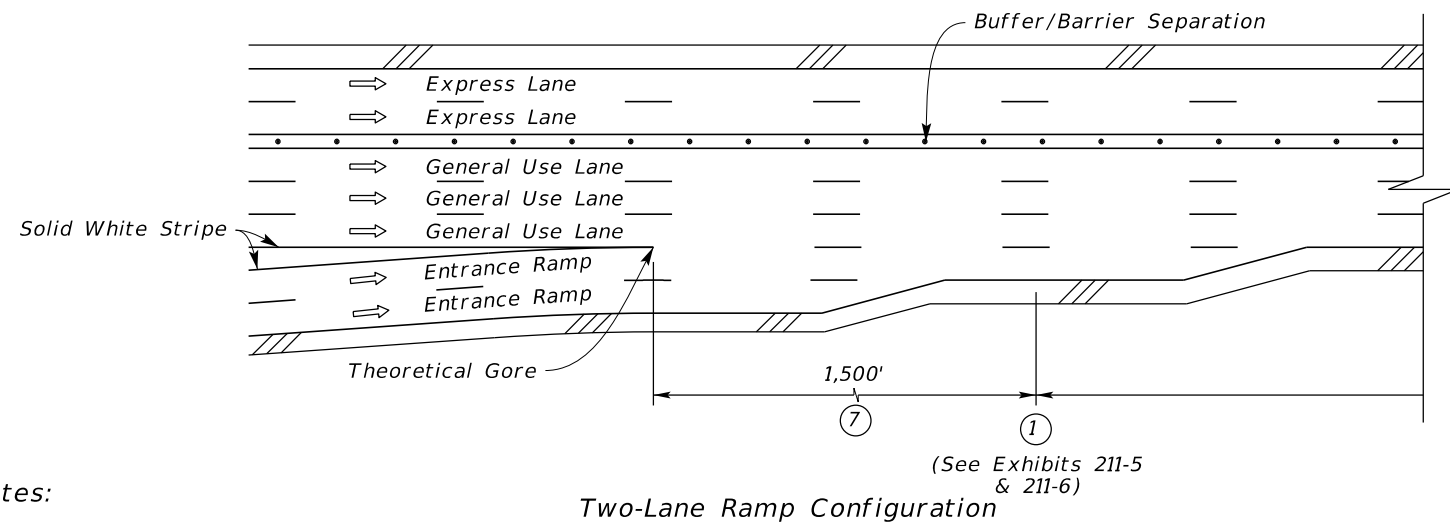
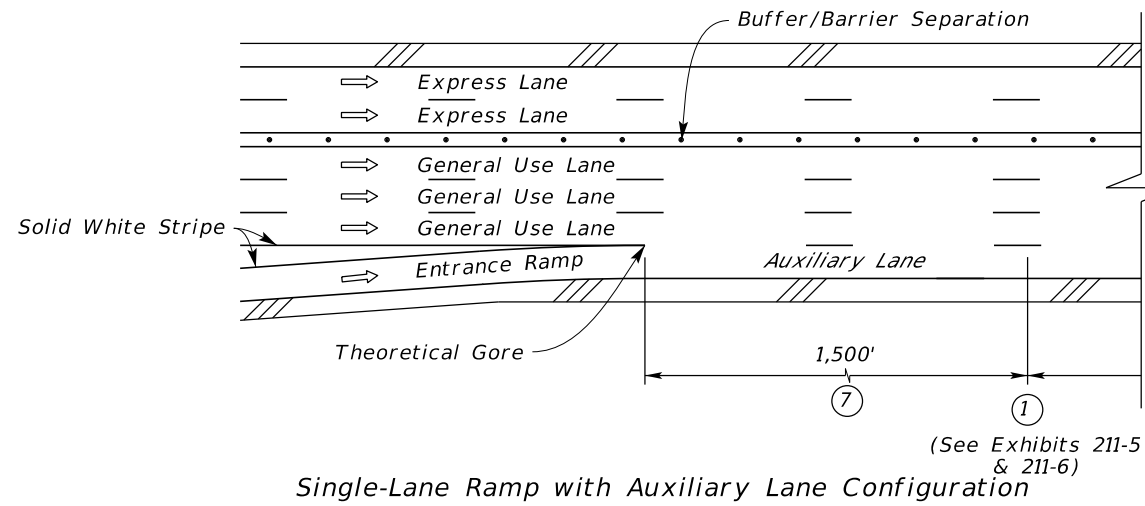
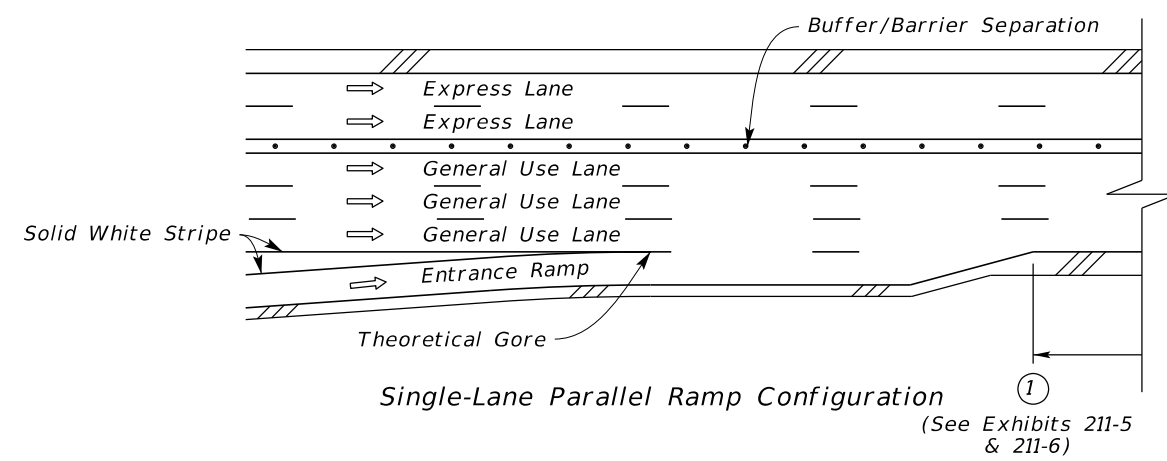
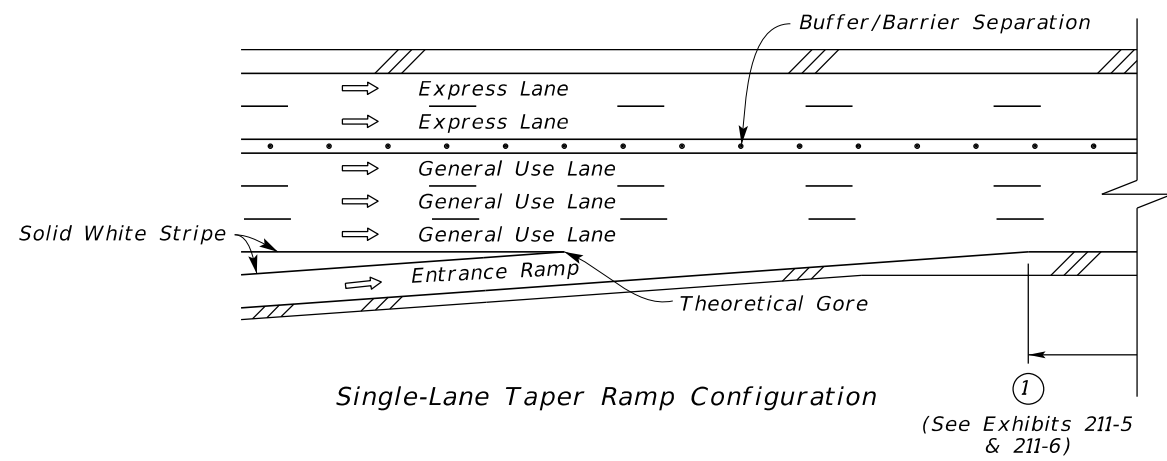
**NOTE:**

The dimensions shown in this Exhibit are typical values, and may need to be increased based upon site-specific operational analysis.

**NOT TO SCALE**

**EXHIBIT 211-6**  
01/01/2019

# EXPRESS LANES ENTRANCE TERMINAL CONFIGURATIONS



**Notes:**

- ① Begin weave distance.
- ⑦ 1,500' intended to allow ramp traffic to merge into the outside general use lane.

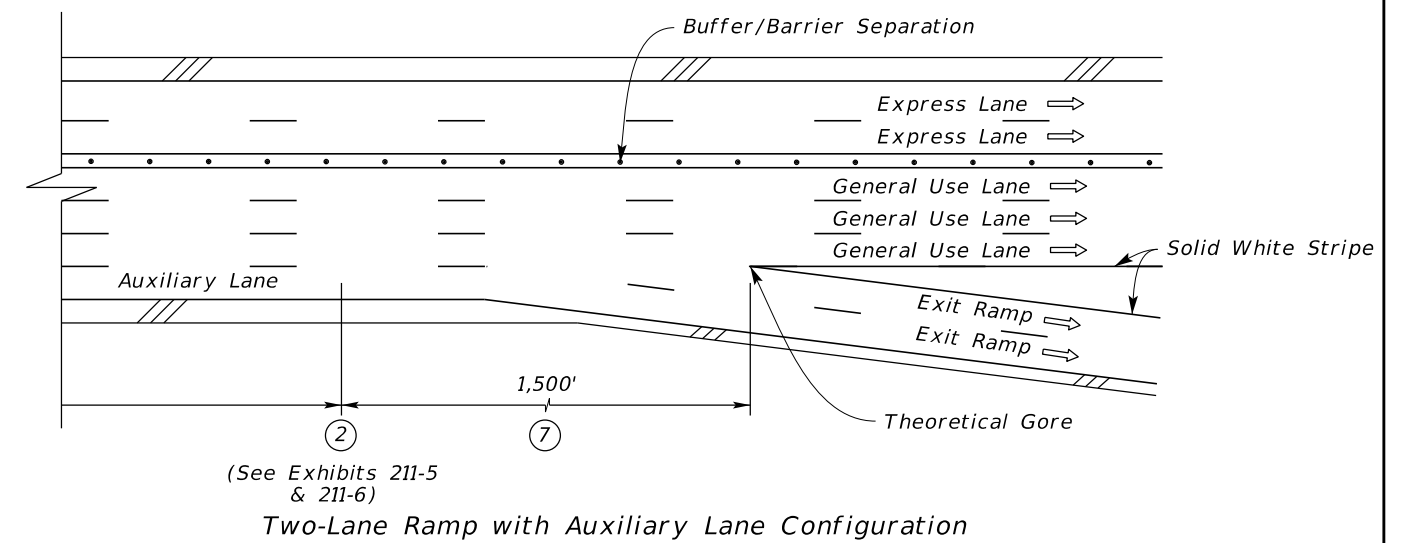
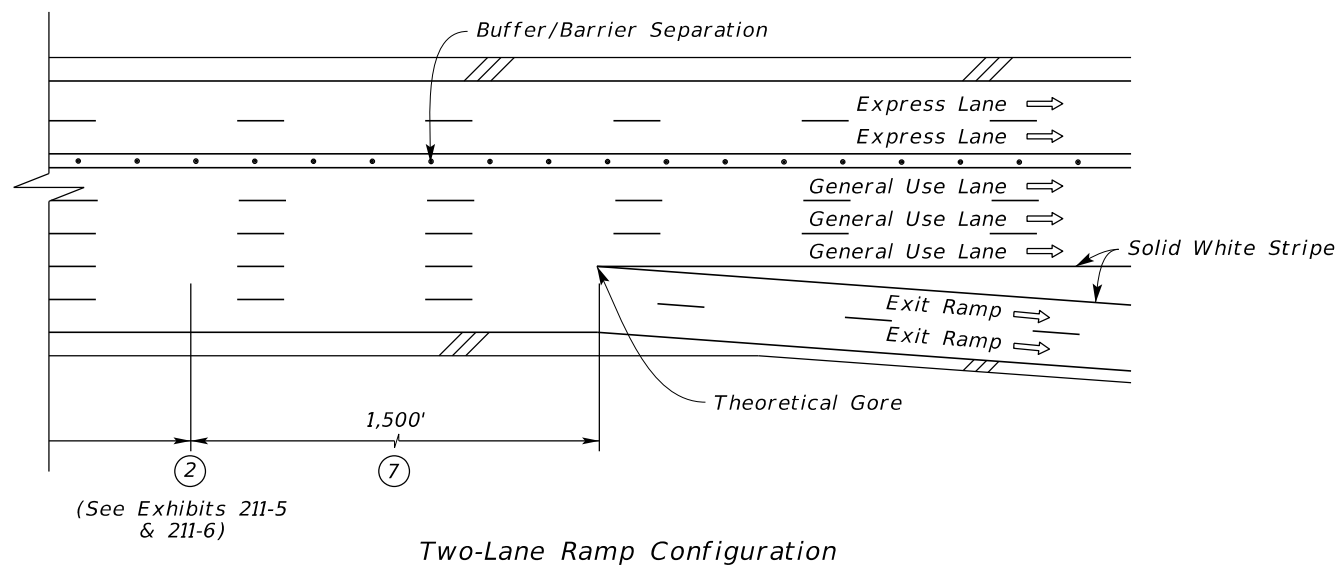
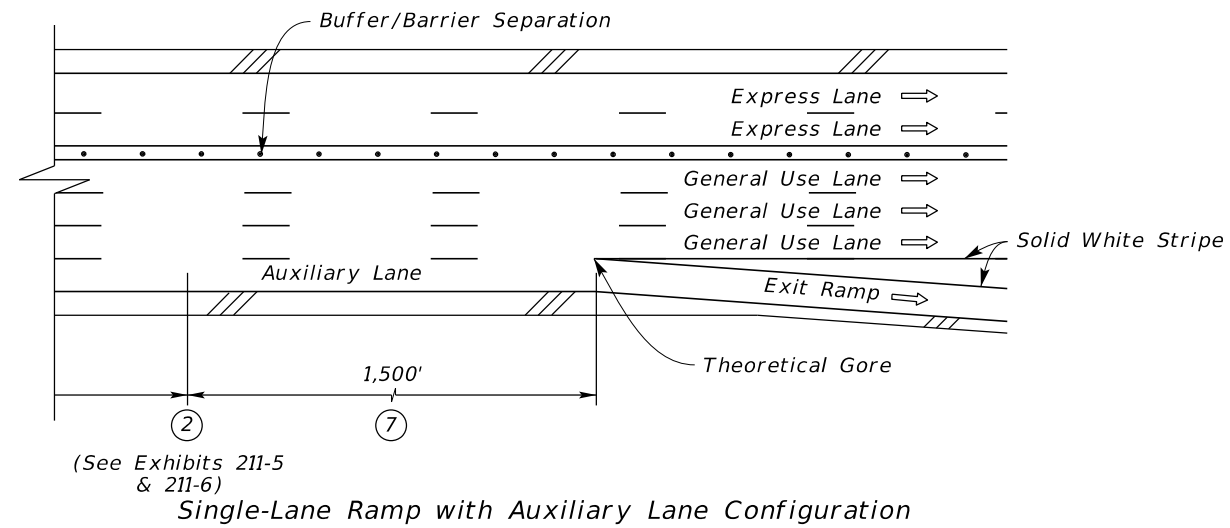
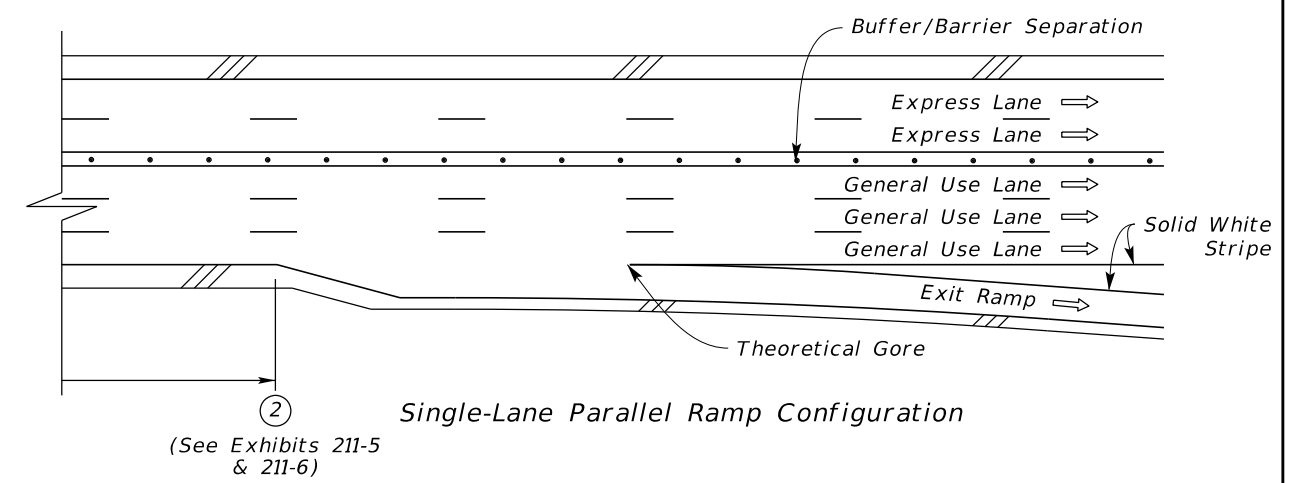
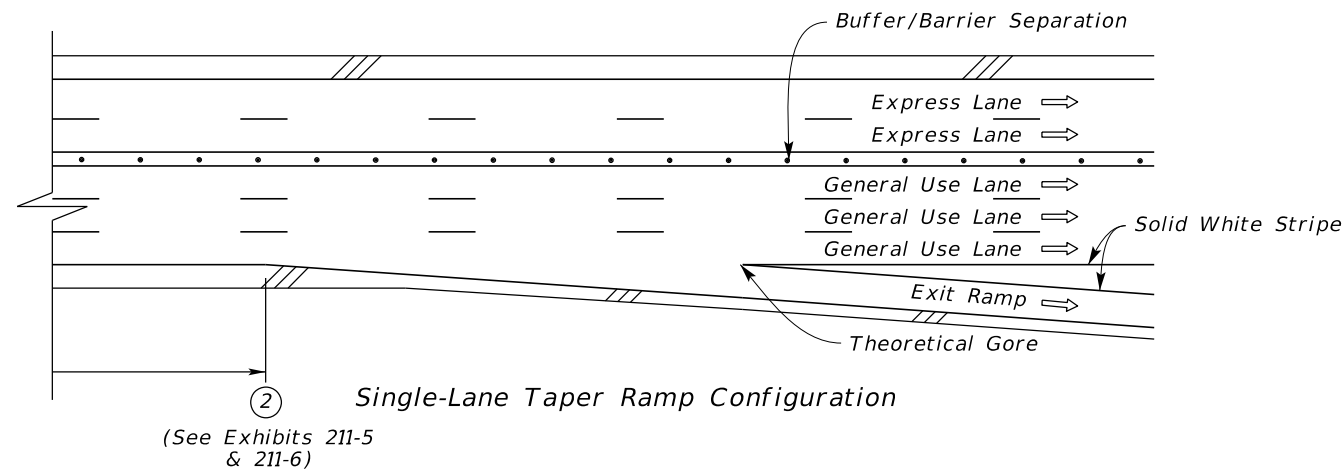
**NOTE:**

The dimensions shown in this Exhibit are typical values, and may need to be increased based upon site-specific operational analysis.

**NOT TO SCALE**

**EXHIBIT 211-7**  
01/01/2019

# EXPRESS LANES EXIT TERMINAL CONFIGURATIONS



**Notes:**

- ② End weave distance.
- ⑦ 1,500' intended to allow traffic in the outside general use lane to access the exit ramp.

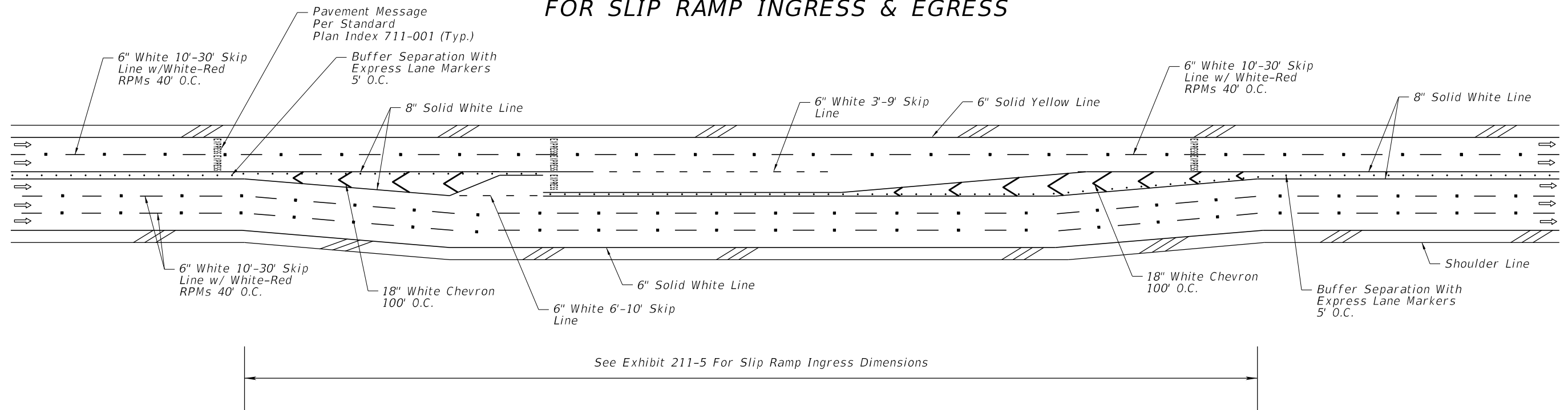
**NOTE:**

The dimensions shown in this Exhibit are typical values, and may need to be increased based upon site-specific operational analysis.

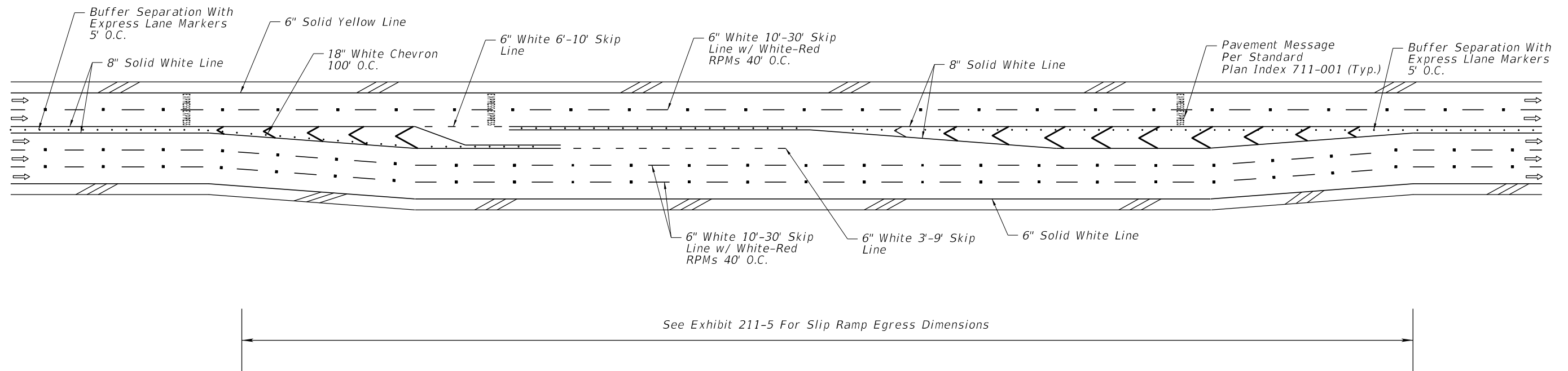
**NOT TO SCALE**

**EXHIBIT 211-8  
01/01/2019**

# EXPRESS LANES TYPICAL PAVEMENT MARKINGS FOR SLIP RAMP INGRESS & EGRESS



RPMs- RAISED PAVEMENT MARKERS  
O.C. - ON CENTER

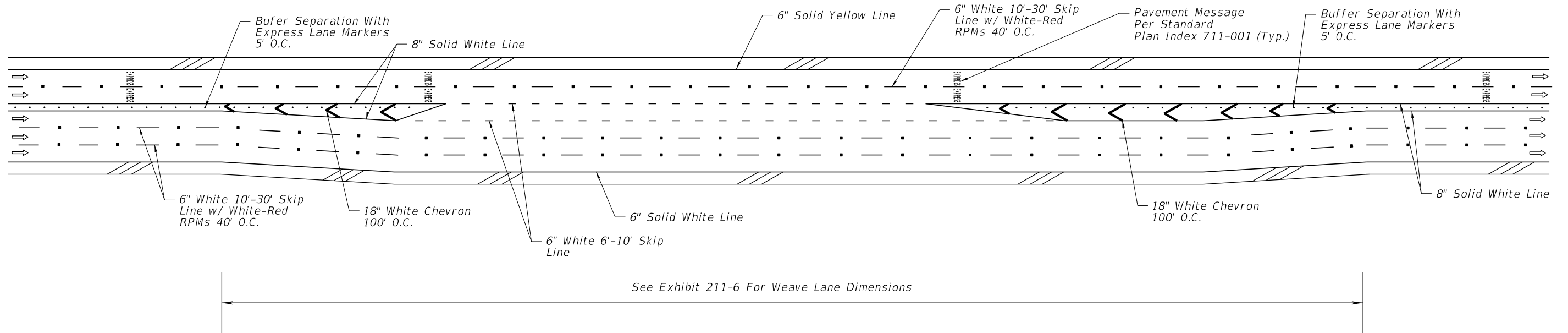


RPMs- Raised Pavement Markers  
O.C.- On Center

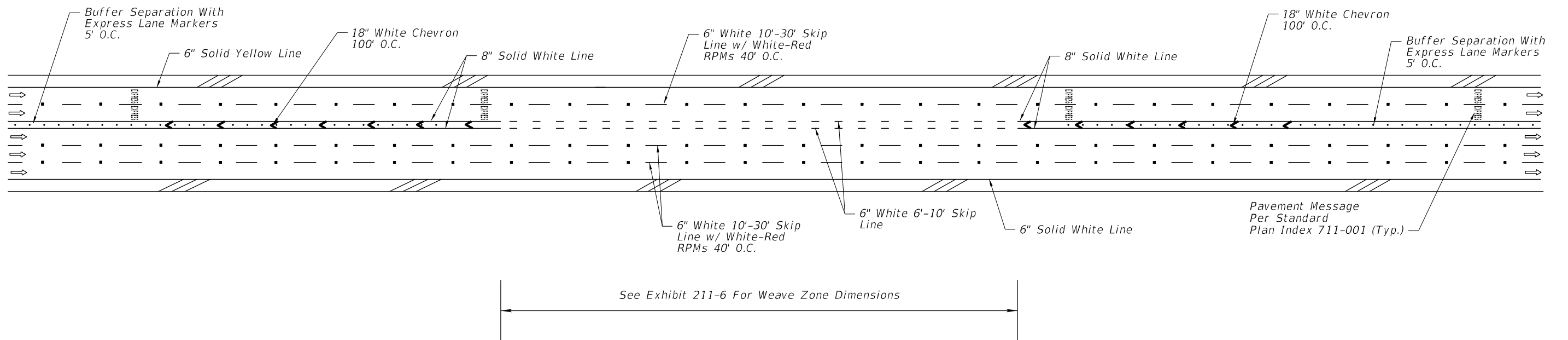
NOT TO SCALE

EXHIBIT 211-9  
01/01/2019

# EXPRESS LANES TYPICAL PAVEMENT MARKINGS FOR WEAVE SECTIONS INGRESS & EGRESS



RPMs- Raised Pavement Markers  
O.C.- On Center

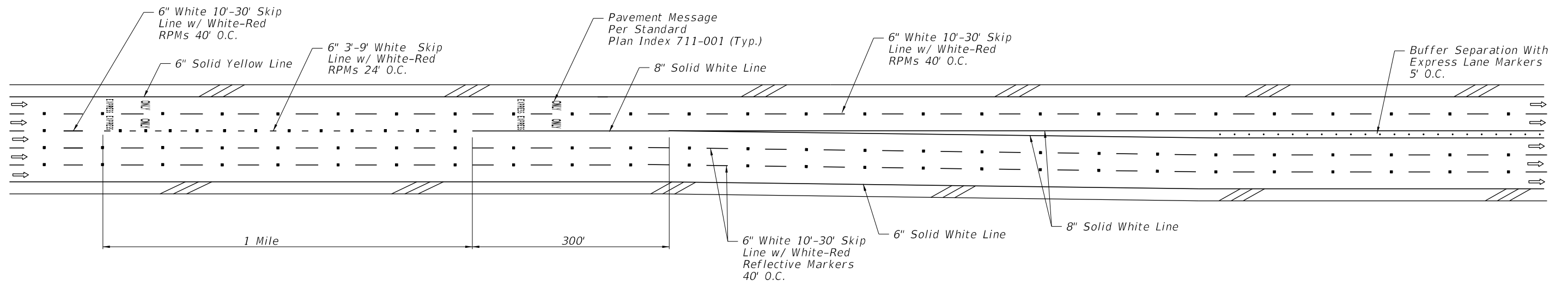


RPMs- Raised Pavement Markers  
O.C.- On Center

NOT TO SCALE

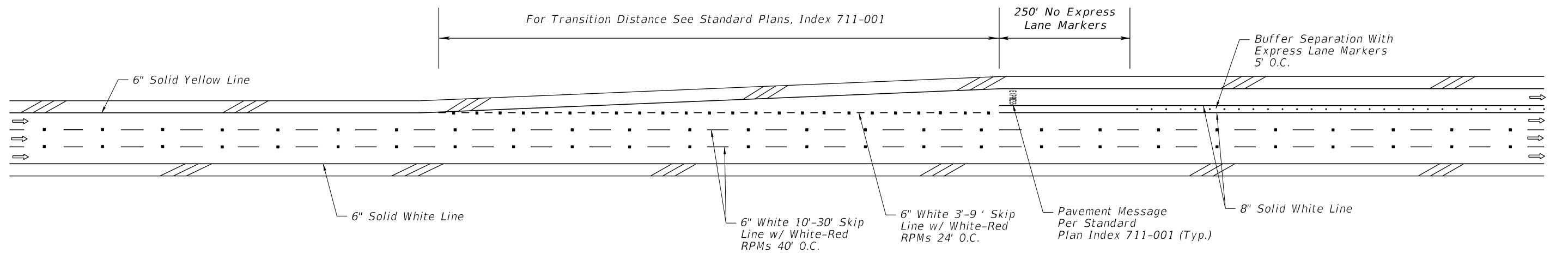
EXHIBIT 211-10  
01/01/2019

# EXPRESS LANES TYPICAL PAVEMENT MARKINGS FOR BEGIN EXPRESS LANES



**Express Lane Begins**  
(General Purpose Becomes Express Lane)

RPMs- Raised Pavement Markers  
O.C.- On Center



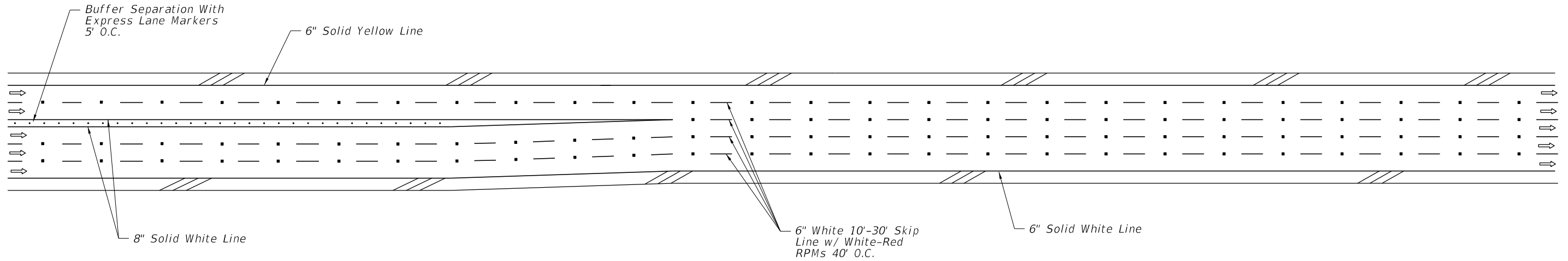
**Express Lane Begins**

RPMs- Raised Pavement Markers  
O.C.- On Center

NOT TO SCALE

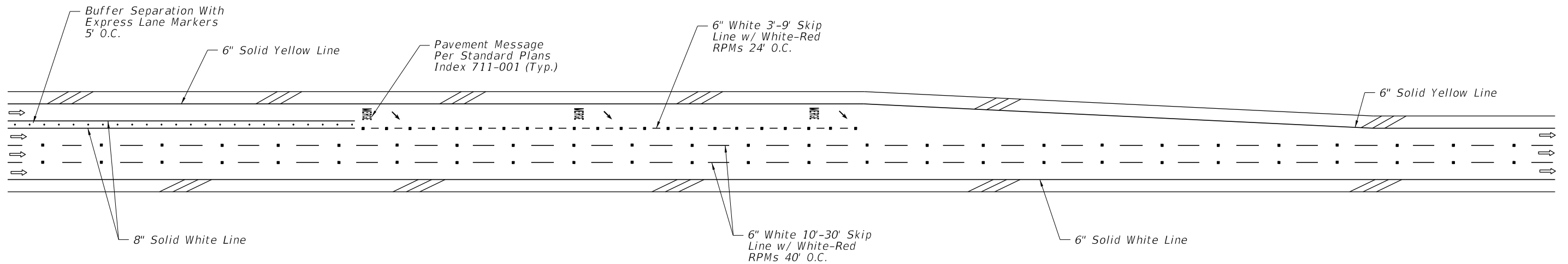
EXHIBIT 211-11  
01/01/2019

# EXPRESS LANES TYPICAL PAVEMENT MARKINGS FOR END EXPRESS LANES



*Express Lanes Become General Purpose Lanes*

RPMs- Raised Pavement Markers  
O.C.- On Center



*Express Lane Ends*

RPMs- Raised Pavement Markers  
O.C.- On Center

NOT TO SCALE

EXHIBIT 211-12  
01/01/2019

## 211.15 Limited Access Right of Way

The following criteria will be used in establishing Limited Access limits along crossroads at interchanges:

- (1) For rural interchanges, LA R/W will extend along the crossroad a minimum distance of 300 feet beyond the end of the acceleration or deceleration taper. Where no taper is used, the LA R/W will extend a minimum distance of 300 feet beyond the radius point of the return. LA R/W will end at that the same station for both sides of the crossroad based on the greatest distance from the LA facility.
- (2) For interchanges in urban areas, the criteria given above will apply except that the LA R/W will end a minimum of 100 feet beyond the end of taper or the radius point of the return.
- (3) Extend LA R/W for queue spillback on the arterial within interchanges of arterials and LA facilities.
- (4) For unsymmetrical interchanges such as half-diamonds and partial clover leaves, the LA R/W along the crossroad on that side having no ramp will extend to a point opposite that point controlled by the ramp.
- (5) Extend LA R/W along crossroads overpassing LA facilities (no interchange) approximately 200 feet from the LA facility R/W line. This distance may be reduced or omitted if the crossroad profile provides adequate sight distance for existing or proposed driveways. The fence is generally tied into the crossroad structure end bent unless required along the crossroad.

Any reduction in the values shown above for LA R/W limits must be approved by FHWA for interstate projects and by the District Design Engineer for non-interstate facilities.

## 211.16 Maintenance Access

Accommodation of access for maintenance is integral to the roadway typical section on LA facilities. Specific requirements for the area immediately adjacent to toll sites is contained within the General Tolling Requirements (GTR). Requirements for access through various roadside safety devices is contained within **FDM 215**.

Along ramps and mainline lanes where roadside barriers are used, the minimum border width from the back of a barrier or retaining wall is 10 feet. Provide sufficient access from public R/W that is contiguous and unimpeded to the LA facility for maintenance vehicles.



If the maintenance access is not continuous along a barrier or wall, and thus maintenance vehicles and equipment would need to turn around, then a sufficient turnaround area must be provided that is acceptable and approved by the District Maintenance Engineer.

Maintenance accessibility includes the ability for equipment and vehicles to maneuver around obstacles including fences, lights, signs, side slopes, and ponds.