

TYPICAL SECTION THRU SUPERSTRUCTURE WITH CROWN

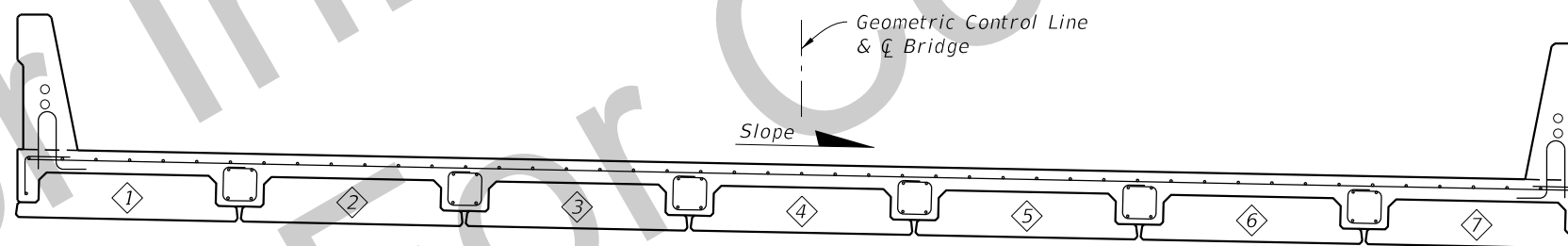

TYPICAL SECTION THRU SUPERSTRUCTURE WITH CONSTANT CROSS SLOPE
(SEE SECTION WITH CROWN ABOVE FOR ALL INFORMATION NOT SHOWN IN THIS SECTION)

- NOTES:
1. See Structure Plans General Notes for Topping minimum thickness and cover.
 2. Work this Index with Index D30000.

SUPERSTRUCTURE TYPICAL SECTION

10/16/2016 10:26:55 AM

LAST REVISION
10/01/16

REVISION

DESCRIPTION:



DEVELOPMENTAL
DESIGN STANDARDS

FSB SUPERSTRUCTURE PACKAGE
32 FT. CLEAR WIDTH

INDEX NO.
D30032

SHEET NO.
1 of 4

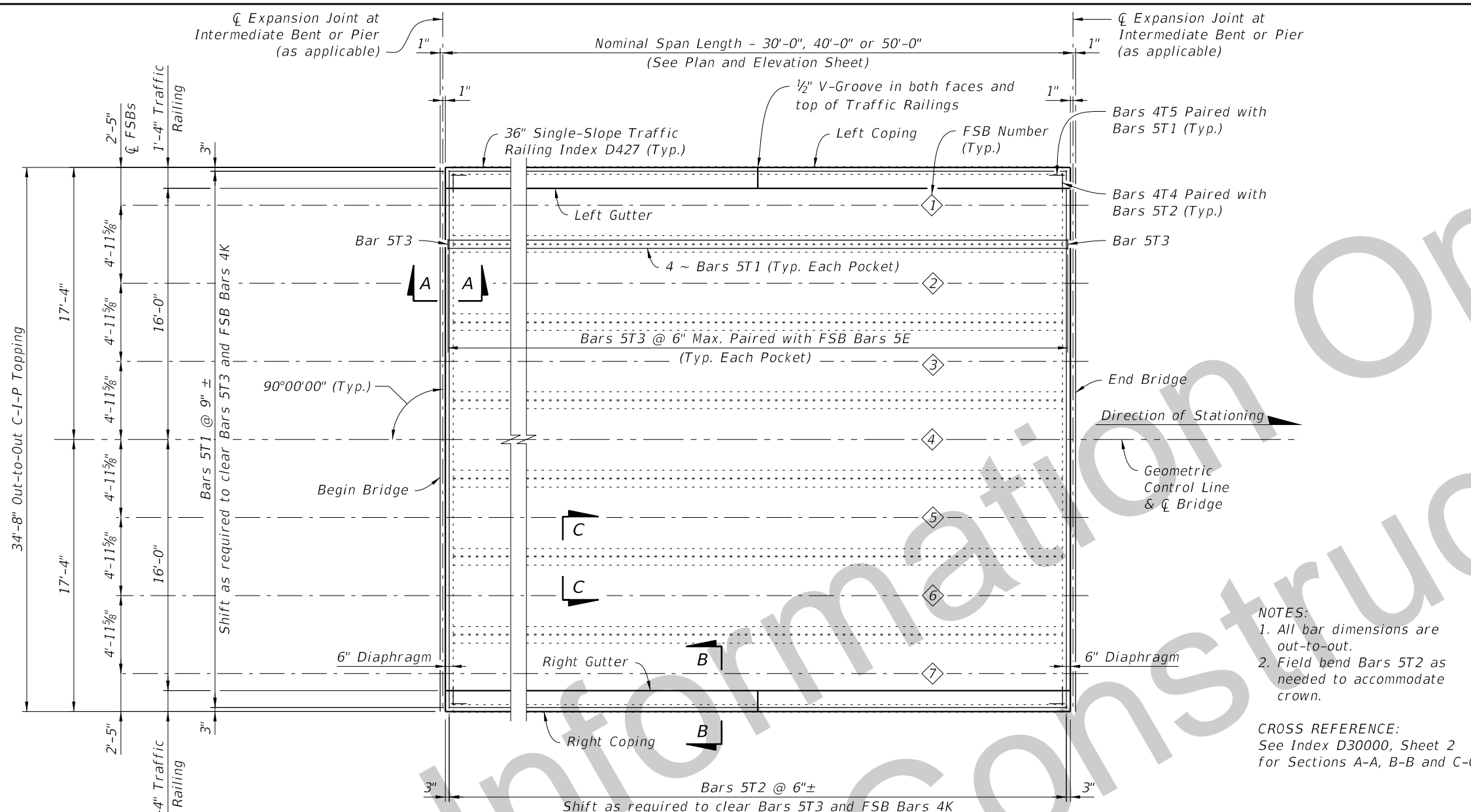

SUPERSTRUCTURE PLAN
(ONE SPAN SHOWN)

BILL OF REINFORCING STEEL FOR ONE SPAN ONLY

NOMINAL SPAN LENGTH	MARK		LENGTH	NO. OF BARS	B	C
	SIZE	DES				
30'-0"	5	T1	29'-6"	73	29'-6"	
	5	T2	34'-4"	62	34'-4"	
	5	T3	4'-2"	360	9½"	9½"
	4	T4	2'-2"	120	1'-6"	8"
40'-0"	4	T5	2'-6"	94	1'-6"	1'-0"
	5	T1	39'-6"	73	39'-6"	
	5	T2	34'-4"	82	34'-4"	
	5	T3	4'-2"	480	9½"	9½"
50'-0"	4	T4	2'-2"	160	1'-6"	8"
	4	T5	2'-6"	94	1'-6"	1'-0"
	5	T1	49'-6"	73	49'-6"	
	5	T2	34'-4"	102	34'-4"	
50'-0"	5	T3	4'-7"	600	1'-0"	9½"
	4	T4	2'-5"	200	1'-6"	11"
50'-0"	4	T5	2'-9"	94	1'-6"	1'-3"

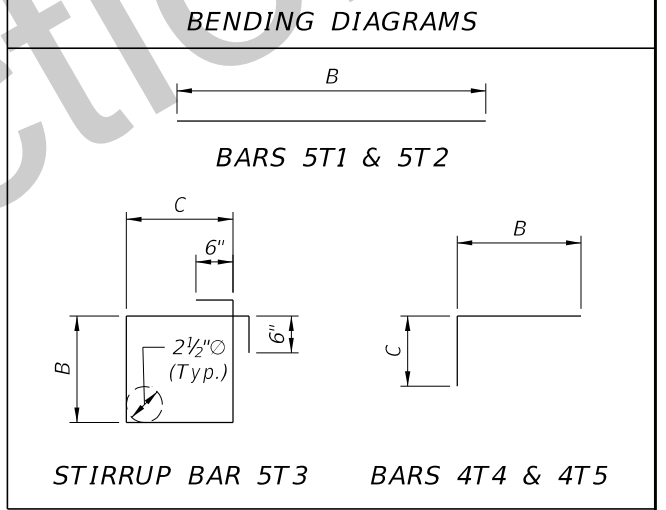

NOTES:
 1. All bar dimensions are out-to-out.
 2. Field bend Bars 5T2 as needed to accommodate crown.

CROSS REFERENCE:
 See Index D30000, Sheet 2 for Sections A-A, B-B and C-C.

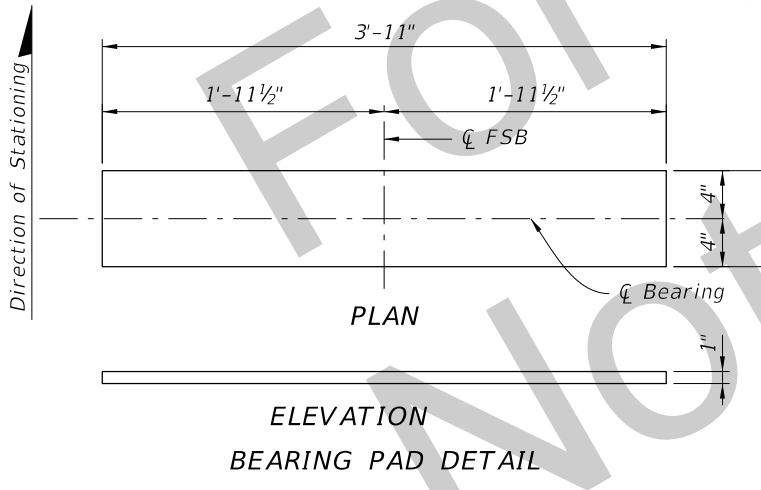

NOTE:
 Provide plain elastomeric Bearing Pads with a Shear Modulus G = 110psi and in accordance with Specification Section 932.

FLORIDA SLAB BEAM - CAMBER AND DEFLECTION DATA TABLE

SPAN LENGTH (ft.)	BEAM NO.	NET BEAM CAMBER (PRESTRESS - DEAD LOAD OF BEAM) @ 120 DAYS (in.)	DIM D DEAD LOAD DEFLECTION DUE TO TOPPING POUR @ 120 DAYS (in.)
30	1-7	½"	⅛"
40	1-7	¾"	⅝"
50	1-7	1 ⅛"	⅞"

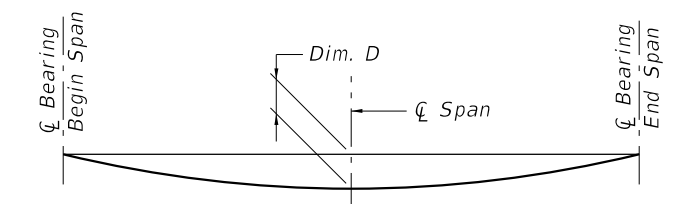

CAMBER NOTE:
 The values given in the table are based on theoretical beam cambers. The Contractor shall monitor beam cambers for the purpose of predicting camber values at the time of the topping casting. If the predicted cambers based on field measurements differ more than ± ½" from the theoretical "Net Beam Camber @ 120 Days" shown in the table, propose modified dimensions as required and submit to the Engineer for approval a minimum of 21 days prior to casting topping concrete.

SUPERSTRUCTURE PLAN

10/16/2016 10:26:55 AM

LAST REVISION 10/01/16	DESCRIPTION:	DEVELOPMENTAL DESIGN STANDARDS	FSB SUPERSTRUCTURE PACKAGE 32 FT. CLEAR WIDTH	INDEX NO. D30032	SHEET NO. 2 of 4

FLORIDA SLAB BEAM - TABLE OF VARIABLES

NOMINAL SPAN LENGTH	LOCATION BEAM NO.	BEAM TYPE	CONCRETE PROPERTIES		STND. PTRN. TYPE	PLAN VIEW CASE		ANGLE θ		BEAM DIMENSIONS*			REINFORCING STEEL																						
			CLASS	STRENGTHS (psi)		END 1	END 2	END 1	END 2	DIM W	DIM L	DIM R	3C		4D1		4D2		4D3		5E1		5E2		6Y1		6Y2		4K		NO. OF BAR SPACES		BAR SPACING*		
				28 Day									Release	NO.	DIM C	DIM D	DIM D	NO.	DIM D	NO.	DIM E	NO.	DIM E	DIM Y	DIM Y	NO.	S1	S2	V1	V2					
30'	1,7	FSB 12x59	VI	8500	6000	1	1	1	90°	90°	4'-11"	28'-10 $\frac{1}{4}$ "	$\frac{1}{4}$ "	31	4'-6 $\frac{1}{2}$ "	2'-5 $\frac{1}{2}$ "	2'-5 $\frac{1}{2}$ "	24	2'-5 $\frac{1}{2}$ "	-	-	57	4'-7 $\frac{1}{2}$ "	3'-6 $\frac{1}{2}$ "	3'-6 $\frac{1}{2}$ "	84	1	8	1'-6"	1'-6"					
	2-6	FSB 12x59	VI	8500	6000	1	1	1	90°	90°	4'-11"	28'-10 $\frac{1}{4}$ "	$\frac{1}{4}$ "	31	4'-6 $\frac{1}{2}$ "	2'-5 $\frac{1}{2}$ "	2'-5 $\frac{1}{2}$ "	24	2'-5 $\frac{1}{2}$ "	57	4'-9"	-	-	3'-6 $\frac{1}{2}$ "	3'-6 $\frac{1}{2}$ "	84	1	8	1'-6"	1'-6"					
40'	1,7	FSB 12x59	VI	8500	6000	2	1	1	90°	90°	4'-11"	38'-10 $\frac{3}{8}$ "	$\frac{3}{8}$ "	41	4'-6 $\frac{1}{2}$ "	2'-5 $\frac{1}{2}$ "	2'-5 $\frac{1}{2}$ "	32	2'-5 $\frac{1}{2}$ "	-	-	77	4'-7 $\frac{1}{2}$ "	3'-6 $\frac{1}{2}$ "	3'-6 $\frac{1}{2}$ "	156	8	10	6"	1'-6"					
	2-6	FSB 12x59	VI	8500	6000	2	1	1	90°	90°	4'-11"	38'-10 $\frac{3}{8}$ "	$\frac{3}{8}$ "	41	4'-6 $\frac{1}{2}$ "	2'-5 $\frac{1}{2}$ "	2'-5 $\frac{1}{2}$ "	32	2'-5 $\frac{1}{2}$ "	77	4'-9"	-	-	3'-6 $\frac{1}{2}$ "	3'-6 $\frac{1}{2}$ "	156	8	10	6"	1'-6"					
50'	1,7	FSB 15x59	VI	8500	6000	3	1	1	90°	90°	4'-11"	48'-10 $\frac{1}{2}$ "	$\frac{1}{2}$ "	51	4'-6 $\frac{1}{2}$ "	2'-5 $\frac{1}{2}$ "	2'-5 $\frac{1}{2}$ "	44	2'-5 $\frac{1}{2}$ "	-	-	97	4'-7 $\frac{1}{2}$ "	3'-6 $\frac{1}{2}$ "	3'-6 $\frac{1}{2}$ "	148	4	13	1'-0"	1'-6"					
	2-6	FSB 15x59	VI	8500	6000	3	1	1	90°	90°	4'-11"	48'-10 $\frac{1}{2}$ "	$\frac{1}{2}$ "	51	4'-6 $\frac{1}{2}$ "	2'-5 $\frac{1}{2}$ "	2'-5 $\frac{1}{2}$ "	44	2'-5 $\frac{1}{2}$ "	97	4'-9"	-	-	3'-6 $\frac{1}{2}$ "	3'-6 $\frac{1}{2}$ "	148	4	13	1'-0"	1'-6"					

NOTE: Work this sheet with Developmental Design Standards Index D20450.

DIMENSION NOTES

* All longitudinal slab beam dimensions shown on this sheet with a single asterisk (*) are measured along the top of beam at the centerline. Dimension "R" is calculated at mid-height of the slab beam.

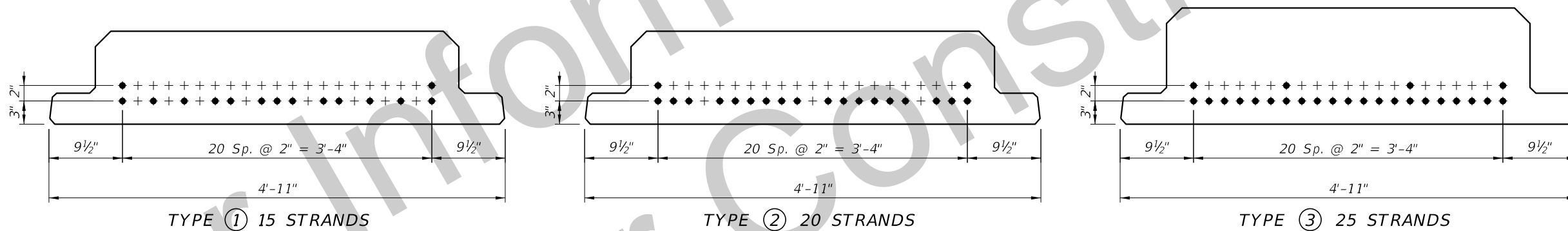

STRAND DESCRIPTION: Use 0.60" Diameter, Grade 270, Low Relaxation Carbon Steel Strands stressed at 44.0 kips each. Area per strand equals 0.217 sq. in.

STRAND DEBONDING LEGEND
● - fully bonded strands.

STRAND PATTERNS

10/16/2016 10:26:56 AM

FLORIDA SLAB BEAM - TABLE OF VARIABLES

LAST REVISION 10/01/16	DESCRIPTION:	DEVELOPMENTAL DESIGN STANDARDS	FSB SUPERSTRUCTURE PACKAGE 32 FT. CLEAR WIDTH	INDEX NO. D30032	SHEET NO. 3 of 4
---------------------------	--------------	--------------------------------	--	---------------------	---------------------

Load Rating Summary Details for Prestressed Concrete Bridges (Flat Slab and Deck/Girder)

Table 2 - LRFR

Span Length (Ft)	Level	Limit State	Vehicle	Weight (tons)	Load Factors			Moment (Strength) or Stress (Service)					Shear (Strength)					Comments: Interior/exterior beam DF method if other than LRFD. Other appropriate comments
					LL	DC	DW	Distribution Factor (DF)	Rating Factor	Tons	Location	Dimension (Ft)	Distribution Factor (DF)	Rating Factor	Tons	Location	Dimension (Ft)	
30	Design Load Rating	Strength I (Inv)	HL-93	N/A	1.75	1.25	1.50	0.45	1.95	N/A	C	13.32	0.71	4.40	N/A	A	1.39	Exterior Beam
		Strength I (Op)	HL-93	N/A	1.35	1.25	1.50	0.45	2.53	N/A	C	13.32	0.71	5.70	N/A	A	1.39	Exterior Beam
		Service III (Inv)	HL-93	N/A	0.80	1.00	1.00	0.45	1.92	N/A	C	13.32	N/A	N/A	N/A	N/A	N/A	Exterior Beam
	Permit Load Rating	Strength II	FL120	60.0	1.35	1.25	1.50	0.45	2.14	128.59	B	10.54	0.71	3.86	231.88	A	1.39	Exterior Beam
40	Design Load Rating	Strength I (Inv)	HL-93	N/A	1.75	1.25	1.50	0.42	1.60	N/A	C	18.50	0.69	4.56	N/A	A	4.15	Exterior Beam
		Strength I (Op)	HL-93	N/A	1.35	1.25	1.50	0.42	2.08	N/A	C	18.50	0.69	5.91	N/A	A	4.15	Exterior Beam
		Service III (Inv)	HL-93	N/A	0.80	1.00	1.00	0.42	1.15	N/A	C	18.50	N/A	N/A	N/A	N/A	N/A	Exterior Beam
	Permit Load Rating	Strength II	FL120	60.0	1.35	1.25	1.50	0.42	1.56	93.46	B	16.99	0.69	4.07	244.31	A	4.15	Exterior Beam
50	Design Load Rating	Strength I (Inv)	HL-93	N/A	1.75	1.25	1.50	0.41	1.58	N/A	C	22.44	0.67	4.57	N/A	A	1.43	Exterior Beam
		Strength I (Op)	HL-93	N/A	1.35	1.25	1.50	0.41	2.05	N/A	C	22.44	0.67	5.92	N/A	A	1.43	Exterior Beam
		Service III (Inv)	HL-93	N/A	0.80	1.00	1.00	0.41	1.12	N/A	C	22.92	N/A	N/A	N/A	N/A	N/A	Exterior Beam
	Permit Load Rating	Strength II	FL120	60.0	1.35	1.25	1.50	0.41	1.52	90.96	B	21.49	0.67	4.23	253.91	A	1.43	Exterior Beam

- NOTES:
1. Permit capacity is determined by using the permit vehicle in all lanes.
 2. Service III Design Inventory tensile stress limits = $3\sqrt{f'c}$.
 3. Has the AASHTO LRFD Specifications Article 5.8.3.5 longitudinal reinforcement been satisfied? Yes No

Abbreviations:
Inv - Inventory
Op - Operating

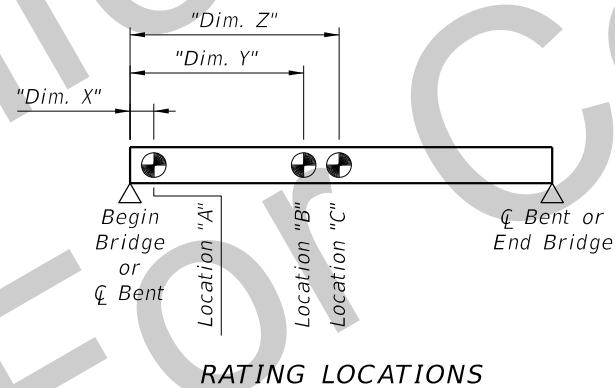

10/6/2016 10:26:57 AM

LOAD RATING SUMMARY SHEET

LAST REVISION 10/01/16	DESCRIPTION:	DEVELOPMENTAL DESIGN STANDARDS	FSB SUPERSTRUCTURE PACKAGE 32 FT. CLEAR WIDTH	INDEX NO. D30032	SHEET NO. 4 of 4
---------------------------	--------------	---------------------------------------	--	---------------------	---------------------