

PRESTRESSED SLAB UNIT (PSU) FABRICATION NOTES

1. All bar dimensions are out-to-out.
2. Strands N shall be ASTM A416, Grade 250 or 270, $\frac{3}{8}$ " \emptyset or larger, stressed to 10,000 lbs. each.
3. Unless otherwise noted, the minimum concrete cover for reinforcing steel shall be 2".
4. For slab units with skewed end conditions, the end reinforcement, defined as Bars 4D1, 4D2, 4K and Y within the limits of the first 2'-0", shall be placed parallel to the skewed ends of the slab unit. The next two sets of Bars 4D1 or 4D2 & 4K shall be fanned to provide equal spacing. Provide additional Bars 4D1 or 4D2 for end skews $\geq 10^\circ$. See "SKEWED END TREATMENT DETAIL".
5. Bars 4D1, 4D2, 4D3 & 4K shall be placed and tied to Strands N and a fully bonded strand in the bottom row. See "STRAND PATTERNS".
6. At the Contractor's option, deformed welded wire reinforcement may be used in lieu of Bars 4D and 4K. Submit details to the Engineer for approval.
7. For referenced Dimensions, Angles and Case Numbers, see Table of Variables in Structures Plans.
8. Top surface of the slab units shall be raked transversely to provide a roughened surface with $\frac{1}{4}$ " amplitude, except the top edge adjacent to all keyed joints shall be troweled smooth for bonding of the Crack Arrest Strips. For proper bonding of the deck overlay, clean the top surface of the Prestressed Slab Units, apply Crack Arrest Strips above grouted joints, thoroughly soak top surface with potable water for a minimum of 4 hrs. then remove all excess surface water immediately prior to placement of the overlay.
9. Cut strands 1" beyond the face of the slab unit.
10. Bars 4D1, 5Y1 & 6Y1 correspond to END 1, and 4D2, 5Y2 & 6Y2 correspond to END 2.

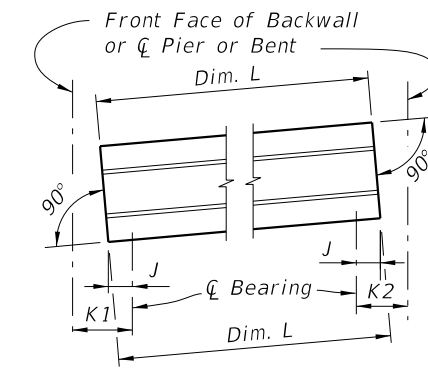

SCHEMATIC SIDE ELEVATION OF SLAB UNITS
(Positive Grade shown, Negative Grade or Horizontal Grade similar)

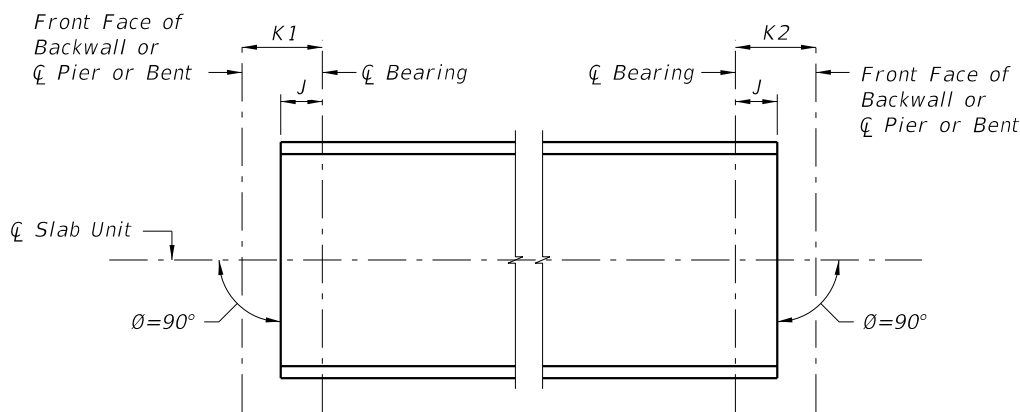
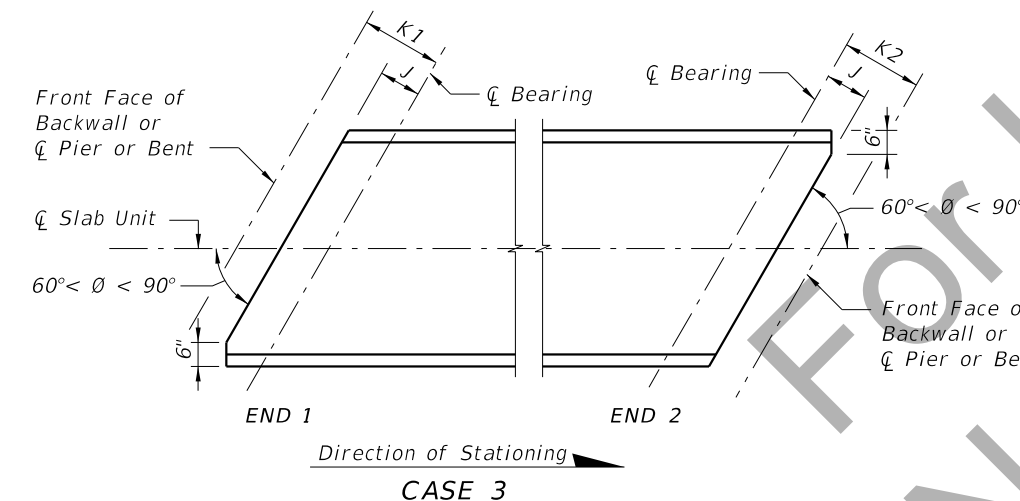
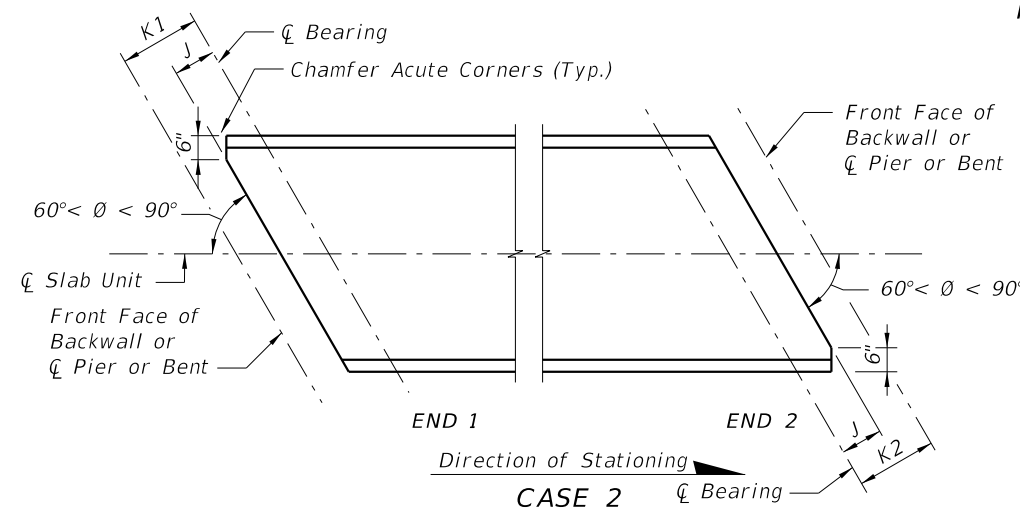

SCHEMATIC PLAN VIEWS AT SLAB ENDS

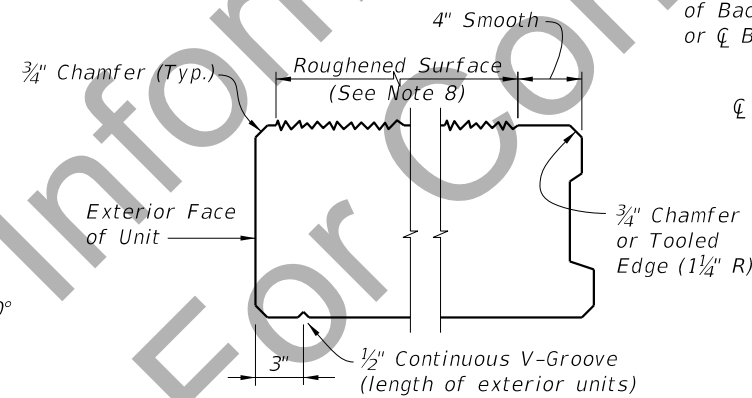

V-GROOVE & TOP SURFACE FINISH DETAILS
(Exterior Unit Shown, Top Surface Finish Similar for Interior Units)

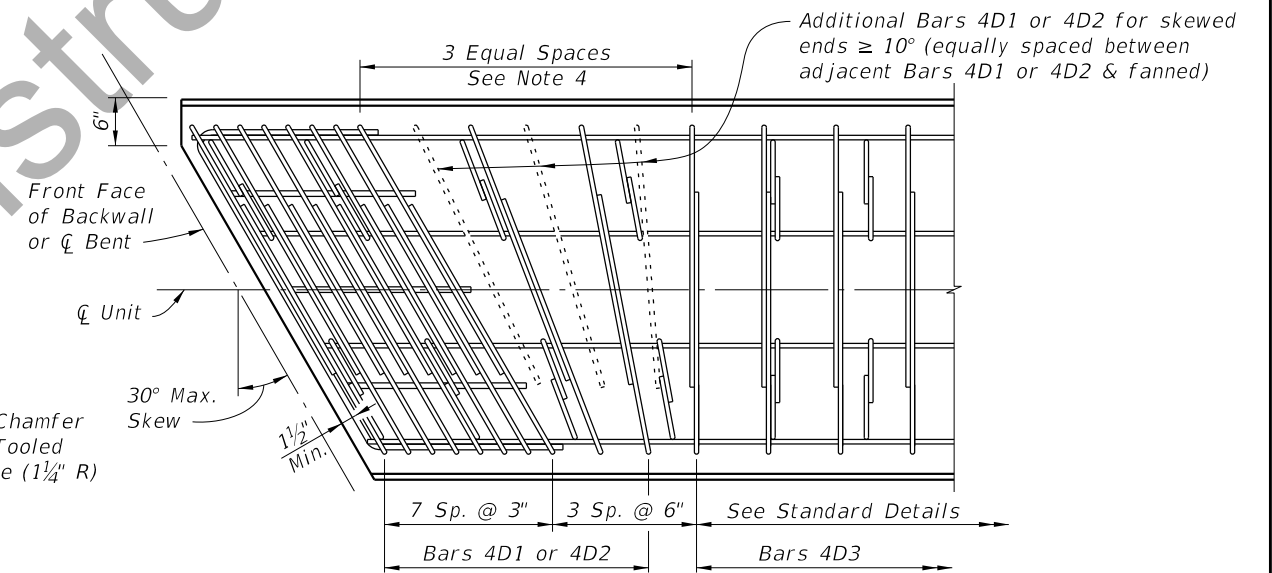

SKEWED END TREATMENT DETAIL

10/29/2014 4:12:49 PM

FABRICATION DETAILS AND NOTES

LAST REVISION 10/29/14	DESCRIPTION:
---------------------------	--------------



DEVELOPMENTAL DESIGN STANDARDS

PRESTRESSED SLAB UNITS

INDEX NO.
D20350

SHEET NO.
1 of 3

RAILING REINFORCING MODIFIED BAR LAYOUT

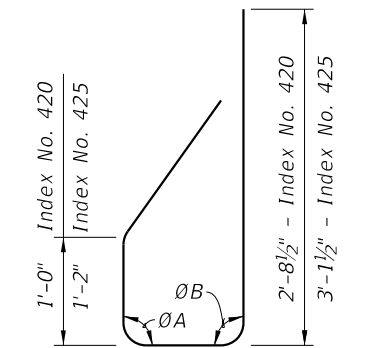

**STIRRUP
BAR 5V (MOD.)
INDEX NOS. 420 OR 425**

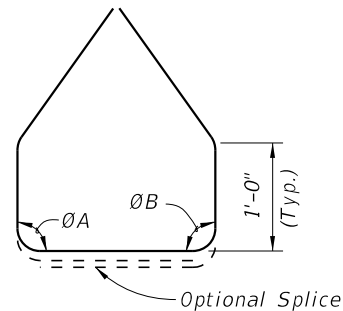

**STIRRUP
BAR 5W (MOD.)
INDEX NO. 421**

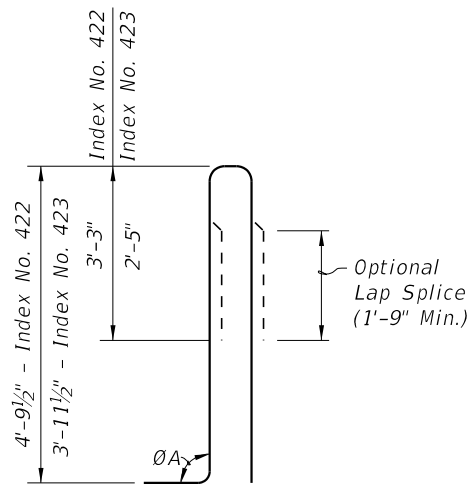

**STIRRUP
BAR 5T (MOD.)
INDEX NOS. 422 OR 423**

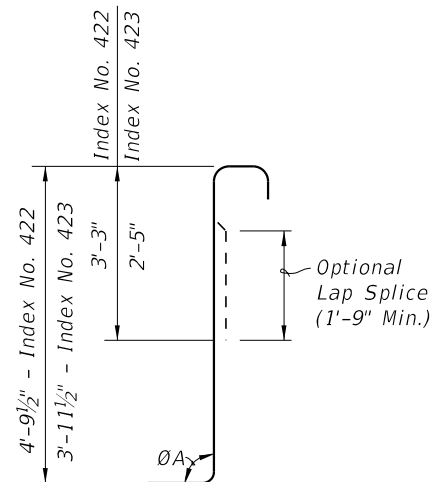

**STIRRUP
BAR 5X (MOD.)
INDEX NOS. 422 OR 423**

REINFORCING STEEL NOTES:

1. Bar dimensions shown are out to out.
2. For the other dimensions and angles ØA and ØB, see the referenced Index.
3. Adjust the dimension shown for Bars 5V, 5T, 5W, 5X, 4P, 4V & 7P as required when the Minimum Overlay is thickened to accommodate superelevation transition or for other reasons.
4. The 4'-9 1/2" (Index No. 422), 3'-11 1/2" (Index No. 423) vertical dimension shown for Bars 5T and 5X is based on a 6" thick deck Overlay with a 6" thick x 6' wide raised sidewalk on low side of the deck with a 2% deck cross slope and a counter 2% raised sidewalk cross slope. If the raised sidewalk thickness, width, or cross slope varies from the above amounts, adjust this dimension accordingly to achieve a 2 3/4" embedment (± 1/2") into the slab units. See Structures Plans, Superstructure and Approach Slab Sheets.
5. All reinforcing steel at the open joints shall have a 2" minimum cover.
6. Bars 5S may be continuous or spliced at the mid point of the slab unit. Bar splices for Bars 5S shall be a minimum of 2'-0".
7. Welded Wire Reinforcement is not permitted for Bars 5W (Mod.) on precast slab units.

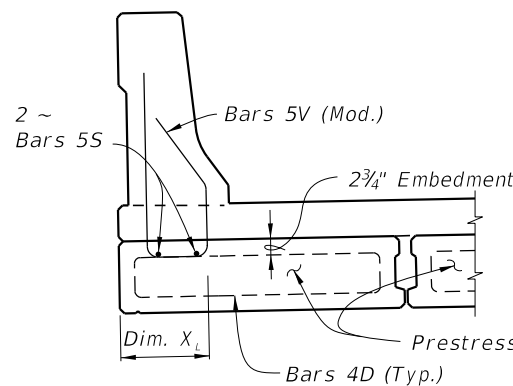

CASE "LEFT"

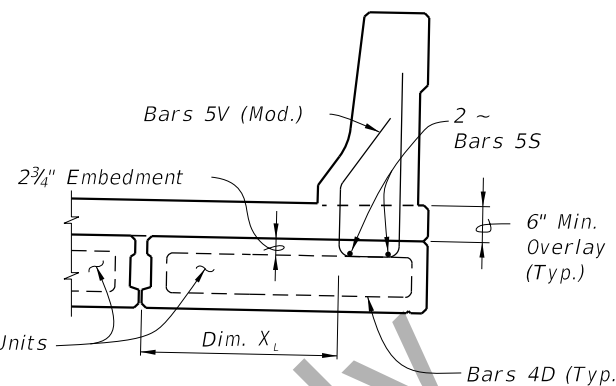

CASE "RIGHT"

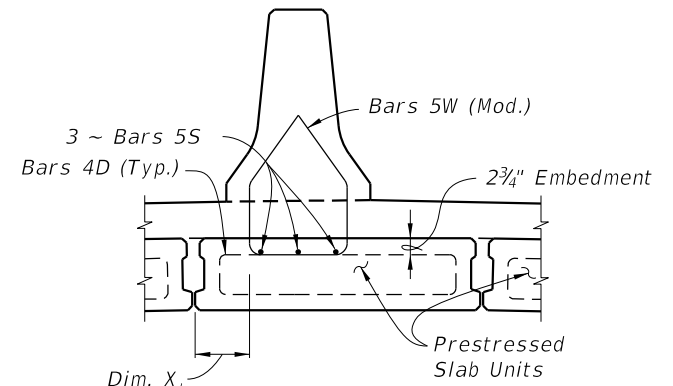

CASE "INTERIOR"

**F SHAPE TRAFFIC RAILING (LOOKING AHEAD STATION)
(Index No. 420 - 32" F Shape shown)
(Index No. 425 - 42" F Shape similar)**

(Railing on Exterior Units shown, Railing on Interior Units similar)

NOTES:

1. Work this sheet with the Prestressed Slab Unit - Table of Variables and Prestressed Slab Unit - Traffic Railing Reinforcement Layout Table (if required) in the Structures Plans.
2. Contractor shall direct the Precaster on how the Traffic Railing bars 5V and 5W are to be placed, either vertical (plumb) or perpendicular to the cross slope to allow proper placement of the modified railing bars.
3. Modified Bars 5T & 5X for Index Nos. 422 & 423 shall be placed vertical (plumb).
4. For skewed Prestressed Slab Units, place the bottom leg of vertical railing bars parallel to transverse slab reinforcement bars at unit ends. See Skewed End Treatment Detail, Sheet 1.
5. Concrete cover at top of railings may be increased up to 1" to accommodate camber of prestressed slab units.

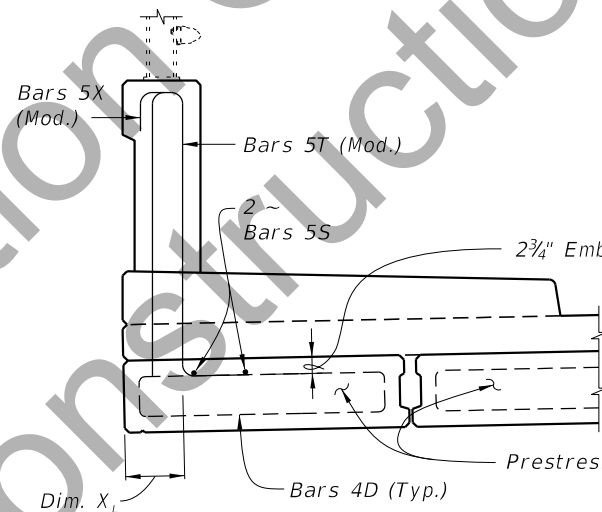

CASE "LEFT"

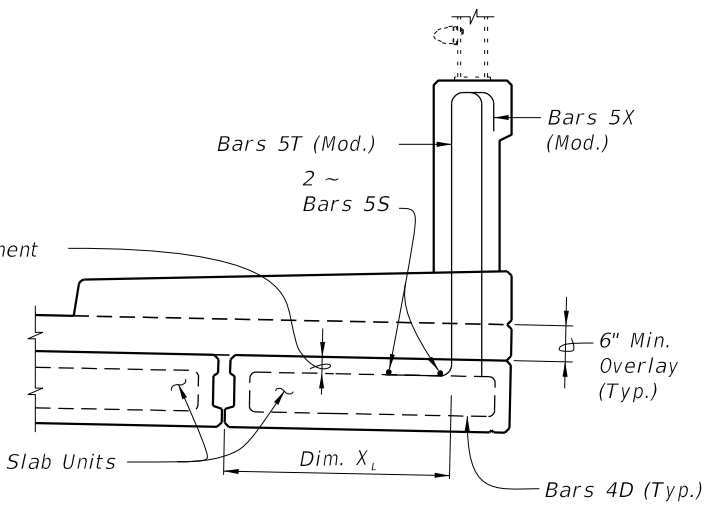

CASE "RIGHT"

**VERTICAL SHAPE TRAFFIC RAILING (LOOKING AHEAD STATION)
(Index No. 423 - 32" Vertical Shape shown)
(Index No. 422 - 42" Vertical Shape similar)**

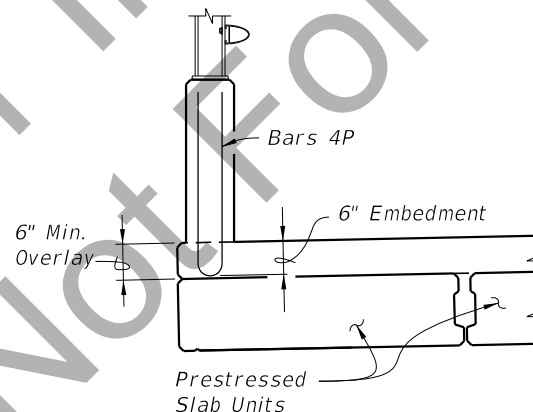

**BRIDGE PEDESTRIAN/BICYCLE
BULLET RAILING DETAIL
(Index No. 820)**

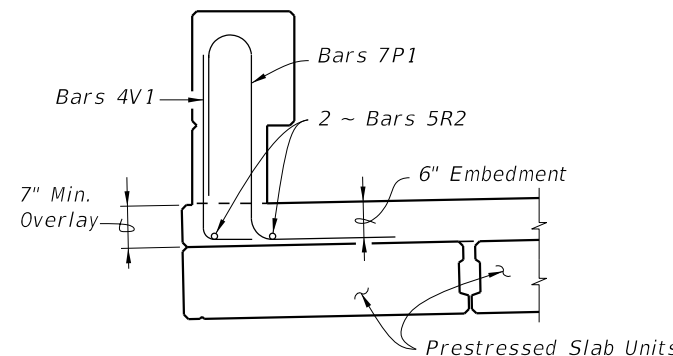

**TRAFFIC RAILING - (CORRAL SHAPE)
(Index No. 424)**

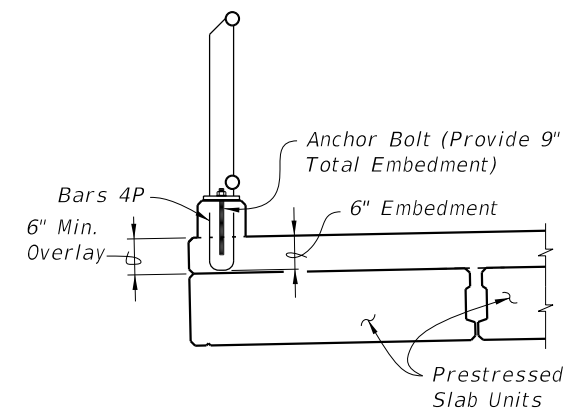

**BRIDGE PEDESTRIAN/BICYCLE
PICKET RAILING
(Index Nos. 851 & 861)**

FILES
USERS
STIMES
SDATES

LAST REVISION 04/28/14	DESCRIPTION:
---------------------------	--------------



**DEVELOPMENTAL
DESIGN STANDARDS**

PRESTRESSED SLAB UNITS

INDEX NO.
D20350

SHEET NO.
2 of 3

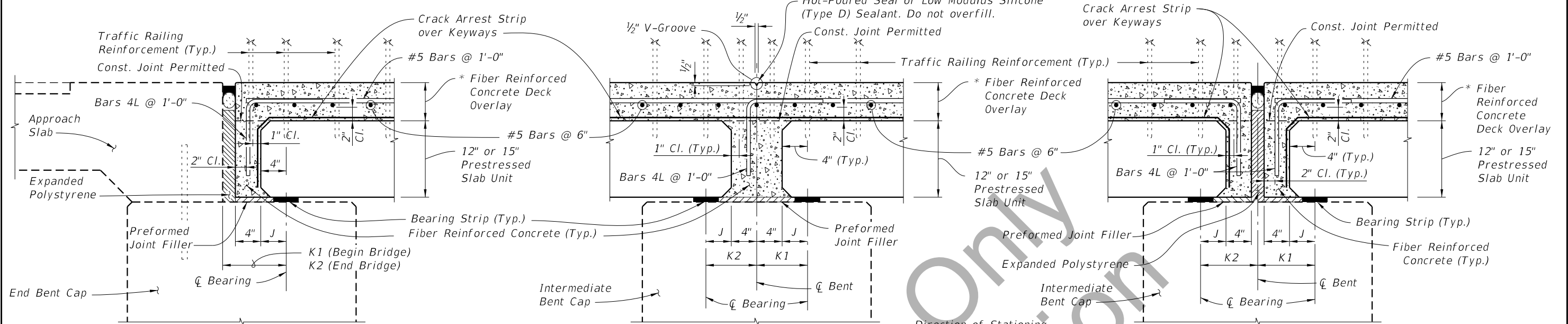

JOINT DETAIL AT BEGIN/END BRIDGE

JOINT DETAIL AT INTERMEDIATE BENTS WITHOUT EXPANSION JOINT

JOINT DETAIL AT EXPANSION INTERMEDIATE BENTS

NOTE:
Deck overlay reinforcing is shown at nominal spacing. See Structures Plans for actual spacing and orientation on skewed bridges.

* See Overlay & Deflection Data Table for thickness

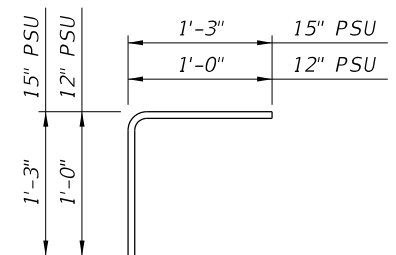

BARS 4L DETAIL

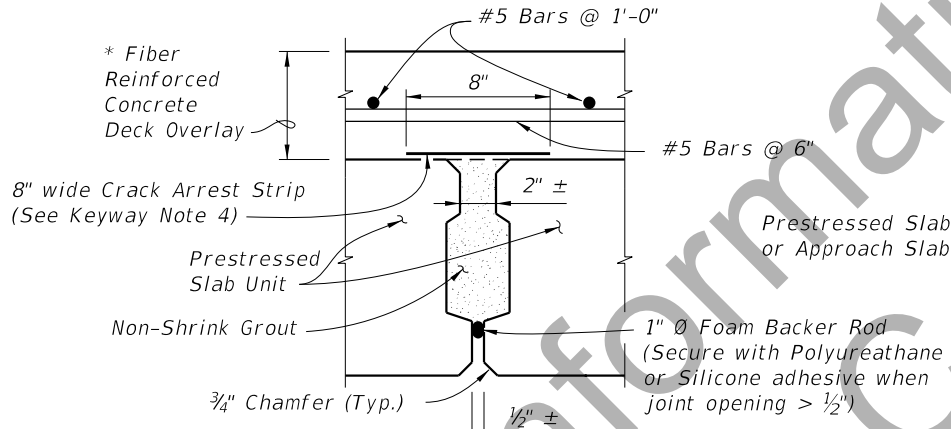

KEYWAY DETAIL

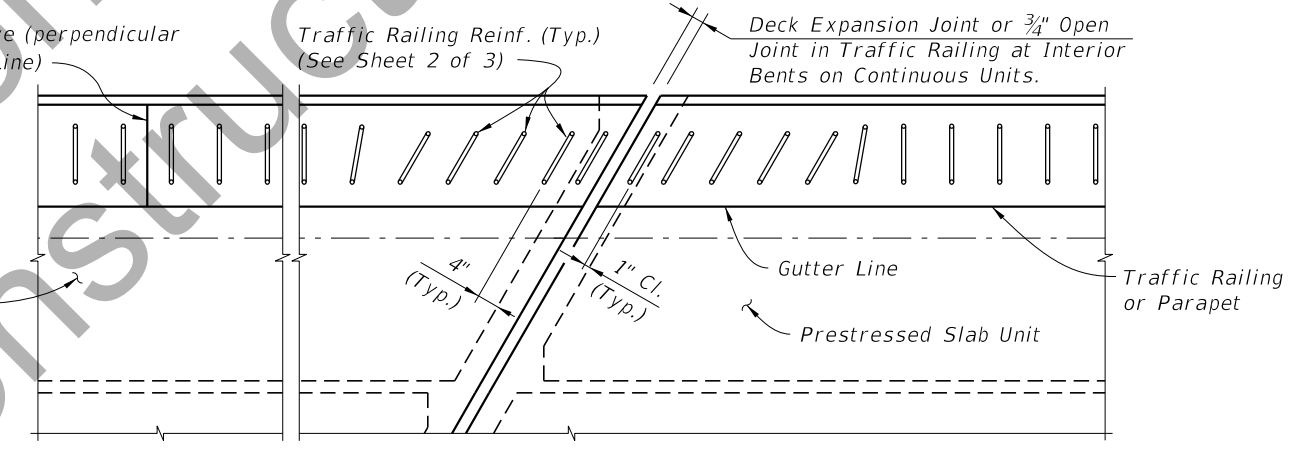

PARTIAL PLAN VIEW OF JOINTS ON SKEWED BRIDGES (EXPANSION JOINT SHOWN, INTERMEDIATE JOINT SIMILAR)

KEYWAY NOTES:

- At every Keyway trowel Non-Shrink Grout level with the top surface of the Prestressed Slab Unit.
- Place an 8" wide Crack Arrest Strip over Keyway for the length of bridge between expansion joints.
- At expansion joints extend Crack Arrest Strip over end of Keyway to 1 1/2" from the bottom of the diaphragm.
- Crack Arrest Strip shall be a maximum of 1/8" thick and meet one of the following:
 - Pre-cured Silicone Sealant meeting Section 932 and on the APL;
 - Mastic, Rubber or Butyl Sealing Bands meeting requirements of ASTM C877;
 - Other equivalent material approved by the Engineer.
- Apply Crack Arrest Strip in accordance with the manufacturer's recommendations.

BEARING STRIP NOTES:

- See "Bearing Strip Data Table" in Structures Plans.
- Provide Bearing Strips in accordance with Specification 932 (Plain Elastomeric Bearing Pads).
- Bearing Strips may be continuous across multiple Prestressed Slab Units.
- Limit Discontinuities of Bearing Strips to a maximum distance of 2 inches from any longitudinal edge of Prestressed Slab Units.
- Provide matching Bearing Strips at each end of Prestressed Slab Units.

REFERENCED DIMENSIONS:

- For Dimensions J, K1 and K2, see Table of Variables in the Structures Plans.
- For Dimensions E and t, see Bearing Strip Data Table in the Structures Plans.

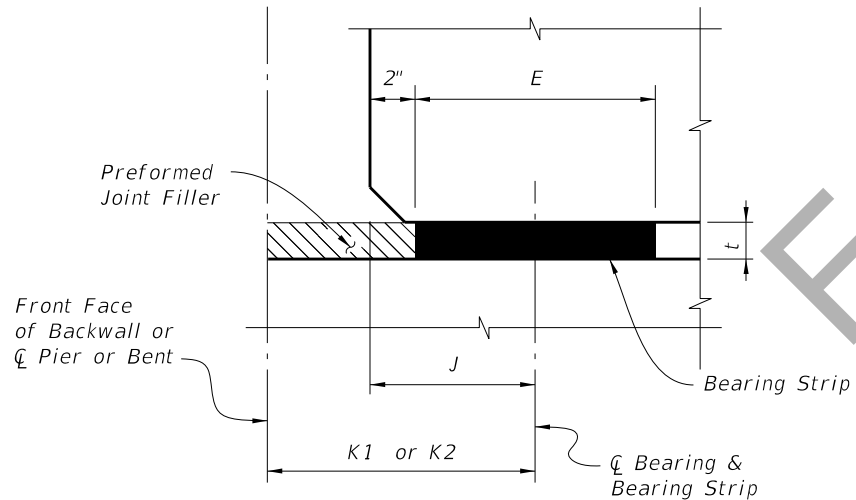

PARTIAL SIDE ELEVATION (ALONG Q BEARING)

10/29/2014 4:15:41 PM

LAST REVISION 10/29/14	DESCRIPTION:	DEVELOPMENTAL DESIGN STANDARDS	PRESTRESSED SLAB UNITS	INDEX NO. D20350	SHEET NO. 3 of 3
---------------------------	--------------	---------------------------------------	-------------------------------	---------------------	---------------------