

**GENERAL NOTES**

**CONSTRUCTION SPECIFICATIONS:**

Florida Department of Transportation "Standard Specifications for Road and Bridge Construction", Current Edition and Supplements as amended. Construct GRS abutments and walls in accordance with Developmental Specification Section 549.

**DESIGN SPECIFICATIONS:**

Geosynthetic Reinforced Soil Integrated Bridge System Interim Implementation Guide, FHWA-HRT-11-026, January 2011 except as amended by the FDOT Structures Manual (current edition).

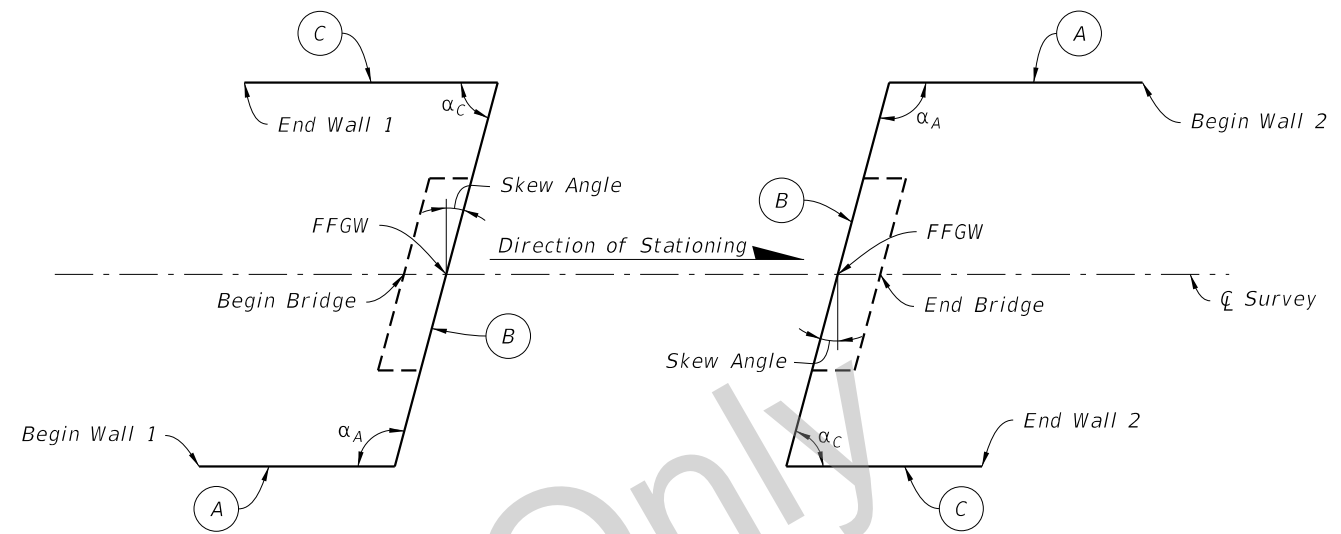

**WALL LABELING DIAGRAM**

**DEFINITION OF VARIABLES**

- $a_b$  = Set back distance between back of facing element and beam seat
- $B$  = Base length of reinforcement
- $b$  = Bearing width for bridge beam seat
- $B_r$  = Length of bearing bed reinforcement
- $B_{RSF}$  = Width of RSF
- $D_b$  = Depth of beam seat
- $d_e$  = Clear space from top of wall to bottom of superstructure
- $D_r$  = Depth of bearing bed
- $D_{RSF}$  = Depth of RSF below bottom of wall elevation
- $D_{tz}$  = Depth of GRS-GAB transition
- $h_{rb}$  = Height of road base (equals height of superstructure and pavement thickness)
- $H$  = GRS Design Height
- $L$  = Length of GRS Backfill Reinforcement
- $L_B$  = Abutment width
- $L_A, L_C$  = Wingwall length
- $S$  = Minimum distance from guardrail  $\zeta$  to back of CMU
- $X_{RSF}$  = Width of RSF in front of the abutment and wingwall wall face
- $\alpha_A, \alpha_C$  = Wingwall angle

**ABBREVIATIONS**

- AOS = Apparent Opening Size
- $B_b$  = Width of the bridge
- $B_{block}$  = Width of CMU =  $7\frac{5}{8}$ "
- CMU = Concrete masonry unit
- $d_{max}$  = Maximum particle diameter in GRS backfill
- FFGW = Front Face of GRS Wall
- GAB = Graded Aggregate Base
- GRS = Geosynthetic Reinforced Soil
- $H_{block}$  = Height of CMU =  $7\frac{5}{8}$ "
- IBS = Integrated Bridge System
- $L$  = Length of GRS Backfill Reinforcement
- $L_{block}$  = Length of CMU =  $15\frac{5}{8}$ "
- RSF = Reinforced soil foundation
- $T_{ult}$  = Design Standards Index 501 Ultimate Tensile Strength
- $T_{2\%}$  = Design Standards Index 501 2% Strain Tensile Strength

For Information Only  
Not For Construction

**GENERAL NOTES**

SDATES

LAST REVISION 04/06/17	REVISION	DESCRIPTION:	<b>DEVELOPMENTAL DESIGN STANDARDS</b>	GRS-IBS	INDEX NO. D6025	SHEET NO. 1 of 10
---------------------------	----------	--------------	---------------------------------------	---------	--------------------	----------------------

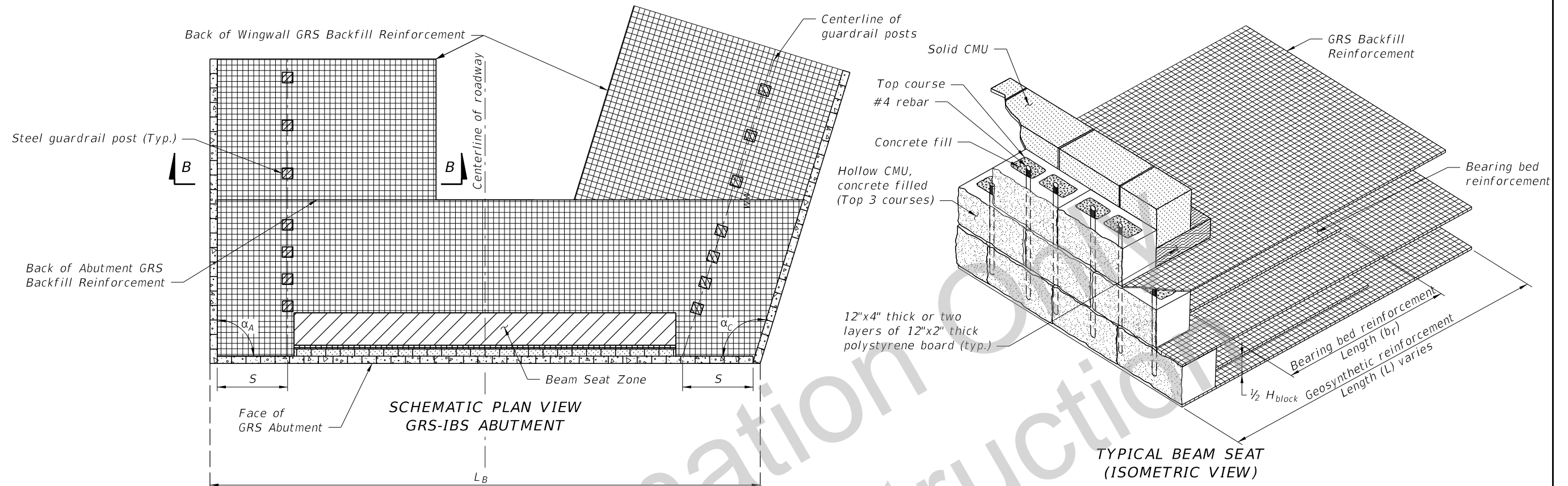

**SCHEMATIC PLAN VIEW  
GRS-IBS ABUTMENT**

**TYPICAL BEAM SEAT  
(ISOMETRIC VIEW)**

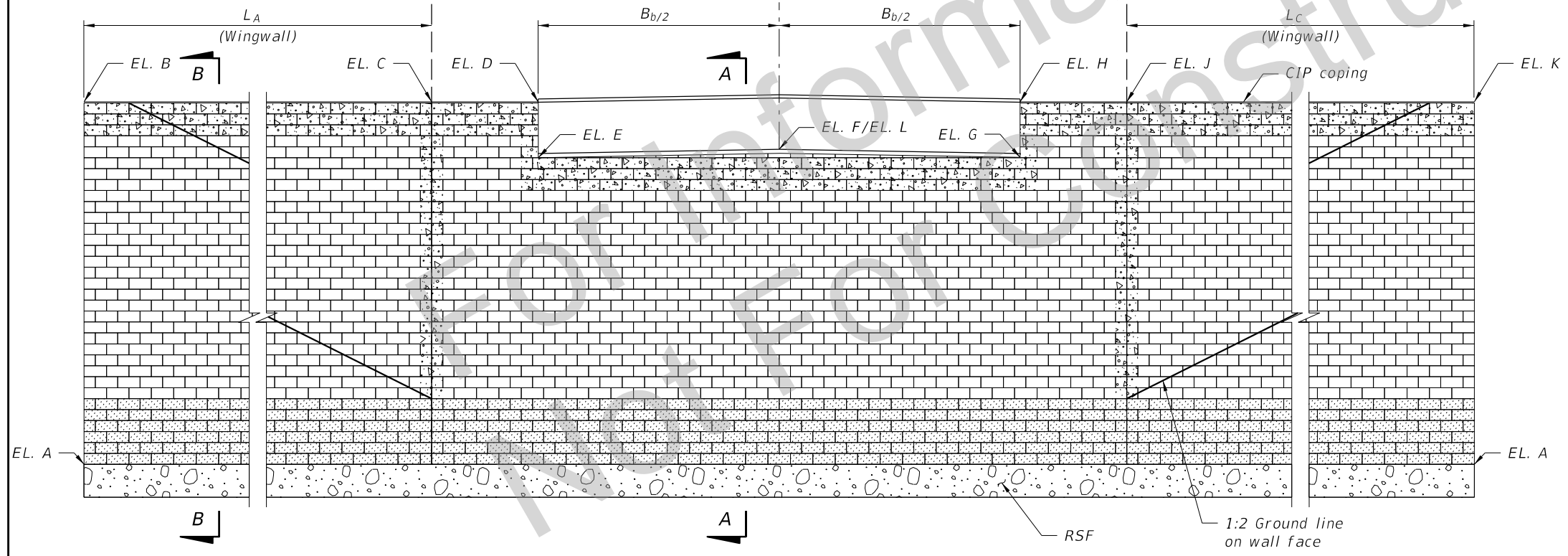





**DEVELOPED SCHEMATIC ELEVATION VIEW  
GRS-IBS ABUTMENT  
Facing Block Schedule**

**NOTES:**

1. CMU blocks are running bond, including corners, so there are no vertical joints greater than one CMU course height.
2. Remove backfill and geotextile from hollow core of the top 3 courses of CMUs and corner CMUs, insert #4 bars, and fill with concrete.
3. Wingwalls are folded out for elevation view.

**LEGEND:**

-  Hollow, textured CMU filled with concrete and rebar
-  Hollow, textured CMU filled with GRS backfill
-  Solid, smooth-faced CMU
-  Graded Aggregate Base (GAB)

SDATES

LAST REVISION	REVISION	DESCRIPTION:
04/28/14		



GRS-IBS

**PLAN AND ELEVATION**

INDEX NO. <b>D6025</b>	SHEET NO. <b>2 of 10</b>
---------------------------	-----------------------------

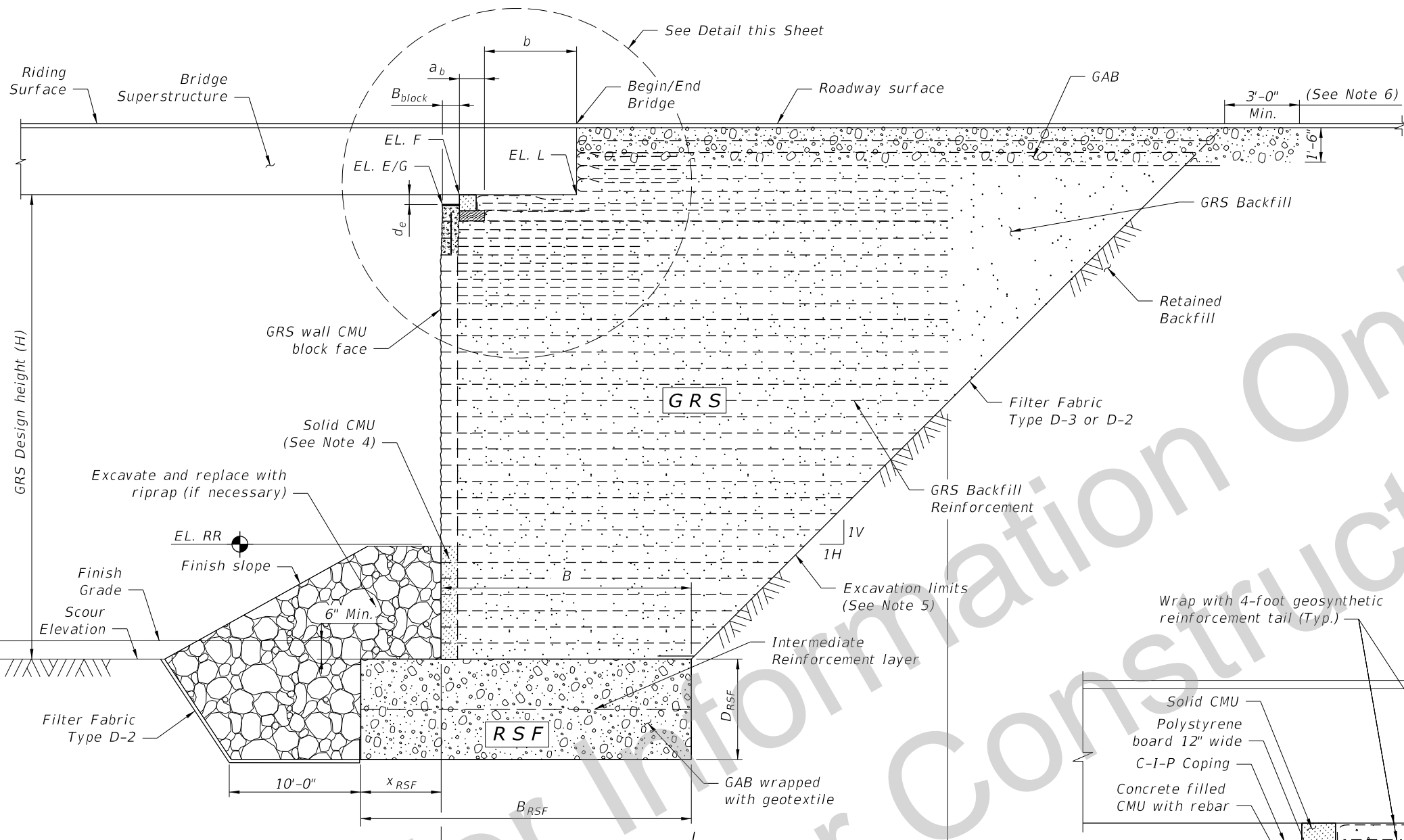

**LEGEND:**

	GRS Backfill
	Graded Aggregate Base (GAB)
	Riprap
	Solid, smooth faced CMU
	Hollow, textured CMU filled with GRS backfill
	Hollow, textured CMU filled with concrete and rebar

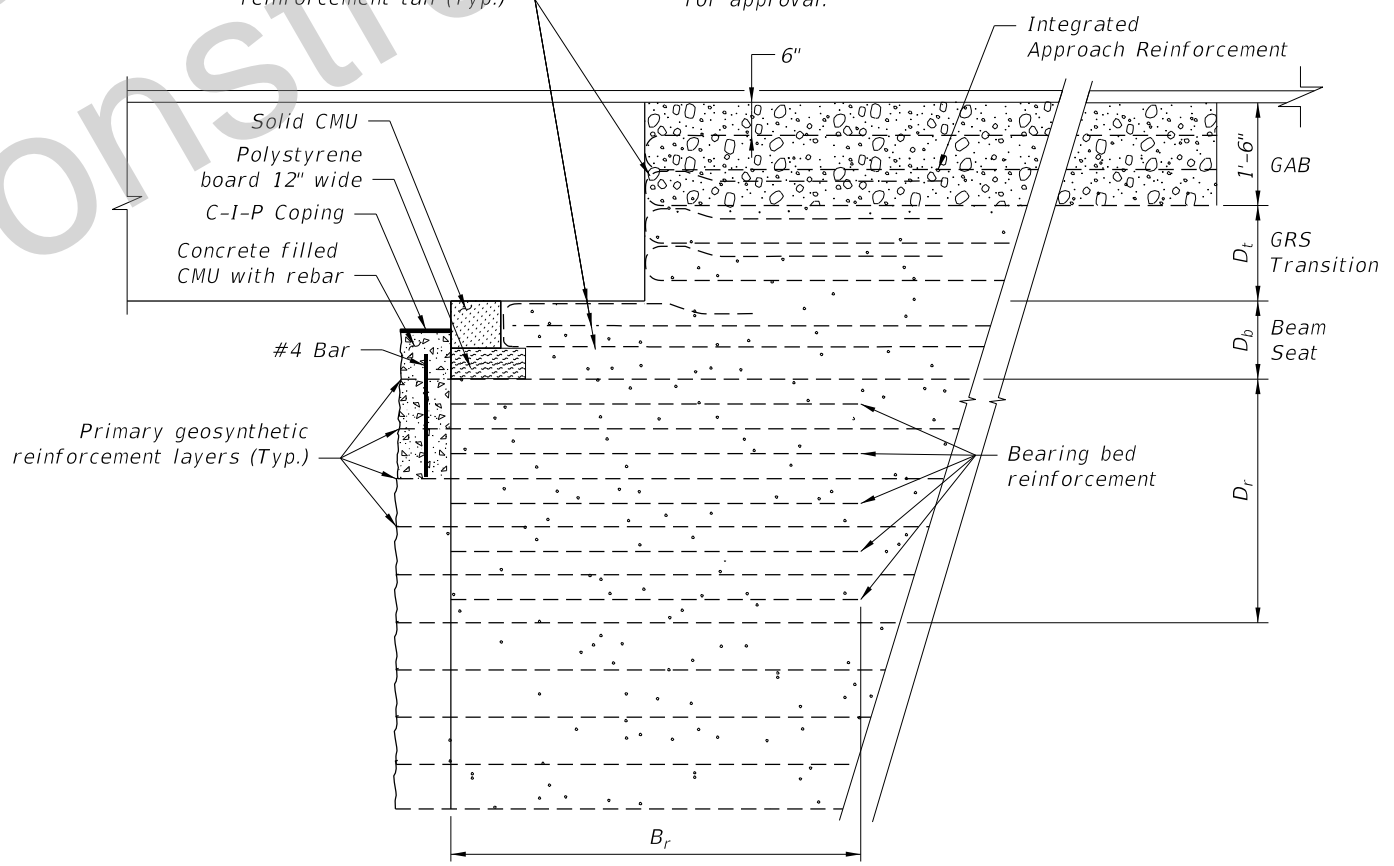

**DETAIL**  
 (Beam seat and integrated approach Detail, Flat Slab shown)  
 See Sheet 4 for Backwall Position Detail

- NOTES:**
1. Remove backfill and geotextile from hollow core of the top 3 courses of CMUs and all corner CMUs, insert #4 Bars, and fill with concrete.
  2. Strike CMU concrete fill flush with top of CMUs under bridge girders, slope to drain.
  3. On the top course of CMUs create a CIP coping a minimum of 3/4-inch thick.
  4. Provide Solid CMU Blocks behind riprap.
  5. Short term back slope ratio per OSHA Safety Regulations (29CFR, Part 1926, Subpart P, excavation). Shoring may be required if the short term back slope will be open more than 30 days or if the required short term back slope ratio specified cannot be obtained.
  6. Extend Integrated Approach layers past 1:1 Control Line as shown.
  7. Before constructing each wrapped geosynthetic layer cover exposed geosynthetic with 1 to 2 inches of aggregate backfill.
  8. Wall control drawings based on plumb wall facing. With the approval of the Engineer, segmental retaining wall unit facing blocks may be substituted for solid and hollow CMU facing blocks in accordance with Developmental Specification Section 549. Contractor's Specialty Engineer must submit shop drawings depicting revised RSF elevations for approval. If segmental retaining wall unit facing blocks require battered erection, Contractor's Specialty Engineer must submit shop drawings depicting revised bottom wall course locations for approval.

SDATES

LAST REVISION 06/15/23	DESCRIPTION:
---------------------------	--------------



GRS-IBS

INDEX NO. D6025	SHEET NO. 3 of 10
--------------------	----------------------

DETAILS

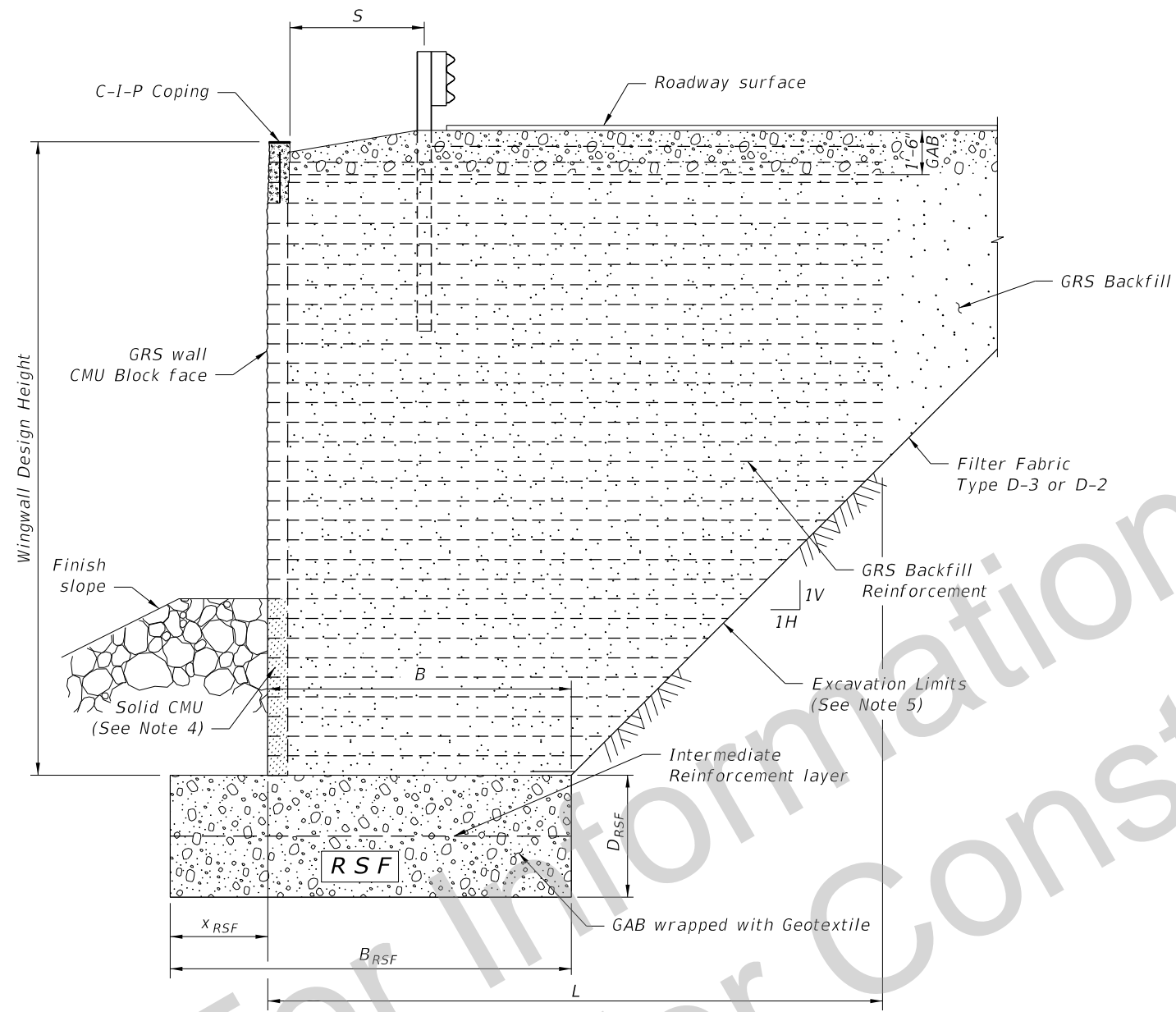

SECTION B-B

Cross References:  
See Sheet 3 for Notes.

SDATES STIMES

DETAILS

LAST REVISION	10/01/16	REVISION	DESCRIPTION:
---------------	----------	----------	--------------



DEVELOPMENTAL  
DESIGN STANDARDS

GRS-IBS

INDEX NO.  
D6025

SHEET NO.  
4 of 10

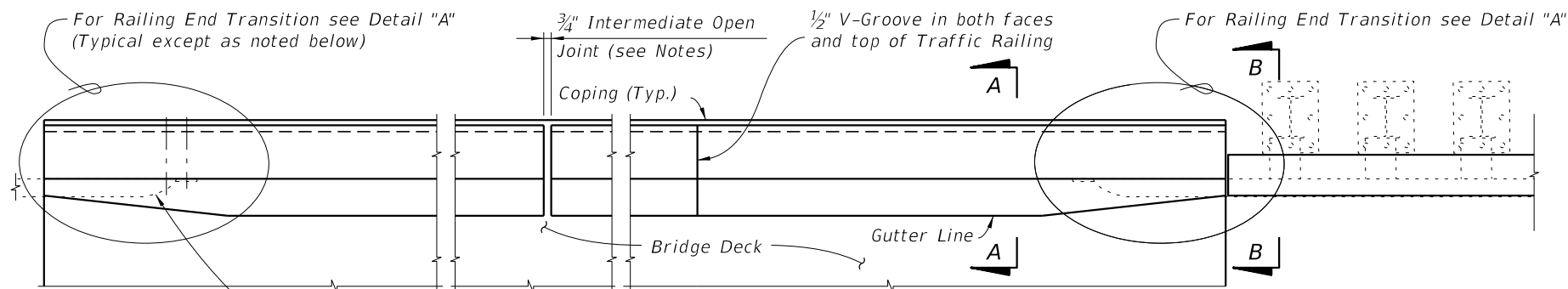

**PLAN**  
(Reinforcing Steel not shown for clarity)

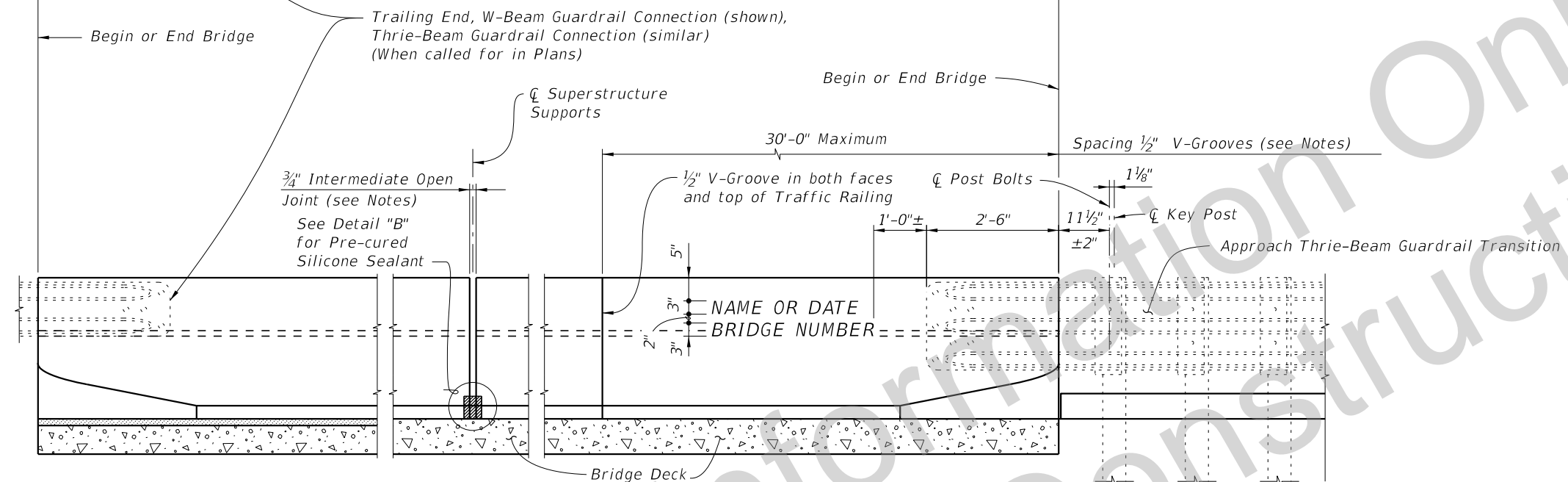

**ELEVATION OF INSIDE FACE OF RAILING**  
(Reinforcing Steel not shown for clarity)

REFLECTIVE RAILING MARKER SPACING	
Distance - Edge of Travel Lane to Face of Railing	Spacing (Ft.)
< 4'	40'
4' to 8'	80'
> than 8'	None Required

**CROSS REFERENCE:**  
For Section A-A, View B-B and Detail "A", see Sheet 6.  
For Detail "B", see Sheet 8.

**TRAFFIC RAILING NOTES**

This railing has been structurally evaluated to be equivalent or greater in strength to other safety shape railings which have been crash tested to NCHRP Report 350 TL-4 Criteria.

**CONCRETE AND REINFORCING STEEL :** See Structures Plans General Notes.

**GUARDRAIL :** For Guardrail connection details see Index Nos. D4XX and D4XX.

**SUPERELEVATED BRIDGES :** At the option of the Contractor the Traffic Railing on superelevated bridges may be constructed perpendicular to the roadway surface.

**PEDESTRIAN AND BICYCLE RAILING :** See Index Nos. 821 and 822 for Notes, Details and post spacings for Traffic Railings with Aluminum Pedestrian /Bicycle Bullet Railings.

**V-GROOVES :** Construct 1/2" V-Grooves plumb. Space V-Grooves equally between 3/4" Open Joints and/or Deck Joints.

**NAME, DATE AND BRIDGE NUMBER :** The Name and Bridge Number shall be placed on the Traffic Railing so as to be seen on the driver's right side when approaching the bridge. The Date shall be placed on the driver's left side when approaching the bridge. The Name shall be as shown in the General Notes in the Structures Plans. The Date shall be the year the bridge is completed. Black plastic letters and figures 3" in height may be used, as approved by the Engineer, in lieu of the letters and figures formed by 3/8" V-Grooves. V-Grooves shall be formed by preformed letters and figures.

**REFLECTIVE RAILING MARKERS :** Reflective Railing Markers shall meet Specification Section 993. Install markers on top of the Traffic Railing 2" from the face on the traffic side at the spacing shown in the table above. Reflector color (white or yellow) shall match the color of the near edgeline. The cost of the reflective markers shall be included in the Contract Unit Price for the Traffic Railing.

**JOINTS :** See Plans, Superstructure Sheets for actual dimensions and joint orientation. Provide open Railing Joints at Deck Expansion Joint locations matching the dimensions of the Deck Joint. For treatment of Railings on skewed bridges see Sheet No. 7. Provide 3/4" Intermediate Open Joints at Superstructure supports where slab is continuous.

**TRAFFIC RAILING DETAILS (32" F SHAPE)**

LAST REVISION	DESCRIPTION:
10/01/16	



**DEVELOPMENTAL DESIGN STANDARDS**

GRS-IBS

INDEX NO.  
**D6025**

SHEET NO.  
**5 of 10**

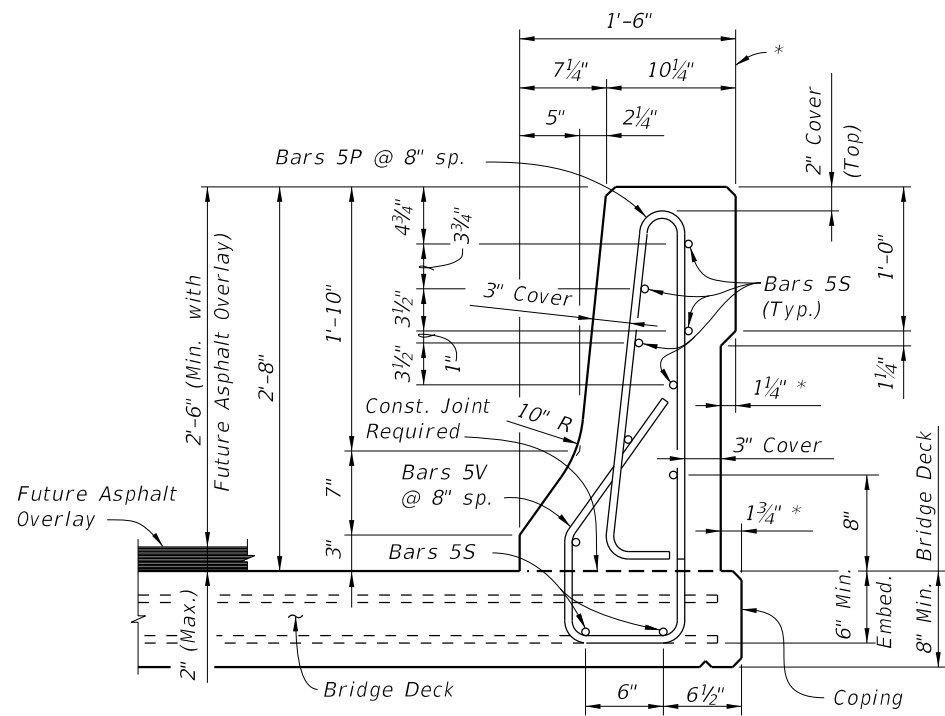

SECTION A-A  
TYPICAL SECTION THRU TRAFFIC RAILING

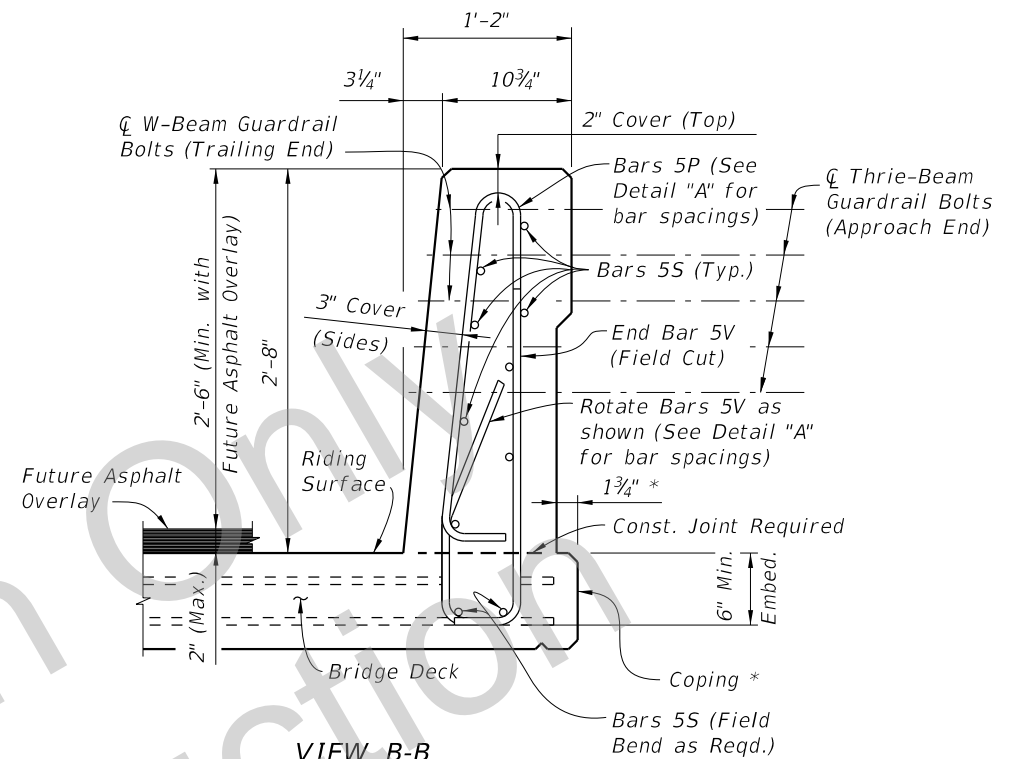

VIEW B-B

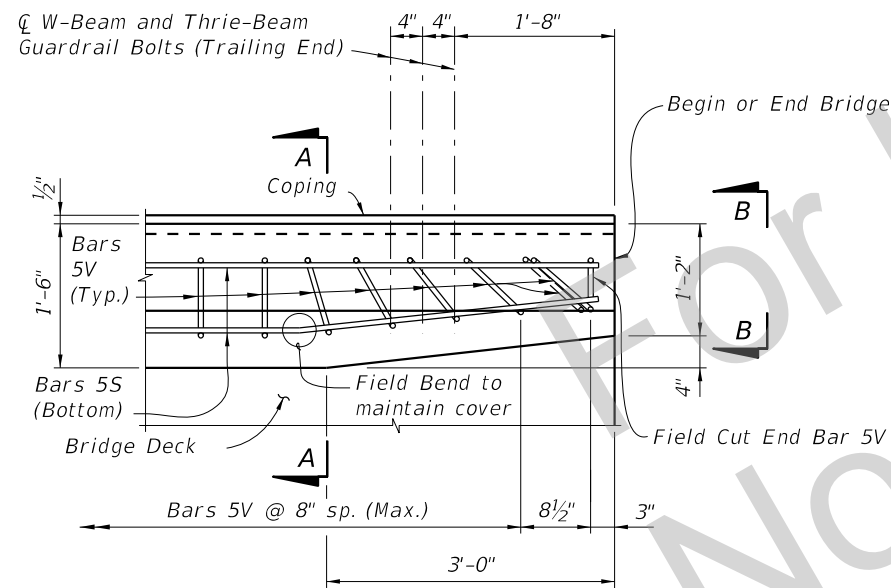

PLAN - Railing End Transition  
(Showing Bars 5V and 5S)

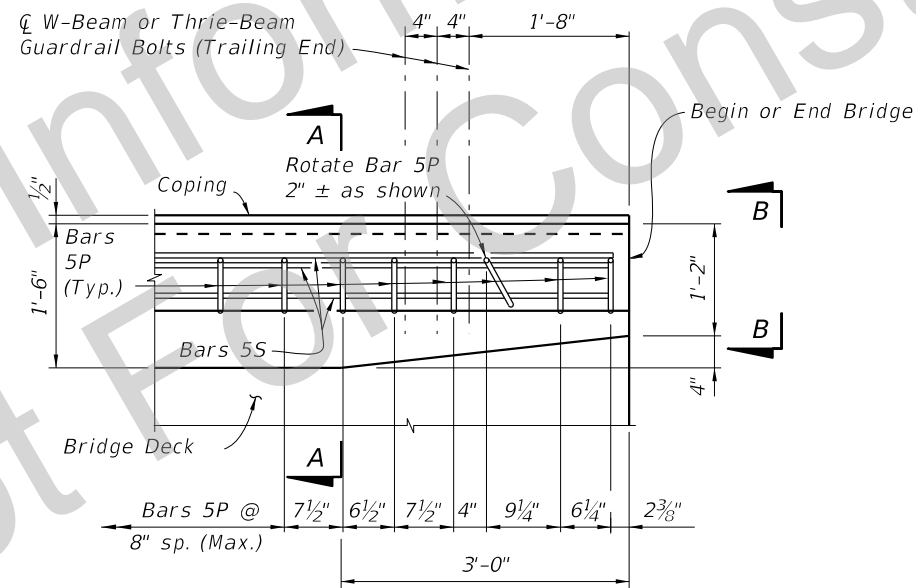

PLAN - Railing End Transition  
(Showing Bars 5P and 5S)

NOTES:

Rotate Bars 5V in Railing End Transition to maintain cover. Begin placing Railing Bars 5P and 5V at Begin or End Bridge to ensure correct placement of guardrail bolt holes. If required, adjustments to the bar spacing for Bars 5P and 5V shall be made away from Begin or End Bridge.

CROSS REFERENCE:

For locations of Section A-A and View B-B see Sheet 5.

DETAIL "A"

SDATES

LAST REVISION  
10/01/16

REVISION

DESCRIPTION:



DEVELOPMENTAL  
DESIGN STANDARDS

GRS-IBS

INDEX NO.  
D6025

SHEET NO.  
6 of 10

TRAFFIC RAILING DETAILS (32" F SHAPE)

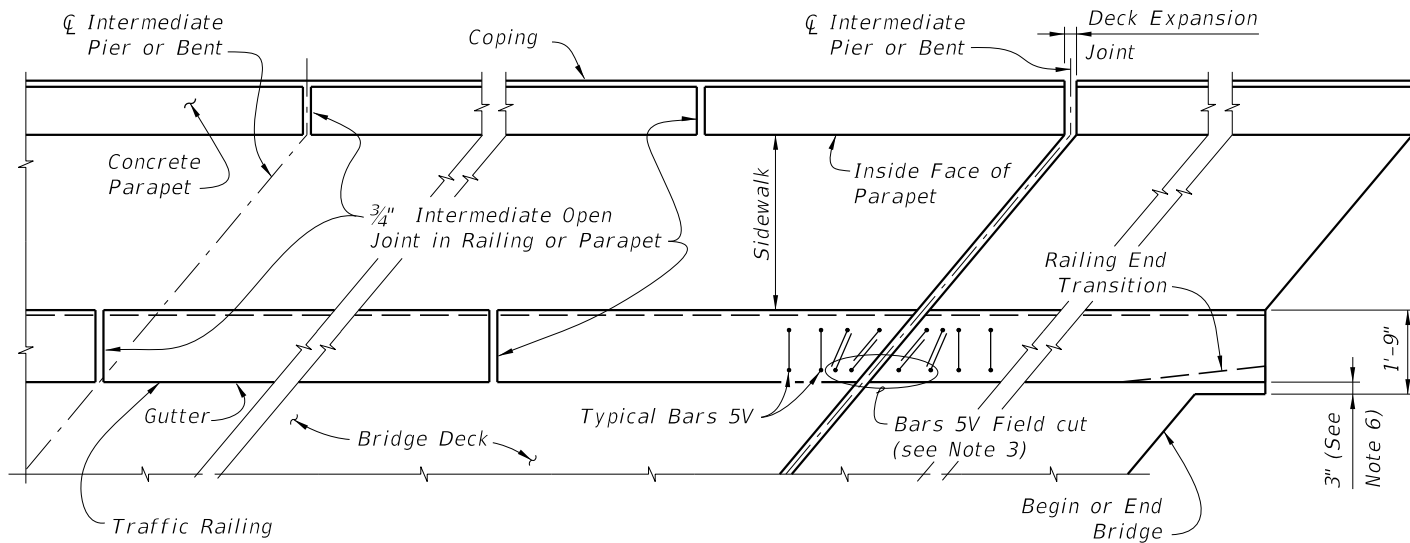

**PARTIAL PLAN VIEW OF SKEWED BRIDGE DECK WITH SIDEWALK, F SHAPE TRAFFIC RAILING AND PEDESTRIAN/BICYCLE RAILING  
INDEX NO. 820, 825 or 826, OTHER TRAFFIC RAILINGS SIMILAR**

**NOTES:**

- 1) Concrete Parapet reinforcement is not effected by skew angle, see Index No. 820 for details.
- 2) Parapet expansion joint shall match the deck expansion joint which shall be turned perpendicular or radial to the gutter line. See Structures Plans, Superstructure Sheets for details.
- 3) Traffic Railing reinforcement vertical Bars 5V & 5P may be shifted up to 1" (Max.) and rotated up to 10 degrees as required to allow proper placement. Bars 5V adjacent to expansion joints shall be field adjusted to maintain clearance and spacing, extra Bars 5V will be required. Bars 5V bottom horizontal portion shall be cut so as to maintain maximum bottom horizontal length of bar to each vertical leg being placed, the remainder of bar shall be discarded. Cut Bars 5V may be rotated to maintain clearance.
- 4) Railing ends at deck expansion joints shall follow the deck joint with allowance for joint movement. Expansion joint at the inside face of parapet shall be turned perpendicular or radial to this line. See Structures Plans, Superstructure Slab Sheets for details.
- 5) 3/4" Intermediate Open Joints and V-Grooves in railing and parapet shall be placed perpendicular or radial to the gutter line or inside face of parapet line. See Structures Plans, Superstructure Sheets for locations.
- 6) At begin or end Bridge extend deck at the railing ends 3" (gutter side or back face of railing as required) as shown to provide a base for casting of the railing.

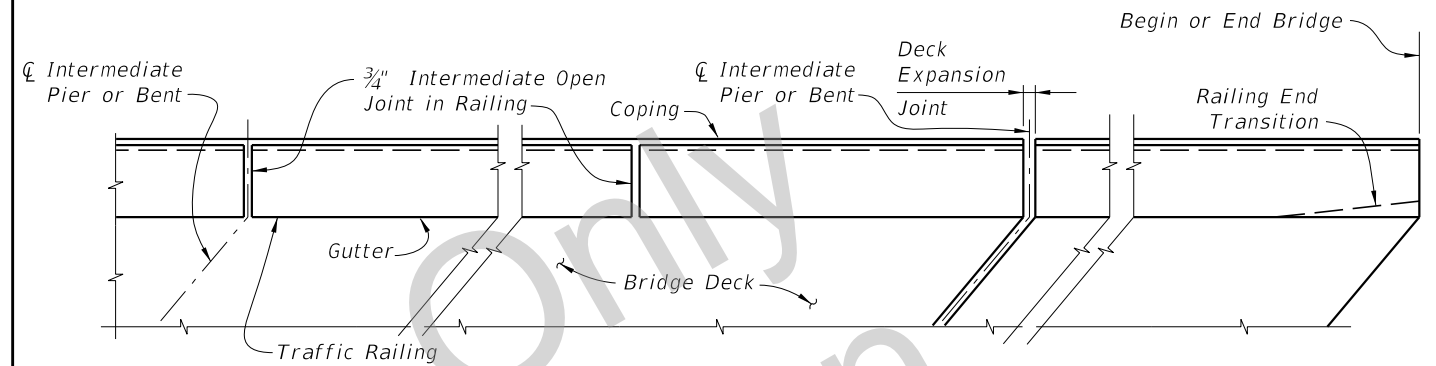

**PARTIAL PLAN VIEW OF SKEWED BRIDGE DECK**

**NOTES:**

- 1) Railing expansion joint shall match the deck expansion joint which shall be turned perpendicular or radial to the gutter line. See Structures Plans, Superstructure Sheets for details.
- 2) 3/4" Intermediate Open Joints and 1/2" V-Grooves in railing shall be placed perpendicular or radial to the gutter line. See Structures Plans, Superstructure and Approach Slab Sheets for locations.

**GENERAL NOTES:**

- 1) Work this Sheet with Traffic Railing, Pedestrian/Bicycle Railing, and Approach Slab Indexes as applicable.
- 2) Partial Plan Views shown are intended as guides only. See Structures Plans, Superstructure and Approach Slab Sheets for skew angles, joint orientation, dimensions and details.
- 3) Railings on Raised Sidewalks shall be treated similar to the Partial Plan View of Bridge Deck with Traffic Railing.
- 4) If Welded Wire Reinforcement is used in lieu of conventional reinforcement, placement of the WWR vertical elements shall be similar to those shown above. Clipping of horizontal elements to facilitate placement shall be minimized where possible. When clipping is required, supplement horizontal elements by lap splicing with deformed bars having an equivalent area of steel.

**TRAFFIC RAILING DETAILS (32" F SHAPE)**

LAST REVISION 10/01/16	DESCRIPTION:
---------------------------	--------------



**DEVELOPMENTAL  
DESIGN STANDARDS**

**GRS-IBS**

INDEX NO.  
**D6025**

SHEET NO.  
**7 of 10**

ALTERNATE REINFORCING STEEL (WELDED WIRE REINFORCEMENT) DETAILS

CONVENTIONAL REINFORCING STEEL BENDING DIAGRAMS

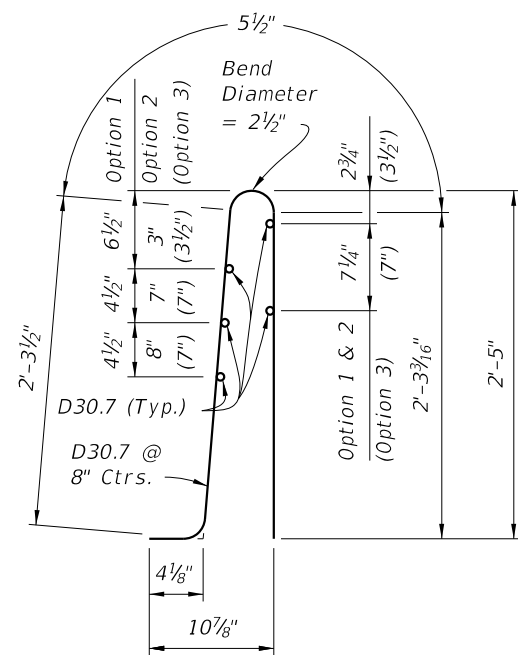

WWR Piece No. 2

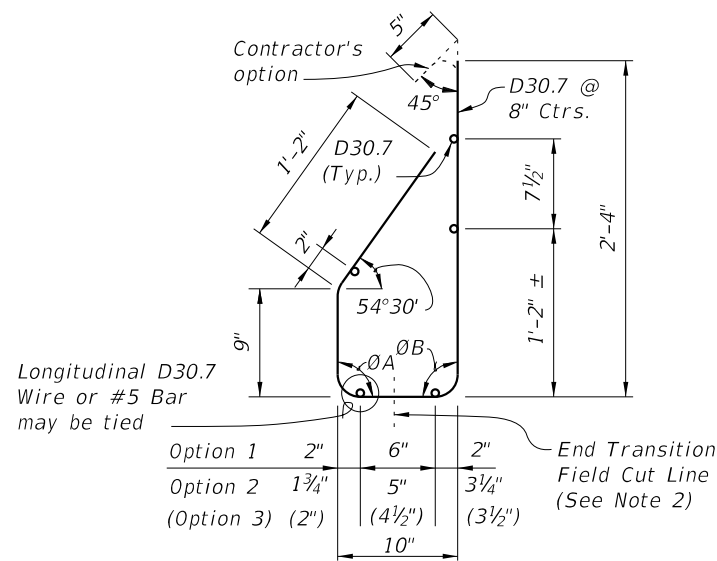

WWR Piece No. 1

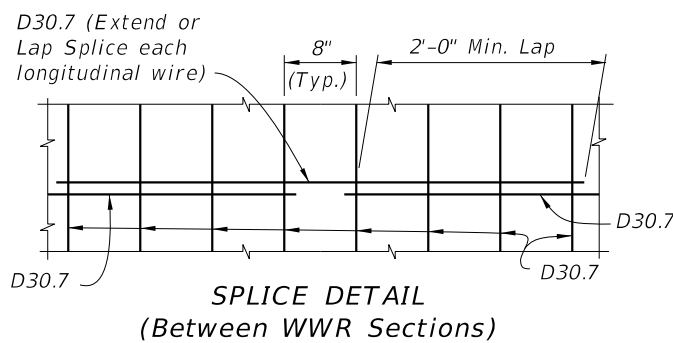

SPLICE DETAIL (Between WWR Sections)

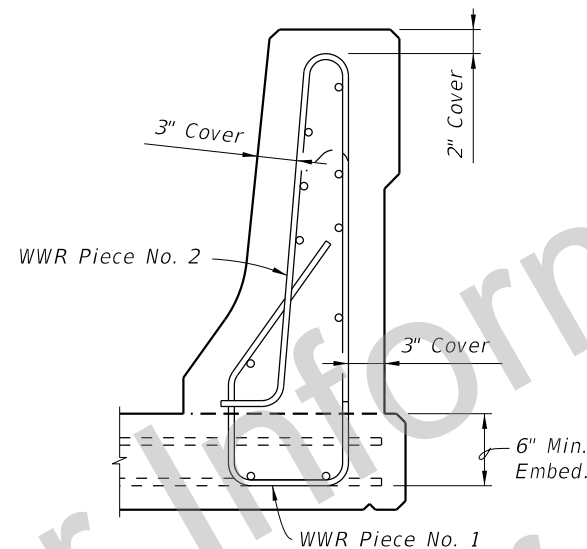

WWR Piece No. 1

WELDED WIRE REINFORCEMENT NOTES:

- At the option of the Contractor Welded Wire Reinforcement (WWR) may be utilized in lieu of all Bars 5P, 5S and 5V. WWR must consist of deformed wire meeting the requirements of Specification Section 931.
- WWR at Railing End Transition shall be field bent inward as required (Pieces 1 & 2) to maintain cover. The vertical wires (D30.7) in Piece 1 shall be cut as shown and the gutter side portion bent inward as required to allow placement.

ROADWAY CROSS-SLOPE	LOW GUTTER		HIGH GUTTER	
	ØA	ØB	ØA	ØB
0% to 2%	90°	90°	90°	90°
2% to 6%	93°	87°	87°	93°
6% to 10%	96°	84°	84°	96°

ØA and ØB shall be 90° if Contractor elects to place railing perpendicular to the deck and approach slabs.

BILL OF REINFORCING STEEL		
MARK	SIZE	LENGTH
P	5	5'-7"
S	5	As Req'd.
V	5	5'-1"

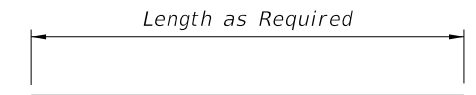

BAR 5S

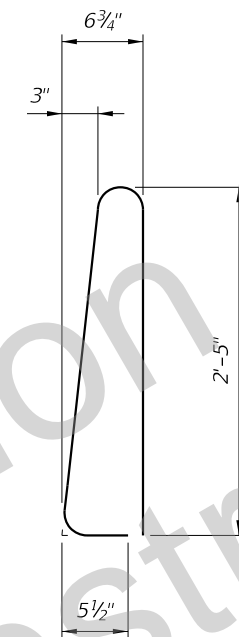

STIRRUP BAR 5P

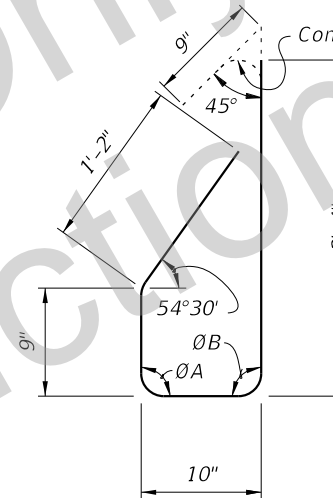

STIRRUP BAR 5V

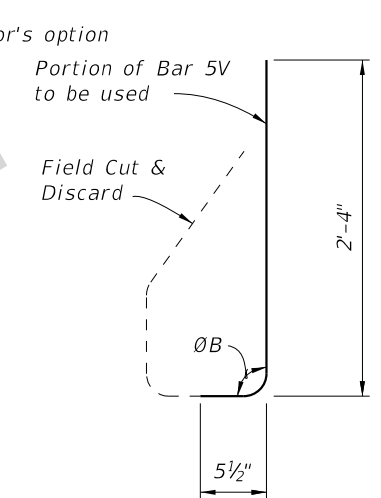

END STIRRUP BAR 5V To Be Field Cut (One Required per Railing End Transition)

REINFORCING STEEL NOTES:

- All bar dimensions in the bending diagrams are out to out.
- The 9" and the 2'-4" vertical dimensions shown for Bar 5V are based on a bridge deck without a raised sidewalk. If a raised sidewalk is to be provided, increase these dimensions to achieve a 6" minimum embedment into the bridge deck. See Structures Plans, Superstructure Sheets.
- All reinforcing steel at the open joints shall have a 2" minimum cover.
- Bars 5S may be continuous or spliced at the construction joints. Bar splices for Bars 5S shall be a minimum of 2'-0".

Pre-cured Silicone Sealant (4" wide)

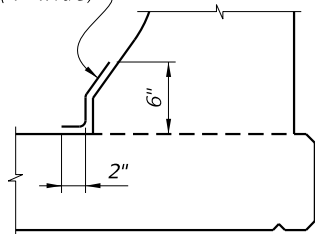

DETAIL "B" - SECTION AT INTERMEDIATE OPEN JOINT

INTERMEDIATE JOINT SEAL NOTES:

- At Intermediate Open Joints, seal the lower 6" portion of the open joint with Pre-cured Silicone Sealant in accordance with Specification Section 932.
- Apply sealant prior to any Class V finish coating and remove all curing compound and loose material from the surface prior to application of bonding agent.
- The cost of the Pre-cured Silicone Sealant shall be included in the Contract Unit Price for the Traffic Railing.

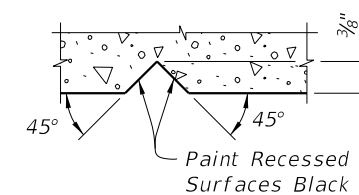

SECTION THRU RECESSED "V" GROOVE TO FORM INSCRIBED LETTERS AND FIGURES

ESTIMATED TRAFFIC RAILING QUANTITIES		
ITEM	UNIT	QUANTITY
Concrete	CY/LF	0.104
Reinforcing Steel	LB/LF	27.12

(The above quantities are based on a 2% deck cross slope; railing on low side of deck.)

TRAFFIC RAILING DETAILS (32" F SHAPE)

LAST REVISION 10/01/16

DESCRIPTION:

FDOT DEVELOPMENTAL DESIGN STANDARDS

GRS-IBS

INDEX NO. D6025

SHEET NO. 8 of 10



21"x12"x $\frac{5}{8}$ " Thrie-Beam Terminal Connector Plate (Back-Up Plate) and 8"x8"x $\frac{1}{4}$ " Special Galvanized Steel Filler Plate (See Design Standards Index 400)  $\frac{7}{8}$ " $\times$ 15" Long HS Hex Bolts (3 $\frac{1}{2}$ " Min. Thread Length) And Nuts (5 Req'd.) With 2 $\frac{1}{4}$ " OD Plain Round Washers Under Heads And Nuts

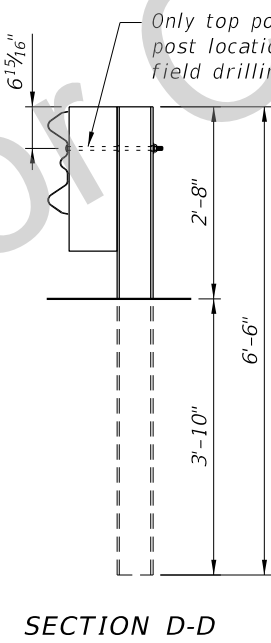
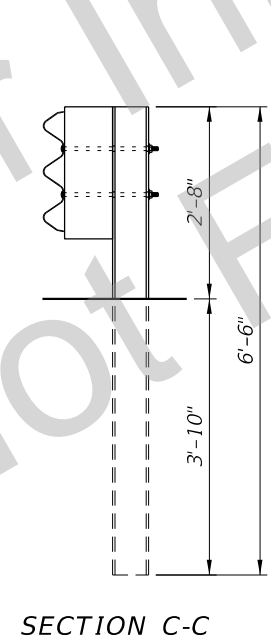
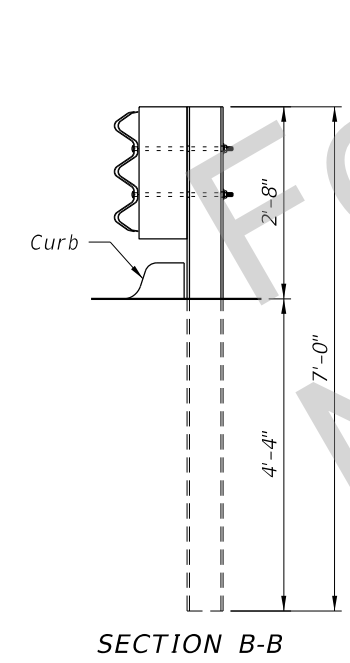
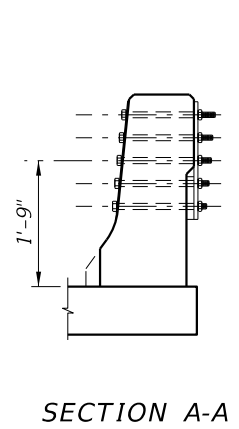
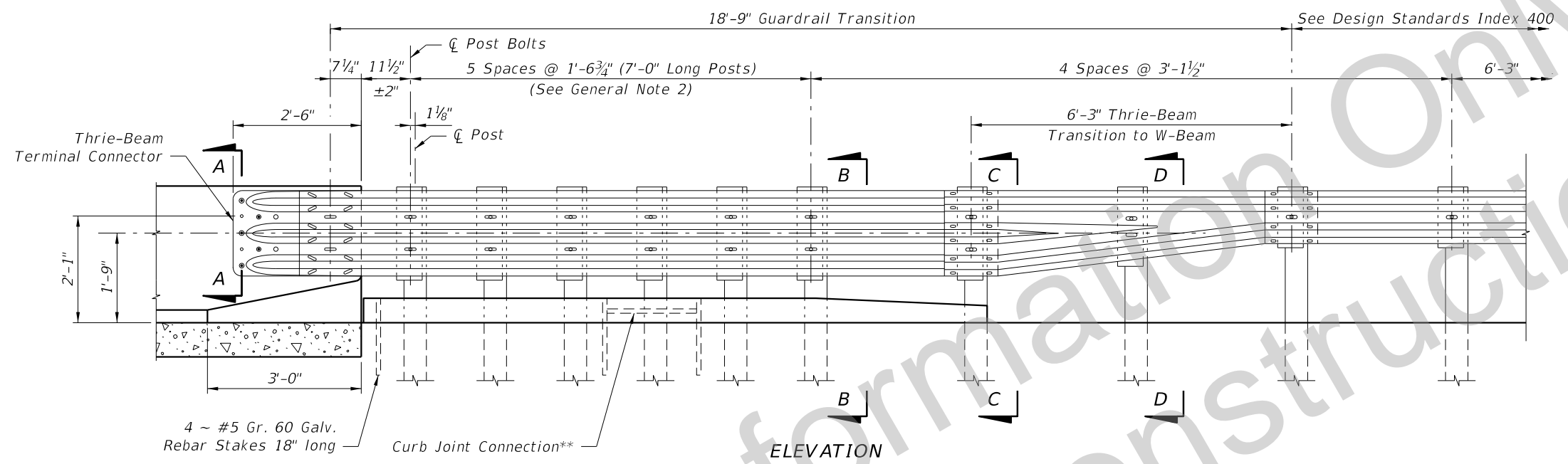
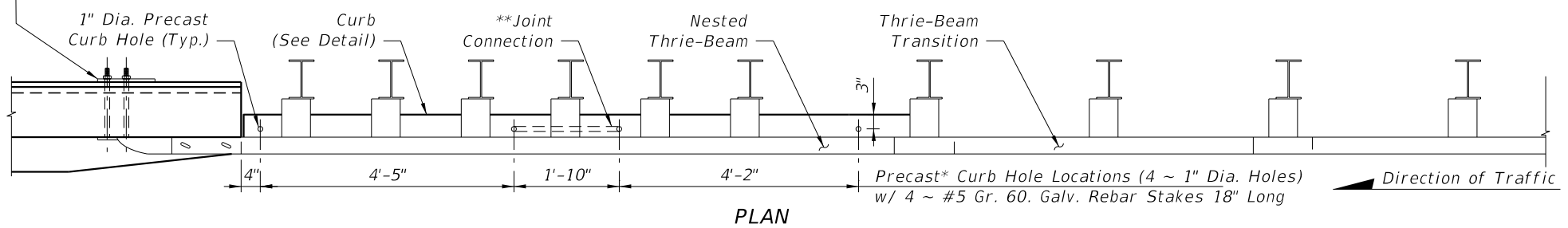

Only top post bolt required at this post location. Bottom bolt requires field drilling and is optional.

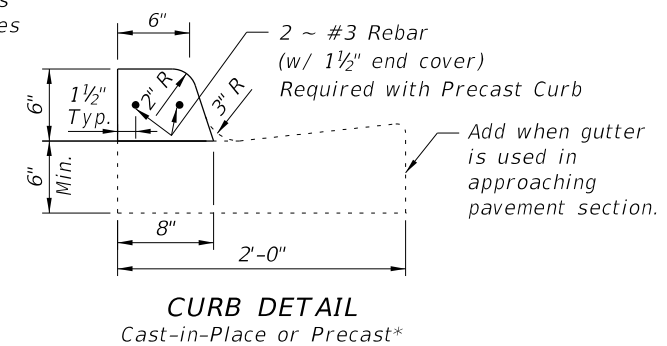

\* Precast Curb secured with 4 ~ #5 Gr. 60 Galv. Rebar Stakes 18" long. The 12'-2" section of curb may be cast in two sections:  
 Section 1 = 5'-8" long  
 Section 2 = 6'-6" long with the last 3'-6" of curb tapered to a 4" height.

\*\* Joint Connection is two 9" long 1" Dia. female ends connected with 1 ~ #5 Gr. 60 Galv. Rebar 18" long.

General Notes:

1. Concrete curb may be cast-in-place or precast as shown on this sheet. Concrete curb shall be continuous to the seventh post.
2. The post length shall be marked on all 7'-0" long posts by the Manufacturer. The mark shall be located within the top 1 ft. region of the post, at least  $\frac{5}{8}$ " in height, and visible after installation. Mark steel posts with a stencil before galvanizing.
3. Perform post holes as required by punching only. Performing post holes by drilling is not permitted.
4. Rail elements shall meet the requirements of Design Standards Index 400 except as modified herein.
5. Unless otherwise shown in the plans, transitions shall be placed with the block face in front of or directly above the curb face.
6. The (24) plate washers required at the terminal connector splice are 1 $\frac{3}{4}$ "x 3"x  $\frac{3}{16}$ " plate washers with a  $\frac{1}{16}$ " x 1" hole.

SDATES

THRIE-BEAM GUARDRAIL TRANSITION DETAILS

LAST REVISION 10/01/16	REVISION	DESCRIPTION:	<p>DEVELOPMENTAL DESIGN STANDARDS</p>	GRS-IBS	INDEX NO. D6025	SHEET NO. 9 of 10
---------------------------	----------	--------------	---------------------------------------	---------	--------------------	----------------------

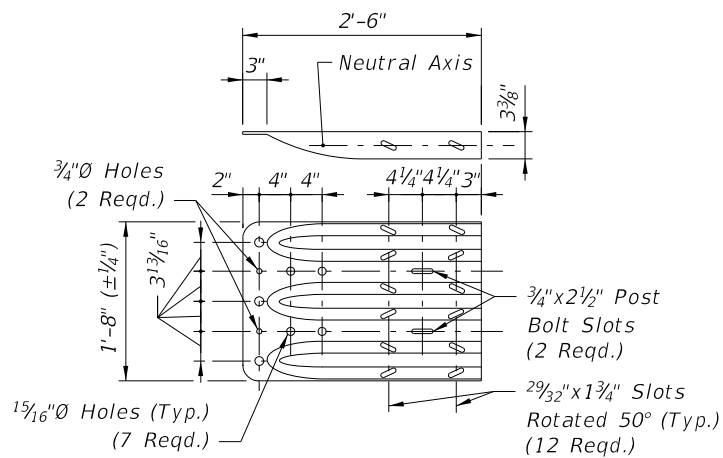

Note: 5/8"Ø steel washer required with splice bolts

**THRIE-BEAM TERMINAL CONNECTOR**  
(10 Gauge)

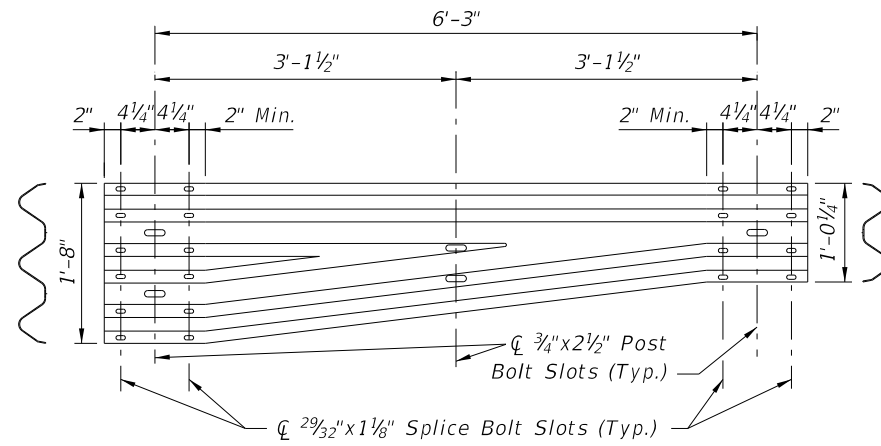

**W-THRIE BEAM TRANSITION SECTION**  
(10 Gauge)

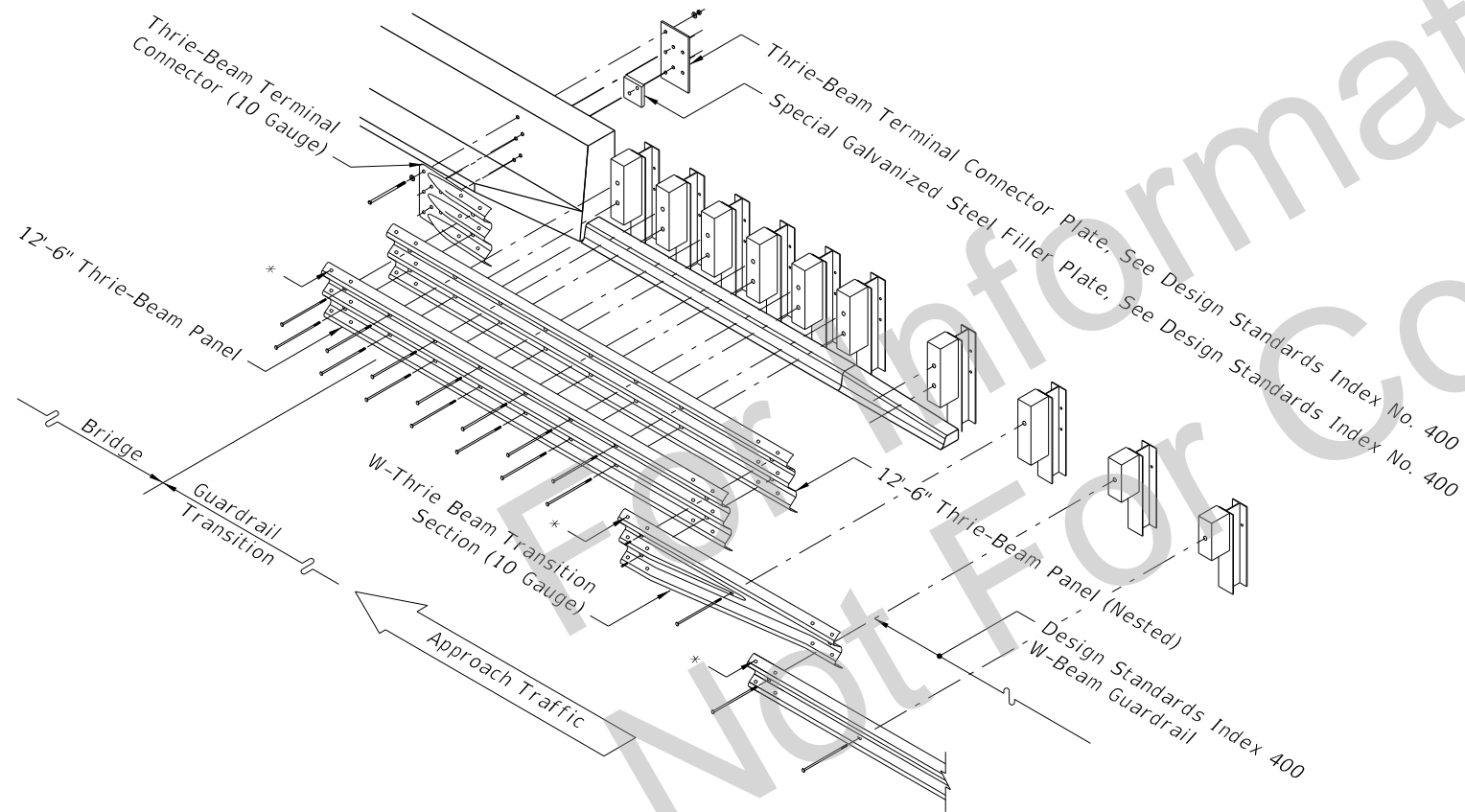

\* Splice Location: Thrie-Beam - 12 Guardrail Splice Bolts And Recessed Nuts  
W-Beam - 8 Guardrail Splice Bolts And Recessed Nuts

**PICTORAL VIEW OF GUARDRAIL TRANSITION AND CONNECTIONS**

SDATES STIMES

LAST REVISION 10/01/16	DESCRIPTION:
---------------------------	--------------



**DEVELOPMENTAL  
DESIGN STANDARDS**

GRS-IBS

INDEX NO.  
**D6025**

SHEET NO.  
**10 of 10**

THRIE-BEAM GUARDRAIL TRANSITION DETAILS