

GRAVITY WALL (Option B) NOTES

1. Work this Index with Specification Section 548, except payment shall be per Note 7.
2. Use blocks with a maximum batter from plumb of 1:12 or that meet the horizontal control shown in the Plans (whichever is more restrictive).
3. Place blocks and soil reinforcement (when required) in accordance with the manufacturer's instructions and these drawings.
4. Concrete for wall cap shall be Class NS per Section 347. Concrete for Scheme 3 Junction Slab and Traffic Railing shall be Class II per Section 346 unless otherwise specified in the Plans.
5. Drainage Layer:
 - a. For Segmental Block Walls provide a continuous one foot thick drainage layer of clean gravel or crushed rock. For Modular Block Walls provide an Edgedrain Concrete (Draincrete) drainage layer meeting the requirements of Section 446. Wrap the drainage layers as shown with Type D-3 Geotextile Filter Fabric meeting the requirements of Section 985.
 - b. Use 3" NPS (Schedule 40) PVC pipe for Weep Holes spaced at 30 feet max.
 - c. For walls 2 feet and taller, provide an Underdrain and Weep Holes as shown, meeting requirements of Section 948.
6. Provide Shop Drawings to the Engineer for approval with proposed block wall system, soil reinforcement, filter fabric, step locations in leveling pad, weep hole locations and top of wall elevations at 25 ft. max. spacing.
7. Cost of all materials and labor to construct the Gravity Block Wall including: reinforcing steel, concrete cap, edgedrain concrete, blocks, soil reinforcement, backfill, filter fabric, drain pipes, drain pipes and drainage layer to be included in the Contract Unit Price for Concrete Class NS, Gravity Wall.

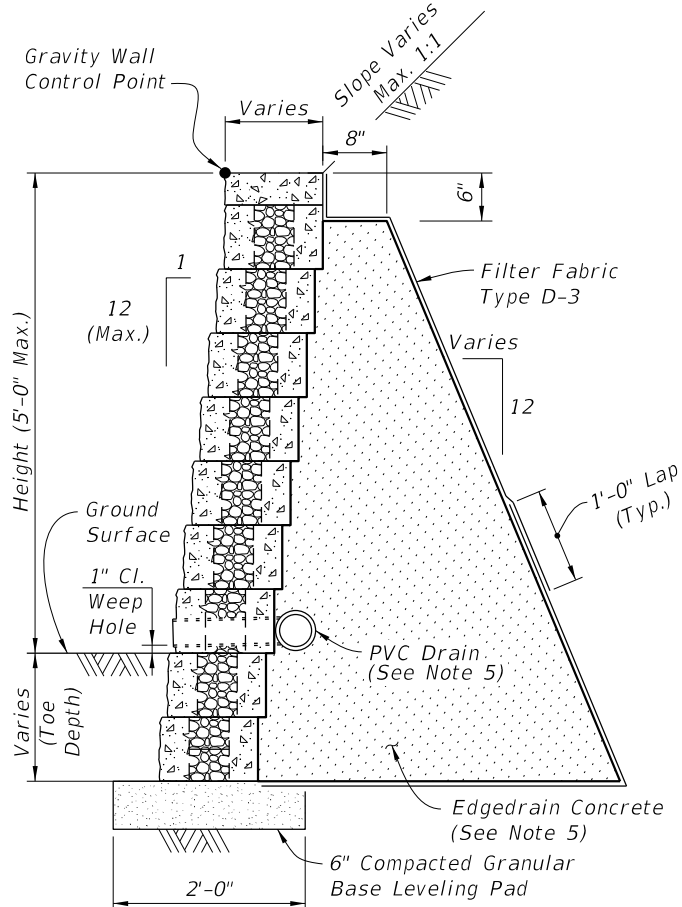

TYPICAL SECTION MODULAR BLOCK WALL (OPTION B1)
(Battered Wall Shown, Plumb Wall Similar)

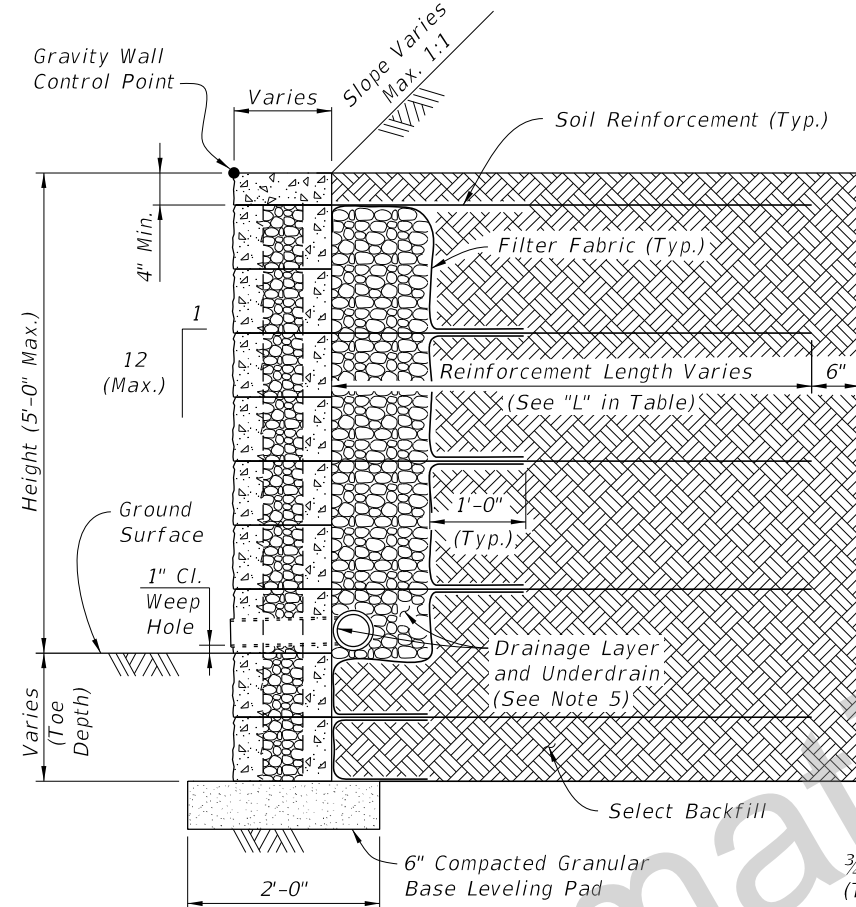

TYPICAL SECTION REINFORCED SEGMENTAL BLOCK WALL (OPTION B2)
(Plumb Wall Shown, Battered Wall Similar)

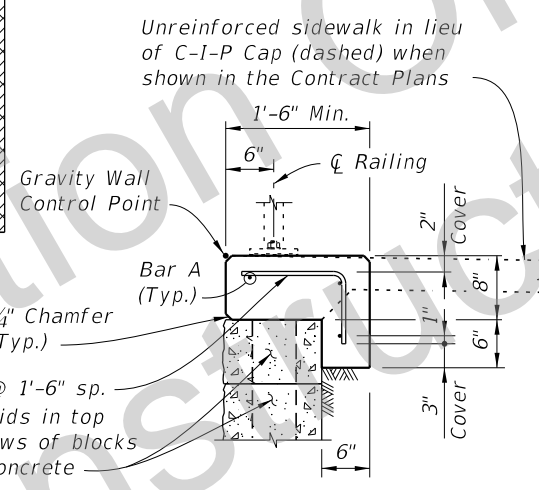

C-I-P CAP DETAIL (For Pedestrian Railing or Guiderail Attachment)

MINIMUM DESIGN PARAMETERS (OPTION B)					
HEIGHT (FT.)	LENGTH OF SOIL REINF. (L)			MAX. VERTICAL SPACING	UNDER-DRAIN REQD.
	SCHEME 1	SCHEME 2	SCHEME 3		
1'	6'	6'	8'	1'-4"	No
2'	6'	6'	8'	1'-4"	Yes
3'	6'	6'	8'	1'-4"	Yes
4'	6'	6'	8'	1'-4"	Yes
5'	6'	6'	8'	1'-4"	Yes

DESIGN PARAMETER NOTES:

1. Select Backfill material has the following properties:
 - Soil Friction Angle = 30° (minimum)
 - Moist Density = 105 psf (minimum)
2. Soil Reinforcement:
 - Ultimate Tensile Strength = 3,500 lb/ft

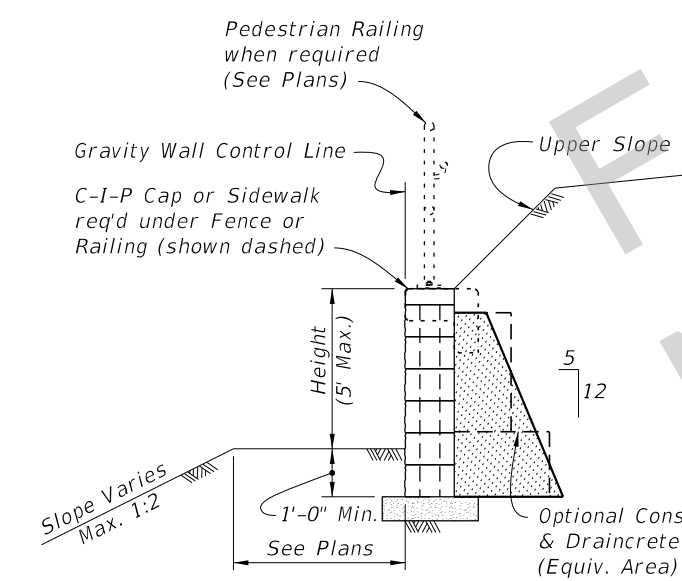
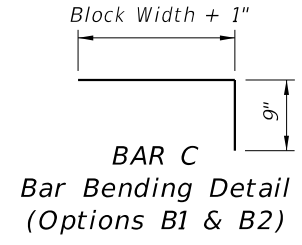

SCHEME 1 (No Traffic Loading Effects & Upper Slopes ≤ 1:1½)
Option B1 shown, Option B2 similar

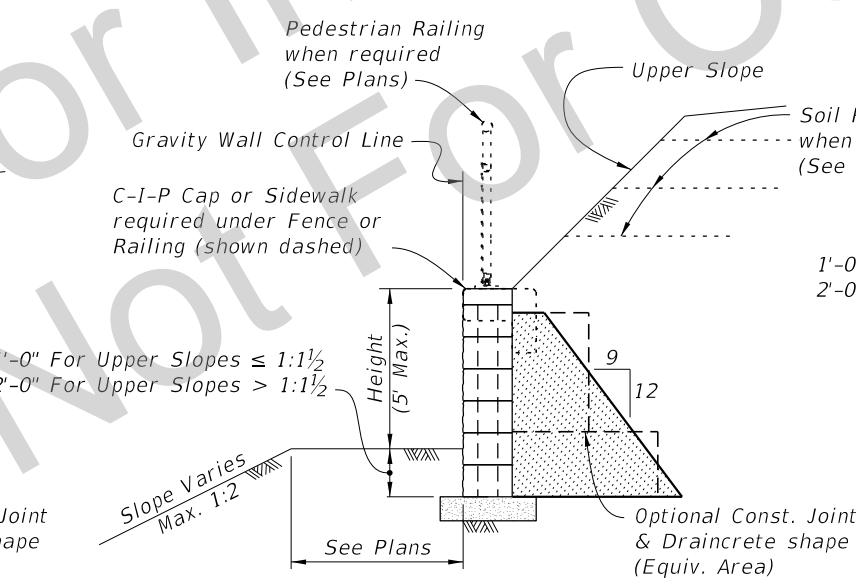

SCHEME 2 (With Traffic Loading or Upper Slopes > 1:1½)
Option B1 shown, Option B2 similar

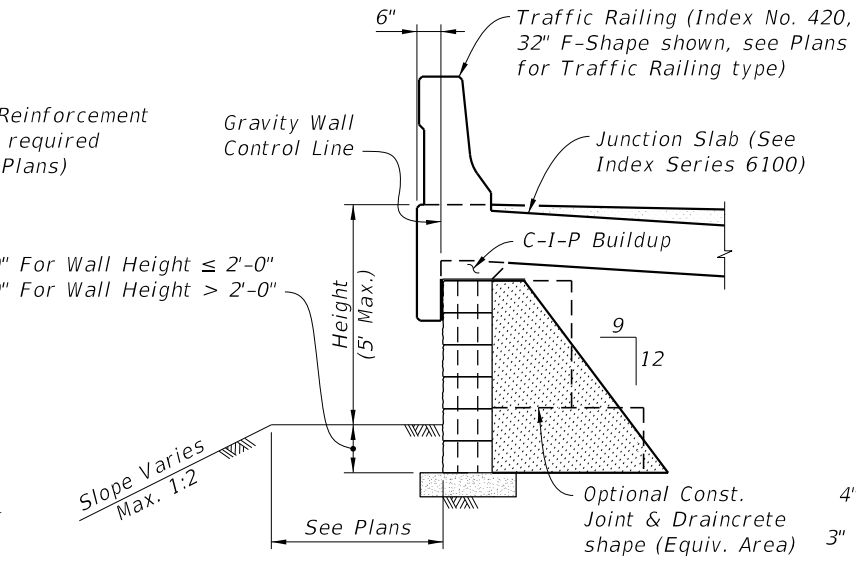

SCHEME 3 (With Traffic Railing)
Option B1 shown, Option B2 similar

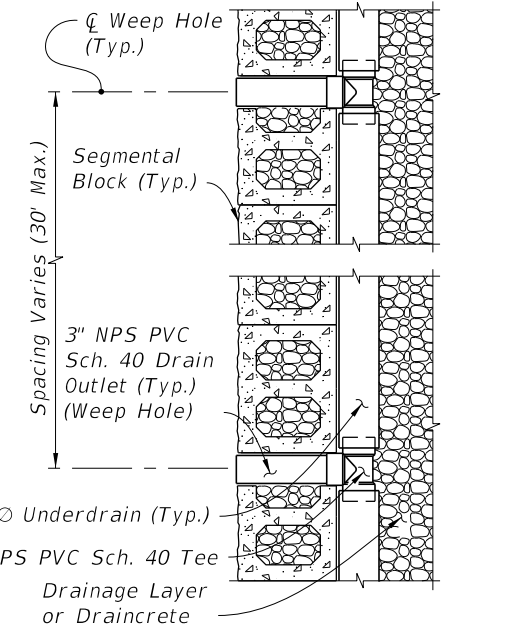

UNDERDRAIN DETAIL (PLAN VIEW)

3/22/2017 1:54:00 PM