

GENERAL NOTES:

U.S. COAST GUARD NOTIFICATION: Notify the local office of the U.S. Coast Guard at least 30 days prior to beginning of construction of the Fender System.

14" SQUARE PRESTRESSED CONCRETE PILES - Provide 14" Square Prestressed Concrete Piles of sufficient length to achieve a minimum embedment of 20' into soil having a blow count greater than or equal to 6 ( $N \geq 6$ ). Pile splices and build-ups are not permitted. Use only 14" Square Prestressed Concrete Piles with 8 - 1/2" diameter Low Relaxation Strands fabricated in accordance with Index No. 20614.

PLASTIC LUMBER AND STRUCTURAL COMPOSITE LUMBER WALES: Provide only Plastic Lumber (Thermoplastic Structural Shapes) and Structural Composite Lumber (Reinforced Thermoplastic Structural Shapes) Wales in accordance with Specification Section 973. Wales shall be continuous and spliced only at locations shown on the plans.

PLASTIC LUMBER DECKING FOR CATWALKS: Provide Plastic Lumber decking for catwalks when called for in the Plans in accordance with Specification Section 973.

Install Plastic Lumber Decking according to manufacturer's recommendations using stainless steel #10 x 3" (minimum) deck screws.

FIBERGLASS OPEN GRATING FOR CATWALKS: Provide Fiberglass Open Grating for catwalks when called for in the Plans. Fiberglass Open Grating shall be a heavy duty design suitable for exterior installations. Maximum gap opening on the walkway surface shall be 1 1/2". Design live loads and deflections shall be a 50 psf uniformly distributed load with a maximum deflection of 3/8" or L/120 at the center of a simple span and a concentrated load of 250 pounds with a maximum deflection of 1/4" at the center of a simple span. Color of Fiberglass Open Grating shall be gray or black.

Install Fiberglass Open Grating according to manufacturer's recommendations using stainless steel hardware, screws, bolts, nuts and washers. Attach Fiberglass Open Grating to Wales and Deck Supports at a 2'-0" maximum spacing so as to resist pedestrian live loads and uplift forces from wind, buoyancy and wave action.

CLEARANCE GAUGE AND LIGHT: Clearance Gauge to be furnished and installed by the Contractor. Clearance Gauge width and numeral height is dependant on visibility distance. The required visibility distance shall be determined by the United States Coast Guard District Commander. Provide and install Clearance Gauge Light in accordance with Specification Section 510 and Index No. 21220.

NAVIGATION LIGHTS: Provide and install Navigation Lights in accordance with Specification Section 510, Index No. 21220 and/or project specific details. Provide and maintain Temporary Navigation Lights during construction until permanent Navigation Lights are operational.

BOLTS, THREADED BARS, NUTS, SCREWS AND WASHERS: Furnish stainless steel Bolts in accordance with ASTM F593 Type 316. Furnish stainless steel Threaded Bars in accordance with ASTM A193 Grade B8M. Furnish stainless steel Nuts in accordance with ASTM F594 Type 316. Furnish stainless steel Screws in accordance with ASTM F593 Type 305. Furnish stainless steel Washers compatible with Bolts, Threaded Rods and Nuts under heads and nuts. Torque Nuts on 1" diameter Bolts and Threaded Bars to 150 lb-ft. Keep threads on Bolts, Threaded Bars and Nuts free from dirt, coarse grime and sand to prevent galling and seizing during tightening.

SPLICE PLATES: Furnish Splice Plates in accordance with ASTM A240 Type 316.

WIRE ROPE: Provide wire rope meeting one of the following requirements:

1. 1/2" diameter 6x19, 6x25 or 6x37 class IWRC Type 316 stainless steel wire rope with a minimum breaking strength of 18,000 lbs.
2. 1/2" diameter 6x19 galvanized wire rope with ultraviolet ray resistant polypropylene impregnation having an outside diameter of 5/8" with a minimum breaking strength of 22,000 lbs. Protect all ends with heat shrinkable end caps compatible with the rope's polypropylene that provide an effective water-tight seal.

FENDER SYSTEM ENERGY CAPACITY:  
Energy Capacity = 38 ft-k

GENERAL NOTES

10/26/2016 9:19:14 AM

LAST REVISION 07/01/14	REVISION	DESCRIPTION:	 FY 2017-18 DESIGN STANDARDS	FENDER SYSTEM - PRESTRESSED CONCRETE PILES	INDEX NO. 21930	SHEET NO. 1 of 7
---------------------------	----------	--------------	--	---	--------------------	---------------------

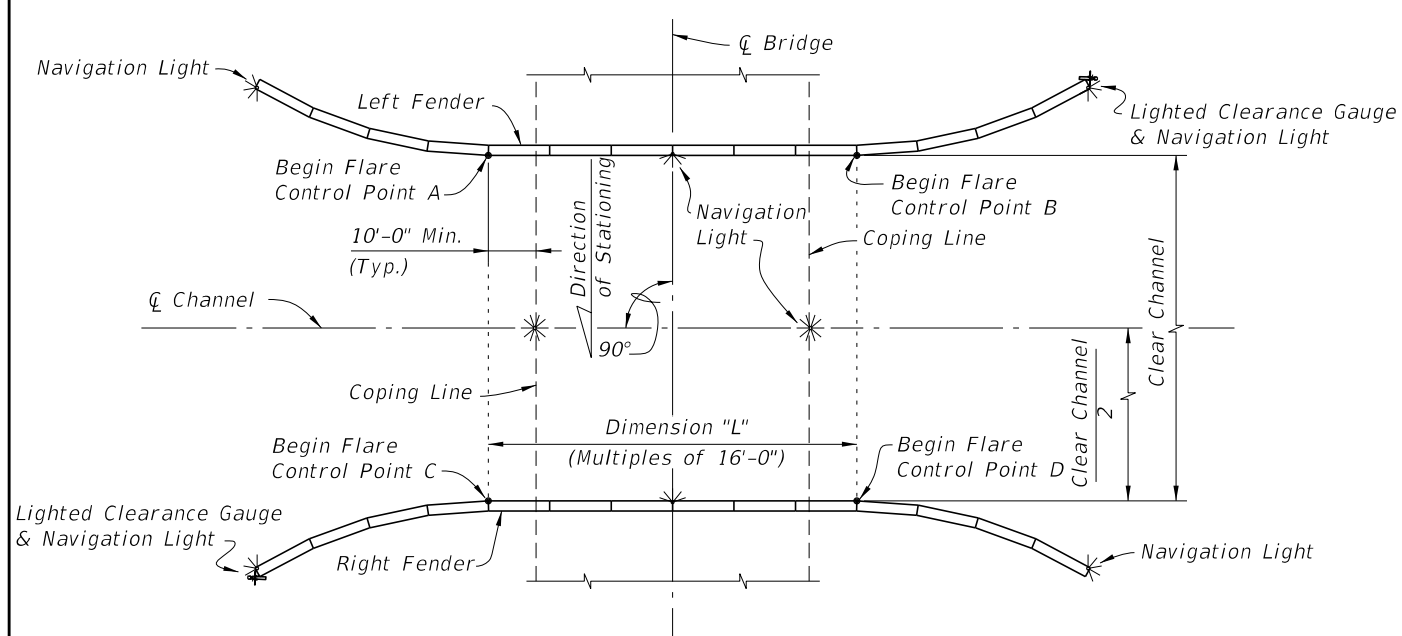

**SCHEMATIC OF FENDER SYSTEM SHOWING TREATMENT OF SINGLE FIXED BRIDGE WITH NONSKEWED CHANNEL**

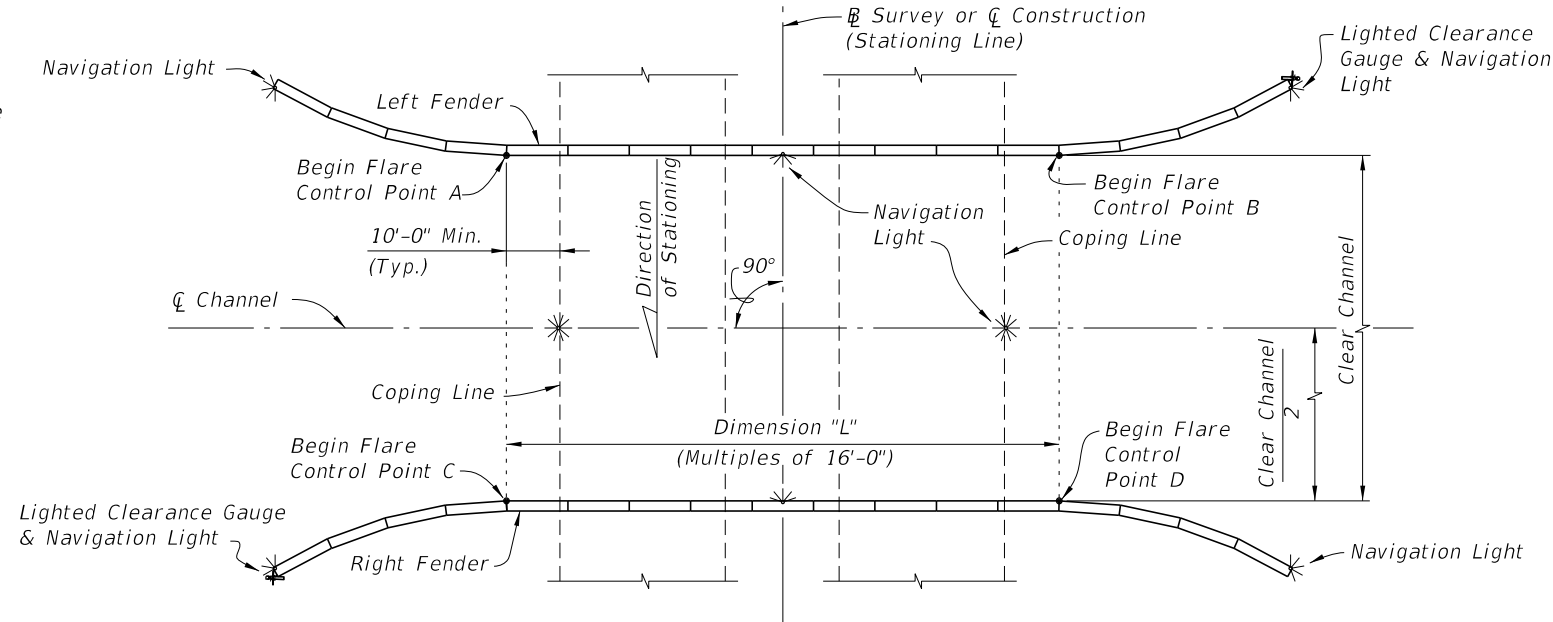

**SCHEMATIC OF FENDER SYSTEM SHOWING TREATMENT OF DUAL FIXED BRIDGES WITH NONSKEWED CHANNEL (PARALLEL DUAL FIXED BRIDGES SHOWN, NONPARALLEL DUAL FIXED BRIDGES SIMILAR)**

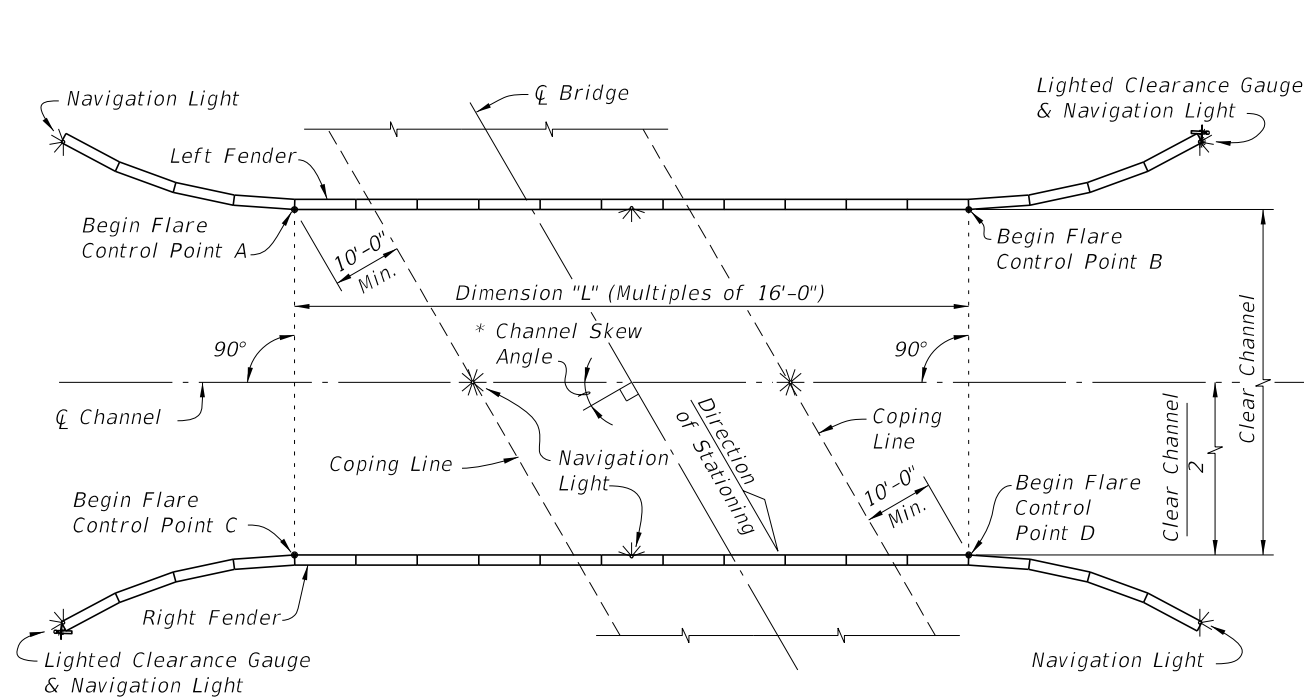

**SCHEMATIC OF FENDER SYSTEM SHOWING TREATMENT OF SINGLE FIXED BRIDGE WITH SKEWED CHANNEL**

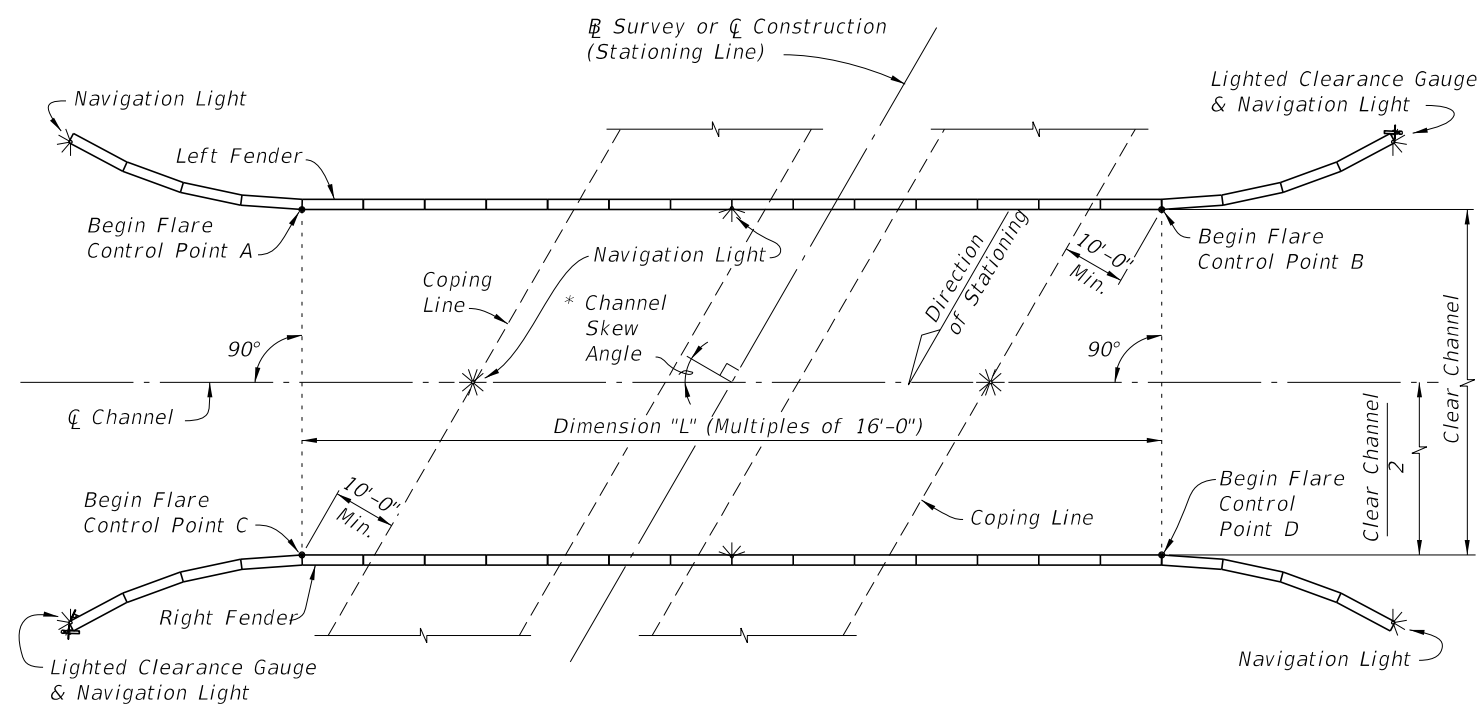

**SCHEMATIC OF FENDER SYSTEM SHOWING TREATMENT OF DUAL FIXED BRIDGES WITH SKEWED CHANNEL (PARALLEL DUAL FIXED BRIDGES SHOWN, NONPARALLEL DUAL FIXED BRIDGES SIMILAR)**

\* See Structures Plans, Plan and Elevation and Foundation Layout Sheets for magnitude and orientation of Channel Skew Angle.

**CROSS REFERENCES:**  
 For Stations and Offsets of referenced Control Points A, B, C and D,  
 Dimension "L" and Clear Channel Width see Fender System Table  
 of Variables in Structures Plans.  
 For Navigation Light Details see Design Standards Index 21220.

LAYOUT GEOMETRY

10/26/2016 9:19:17 AM

LAST REVISION 07/01/11	REVISION	DESCRIPTION:	 <b>FY 2017-18 DESIGN STANDARDS</b>	<b>FENDER SYSTEM - PRESTRESSED CONCRETE PILES</b>	INDEX NO. <b>21930</b>	SHEET NO. <b>2 of 7</b>
---------------------------	----------	--------------	--	---	---------------------------	----------------------------

**CROSS REFERENCES:**

For Sections A-A and B-B see Sheet 4.

For View F-F see Sheet 5.

**NOTE:**

Plastic Lumber and Composite Lumber Dimensions shown are based on Nominal Lumber Dimensions and may vary depending on Actual Lumber Dimension.

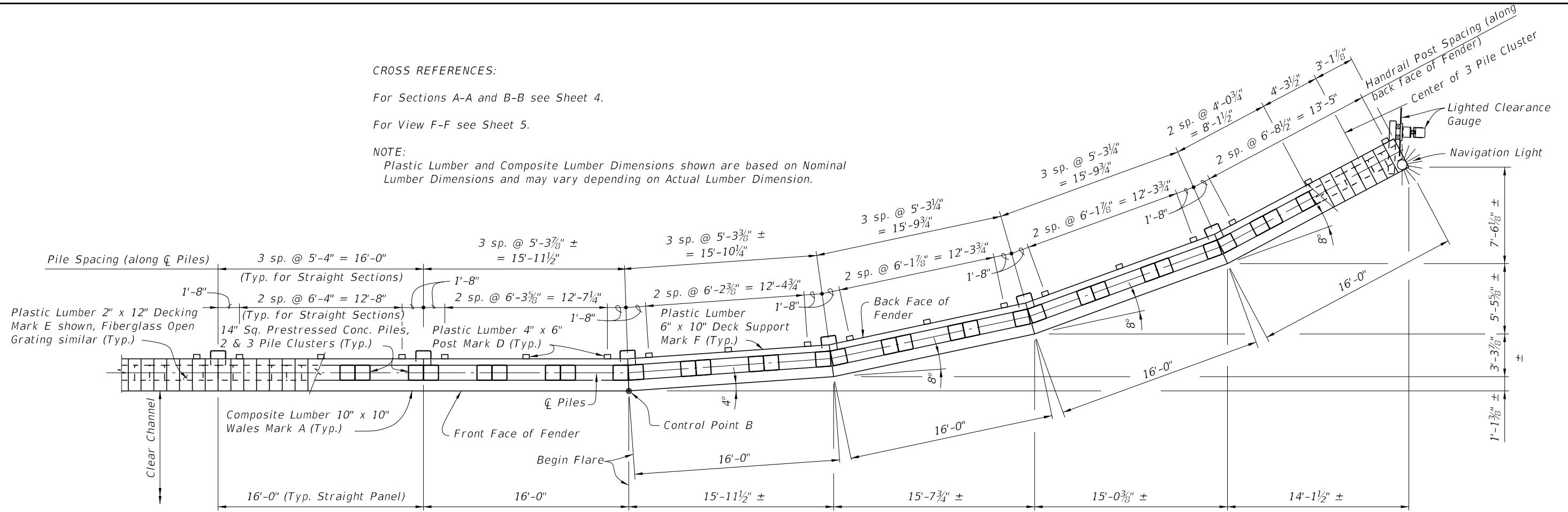

**PARTIAL PLAN VIEW (TYPICAL FLARE)**  
 (FLARE AT CONTROL POINT B SHOWN, CONTROL POINTS A, C & D SIMILAR)  
 (HANDRAIL NOT SHOWN FOR CLARITY)

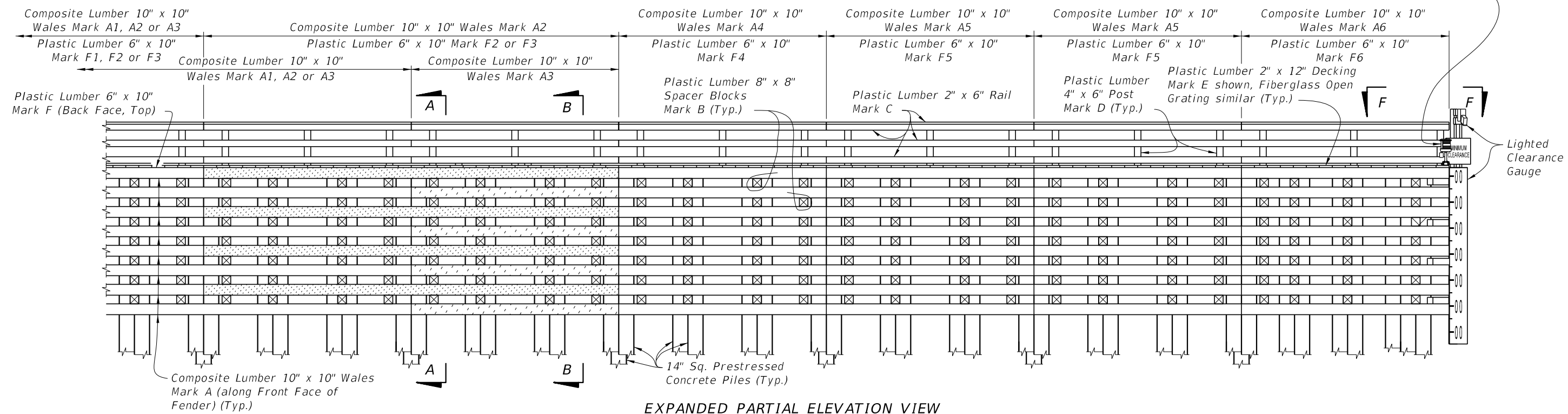

**EXPANDED PARTIAL ELEVATION VIEW**

10/26/2016 9:19:19 AM

LAST REVISION 01/01/12	DESCRIPTION:	 <b>FY 2017-18 DESIGN STANDARDS</b>	<b>FENDER SYSTEM - PRESTRESSED CONCRETE PILES</b>	INDEX NO. 21930	SHEET NO. 3 of 7
---------------------------	--------------	---	---	--------------------	---------------------

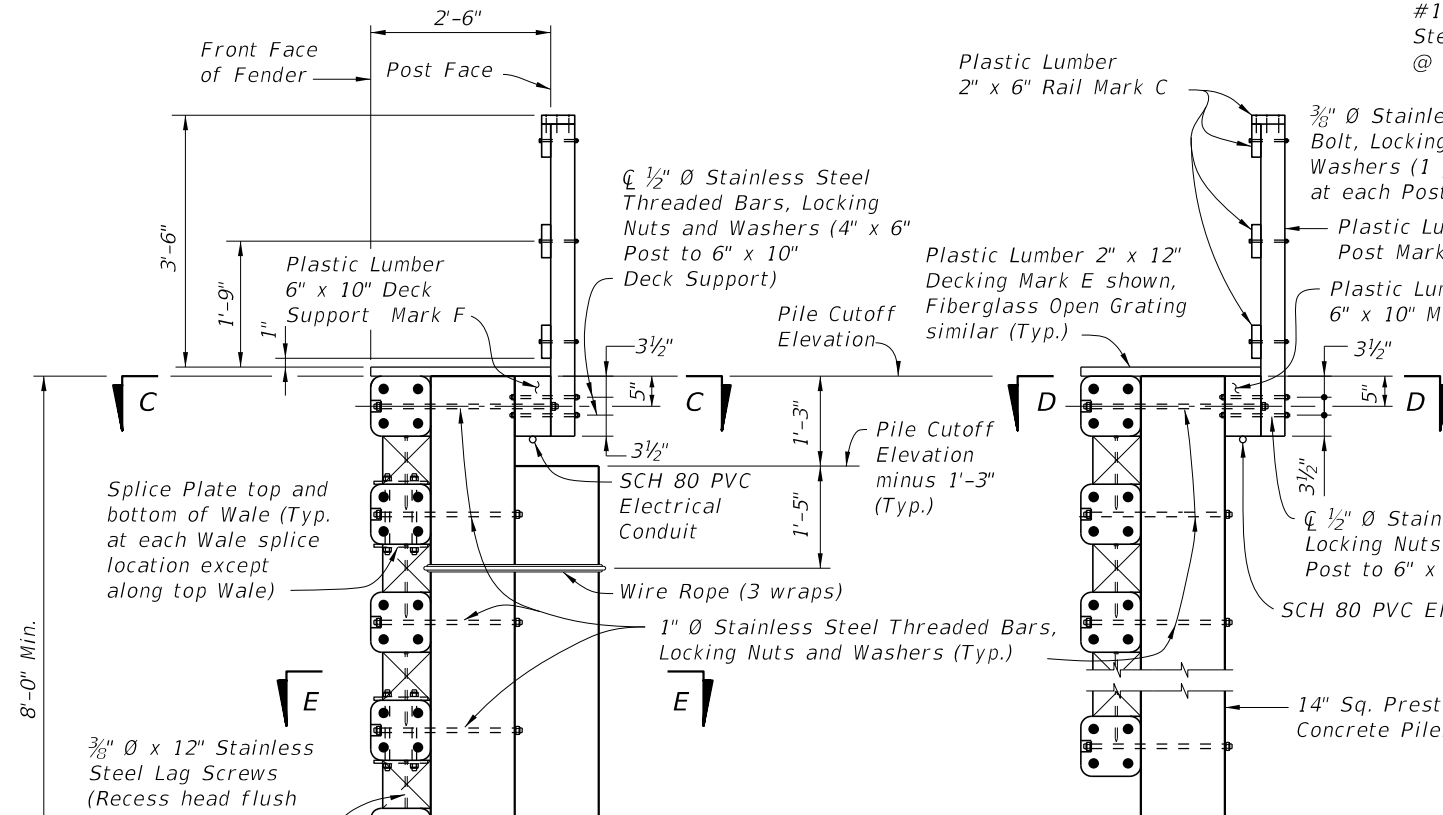

SECTION A-A

DETAIL "B" (SHOWING THREADED BAR LOCATION/RELATIONSHIP TO PILE PRESTRESSING STRANDS)

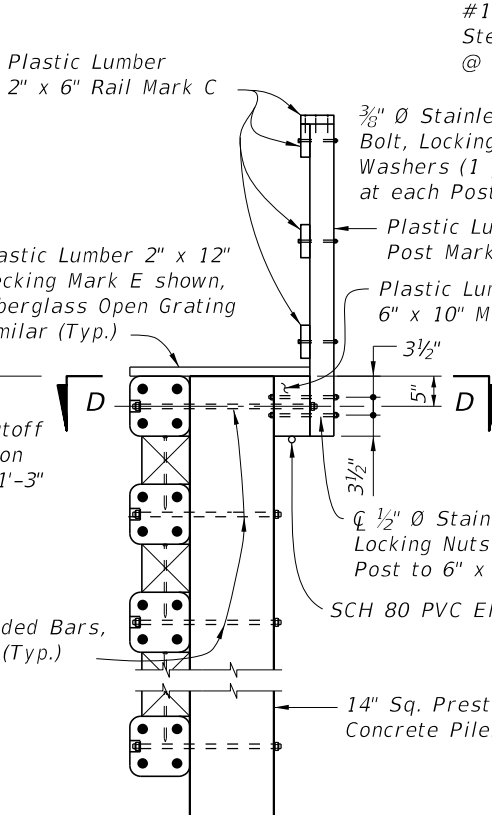
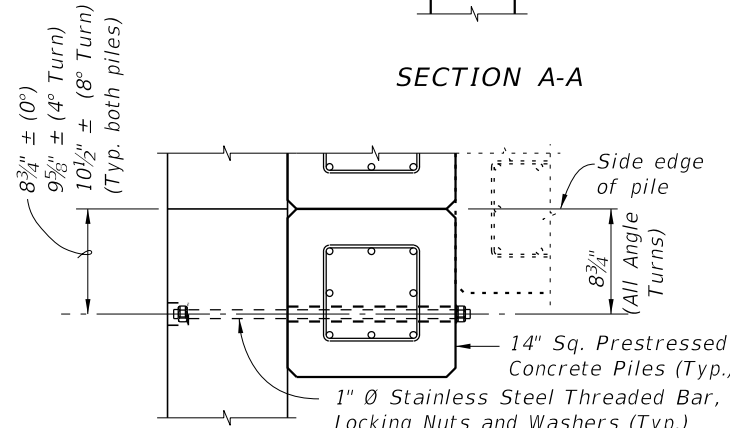

SECTION B-B

SECTION D-D TYPICAL AT INTERMEDIATE PILES

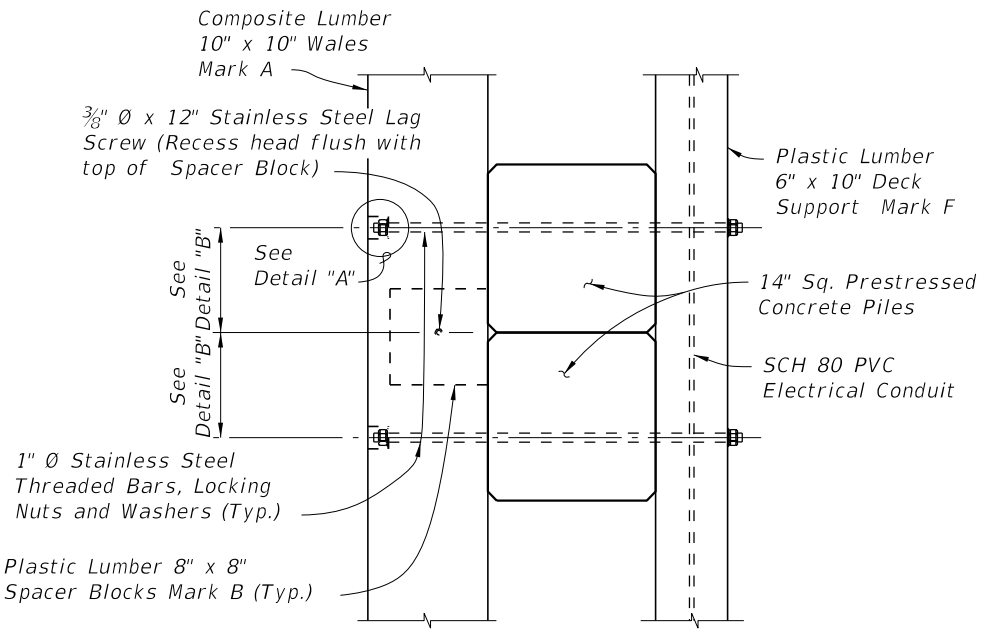

HANDRAIL DETAIL

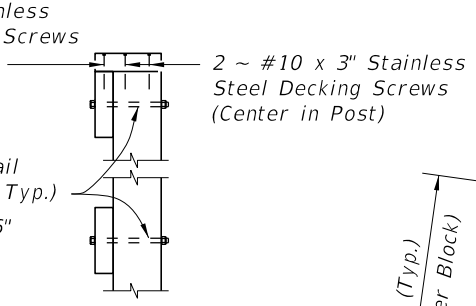

CROSS REFERENCES:  
For location of Sections A-A and B-B see Sheet 3.  
For Section E-E and Detail "A" see Sheet 5.

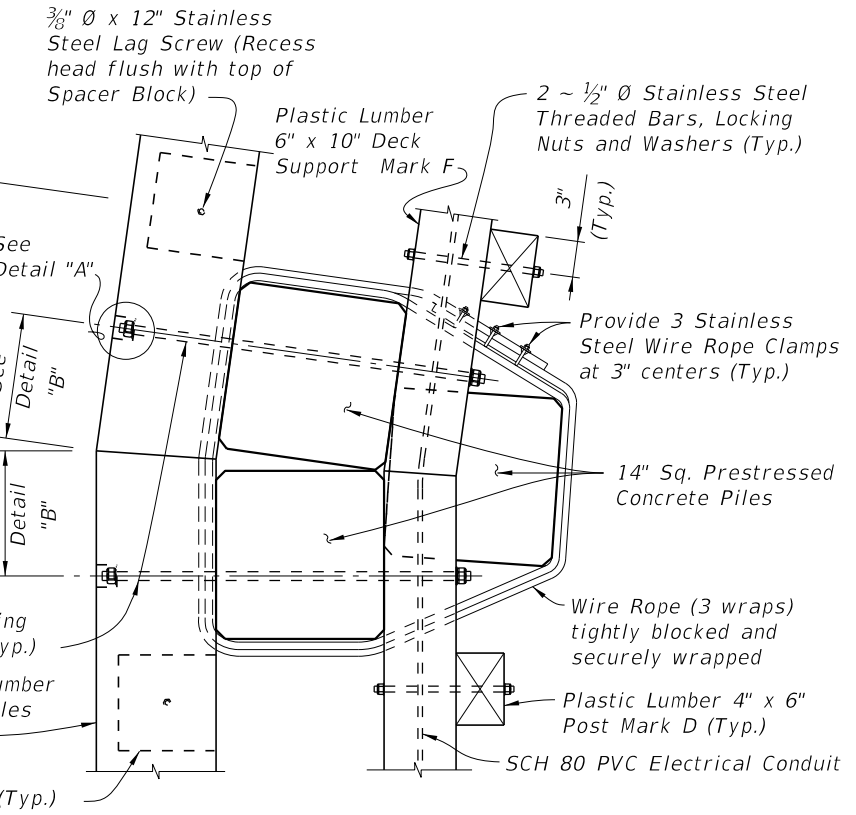

SECTION C-C TYPICAL FLARED SECTION (8° TURN SHOWN, 4° TURN SIMILAR)

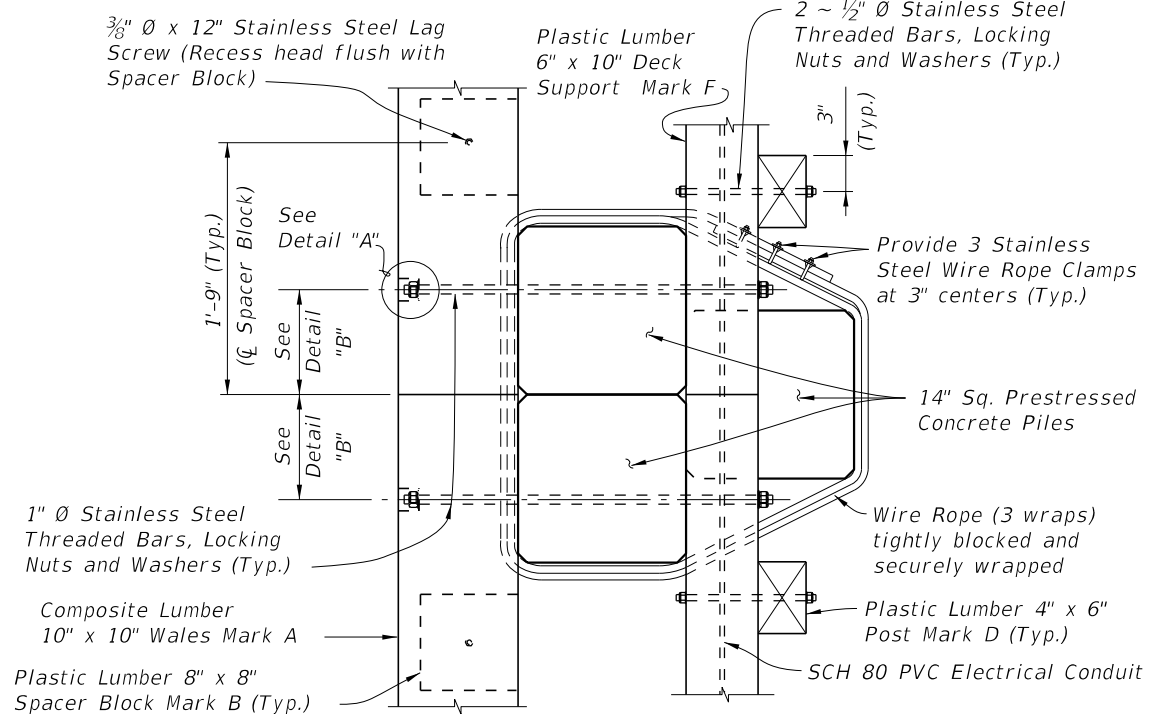

SECTION C-C TYPICAL STRAIGHT SECTION

10/26/2016 9:19:22 AM

LAST REVISION 01/01/12	DESCRIPTION:	FY 2017-18 DESIGN STANDARDS	FENDER SYSTEM - PRESTRESSED CONCRETE PILES	INDEX NO. 21930	SHEET NO. 4 of 7
---------------------------	--------------	--------------------------------	---	--------------------	---------------------

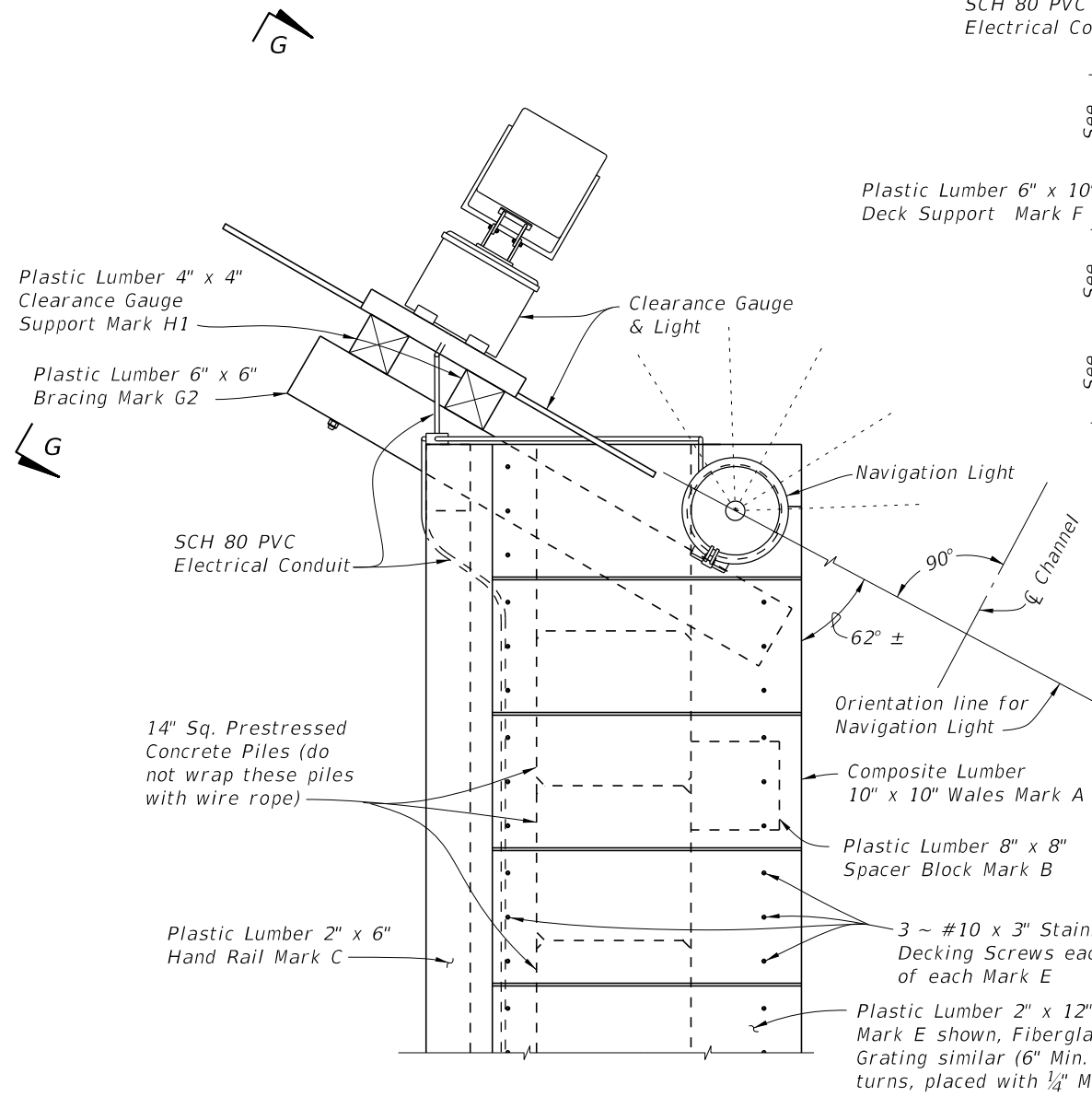

**VIEW F-F  
(SHOWING FENDER END WITH CLEARANCE GAUGE)**

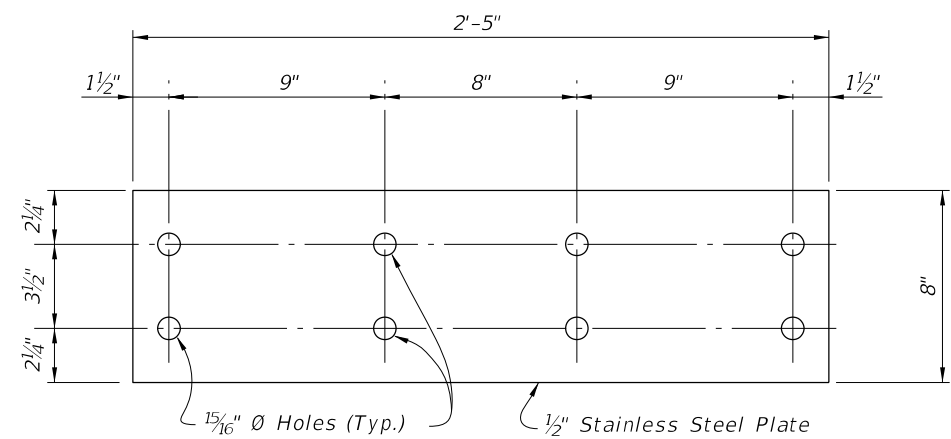

**SPLICE PLATE DETAIL**

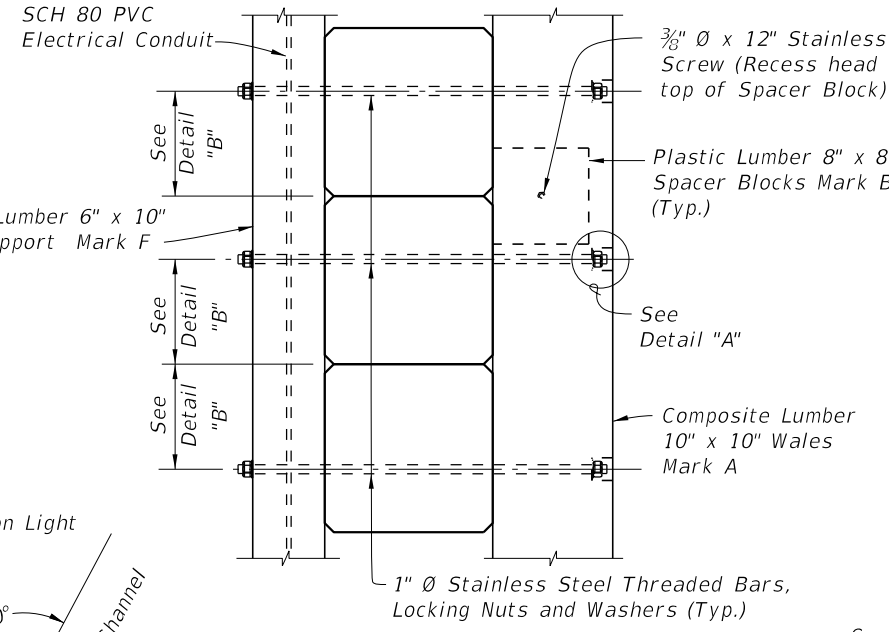

**PARTIAL VIEW F-F  
(SHOWING FENDER END; DECKING  
AND HANDRAIL NOT SHOWN  
FOR CLARITY)**

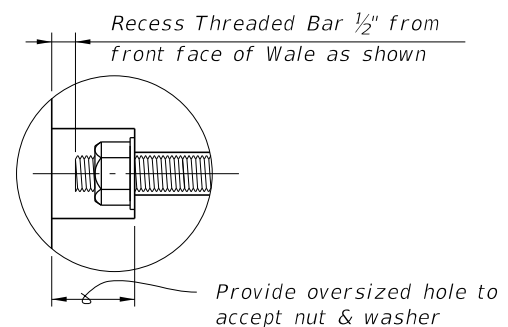

**DETAIL "A"**

**CROSS REFERENCES:**  
 For Navigation Lights and SCH 80 PVC Electrical Conduit Details see Design Standard Index 21220.  
 For View G-G and Clearance Gauge Details see Sheet 4.  
 For Detail "B" and location of Section E-E see Sheet 2.  
 For location of View F-F see Sheet 1.

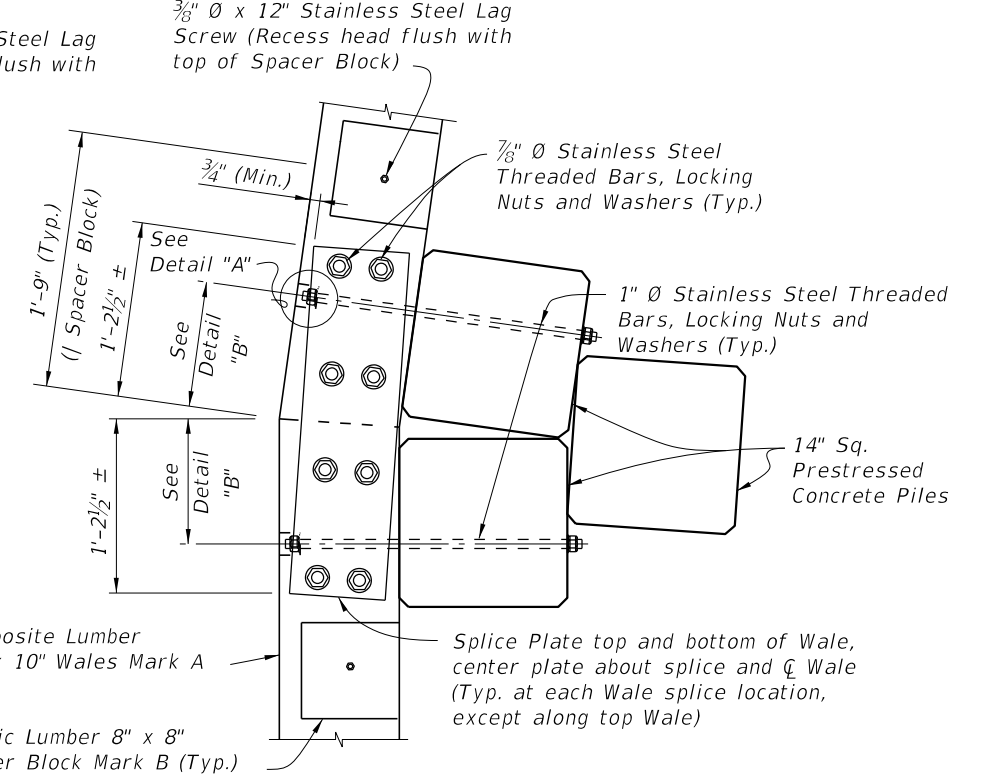

**SECTION E-E  
TYPICAL FLARED SECTION  
(8° TURN SHOWN, 4° TURN SIMILAR)**

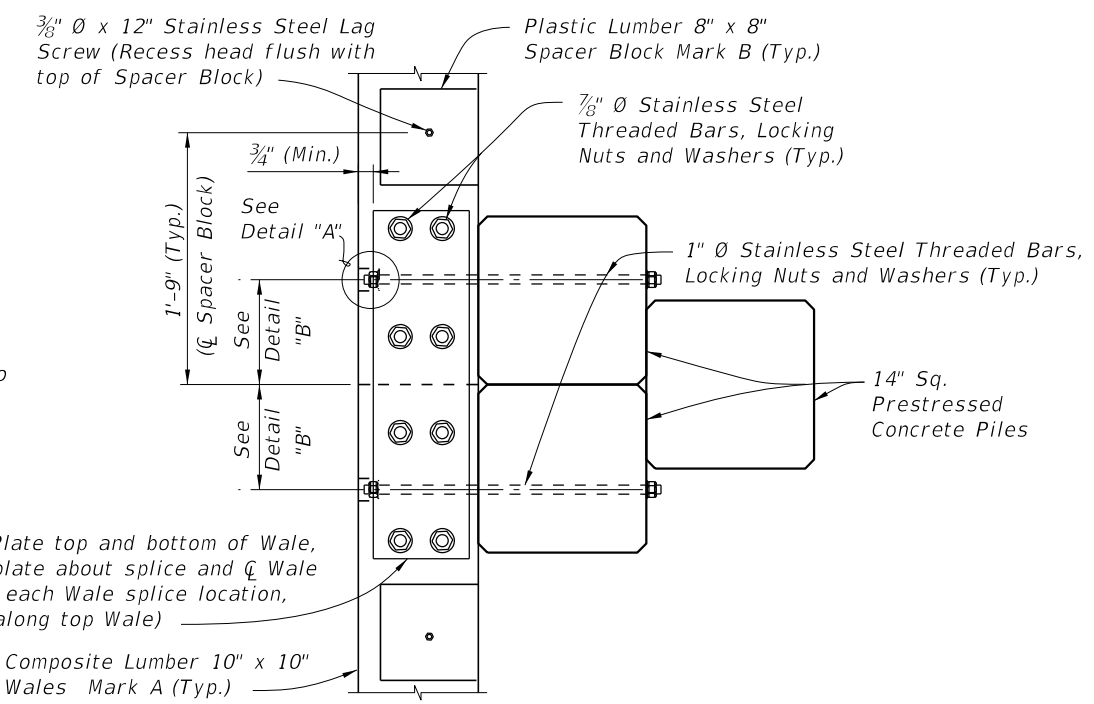

**SECTION E-E  
TYPICAL STRAIGHT SECTION**

10/26/2016 9:19:25 AM

LAST REVISION 07/01/11	DESCRIPTION:	<b>FY 2017-18 DESIGN STANDARDS</b>	<b>FENDER SYSTEM - PRESTRESSED CONCRETE PILES</b>	INDEX NO. <b>21930</b>	SHEET NO. <b>5 of 7</b>
---------------------------	--------------	--	---	---------------------------	----------------------------

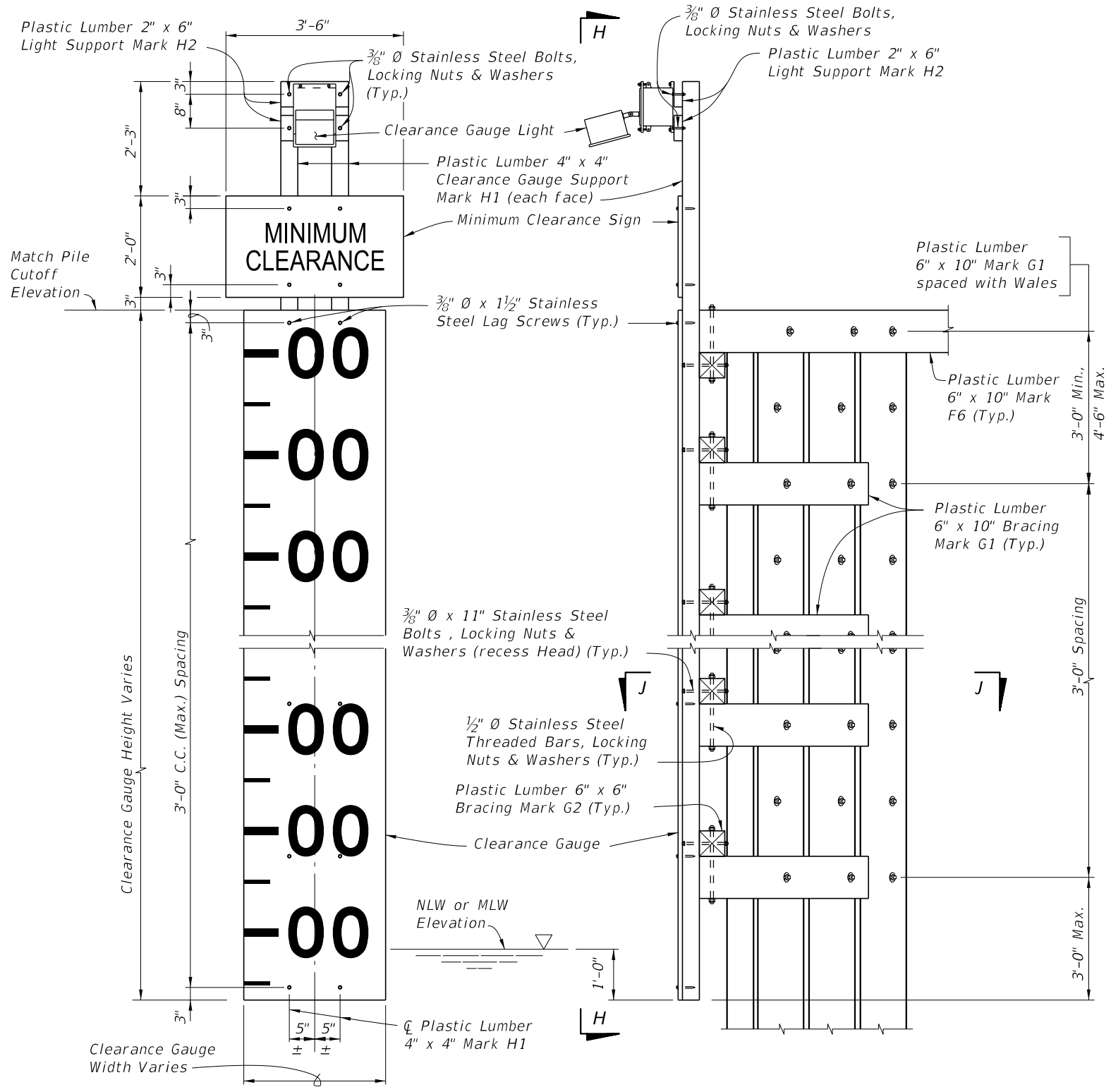

**VIEW H-H**  
(WALES, PILES AND BRACING  
NOT SHOWN FOR CLARITY)

**VIEW G-G**  
(WALES, DECKING AND HANDRAIL  
NOT SHOWN FOR CLARITY)

**CLEARANCE GAUGE DETAILS**

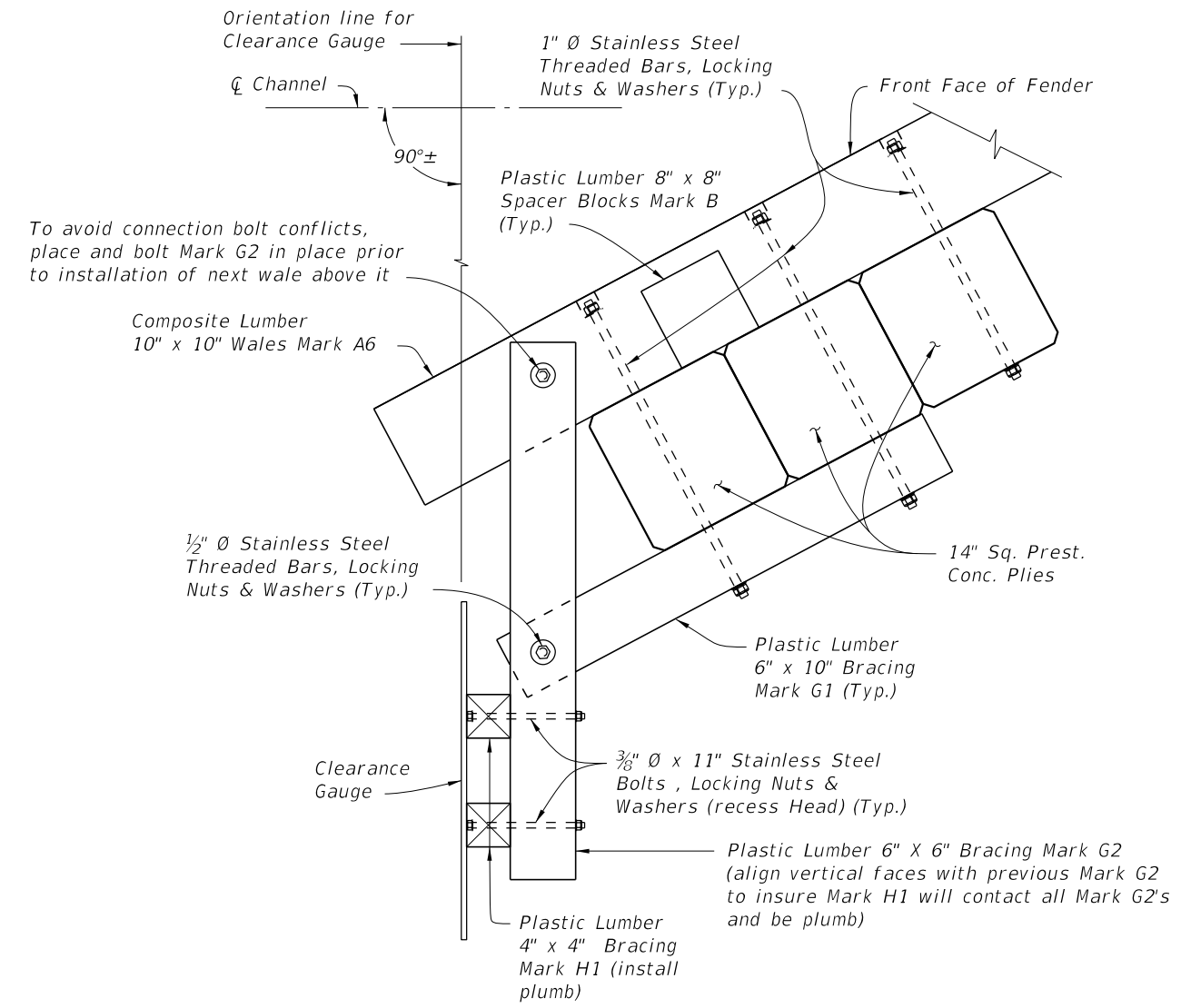

**SECTION J-J**

**CROSS REFERENCES:**

For Estimated Structural Composite and Plastic Lumber Bill of Materials Quantities and Fender System Table of Variables see Structures Plans.

For location of View G-G see Sheet 5.

10/26/2016 9:19:28 AM

LAST REVISION 01/01/12	REVISION	DESCRIPTION:	<b>FY 2017-18 DESIGN STANDARDS</b>	<b>FENDER SYSTEM - PRESTRESSED CONCRETE PILES</b>	INDEX NO. <b>21930</b>	SHEET NO. <b>6 of 7</b>
---------------------------	----------	--------------	--	---	---------------------------	----------------------------

**\* STRUCTURAL COMPOSITE LUMBER BILL OF MATERIALS**

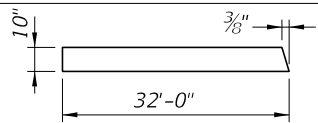
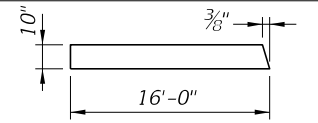
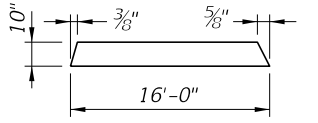
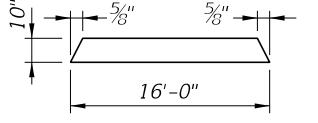
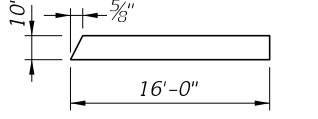
MARK	SIZE (NOMINAL)	DIMENSIONS	BOARD FT. PER EACH	NO. REQD.	QUANTITY
A1	10" X 10" COMPOSITE LUMBER	32'-0" (STRAIGHT)	266.6	See Estimated Structural Composite and Plastic Lumber Bill of Materials Table in Structures Plans	
A2	10" X 10" COMPOSITE LUMBER		266.6		
A3	10" X 10" COMPOSITE LUMBER		133.3		
A4	10" X 10" COMPOSITE LUMBER		133.3		
A5	10" X 10" COMPOSITE LUMBER		133.3		
A6	10" X 10" COMPOSITE LUMBER		133.3		

\* All Plastic Lumber and Composite Lumber Dimensions and Quantities shown are based on Nominal Lumber Dimensions and may vary depending on Actual Lumber Dimension.

\*\* Provide Fiberglass Open Grating in lieu of 2" X 12" Plastic Lumber when called for in the Plans. Mounting hardware shall be Stainless Steel, install per Manufacturer's recommendations. See Structures Plans for Notes and Details.

**\* PLASTIC LUMBER BILL OF MATERIALS**

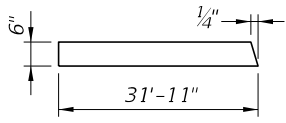
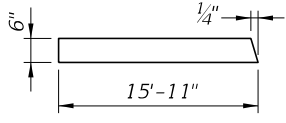
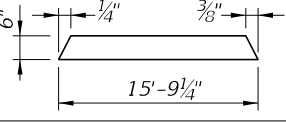
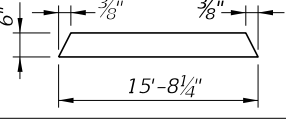
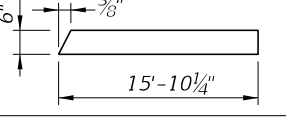
MARK	SIZE (NOMINAL)	DIMENSIONS	BOARD FT. PER EACH	NO. REQD.	QUANTITY
B	8" X 8" PLASTIC LUMBER	8" (STRAIGHT)	3.6	See Estimated Structural Composite and Plastic Lumber Bill of Materials Table in Structures Plans	
C	2" X 6" PLASTIC LUMBER	16'-0" (STRAIGHT) (Trim & Miter Ends as required)	16.0		
D	4" X 6" PLASTIC LUMBER	4'-4" (STRAIGHT)	8.7		
** E	2" X 12" PLASTIC LUMBER	2'-6" (STRAIGHT) (Miter as required, 6" Min. width)	5.0		
F1	6" X 10" PLASTIC LUMBER	32'-0" (STRAIGHT)	160.0		
F2	6" X 10" PLASTIC LUMBER		159.6		
F3	6" X 10" PLASTIC LUMBER		79.6		
F4	6" X 10" PLASTIC LUMBER		78.8		
F5	6" X 10" PLASTIC LUMBER		78.4		
F6	6" X 10" PLASTIC LUMBER		79.3		
G1	6" X 10" PLASTIC LUMBER	3'-8" (STRAIGHT)	18.3		
G2	6" X 6" PLASTIC LUMBER	4'-1" (STRAIGHT)	12.3		
H1	4" X 4" PLASTIC LUMBER	PILE CUTOFF ELEV. MINUS NLW OR MLW ELEV. PLUS 5'-6" (STRAIGHT)	1.3 PER LF EACH		
H2	2" X 6" PLASTIC LUMBER	1'-2" (STRAIGHT)	1.2		

10/26/2016 9:19:30 AM