

TYPICAL SECTION THRU STRIP SEAL EXPANSION JOINT
 (Begin or End Concrete Girder Bridge shown,
 Intermediate Supports and Steel Girder Bridge similar.)
 Reinforcing Steel and Girder details not shown for clarity.)

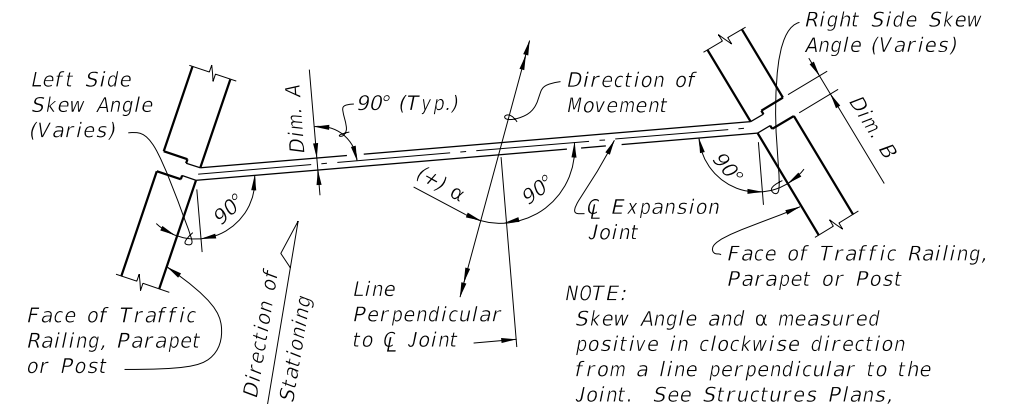

MOVEMENT SCHEMATIC

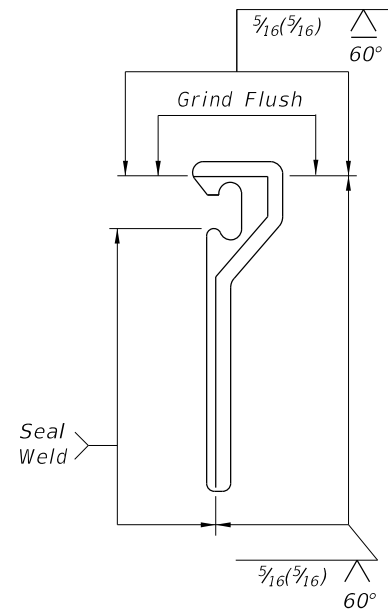

SHOP SPLICE DETAIL

GENERAL NOTES:

1. Furnish Strip Seal Expansion Joint Systems in accordance with Specification Section 458.
2. Shape of Edge Rail shown is representative, minor variations depending on manufacturer are permitted.
3. Recess the Edge Rail below the concrete surface in accordance with Specification Section 458.
4. Refer to the Expansion Joint Data Table in the Structures Plans for joint movement and Dimension A.
5. Refer to Specification Section 458 for installation and fabrication requirements.

10/26/2016 9:05:05 AM

LAST REVISION 07/01/13	REVISION	DESCRIPTION:	 FY 2017-18 DESIGN STANDARDS	STRIP SEAL EXPANSION JOINT	INDEX NO. 21100	SHEET NO. 1 of 3
---------------------------	----------	--------------	--	-----------------------------------	---------------------------	----------------------------

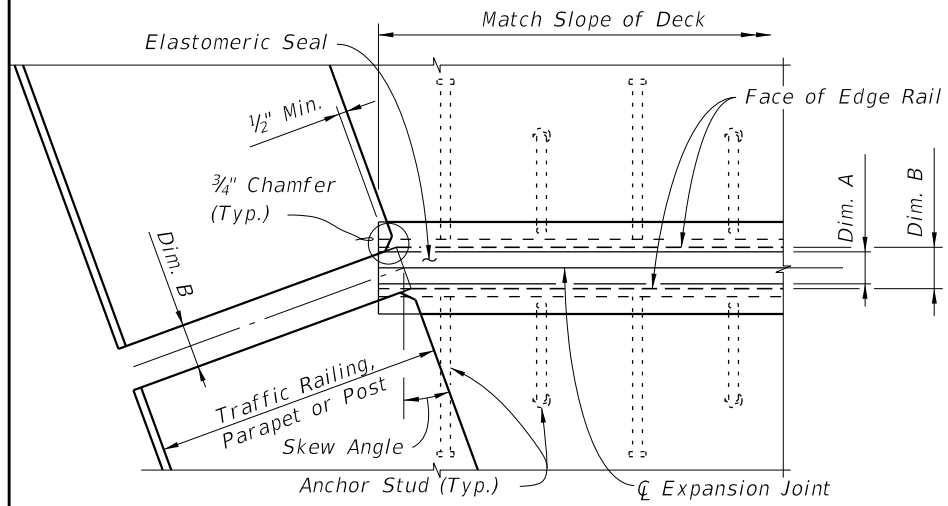

PARTIAL PLAN VIEW OF SKEWED JOINTS

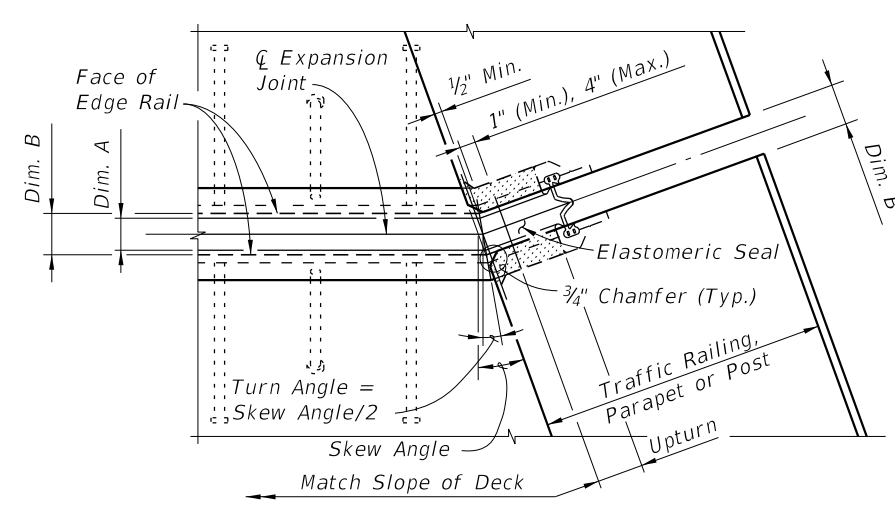

PARTIAL PLAN VIEW OF JOINTS SKEWED GREATER THAN 6°

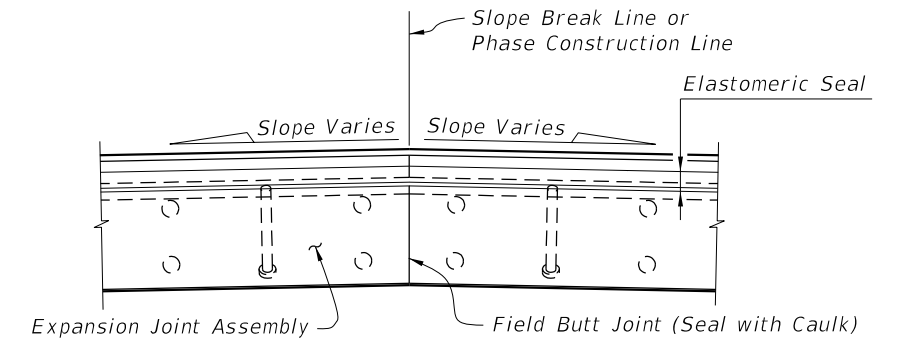

PARTIAL SECTION ALONG Q JOINT AT FIELD BUTT JOINT LOCATION (CROWNED DECK OR SLAB SHOWN)

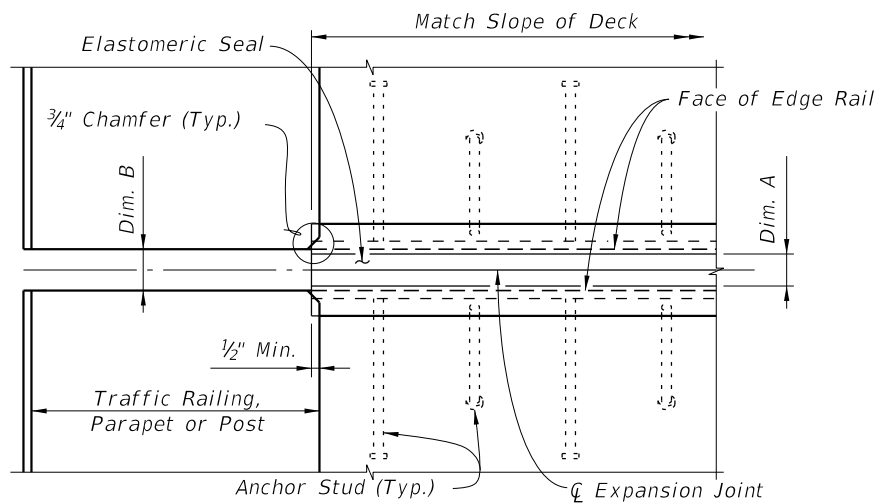

PARTIAL PLAN VIEW OF NONSKEWED JOINTS

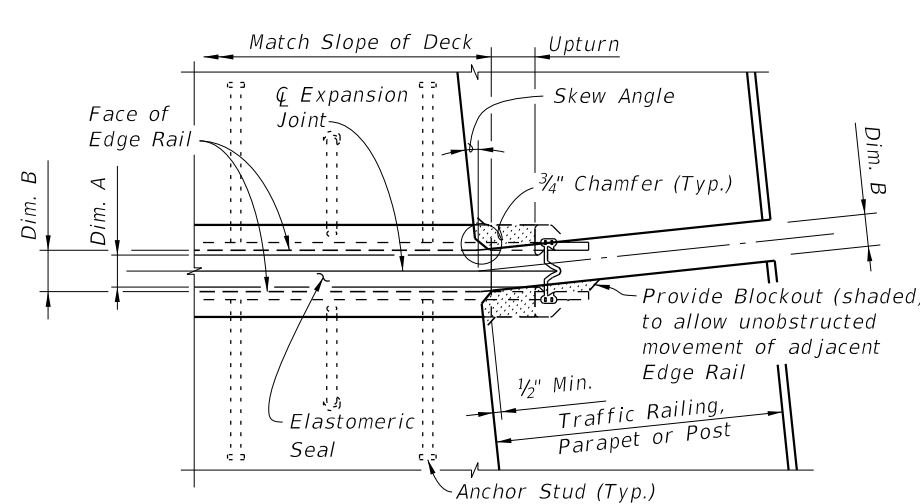

PARTIAL PLAN VIEW OF NONSKEWED JOINTS & JOINTS SKEWED 6° OR LESS

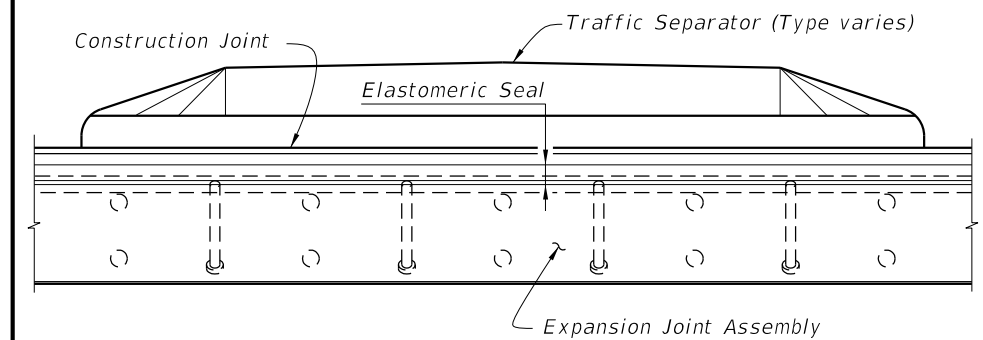

PARTIAL SECTION ALONG Q JOINT THRU TRAFFIC SEPARATOR

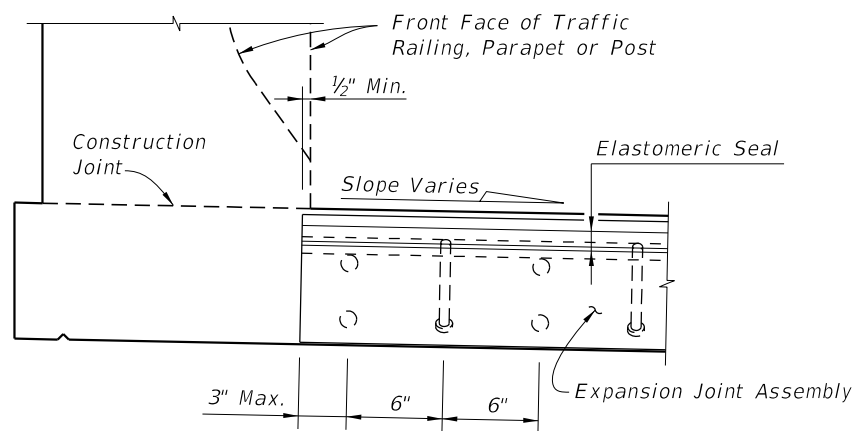

PARTIAL SECTION ALONG Q JOINT

JOINT TREATMENT AT HIGH SIDE OF DECK WITH SLOPE $\geq 1\%$
(Sidewalk Cover Plate where applicable not shown for clarity)

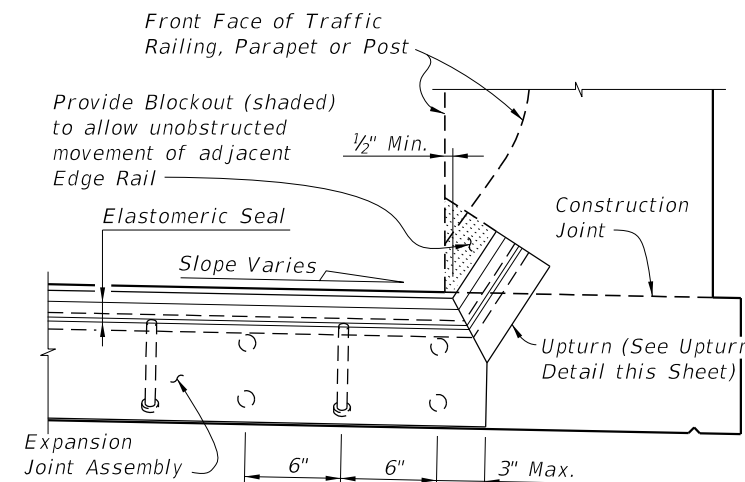

PARTIAL SECTION ALONG Q JOINT

JOINT TREATMENT AT LOW SIDE OF DECK & HIGH SIDE OF DECK WITH SLOPE $< 1\%$
(Sidewalk Cover Plate where applicable not shown for clarity)

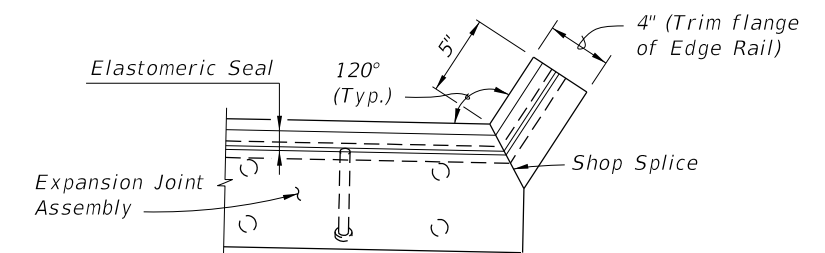

UPTURN DETAIL (TYPICAL AT TRAFFIC BARRIERS AND PARAPETS)

10/26/2016 9:05:07 AM

LAST REVISION 07/01/14	REVISION	DESCRIPTION:
---------------------------	----------	--------------

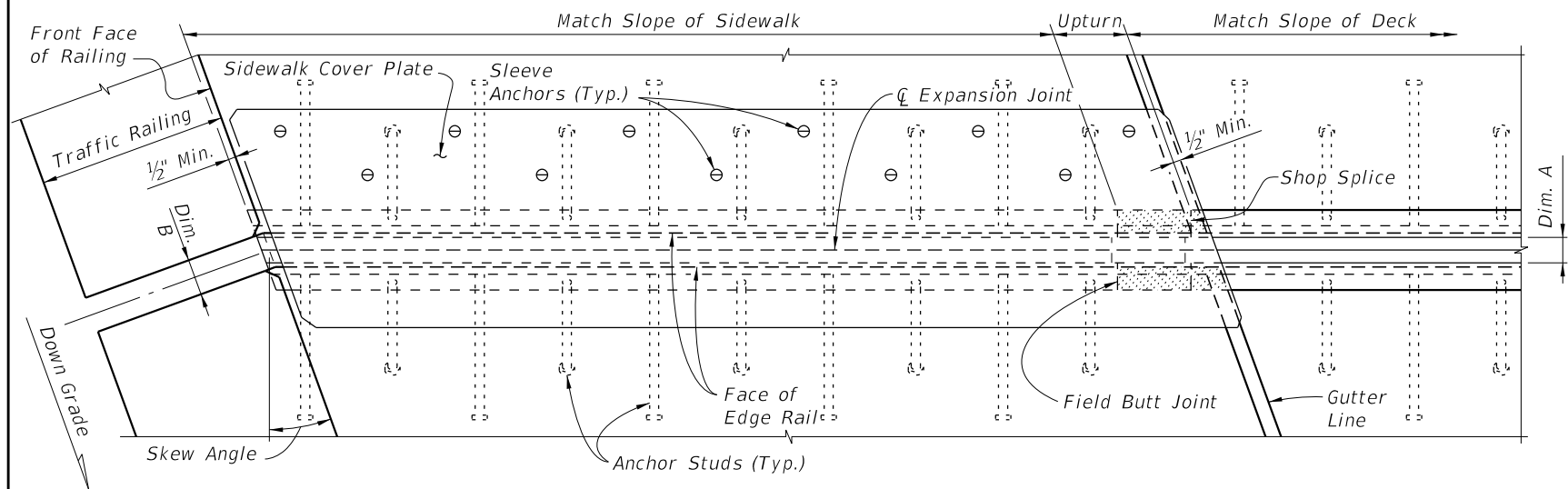

PARTIAL PLAN VIEW OF SKEWED JOINTS

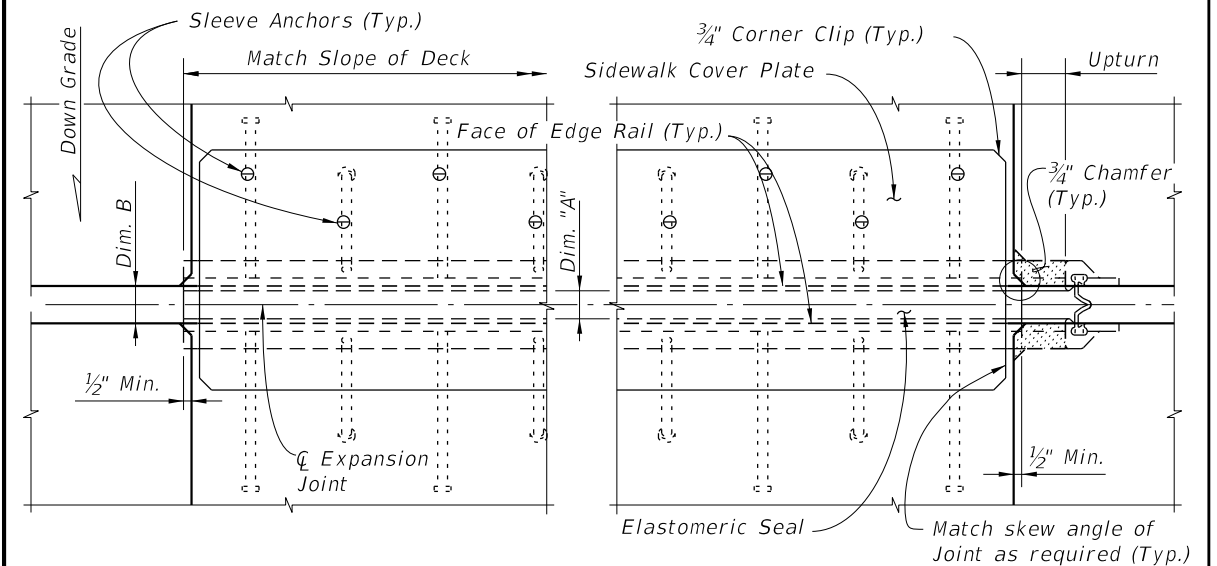

PARTIAL PLAN VIEW

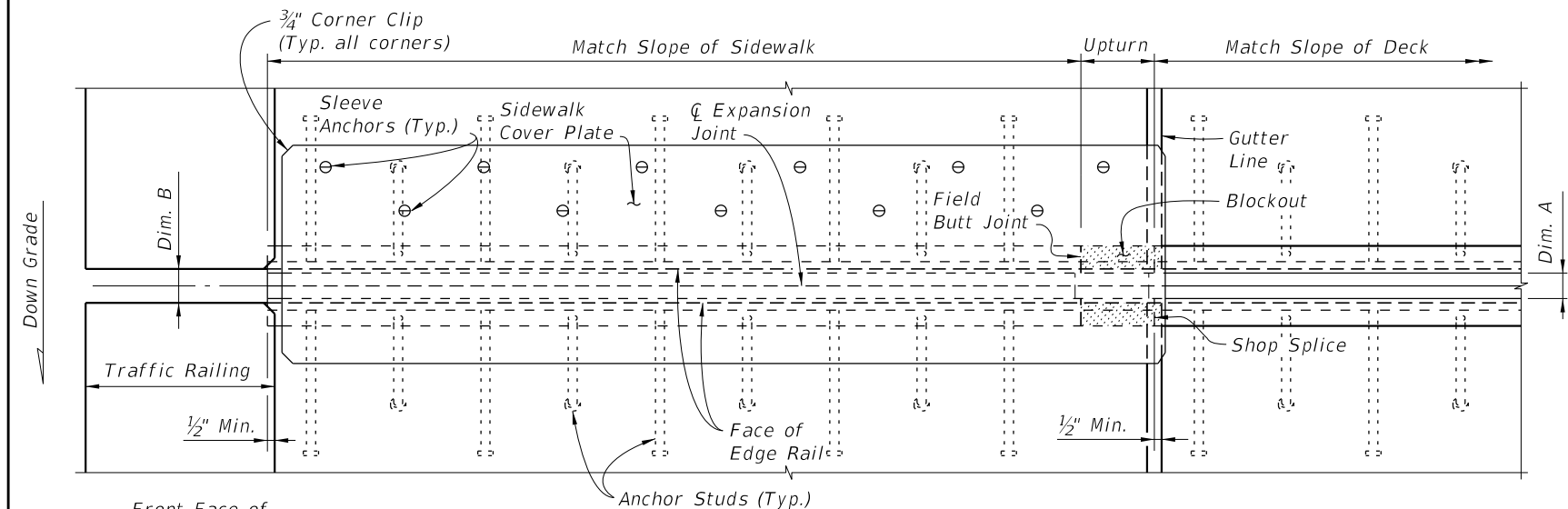

PARTIAL PLAN VIEW OF NONSKEWED JOINTS

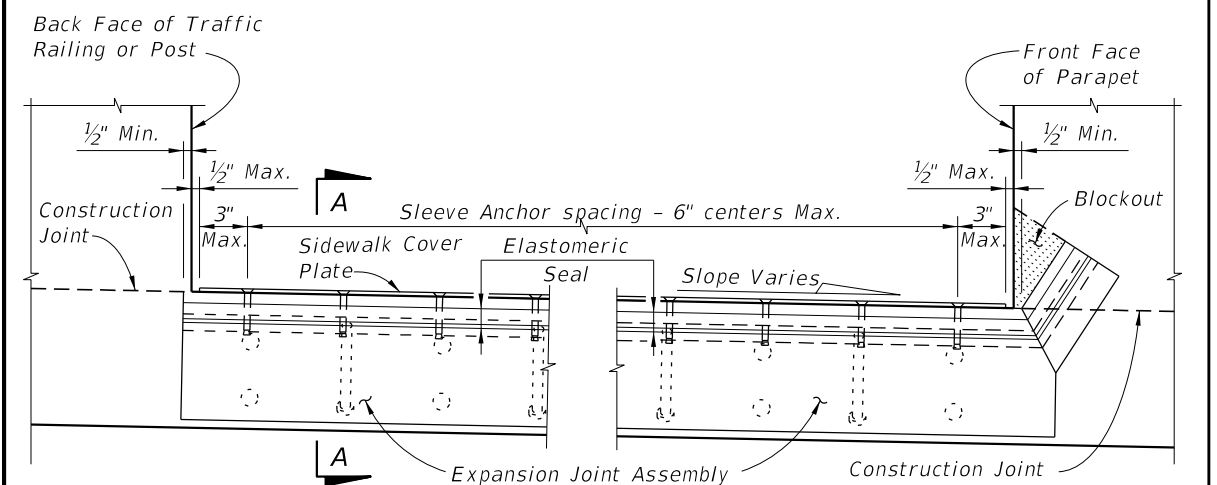

PARTIAL SECTION ALONG Q JOINT

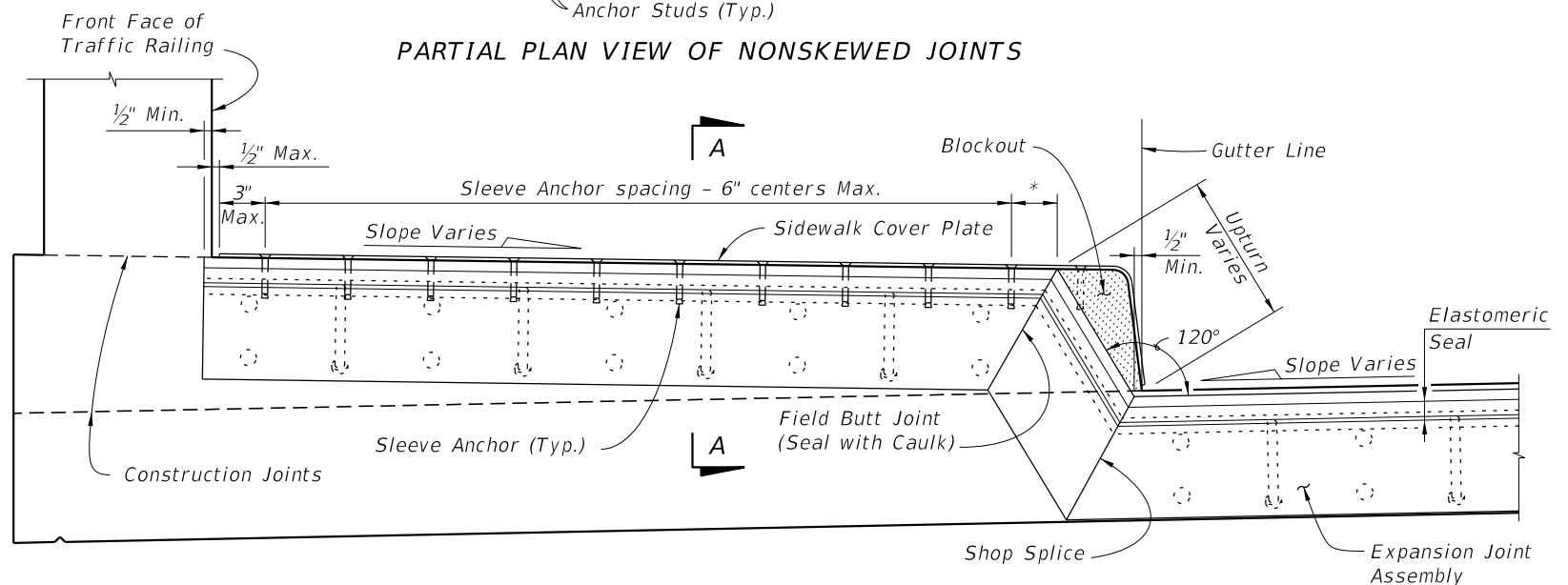

PARTIAL SECTION ALONG Q JOINT

RAISED SIDEWALK DETAIL

FLUSH SIDEWALK DETAIL

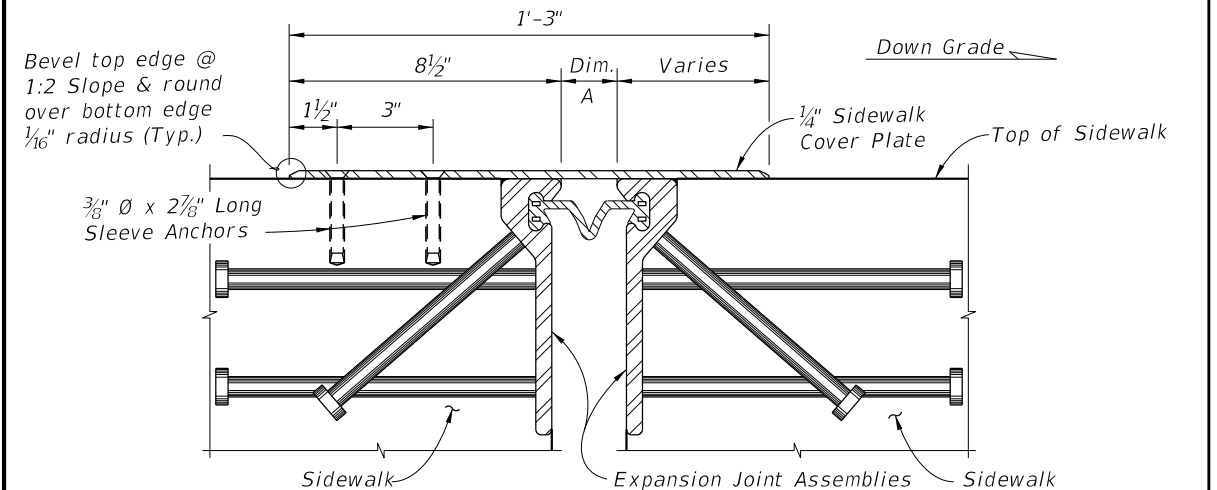

SECTION A-A

* Distance from Q Sleeve Anchor to edge of concrete is 2 inches minimum, 3 inches maximum.

10/26/2016 9:05:10 AM

LAST REVISION 07/01/13	REVISION	DESCRIPTION:	 FY 2017-18 DESIGN STANDARDS	STRIP SEAL EXPANSION JOINT	INDEX NO. 21100	SHEET NO. 3 of 3
---------------------------	----------	--------------	---	----------------------------	--------------------	---------------------

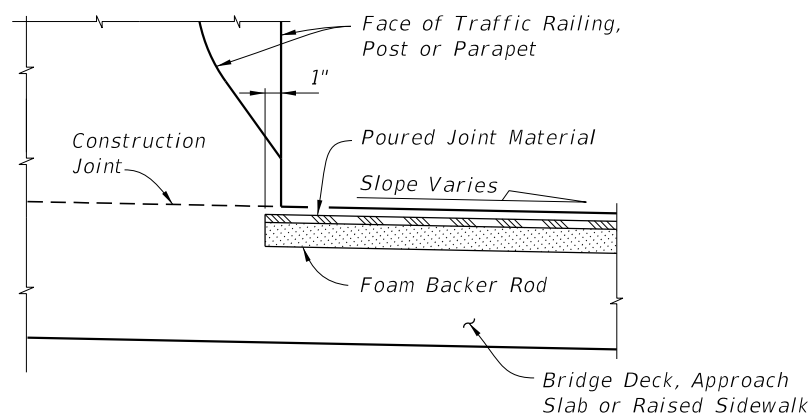

PARTIAL SECTION ALONG Q̄ JOINT
JOINT TREATMENT AT HIGH SIDE OF
DECK WITH SLOPES 1% OR GREATER

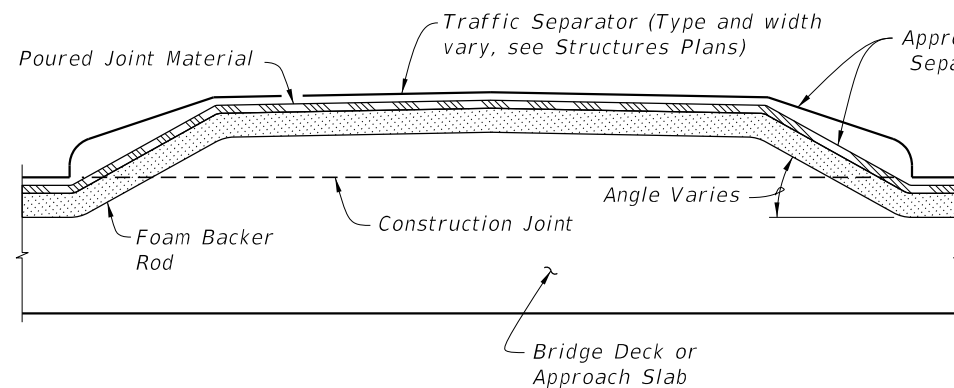

PARTIAL SECTION ALONG Q̄ JOINT,
JOINT TREATMENT AT TRAFFIC SEPARATOR

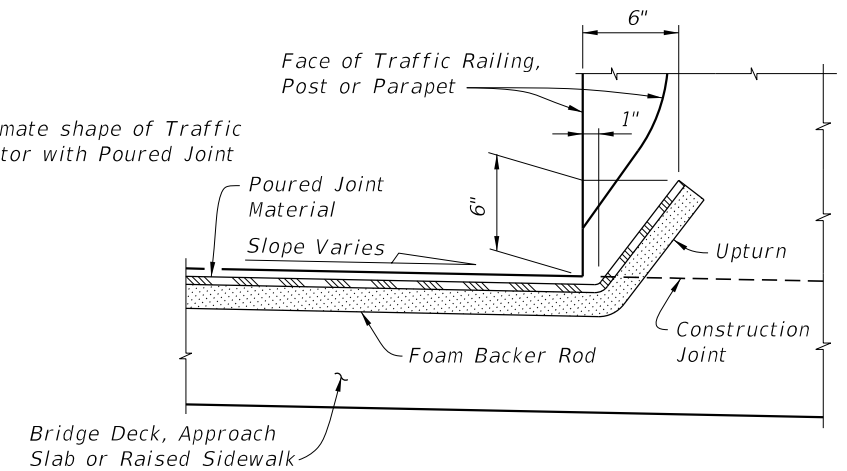

PARTIAL SECTION ALONG Q̄ JOINT
JOINT TREATMENT AT LOW SIDE OF DECK OR
HIGH SIDE OF DECK WITH SLOPES < 1%

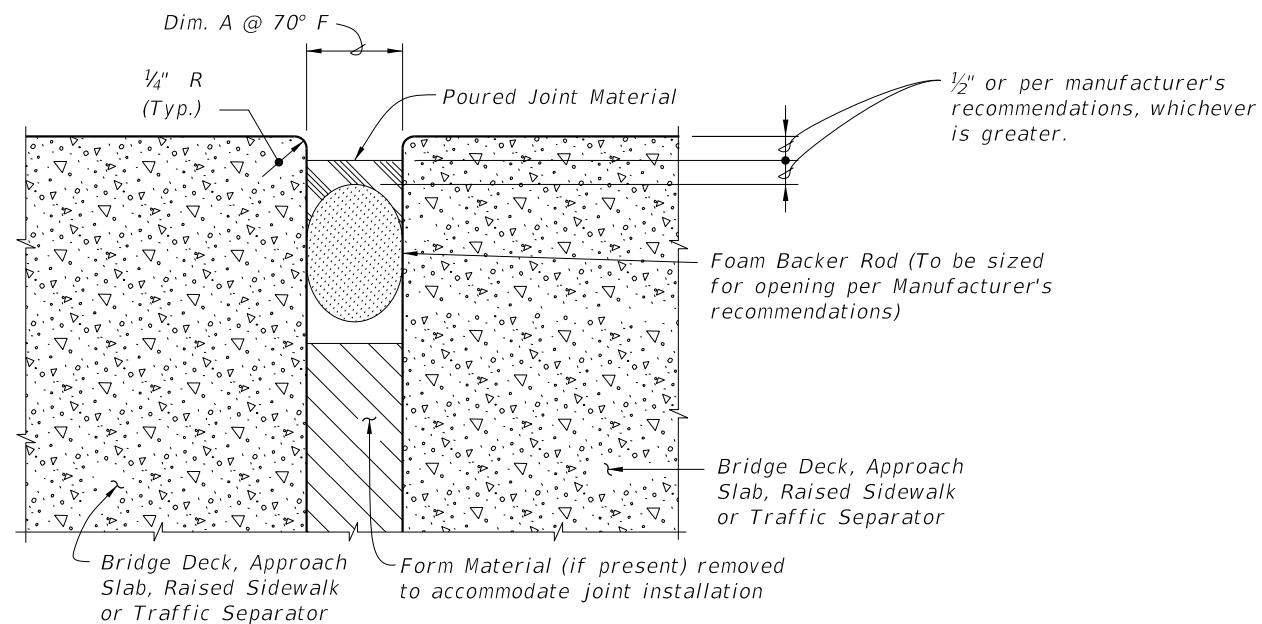

TYPICAL SECTION THRU JOINT

GENERAL NOTES:

1. Furnish and install Poured Joint With Backer Rod Expansion Joint Systems in accordance with Specification Sections 458 and 932 using Type D silicone sealant material.
2. Refer to the Structures Plans, Poured Expansion Joint Data Table for Dim. A @ 70° F.

10/26/2016 9:05:31 AM

LAST REVISION 07/01/14	REVISION	DESCRIPTION:
---------------------------	----------	--------------

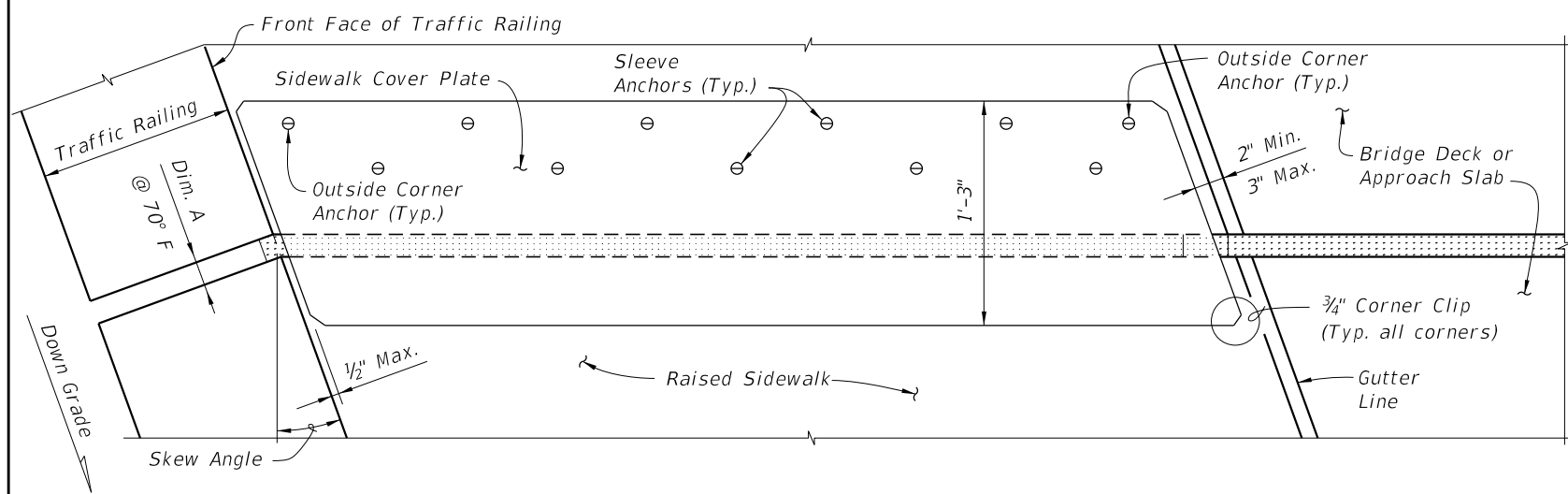

PARTIAL PLAN VIEW OF SKEWED JOINTS

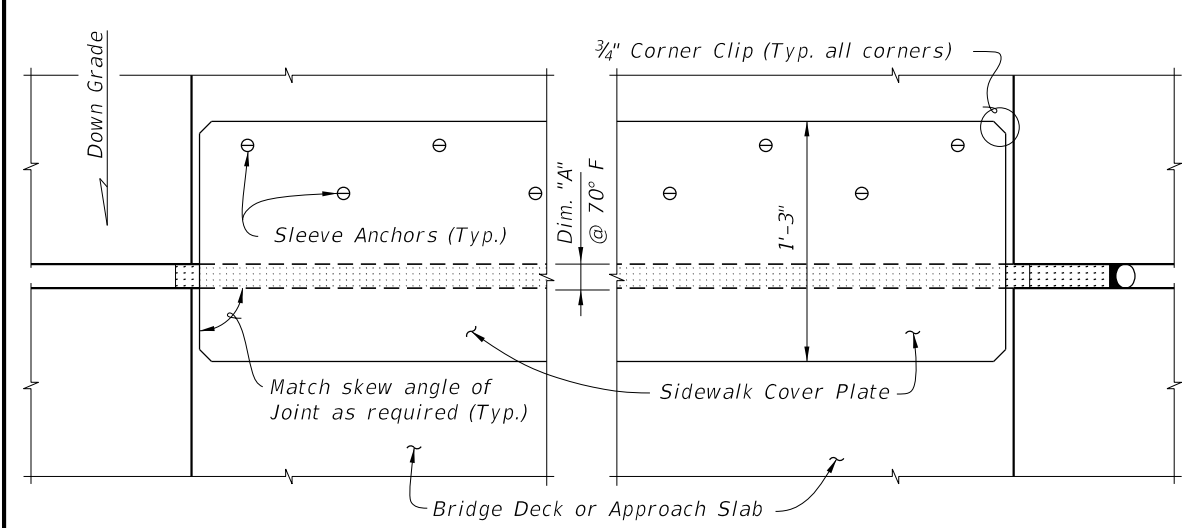

PARTIAL PLAN VIEW

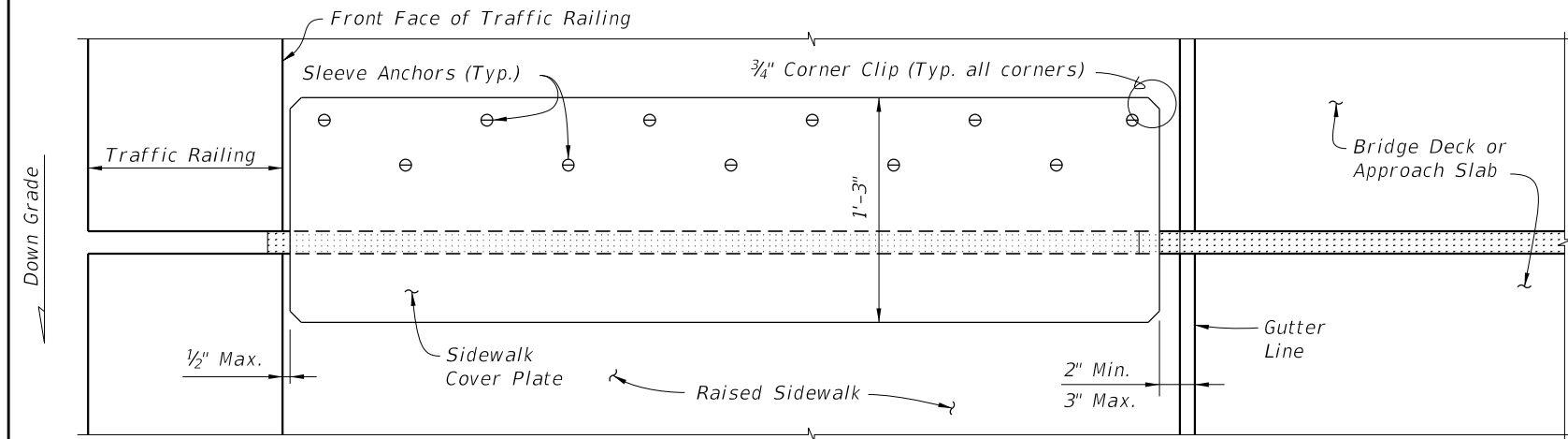

PARTIAL PLAN VIEW OF NON-SKEWED JOINTS

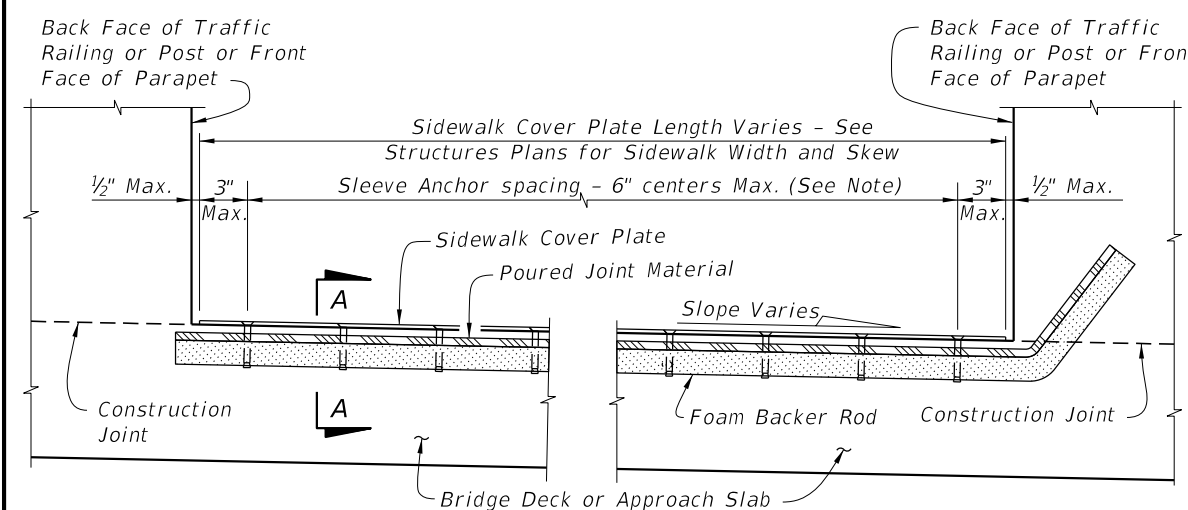

PARTIAL SECTION ALONG Q-JOINT

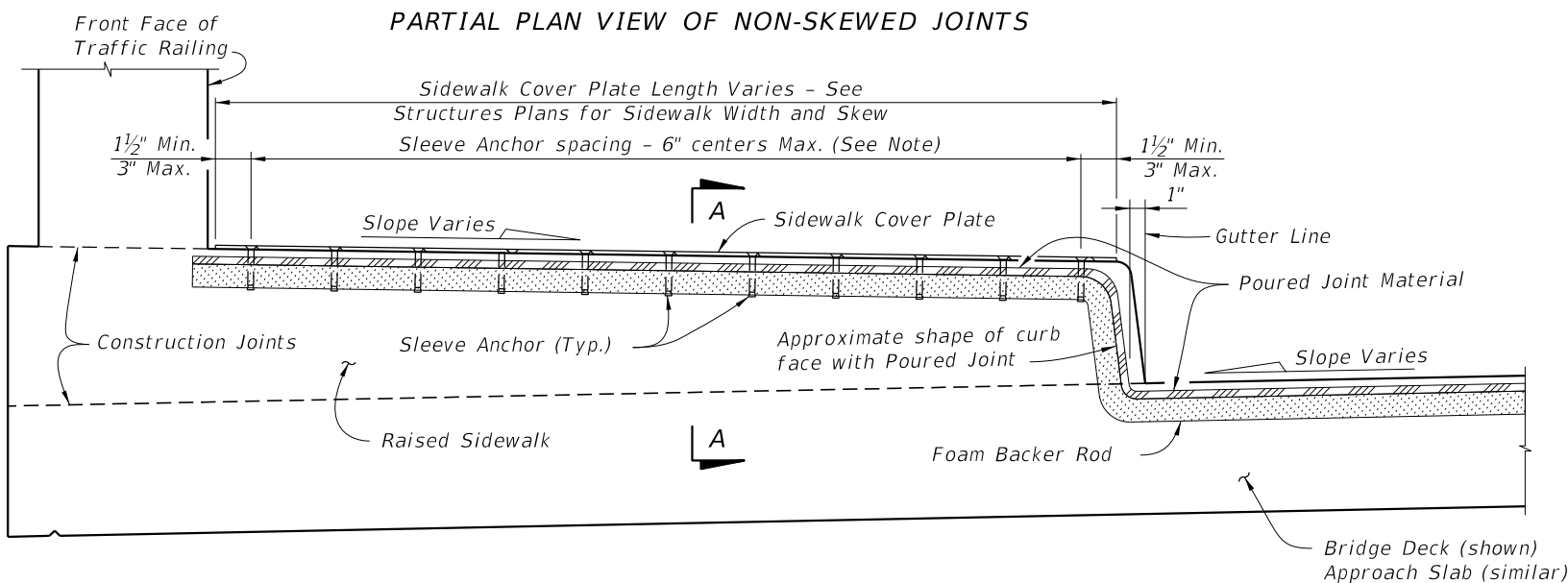

PARTIAL SECTION ALONG Q-JOINT

RAISED SIDEWALK DETAIL

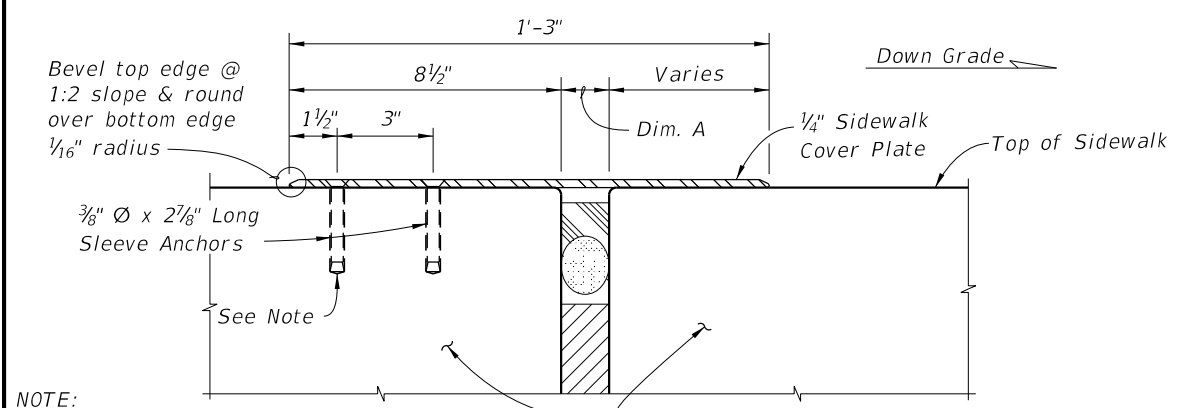

NOTE: Sleeve Anchors are required at the two outside corners of the Sidewalk Cover Plate. Space Sleeve Anchors uniformly between the corner anchors.

SECTION A-A

10/26/2016 9:05:33 AM

LAST REVISION	DESCRIPTION:
07/01/13	