

CONVENTIONAL REINFORCING BAR BENDING DETAILS

BILL OF REINFORCING STEEL				
MARK	NOTE NUMBERS	SIZE	NUMBER REQUIRED	LENGTH (NOTE 2)
A	—	6	8	28'-0"
C1	7, 8 & 9	3	20 (End 1)	Varies
C2	7, 8 & 9	3	20 (End 2)	Varies
D1	7, 8, 9 & 10	3	40 (End 1)	Varies
D2	7, 8, 9 & 10	3	40 (End 2)	Varies
D3	9 & 10	3	See Table	4'-3"
K	5, 6, 8, 9 & 10	5	See Table	7'-8"
M1	7 & 9	4	18 (End 1)	Varies
M2	7 & 9	4	18 (End 2)	Varies
M3	9	4	See Table	3'-8"
N	4 & 12	3/8" Ø Strand	4	Dim. L
Y	8 & 9	5	16	6'-0"
Z	5, 6, 8, 9 & 10	5	12	7'-2"

BENDING DIAGRAMS (See Note 2)

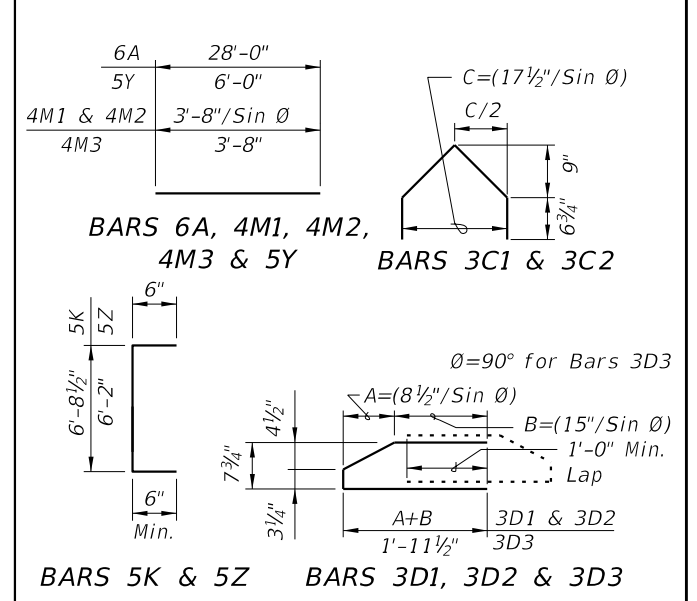

NOTES:
 A. Work this Index with Index 20010 - Typical Florida-I Beam Details and Notes and the Florida-I Beam - Table of Beam Variables in Structures Plans.
 B. For referenced notes, see Index 20010.
 C. For Dimensions A, B, C, D, L, R & V1 and number of spaces S1 thru S4, see Florida-I Beam - Table of Beam Variables in Structures Plans.

SDATES

LAST REVISION 11/01/16	DESCRIPTION:
---------------------------	--------------

ALTERNATE REINFORCING STEEL (WWR) DETAILS

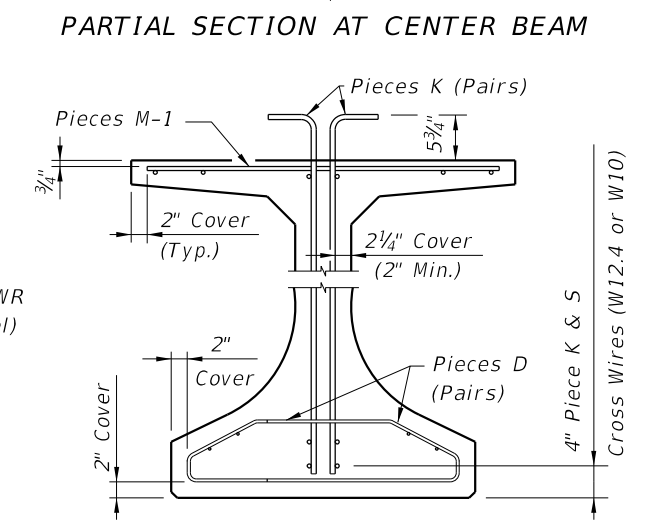
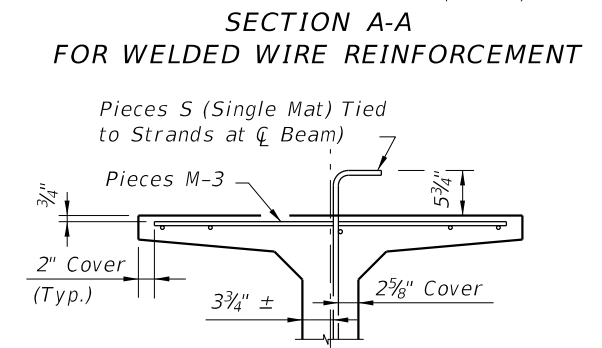
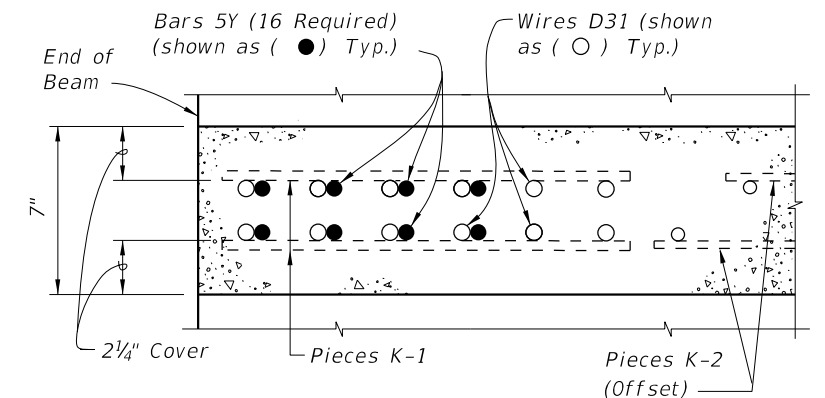
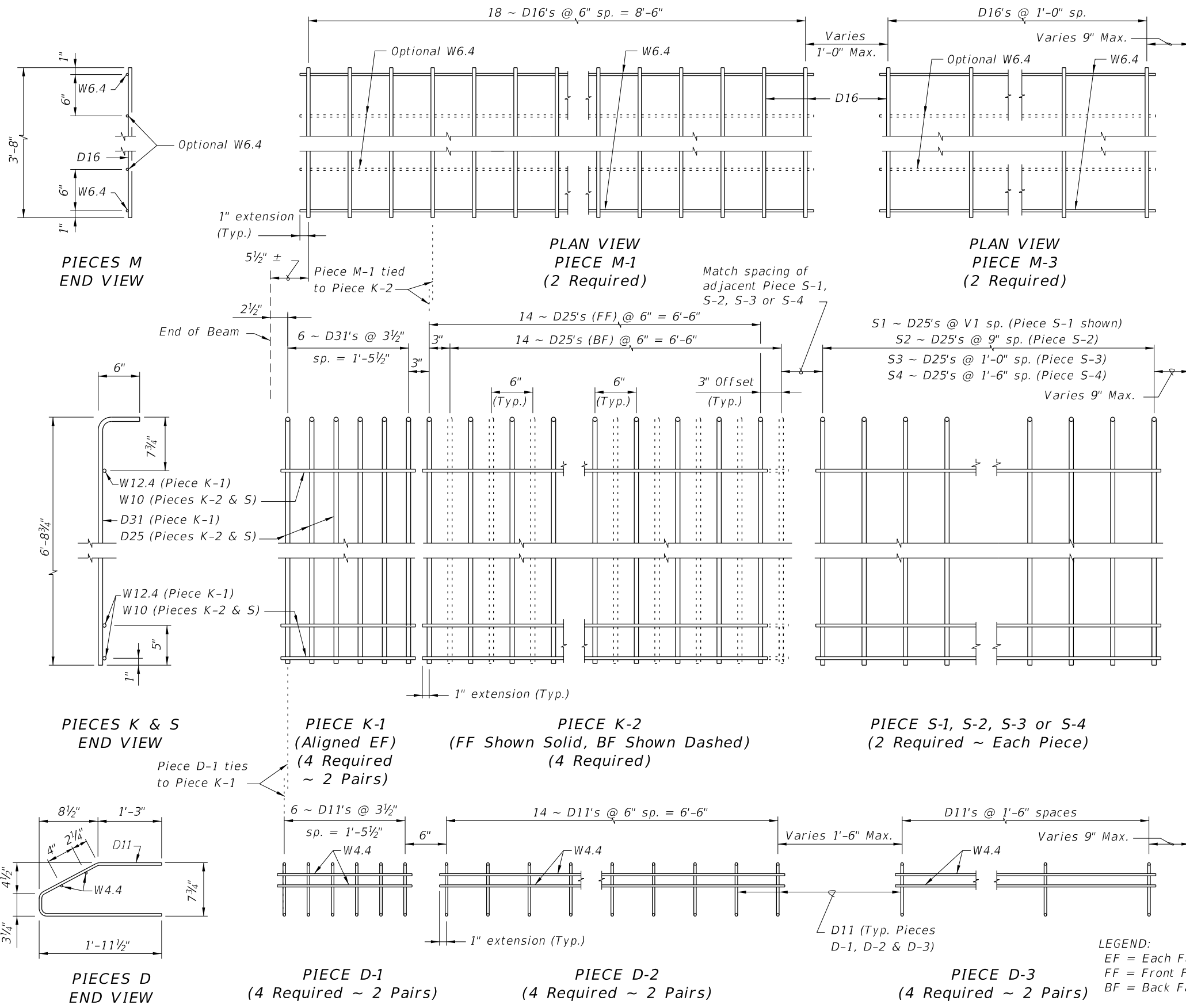

NOTES:

- See Sheet 1 for placement details & Table of Beam Variables in Structures Plans for variables S1, S2, S3, S4 & V1.
- Place Conventional Reinforcing Bars 6A & 3C as shown on Sheet 1. Place additional Bars 5Y as shown in Section A-A for WWR. Bars 5Z will not be used with the WWR Option.
- Pieces may be fabricated in multiple length sections.
- For beams with skewed end conditions, Pieces D-1, D-2 & M-1 shall not be used; Conventional Reinforcing Bars D1, D2, C1, C2, M1 & M2 shall be used. See Index 20010 Skewed Beam End Details and Note 9 for placement details. Shift Pieces K & Bars 5Y to accommodate skewed end conditions and align with Bars C and D.

LEGEND:
 EF = Each Face
 FF = Front Face
 BF = Back Face

10/26/2016 8:47:31 AM

LAST REVISION 11/01/16	DESCRIPTION:	FY 2017-18 DESIGN STANDARDS	FLORIDA-I 78 BEAM - STANDARD DETAILS	INDEX NO. 20078	SHEET NO. 2 of 2
---------------------------	--------------	--------------------------------	--------------------------------------	--------------------	---------------------