

GENERAL NOTES:

1. It shall be the contractors responsibility to provide a complete service assembly as per the plans and service specifications.
2. The service installation shall meet the requirements of the national electric code and applicable local codes.
3. Shop drawings are not required for service equipment, unless noted in the plans.
4. A Pull Box is required at each service point, see Index 17700.

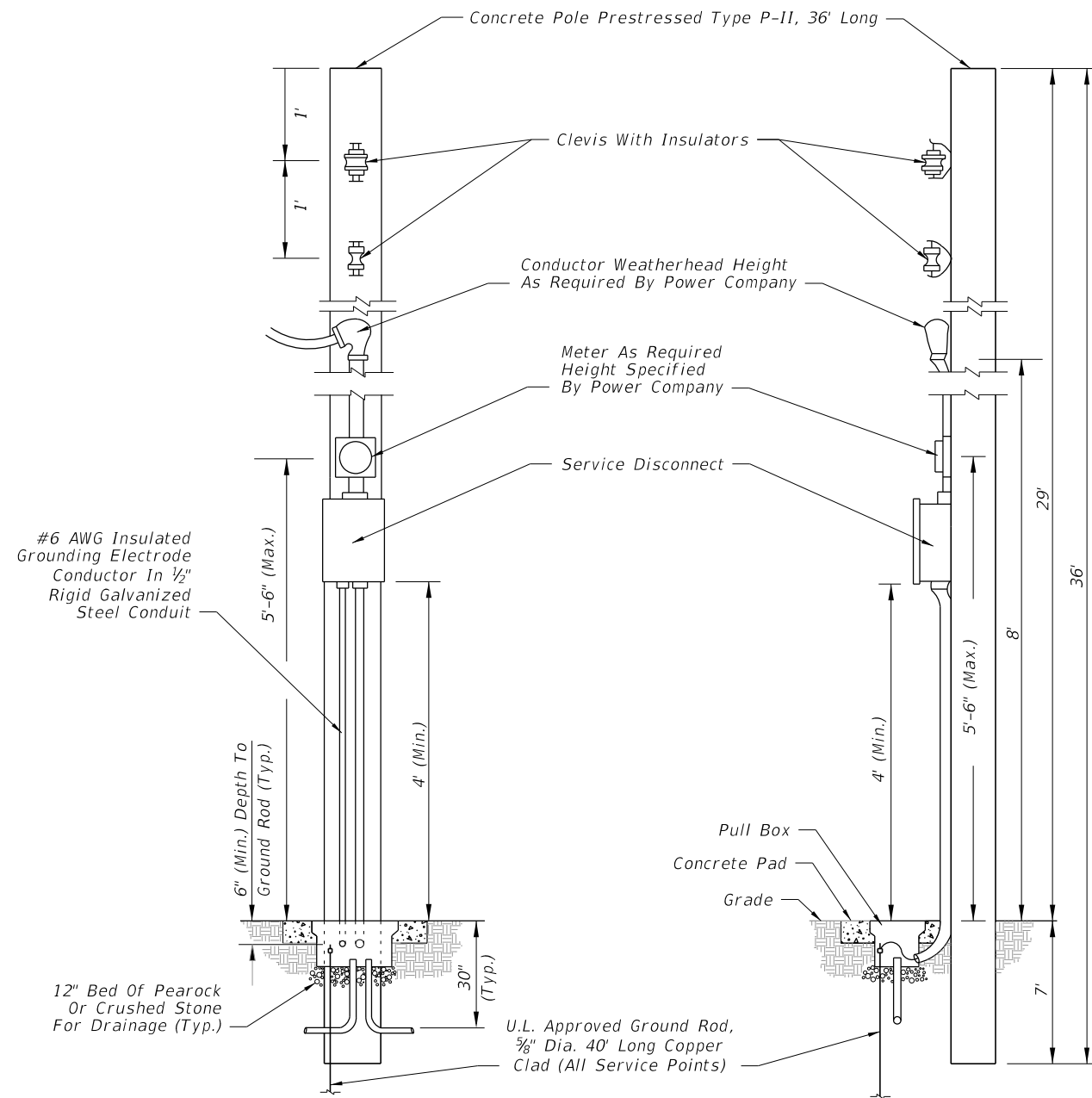

**DETAIL A
AERIAL FEED**

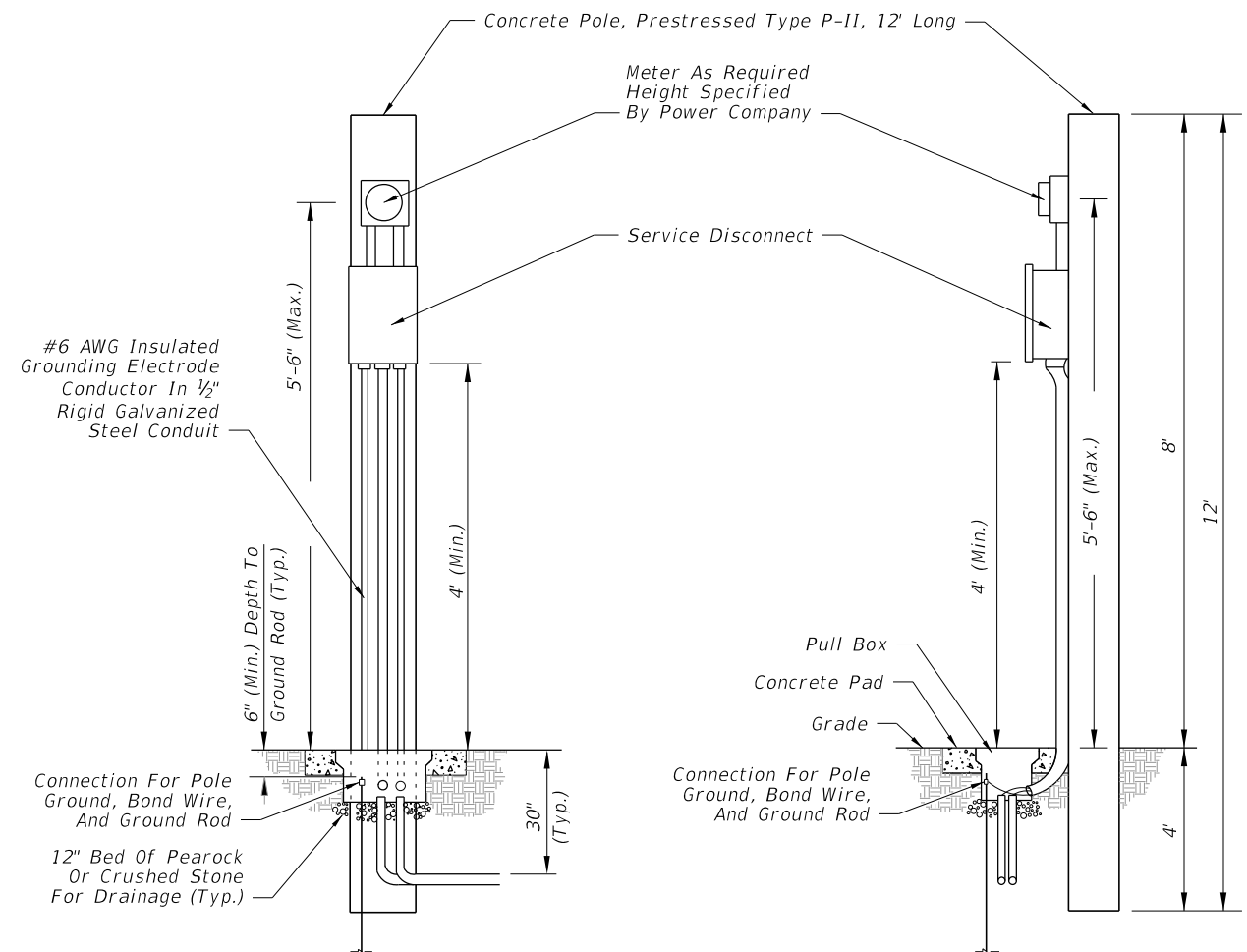

**DETAIL B
UNDERGROUND FEED**

10/14/2016 10:55:48 AM

LAST REVISION	01/01/16	DESCRIPTION:
---------------	----------	--------------

Keyed Notes:

1. 240/480V, Single Phase 3 Wire Electric Distribution Overhead Service Drop.
2. Service Feeder in Rigid Galvanized Steel Conduit.
3. Meter Socket by Contractor
4. Service Main Disconnect.
5. Lighting Control Panel Enclosure (NEMA 4X SST). Dimensions as Necessary for Equipment Inside. Ground Mounted Cabinet per Index 17736.
6. Concrete Riser Pole.
7. Weatherhead.
8. Electrical Panel. Number and Rating of Branch Circuit Breakers shall be as Indicated on Distribution Point Description on Lighting Plan Sheets.
9. Branch Circuit to Roadway Luminaires.
10. 5/8" Copper Clad Ground Rod, 40' Long.
11. #6 Insulated Copper Ground Wire. Bond the Service Neutral to Ground at Service Main Disconnect.
12. Fused Control Power Transformer 0.5 KVA, Single Phase, 480V Primary, 120V Secondary (Part of Lighting Contactor, Shown Outside for Clarity).
13. Lightning Arrester Mounted on Outside of Enclosure.
14. Lighting Control Panel Main Breaker.
15. 2 Pole Electrical Lighting Contactor.
16. Photo Electric Switch-120V Rated.
17. Hand-off Automatic Selector Switch (Part of Lighting Contactor, Shown Outside for Clarity).
18. Concrete Pad.
19. Underground Feeder Conduit.
20. Mount on Riser Pole.
21. Ground BUS.
22. NEMA 4X SST Ground Mounted Storage Cabinet with Two Shelves. Only Required for High Mast Lighting Systems.

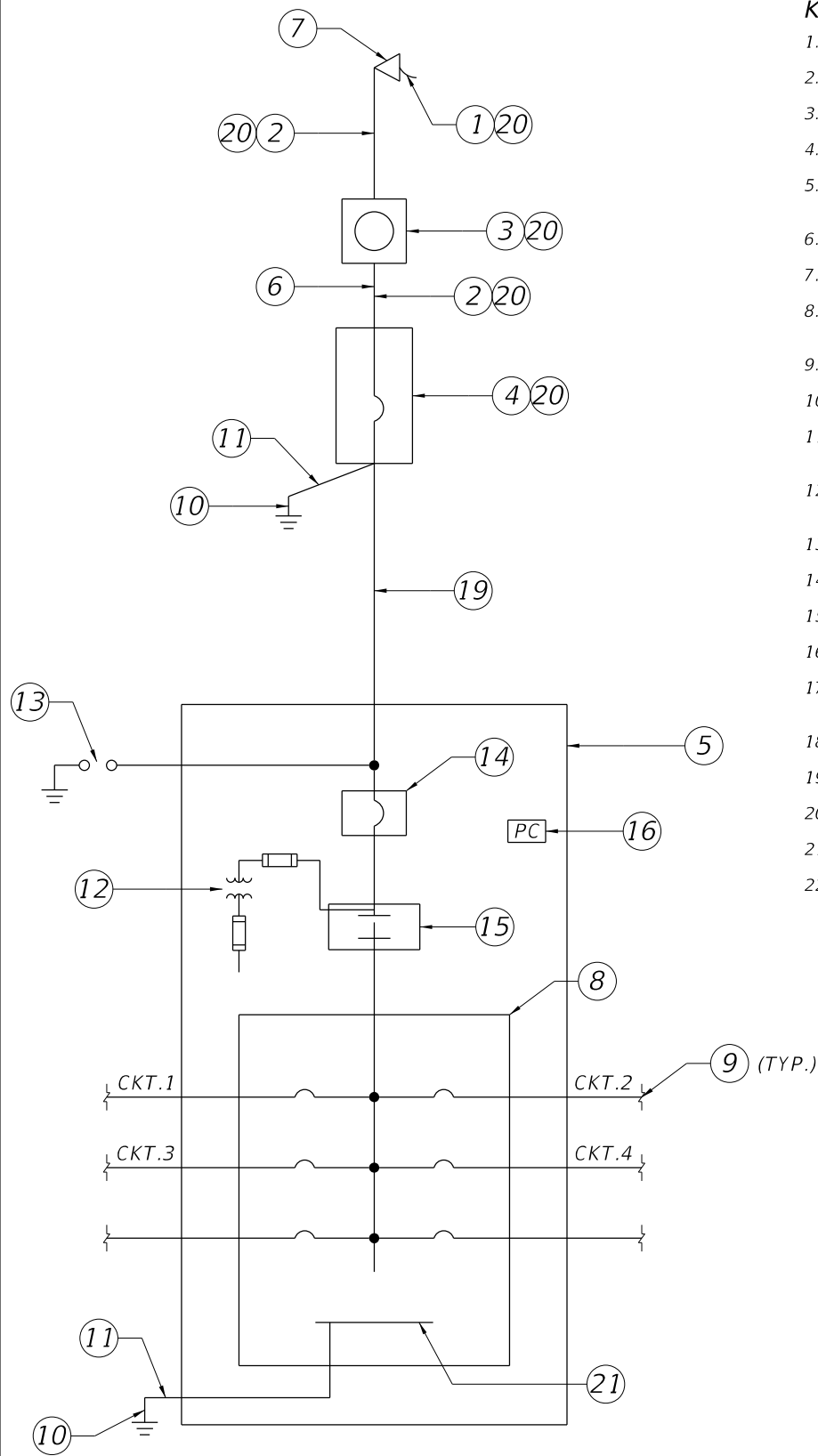

ONE LINE DIAGRAM DISTRIBUTION POINT

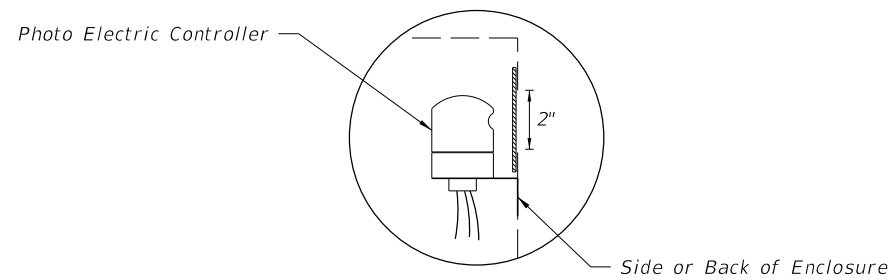

Cut a 2" hole in the side of the Lighting Control Panel enclosure for the operation and mounting of the Photo Electric controller. Use plexiglass and a clear silicone sealant to cover hole, install Photo Electric Controller.

PHOTO ELECTRIC CONTROLLER DETAIL

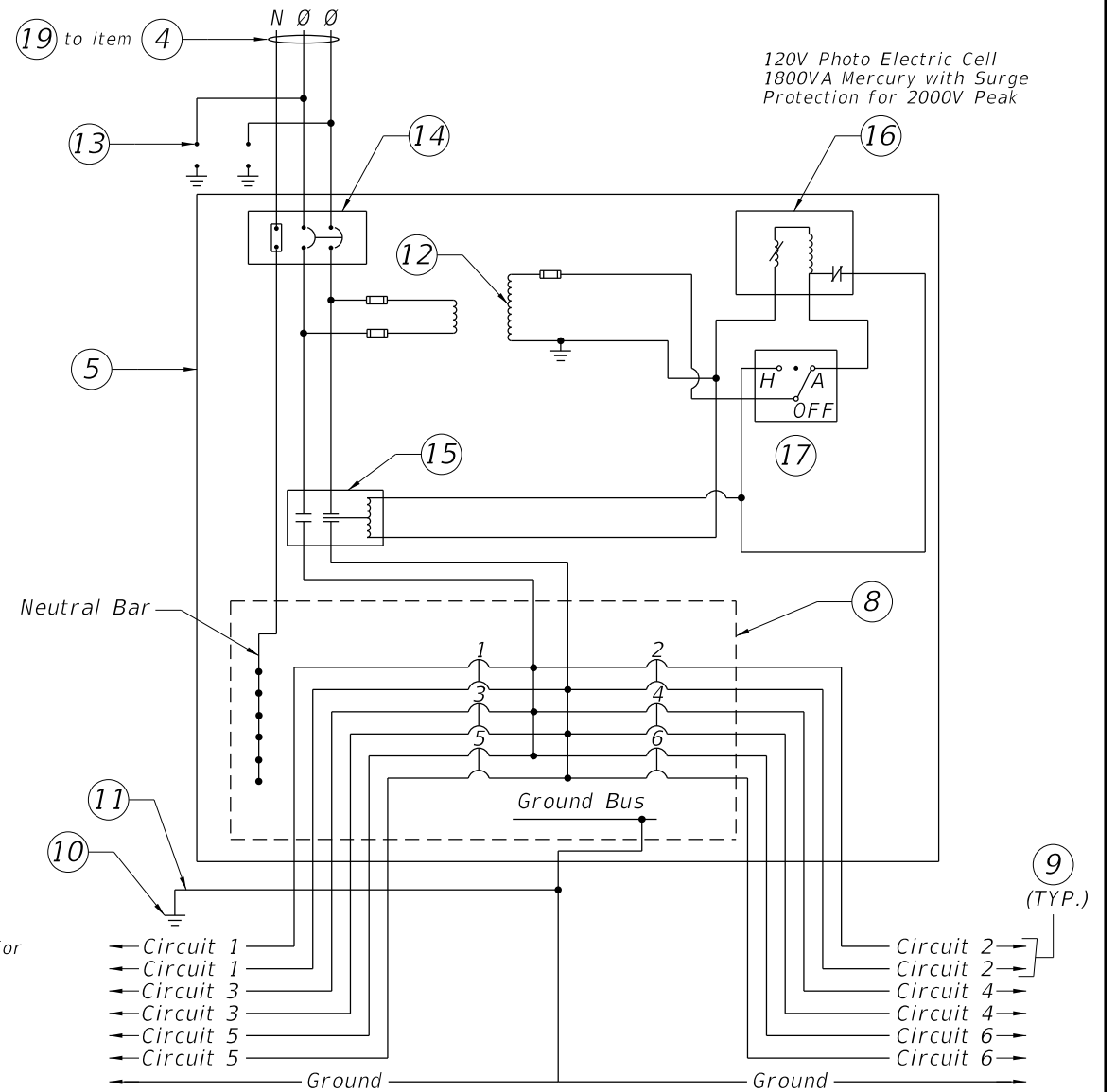

TYPICAL DISTRIBUTION POINT SCHEMATIC DETAIL

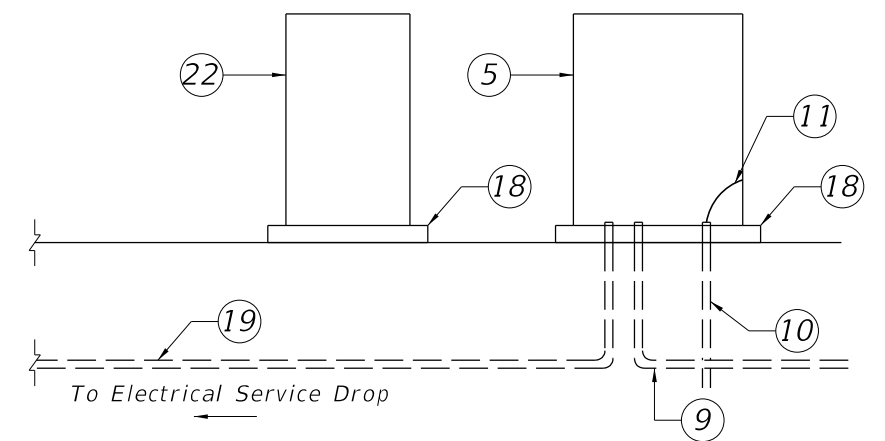

RISER DIAGRAM - TYPICAL DISTRIBUTION POINT

10/14/2016 10:55:50 AM

LAST REVISION 11/01/16	DESCRIPTION:
---------------------------	--------------