

PARTIAL PLAN OF RAILING

☐ Post Bolts and Match Line (Trailing End) (See Sheets 3 and 4)

☐ Post Bolts and Match Line (Approach End) (See Sheets 3 and 4)

6'-3" spacing (Typ. except as noted along Bridge, see Note 2)

1'-6" Min. for non skewed joints. For treatment of skewed Intermediate Deck Joints see Skew Detail Index No. 470, Sheet 2 (Typ.)

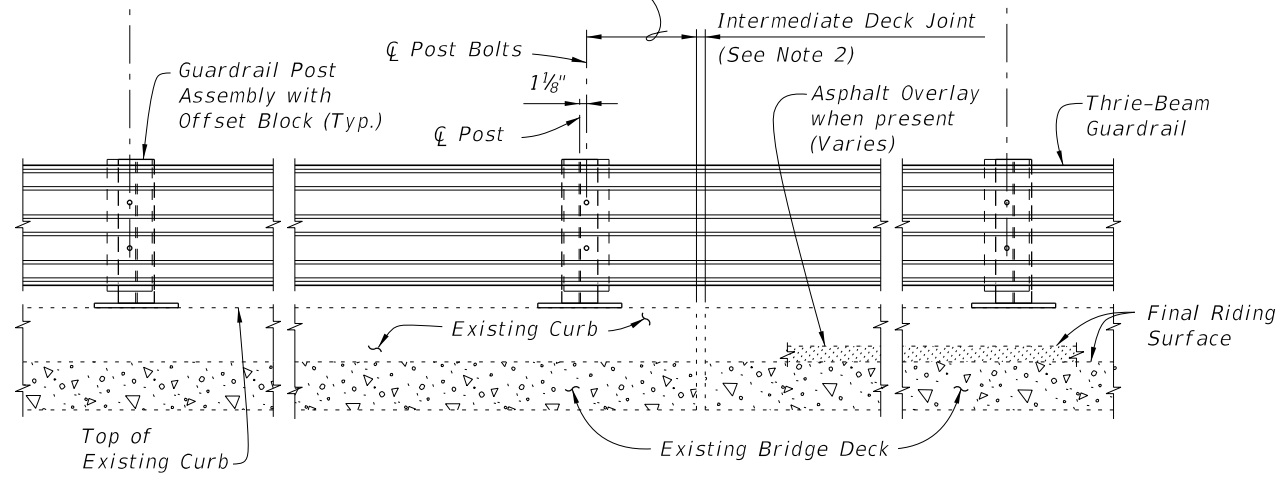

PARTIAL ELEVATION OF INSIDE FACE OF RAILING
(Existing Traffic Railing not shown for clarity)

==== TYPICAL TREATMENT OF RAILING ALONG BRIDGE ====

NOTES:

1. On approach end provide Index No. 402 (as shown) or other site specific treatment, see Roadway Plans. For treatment of trailing end see Roadway Plans.
2. Actual joint dimension and orientation vary. For Intermediate Deck Joints use the Modified Post Spacing at Intermediate Deck Joints Detail, Index No. 470, Sheet 2, as required.
3. Areas where existing structure has been removed shall match adjoining areas and shall be finished flat by grouting or grinding as required. Exposed existing reinforcing steel shall be burned off 1" below existing concrete and grouted over.

CROSS REFERENCES:

For Section A-A see Sheet 2.
For Traffic Railing Notes and Details see Index No. 470.

10/26/2016 8:18:08 AM

LAST REVISION 01/01/08	REVISION	DESCRIPTION:	 FY 2017-18 DESIGN STANDARDS	TRAFFIC RAILING - (THRIE-BEAM RETROFIT) WIDE STRONG CURB TYPE 1	INDEX NO. 472	SHEET NO. 1 of 4
---------------------------	----------	--------------	--	--	-------------------------	----------------------------

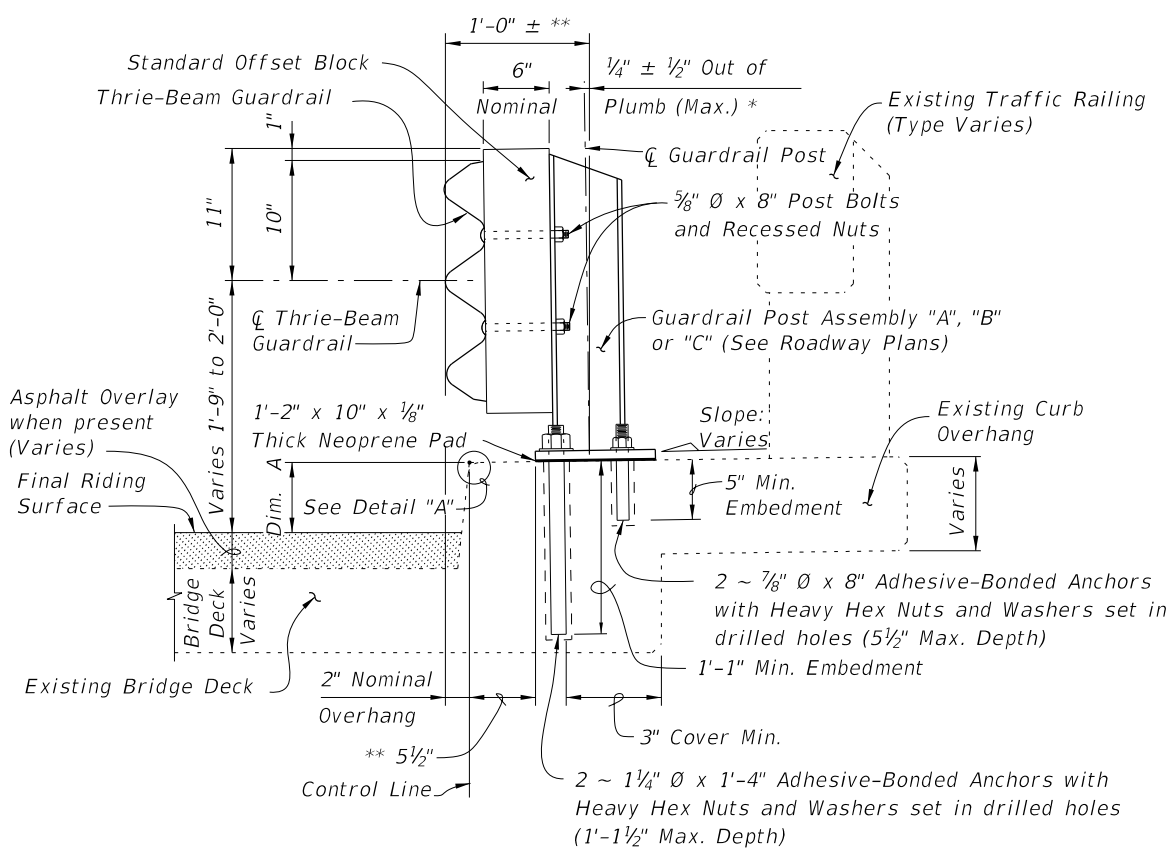

SECTION A-A
TYPICAL SECTION THRU RAILING ON BRIDGE DECK

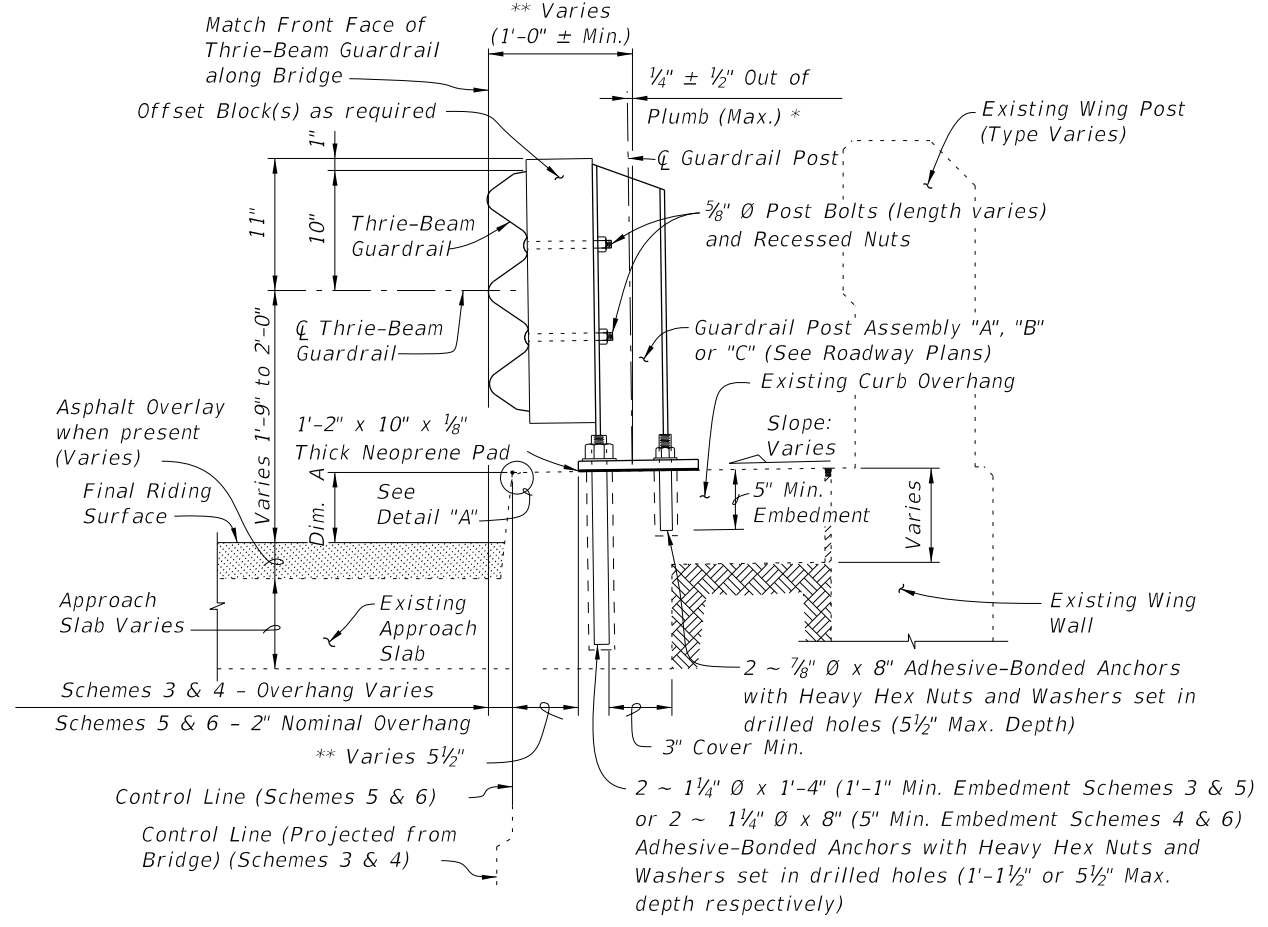

SECTION B-B
TYPICAL SECTION THRU RAILING ALONG APPROACH SLAB
(SCHEMES 5 AND 6 SHOWN, SCHEMES 3 AND 4 SIMILAR)

BILL OF REINFORCING STEEL			BAR BENDING DIAGRAMS	
MARK	SIZE	LENGTH		
D	4	3'-7"		
L	4	4'-1"		
M	4	2'-8"		

NOTE: All bar dimensions are out to out.

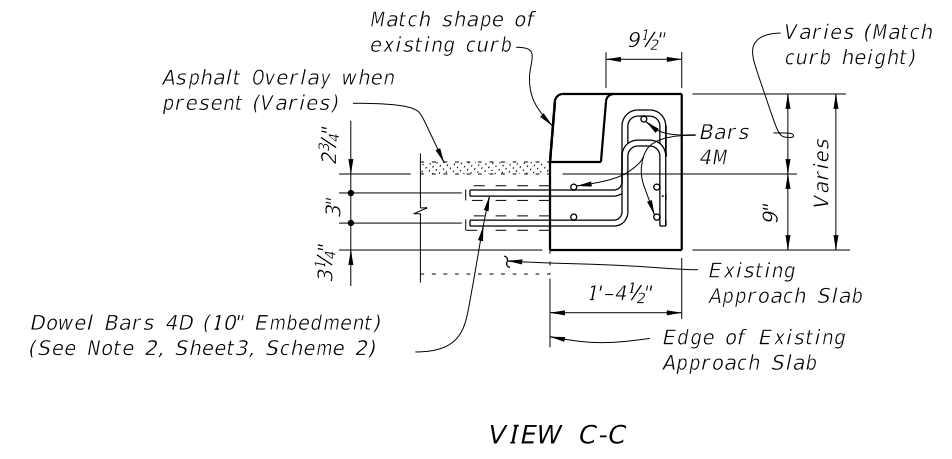
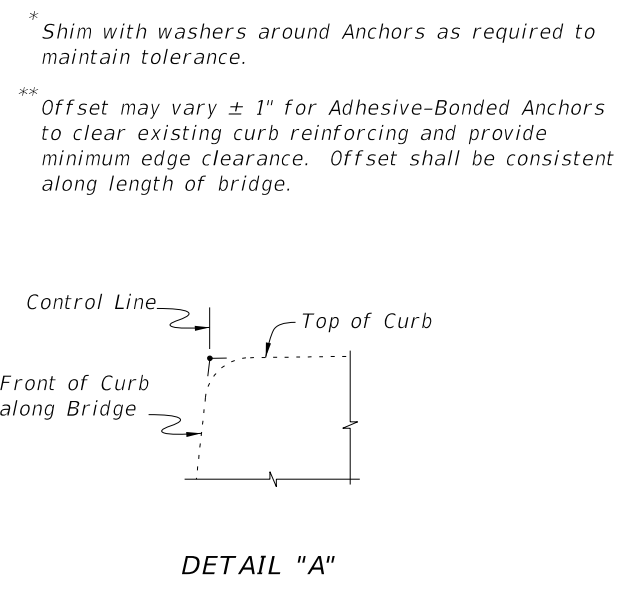

CROSS REFERENCES:
 For location of Section A-A see Sheets 1, 3 & 4.
 For location of Section B-B see Sheet 4.
 For location of View C-C see Sheet 3.
 For application of Dim. A see Post Dimension Table on Index 470, Sheet 3.

10/26/2016 8:18:10 AM

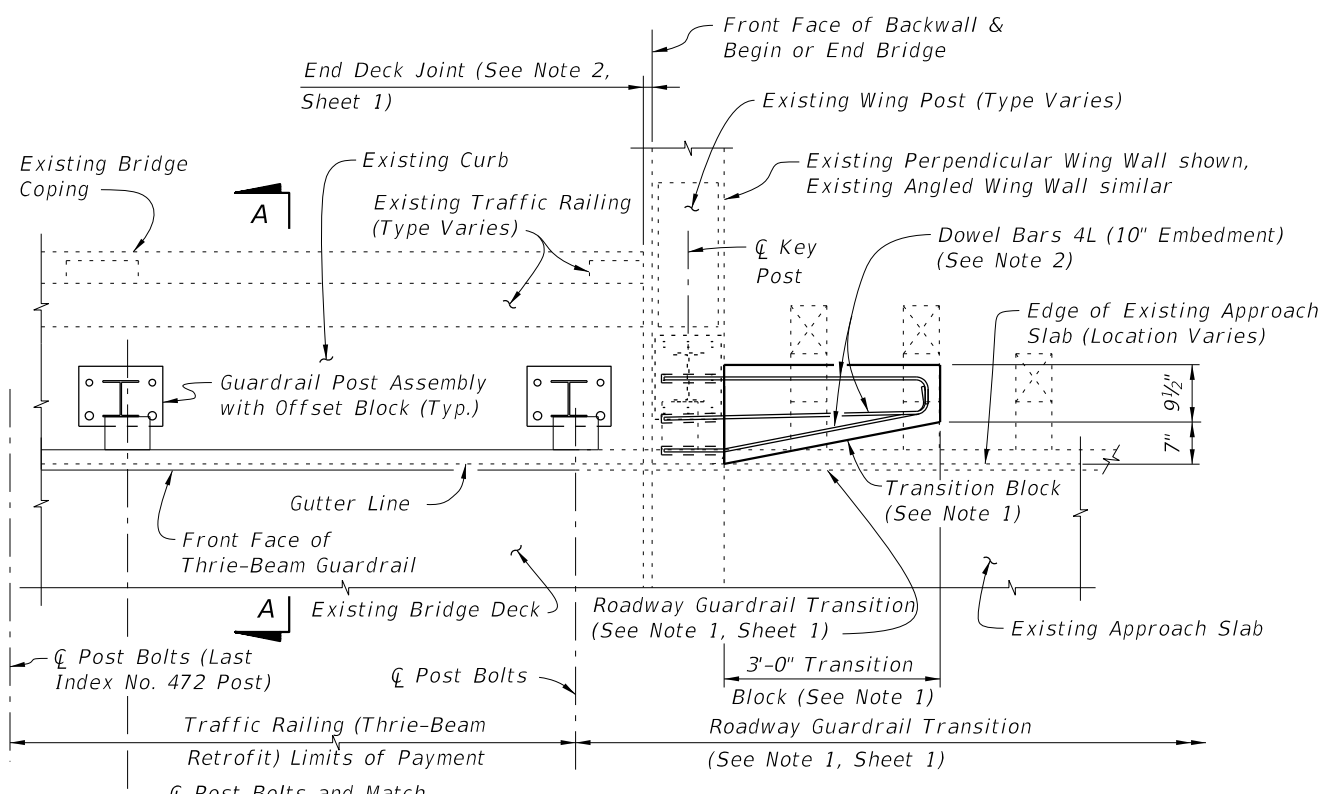

PARTIAL PLAN OF RAILING

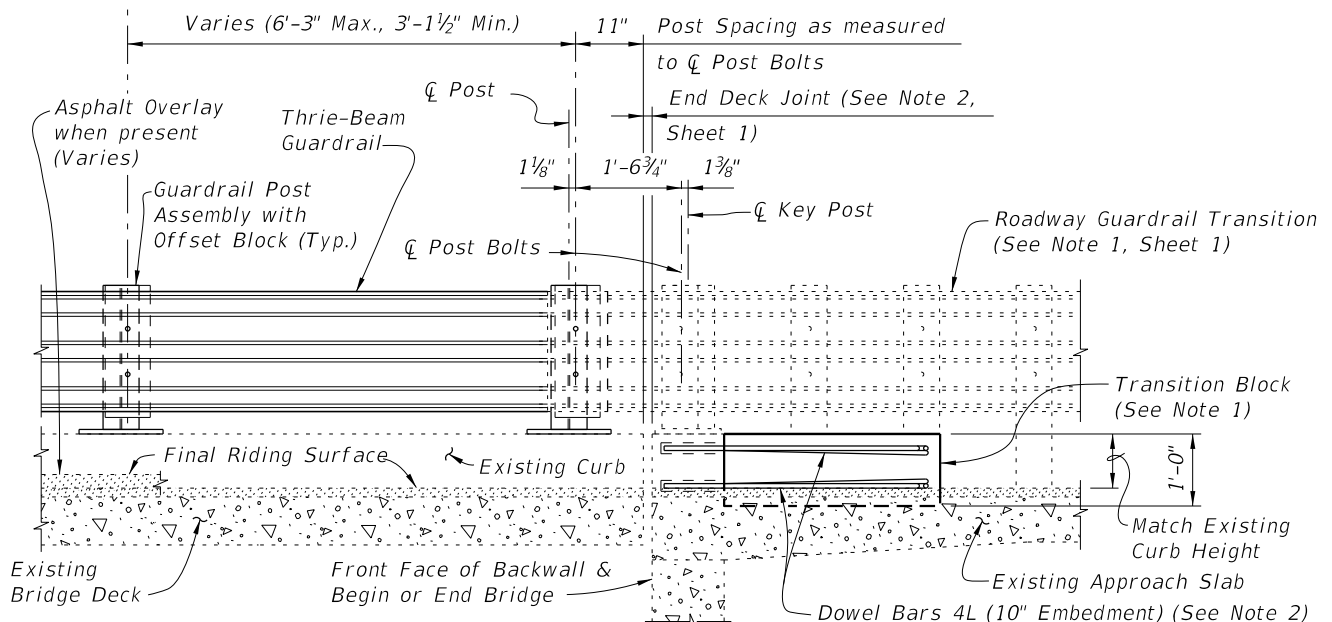

PARTIAL ELEVATION OF INSIDE FACE OF RAILING
(Existing Wing Post and Traffic Railing not shown for clarity)

SCHEME 1
RAILING END TREATMENT FOR PERPENDICULAR OR ANGLED WING WALLS

- SCHEME 1 NOTES:**
1. Provide Transition Block (as shown) or Curb if existing Approach Slab does not have a curb, see Roadway Plans. Shape and height of Transition Block or Curb shall match existing bridge curb. Transition Block may be omitted on trailing ends with no opposing traffic.
 2. Field bend Dowel Bars 4L within Transition Block as required to maintain 2" top and side clearance and 3" bottom clearance.

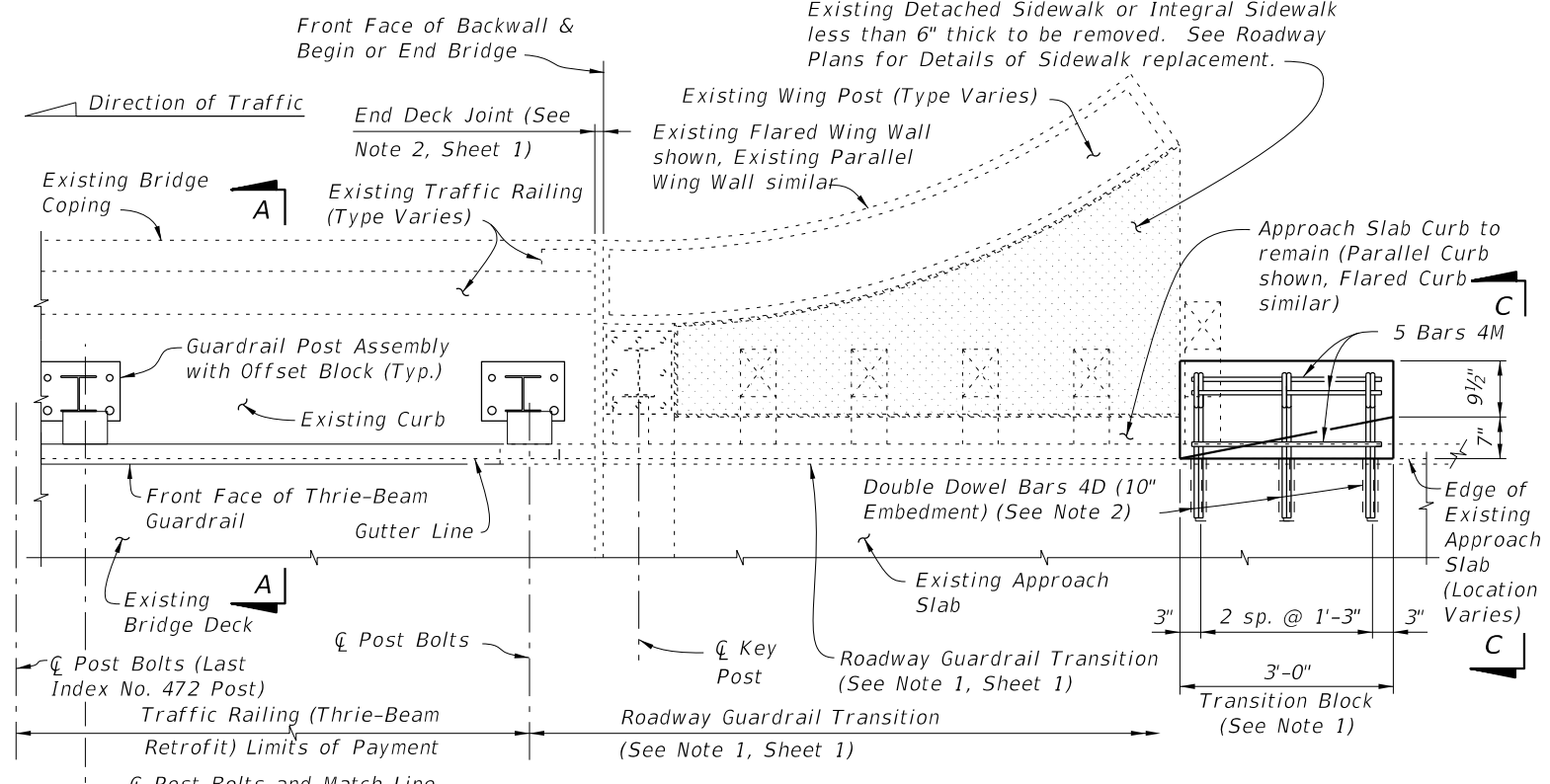

PARTIAL PLAN OF RAILING

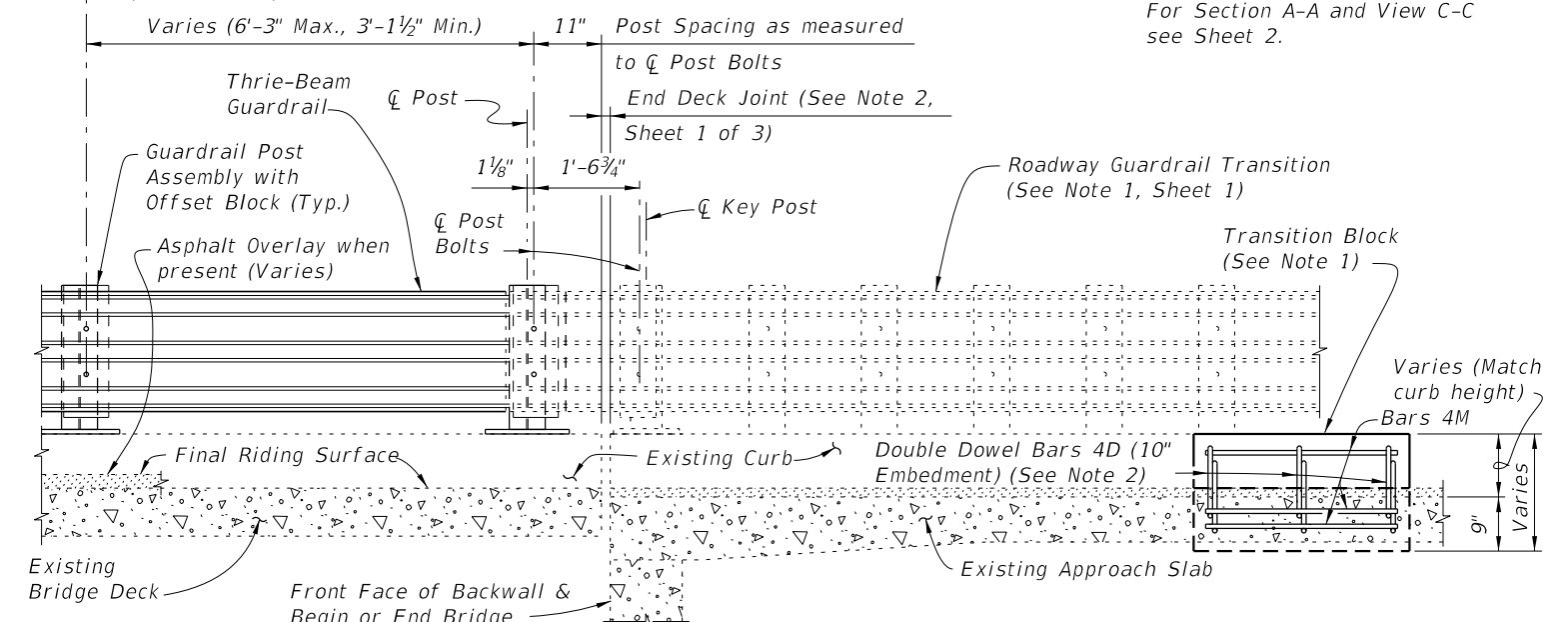

PARTIAL ELEVATION OF INSIDE FACE OF RAILING
(Existing Wing Post and Traffic Railing not shown for clarity)

SCHEME 2
RAILING END TREATMENT FOR PARALLEL OR FLARED CURBS WITH DETACHED SIDEWALKS OR INTEGRAL SIDEWALKS LESS THAN 6" THICK

- SCHEME 2 NOTES:**
1. Provide Transition Block (as shown) or Curb if existing Approach Slab Curb does not extend to end of Approach Slab. Shape and height of Transition Block or Curb shall match existing bridge curb. Transition Block may be omitted on trailing ends with no opposing traffic and on bridges with flared Approach Slab Curbs.
 2. Field bend or tilt Dowel Bars 4D and Bars 4M within Transition Block as required to maintain 2" top and side clearance and 3" bottom clearance.

CROSS REFERENCES:
For Section A-A and View C-C see Sheet 2.

10/26/2016 8:18:13 AM

LAST REVISION 01/01/08	DESCRIPTION:	FY 2017-18 DESIGN STANDARDS	TRAFFIC RAILING - (THRIE-BEAM RETROFIT) WIDE STRONG CURB TYPE 1	INDEX NO. 472	SHEET NO. 3 of 4
---------------------------	--------------	--	--	-------------------------	----------------------------

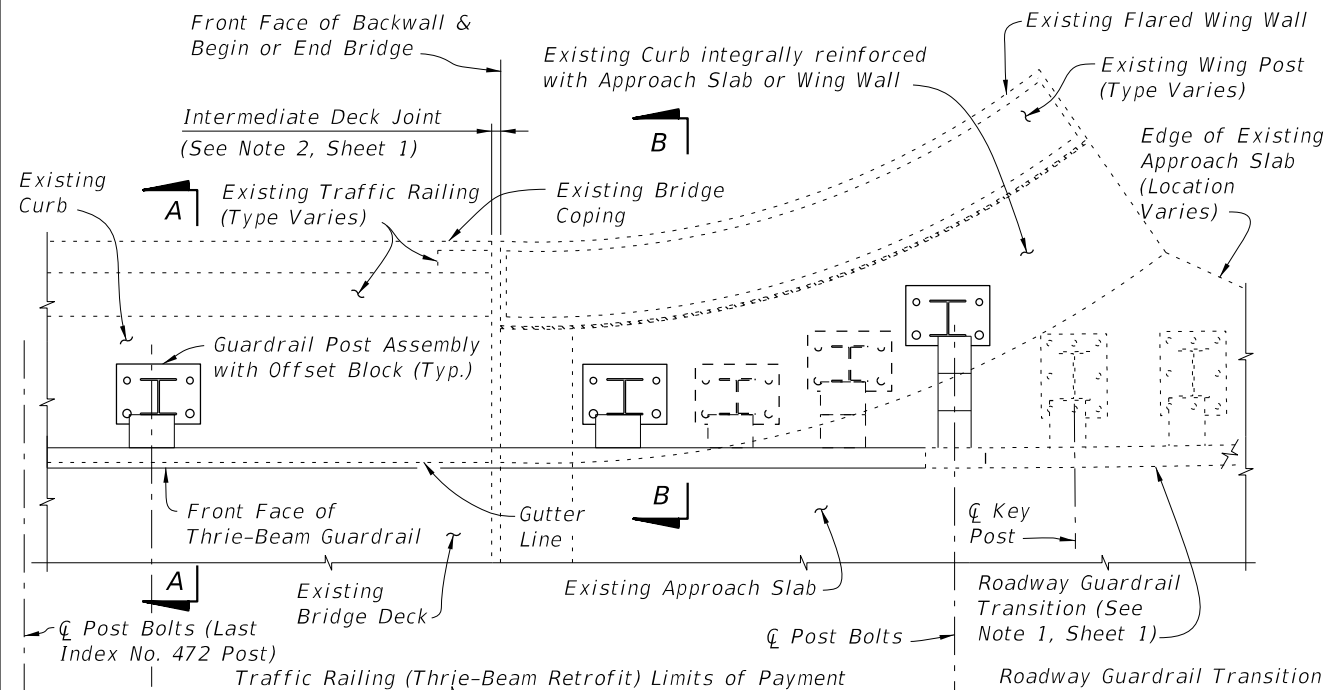

PARTIAL PLAN OF RAILING

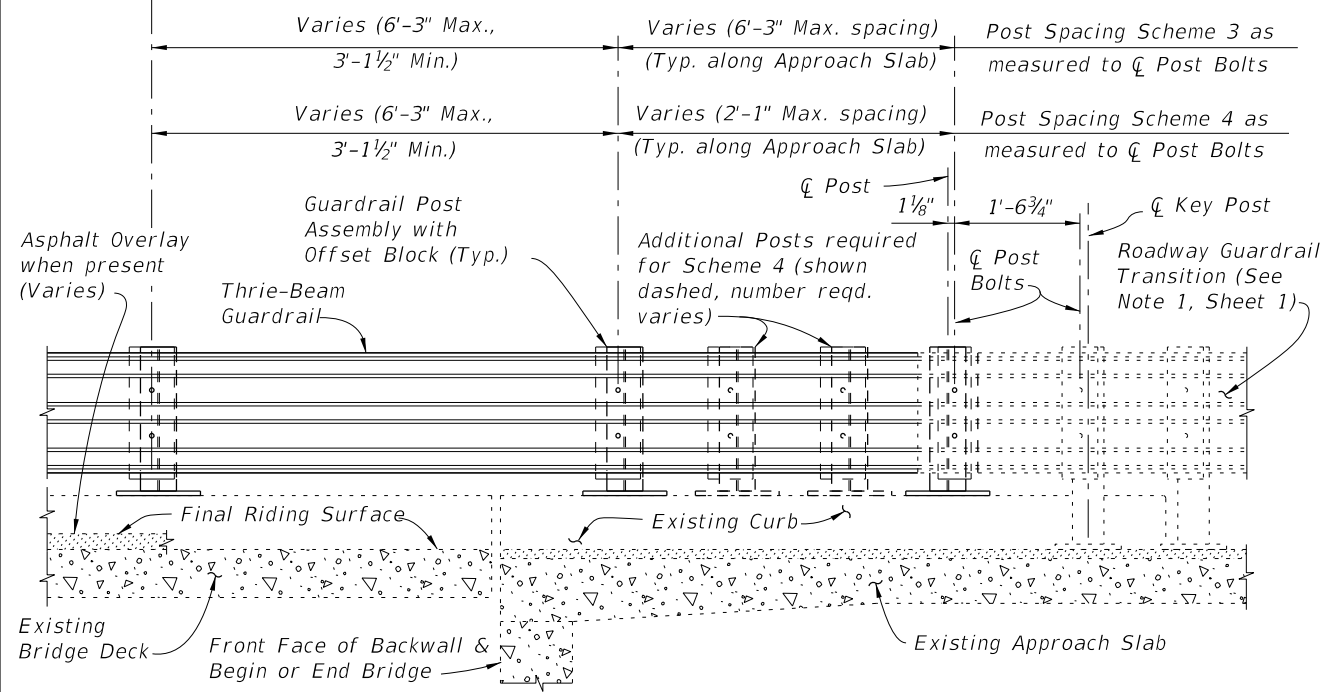

PARTIAL ELEVATION OF INSIDE FACE OF RAILING
(Existing Wing Post and Traffic Railing not shown for clarity)

SCHMES 3 AND 4
RAILING END TREATMENT FOR FLARED INTEGRAL CURBS

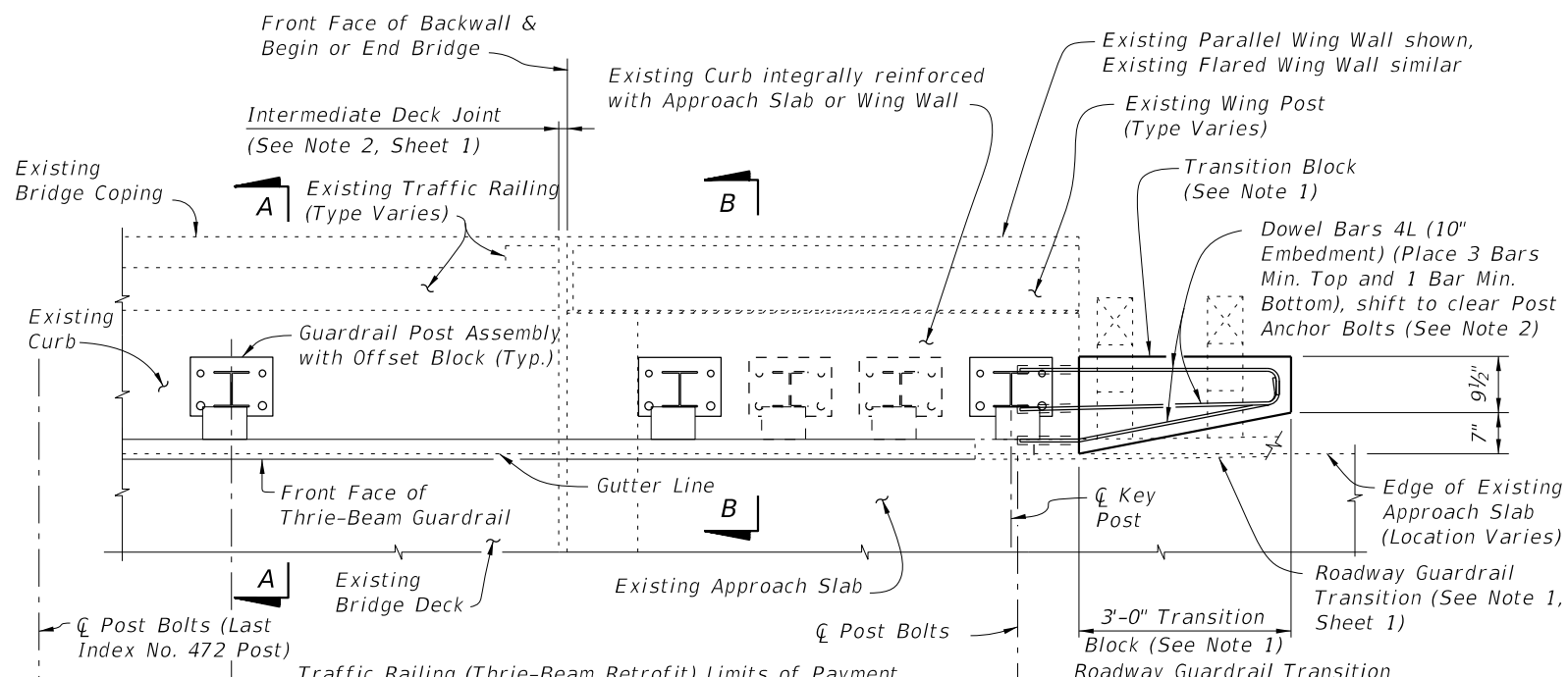

PARTIAL PLAN OF RAILING

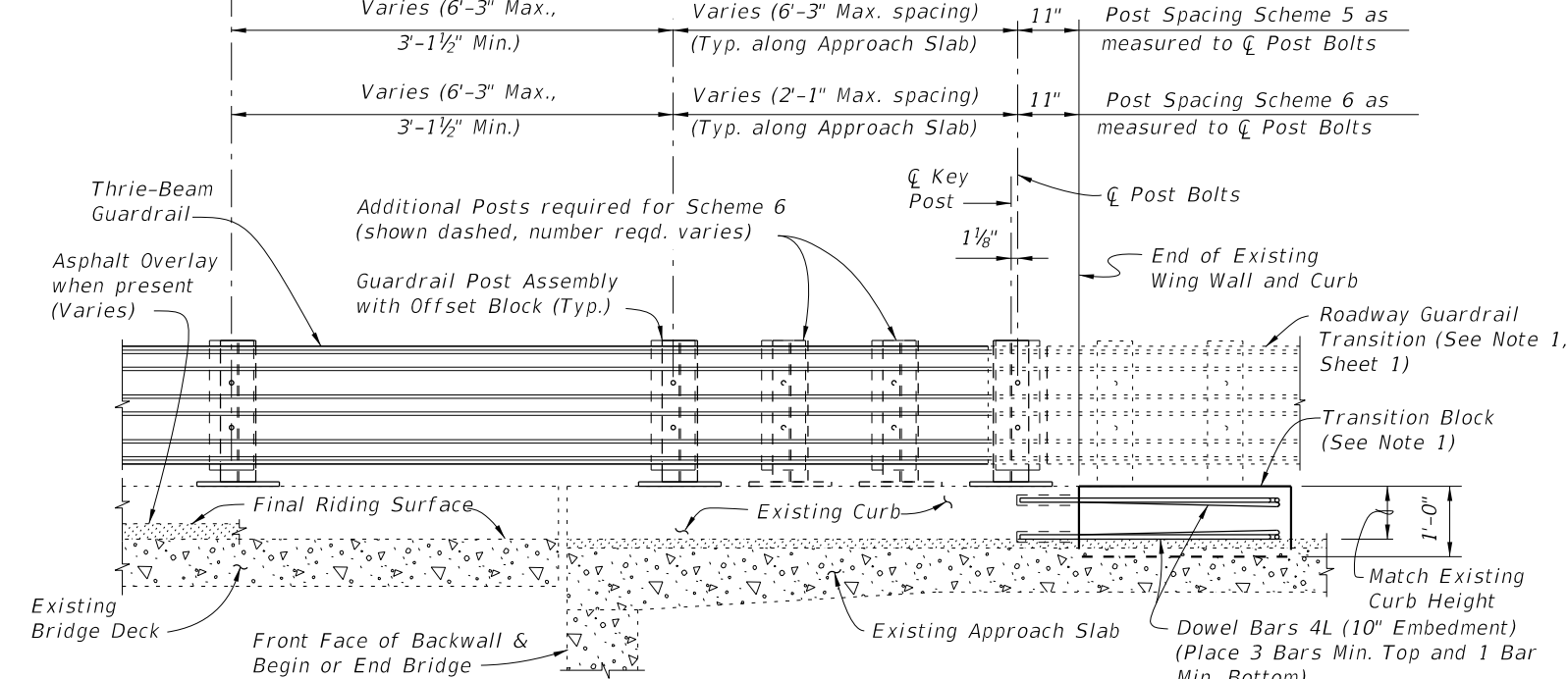

PARTIAL ELEVATION OF INSIDE FACE OF RAILING
(Existing Wing Post and Traffic Railing not shown for clarity)

SCHMES 5 AND 6
RAILING END TREATMENT FOR PARALLEL INTEGRAL CURBS

SCHMES 5 AND 6 NOTES:

1. Provide Transition Block (as shown) or Curb if existing Approach Slab Curb does not extend to end of Approach Slab. Shape and height of Transition Block or Curb shall match existing bridge curb. Transition Block may be omitted on trailing ends with no opposing traffic.
2. Field bend Dowel Bars 4L within Transition Block as required to maintain 2" top and side clearance and 3" bottom clearance.

10/26/2016 8:18:15 AM

LAST REVISION	DESCRIPTION:
01/01/08	