

## Index 304 Detectable Warnings and Sidewalk Curb Ramps (Rev. 11/16)

### Design Criteria

*Plans Preparation Manual (PPM)* Volume 1, Chapter 8, Accessibility Considerations, Latest Edition; *Americans with Disabilities Act Standards for Transportation Facilities*, ADA 2006; *Public Rights-of-Way Accessibility Guidelines*, PROWAG 2011; and the *Florida Intersection Design Guide*, FIDG Latest Edition.

### Design Assumptions and Limitations

Refer to the *PPM* Volume 1, Chapter 8 for limitations relative to sidewalk accessibility conditions.

Sidewalk Curb Ramps are designed based on accessibility guidelines from the *Americans with Disabilities Act Standards for Transportation Facilities* 2006.

Sidewalk Curb Ramp preferences for *Design Standard*, Index 304 are taken from the *Public Rights-of-Way Accessibility Guidelines* (PROWAG) 2011.

Alpha-identifications have been provided in the Index for the various curb ramp options (e.g. CR-A, CR-B, etc.) to facilitate ease of callouts in the Plans.

- Curb Ramps CR-A, CR-B & CR-C are for use where ramp and landing depths are not restricted.
- Curb Ramps CR-D, CR-E, CR-F, CR-G and CR-H are for linear pedestrian traffic.
- Curb Ramps CR-K and CR-L are for use where ramp and landing depths are restricted.

Limitations on Sidewalk Curb Ramp designs: When proposed sidewalk curb ramps cannot be designed within existing accessibility guidelines, then a project specific design is required to be in accordance with ADA requirements. When compliance with ADA curb ramp requirements is determined to be technically infeasible (i.e. no engineering solution is available), documentation as a Design Variation is required. This may occur where existing right of way is inadequate and where conflicts may occur with existing features which cannot be feasibly relocated or adjusted (drainage inlets, signal poles, pull and junction boxes, etc.).

Geometric designs (typical radii for 90 degree curb returns) for the table of detectable warnings of turning roadways is taken from the *Florida Intersection Design Guide*.

Limitations on detectable warning surfaces: The Surface Area of Detectable Warnings is provided as Table 1. These typical areas are provided for the 10 standard curb ramp types (see all alpha-identifications) and 2 flush shoulder options. Quantities for the total area were generated based on typical radii for 90 degree curb returns. The total area of detectable warning quantities are intended to aid the designer in quantifying detectable warning surfaces for typical sidewalk curb ramp applications. For detectable warnings total area calculations see Design Aids below.

## Plan Content Requirements

Summary Boxes:

See **Basis of Estimates (BOE)** Chapter 8 for Summary of Sidewalk and Detectable Warnings requirements.

Roadway Plan Views:

1. Location (Station)
2. Side (either Left, Right or Median)
3. Sidewalk Curb Ramp alpha-identification

## Payment

Refer to the Basis of Estimates and Standard Specifications for Road and Bridge Construction for additional information on payment, pay item use and compensation.

Item number	Item description	Unit Measure
520-1-	Concrete Curb and Gutter	LF
522-1-	Concrete Sidewalk and Driveways	SY
527-2-	Detectable Warnings	SF

Detectable Warnings and Sidewalk Curb Ramps are paid as follows:

Curb transitions and reconstructed curbs are paid under the contract unit price of Concrete Curb and Gutter, LF.

Sidewalk curb ramps, reconstructed sidewalks, walk around sidewalks, sidewalk landings, and sidewalk curb are paid under the contract unit price for Concrete Sidewalk and Driveways, SY.

The cost of furnishing and installing detectable warnings for new construction or retrofit and all incidental items are included in the pay item for Detectable Warnings, SF.

**Table 1 Surface Area of Detectable Warnings**

<b>Curb Ramp Type</b>	<b>Curb Radius (ft)</b>	<b>Total Area (sf)</b>
CR-A	N/A	8
CR-B	N/A	8
CR-C	N/A	8
CR-D	25	11
CR-E	N/A	8
CR-F	10	9
	20	11
	25	13
	30	14
CR-G	10	10
	20	11
	25	12
	30	14
CR-H	20	8
	25	8
	30	8
CR-K	N/A	8
CR-L	10	18
	15	13
Flush Shoulder Option A	10	11
	20	14
	25	15
	30	17
	40	19
	50	21
Flush Shoulder Option B	10	10
	20	10
	25	10

## Design Aids

Detectable Warnings Total Area Calculations:

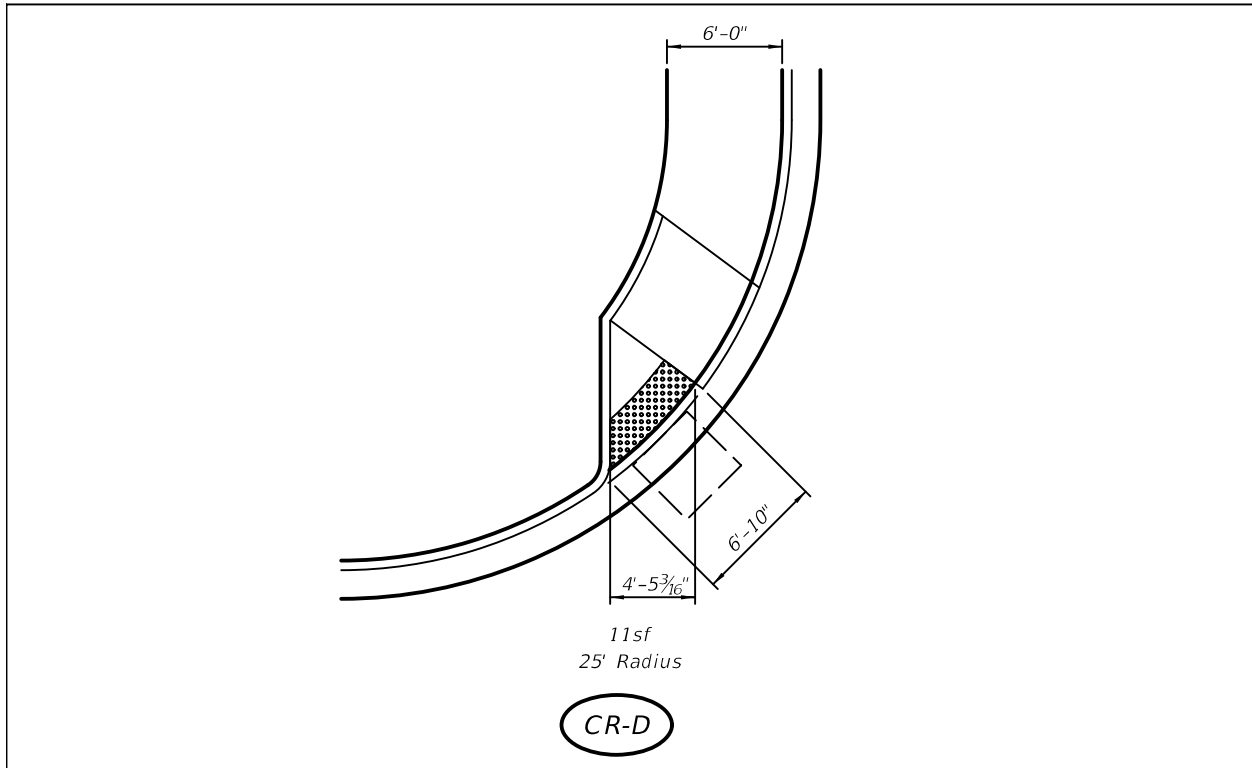

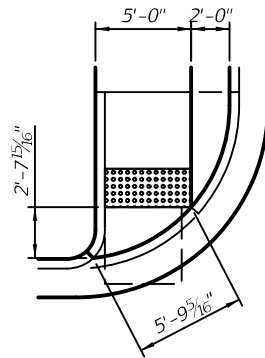

9sf  
10' Radius

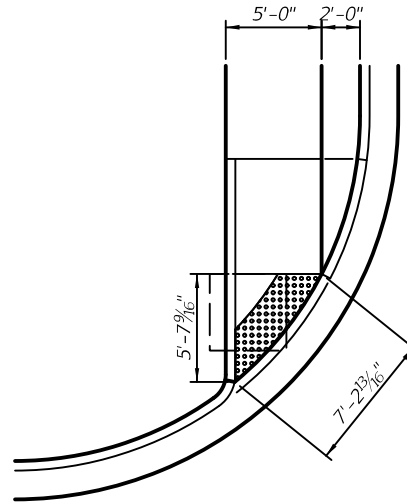

11sf  
20' Radius

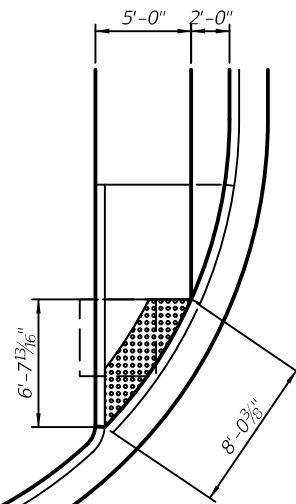

13sf  
25' Radius

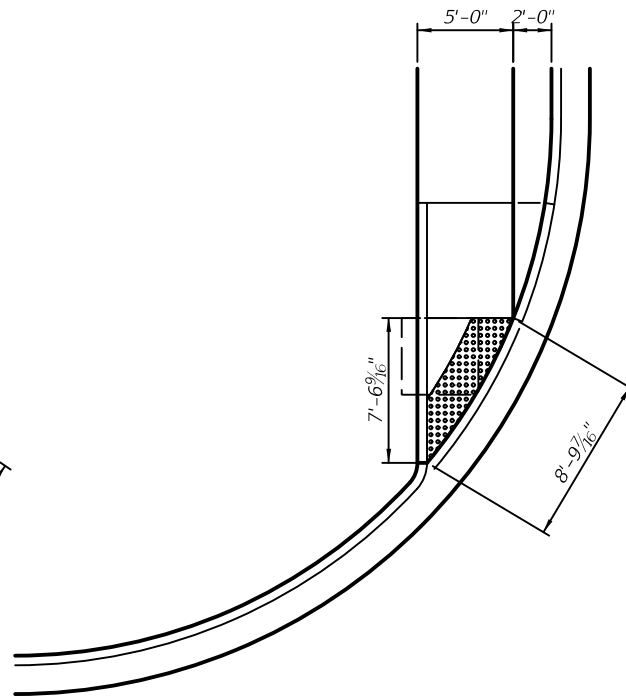

14sf  
30' Radius

CR-F

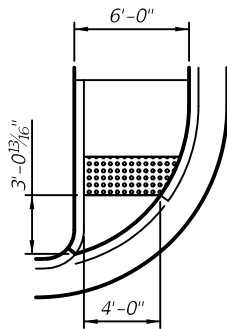

10sf  
10' Radius

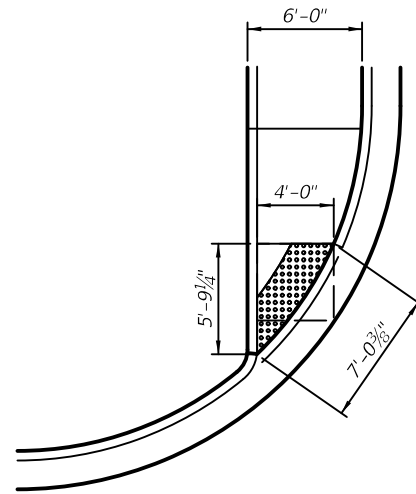

11sf  
20' Radius

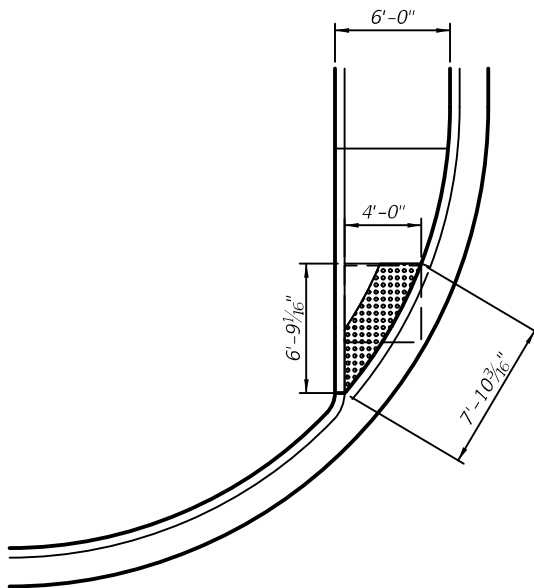

12sf  
25' Radius

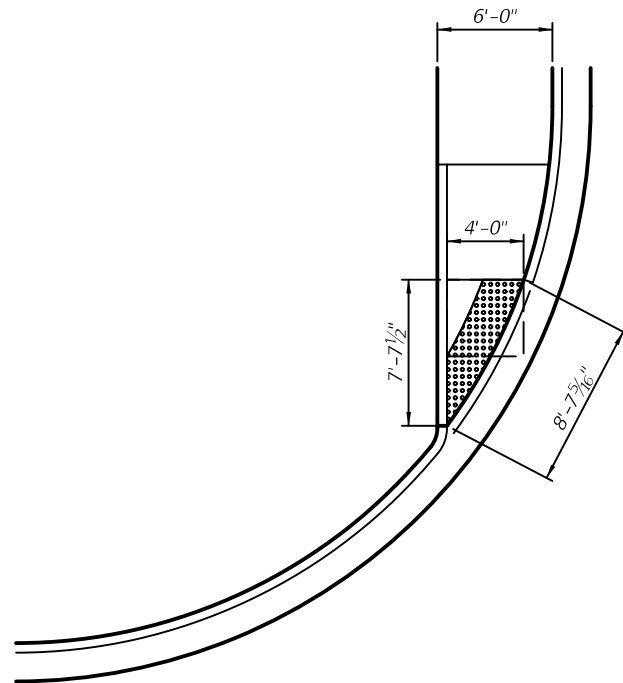

14sf  
30' Radius

CR-G

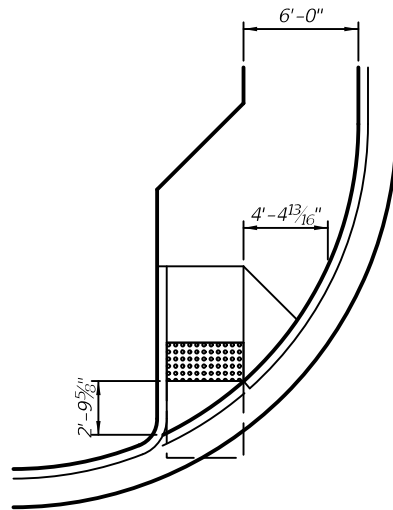

8sf  
20' Radius

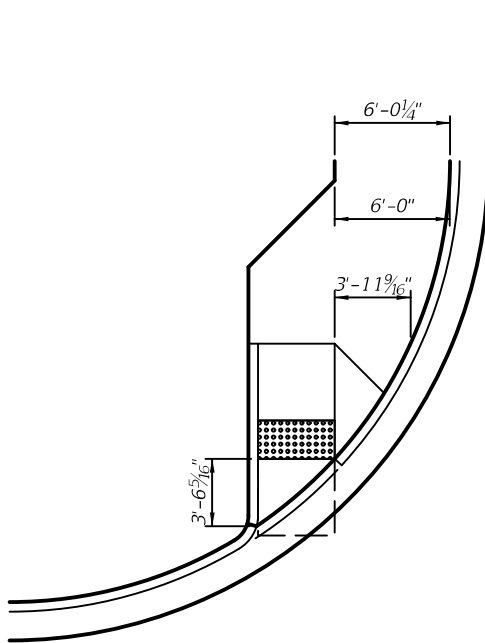

8sf  
25' Radius

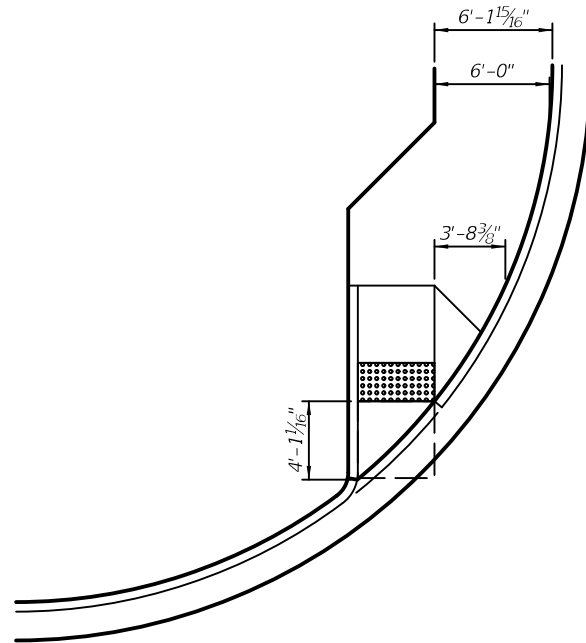

8sf  
30' Radius

CR-H

