

ELEVATION

\*\* See Note No. 4 on Index No. 22601

ALTERNATE STRAND PATTERNS

- 12 ~ 0.6" Ø, CFRP 7-Strand, at 34 kips
- 12 ~ 1/2" Ø, CFRP Single-Strand, at 33 kips

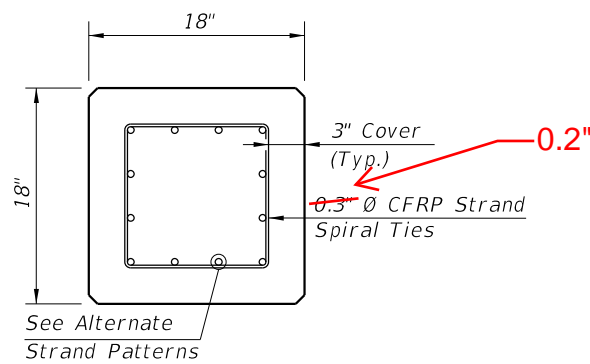

SECTION A-A

NOTES:

- Work this Index with Index 22600 - Notes and Details for Square CFRP & SS Prestressed Concrete Piles and Index 22601 - Square CFRP & SS Prestressed Concrete Pile Splices.
- Any of the given Strand Patterns may be utilized. The strands shall be located as follows:  
Place one strand at each corner and place the remaining strands equally spaced between the corner strands. The total strand pattern shall be concentric with the nominal concrete section of the pile.

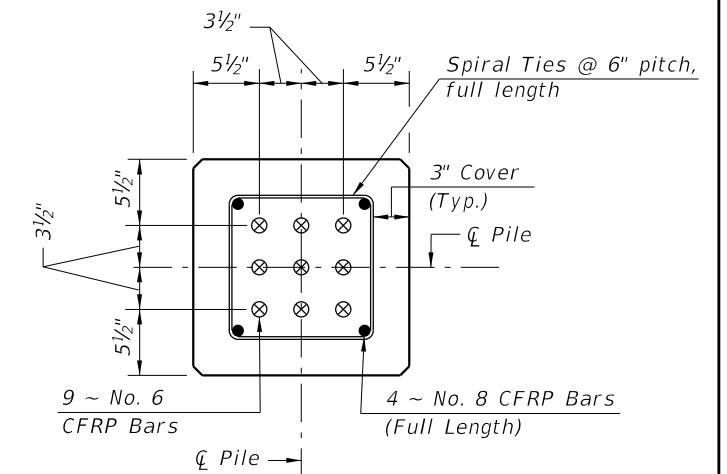

SECTION D-D

(See Nondrivable Unforeseen Reinforced Precast Pile Build-Up Detail)

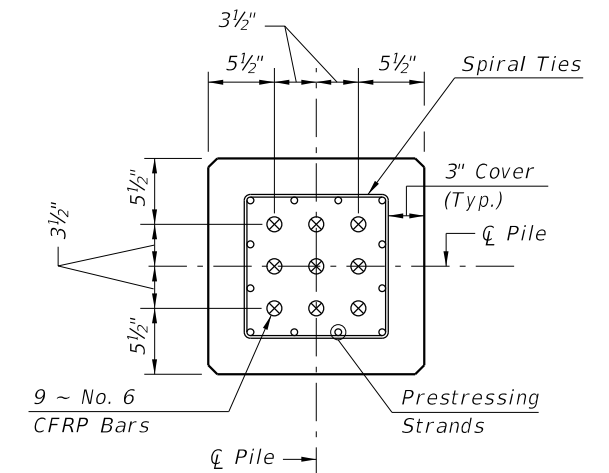

SECTION E-E

(See Drivable Prestressed Precast Splice Detail)

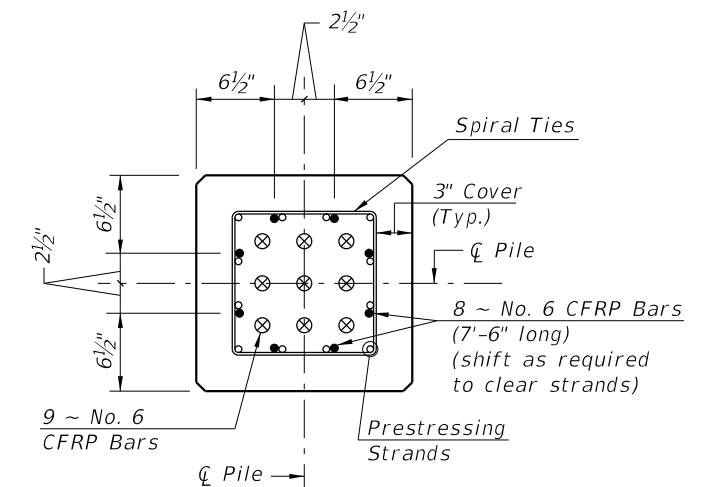

SECTION F-F

(See Drivable Preplanned Prestressed Precast Splice Detail)

CFRP PILE SPLICE REINFORCEMENT DETAILS

CFRP PRESTRESSED PILE DETAILS

10/26/2016 9:22:17 AM

LAST REVISION 01/01/16	DESCRIPTION:	FDOT FY 2017-18 DESIGN STANDARDS	18" SQUARE CFRP & SS PRESTRESSED CONCRETE PILE	INDEX NO. 22618	SHEET NO. 1 of 2
---------------------------	--------------	--	---	--------------------	---------------------