

\* These dimensions are measured perpendicular to the end of beam

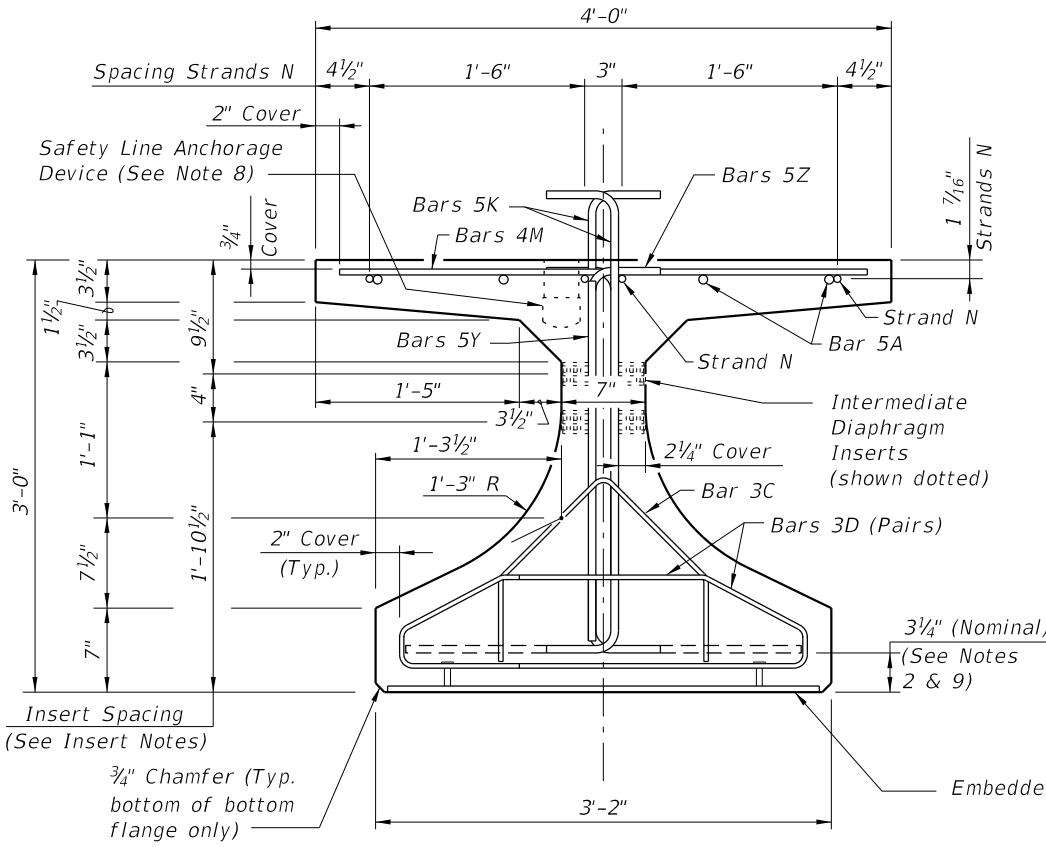

END VIEW

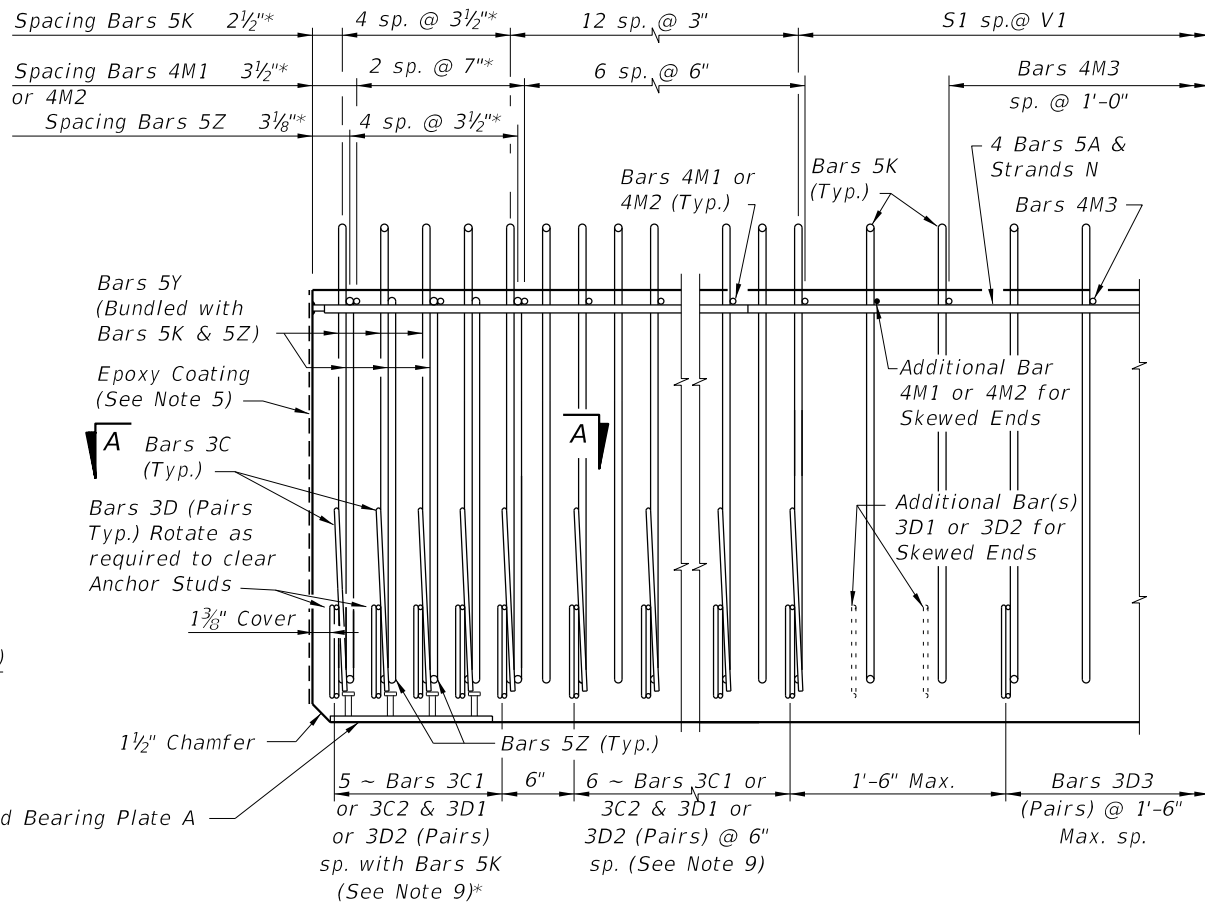

ELEVATION AT END OF BEAM (Flanges Not Shown For Clarity) (End 1 Shown, End 2 Similar)

CONVENTIONAL REINFORCING BAR BENDING DETAILS

BILL OF REINFORCING STEEL				
MARK	NOTE NUMBERS	SIZE	NUMBER REQUIRED	LENGTH (NOTE 1)
A	—	5	8	16'-0"
C1	9, 10 & 11	3	11 (End 1)	Varies
C2	9, 10 & 11	3	11 (End 2)	Varies
D1	9, 10, 11 & 14	3	22 (End 1)	Varies
D2	9, 10, 11 & 14	3	22 (End 2)	Varies
D3	9 & 14	3	See Table	4'-3"
K	2, 9, 11 & 13	5	See Table	4'-2"
M1	9 & 10	4	9 (End 1)	Varies
M2	9 & 10	4	9 (End 2)	Varies
M3	9	4	See Table	3'-8"
N	3 & 4	3/8" Ø Strand	4	Dim. L
Y	9 & 11	5	12	2'-6"
Z	2, 9, 11 & 13	5	10	3'-8"

BENDING DIAGRAMS (See Note 1)

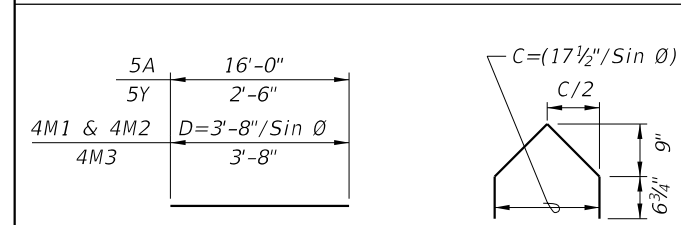

BARS 5A, 4M1, 4M2, BARS 3C1 & 3C2, 4M3 & 5Y

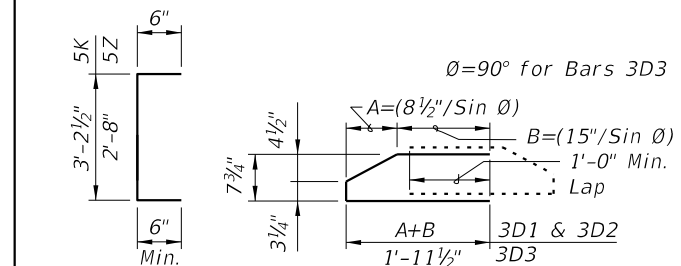

BARS 5K & 5Z BARS 3D1, 3D2 & 3D3

- NOTES:
- A. Work this Index with Index No. 20010 - Typical Florida-I Beam Details and Notes and the Florida-I Beam - Table of Beam Variables in Structures Plans.
  - B. For referenced notes, see Index No. 20010.
  - C. For Dimensions A, B, C, D, L, R & V1 and number of spaces S1 thru S4, see Florida-I Beam - Table of Beam Variables in Structures Plans.

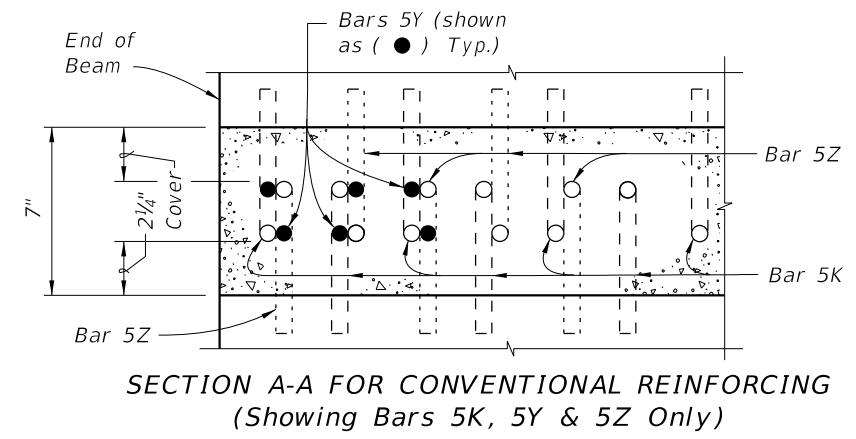

SECTION A-A FOR CONVENTIONAL REINFORCING (Showing Bars 5K, 5Y & 5Z Only)

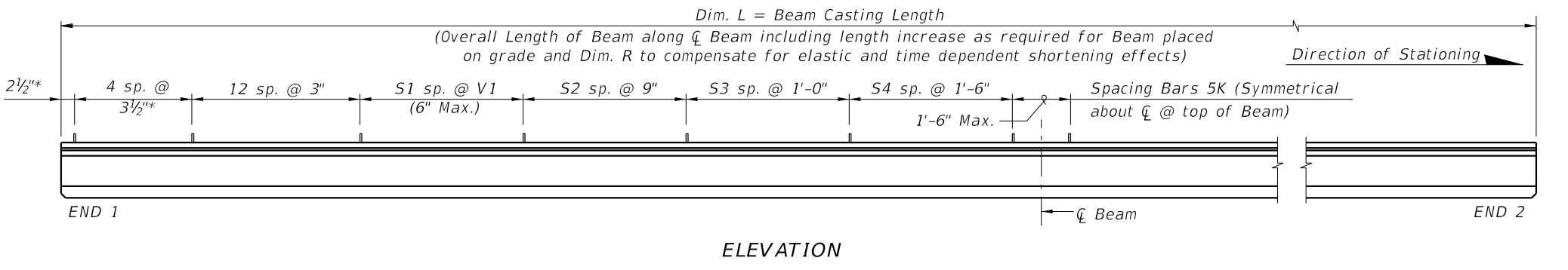

ELEVATION

12/17/2015 1:19:10 PM

LAST REVISION	DESCRIPTION:
07/01/12	

FY 2016-17 DESIGN STANDARDS

FLORIDA-I 36 BEAM - STANDARD DETAILS

INDEX NO.	SHEET NO.
20036	1 of 2

ALTERNATE REINFORCING STEEL (WELDED WIRE REINFORCEMENT) DETAILS

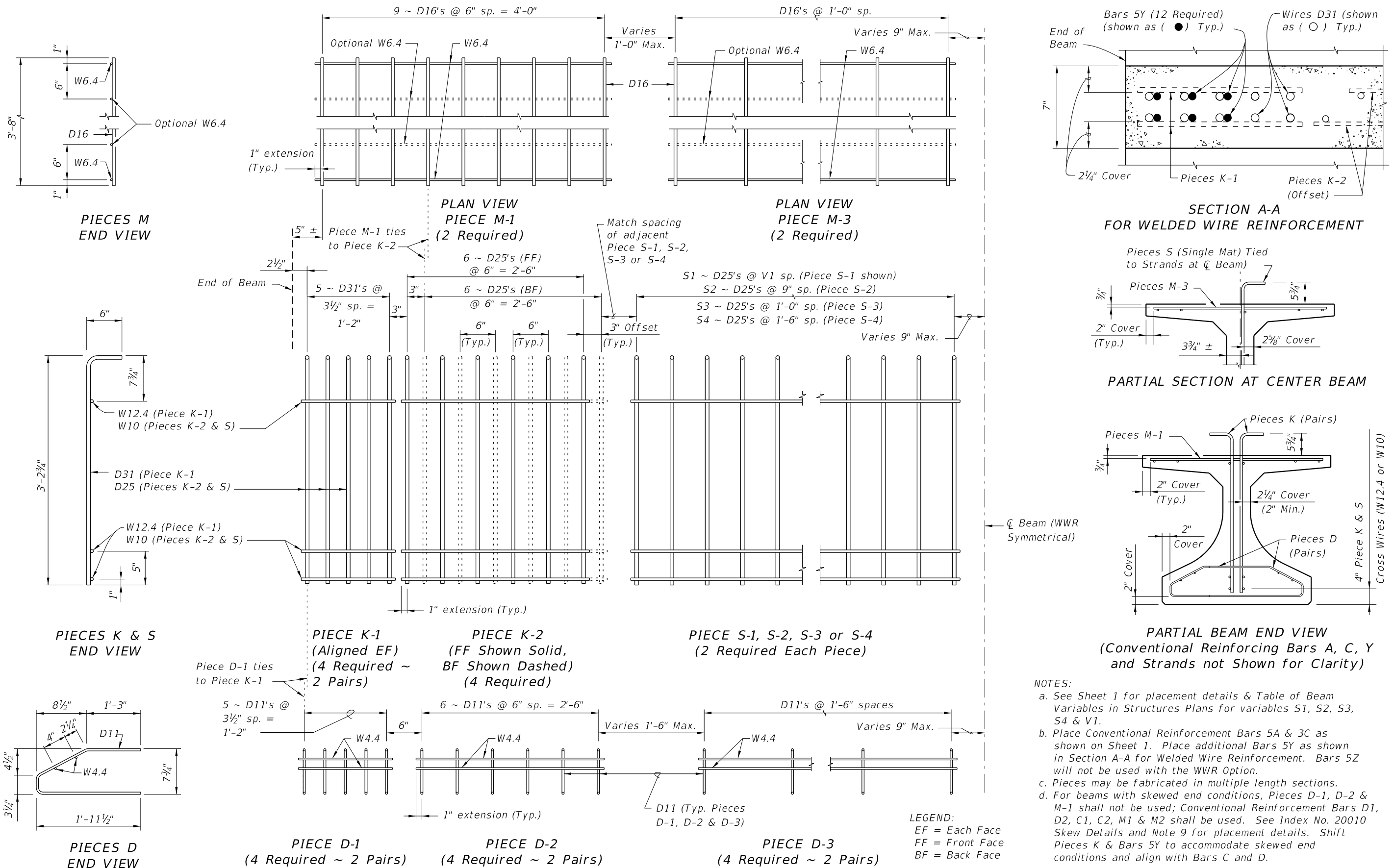

12/17/2015 1:19:11 PM

LAST REVISION	DESCRIPTION:
07/01/10	