

3D VIEW OF RAILING WITH TYPE 1 - PICKET INFILL PANEL  
(42" Height shown, 48" Height Similar)

TABLE 1 - RAILING MEMBERS

MEMBER	ALLOY <sup>(1)</sup>	DESIGNATION	OUTSIDE DIMENSION	WALL THICKNESS
Posts (Type "A" & "B")	6061-T6	RT 2x2x.250	2.00" x 2.00"	0.250"
Posts (Type "C")	6061-T6	Extrusion 1½x2½x.125	1.50" x 2.50"	0.125"
Top Plate (Type "C")	6061-T6	Extrusion (See Details)	2¾" x 7"	Varies
Top Rail	6061-T6	2½" NPS (Sch. 10)	2.875"	0.120"
		3" Round Top Cap Rail	3.000"	0.125"
End Hoops	6063-T5	2½" NPS (Sch. 10)	2.875"	0.120"
		3.00 OD x 0.125 Wall	3.000"	0.125"
Top Rail Joint/Splice Sleeves	6063-T5	2.50 OD x 0.125 Wall	2.500"	0.125"
		Top Cap Rail Inner Sleeve	2.800"	0.090"
Intermediate & Bottom Rail	6061-T6	RT 2x2x.250	2.00" x 2.00"	0.250" <sup>(2)</sup>
Int. & Bottom Rail Post Connection Sleeve	6063-T5	1.50 OD x 0.125 Wall <sup>(3)</sup>	1.500"	0.125"
Handrail Joint/Splice Sleeves	6063-T5	1" NPS (Sch. 40)	1.315"	0.133"
		1.50 OD x 0.125 Wall	1.500"	0.125"
Handrails	6061-T6	1½" NPS (Sch. 40)	1.900"	0.145"
Handrail Support Bar	6061-T6	¾" Ø Round Bar	0.750"	N/A
Pickets (Type 1 Infill Panel)	6061-T6	¾" Ø Round Bar	0.750"	N/A
Infill Panel Members (Types 2 - 5)	6063-T5	Varies (See Details)	Varies	Varies

TABLE 1 NOTES:

- (1) Alloy 6061-T6 or 6063-T52 & T6 may be substituted for Alloy 6063-T5.
- (2) 0.188" wall thickness permitted for rails with post spacings less than 5'-9".
- (3) 1" NPS (Sch. 40) non-slit rail sleeves may be substituted when welded connection Detail "K" is utilized.

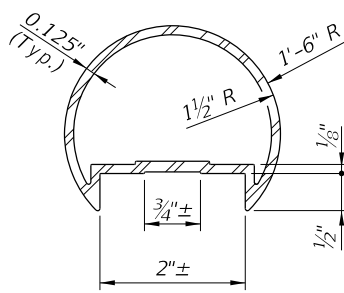

3" ROUND TOP CAP RAIL TOP CAP RAIL INNER SPLICE SLEEVE  
ALTERNATE TOP RAIL SECTION

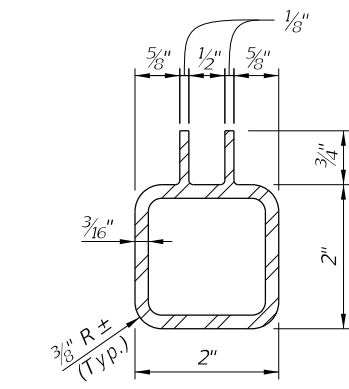
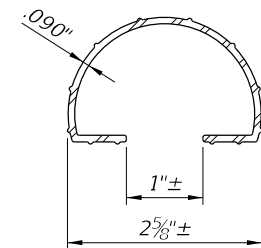

ALTERNATIVE BOTTOM & INTERMEDIATE RAIL SECTION FOR TYPE 3, 4 & 5 RAILINGS

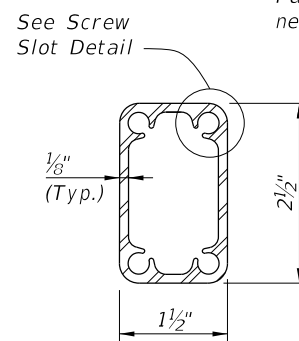

POST TYPE "C" SCREW SLOT SECTION

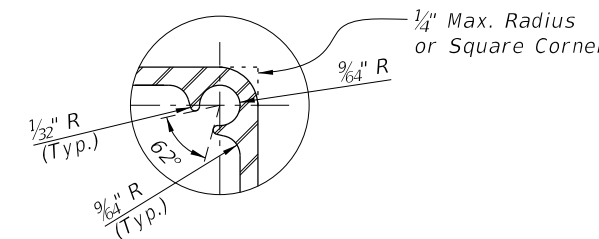

SCREW SLOT DETAIL

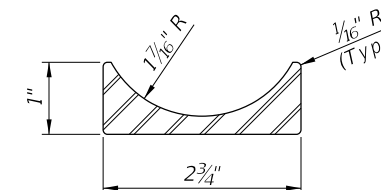

OPTIONAL TOP PLATE EXTRUSION SECTION (POST TYPE "C")

DESIGN LOADS, GEOMETRY AND APPLICABILITY:

See the Instructions for Design Standards for the design loads, geometry and applicability requirements.

GENERAL:

Adequate foundation support shall be provided for anchorage and stability against overturning (See Sheet 8). See Index No. 861 for special requirements and modifications for use on bridges. The railing shown on these drawings requires a handrail for ramps steeper than a 5% grade to conform with the requirements of the Americans with Disabilities Act (ADA).

RAILS, PANELS AND POSTS:

Structural Extrusions, Tube, Pipe and Bar shall be in accordance with Table 1 and ASTM B221 or ASTM B429. Top, bottom and intermediate rail corner bends with maximum 4'-0" post spacing, may be Alloy 6063-T6. Perforated panels (Type 5) shall be Alloy 3003-H14. Posts shall be fabricated and installed plumb, ± 1" tolerance when measured at 3'-6" above the foundation. Pickets and vertical panel elements shall be fabricated parallel to the posts, except that Type 2, 3 & 5 panel infills may be fabricated parallel to the longitudinal grade. Corners and changes in tangential longitudinal alignment shall be made continuous with a 9" bend radius or terminate at adjoining sections with mitered end sections when handrails are not required. For changes in tangential longitudinal alignment greater than 45°, posts shall be positioned at a maximum distance of 2'-0" each side of the corner and shall not be located at the corner apex. For curved longitudinal alignments the top and bottom rails and handrails shall be shop bent to match the alignment radius.

BASE PLATES AND RAIL CAPS:

Base Plates and Post Cap plates shall be in accordance with ASTM B209, Alloy 6061-T6.

SHIM PLATES:

Shim Plates shall be aluminum in accordance with ASTM B209, Alloy 6061 or 6063. Shim plates shall be used for foundation height adjustments greater than ¼" between 3 posts and localized irregularities greater than ½" beneath base plates. Field trim shim plates when necessary to match the contours of the foundation. Beveled shim plates may be used in lieu of trimmed flat shim plates shown. Stacked shim plates must be bonded together with adhesive bonding material and limited to a maximum total thickness of ½", unless longer anchor bolts are provided for the exposed thread length.

ANCHOR BOLTS:

Anchor bolts shall be in accordance with ASTM F1554 (Grade 36 for 7/8" Ø and Grade 55 for 7/16" Ø 4-Bolt Anchorage). Headless anchor bolts for Adhesive Anchors shall be threaded full length. Cutting of reinforcing steel is permitted for drilled hole installation. Expansion Anchors are not permitted. All anchor bolts shall have single self-locking hex nuts. Tack welding of the nut to the anchor bolt may be used in lieu of self-locking nuts. All nuts shall be in accordance with ASTM A563 or ASTM A194. Flat Washers shall be in accordance with ASTM F436 and Plate Washers (for long slotted holes only), shall be in accordance with ASTM A36 or ASTM A709 Grade 36. After the nuts have been snug tightened, distort the anchor bolt threads to prevent removal of the nuts. Distorted threads and tack welds shall be coated with a galvanizing compound in accordance with the Specifications.

RESILIENT AND NEOPRENE PADS:

Resilient and Neoprene pads shall be in accordance with Specification Section 932 except that testing of the finished pads shall not be required. Neoprene pads shall be durometer hardness 60 to 80.

JOINTS:

Grind welded joints as necessary to remove burrs and weld splatter, additionally remove any sharp edges on rails to prevent injury. Grind all plug welds smooth. Expansion joints shall be spaced at a maximum 40'-0". Field splices similar to the expansion joint detail may be approved by the Engineer to facilitate handling, but top rail must be continuous across a minimum of two posts. For intermediate and bottom horizontal rails the screwed joints shown on Sheet 4 may be substituted with alternate joints shown on Sheet 3 Detail "K" for Post Type "A" & "B".

WELDING:

All welding shall be in accordance with the American Welding Society Structural Welding Code (Aluminum) ANSI/AWS D1.2 (current edition). Filler metal shall be either ER5183, ER5356 or ER5556. Nondestructive testing of welds is not required. Filler metal for plug welds and bend splices may be ER4043.

COATINGS:

The aluminum railing shall be mill finish unless otherwise noted in the Contract Documents. All nuts, bolts and washers shall be galvanized in accordance with Specification Section 962.

SHOP DRAWINGS:

Details addressing project specific geometry (line & grade) showing post and expansion joint locations, post and panel type, anchor bolt installation "Case" or lengths, must be submitted by the Contractor for the Engineer's approval prior to fabrication of the railing. Shop drawings shall be in accordance with the Specifications.

PAYMENT:

Payment includes rails, posts, pickets, panels, rail splice assembly, base plates, anchor bolts, nuts, washers, resilient or neoprene pads and all incidental materials and labor required to complete installation of the railing.

11:42:59 AM  
12/17/2015

LAST REVISION 01/01/16	REVISION	DESCRIPTION:	FY 2016-17 DESIGN STANDARDS	ALUMINUM PEDESTRIAN/BICYCLE RAILING	INDEX NO. 862	SHEET NO. 1 of 9
---------------------------	----------	--------------	--------------------------------	-------------------------------------	------------------	---------------------

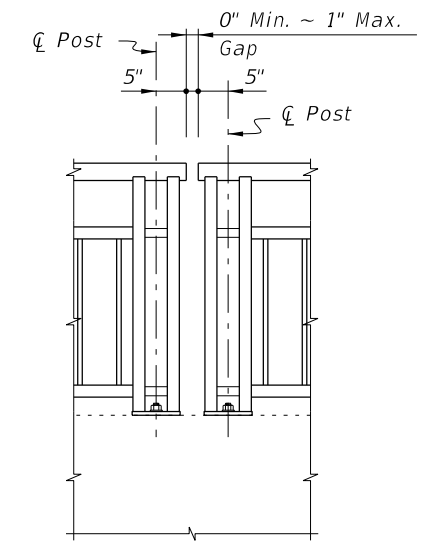
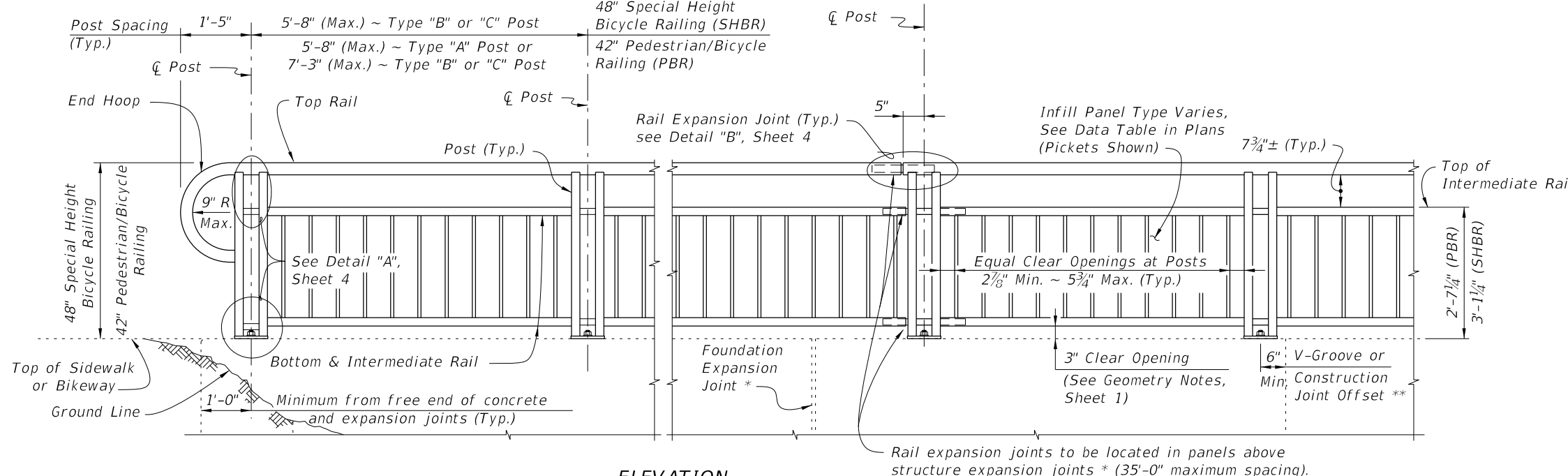

Note: Non-continuous corners are permitted when handrails are not required.

**ELEVATION**  
(Showing Outside Face of Railing with Type "A" Posts)

**EXPANDED ELEVATION AT CORNERS**  
**DETAIL FOR NON-CONTINUOUS RAILING AT CORNERS**

**TYPICAL RAILING DETAILS & RAILINGS ON GRADES 0% TO 5%**  
(Type 1 - Picket Railing Shown, Other Types Similar)

**NOTES:**  
\* Keyed construction joints in Index No. 6011 Gravity Wall are not considered to be expansion joints.  
\*\* Contraction joints (Tooled or Saw Cut) in sidewalks do not require a 6" minimum offset.

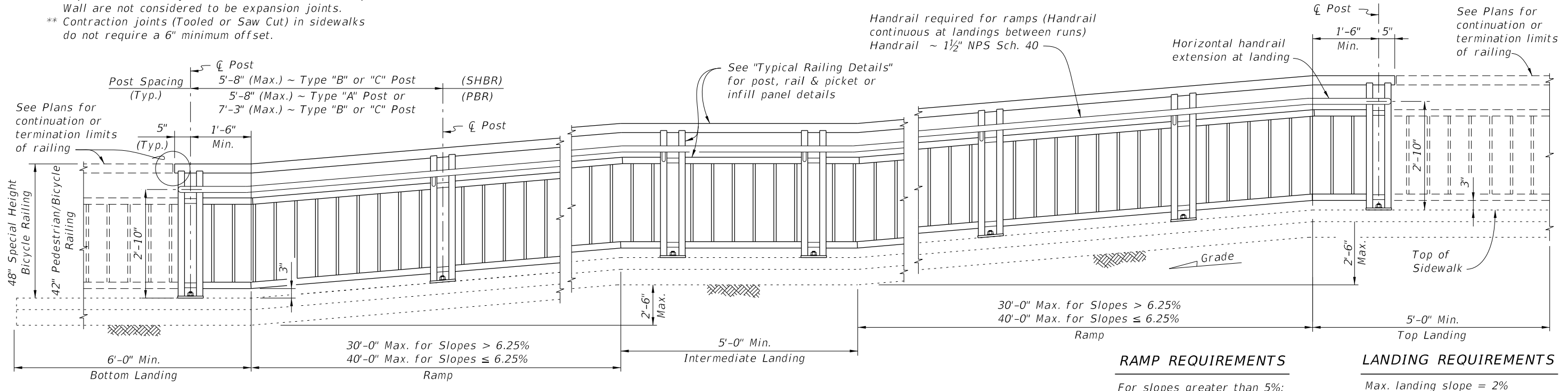

**ELEVATION**  
(Showing Inside Face of Railing with Type "A" Posts)

**RAILINGS ON GRADES STEEPER THAN 5%**  
(Type 1 - Picket Railing Shown, Other Types Similar)

12/17/2015 11:43:02 AM

LAST REVISION 07/01/15	REVISION	DESCRIPTION:	 FY 2016-17 DESIGN STANDARDS	ALUMINUM PEDESTRIAN/BICYCLE RAILING	INDEX NO. 862	SHEET NO. 2 of 9
---------------------------	----------	--------------	------------------------------------	-------------------------------------	------------------	---------------------

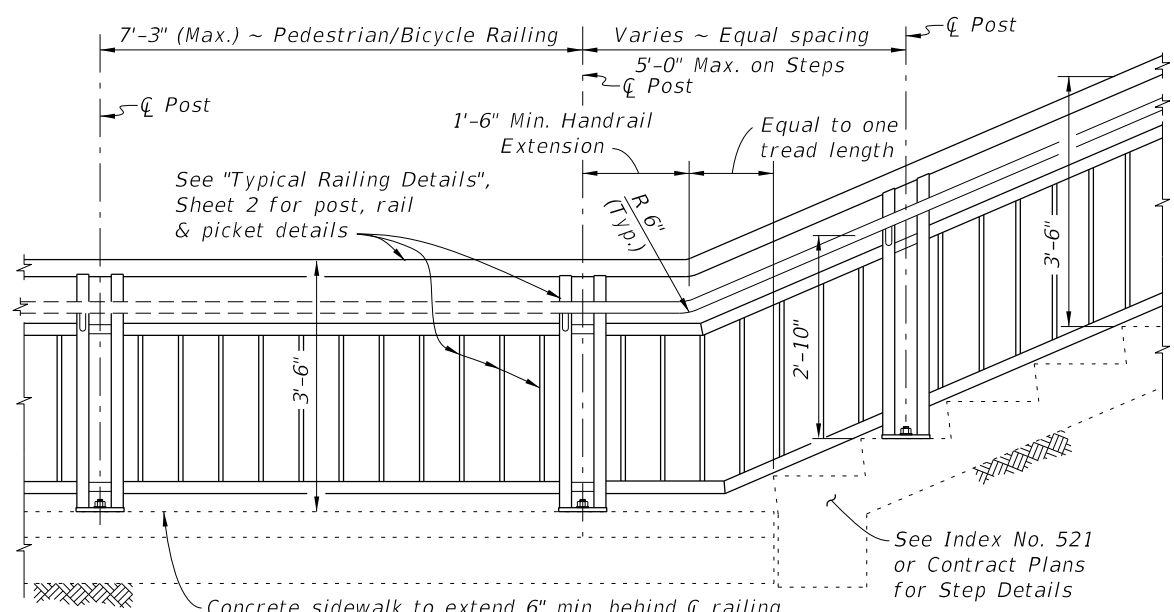

**RAILING CONTINUATION BEYOND STEPS OR STAIRS**  
(Bottom shown, Top similar)

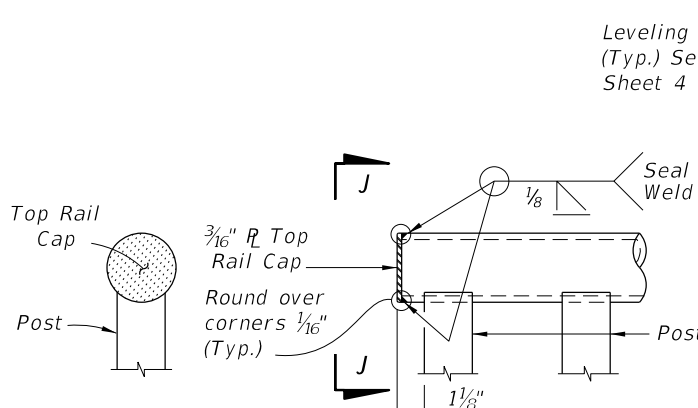

**VIEW J-J DETAIL "J" - ELEVATION VIEW TOP RAIL TERMINATION**

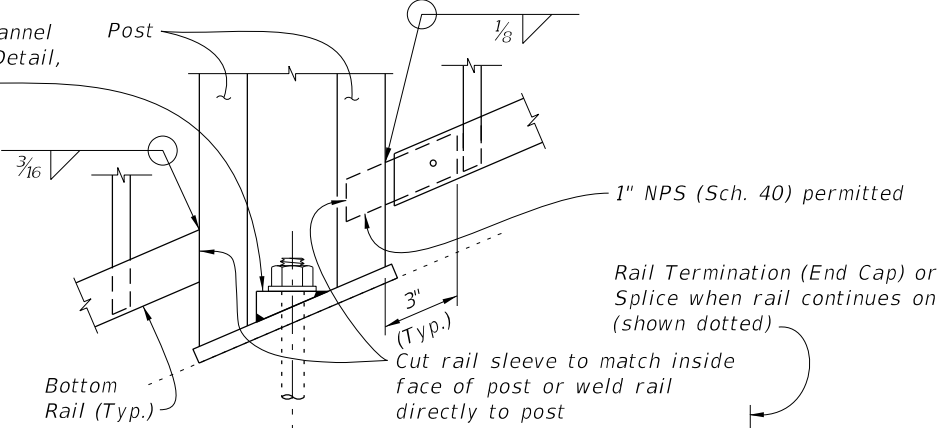

**DETAIL "K" - ELEVATION VIEW BOTTOM RAIL CONNECTION (Intermediate Rail Similar)**

**RAIL TERMINATION DETAILS**

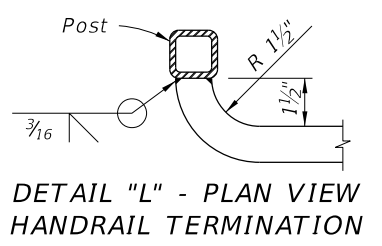

**DETAIL "L" - PLAN VIEW HANDRAIL TERMINATION**

Aluminum Handrail required for three or more steps (Handrail and cheekwalls continuous at landings)  
Handrails ~ 1 1/2" NPS (Sch. 40) pipe

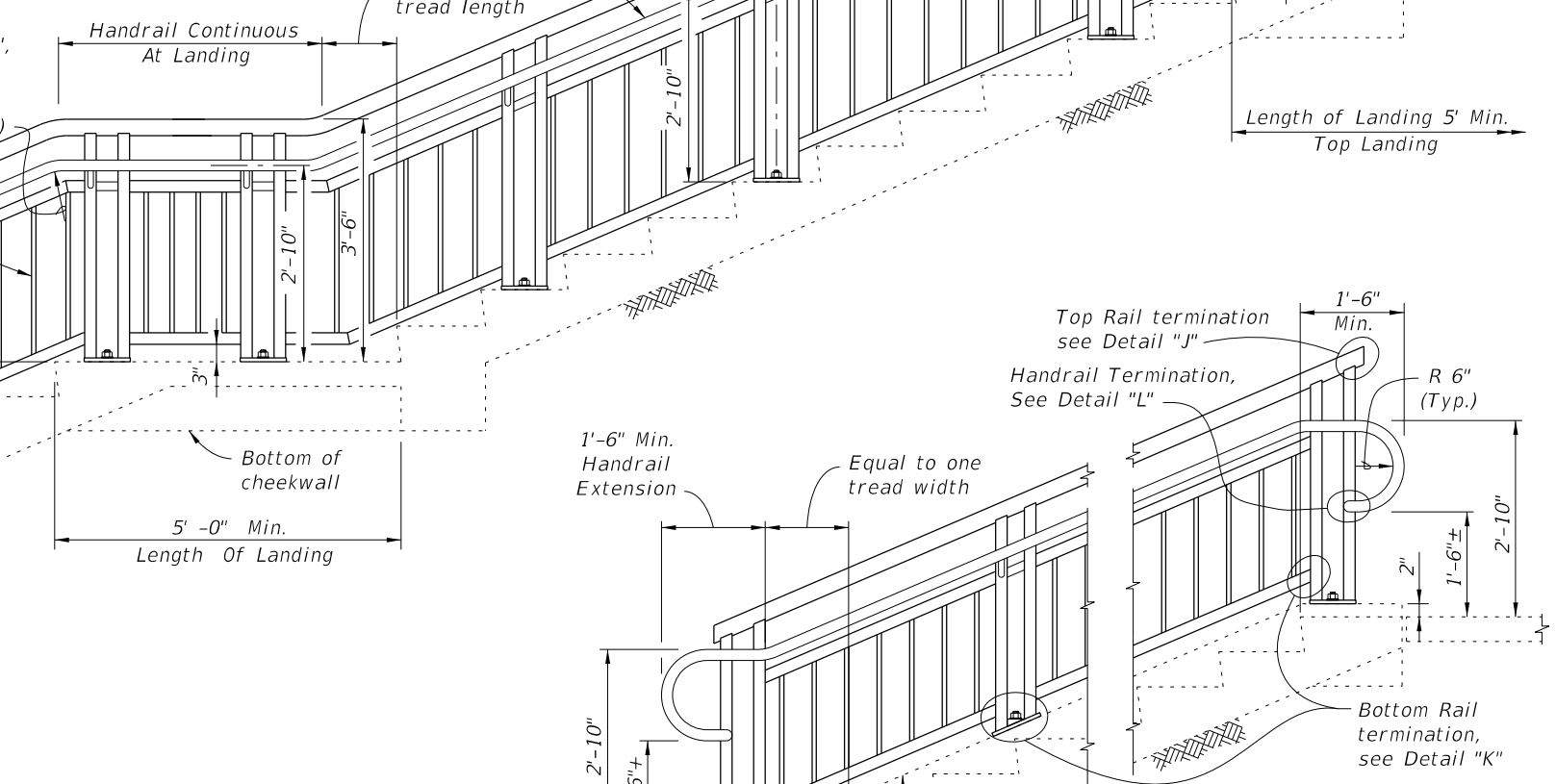

**ELEVATION (At-Grade Steps shown, Elevated Stairs similar)**

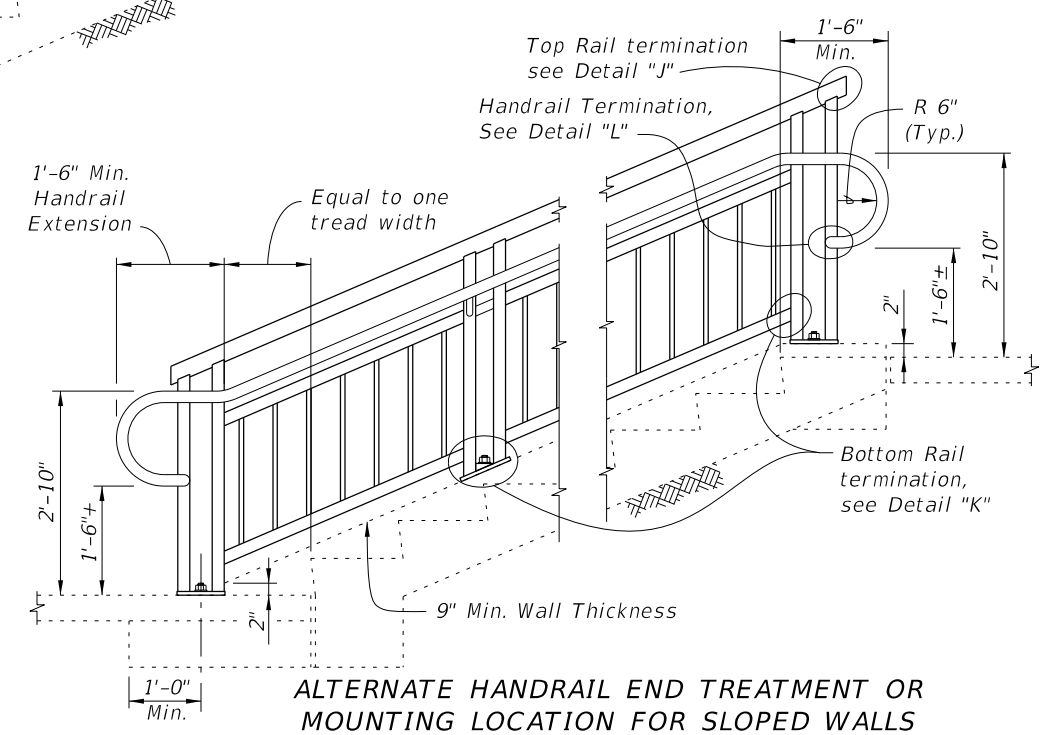

**ALTERNATE HANDRAIL END TREATMENT OR MOUNTING LOCATION FOR SLOPED WALLS**

**RAILINGS ON STEPS & STAIRS**

12/17/2015 11:43:03 AM

LAST REVISION 07/01/15	DESCRIPTION:	FY 2016-17 DESIGN STANDARDS	INDEX NO. 862	SHEET NO. 3 of 9
REVISION		FDOT		
		ALUMINUM PEDESTRIAN/BICYCLE RAILING		

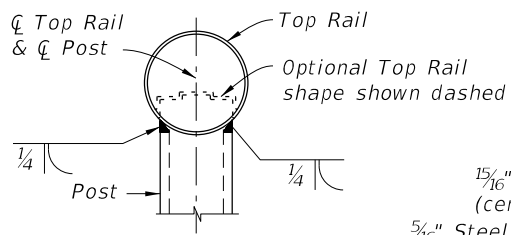

SECTION A-A  
(Top Rail Connection)

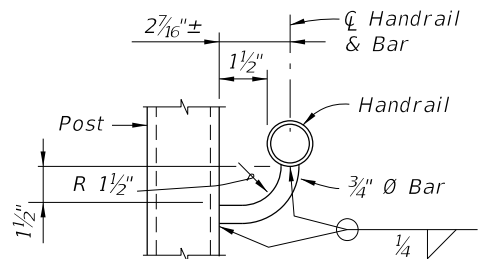

SECTION B-B  
(Handrail Connection)

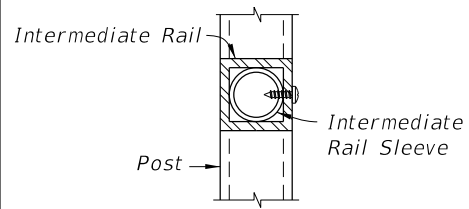

SECTION C-C  
(Intermediate Rail Connection)

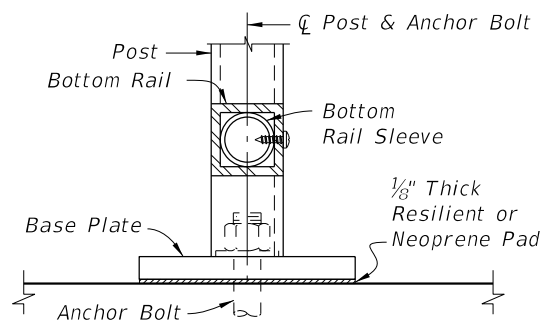

SECTION D-D  
(Bottom Rail Connection -  
Single Anchor Bolt Shown)

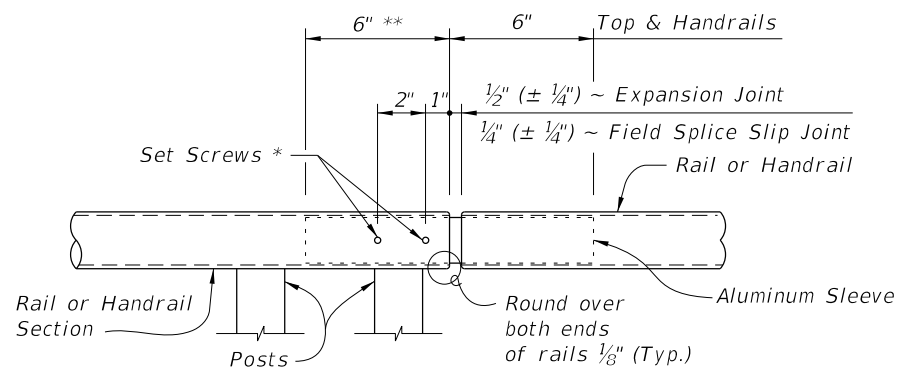

ROUND RAILS - TOP RAIL OR HANDRAIL  
(Top Rail at Expansion Joint Shown)

DETAIL "B" - EXPANSION JOINT (FIELD SPICE SLIP JOINT SIMILAR)

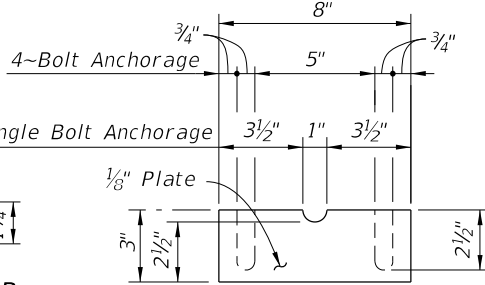

SHIM PLATE DETAIL



PLATE WASHER  
DETAIL

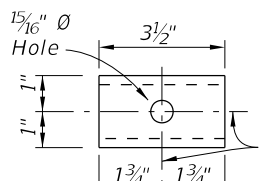

TOP VIEW

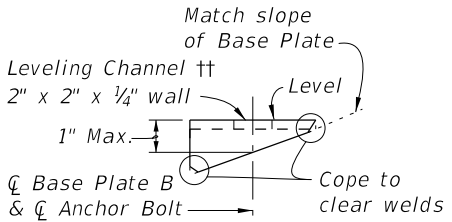

SIDE VIEW

LEVELING CHANNEL DETAIL

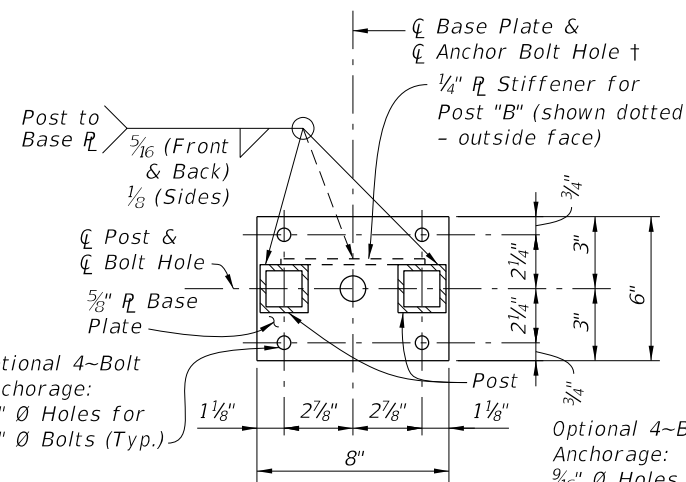

BASE PLATE A

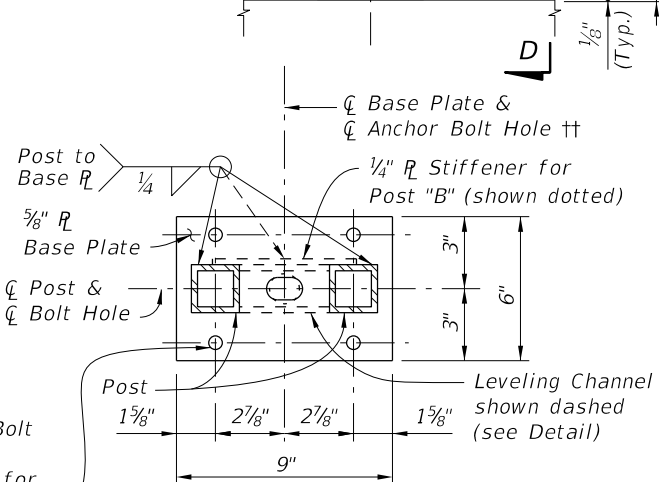

BASE PLATE B

SECTION G-G - BASE PLATE DETAILS

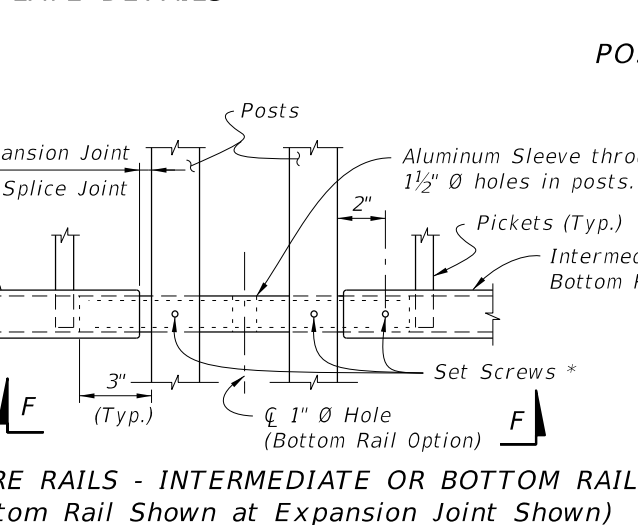
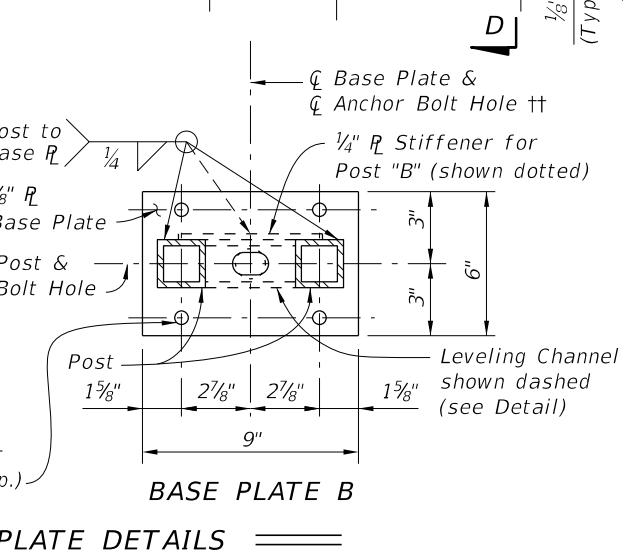
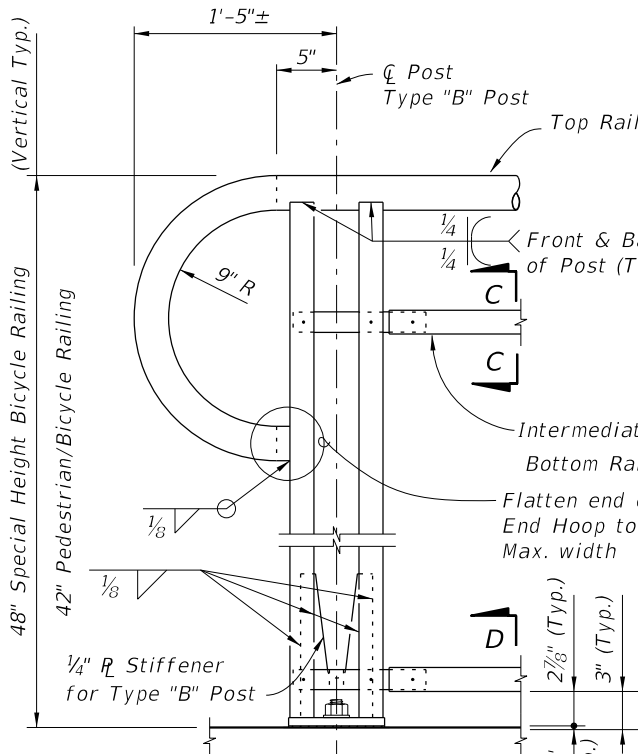

SQUARE RAILS - INTERMEDIATE OR BOTTOM RAIL  
(Bottom Rail Shown at Expansion Joint Shown)

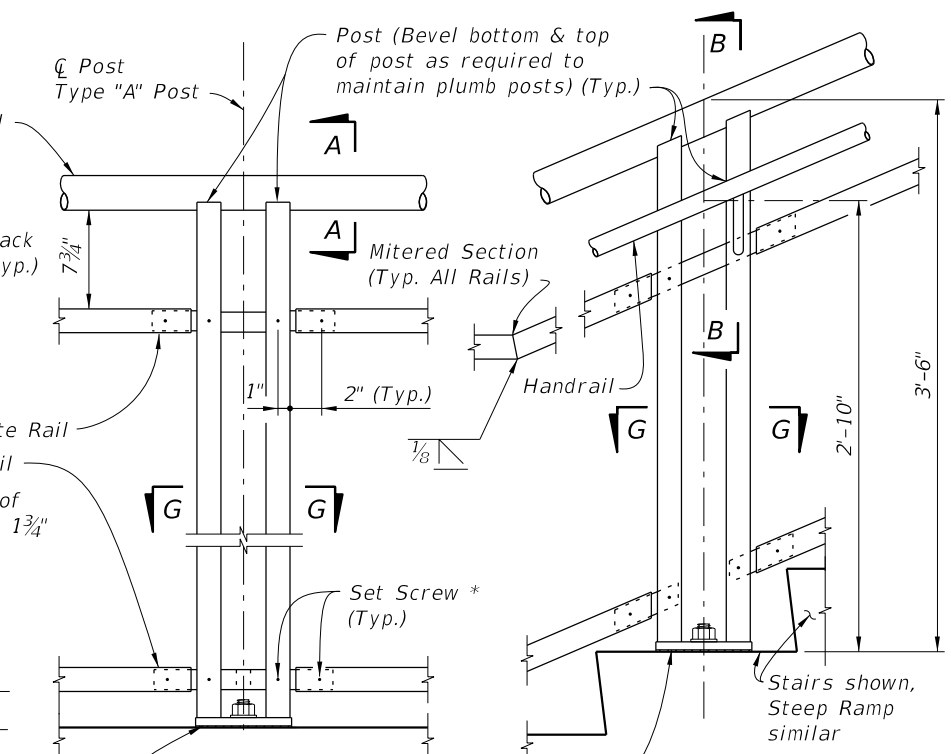

DETAIL "A" - RAIL CONNECTIONS  
(Showing Inside Face of Railing)  
(Pickets/Panels and 4-Bolt Anchorage Not Shown for Clarity)

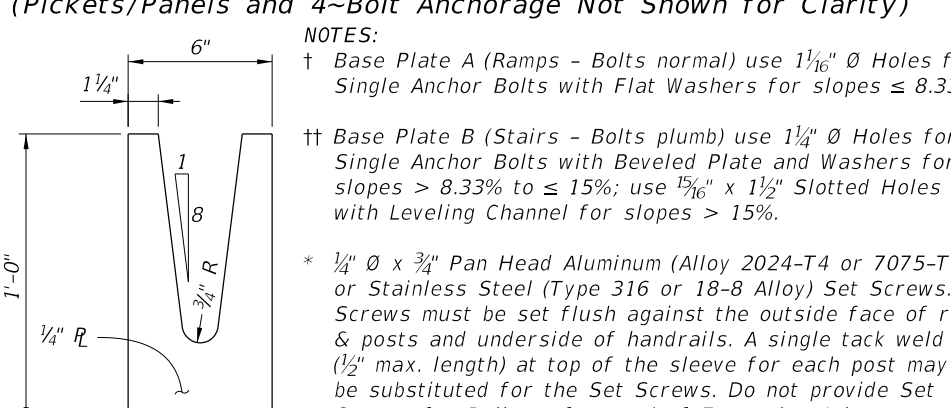

POST "B" STIFFENER  
DETAIL

NOTES:  
 † Base Plate A (Ramps - Bolts normal) use 1 1/16 inch diameter holes for single anchor bolts with flat washers for slopes <= 8.33%.  
 †† Base Plate B (Stairs - Bolts plumb) use 1/4 inch diameter holes for single anchor bolts with beveled plate and washers for slopes > 8.33% to <= 15%; use 15/16 inch x 1 1/2 inch slotted holes with leveling channel for slopes > 15%.  
 \* 1/4 inch diameter x 3/4 inch pan head aluminum (Alloy 2024-T4 or 7075-T73) or stainless steel (Type 316 or 18-8 Alloy) set screws. Screws must be set flush against the outside face of rails & posts and underside of handrails. A single tack weld (1/2 inch max. length) at top of the sleeve for each post may be substituted for the set screws. Do not provide set screws for rails at free end of expansion joints.  
 \*\* Embedded length may be 4 inches for plug welded connection.

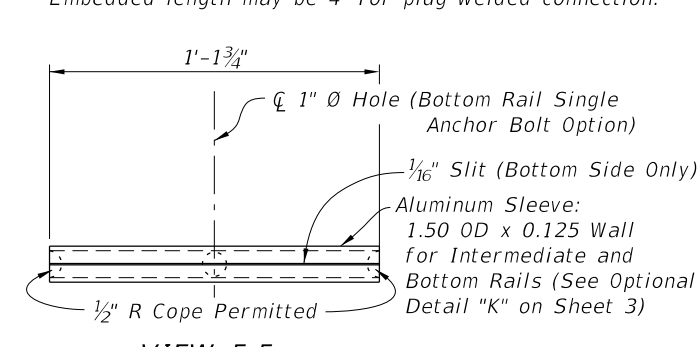

VIEW F-F  
INTERMEDIATE OR BOTTOM RAIL -  
ALUMINUM SLEEVE DETAIL (Bottom Side Shown)

CROSS REFERENCE:  
 For location of details "B", see sheet 2.

12/17/2015 11:43:04 AM

LAST REVISION 07/01/15	DESCRIPTION:	FY 2016-17 DESIGN STANDARDS	INDEX NO. 862	SHEET NO. 4 of 9
---------------------------	--------------	--------------------------------	------------------	---------------------

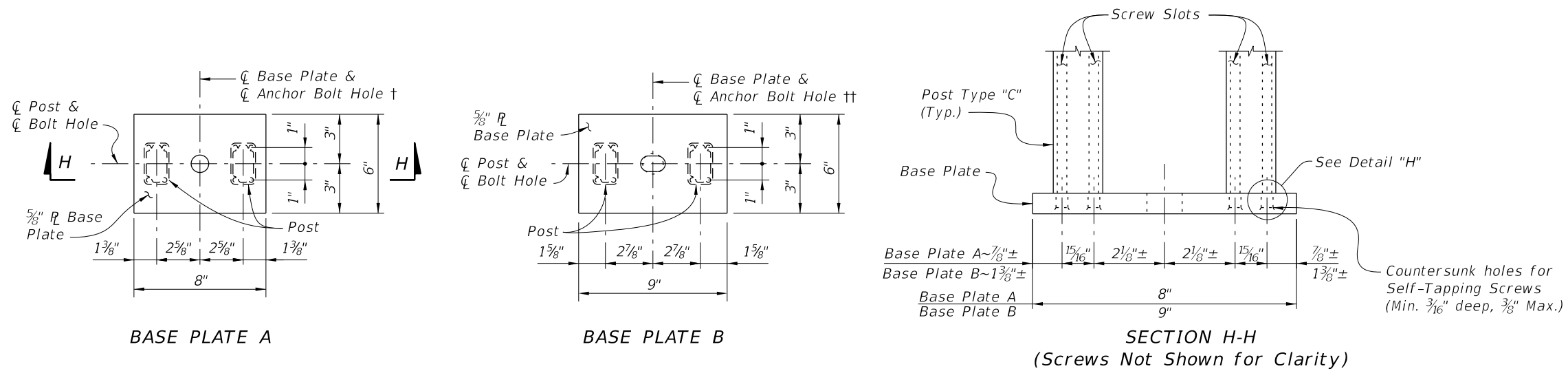

BASE PLATE DETAILS FOR TYPE "C" POST

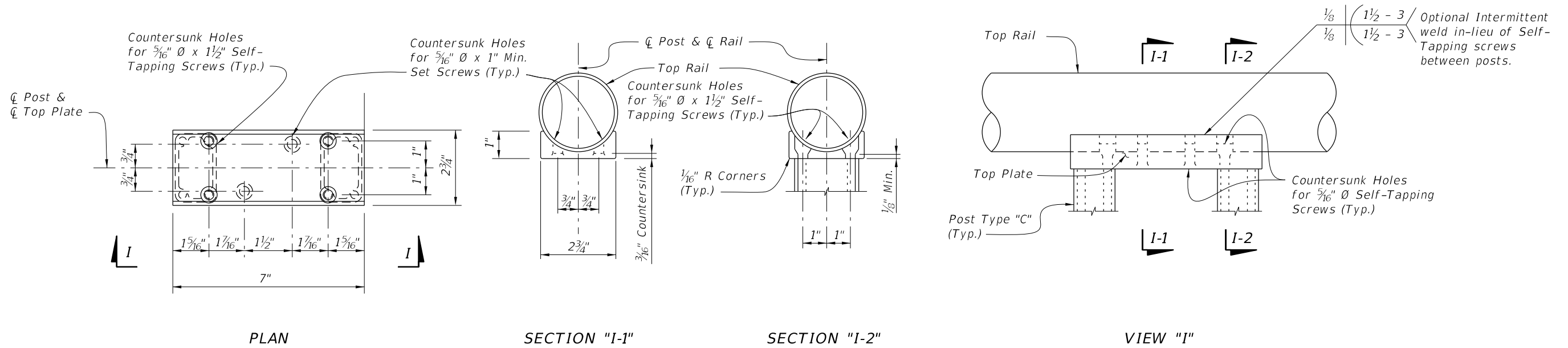

TOP PLATE DETAILS FOR TYPE "C" POST  
 (Screws Not Shown For Clarity)

† See Sheet 4 for Notes.  
 †† See Sheet 4 for Notes.  
 ††† Length varies for beveled posts on grades. Holes must be drilled plumb to align with screw slot.

12/17/2015 11:43:05 AM

LAST REVISION 07/01/15	DESCRIPTION:	FDOT FY 2016-17 DESIGN STANDARDS	ALUMINUM PEDESTRIAN/BICYCLE RAILING	INDEX NO. 862	SHEET NO. 5 of 9
---------------------------	--------------	--	-------------------------------------	------------------	---------------------

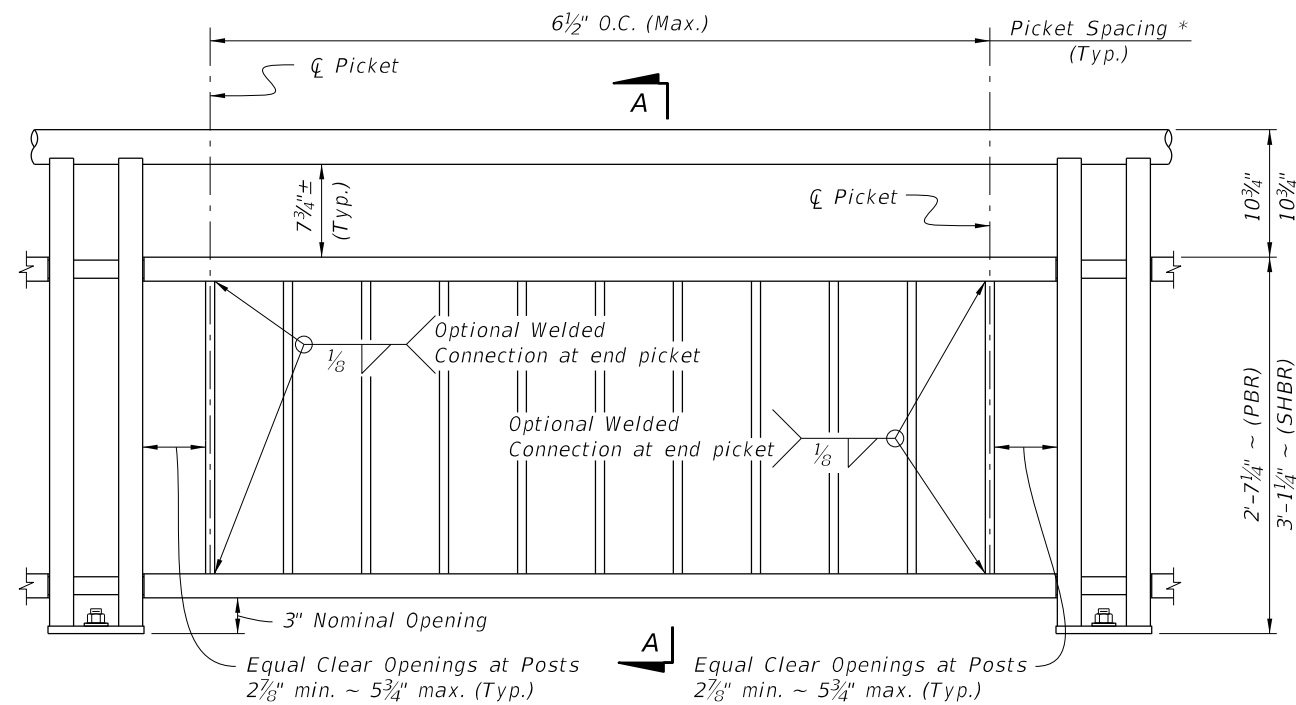

**TYPE 1 - PICKET INFILL PANEL**

**PICKET NOTES:**

\* Picket Spacing of 6 1/2" centers is based on a 3/4" Ø Bar for standard applications. When shown in the Contract Plans a 4 1/2" picket spacing may be required. If an alternate design is used, maintain a maximum clear opening of 5 7/8" for standard installations and 3 7/8" for special conditions.

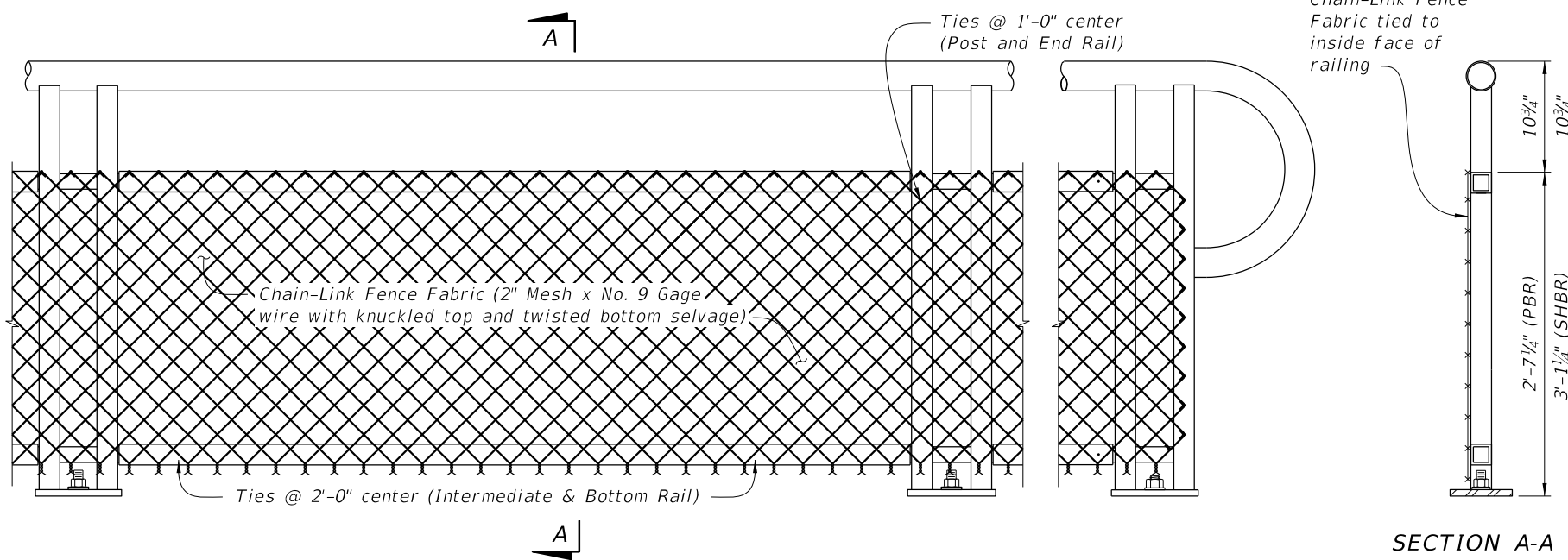

**TYPE 2 - CHAIN-LINK (Continuous Infill Panel)**

**NOTES:**

1. See Plans for Infill Panel option required.

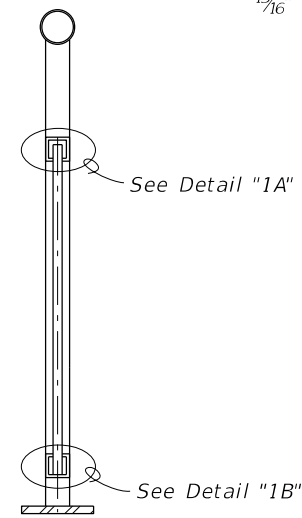

**SECTION A-A**

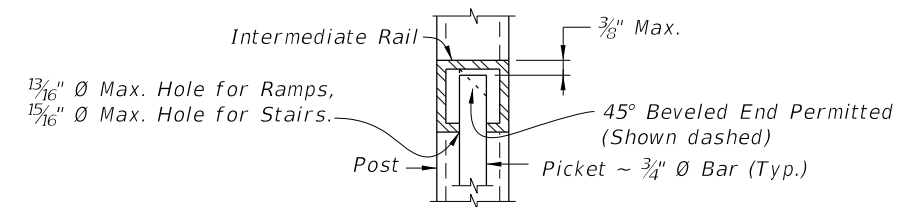

**DETAIL "1A"  
(Top of Picket Connection)**

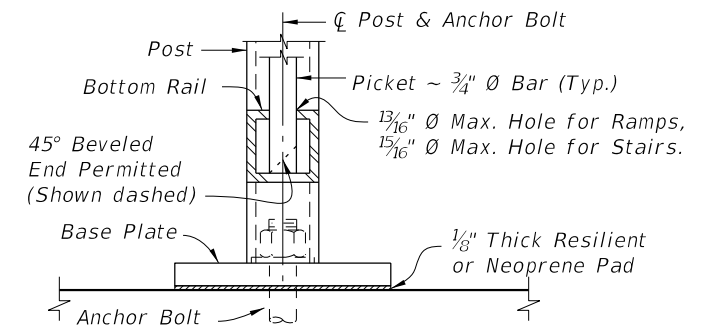

**DETAIL "1B"  
(Bottom of Picket Connection)**

TABLE 2 - CHAIN-LINK PANEL COMPONENT MATERIALS		
COMPONENT	ASTM	COMPONENT INFORMATION
Chain-Link Fence Fabric (2" mesh with twisted bottom and knuckled top selvage)	A 392	Zinc-Coated Steel - No. 9 gage (coated wire diameter), Class 2 Coating
	A 491	Aluminum-Coated Steel - No. 9 gage (coated wire diameter)
	F 668	Polyvinyl Chloride (PVC) Coated Steel - No. 9 gage Zinc-Coated Wire (metallic-coated core wire diameter) ~ See Plans for specified color of PVC.
Tie Wires	F 626	Zinc-Coated Steel Wire - No. 9 gage with coating to match Chain-Link Fence Fabric.
Tension Bars	F 626	3/16" (min. thickness) x 3/4" (min. width) x 2'-3' (min. height) Steel Bars
Miscellaneous Fence Components	F 626	Zinc-Coated Steel

**CHAIN-LINK PANEL NOTE:**

Chain-Link Fence Fabric shall be continuous along limits of railing. Splicing of Chain-Link panels using Tension Bars at 20'-0" minimum increments is permitted.

12/17/2015 11:43:05 AM

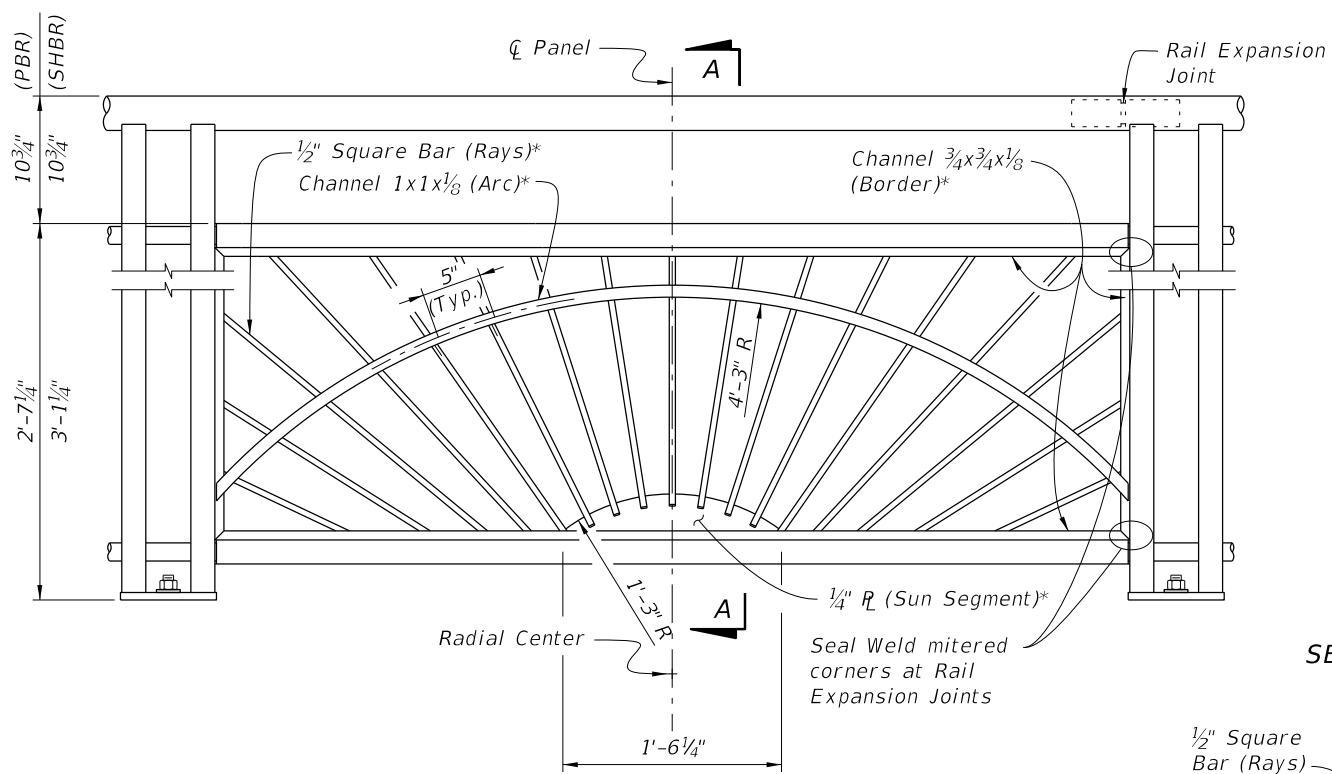

**TYPE 3 - SUNSHINE INFILL PANEL**

\* Arc, Rays and Sun Segment may be formed in a single panel from 1/2" plate (ASTM B209 Alloy 6061-T6 or T651) pattern cut with laser or plasma CNC, welded to a 1x1 1/8 Angle Border or the 3/4x3/4x1/8 Channel Border shown.

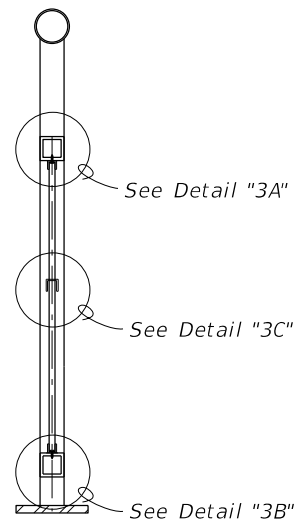

**SECTION A-A**

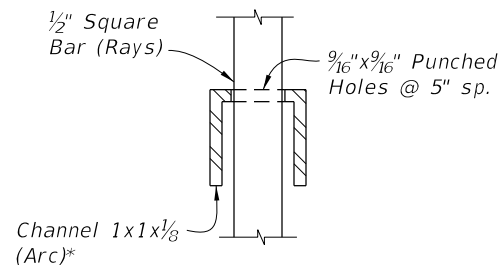

**DETAIL "3C"  
RAY/ARC CONNECTION**

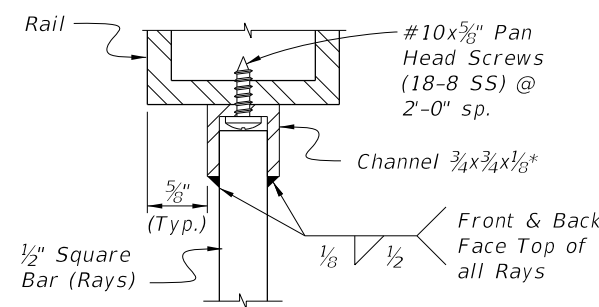

**DETAIL "3A"  
INTERMEDIATE RAIL/RAY CONNECTION**

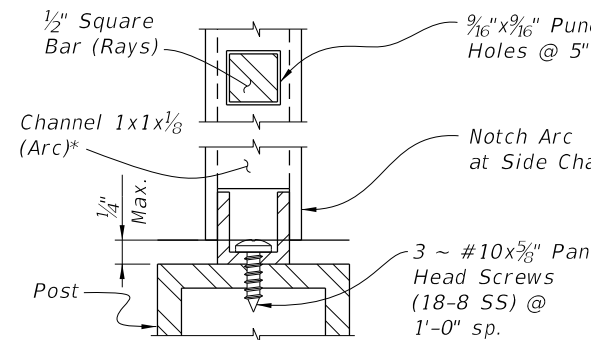

**DETAIL "3D"  
ARC/POST CONNECTION  
(Continuous Top Rail)**

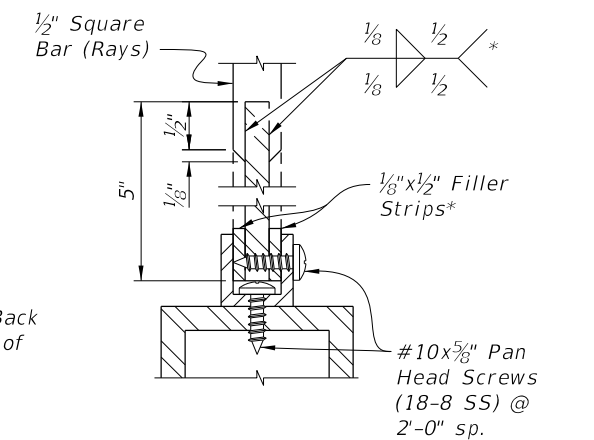

**DETAIL "3B"  
BOTTOM RAIL/RAY CONNECTION**

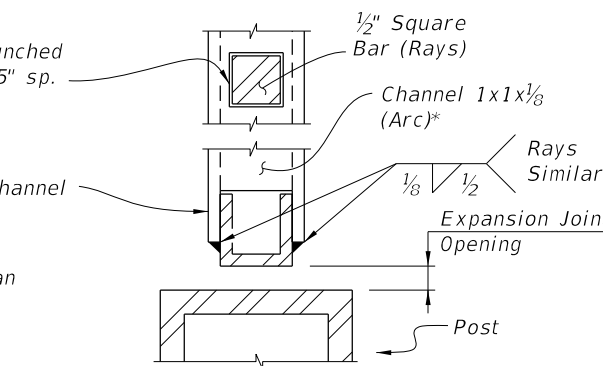

**DETAIL "3E"  
PANEL END CONNECTION  
AT POST WITH EXPANSION JOINT**

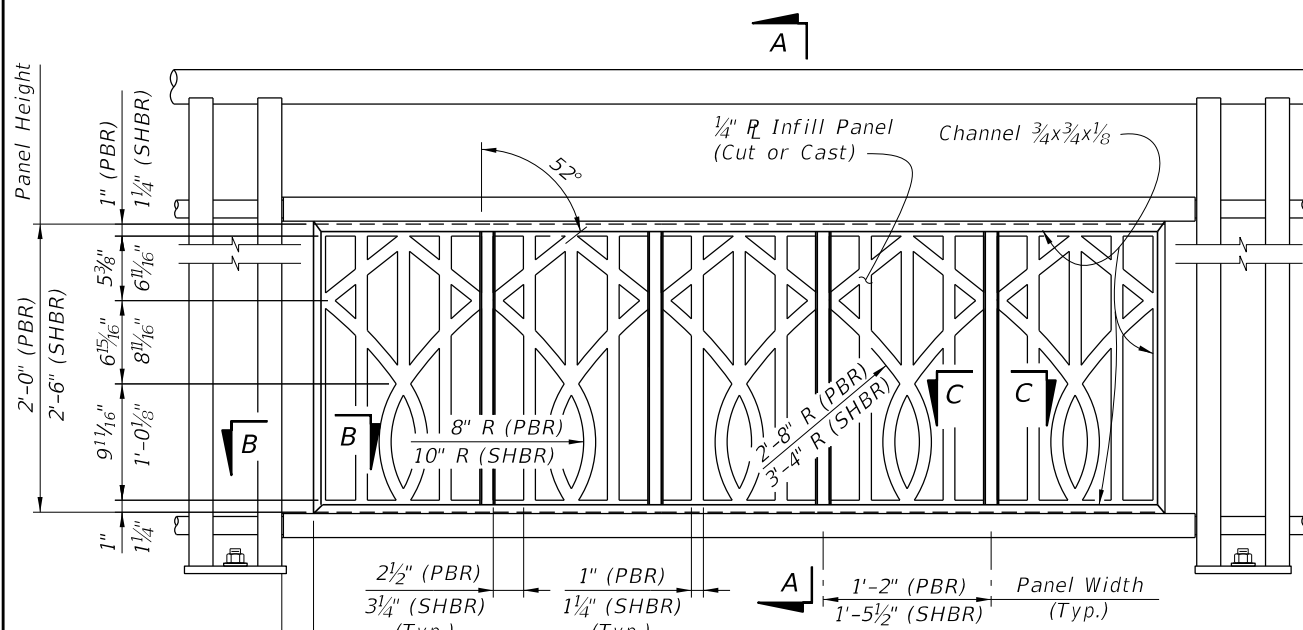

**TYPE 4 - BROADWAY INFILL PANEL**

NOTES:

1. See Plans for Infill Panel Option required.

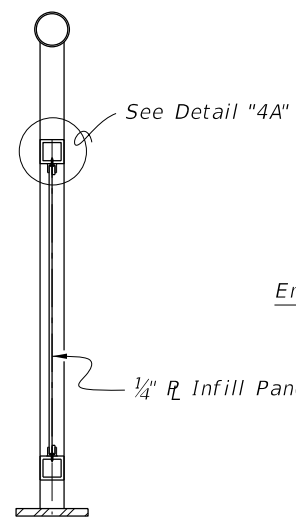

**SECTION A-A**

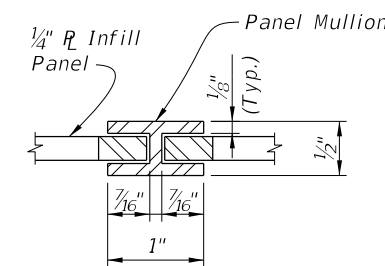

**SECTION C-C  
PANEL/SPLICE CONNECTION**

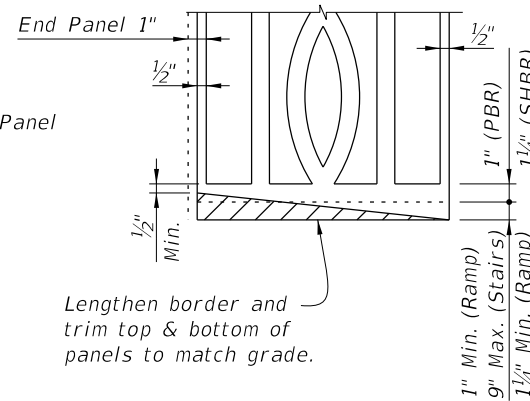

**PANEL ADJUSTMENT FOR RAILINGS  
ON GRADES**

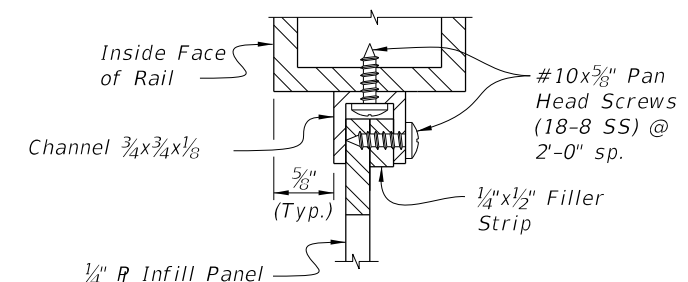

**DETAIL "4A"  
PANEL/RAIL CONNECTION  
(Top Shown, Bottom Similar)**

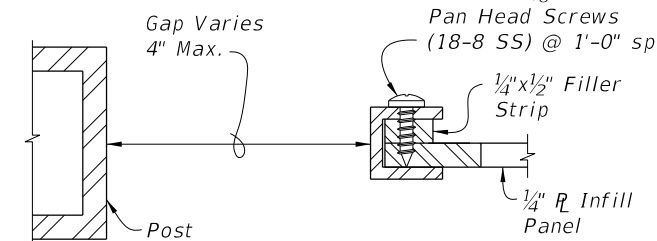

**SECTION B-B  
PANEL END CAP**

12/17/2015 11:43:06 AM

LAST REVISION 07/01/15	REVISION	DESCRIPTION:	<b>FY 2016-17 DESIGN STANDARDS</b>	<b>ALUMINUM PEDESTRIAN/BICYCLE RAILING</b>	INDEX NO. 862	SHEET NO. 7 of 9
---------------------------	----------	--------------	--	--	------------------	---------------------

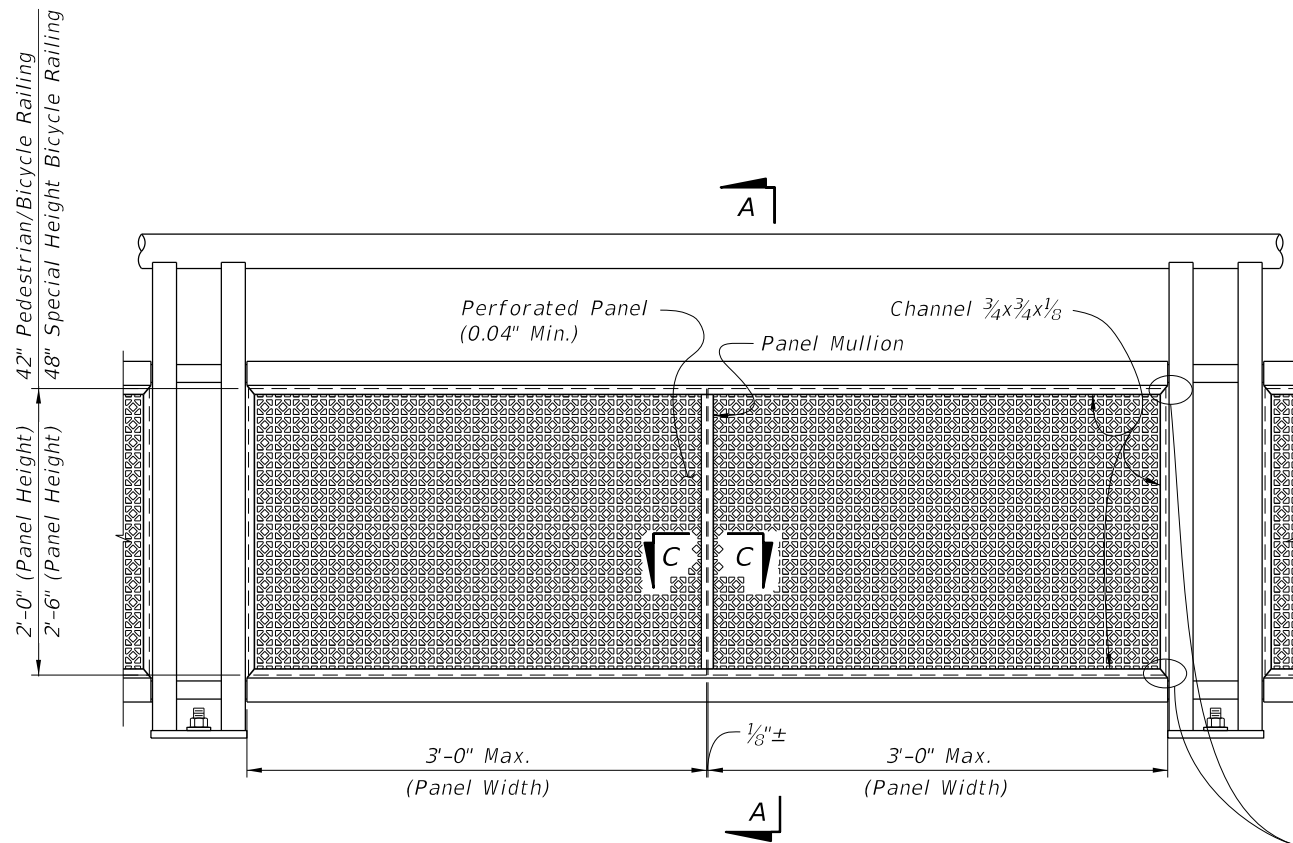

**TYPE 5 - PERFORATED INFILL PANEL**

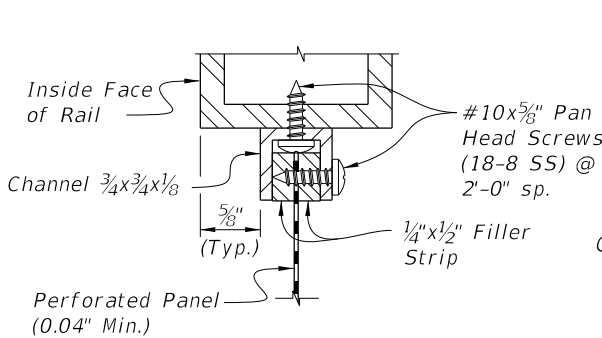
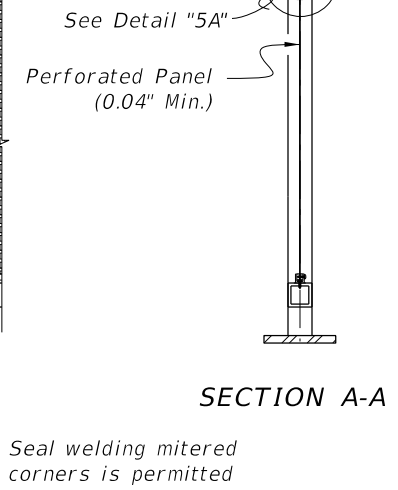

**DETAIL \"5A\"  
PANEL/RAIL CONNECTION  
(Top Shown, Bottom Similar)**

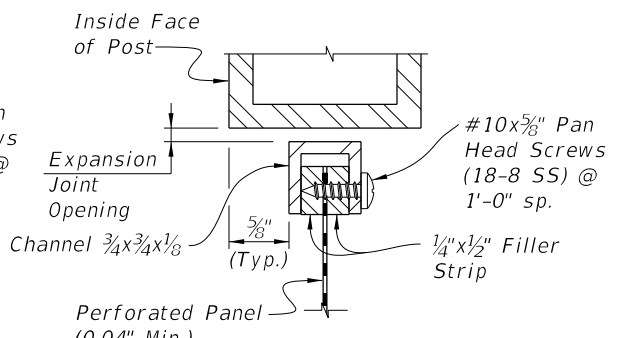

**DETAIL \"5B\"  
PANEL END CONNECTION  
(Expansion Joint Shown, Sides Similar)**

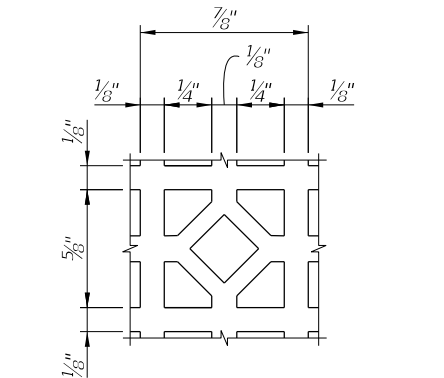

**REPEATING PATTERN DETAIL  
FOR PERFORATED PANEL**

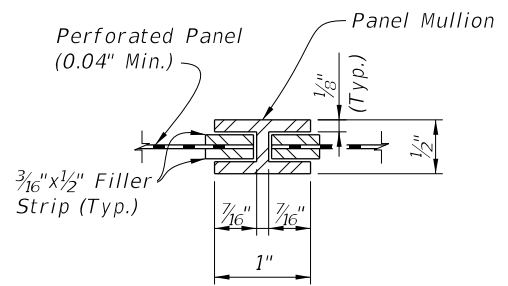

**SECTION C-C  
PANEL/SPLICE CONNECTION**

12/17/2015 11:43:07 AM

LAST REVISION 07/01/15	REVISION	DESCRIPTION:	 <b>FY 2016-17 DESIGN STANDARDS</b>	<b>ALUMINUM PEDESTRIAN/BICYCLE RAILING</b>	INDEX NO. <b>862</b>	SHEET NO. <b>8 of 9</b>
---------------------------	----------	--------------	---	--	-------------------------	----------------------------



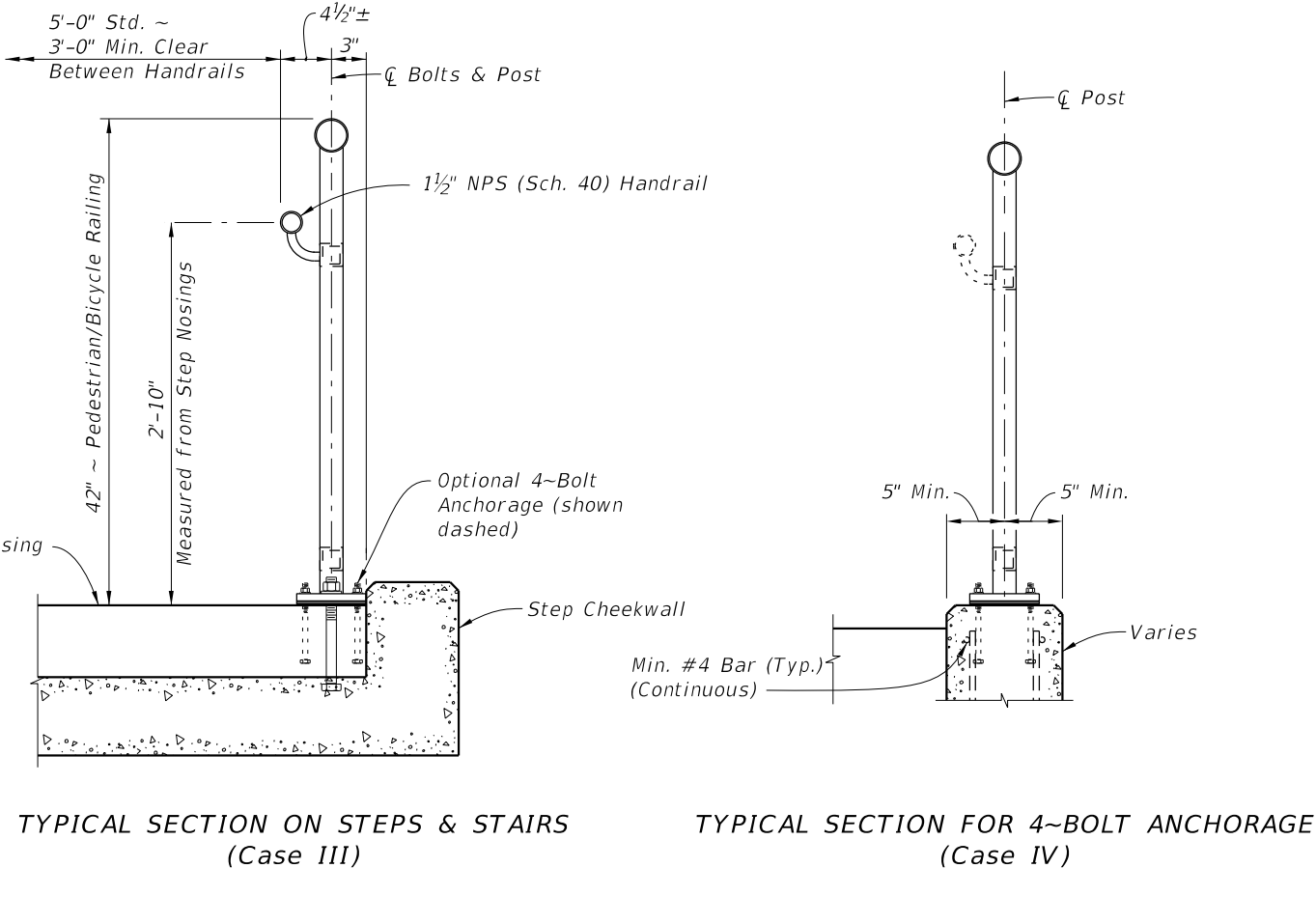
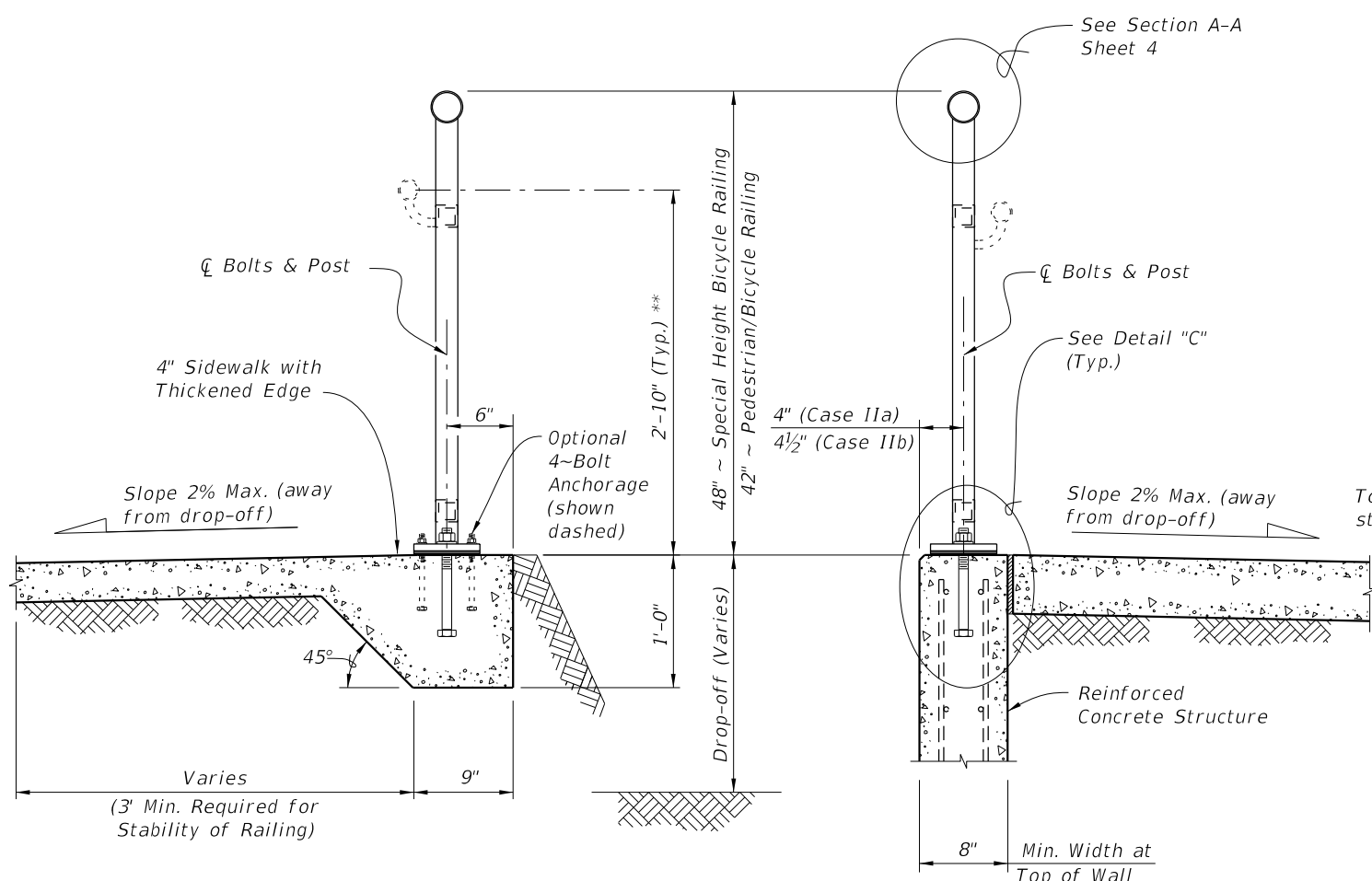

TYPICAL SECTION ON CONCRETE SIDEWALK (Case I)

TYPICAL SECTION ON RETAINING WALL (Case II)

TYPICAL SECTION ON STEPS & STAIRS (Case III)

TYPICAL SECTION FOR 4-BOLT ANCHORAGE (Case IV)

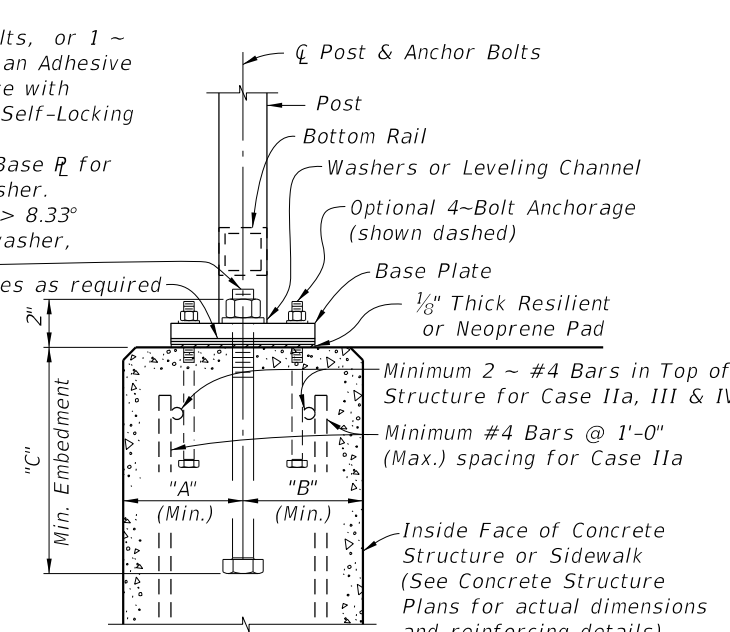
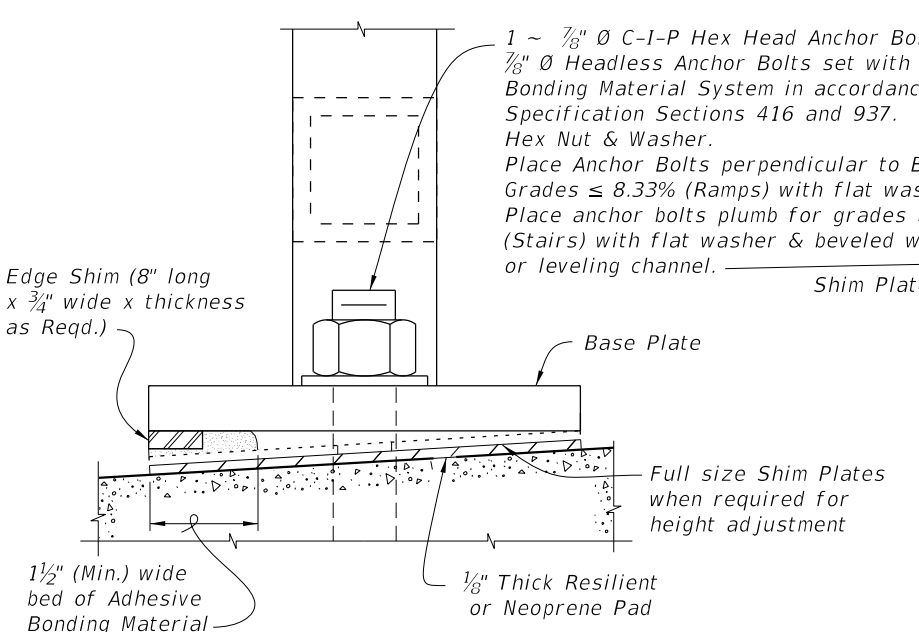

CASE	STRUCTURE TYPE	DIMENSIONS			ANCHOR LENGTH		ANCHOR SIZE
		"A" Edge Dist.	"B" Edge Dist.	"C" Embedment	C.I.P Hex Head Bolt	Adhesive Anchor	
		I	Unreinforced Concrete	6"	1'-2"	9"	
IIa	Reinforced Concrete	4"	4"	9"	10 1/2"	11"	7/8" Ø
IIb	Gravity Wall Index No. 6011	4 1/2"	3 1/2" @ top	1'-0" *	1'-1 1/2"	1'-2"	7/8" Ø
III	Step Cheekwall	4 1/2"	4 1/2"	9"	10 1/2"	11"	7/8" Ø
IV	Varies	5"	5"	5"	6 1/2"	7"	7/16" Ø

\* Embedment length "C" may be reduced to 9" for the 42" height railings for Case IIb, when the post spacing does not exceed 5'-0".

\*\* When required; measured from top of sidewalk (Typ.)

12/17/2015 11:43:09 AM