

△ Expansion Joints Shall Be Constructed Parallel To The Existing Transverse Pavement Joints On Rehabilitation Projects, And Parallel To The Standard Transverse Pavement Joints Shown In The Plans For New Construction.

**PLAN**

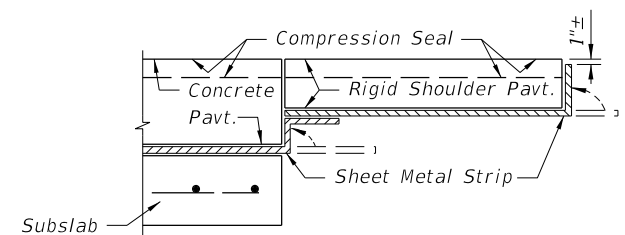

**WITH RIGID SHOULDER PAVEMENT**

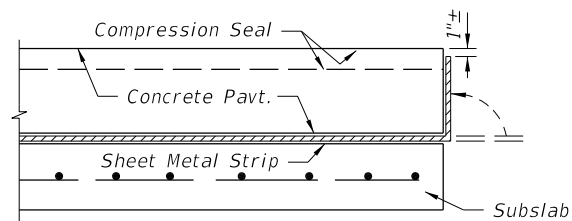

**WITH GRASSED SHOULDER OR FLEXIBLE SHOULDER PAVEMENT**

Note:  
Immediately prior to placing the seal, the joint shall be thoroughly cleaned of all foreign material. Immediately after the seal is placed, sheet metal strip shall be bent up against the pavement edge.

The sheet metal strip shall be a minimum 16 gage steel, 12" wide and shall be galvanized in accordance with ASTM A-526, Coating Designation G90.

**DETAIL SHOWING SHEET METAL STRIP**

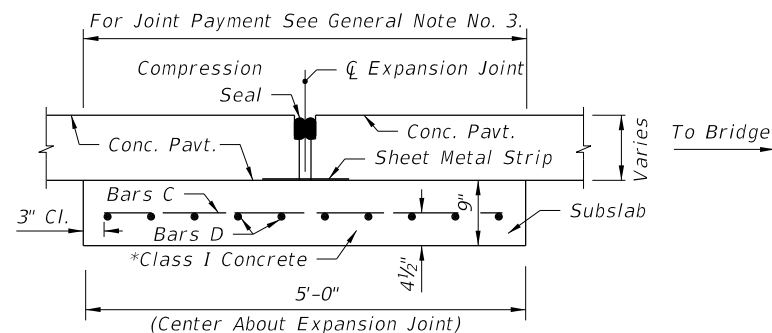

**SECTION AA  
EXPANSION JOINT**

REINFORCING STEEL				
Mark	Size	Spac.	No. Req.	Length
C	5	6"	Varies	4'-6"
D	5	6"	10	W Minus 6"

\* Finish surface smooth. Cure with heavy coating of wax base white pigmented curing compound. Apply second application immediately prior to placing pavement.

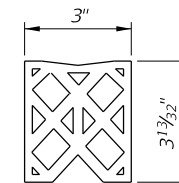
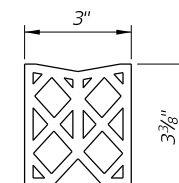
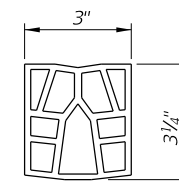

**OPTIONAL SEALS**

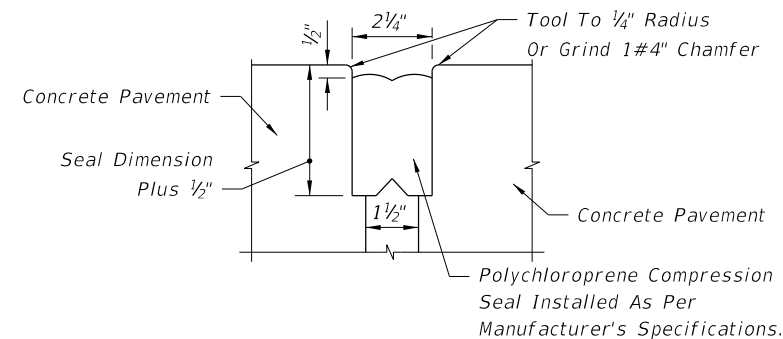

Note: All contacting surfaces between the compression seal and concrete shall be thoroughly coated with a lubricant-adhesive.

**JOINT DIMENSIONS  
COMPRESSION SEAL DETAIL**

**DESIGN NOTES**

1. For rehabilitation projects, the designer must indicate in the plans the number of slabs to be removed, the number of subslabs to be constructed/reconstructed, and the location of expansion joints.
2. Pay quantity of expansion joint to be calculated across pavement at right angles to the centerline of the roadway pavement. Shoulder pavement joint included.

**GENERAL NOTES**

1. The centerline of roadway and the centerline of bridge do not necessarily coincide. Prior to the placement of the expansion joint, the centerline of the roadway pavement shall be determined.
2. For information on other types of concrete pavement joints see Index No. 305.
3. Pay quantity for expansion joint is the length of joint to be constructed across the roadway and shoulder pavements, measured at right angles to the centerline of the roadway. Payment for expansion joint shall be full compensation for joint construction, including reinforced concrete subslab, sheet metal strip and compression seal, but, not including roadway pavement reconstruction associated with joint replacement or reconstruction. Expansion joint to be paid for under the contract unit price for Bridge Approach Expansion Joint, LF.

12/31/2015 9:34:32 AM

LAST REVISION 07/01/04	DESCRIPTION:	FDOT FY 2016-17 DESIGN STANDARDS	BRIDGE APPROACH EXPANSION JOINT CONCRETE PAVEMENT	INDEX NO. 306	SHEET NO. 1 of 1
---------------------------	--------------	--	--	------------------	---------------------