

**BUTT CONSTRUCTION JOINT**

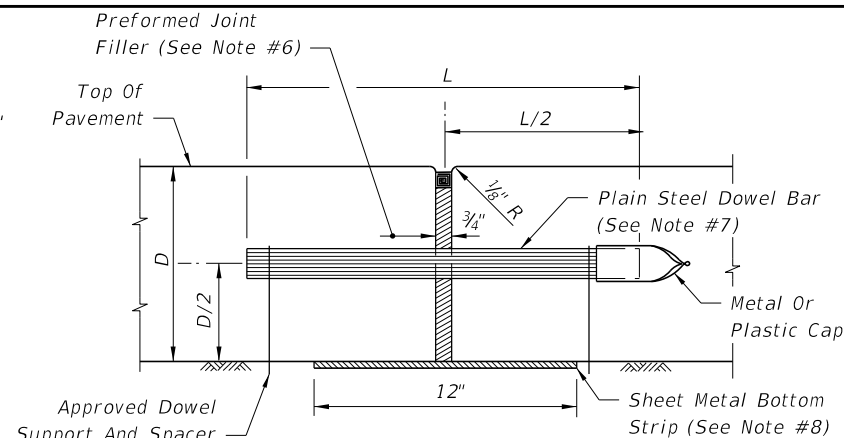

**EXPANSION JOINT**  
(See Note #6)

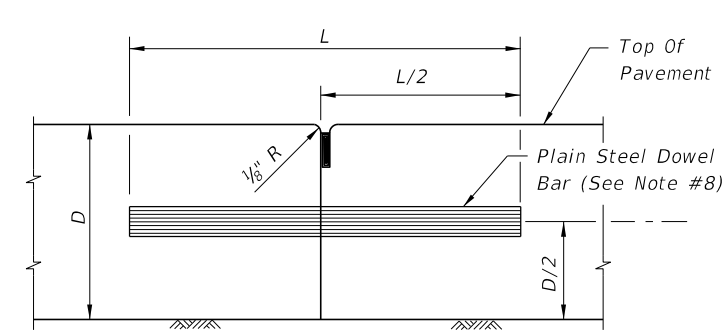

**BUTT CONSTRUCTION JOINT**  
(Used At Discountuance Of Work)

**NOTES:**

1. For joint seal dimensions see Sheet 2.
2. For slabs poured simultaneously, tie bars may be inserted in the plastic concrete by means approved by the Engineer.
3. For Longitudinal Joints:
  - A. Tie bars are deformed #4 or #5 reinforcing steel bars meeting the requirements of Specifications, Section 931.
  - B. Provide a standard load transfer tied joint with #4 bars 25" in length at 24" spacing or #5 bars 30" in length at 38" spacing.
4. Transverse joints are to be spaced at a maximum of 15'. Dowels are required at all transverse joints unless otherwise noted in the plans.
5. Expansion joints to be placed on approaches to bridges, at street intersections and other locations indicated in the plans.
6. Punch clean holes in preformed joint filler greater than bar diameter.
7. Coat and lubricate plain steel dowel bars in accordance with Specifications, Section 350.
8. Sheet metal bottom strips in accordance with Specifications, Section 931.

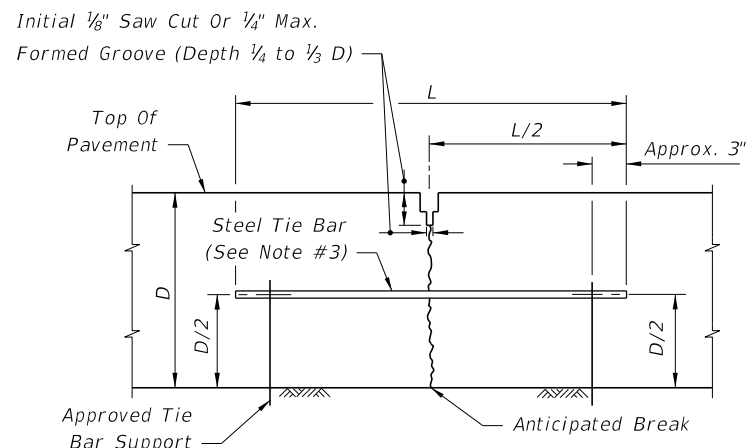

**LANE-TIE JOINT**  
(See Note #2)

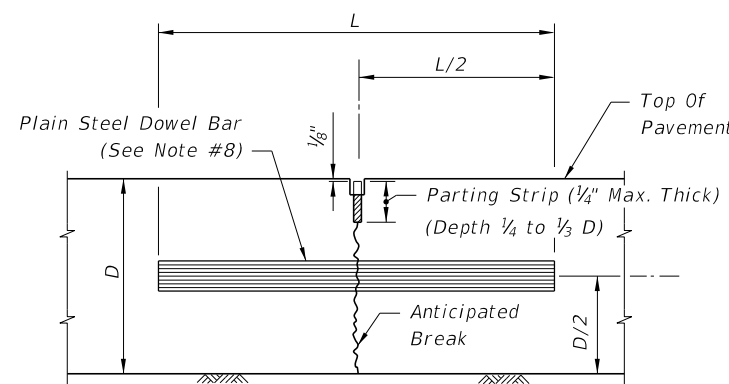

**CONTRACTION JOINT**  
(Vibro Case Method)

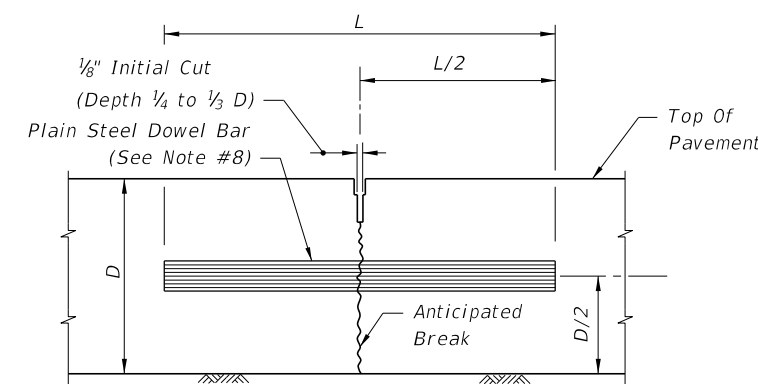

**CONTRACTION JOINT**  
(Sawed Method)

=====**LONGITUDINAL JOINTS**=====

=====**TRANSVERSE JOINTS**=====

| <b>DOWELS (LENGTH 18")</b> |          |
|----------------------------|----------|
| Pavement Thickness "D"     | Diameter |
| 6"-6½"                     | ¾"       |
| 7"-8½"                     | 1"       |
| 9"-10½"                    | 1¼"      |
| ≥11"                       | 1½"      |

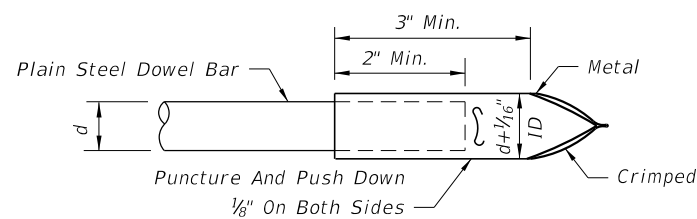

**METAL**

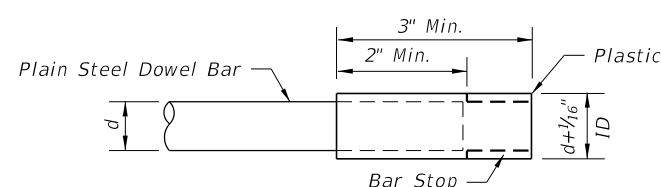

**PLASTIC**

=====**DOWEL BARS CAPS**=====

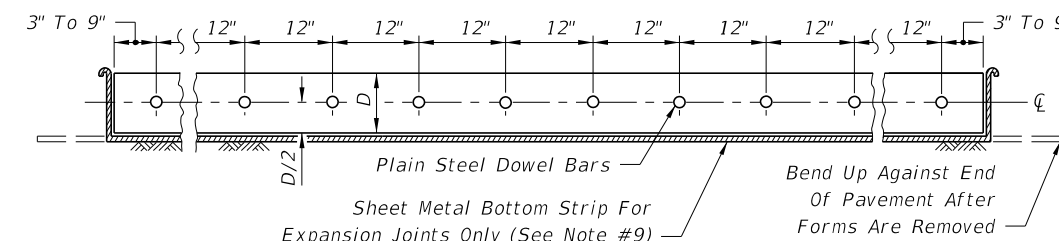

=====**DOWEL BAR LAYOUT**=====

12/31/2015 9:34:12 AM

|                           |          |              |
|---------------------------|----------|--------------|
| LAST REVISION<br>01/01/16 | REVISION | DESCRIPTION: |
|---------------------------|----------|--------------|

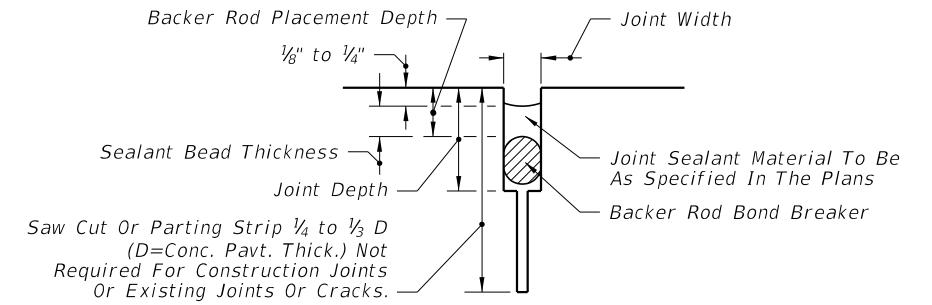
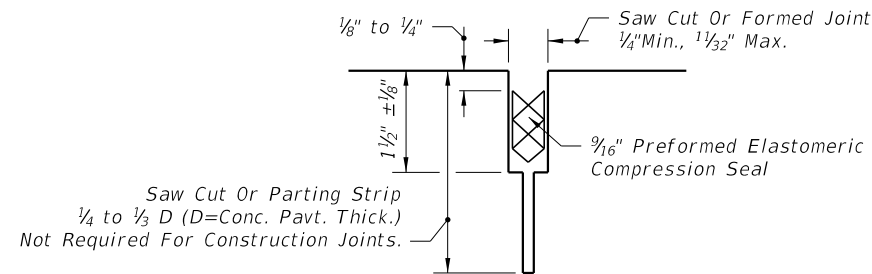
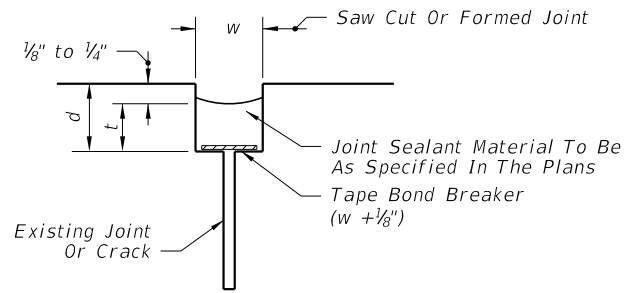

Note: Dimension w will be shown in the plans or established by the Engineer based on field conditions. Dimension d will be constructed so that the shape factor w/t has a maximum value of 2.0 and a minimum value of 1.0.

FOR NEW PROJECTS  
**PREFORMED ELASTOMERIC COMPRESSION SEAL**

FOR NEW AND REHABILITATION PROJECTS  
**BACKER ROD BOND BREAKER**

FOR REHABILITATION PROJECTS  
**TAPE BOND BREAKER**

**CONCRETE-CONCRETE JOINTS**

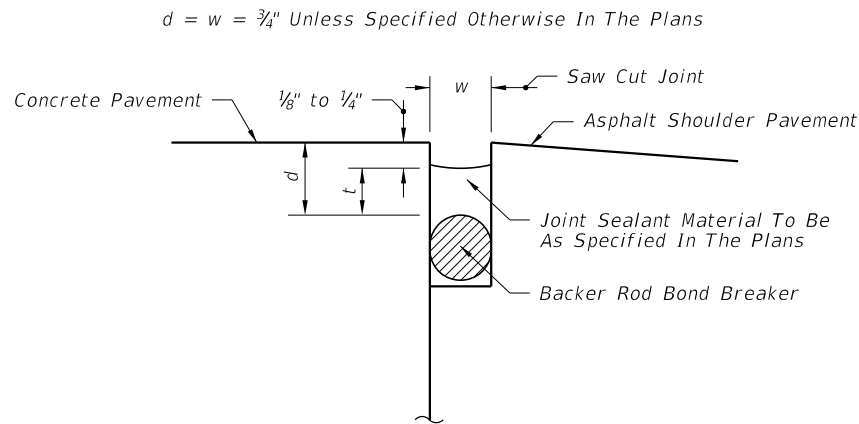

**BACKER ROD BOND BREAKER**

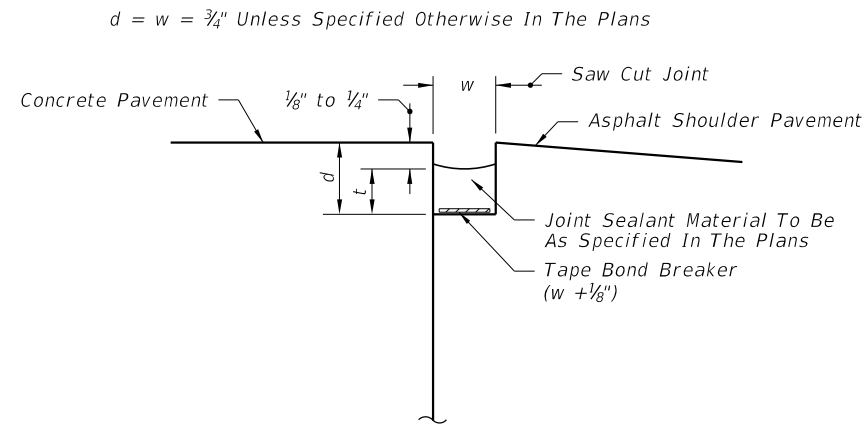

**TAPE BOND BREAKER**

FOR NEW AND REHABILITATION PROJECTS;  
 EITHER TAPE OR BACKER ROD BOND BREAKER REQUIRED;  
 SHOULDER MUST BE REPAIRED IF PROPER JOINT SHAPE  
 CAN NOT BE ATTAINED

**CONCRETE-ASPHALT SHOULDER JOINTS**

**JOINT SEAL DIMENSIONS**

| <b>BACKER ROD BOND BREAKER<br/>(CONCRETE-CONCRETE JOINTS)</b> |                        |                 |                     |                            |
|---|------------------------|-----------------|---------------------|----------------------------|
| JOINT DIMENSIONS (INCHES)                                     |                        |                 |                     |                            |
| JOINT WIDTH   | SEALANT BEAD THICKNESS | BACKER ROD DIA. | MINIMUM JOINT DEPTH | BACKER ROD PLACEMENT DEPTH |
| 1/4   | 1/4                    | 3/8             | 1                   | 1/2                        |
| 3/8   | 1/4                    | 1/2             | 1 1/4               | 1/2                        |
| 1/2   | 1/4                    | 5/8             | 1 1/4               | 1/2                        |
| 5/8   | 5/16                   | 3/4             | 1 1/2               | 9/16                       |
| 3/4   | 3/8                    | 1               | 1 3/4               | 5/8                        |
| 7/8   | 7/16                   | 1 1/8           | 1 3/4               | 1 1/16                     |
| 1   | 1/2                    | 1 1/4           | 2                   | 3/4                        |
| >1  | 1/2                    | 1 1/4+          | 2+                  | 3/4                        |

Unless otherwise indicated on the plans the joint width for new construction will be 1/4" for construction joints, 3/8" for all other joints.

For rehabilitation projects the joint width will be shown on the plans or established by the Engineer based on field conditions.

12/31/2015 9:34:13 AM

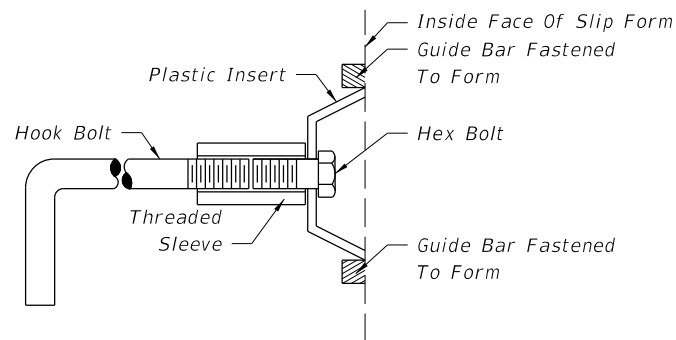

Note: After the concrete has set to the extent that the keyway will retain its shape, the hex bolt and plastic insert shall be removed. The remaining portion of the hook bolt assembly shall be installed immediately prior to placing of concrete in the adjacent lane.

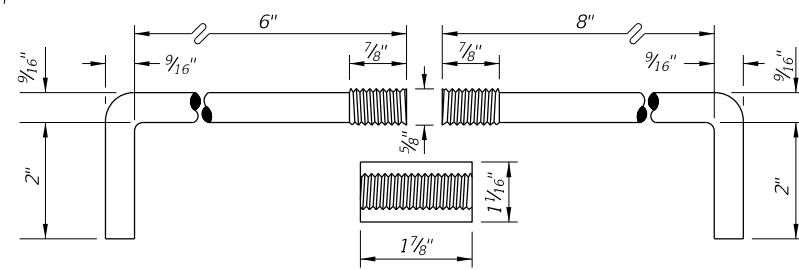

Anchor bolts shall be Grade C in accordance with ASTM A 307.

Threaded sleeves shall develop the full strength of the bolt and meet the material and thread requirements of ASTM A 563.

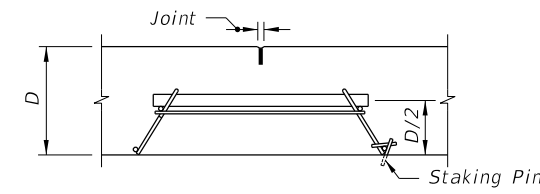

SECTION AA

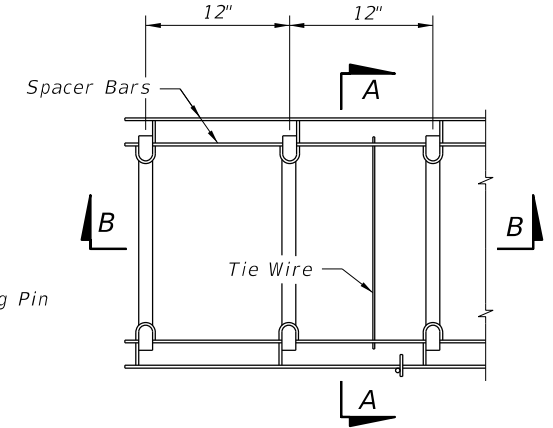

TOP VIEW

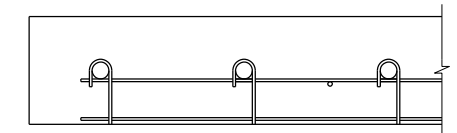

SECTION BB

CONTRACTION ASSEMBLY

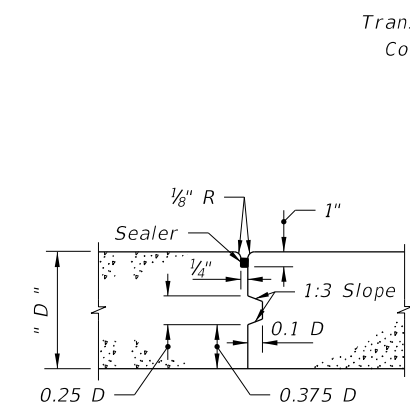

KEYED JOINT

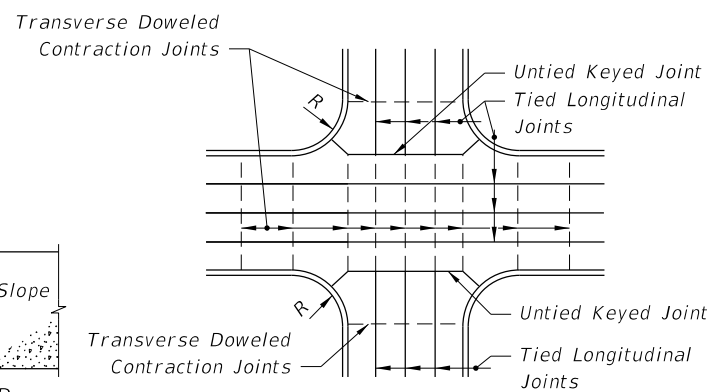

JOINT LAYOUT AT THRU INTERSECTION

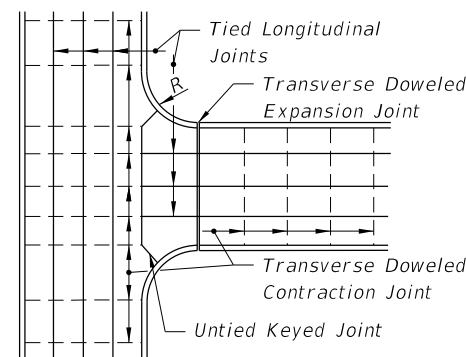

JOINT LAYOUT AT 'T' INTERSECTIONS

JOINT ARRANGEMENT

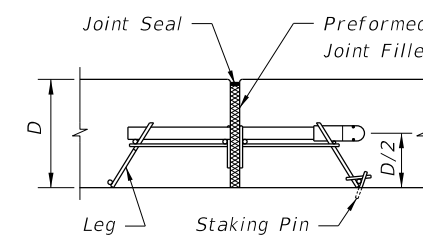

SECTION CC

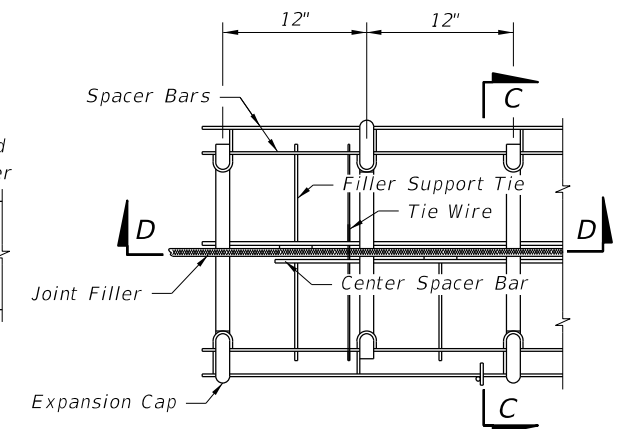

TOP VIEW

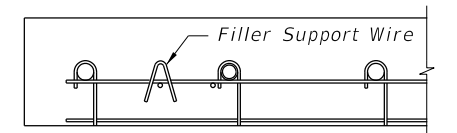

SECTION DD

EXPANSION ASSEMBLY

NOTES

1. Longitudinal joints will not be required for single lane pavement 14' or less in width. For entrance and exit ramp joint details, see Sheet 4.
2. Arrangement of longitudinal joints are to be as directed by the Engineer.
3. All manholes, meter boxes and other projections into the pavement shall be boxed-in with 1/2" preformed expansion joint material.

Note: Proprietary contraction and expansion assemblies may be used. Products shall be introduced to the State Construction Office in accordance with section (C) of the Product Evaluation Procedure.

12/3/2015 9:34:14 AM

|                           |          |              |  |                                |                          |                  |                     |
|---------------------------|----------|--------------|--|--------------------------------|--------------------------|------------------|---------------------|
| LAST REVISION<br>07/01/00 | REVISION | DESCRIPTION: |  | FY 2016-17<br>DESIGN STANDARDS | CONCRETE PAVEMENT JOINTS | INDEX NO.<br>305 | SHEET NO.<br>3 of 4 |
|---------------------------|----------|--------------|--|--------------------------------|--------------------------|------------------|---------------------|

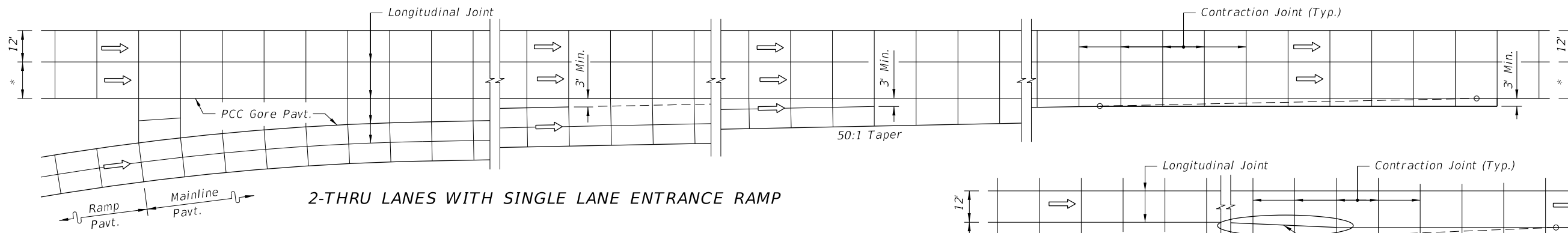

2-THRU LANES WITH SINGLE LANE ENTRANCE RAMP

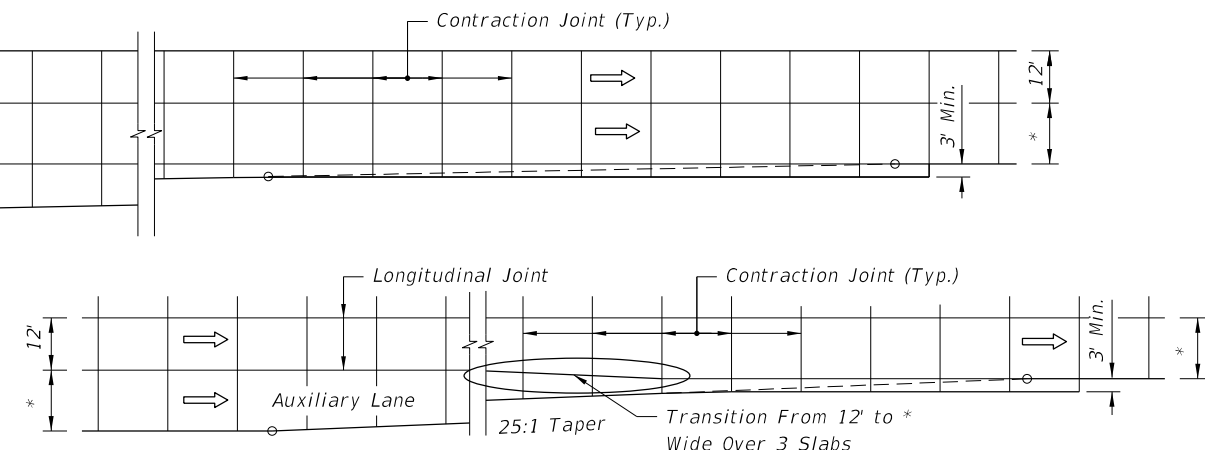

ENTRANCE TAPER WITH AUXILIARY LANE

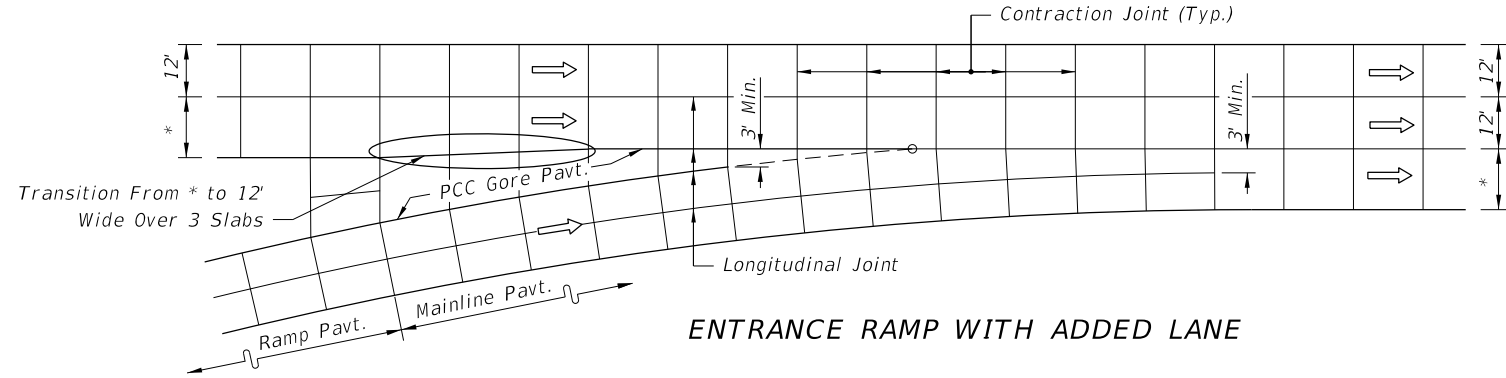

ENTRANCE RAMP WITH ADDED LANE

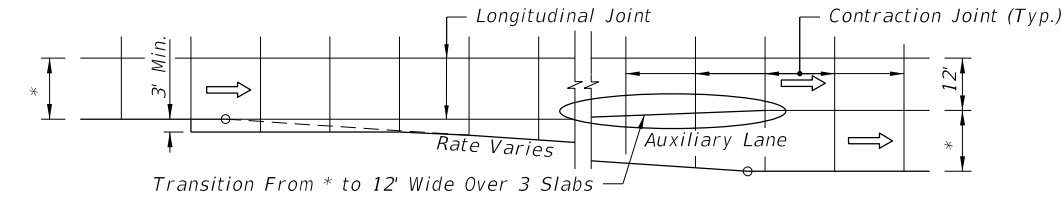

EXIT TAPER WITH AUXILIARY LANE

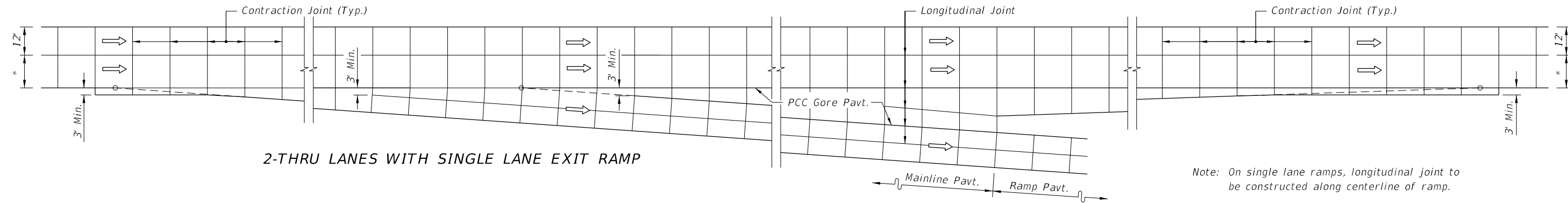

2-THRU LANES WITH SINGLE LANE EXIT RAMP

Note: On single lane ramps, longitudinal joint to be constructed along centerline of ramp.

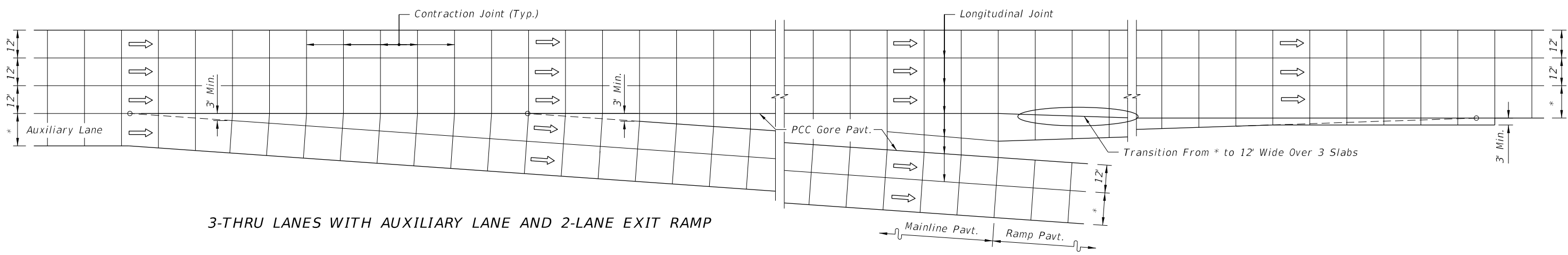

3-THRU LANES WITH AUXILIARY LANE AND 2-LANE EXIT RAMP

JOINT LAYOUT AT ENTRANCE AND EXIT RAMP TERMINALS

\* 13' with tied Concrete Shoulders or 14' with Asphalt Shoulders.

12/3/2015 9:34:15 AM

|                           |          |              |   |                          |                  |                     |
|---------------------------|----------|--------------|---|--------------------------|------------------|---------------------|
| LAST REVISION<br>07/01/09 | REVISION | DESCRIPTION: |  FY 2016-17<br>DESIGN STANDARDS | CONCRETE PAVEMENT JOINTS | INDEX NO.<br>305 | SHEET NO.<br>4 of 4 |
|---------------------------|----------|--------------|---|--------------------------|------------------|---------------------|