

**TYPICAL BOX SECTION (TYPE 2)  
DESIGN EARTH COVER 2' OR GREATER  
(Option 1 Reinforcing Configuration Shown)**

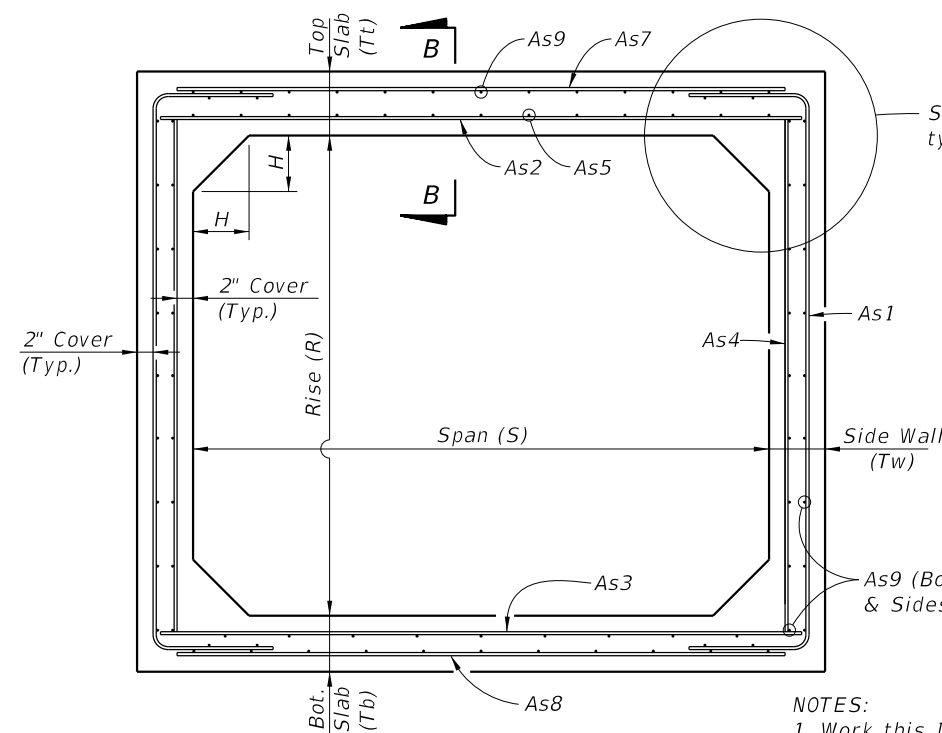

**TYPICAL BOX SECTION (TYPE 1)  
DESIGN EARTH COVER LESS THAN 2'  
(Option 1 Reinforcing Configuration Shown)**

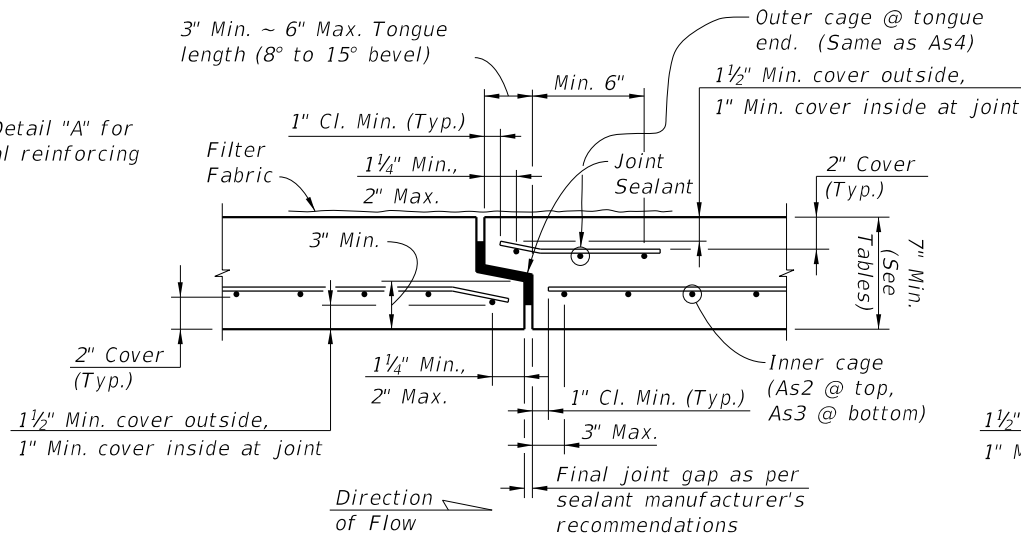

**SECTION A-A**

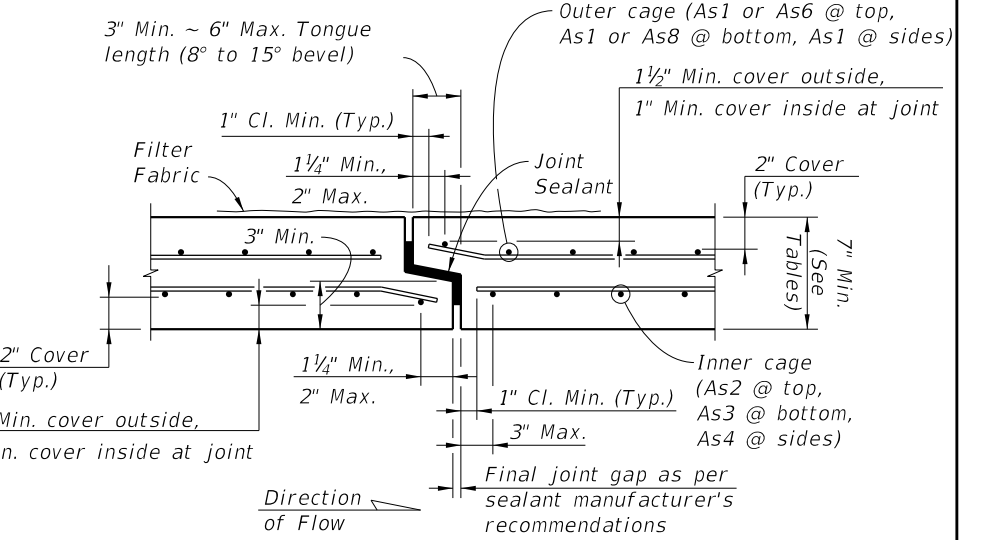

**SECTION B-B  
TYPICAL SECTION THRU JOINT**

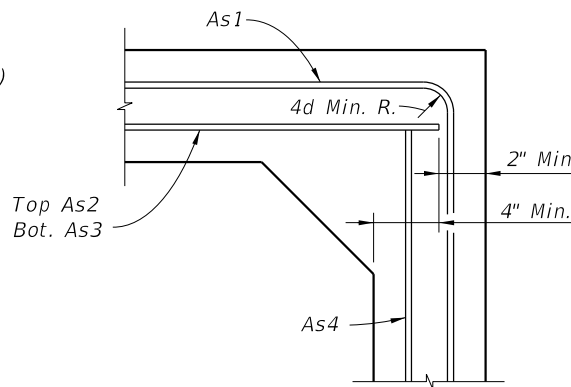

**DETAIL "A"  
(OPTION 1)**

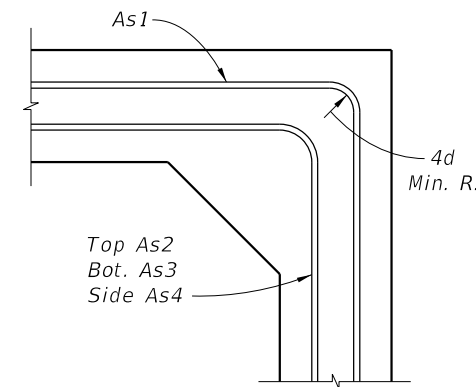

**DETAIL "A"  
(OPTION 2)**

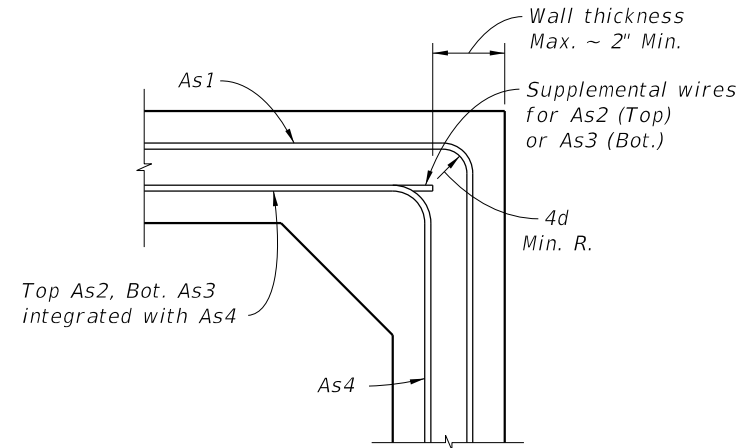

**DETAIL "A"  
(OPTION 3)**

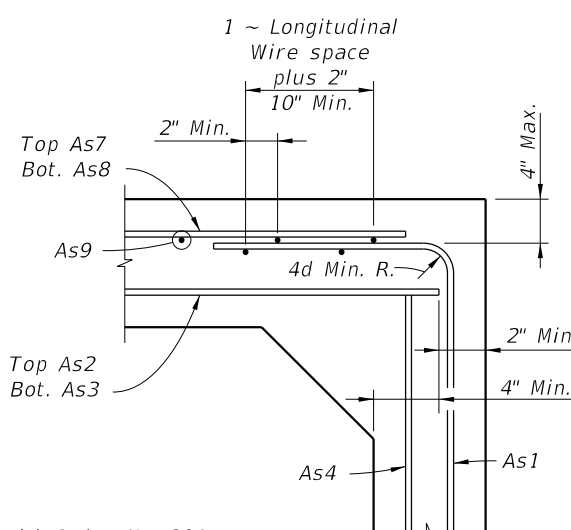

**DETAIL "B"  
(OPTION 1)**

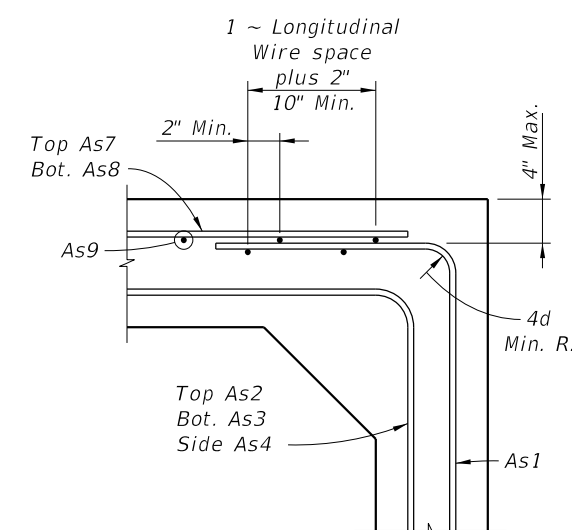

**DETAIL "B"  
(OPTION 2)**

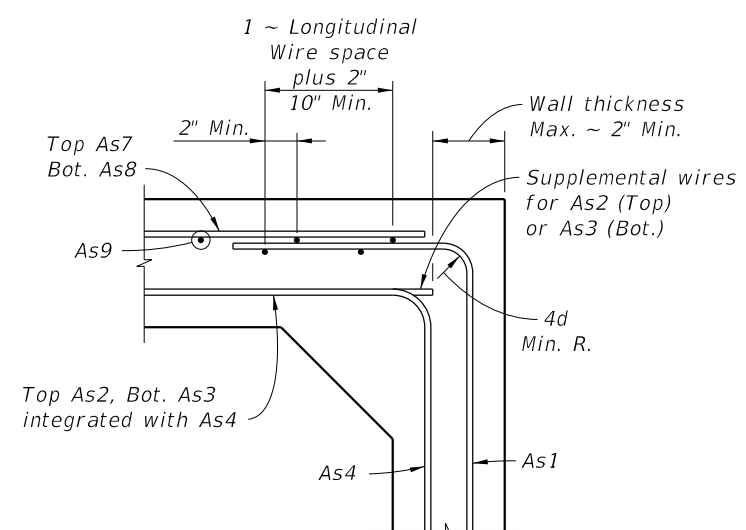

**DETAIL "B"  
(OPTION 3)**

**NOTES:**  
1. Work this Index with Index No. 291.  
2. See sheets 2 thru 5 for dimensions and areas of reinforcement.

**STANDARD PRECAST BOX CULVERT WITH 2" CONCRETE COVER**

12/17/2015 11:13:29 AM

LAST REVISION 07/01/13	REVISION	DESCRIPTION:	 <b>FY 2016-17 DESIGN STANDARDS</b>	<b>STANDARD PRECAST CONCRETE BOX CULVERTS</b>	INDEX NO. <b>292</b>	SHEET NO. <b>1 of 14</b>
---------------------------	----------	--------------	--	---	-------------------------	-----------------------------

**GENERAL NOTES:**

1. These precast designs may be substituted for cast-in-place box culverts designed to AASHTO LRFD Bridge Design Specifications, 4th Edition. Designs are based on the design criteria shown in FDOT Structures Design Guidelines.
2. Loading: HL-93 & any fill heights between the minimum & maximum shown.
3. Only one design of precast box culvert is to be used for any installation.
4. Reinforcing steel must consist of smooth or deformed welded wire reinforcement (WWR) meeting the requirements of Specification Section 931. Longitudinal reinforcement may consist of reinforcing bars meeting the requirements of Specification Section 931. Minimum cover must be 2" for slightly or moderately aggressive environments or 3" for extremely aggressive environments, unless otherwise shown. The spacing of circumferential wires must not be less than 2" nor more than 4". The spacing of longitudinal wires or bars must not be more than 8".
5. As9 longitudinal wires must have a minimum cross-sectional area of 40% of the circumferential wires, but not less than a W2.5 or D4.0 for WWR, or #3 bars for deformed bars.
6. Welding of reinforcement must be limited to the locations shown in ASTM C1577 and in accordance with ANSI/AWS D1.4 "Structural Welding Code - Reinforcing Steel".
7. For alternate reinforcing configuration Options 2 and 3 shown in Detail "A" and "B" (Sheet 1), As1 may be extended to the middle of either slab and lap spliced with As7 and As8. As4 may be lap spliced at any location or connected to As2 or As3 at corners by welding.
8. Haunch dimensions may vary between the minimum and maximum dimensions shown in the Design Tables but only one haunch dimension must be used within the full length of the box culvert installation.

9. Submittal of redesign calculations are not required for any increase to the slab and/or wall thickness when the minimum reinforcement areas shown in the Design Tables are provided.
10. For Design Earth Cover greater than 10 feet, the Contractor may interpolate the required areas of reinforcement and slab or wall thickness. Interpolated areas of reinforcement, slab or wall thickness must be approved by the Engineer.
11. Minimum length of precast box segments is 4 feet and maximum length is 16 feet.
12. See Index No. 291 for connections to wingwalls, headwalls and other general details.

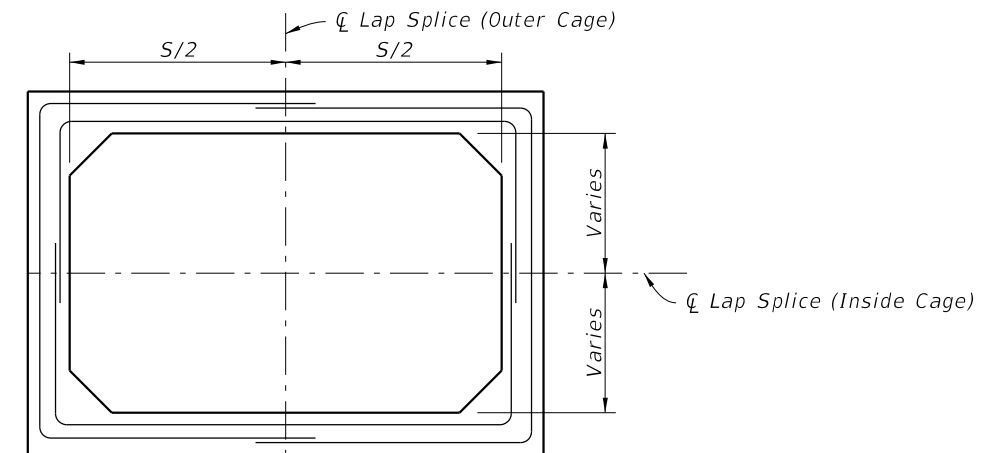

**SCHEMATIC OF LAP SPLICE LOCATIONS FOR OPTION 2 & 3 REINFORCING CONFIGURATIONS**

SPAN x RISE (S) (R) (Ft.)	SLAB / WALL THICKNESS				DESIGN EARTH COVER ABOVE TOP SLAB	REINFORCEMENT AREAS (sq. in./Ft.)								As1 EXT. LENGTH (M) (in.)			
	TOP (Tt) (in.)	BOT. (Tb) (in.)	SIDE (Tw) (in.)	HAUNCH (H) (in.)		As1	As2	As3	As4	As5	As7	As8	As9				
3' x 3'	7	7	7	4 to	0.33' - <2'	0.17	0.29	0.21	0.17	0.17	0.17	0.17	See General Note 5	-			
					2' - <3'	0.13	0.28	0.21	0.09	-	-	-		31			
					3' - <5'	0.09	0.17	0.17	0.09	-	-	-		31			
					5' - 10'	0.09	0.17	0.17	0.09	-	-	-		31			
					15'	0.09	0.17	0.17	0.09	-	-	-		31			
				8	20'	0.12	0.17	0.17	0.09	-	-	-		31			
				25'	0.14	0.18	0.18	0.09	-	-	-	31					
				30'	0.17	0.21	0.22	0.09	-	-	-	31					
				35'	0.19	0.25	0.25	0.09	-	-	-	31					
				4' x 3'	7	7	7	4 to	0.33' - <2'	0.19	0.38	0.26		0.17	0.19	0.17	0.19
2' - <3'	0.19	0.38	0.26						0.09	-	-	-	38				
3' - <5'	0.14	0.20	0.22						0.09	-	-	-	38				
5' - 10'	0.11	0.17	0.17						0.09	-	-	-	38				
15'	0.15	0.17	0.18						0.09	-	-	-	38				
8	20'	0.20	0.23					0.23	0.09	-	-	-	38				
25'	0.24	0.28	0.29					0.09	-	-	-	38					
30'	0.29	0.34	0.35					0.09	-	-	-	38					
4' x 4'	7	7	7					4 to	0.33' - <2'	0.19	0.41	0.28	0.17	0.21	0.17	0.19	-
									2' - <3'	0.19	0.41	0.28	0.09	-	-	-	38
				3' - <5'	0.14	0.21	0.24		0.09	-	-	-	38				
				5' - 10'	0.12	0.17	0.17		0.09	-	-	-	38				
				15'	0.16	0.19	0.20		0.09	-	-	-	38				
				8	20'	0.21	0.25	0.25	0.09	-	-	-	38				
				25'	0.26	0.31	0.32	0.09	-	-	-	38					
				30'	0.31	0.37	0.38	0.09	-	-	-	38					

SPAN x RISE (S) (R) (Ft.)	SLAB / WALL THICKNESS				DESIGN EARTH COVER ABOVE TOP SLAB	REINFORCEMENT AREAS (sq. in./Ft.)								As1 EXT. LENGTH (M) (in.)			
	TOP (Tt) (in.)	BOT. (Tb) (in.)	SIDE (Tw) (in.)	HAUNCH (H) (in.)		As1	As2	As3	As4	As5	As7	As8	As9				
3' x 3'	8	8	8	4 to	0.33' - <2'	0.20	0.26	0.32	0.20	0.20	0.20	0.20	See General Note 5	-			
					2' - <3'	0.16	0.25	0.31	0.10	-	-	-		31			
					3' - <5'	0.10	0.20	0.20	0.10	-	-	-		31			
					5' - 10'	0.10	0.20	0.20	0.10	-	-	-		31			
					15'	0.10	0.20	0.20	0.10	-	-	-		31			
				8	20'	0.10	0.20	0.20	0.10	-	-	-		31			
				25'	0.11	0.20	0.20	0.10	-	-	-	31					
				30'	0.13	0.20	0.20	0.10	-	-	-	31					
				35'	0.15	0.21	0.21	0.10	-	-	-	31					
				4' x 3'	8	8	8	4 to	0.33' - <2'	0.20	0.31	0.22		0.20	0.20	0.20	0.20
2' - <3'	0.12	0.31	0.22						0.10	-	-	-	38				
3' - <5'	0.12	0.20	0.20						0.10	-	-	-	38				
5' - 10'	0.10	0.20	0.20						0.10	-	-	-	38				
15'	0.12	0.20	0.20						0.10	-	-	-	38				
8	20'	0.16	0.20					0.20	0.10	-	-	-	38				
25'	0.19	0.24	0.24					0.10	-	-	-	38					
30'	0.22	0.28	0.29					0.10	-	-	-	38					
4' x 4'	8	8	8					4 to	0.33' - <2'	0.20	0.33	0.24	0.20	0.20	0.20	0.20	-
									2' - <3'	0.17	0.33	0.24	0.10	-	-	-	38
				3' - <5'	0.12	0.20	0.20		0.10	-	-	-	38				
				5' - 10'	0.10	0.20	0.20		0.10	-	-	-	38				
				15'	0.13	0.20	0.20		0.10	-	-	-	38				
				8	20'	0.16	0.21	0.22	0.10	-	-	-	38				
				25'	0.20	0.26	0.27	0.10	-	-	-	38					
				30'	0.23	0.31	0.32	0.10	-	-	-	38					

NOTES: 1. See Sheet 1 for Reinforcing Details and dimension locations.  
2. See Sheet 14 for WWR Bending Diagram.

12/17/2015 11:13:29 AM

12/17/2015 11:13:30 AM

TABLE 2A - STANDARD PRECAST BOX CULVERT DESIGNS (2" COVER) - 5' & 6' SPANS

SPAN x RISE (S) (R) (Ft.)	SLAB / WALL THICKNESS				DESIGN EARTH COVER ABOVE TOP SLAB	REINFORCEMENT AREAS (sq. in./Ft.)								As1 EXT. LENGTH (M) (in.)				
	TOP (Tt) (in.)	BOT. (Tb) (in.)	SIDE (Tw) (in.)	HAUNCH (H) (in.)		As1	As2	As3	As4	As5	As7	As8	As9					
5' x 3'	7	7	7	4	0.33' - <2'	0.31	0.48	0.42	0.17	0.21	0.23	0.31	-	See General Note 5				
					2' - <3'	0.31	0.48	0.42	0.09	-	-	-	45					
					3' - <5'	0.20	0.27	0.27	0.09	-	-	-	36					
					5' - 10'	0.17	0.19	0.21	0.09	-	-	-	36					
					15'	0.24	0.25	0.25	0.09	-	-	-	35					
	8	20'	0.32	0.33	0.33	0.09	-	-	-	35								
		25'	0.39	0.41	0.42	0.09	-	-	-	35								
		30'	0.47	0.50	0.50	0.09	-	-	-	35								
		5' x 4'	7	7	7	4	0.33' - <2'	0.30	0.51	0.45	0.17	0.23	0.21		0.30	-		
							2' - <3'	0.30	0.51	0.45	0.09	-	-		-	45		
3' - <5'	0.18						0.30	0.29	0.09	-	-	-	45					
5' - 10'	0.17						0.21	0.23	0.09	-	-	-	36					
15'	0.24						0.27	0.28	0.09	-	-	-	35					
8	20'		0.31	0.36	0.37	0.09	-	-	-	35								
	25'		0.39	0.45	0.46	0.09	-	-	-	35								
	30'		0.46	0.55	0.56	0.09	-	-	-	35								
	5' x 5'		7	7	7	4	0.33' - <2'	0.30	0.53	0.48	0.17	0.24	0.21	0.30	-			
							2' - <3'	0.29	0.53	0.48	0.09	-	-	-	45			
3' - <5'		0.19					0.31	0.31	0.09	-	-	-	45					
5' - 10'		0.19					0.22	0.25	0.09	-	-	-	45					
15'		0.26					0.29	0.31	0.09	-	-	-	36					
8		20'	0.34	0.39	0.40	0.09	-	-	-	35								
		25'	0.41	0.49	0.50	0.09	-	-	-	35								
		30'	0.49	0.59	0.61	0.09	-	-	-	35								
		6' x 3'	7.5	7	7	4	0.33' - <2'	0.39	0.54	0.48	0.17	0.22	0.25	0.39	-			
							2' - <3'	0.39	0.58	0.49	0.09	-	-	-	43			
7	7		7	12	3' - <5'		0.28	0.36	0.36	0.09	-	-	-	39				
					5' - 10'		0.25	0.26	0.28	0.09	-	-	-	39				
					15'		0.36	0.34	0.34	0.09	-	-	-	38				
8	8		7		20'	0.47	0.46	0.46	0.09	-	-	-	38					
					25'	0.59	0.57	0.55	0.09	-	-	-	38					
				30'	0.60	0.64	0.64	0.09	-	-	-	38						
6' x 4'	7.5		7	7	4	0.33' - <2'	0.37	0.58	0.52	0.17	0.24	0.23	0.37	-				
						2' - <3'	0.37	0.61	0.53	0.09	-	-	-	43				
		3' - <5'				0.26	0.39	0.39	0.09	-	-	-	39					
		5' - 10'				0.24	0.28	0.31	0.09	-	-	-	39					
		15'				0.35	0.37	0.38	0.09	-	-	-	38					
	8	8	7	12	20'	0.46	0.50	0.50	0.09	-	-	-	38					
					25'	0.56	0.63	0.60	0.09	-	-	-	38					
					30'	0.58	0.69	0.69	0.09	-	-	-	38					
					6' x 5'	7.5	7	7	4	0.33' - <2'	0.36	0.60	0.56	0.17	0.25	0.22	0.36	-
										2' - <3'	0.36	0.64	0.56	0.09	-	-	-	43
3' - <5'	0.26	0.410	0.42	0.09						-	-	-	43					
5' - 10'	0.25	0.30	0.33	0.09						-	-	-	39					
15'	0.34	0.40	0.41	0.09						-	-	-	38					
8	8	8	12	20'		0.46	0.54	0.54	0.09	-	-	-	38					
				25'		0.56	0.67	0.65	0.09	-	-	-	38					
				30'		0.60	0.74	0.74	0.09	-	-	-	38					
				6' x 6'		7.5	7	7	4	0.33' - <2'	0.36	0.63	0.59	0.17	0.26	0.22	0.36	-
										2' - <3'	0.35	0.67	0.59	0.09	-	-	-	52
3' - <5'	0.27	0.43	0.44		0.09					-	-	-	52					
5' - 10'	0.27	0.32	0.35		0.09					-	-	-	43					
15'	0.38	0.43	0.44		0.09					-	-	-	39					
8	8	7	12		20'	0.50	0.57	0.59	0.09	-	-	-	39					
					25'	0.60	0.72	0.70	0.09	-	-	-	38					
					30'	0.67	0.78	0.79	0.09	-	-	-	38					

TABLE 2B - STANDARD PRECAST BOX CULVERT DESIGNS (2" COVER) - 5' & 6' SPANS

SPAN x RISE (S) (R) (Ft.)	SLAB / WALL THICKNESS				DESIGN EARTH COVER ABOVE TOP SLAB	REINFORCEMENT AREAS (sq. in./Ft.)								As1 EXT. LENGTH (M) (in.)		
	TOP (Tt) (in.)	BOT. (Tb) (in.)	SIDE (Tw) (in.)	HAUNCH (H) (in.)		As1	As2	As3	As4	As5	As7	As8	As9			
5' x 3'	8	8	8	4	0.33' - <2'	0.26	0.39	0.36	0.20	0.20	0.20	0.26	-	See General Note 5		
					2' - <3'	0.26	0.39	0.36	0.10	-	-	-	45			
					3' - <5'	0.16	0.23	0.24	0.10	-	-	-	36			
					5' - 10'	0.13	0.20	0.20	0.10	-	-	-	36			
					15'	0.19	0.21	0.22	0.10	-	-	-	35			
	8	20'	0.24	0.28	0.28	0.10	-	-	-	35						
		25'	0.30	0.34	0.35	0.10	-	-	-	35						
		30'	0.36	0.41	0.41	0.10	-	-	-	35						
		5' x 4'	8	8	8	4	0.33' - <2'	0.25	0.42	0.38	0.20	0.20	0.20		0.25	-
							2' - <3'	0.25	0.42	0.38	0.10	-	-		-	45
3' - <5'	0.16						0.25	0.25	0.10	-	-	-	45			
5' - 10'	0.13						0.20	0.20	0.10	-	-	-	36			
15'	0.19						0.23	0.24	0.10	-	-	-	35			
8	20'		0.24	0.30	0.31	0.10	-	-	-	35						
	25'		0.30	0.37	0.38	0.10	-	-	-	35						
	30'		0.35	0.45	0.46	0.10	-	-	-	35						
	5' x 5'		8	8	8	4	0.33' - <2'	0.25	0.44	0.41	0.20	0.20	0.20	0.25	-	
							2' - <3'	0.25	0.44	0.41	0.10	-	-	-	45	
3' - <5'		0.16					0.26	0.27	0.10	-	-	-	45			
5' - 10'		0.15					0.20	0.22	0.10	-	-	-	45			
15'		0.20					0.25	0.26	0.10	-	-	-	36			
8		20'	0.26	0.32	0.33	0.10	-	-	-	35						
		25'	0.32	0.40	0.41	0.10	-	-	-	35						
		30'	0.37	0.48	0.49	0.10	-	-	-	35						
		6' x 3'	8	8	8	4	0.33' - <2'	0.32	0.47	0.41	0.20	0.20	0.25	0.32	-	
							2' - <3'	0.32	0.47	0.41	0.10	-	-	-	43	
3' - <5'	0.23						0.30	0.31	0.10	-	-	-	39			
5' - 10'	0.19						0.22	0.24	0.10	-	-	-	39			
15'	0.28						0.29	0.29	0.10	-	-	-	38			
12	20'		0.36	0.38	0.38	0.10	-	-	-	38						
	25'		0.45	0.47	0.47	0.10	-	-	-	38						
	30'		0.54	0.57	0.57	0.10	-	-	-	38						
	6' x 4'		8	8	8	4	0.33' - <2'	0.31	0.50	0.44	0.20	0.21	0.23	0.31	-	
							2' - <3'	0.31	0.50	0.44	0.10	-	-	-	43	
3' - <5'		0.23					0.32	0.34	0.10	-	-	-	39			
5' - 10'		0.19					0.24	0.26	0.10	-	-	-	39			
15'		0.27					0.31	0.32	0.10	-	-	-	38			
12		20'	0.35	0.41	0.41	0.10	-	-	-	38						
		25'	0.43	0.51	0.51	0.10	-	-	-	38						
		30'	0.52	0.62	0.62	0.10	-	-	-	38						
		6' x 5'	8	8	8	4	0.33' - <2'	0.30	0.52	0.47	0.20	0.22	0.22	0.30	-	
							2' - <3'	0.30	0.52	0.47	0.10	-	-	-	43	
3' - <5'	0.22						0.34	0.36	0.10	-	-	-	43			
5' - 10'	0.20						0.26	0.28	0.10	-	-	-	39			
15'	0.27						0.33	0.34	0.10	-	-	-	38			
12	20'		0.36	0.44	0.45	0.10	-	-	-	38						
	25'		0.44	0.55	0.55	0.10	-	-	-	38						
	30'		0.52	0.66	0.67	0.10	-	-	-	38						
	6' x 6'		8	8	8	4	0.33' - <2'	0.30	0.54	0.50	0.20	0.22	0.22	0.30	-	
							2' - <3'	0.30	0.54	0.50	0.10	-	-	-	52	
3' - <5'		0.23					0.36	0.38	0.10	-	-	-	52			
5' - 10'		0.21					0.27	0.30	0.10	-	-	-	43			
15'		0.29					0.35	0.37	0.10	-	-	-	39			
12		20'	0.38	0.47	0.48	0.10	-	-	-	39						
		25'	0.47	0.59	0.60	0.10	-	-	-	38						
		30'	0.55	0.70	0.71	0.10	-	-	-	38						

12/17/2015 11:13:31 AM

**TABLE 3 - STANDARD PRECAST BOX CULVERT DESIGNS (2" COVER) - 7' SPANS**

SPAN x RISE (S) (R) (Ft.)	SLAB / WALL THICKNESS				DESIGN EARTH COVER ABOVE TOP SLAB	REINFORCEMENT AREAS (sq. in./Ft.)								As1 EXT. LENGTH (M) (in.)	
	TOP (Tt) (in.)	BOT. (Tb) (in.)	SIDE (Tw) (in.)	HAUNCH (H) (in.)		As1	As2	As3	As4	As5	As7	As8	As9		
7' x 4'	8	8	8	4 to 12	0.33' - <2'	0.37	0.58	0.49	0.20	0.22	0.29	0.37	-		
					2' - <3'	0.37	0.58	0.49	0.10	-	-	-	43		
					3' - <5'	0.30	0.40	0.42	0.10	-	-	-	43		
					5' - 10'	0.26	0.30	0.33	0.10	-	-	-	43		
					15'	0.37	0.40	0.40	0.10	-	-	-	41		
					20'	0.49	0.53	0.53	0.10	-	-	-	41		
	7 to 12	8	8	8	7	25'	0.60	0.67	0.66	0.10	-	-	-	41	
		8.5	8.5	8	12	30'	0.68	0.79	0.78	0.10	-	-	-	41	
		7' x 5'	8	8	8	4 to 12	0.33' - <2'	0.36	0.60	0.53	0.20	0.23	0.28	0.36	-
							2' - <3'	0.36	0.60	0.53	0.10	-	-	-	47
3' - <5'	0.30						0.42	0.45	0.10	-	-	-	43		
5' - 10'	0.26						0.32	0.35	0.10	-	-	-	43		
15'	0.37						0.43	0.44	0.10	-	-	-	41		
20'	0.48						0.57	0.57	0.10	-	-	-	41		
7 to 12	8		8	8	7	25'	0.60	0.72	0.72	0.10	-	-	-	41	
	8.5		8.5	8	12	30'	0.67	0.84	0.84	0.10	-	-	-	41	
	7' x 6'		8	8	8	4 to 12	0.33' - <2'	0.36	0.63	0.56	0.20	0.24	0.27	0.36	-
							2' - <3'	0.36	0.63	0.56	0.10	-	-	-	59
3' - <5'		0.29					0.44	0.47	0.10	-	-	-	47		
5' - 10'		0.27					0.34	0.37	0.10	-	-	-	43		
15'		0.38					0.46	0.46	0.10	-	-	-	41		
20'		0.49					0.60	0.61	0.10	-	-	-	41		
7 to 12		8	8	8	7	25'	0.61	0.76	0.76	0.10	-	-	-	41	
		8.5	8.5	8	12	30'	0.69	0.89	0.89	0.10	-	-	-	41	
		7' x 7'	8	8	8	4 to 12	0.33' - <2'	0.36	0.65	0.58	0.20	0.25	0.27	0.36	-
							2' - <3'	0.36	0.65	0.58	0.10	-	-	-	59
3' - <5'	0.30						0.46	0.50	0.10	-	-	-	59		
5' - 10'	0.30						0.35	0.50	0.10	-	-	-	47		
15'	0.41						0.48	0.50	0.10	-	-	-	43		
20'	0.53						0.64	0.65	0.10	-	-	-	43		
7 to 12	8		8	8	7	25'	0.65	0.80	0.81	0.10	-	-	-	43	
	8.5		9	8	12	30'	0.72	0.92	0.91	0.10	-	-	-	41	

See General Note 5

**TABLE 4 - STANDARD PRECAST BOX CULVERT DESIGNS (2" COVER) - 8' SPANS**

SPAN x RISE (S) (R) (Ft.)	SLAB / WALL THICKNESS				DESIGN EARTH COVER ABOVE TOP SLAB	REINFORCEMENT AREAS (sq. in./Ft.)								As1 EXT. LENGTH (M) (in.)	
	TOP (Tt) (in.)	BOT. (Tb) (in.)	SIDE (Tw) (in.)	HAUNCH (H) (in.)		As1	As2	As3	As4	As5	As7	As8	As9		
8' x 4'	8	8	8	4 to 12	0.33' - <2'	0.40	0.60	0.52	0.20	0.22	0.28	0.39	-		
					2' - <3'	0.45	0.66	0.54	0.10	-	-	-	50		
					3' - <5'	0.39	0.48	0.50	0.10	-	-	-	50		
					5' - 10'	0.34	0.38	0.40	0.10	-	-	-	45		
					15'	0.49	0.51	0.50	0.10	-	-	-	41		
					20'	0.65	0.68	0.66	0.10	-	-	-	41		
	8 to 12	8.5	8.5	8	8	25'	0.76	0.83	0.80	0.10	-	-	-	41	
		9.5	9.5	8	12	30'	0.79	0.94	0.92	0.10	-	-	-	41	
		8' x 5'	8	8	8	4 to 12	0.33' - <2'	0.38	0.65	0.59	0.20	0.22	0.30	0.37	-
							2' - <3'	0.43	0.69	0.58	0.10	-	-	-	50
3' - <5'	0.37						0.51	0.53	0.10	-	-	-	45		
5' - 10'	0.33						0.41	0.42	0.10	-	-	-	45		
15'	0.48						0.54	0.53	0.10	-	-	-	41		
20'	0.63						0.73	0.70	0.10	-	-	-	41		
8 to 12	8.5		8.5	8	8	25'	0.74	0.88	0.86	0.10	-	-	-	41	
	9.5		9.5	8	12	30'	0.77	1.00	0.98	0.10	-	-	-	41	
	8' x 6'		8	8	8	4 to 12	0.33' - <2'	0.32	0.65	0.58	0.20	0.23	0.25	0.31	-
							2' - <3'	0.42	0.71	0.61	0.10	-	-	-	50
3' - <5'		0.37					0.54	0.56	0.10	-	-	-	50		
5' - 10'		0.34					0.43	0.45	0.10	-	-	-	45		
15'		0.49					0.57	0.57	0.10	-	-	-	41		
20'		0.64					0.77	0.76	0.10	-	-	-	41		
8 to 12		8.5	8.5	8	8	25'	0.74	0.94	0.92	0.10	-	-	-	41	
		9.5	9.5	8	12	30'	0.78	1.05	1.04	0.10	-	-	-	41	
		8' x 7'	8	8	8	4 to 12	0.33' - <2'	0.31	0.67	0.60	0.20	0.24	0.24	0.31	-
							2' - <3'	0.42	0.74	0.64	0.10	-	-	-	55
3' - <5'	0.37						0.56	0.59	0.10	-	-	-	55		
5' - 10'	0.36						0.45	0.47	0.10	-	-	-	50		
15'	0.51						0.61	0.61	0.10	-	-	-	45		
20'	0.66						0.81	0.80	0.10	-	-	-	41		
8 to 12	8.5		8.5	8	8	25'	0.78	0.98	0.97	0.10	-	-	-	41	
	9.5		9.5	8	12	30'	0.84	1.10	1.09	0.10	-	-	-	41	
	8' x 8'		8	8	8	4 to 12	0.33' - <2'	0.32	0.68	0.62	0.20	0.24	0.25	0.32	-
							2' - <3'	0.43	0.76	0.67	0.14	-	-	-	65
3' - <5'		0.38					0.58	0.61	0.14	-	-	-	65		
5' - 10'		0.39					0.46	0.50	0.13	-	-	-	55		
15'		0.55					0.64	0.65	0.10	-	-	-	45		
20'		0.71					0.86	0.85	0.10	-	-	-	45		
8 to 12		8.5	8.5	8	8	25'	0.84	1.03	1.02	0.10	-	-	-	41	
		9.5	9.5	8	12	30'	0.93	1.15	1.15	0.10	-	-	-	41	

See General Note 5

**NOTES:**

1. See Sheet 1 for Reinforcing Details and dimension locations.
2. See Sheet 2 for General Notes.
3. See Sheet 14 for Welded Wire Reinforcement Bending Diagram.

LAST REVISION  
07/01/13

REVISION

DESCRIPTION:



FY 2016-17  
DESIGN STANDARDS

STANDARD PRECAST CONCRETE BOX CULVERTS

INDEX NO.  
292

SHEET NO.  
4 of 14

TABLE 5 - STANDARD PRECAST BOX CULVERT DESIGNS (2" COVER) - 9' SPANS

SPAN x RISE (S) (R) (Ft.)	SLAB / WALL THICKNESS				DESIGN EARTH COVER ABOVE TOP SLAB	REINFORCEMENT AREAS (sq. in./Ft.)								As1 EXT. LENGTH (M) (in.)
	TOP (Tt) (in.)	BOT. (Tb) (in.)	SIDE (Tw) (in.)	HAUNCH (H) (in.)		As1	As2	As3	As4	As5	As7	As8	As9	
9' x 5'	9.5	9.5	9	4	0.33' - <2'	0.41	0.62	0.53	0.22	0.23	0.34	0.38	-	
					2' - <3'	0.44	0.65	0.54	0.11	-	-	-	54	
	9	9	9	to	3' - <5'	0.39	0.53	0.51	0.11	-	-	-	49	
					5' - 10'	0.35	0.42	0.44	0.11	-	-	-	49	
	12	9.5	9.5	9	8 to	15'	0.50	0.56	0.55	0.11	-	-	-	44
						20'	0.65	0.75	0.73	0.11	-	-	-	44
10.5	11	9	12	12	25'	0.77	0.92	0.90	0.11	-	-	-	44	
30'	0.81	1.05	1.02	0.11	-	-	-	-	44					
9' x 6'	9.5	9.5	9	4	0.33' - <2'	0.38	0.64	0.56	0.23	0.23	0.33	0.37	-	
					2' - <3'	0.43	0.67	0.57	0.11	-	-	-	54	
	9	9	9	to	3' - <5'	0.37	0.55	0.54	0.11	-	-	-	49	
					5' - 10'	0.35	0.45	0.47	0.11	-	-	-	49	
	12	9.5	9.5	9	8 to	15'	0.49	0.60	0.59	0.11	-	-	-	44
						20'	0.65	0.80	0.78	0.11	-	-	-	44
10.5	11	9	12	12	25'	0.76	0.98	0.95	0.11	-	-	-	44	
30'	0.80	1.10	1.08	0.11	-	-	-	-	44					
9' x 7'	9.5	9.5	9	4	0.33' - <2'	0.37	0.67	0.59	0.22	0.23	0.32	0.37	-	
					2' - <3'	0.42	0.69	0.60	0.11	-	-	-	59	
	9	9	9	to	3' - <5'	0.37	0.58	0.56	0.11	-	-	-	54	
					5' - 10'	0.36	0.47	0.49	0.11	-	-	-	49	
	12	9.5	9.5	9	8 to	15'	0.50	0.63	0.63	0.11	-	-	-	44
						20'	0.66	0.84	0.80	0.11	-	-	-	44
10.5	11	9	12	12	25'	0.77	1.02	1.00	0.11	-	-	-	44	
30'	0.81	1.15	1.13	0.11	-	-	-	-	44					
9' x 8'	9.5	9.5	9	4	0.33' - <2'	0.37	0.68	0.61	0.22	0.23	0.31	0.37	-	
					2' - <3'	0.42	0.71	0.62	0.11	-	-	-	59	
	9	9	9	to	3' - <5'	0.37	0.60	0.59	0.11	-	-	-	59	
					5' - 10'	0.38	0.49	0.51	0.11	-	-	-	54	
	12	9.5	9.5	9	8 to	15'	0.53	0.66	0.66	0.11	-	-	-	44
						20'	0.68	0.88	0.87	0.11	-	-	-	44
10.5	11	9	12	12	25'	0.81	1.07	1.05	0.11	-	-	-	44	
30'	0.86	1.20	1.18	0.11	-	-	-	-	44					
9' x 9'	9.5	9.5	9	4	0.33' - <2'	0.38	0.70	0.63	0.22	0.23	0.32	0.38	-	
					2' - <3'	0.43	0.73	0.65	0.15	-	-	-	72	
	9	9	9	to	3' - <5'	0.38	0.62	0.61	0.15	-	-	-	72	
					5' - 10'	0.41	0.50	0.53	0.14	-	-	-	59	
	12	9.5	9.5	9	8 to	15'	0.57	0.69	0.70	0.12	-	-	-	49
						20'	0.73	0.92	0.91	0.11	-	-	-	49
10.5	11	9	12	12	25'	0.83	1.11	1.09	0.11	-	-	-	44	
30'	0.93	1.25	1.23	0.11	-	-	-	-	44					

See General Note 5

TABLE 6 - STANDARD PRECAST BOX CULVERT DESIGNS (2" COVER) - 10' SPANS

SPAN x RISE (S) (R) (Ft.)	SLAB / WALL THICKNESS				DESIGN EARTH COVER ABOVE TOP SLAB	REINFORCEMENT AREAS (sq. in./Ft.)								As1 EXT. LENGTH (M) (in.)
	TOP (Tt) (in.)	BOT. (Tb) (in.)	SIDE (Tw) (in.)	HAUNCH (H) (in.)		As1	As2	As3	As4	As5	As7	As8	As9	
10' x 5'	10	10	10	4	0.33' - <2'	0.46	0.62	0.52	0.24	0.24	0.41	0.45	-	
					2' - <3'	0.46	0.62	0.52	0.12	-	-	-	58	
	to	10	10	10	to	3' - <5'	0.42	0.54	0.50	0.12	-	-	-	53
						5' - 10'	0.38	0.46	0.49	0.12	-	-	-	52
	12	9.5	9.5	9	8 to	15'	0.52	0.59	0.58	0.12	-	-	-	47
						20'	0.69	0.78	0.76	0.12	-	-	-	47
10.5	10.5	10	8 to	25'	0.81	0.97	0.93	0.12	-	-	-	47		
11.5	12	10	12	30'	0.87	1.11	1.11	0.12	-	-	-	47		
10' x 6'	10	10	10	4	0.33' - <2'	0.44	0.64	0.54	0.24	0.24	0.39	0.44	-	
					2' - <3'	0.44	0.64	0.54	0.12	-	-	-	58	
	to	10	10	10	to	3' - <5'	0.39	0.57	0.52	0.12	-	-	-	52
						5' - 10'	0.37	0.48	0.52	0.12	-	-	-	52
	12	9.5	9.5	9	8 to	15'	0.51	0.62	0.61	0.12	-	-	-	47
						20'	0.67	0.83	0.80	0.12	-	-	-	47
10.5	10.5	10	8 to	25'	0.79	1.02	0.99	0.12	-	-	-	47		
11.5	12	10	12	30'	0.85	1.17	1.14	0.12	-	-	-	47		
10' x 7'	10	10	10	4	0.33' - <2'	0.43	0.66	0.57	0.24	0.24	0.38	0.43	-	
					2' - <3'	0.43	0.66	0.57	0.12	-	-	-	58	
	to	10	10	10	to	3' - <5'	0.38	0.59	0.55	0.12	-	-	-	58
						5' - 10'	0.37	0.50	0.54	0.12	-	-	-	52
	12	9.5	9.5	9	8 to	15'	0.52	0.66	0.65	0.12	-	-	-	47
						20'	0.67	0.87	0.85	0.12	-	-	-	47
10.5	10.5	10	8 to	25'	0.79	1.07	1.04	0.12	-	-	-	47		
11.5	12	10	12	30'	0.84	1.22	1.19	0.12	-	-	-	47		
10' x 8'	10	10	10	4	0.33' - <2'	0.43	0.68	0.60	0.24	0.24	0.38	0.43	-	
					2' - <3'	0.43	0.68	0.60	0.12	-	-	-	64	
	to	10	10	10	to	3' - <5'	0.38	0.62	0.57	0.12	-	-	-	58
						5' - 10'	0.38	0.52	0.57	0.12	-	-	-	52
	12	9.5	9.5	9	8 to	15'	0.53	0.69	0.68	0.12	-	-	-	47
						20'	0.68	0.91	0.89	0.12	-	-	-	47
10.5	10.5	10	8 to	25'	0.81	1.12	1.09	0.12	-	-	-	47		
11.5	12	10	12	30'	0.86	1.27	1.25	0.12	-	-	-	47		
10' x 9'	10	10	10	4	0.33' - <2'	0.43	0.70	0.62	0.24	0.24	0.38	0.43	-	
					2' - <3'	0.43	0.70	0.62	0.12	-	-	-	70	
	to	10	10	10	to	3' - <5'	0.39	0.64	0.60	0.12	-	-	-	64
						5' - 10'	0.40	0.54	0.59	0.12	-	-	-	58
	12	9.5	9.5	9	8 to	15'	0.56	0.72	0.72	0.12	-	-	-	52
						20'	0.71	0.95	0.94	0.12	-	-	-	47
10.5	11	10	8 to	25'	0.82	1.15	1.13	0.12	-	-	-	47		
11.5	12	10	12	30'	0.90	1.32	1.30	0.12	-	-	-	47		
10' x 10'	10	10	10	4	0.33' - <2'	0.44	0.71	0.64	0.24	0.24	0.38	0.44	-	
					2' - <3'	0.44	0.71	0.64	0.17	-	-	-	79	
	to	10	10	10	to	3' - <5'	0.40	0.65	0.62	0.16	-	-	-	70
						5' - 10'	0.44	0.56	0.61	0.15	-	-	-	64
	12	9.5	9.5	9	8 to	15'	0.60	0.75	0.76	0.12	-	-	-	52
						20'	0.76	0.99	0.99	0.12	-	-	-	52
10.5	11	10	8 to	25'	0.86	1.20	1.18	0.12	-	-	-	47		
11.5	12	10	12	30'	0.97	1.36	1.35	0.13	-	-	-	47		

See General Note 5

NOTES:

1. See Sheet 1 for Reinforcing Details and dimension locations.
2. See Sheet 2 for General Notes.
3. See Sheet 14 for WWR Bending Diagram.

12/17/2015 11:13:32 AM

**TABLE 7 - STANDARD PRECAST BOX CULVERT DESIGNS (2" COVER) - 11' SPANS**

SPAN x RISE (S) (R) (Ft.)	SLAB / WALL THICKNESS				DESIGN EARTH COVER ABOVE TOP SLAB	REINFORCEMENT AREAS (sq. in./Ft.)									As1 EXT. LENGTH (M) (in.)
	TOP (Tt) (in.)	BOT. (Tb) (in.)	SIDE (Tw) (in.)	HAUNCH (H) (in.)		As1	As2	As3	As4	As5	As7	As8	As9		
11' x 4'	11	11	11	4 to 12	0.33' - <2'	0.51	0.57	0.47	0.27	0.27	0.45	0.48	-		
					2' - <3'	0.51	0.57	0.47	0.14	-	-	-	62		
					3' - <5'	0.48	0.57	0.46	0.14	-	-	-	62		
					5' - 10'	0.47	0.50	0.50	0.14	-	-	-	55		
					15'	0.59	0.58	0.56	0.14	-	-	-	55		
					20'	0.77	0.77	0.74	0.14	-	-	-	55		
	11.5	11.5	11	8 to 12	25'	0.92	0.95	0.91	0.14	-	-	-	55		
	13	13	11		30'	0.94	1.09	1.06	0.14	-	-	-	55		
	11' x 6'	11	11		11	4 to 12	0.33' - <2'	0.45	0.62	0.52	0.27	0.27	0.41	0.45	-
							2' - <3'	0.45	0.62	0.52	0.14	-	-	-	62
3' - <5'				0.42			0.58	0.51	0.14	-	-	-	55		
5' - 10'				0.43			0.56	0.56	0.14	-	-	-	55		
15'				0.54			0.65	0.64	0.14	-	-	-	50		
20'				0.70			0.86	0.83	0.14	-	-	-	50		
11.5		11.5	11	8 to 12	25'	0.83	1.07	1.03	0.14	-	-	-	50		
13		13	11		30'	0.85	1.22	1.19	0.14	-	-	-	50		
11' x 8'		11	11		11	4 to 12	0.33' - <2'	0.42	0.67	0.57	0.27	0.27	0.39	0.43	-
							2' - <3'	0.43	0.67	0.57	0.14	-	-	-	62
	3' - <5'			0.39			0.63	0.56	0.14	-	-	-	62		
	5' - 10'			0.43			0.60	0.61	0.14	-	-	-	55		
	15'			0.54			0.72	0.71	0.14	-	-	-	50		
	20'			0.70			0.94	0.92	0.14	-	-	-	50		
	11.5	11.5	11	8 to 12	25'	0.82	1.16	1.13	0.14	-	-	-	50		
	13	13	11		30'	0.86	1.32	1.30	0.14	-	-	-	50		
	11' x 10'	11	11		11	4 to 12	0.33' - <2'	0.44	0.71	0.62	0.27	0.27	0.38	0.44	-
							2' - <3'	0.44	0.71	0.62	0.14	-	-	-	75
3' - <5'				0.41			0.67	0.61	0.14	-	-	-	69		
5' - 10'				0.47			0.64	0.66	0.14	-	-	-	62		
15'				0.59			0.78	0.78	0.14	-	-	-	55		
20'				0.75			1.03	1.01	0.14	-	-	-	50		
11.5		12	11	8 to 12	25'	0.85	1.24	1.22	0.14	-	-	-	50		
13		13.5	11		30'	0.91	1.40	1.39	0.14	-	-	-	50		
11' x 11'		11	11		11	4 to 12	0.33' - <2'	0.45	0.72	0.64	0.27	0.27	0.39	0.45	-
							2' - <3'	0.45	0.72	0.64	0.18	-	-	-	86
	3' - <5'			0.42			0.69	0.63	0.18	-	-	-	75		
	5' - 10'			0.51			0.66	0.69	0.16	-	-	-	69		
	15'			0.63			0.81	0.82	0.14	-	-	-	55		
	20'			0.80			1.07	1.06	0.14	-	-	-	55		
	11.5	12	11	8 to 12	25'	0.91	1.29	1.27	0.14	-	-	-	50		
	13	13.5	11		30'	0.99	1.44	1.44	0.14	-	-	-	50		

See General Note 5

**TABLE 8 - STANDARD PRECAST BOX CULVERT DESIGNS (2" COVER) - 12' SPANS**

SPAN x RISE (S) (R) (Ft.)	SLAB / WALL THICKNESS				DESIGN EARTH COVER ABOVE TOP SLAB	REINFORCEMENT AREAS (sq. in./Ft.)									As1 EXT. LENGTH (M) (in.)
	TOP (Tt) (in.)	BOT. (Tb) (in.)	SIDE (Tw) (in.)	HAUNCH (H) (in.)		As1	As2	As3	As4	As5	As7	As8	As9		
12' x 4'	12	12	12	4 to 12	0.33' - <2'	0.52	0.57	0.45	0.29	0.29	0.47	0.49	-		
					2' - <3'	0.52	0.57	0.45	0.15	-	-	-	73		
					3' - <5'	0.50	0.54	0.45	0.15	-	-	-	66		
					5' - 10'	0.50	0.52	0.52	0.15	-	-	-	66		
					15'	0.63	0.61	0.59	0.15	-	-	-	59		
					20'	0.82	0.81	0.77	0.15	-	-	-	59		
	12.5	12.5	12	8 to 12	25'	0.99	0.99	0.95	0.15	-	-	-	59		
	14	14	12		30'	1.03	1.15	1.11	0.15	-	-	-	59		
	12' x 6'	12	12		12	4 to 12	0.33' - <2'	0.47	0.62	0.51	0.29	0.29	0.42	0.46	-
							2' - <3'	0.47	0.62	0.51	0.15	-	-	-	66
3' - <5'				0.45			0.60	0.51	0.15	-	-	-	59		
5' - 10'				0.47			0.59	0.59	0.15	-	-	-	59		
15'				0.57			0.68	0.66	0.15	-	-	-	53		
20'				0.74			0.90	0.86	0.15	-	-	-	53		
12.5		12.5	12	8 to 12	25'	0.88	1.11	1.06	0.15	-	-	-	53		
14		14.5	12		30'	0.92	1.27	1.24	0.15	-	-	-	53		
12' x 8'		12	12		12	4 to 12	0.33' - <2'	0.44	0.67	0.56	0.29	0.29	0.40	0.44	-
							2' - <3'	0.44	0.67	0.56	0.15	-	-	-	66
	3' - <5'			0.41			0.64	0.56	0.15	-	-	-	59		
	5' - 10'			0.45			0.63	0.64	0.15	-	-	-	59		
	15'			0.56			0.75	0.73	0.15	-	-	-	53		
	20'			0.72			0.98	0.95	0.15	-	-	-	53		
	12.5	13	12	8 to 12	25'	0.85	1.20	1.16	0.15	-	-	-	53		
	14	14.5	12		30'	0.89	1.38	1.35	0.15	-	-	-	53		
	12' x 10'	12	12		12	4 to 12	0.33' - <2'	0.44	0.71	0.60	0.29	0.29	0.39	0.44	-
							2' - <3'	0.44	0.71	0.60	0.15	-	-	-	73
3' - <5'				0.42			0.68	0.60	0.15	-	-	-	66		
5' - 10'				0.47			0.67	0.69	0.15	-	-	-	59		
15'				0.59			0.81	0.81	0.15	-	-	-	53		
20'				0.75			1.06	1.04	0.15	-	-	-	53		
12.5		13	12	8 to 12	25'	0.87	1.30	1.26	0.15	-	-	-	53		
14		14.5	12		30'	0.92	1.47	1.45	0.15	-	-	-	53		
12' x 12'		12	12		12	4 to 12	0.33' - <2'	0.46	0.74	0.64	0.29	0.29	0.40	0.46	-
							2' - <3'	0.46	0.74	0.64	0.20	-	-	-	93
	3' - <5'			0.42			0.72	0.64	0.20	-	-	-	80		
	5' - 10'			0.54			0.71	0.74	0.18	-	-	-	73		
	15'			0.66			0.87	0.89	0.15	-	-	-	59		
	20'			0.83			1.14	1.13	0.15	-	-	-	59		
	12.5	13	12	8 to 12	25'	0.96	1.39	1.37	0.15	-	-	-	53		
	14	14.5	12.5		30'	1.05	1.56	1.56	0.15	-	-	-	53		

See General Note 5

**NOTES:**

1. See Sheet 1 for Reinforcing Details and dimension locations.
2. See Sheet 2 for General Notes.
3. See Sheet 14 for Welded Wire Reinforcement Bending Diagram.

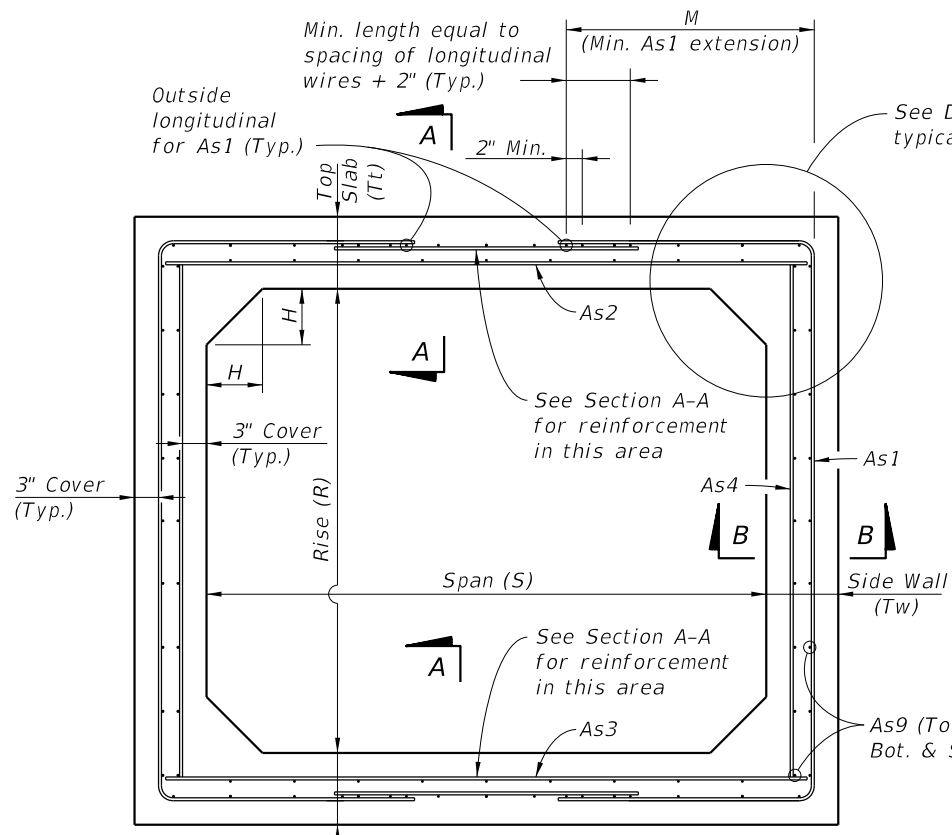

**TYPICAL BOX SECTION (TYPE 2)  
DESIGN EARTH COVER 2' OR GREATER  
(Option 1 Reinforcing Configuration Shown)**

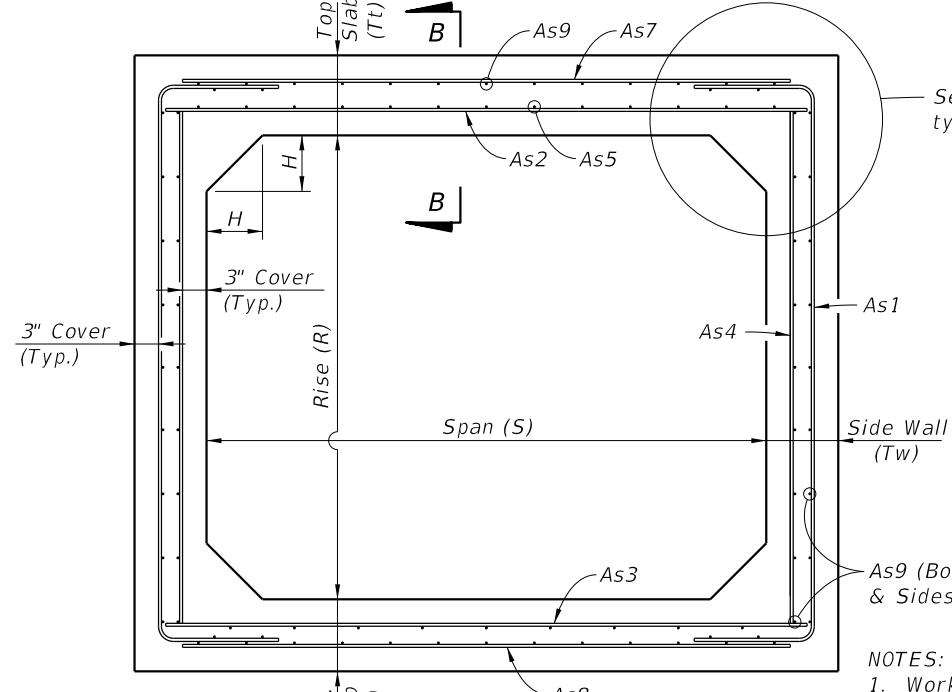

**TYPICAL BOX SECTION (TYPE 1)  
DESIGN EARTH COVER LESS THAN 2'  
(Option 1 Reinforcing Configuration Shown)**

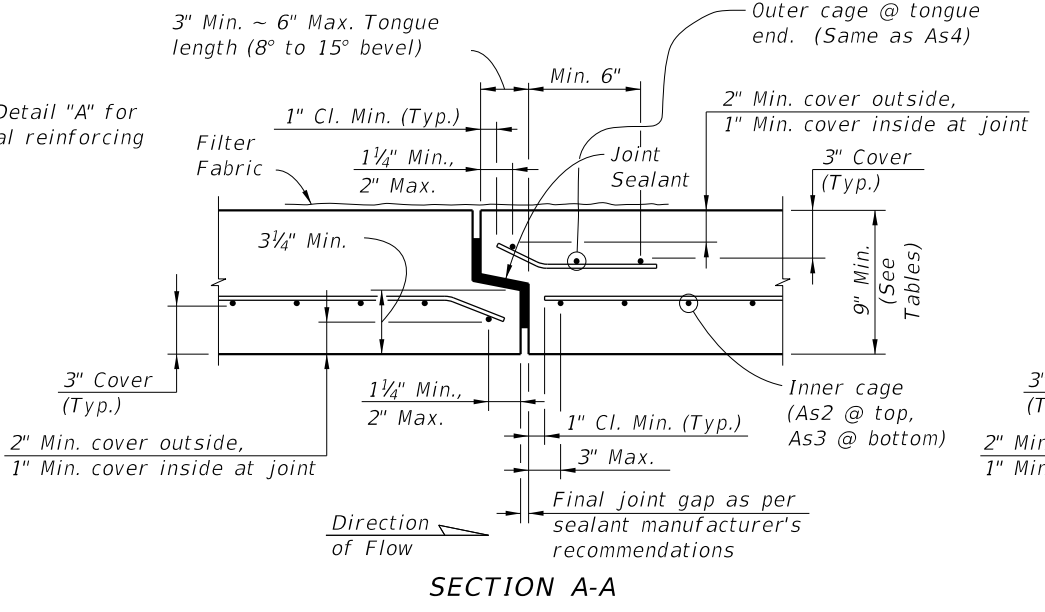

**SECTION A-A**

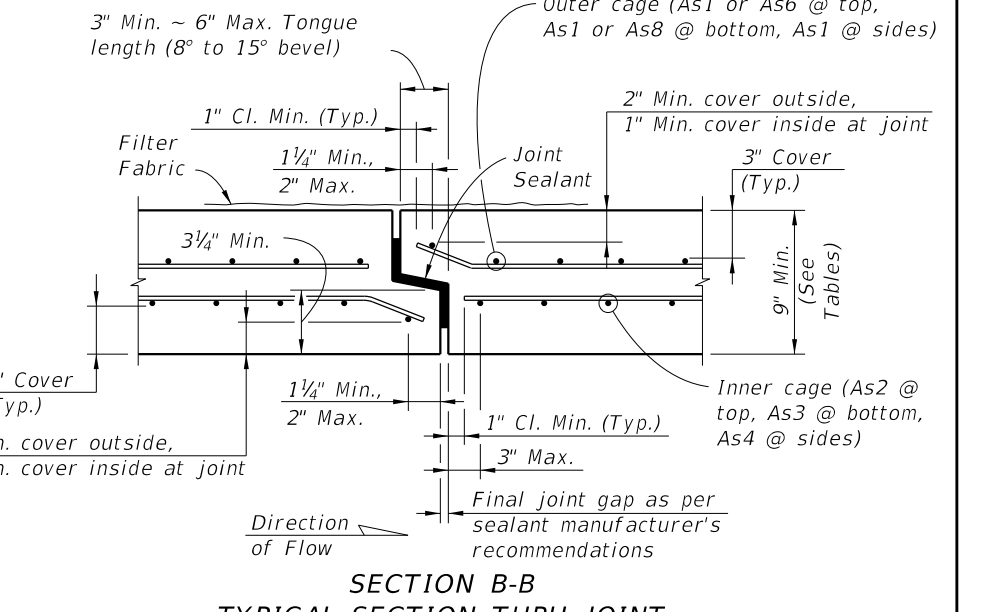

**SECTION B-B  
TYPICAL SECTION THRU JOINT**

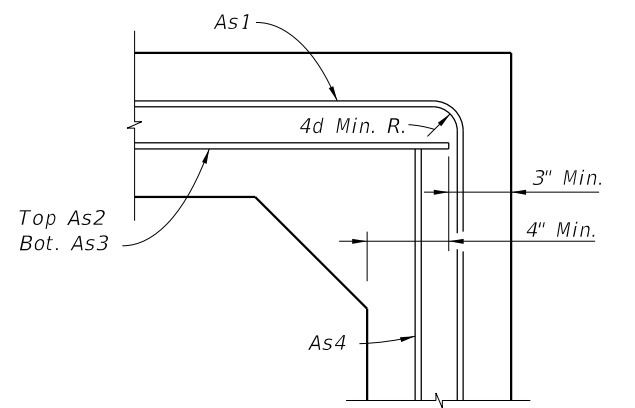

**DETAIL "A"  
(OPTION 1)**

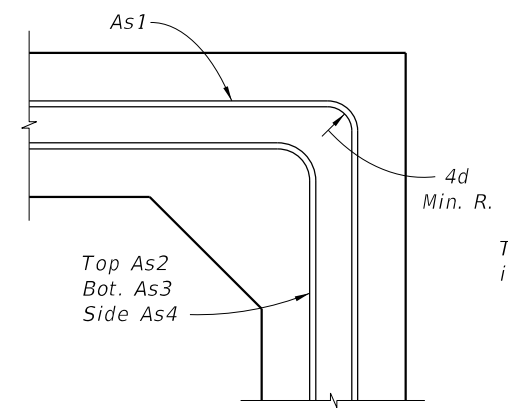

**DETAIL "A"  
(OPTION 2)**

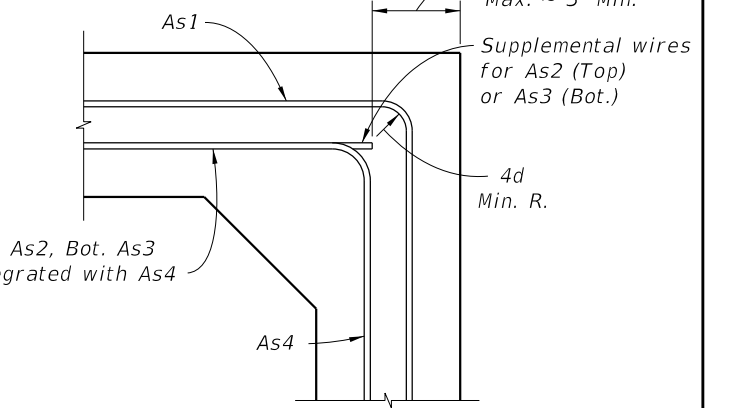

**DETAIL "A"  
(OPTION 3)**

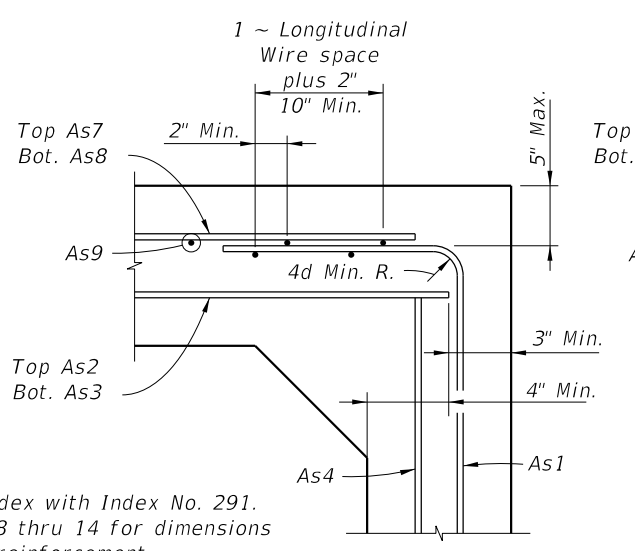

**DETAIL "B"  
(OPTION 1)**

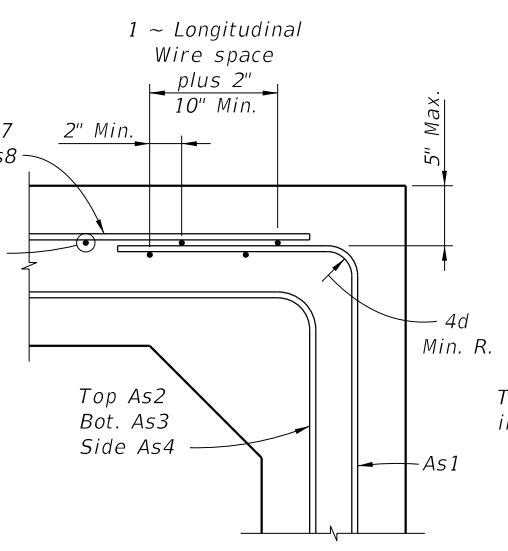

**DETAIL "B"  
(OPTION 2)**

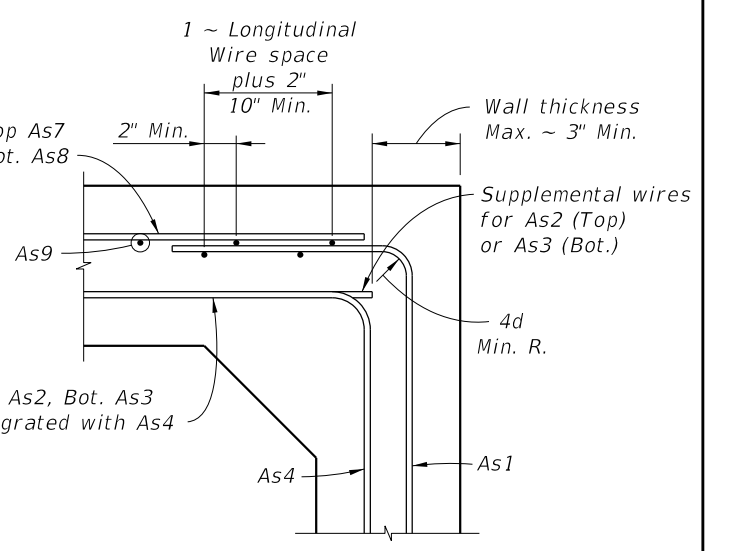

**DETAIL "B"  
(OPTION 3)**

**NOTES:**  
1. Work this Index with Index No. 291.  
2. See Sheets 8 thru 14 for dimensions and areas of reinforcement.

**STANDARD PRECAST BOX CULVERT WITH 3" CONCRETE COVER**

12/17/2015 11:13:33 AM

LAST REVISION 07/01/13	REVISION	DESCRIPTION:	 <b>FY 2016-17 DESIGN STANDARDS</b>	<b>STANDARD PRECAST CONCRETE BOX CULVERTS</b>	INDEX NO. <b>292</b>	SHEET NO. <b>7 of 14</b>
---------------------------	----------	--------------	--	---	-------------------------	-----------------------------

**TABLE 9A - STANDARD PRECAST BOX CULVERT DESIGNS (3" COVER) - 3' & 4' SPANS**

SPAN x RISE (S) (R) (Ft.)	SLAB / WALL THICKNESS				DESIGN EARTH COVER ABOVE TOP SLAB	REINFORCEMENT AREAS (sq. in./Ft.)								As1 EXT. LENGTH (M) (in.)					
	TOP (Tt) (in.)	BOT. (Tb) (in.)	SIDE (Tw) (in.)	HAUNCH (H) (in.)		As1	As2	As3	As4	As5	As7	As8	As9						
3' x 3'	9	9	9	4 to 8	0.33' - <2'	0.22	0.24	0.22	0.22	0.22	0.22	0.22	-	-					
					2' - <3'	0.11	0.23	0.22	0.11	-	-	-	-	-	31				
					3' - <5'	0.11	0.22	0.22	0.11	-	-	-	-	-	31				
					5' - 10'	0.11	0.22	0.22	0.11	-	-	-	-	-	31				
					15'	0.11	0.22	0.22	0.11	-	-	-	-	-	31				
					20'	0.13	0.22	0.22	0.11	-	-	-	-	-	31				
					25'	0.16	0.22	0.22	0.11	-	-	-	-	-	31				
					30'	0.19	0.24	0.25	0.11	-	-	-	-	-	31				
					35'	0.22	0.28	0.29	0.11	-	-	-	-	-	31				
					4' x 3'	9	9	9	4 to 8	0.33' - <2'	0.22	0.32	0.24	0.22	0.22	0.22	0.22	-	-
2' - <3'	0.17	0.31	0.24	0.11						-	-	-	-	-	38				
3' - <5'	0.13	0.22	0.22	0.11						-	-	-	-	-	38				
5' - 10'	0.13	0.22	0.22	0.11						-	-	-	-	-	38				
15'	0.17	0.22	0.22	0.11						-	-	-	-	-	38				
20'	0.23	0.26	0.27	0.11						-	-	-	-	-	38				
25'	0.28	0.32	0.34	0.11						-	-	-	-	-	38				
30'	0.33	0.39	0.40	0.11						-	-	-	-	-	38				
4' x 4'	9	9	9	4 to 8						0.33' - <2'	0.22	0.34	0.26	0.22	0.22	0.22	0.22	-	-
										2' - <3'	0.17	0.33	0.26	0.11	-	-	-	-	-
					3' - <5'	0.13	0.22	0.22	0.11	-	-	-	-	-	38				
					5' - 10'	0.14	0.22	0.22	0.11	-	-	-	-	-	38				
					15'	0.19	0.22	0.23	0.11	-	-	-	-	-	38				
					20'	0.24	0.28	0.30	0.11	-	-	-	-	-	38				
					25'	0.29	0.36	0.37	0.11	-	-	-	-	-	38				
					30'	0.34	0.43	0.45	0.11	-	-	-	-	-	38				

**TABLE 9B - STANDARD PRECAST BOX CULVERT DESIGNS (3" COVER) - 3' & 4' SPANS**

SPAN x RISE (S) (R) (Ft.)	SLAB / WALL THICKNESS				DESIGN EARTH COVER ABOVE TOP SLAB	REINFORCEMENT AREAS (sq. in./Ft.)								As1 EXT. LENGTH (M) (in.)					
	TOP (Tt) (in.)	BOT. (Tb) (in.)	SIDE (Tw) (in.)	HAUNCH (H) (in.)		As1	As2	As3	As4	As5	As7	As8	As9						
3' x 3'	10	10	10	4 to 8	0.33' - <2'	0.24	0.24	0.24	0.24	0.24	0.24	0.24	-	-					
					2' - <3'	0.12	0.24	0.24	0.24	-	-	-	-	-	31				
					3' - <5'	0.12	0.24	0.24	0.24	-	-	-	-	-	31				
					5' - 10'	0.12	0.24	0.24	0.24	-	-	-	-	-	31				
					15'	0.12	0.24	0.24	0.24	-	-	-	-	-	31				
					20'	0.12	0.24	0.24	0.24	-	-	-	-	-	31				
					25'	0.13	0.24	0.24	0.24	-	-	-	-	-	31				
					30'	0.15	0.24	0.24	0.12	-	-	-	-	-	31				
					35'	0.18	0.24	0.24	0.12	-	-	-	-	-	31				
					4' x 3'	10	10	10	4 to 8	0.33' - <2'	0.24	0.26	0.24	0.24	0.24	0.24	0.24	-	-
2' - <3'	0.14	0.26	0.24	0.12						-	-	-	-	-	38				
3' - <5'	0.12	0.24	0.24	0.12						-	-	-	-	-	38				
5' - 10'	0.12	0.24	0.24	0.12						-	-	-	-	-	38				
15'	0.14	0.24	0.24	0.12						-	-	-	-	-	38				
20'	0.18	0.24	0.24	0.12						-	-	-	-	-	38				
25'	0.22	0.26	0.27	0.12						-	-	-	-	-	38				
30'	0.26	0.31	0.32	0.12						-	-	-	-	-	38				
4' x 4'	10	10	10	4 to 8						0.33' - <2'	0.24	0.28	0.24	0.24	0.24	0.24	0.24	-	-
										2' - <3'	0.14	0.28	0.24	0.12	-	-	-	-	-
					3' - <5'	0.12	0.24	0.24	0.12	-	-	-	-	-	38				
					5' - 10'	0.12	0.24	0.24	0.12	-	-	-	-	-	38				
					15'	0.15	0.24	0.24	0.12	-	-	-	-	-	38				
					20'	0.19	0.24	0.24	0.12	-	-	-	-	-	38				
					25'	0.23	0.28	0.30	0.12	-	-	-	-	-	38				
					30'	0.27	0.34	0.35	0.12	-	-	-	-	-	38				

**NOTES:**

1. See Sheet 2 for General Notes.
2. See Sheet 7 for Reinforcing Details and dimension locations.
3. See Sheet 14 for WWR Bending Diagrams.

12/17/2015 11:13:34 AM



TABLE 10A - STANDARD PRECAST BOX CULVERT DESIGNS (3" COVER) - 5' & 6' SPANS

SPAN x RISE (S) (R) (Ft.)	SLAB / WALL THICKNESS				DESIGN EARTH COVER ABOVE TOP SLAB	REINFORCEMENT AREAS (sq. in./Ft.)								As1 EXT. LENGTH (M) (in.)
	TOP (Tt) (in.)	BOT. (Tb) (in.)	SIDE (Tw) (in.)	HAUNCH (H) (in.)		As1	As2	As3	As4	As5	As7	As8	As9	
5' x 3'	9	9	9	4	0.33' - <2'	0.27	0.39	0.37	0.22	0.22	0.22	0.27	-	
					2' - <3'	0.26	0.39	0.37	0.11	-	-	-	45	
					3' - <5'	0.19	0.24	0.25	0.11	-	-	-	36	
					5' - 10'	0.20	0.22	0.22	0.11	-	-	-	36	
					15'	0.28	0.28	0.30	0.11	-	-	-	35	
					20'	0.37	0.38	0.39	0.11	-	-	-	35	
					25'	0.45	0.48	0.49	0.11	-	-	-	35	
					30'	0.54	0.58	0.59	0.11	-	-	-	35	
					5' x 4'	9	9	9	4	0.33' - <2'	0.26	0.42	0.39	0.22
2' - <3'	0.26	0.42	0.39	0.11						-	-	-	45	
3' - <5'	0.19	0.26	0.27	0.11						-	-	-	45	
5' - 10'	0.20	0.22	0.23	0.11						-	-	-	36	
15'	0.27	0.31	0.33	0.11						-	-	-	35	
20'	0.36	0.42	0.43	0.11						-	-	-	35	
25'	0.44	0.52	0.54	0.11						-	-	-	35	
30'	0.53	0.63	0.65	0.11						-	-	-	35	
5' x 5'	9	9	9	4						0.33' - <2'	0.27	0.44	0.42	0.22
					2' - <3'	0.27	0.44	0.42	0.11	-	-	-	45	
					3' - <5'	0.20	0.27	0.28	0.11	-	-	-	45	
					5' - 10'	0.22	0.23	0.26	0.11	-	-	-	45	
					15'	0.30	0.34	0.36	0.11	-	-	-	36	
					20'	0.38	0.45	0.47	0.11	-	-	-	35	
					25'	0.47	0.56	0.59	0.11	-	-	-	35	
					30'	0.55	0.68	0.71	0.11	-	-	-	35	
					6' x 3'	9	9	9	4	0.33' - <2'	0.34	0.47	0.42	0.22
2' - <3'	0.34	0.47	0.42	0.11						-	-	-	43	
3' - <5'	0.27	0.31	0.32	0.11						-	-	-	39	
5' - 10'	0.29	0.26	0.28	0.11						-	-	-	39	
15'	0.42	0.39	0.40	0.11						-	-	-	38	
20'	0.55	0.52	0.53	0.11						-	-	-	38	
25'	0.68	0.66	0.67	0.11						-	-	-	38	
30'	0.82	0.81	0.82	0.11						-	-	-	38	
6' x 4'	9	9	9	4						0.33' - <2'	0.33	0.50	0.46	0.22
					2' - <3'	0.33	0.50	0.46	0.11	-	-	-	43	
					3' - <5'	0.27	0.33	0.35	0.11	-	-	-	39	
					5' - 10'	0.28	0.29	0.31	0.11	-	-	-	39	
					15'	0.40	0.43	0.45	0.11	-	-	-	38	
					20'	0.52	0.57	0.59	0.11	-	-	-	38	
					25'	0.65	0.73	0.74	0.11	-	-	-	38	
					30'	0.78	0.88	0.90	0.11	-	-	-	38	
					6' x 5'	9	9	9	4	0.33' - <2'	0.33	0.52	0.49	0.22
2' - <3'	0.33	0.52	0.49	0.11						-	-	-	43	
3' - <5'	0.27	0.35	0.37	0.11						-	-	-	43	
5' - 10'	0.29	0.31	0.34	0.11						-	-	-	39	
15'	0.41	0.46	0.49	0.11						-	-	-	38	
20'	0.53	0.62	0.64	0.11						-	-	-	38	
25'	0.66	0.78	0.80	0.11						-	-	-	38	
30'	0.78	0.95	0.97	0.11						-	-	-	38	
6' x 6'	9	9	9	4						0.33' - <2'	0.34	0.55	0.51	0.22
					2' - <3'	0.34	0.54	0.51	0.11	-	-	-	52	
					3' - <5'	0.29	0.37	0.39	0.11	-	-	-	52	
					5' - 10'	0.32	0.34	0.37	0.11	-	-	-	43	
					15'	0.44	0.50	0.53	0.11	-	-	-	39	
					20'	0.57	0.66	0.70	0.11	-	-	-	39	
					25'	0.70	0.84	0.87	0.11	-	-	-	38	
					30'	0.83	1.02	1.05	0.11	-	-	-	38	

See General Note 5

See General Note 5

TABLE 10B - STANDARD PRECAST BOX CULVERT DESIGNS (3" COVER) - 5' & 6' SPANS

SPAN x RISE (S) (R) (Ft.)	SLAB / WALL THICKNESS				DESIGN EARTH COVER ABOVE TOP SLAB	REINFORCEMENT AREAS (sq. in./Ft.)								As1 EXT. LENGTH (M) (in.)
	TOP (Tt) (in.)	BOT. (Tb) (in.)	SIDE (Tw) (in.)	HAUNCH (H) (in.)		As1	As2	As3	As4	As5	As7	As8	As9	
5' x 3'	10	10	10	4	0.33' - <2'	0.24	0.33	0.32	0.24	0.24	0.24	0.24	-	
					2' - <3'	0.22	0.33	0.32	0.12	-	-	-	45	
					3' - <5'	0.16	0.24	0.24	0.12	-	-	-	36	
					5' - 10'	0.16	0.24	0.24	0.12	-	-	-	36	
					15'	0.23	0.24	0.24	0.12	-	-	-	35	
					20'	0.29	0.30	0.31	0.12	-	-	-	35	
					25'	0.36	0.38	0.39	0.12	-	-	-	35	
					30'	0.43	0.46	0.47	0.12	-	-	-	35	
					5' x 4'	10	10	10	4	0.33' - <2'	0.24	0.35	0.34	0.24
2' - <3'	0.22	0.35	0.34	0.12						-	-	-	45	
3' - <5'	0.15	0.24	0.24	0.12						-	-	-	45	
5' - 10'	0.16	0.24	0.24	0.12						-	-	-	36	
15'	0.22	0.25	0.27	0.12						-	-	-	35	
20'	0.29	0.33	0.34	0.12						-	-	-	35	
25'	0.36	0.41	0.43	0.12						-	-	-	35	
30'	0.42	0.50	0.51	0.12						-	-	-	35	
5' x 5'	10	10	10	4						0.33' - <2'	0.24	0.37	0.36	0.24
					2' - <3'	0.21	0.37	0.36	0.12	-	-	-	45	
					3' - <5'	0.16	0.24	0.25	0.12	-	-	-	45	
					5' - 10'	0.17	0.24	0.24	0.12	-	-	-	45	
					15'	0.24	0.27	0.29	0.12	-	-	-	36	
					20'	0.30	0.36	0.38	0.12	-	-	-	35	
					25'	0.37	0.44	0.47	0.12	-	-	-	35	
					30'	0.44	0.53	0.56	0.12	-	-	-	35	
					6' x 3'	10	10	10	4	0.33' - <2'	0.28	0.40	0.36	0.24
2' - <3'	0.28	0.40	0.36	0.12						-	-	-	43	
3' - <5'	0.22	0.26	0.28	0.12						-	-	-	39	
5' - 10'	0.24	0.24	0.24	0.12						-	-	-	39	
15'	0.34	0.31	0.32	0.12						-	-	-	38	
20'	0.44	0.41	0.42	0.12						-	-	-	38	
25'	0.54	0.52	0.53	0.12						-	-	-	38	
30'	0.64	0.63	0.64	0.12						-	-	-	38	
6' x 4'	10	10	10	4						0.33' - <2'	0.27	0.42	0.39	0.24
					2' - <3'	0.27	0.42	0.39	0.12	-	-	-	43	
					3' - <5'	0.21	0.28	0.30	0.12	-	-	-	39	
					5' - 10'	0.23	0.24	0.25	0.12	-	-	-	39	
					15'	0.32	0.34	0.35	0.12	-	-	-	38	
					20'	0.42	0.45	0.47	0.12	-	-	-	38	
					25'	0.51	0.56	0.58	0.12	-	-	-	38	
					30'	0.61	0.68	0.70	0.12	-	-	-	38	
					6' x 5'	10	10	10	4	0.33' - <2'	0.26	0.44	0.42	0.24
2' - <3'	0.26	0.44	0.42	0.12						-	-	-	43	
3' - <5'	0.22	0.30	0.33	0.12						-	-	-	43	
5' - 10'	0.24	0.25	0.27	0.12						-	-	-	39	
15'	0.33	0.36	0.39	0.12						-	-	-	38	
20'	0.42	0.48	0.51	0.12						-	-	-	38	
25'	0.52	0.61	0.63	0.12						-	-	-	38	
30'	0.61	0.74	0.76	0.12						-	-	-	38	
6' x 6'	10	10	10	4						0.33' - <2'	0.27	0.46	0.44	0.24
					2' - <3'	0.27	0.46	0.44	0.12	-	-	-	52	
					3' - <5'	0.23	0.31	0.34	0.12	-	-	-	52	
					5' - 10'	0.25	0.27	0.30	0.12	-	-	-	43	
					15'	0.35	0.39	0.42	0.12	-	-	-	39	
					20'	0.45	0.52	0.55	0.12	-	-	-	39	
					25'	0.54	0.65	0.68	0.12	-	-	-	38	
					30'	0.64	0.78	0.81	0.12	-	-	-	38	

See General Note 5

See General Note 5

12/17/2015 11:13:34 AM

TABLE 11A - STANDARD PRECAST BOX CULVERT DESIGNS (3" COVER) - 7' SPANS

SPAN x RISE (S) (R) (Ft.)	SLAB / WALL THICKNESS				DESIGN EARTH COVER ABOVE TOP SLAB	REINFORCEMENT AREAS (sq. in./Ft.)								As1 EXT. LENGTH (M) (in.)			
	TOP (Tt) (in.)	BOT. (Tb) (in.)	SIDE (Tw) (in.)	HAUNCH (H) (in.)		As1	As2	As3	As4	As5	As7	As8	As9				
7' x 4'	9	9	9	4 to 12	0.33' - <2'	0.42	0.58	0.52	0.22	0.22	0.31	0.42	-				
					2' - <3'	0.42	0.58	0.51	0.11	-	-	-	43				
					3' - <5'	0.36	0.41	0.44	0.11	-	-	-	43				
					5' - 10'	0.39	0.40	0.39	0.11	-	-	-	43				
					15'	0.56	0.56	0.58	0.11	-	-	-	41				
	9	9.5	9	7 to 12	20'	0.74	0.76	0.77	0.11	-	-	-	41				
					25'	0.92	0.97	0.97	0.11	-	-	-	41				
					30'	1.09	1.18	1.10	0.11	-	-	-	41				
					7' x 5'	9	9	4 to 12	0.33' - <2'	0.41	0.61	0.55	0.22	0.23	0.30	0.41	-
									2' - <3'	0.41	0.61	0.55	0.11	-	-	-	47
3' - <5'	0.37	0.43	0.47	0.11					-	-	-	43					
5' - 10'	0.39	0.41	0.43	0.11					-	-	-	43					
15'	0.56	0.61	0.63	0.11					-	-	-	41					
9	9.5	9	7 to 12	20'	0.73	0.82	0.83	0.11	-	-	-	41					
				25'	0.90	1.04	1.06	0.11	-	-	-	41					
				30'	1.06	1.26	1.19	0.11	-	-	-	41					
				7' x 6'	9	9	4 to 12	0.33' - <2'	0.42	0.63	0.58	0.22	0.24	0.30	0.42	-	
								2' - <3'	0.42	0.63	0.58	0.11	-	-	-	59	
3' - <5'	0.38	0.45	0.50					0.11	-	-	-	47					
5' - 10'	0.41	0.44	0.47					0.11	-	-	-	43					
15'	0.57	0.65	0.68					0.11	-	-	-	41					
9	9.5	9	7 to 12	20'	0.75	0.87	0.90	0.11	-	-	-	41					
				25'	0.93	1.11	1.13	0.11	-	-	-	41					
				30'	1.07	1.35	1.27	0.11	-	-	-	41					
				7' x 7'	9	9	4 to 12	0.33' - <2'	0.44	0.66	0.61	0.22	0.25	0.31	0.44	-	
								2' - <3'	0.44	0.65	0.61	0.11	-	-	-	59	
3' - <5'	0.41	0.47	0.52					0.11	-	-	-	59					
5' - 10'	0.44	0.47	0.52					0.11	-	-	-	47					
15'	0.62	0.69	0.74					0.11	-	-	-	43					
9	9.5	9	7 to 12	20'	0.80	0.93	0.97	0.11	-	-	-	43					
				25'	0.99	1.18	1.22	0.11	-	-	-	43					
				30'	1.12	1.43	1.36	0.11	-	-	-	41					

See General Note 5

TABLE 11B - STANDARD PRECAST BOX CULVERT DESIGNS (3" COVER) - 7' SPANS

SPAN x RISE (S) (R) (Ft.)	SLAB / WALL THICKNESS				DESIGN EARTH COVER ABOVE TOP SLAB	REINFORCEMENT AREAS (sq. in./Ft.)								As1 EXT. LENGTH (M) (in.)			
	TOP (Tt) (in.)	BOT. (Tb) (in.)	SIDE (Tw) (in.)	HAUNCH (H) (in.)		As1	As2	As3	As4	As5	As7	As8	As9				
7' x 4'	10	10	10	4 to 12	0.33' - <2'	0.33	0.49	0.44	0.24	0.24	0.24	0.33	-				
					2' - <3'	0.33	0.49	0.44	0.12	-	-	-	43				
					3' - <5'	0.29	0.35	0.38	0.12	-	-	-	43				
					5' - 10'	0.31	0.30	0.31	0.12	-	-	-	43				
					15'	0.44	0.44	0.45	0.12	-	-	-	41				
	10	10	10	7 to 12	20'	0.58	0.59	0.60	0.12	-	-	-	41				
					25'	0.71	0.74	0.75	0.12	-	-	-	41				
					30'	0.85	0.91	0.91	0.12	-	-	-	41				
					7' x 5'	10	10	4 to 12	0.33' - <2'	0.32	0.51	0.47	0.24	0.24	0.24	0.32	-
									2' - <3'	0.32	0.51	0.47	0.12	-	-	-	47
3' - <5'	0.29	0.37	0.41	0.12					-	-	-	43					
5' - 10'	0.31	0.32	0.35	0.12					-	-	-	43					
15'	0.44	0.47	0.50	0.12					-	-	-	41					
10	10	10	7 to 12	20'	0.57	0.63	0.65	0.12	-	-	-	41					
				25'	0.70	0.80	0.82	0.12	-	-	-	41					
				30'	0.84	0.97	0.99	0.12	-	-	-	41					
				7' x 6'	10	10	4 to 12	0.33' - <2'	0.33	0.53	0.50	0.24	0.24	0.24	0.33	-	
								2' - <3'	0.33	0.53	0.50	0.12	-	-	-	59	
3' - <5'	0.30	0.38	0.43					0.12	-	-	-	47					
5' - 10'	0.33	0.35	0.38					0.12	-	-	-	43					
15'	0.45	0.51	0.54					0.12	-	-	-	41					
10	10	10	7 to 12	20'	0.58	0.68	0.70	0.12	-	-	-	41					
				25'	0.72	0.85	0.88	0.12	-	-	-	41					
				30'	0.85	1.04	1.06	0.12	-	-	-	41					
				7' x 7'	10	10	4 to 12	0.33' - <2'	0.35	0.55	0.52	0.24	0.24	0.24	0.35	-	
								2' - <3'	0.35	0.55	0.52	0.12	-	-	-	59	
3' - <5'	0.32	0.40	0.46					0.12	-	-	-	59					
5' - 10'	0.35	0.37	0.41					0.12	-	-	-	47					
15'	0.48	0.54	0.58					0.12	-	-	-	43					
10	10	10	7 to 12	20'	0.62	0.72	0.76	0.12	-	-	-	43					
				25'	0.76	0.90	0.94	0.12	-	-	-	43					
				30'	0.90	1.10	1.13	0.12	-	-	-	41					

See General Note 5

- NOTES:  
 1. See Sheet 2 for General Notes.  
 2. See Sheet 7 for Reinforcing Details and dimension locations.  
 3. See Sheet 14 for WWR Bending Diagrams.

12/17/2015 11:13:35 AM

12/17/2015 11:13:36 AM

TABLE 12A - STANDARD PRECAST BOX CULVERT DESIGNS (3" COVER) - 8' SPANS

Table with columns: SPAN x RISE (S) (R), SLAB / WALL THICKNESS (TOP, BOT., SIDE, HAUNCH), DESIGN EARTH COVER ABOVE TOP SLAB, REINFORCEMENT AREAS (As1-As9), As1 EXT. LENGTH (M) (in.).

TABLE 12B - STANDARD PRECAST BOX CULVERT DESIGNS (3" COVER) - 8' SPANS

Table with columns: SPAN x RISE (S) (R), SLAB / WALL THICKNESS (TOP, BOT., SIDE, HAUNCH), DESIGN EARTH COVER ABOVE TOP SLAB, REINFORCEMENT AREAS (As1-As9), As1 EXT. LENGTH (M) (in.).

See General Note 5

See General Note 5

- NOTES: 1. See Sheet 2 for General Notes. 2. See Sheet 7 for Reinforcing Details and dimension locations. 3. See Sheet 14 for WWR Bending Diagrams.

LAST REVISION 07/01/13 DESCRIPTION:



FY 2016-17 STANDARD PRECAST CONCRETE BOX CULVERTS

INDEX NO. 292 SHEET NO. 11 of 14

TABLE 13A - STANDARD PRECAST BOX CULVERT DESIGNS (3" COVER) - 9' SPANS

SPAN x RISE (S) (R) (Ft.)	SLAB / WALL THICKNESS				DESIGN EARTH COVER ABOVE TOP SLAB	REINFORCEMENT AREAS (sq. in./Ft.)									As1 EXT. LENGTH (M) (in.)	
	TOP (Tt) (in.)	BOT. (Tb) (in.)	SIDE (Tw) (in.)	HAUNCH (H) (in.)		As1	As2	As3	As4	As5	As7	As8	As9			
9' x 5'	9	9	9	4 to 12	0.33' - <2'	0.62	0.78	0.65	0.22	0.26	0.52	0.61	-			
					2' - <3'	0.62	0.78	0.65	0.11	-	-	-				
					3' - <5'	0.58	0.63	0.61	0.11	-	-	-				
					5' - 10'	0.65	0.63	0.64	0.11	-	-	-				
					15'	0.95	0.96	0.95	0.11	-	-	-				
					20'	1.26	1.32	1.28	0.11	-	-	-				
	9 to 10 to 11	9 9 10.5 9 11.5 9	8 to 12	25'	1.39	1.41	1.32	0.11	-	-	-					
				30'	1.46	1.50	1.42	0.11	-	-	-					
				9' x 6'	9	9	4 to 12	0.33' - <2'	0.60	0.81	0.69	0.22	0.27	0.51	0.60	-
								2' - <3'	0.60	0.81	0.69	0.11	-	-	-	
								3' - <5'	0.56	0.66	0.65	0.11	-	-	-	
								5' - 10'	0.65	0.68	0.69	0.11	-	-	-	
15'	0.94	1.03	1.02					0.11	-	-	-					
20'	1.25	1.40	1.38					0.11	-	-	-					
9 to 10 to 11	9 9 10.5 9 11.5 9	8 to 12	25'		1.37	1.49	1.40	0.11	-	-	-					
			30'		1.44	1.58	1.50	0.11	-	-	-					
			9' x 7'		9	9	4 to 12	0.33' - <2'	0.61	0.84	0.72	0.22	0.28	0.51	0.61	-
								2' - <3'	0.61	0.83	0.72	0.11	-	-	-	
								3' - <5'	0.58	0.69	0.68	0.11	-	-	-	
								5' - 10'	0.67	0.73	0.75	0.11	-	-	-	
15'	0.96	1.09		1.10				0.11	-	-	-					
20'	1.27	1.49		1.47				0.11	-	-	-					
9 to 10 to 11	9 9 10.5 9 11.5 9	8 to 12		25'	1.38	1.57	1.48	0.11	-	-	-					
				30'	1.49	1.70	1.58	0.11	-	-	-					
				9' x 8'	9	9	4 to 12	0.33' - <2'	0.60	0.85	0.73	0.22	0.29	0.52	0.53	-
								2' - <3'	0.64	0.86	0.76	0.12	-	-	-	
								3' - <5'	0.62	0.72	0.72	0.11	-	-	-	
								5' - 10'	0.71	0.77	0.81	0.11	-	-	-	
15'	1.01	1.16	1.17					0.11	-	-	-					
20'	1.27	1.56	1.45					0.11	-	-	-					
9 to 10 to 11	9 9.5 9 10.5 9 11.5 9	8 to 12	25'		1.45	1.65	1.57	0.11	-	-	-					
			30'		1.59	1.72	1.66	0.11	-	-	-					
			9' x 9'		9	9	4 to 12	0.33' - <2'	0.68	0.88	0.76	0.22	0.29	0.55	0.57	-
								2' - <3'	0.68	0.88	0.78	0.18	-	-	-	
								3' - <5'	0.68	0.75	0.78	0.18	-	-	-	
								5' - 10'	0.79	0.82	0.88	0.17	-	-	-	
15'	1.11	1.22		1.26				0.13	-	-	-					
20'	1.37	1.64		1.54				0.13	-	-	-					
9 to 10 to 11	9 9.5 9 10.5 9 11.5 9.5	8 to 12		25'	1.56	1.73	1.65	0.13	-	-	-					
				30'	1.56	1.73	1.68	0.12	-	-	-					

See General Note 5

TABLE 13B - STANDARD PRECAST BOX CULVERT DESIGNS (3" COVER) - 9' SPANS

SPAN x RISE (S) (R) (Ft.)	SLAB / WALL THICKNESS				DESIGN EARTH COVER ABOVE TOP SLAB	REINFORCEMENT AREAS (sq. in./Ft.)									As1 EXT. LENGTH (M) (in.)	
	TOP (Tt) (in.)	BOT. (Tb) (in.)	SIDE (Tw) (in.)	HAUNCH (H) (in.)		As1	As2	As3	As4	As5	As7	As8	As9			
9' x 5'	10	10	10	4 to 12	0.33' - <2'	0.49	0.65	0.57	0.24	0.24	0.40	0.48	-			
					2' - <3'	0.49	0.65	0.57	0.12	-	-	-				
					3' - <5'	0.46	0.54	0.53	0.12	-	-	-				
					5' - 10'	0.52	0.50	0.51	0.12	-	-	-				
					15'	0.75	0.74	0.75	0.12	-	-	-				
					20'	0.98	1.01	1.00	0.12	-	-	-				
	10 to 10.5 to 11	10 10.5 10 11.5 10	8 to 12	25'	1.21	1.27	1.19	0.12	-	-	-					
				30'	1.30	1.36	1.30	0.12	-	-	-					
				9' x 6'	10	10	4 to 12	0.33' - <2'	0.48	0.68	0.60	0.24	0.24	0.39	0.48	-
								2' - <3'	0.48	0.68	0.60	0.12	-	-	-	
								3' - <5'	0.45	0.57	0.56	0.12	-	-	-	
								5' - 10'	0.52	0.53	0.56	0.12	-	-	-	
15'	0.74	0.79	0.81					0.12	-	-	-					
20'	0.97	1.07	1.07					0.12	-	-	-					
10 to 10.5 to 11	10 10.5 10 11.5 10	8 to 12	25'		1.18	1.35	1.28	0.12	-	-	-					
			30'		1.27	1.44	1.38	0.12	-	-	-					
			9' x 7'		10	10	4 to 12	0.33' - <2'	0.49	0.70	0.63	0.24	0.24	0.39	0.49	-
								2' - <3'	0.49	0.70	0.63	0.12	-	-	-	
								3' - <5'	0.46	0.59	0.59	0.12	-	-	-	
								5' - 10'	0.54	0.57	0.60	0.12	-	-	-	
15'	0.75	0.84		0.86				0.12	-	-	-					
20'	0.98	1.13		1.14				0.12	-	-	-					
10 to 10.5 to 11	10 10.5 10 11.5 10	8 to 12		25'	1.18	1.43	1.36	0.12	-	-	-					
				30'	1.28	1.52	1.46	0.12	-	-	-					
				9' x 8'	10	10	4 to 12	0.33' - <2'	0.51	0.72	0.65	0.24	0.24	0.39	0.51	-
								2' - <3'	0.51	0.72	0.65	0.12	-	-	-	
								3' - <5'	0.49	0.61	0.62	0.12	-	-	-	
								5' - 10'	0.57	0.60	0.65	0.12	-	-	-	
15'	0.79	0.89	0.92					0.12	-	-	-					
20'	1.02	1.20	1.22					0.12	-	-	-					
10 to 10.5 to 11	10 10.5 10 11.5 10	8 to 12	25'		1.21	1.50	1.44	0.12	-	-	-					
			30'		1.33	1.59	1.54	0.12	-	-	-					
			9' x 9'		10	10	4 to 12	0.33' - <2'	0.54	0.74	0.68	0.24	0.24	0.41	0.54	-
								2' - <3'	0.54	0.74	0.68	0.15	-	-	-	
								3' - <5'	0.53	0.63	0.64	0.13	-	-	-	
								5' - 10'	0.62	0.64	0.70	0.12	-	-	-	
15'	0.85	0.94		0.99				0.12	-	-	-					
20'	1.09	1.26		1.29				0.12	-	-	-					
10 to 10.5 to 11	10 10.5 10 11.5 10	8 to 12		25'	1.28	1.56	1.52	0.12	-	-	-					
				30'	1.42	1.66	1.66	0.12	-	-	-					

See General Note 5

- NOTES:  
 1. See Sheet 2 for General Notes.  
 2. See Sheet 7 for Reinforcing Details and dimension locations.  
 3. See Sheet 14 for WWR Bending Diagrams.

12/17/2015 11:13:37 AM

TABLE 14 - STANDARD PRECAST BOX CULVERT DESIGNS (3" COVER) - 10' SPANS

SPAN x RISE (S) (R) (Ft.)	SLAB / WALL THICKNESS				DESIGN EARTH COVER ABOVE TOP SLAB	REINFORCEMENT AREAS (sq. in./Ft.)									As1 EXT. LENGTH (M) (in.)		
	TOP (Tt) (in.)	BOT. (Tb) (in.)	SIDE (Tw) (in.)	HAUNCH (H) (in.)		As1	As2	As3	As4	As5	As7	As8	As9				
10' x 5'	10	10	10	4 to 12	0.33' - <2'	0.60	0.73	0.61	0.24	0.24	0.50	0.57	-				
					2' - <3'	0.60	0.73	0.61	0.12	-	-	-	58				
					3' - <5'	0.57	0.64	0.58	0.12	-	-	-	53				
					5' - 10'	0.65	0.60	0.60	0.12	-	-	-	52				
					15'	0.94	0.90	0.89	0.12	-	-	-	47				
					20'	1.24	1.23	1.19	0.12	-	-	-	47				
	10	10	10	8 to 12	25'	1.39	1.37	1.28	0.12	-	-	-	47				
					30'	1.38	1.43	1.41	0.12	-	-	-	47				
					10	10	10	4 to 12	0.33' - <2'	0.58	0.75	0.64	0.24	0.24	0.48	0.56	-
									2' - <3'	0.58	0.75	0.64	0.12	-	-	-	58
									3' - <5'	0.56	0.67	0.62	0.12	-	-	-	52
									5' - 10'	0.64	0.64	0.65	0.12	-	-	-	52
15'	0.92	0.96	0.95	0.12					-	-	-	47					
20'	1.21	1.31	1.27	0.12					-	-	-	47					
10	10	10	8 to 12	25'	1.35	1.44	1.36	0.12	-	-	-	47					
				30'	1.35	1.51	1.49	0.12	-	-	-	47					
				10	10	10	4 to 12	0.33' - <2'	0.57	0.78	0.67	0.24	0.24	0.48	0.57	-	
								2' - <3'	0.57	0.78	0.67	0.12	-	-	-	58	
								3' - <5'	0.58	0.70	0.65	0.12	-	-	-	58	
								5' - 10'	0.65	0.68	0.70	0.12	-	-	-	52	
15'	0.92	1.02	1.02					0.12	-	-	-	47					
20'	1.21	1.38	1.35					0.12	-	-	-	47					
10	10	10	8 to 12	25'	1.33	1.52	1.44	0.12	-	-	-	47					
				30'	1.38	1.58	1.57	0.12	-	-	-	47					
				10	10	10	4 to 12	0.33' - <2'	0.58	0.80	0.70	0.24	0.26	0.48	0.58	-	
								2' - <3'	0.58	0.80	0.70	0.12	-	-	-	64	
								3' - <5'	0.60	0.72	0.68	0.12	-	-	-	58	
								5' - 10'	0.67	0.72	0.75	0.12	-	-	-	52	
15'	0.95	1.08	1.08					0.12	-	-	-	47					
20'	1.24	1.45	1.44					0.12	-	-	-	47					
10	10	10	8 to 12	25'	1.36	1.59	1.52	0.12	-	-	-	47					
				30'	1.45	1.64	1.64	0.12	-	-	-	47					
				10	10	10	4 to 12	0.33' - <2'	0.61	0.82	0.73	0.24	0.26	0.50	0.61	-	
								2' - <3'	0.61	0.82	0.73	0.14	-	-	-	70	
								3' - <5'	0.64	0.75	0.73	0.13	-	-	-	64	
								5' - 10'	0.72	0.77	0.80	0.12	-	-	-	58	
15'	1.00	1.13	1.15					0.12	-	-	-	52					
20'	1.30	1.53	1.52					0.12	-	-	-	47					
10	10	10	8 to 12	25'	1.42	1.66	1.60	0.12	-	-	-	47					
				30'	1.57	1.70	1.72	0.12	-	-	-	47					
				10	10	10	4 to 12	0.33' - <2'	0.66	0.84	0.75	0.24	0.27	0.52	0.65	-	
								2' - <3'	0.66	0.84	0.75	0.20	-	-	-	79	
								3' - <5'	0.70	0.77	0.79	0.19	-	-	-	70	
								5' - 10'	0.79	0.81	0.87	0.18	-	-	-	64	
15'	1.09	1.19	1.23					0.15	-	-	-	52					
20'	1.40	1.61	1.61					0.14	-	-	-	52					
10	10	10	8 to 12	25'	1.53	1.74	1.68	0.14	-	-	-	47					
				30'	1.60	1.71	1.74	0.14	-	-	-	47					

See General Note 5

TABLE 15 - STANDARD PRECAST BOX CULVERT DESIGNS (3" COVER) - 11' SPANS

SPAN x RISE (S) (R) (Ft.)	SLAB / WALL THICKNESS				DESIGN EARTH COVER ABOVE TOP SLAB	REINFORCEMENT AREAS (sq. in./Ft.)									As1 EXT. LENGTH (M) (in.)		
	TOP (Tt) (in.)	BOT. (Tb) (in.)	SIDE (Tw) (in.)	HAUNCH (H) (in.)		As1	As2	As3	As4	As5	As7	As8	As9				
11' x 4'	11	11	11	4 to 12	0.33' - <2'	0.60	0.66	0.54	0.27	0.27	0.52	0.56	-				
					2' - <3'	0.60	0.66	0.54	0.14	-	-	-	62				
					3' - <5'	0.60	0.61	0.53	0.14	-	-	-	62				
					5' - 10'	0.79	0.63	0.62	0.14	-	-	-	55				
					15'	1.01	0.82	0.79	0.14	-	-	-	55				
					20'	1.34	1.11	1.06	0.14	-	-	-	55				
	11	11	11	8 to 12	25'	1.52	1.27	1.23	0.14	-	-	-	55				
					30'	1.54	1.37	1.34	0.14	-	-	-	50				
					11	11	11	4 to 12	0.33' - <2'	0.57	0.71	0.60	0.27	0.27	0.47	0.53	-
									2' - <3'	0.56	0.71	0.60	0.14	-	-	-	62
									3' - <5'	0.56	0.67	0.59	0.14	-	-	-	55
									5' - 10'	0.73	0.71	0.72	0.14	-	-	-	55
15'	0.92	0.92	0.91	0.14					-	-	-	50					
20'	1.21	1.25	1.21	0.14					-	-	-	50					
11	11	11	8 to 12	25'	1.37	1.43	1.39	0.14	-	-	-	50					
				30'	1.39	1.53	1.50	0.14	-	-	-	50					
				11	11	11	4 to 12	0.33' - <2'	0.55	0.76	0.66	0.27	0.27	0.46	0.55	-	
								2' - <3'	0.55	0.76	0.66	0.14	-	-	-	62	
								3' - <5'	0.54	0.72	0.65	0.14	-	-	-	62	
								5' - 10'	0.73	0.79	0.82	0.14	-	-	-	55	
15'	0.93	1.03	1.03					0.14	-	-	-	50					
20'	1.21	1.39	1.36					0.14	-	-	-	50					
11	11	11	8 to 12	25'	1.34	1.56	1.50	0.14	-	-	-	50					
				30'	1.41	1.66	1.65	0.14	-	-	-	50					
				11	11	11	4 to 12	0.33' - <2'	0.60	0.81	0.71	0.27	0.27	0.48	0.60	-	
								2' - <3'	0.60	0.81	0.71	0.15	-	-	-	75	
								3' - <5'	0.61	0.77	0.70	0.14	-	-	-	69	
								5' - 10'	0.80	0.88	0.93	0.14	-	-	-	62	
15'	1.01	1.13	1.15					0.14	-	-	-	55					
20'	1.30	1.52	1.52					0.14	-	-	-	50					
11	11	11	8 to 12	25'	1.42	1.70	1.65	0.14	-	-	-	50					
				30'	1.53	1.77	1.74	0.14	-	-	-	50					
				11	11	11	4 to 12	0.33' - <2'	0.64	0.83	0.74	0.27	0.27	0.51	0.64	-	
								2' - <3'	0.64	0.83	0.74	0.21	-	-	-	86	
								3' - <5'	0.67	0.79	0.75	0.21	-	-	-	75	
								5' - 10'	0.88	0.93	0.99	0.19	-	-	-	69	
15'	1.09	1.19	1.23					0.16	-	-	-	55					
20'	1.40	1.59	1.60					0.15	-	-	-	55					
11	11	11	8 to 12	25'	1.54	1.77	1.73	0.15	-	-	-	50					
				30'	1.57	1.77	1.76	0.14	-	-	-	50					

See General Note 5

NOTES:

- 1. See Sheet 2 for General Notes.
- 2. See Sheet 7 for Reinforcing Details and dimension locations.
- 3. See Sheet 14 for WWR Bending Diagrams.

TABLE 16 - STANDARD PRECAST BOX CULVERT DESIGNS (3" COVER) - 12' SPANS

SPAN x RISE (S) (R) (Ft.)	SLAB / WALL THICKNESS				DESIGN EARTH COVER ABOVE TOP SLAB	REINFORCEMENT AREAS (sq. in./Ft.)								As1 EXT. LENGTH (M) (in.)
	TOP (Tt) (in.)	BOT. (Tb) (in.)	SIDE (Tw) (in.)	HAUNCH (H) (in.)		As1	As2	As3	As4	As5	As7	As8	As9	
12' x 4'	12	12	12	4 to 12	0.33' - <2'	0.59	0.64	0.51	0.29	0.29	0.52	0.55	-	
					2' - <3'	0.60	0.64	0.51	0.15	-	-	-		
					3' - <5'	0.60	0.61	0.51	0.15	-	-	-		
					5' - 10'	0.81	0.61	0.61	0.15	-	-	-		
					15'	1.04	0.80	0.77	0.15	-	-	-		
					20'	1.37	1.08	1.03	0.15	-	-	-		
12' x 6'	12	12	12	4 to 12	0.33' - <2'	0.56	0.70	0.57	0.29	0.29	0.47	0.52	-	
					2' - <3'	0.56	0.70	0.57	0.15	-	-	-		
					3' - <5'	0.56	0.67	0.57	0.15	-	-	-		
					5' - 10'	0.74	0.69	0.70	0.15	-	-	-		
					15'	0.94	0.90	0.88	0.15	-	-	-		
					20'	1.23	1.22	1.17	0.15	-	-	-		
12' x 8'	12	12	12	4 to 12	0.33' - <2'	0.55	0.75	0.63	0.29	0.29	0.45	0.53	-	
					2' - <3'	0.55	0.75	0.63	0.15	-	-	-		
					3' - <5'	0.55	0.73	0.63	0.15	-	-	-		
					5' - 10'	0.73	0.77	0.79	0.15	-	-	-		
					15'	0.93	1.00	0.99	0.15	-	-	-		
					20'	1.21	1.35	1.31	0.15	-	-	-		
12' x 10'	12	12	12	4 to 12	0.33' - <2'	0.57	0.80	0.68	0.29	0.29	0.46	0.57	-	
					2' - <3'	0.57	0.80	0.68	0.15	-	-	-		
					3' - <5'	0.59	0.77	0.68	0.15	-	-	-		
					5' - 10'	0.78	0.85	0.89	0.15	-	-	-		
					15'	0.98	1.10	1.11	0.15	-	-	-		
					20'	1.26	1.47	1.45	0.15	-	-	-		
12' x 12'	12	12	12	4 to 12	0.33' - <2'	0.65	0.84	0.73	0.29	0.29	0.50	0.65	-	
					2' - <3'	0.65	0.84	0.73	0.23	-	-	-		
					3' - <5'	0.68	0.81	0.75	0.22	-	-	-		
					5' - 10'	0.90	0.94	1.01	0.21	-	-	-		
					15'	1.12	1.20	1.24	0.18	-	-	-		
					20'	1.42	1.60	1.61	0.16	-	-	-		

See General Note 5

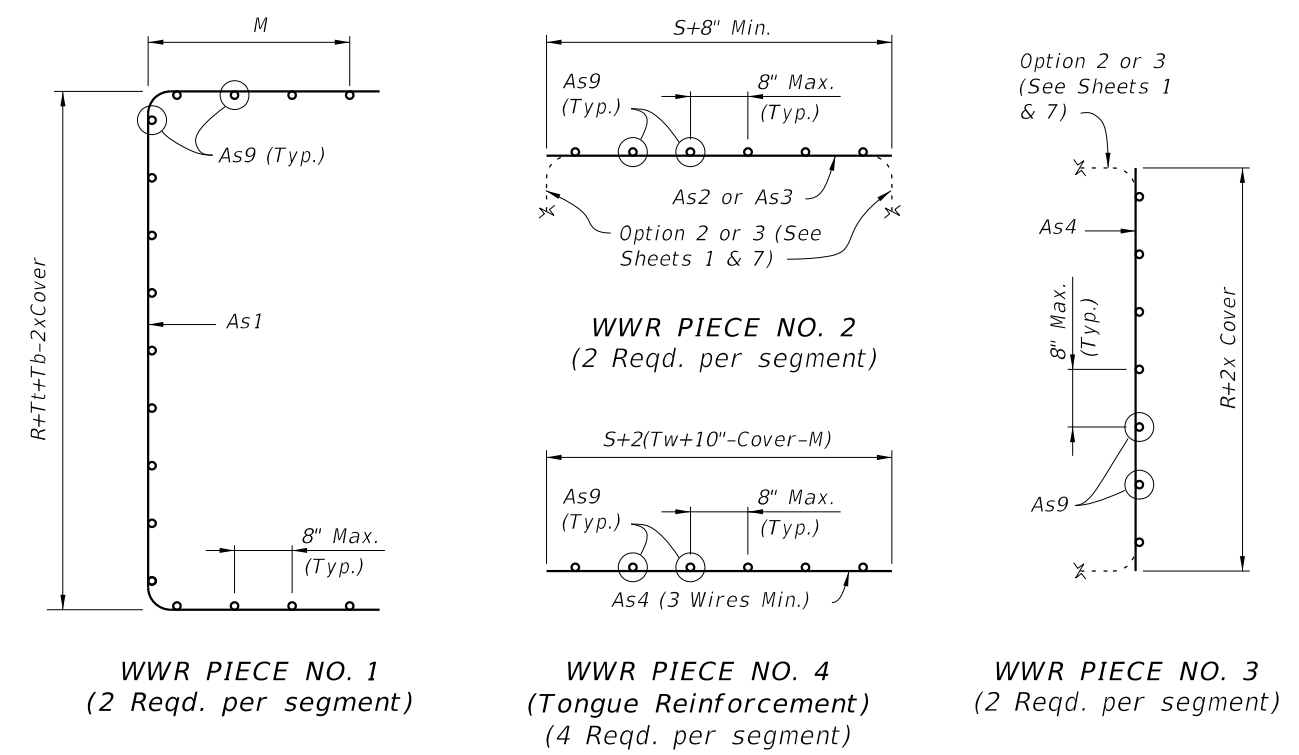

TYPE 2 BOX SECTION (DESIGN EARTH COVER 2' OR GREATER)

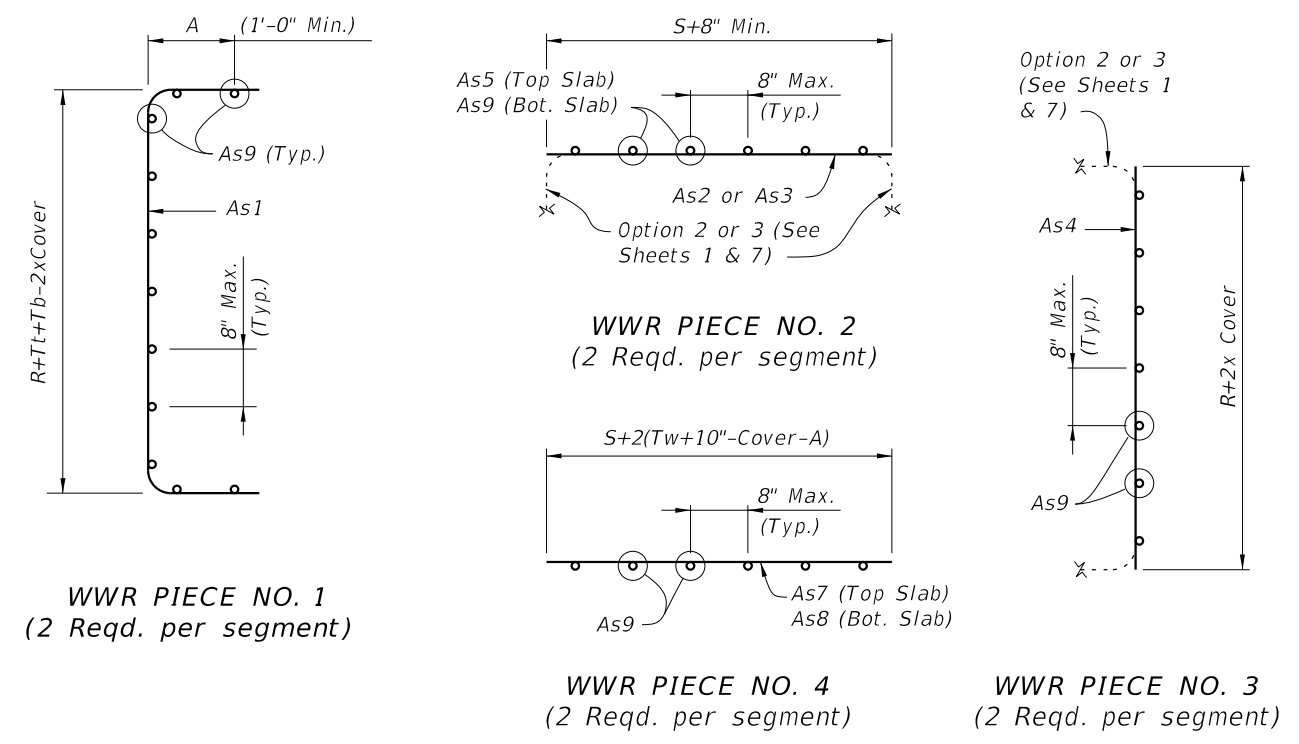

TYPE 1 BOX SECTION (DESIGN EARTH COVER LESS THAN 2')

- REINFORCEMENT NOTES:
1. Reinforcement bending dimensions are out-to-out.
  2. See General Notes 4, 5 and 6 on Sheet 2.
  3. See Tables 1 thru 16 for dimensions M, R, S, Tb, Tt and Tw.
  4. Dimension "A" is determined by the Manufacturer in accordance with the requirements of Detail "B" on Sheets 1 and 7.

- NOTES:
1. See Sheet 2 of 14 for General Notes.
  2. See Sheet 7 of 14 for Reinforcing Details and dimension locations.

12/17/2015 11:13:38 AM