

PLAN VIEW
BASE PLATE

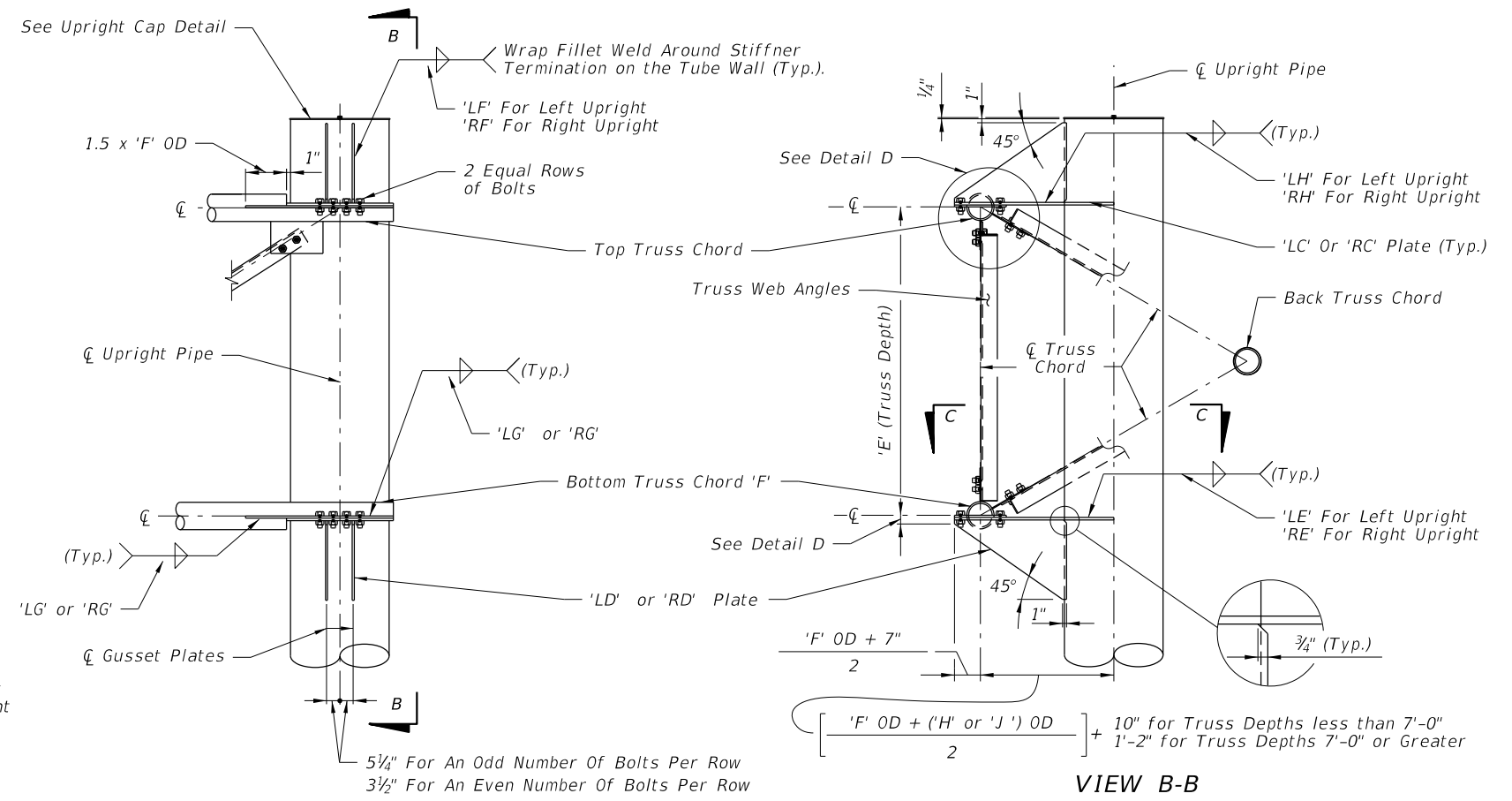

UPRIGHT-TRUSS CONNECTION DETAIL
RIGHT UPRIGHT SHOWN
(LEFT UPRIGHT SIMILAR)

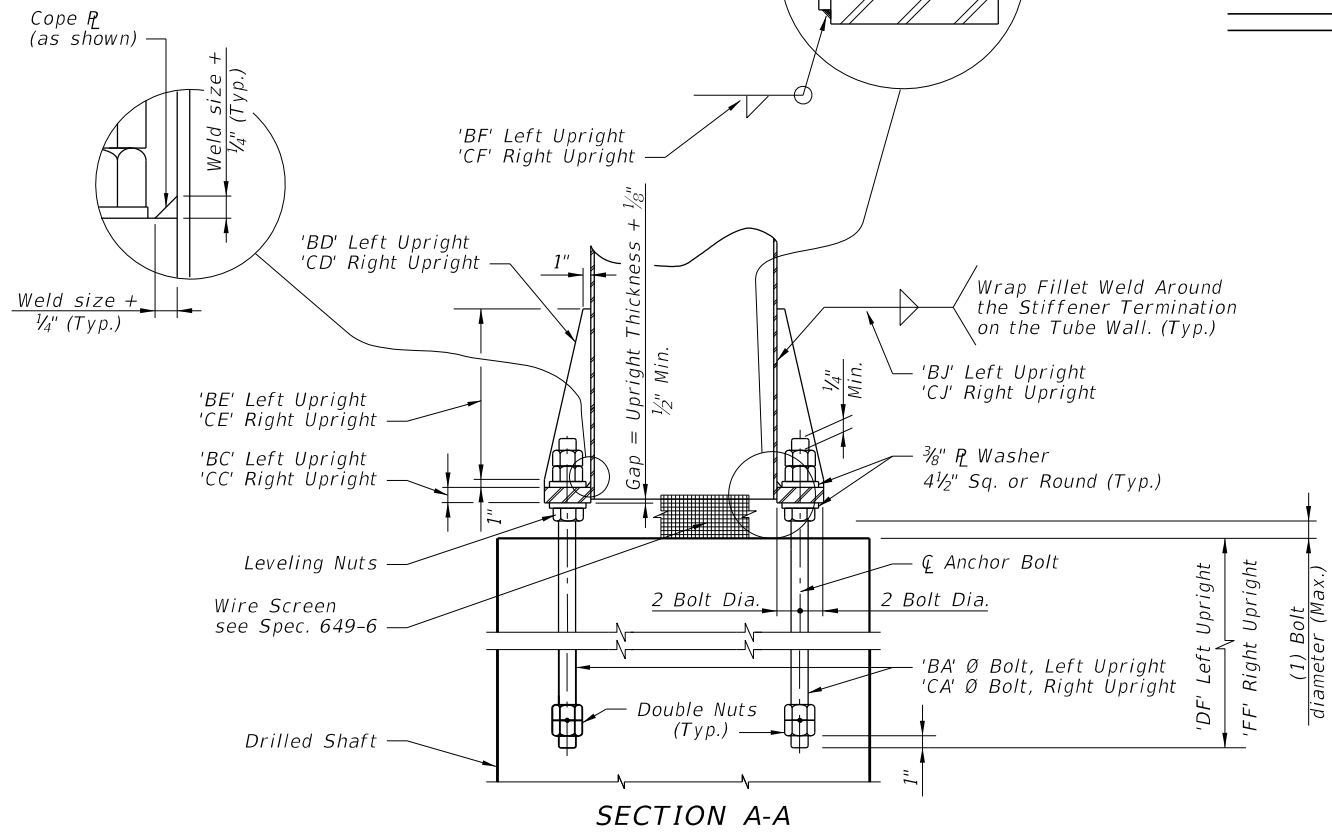

SECTION A-A

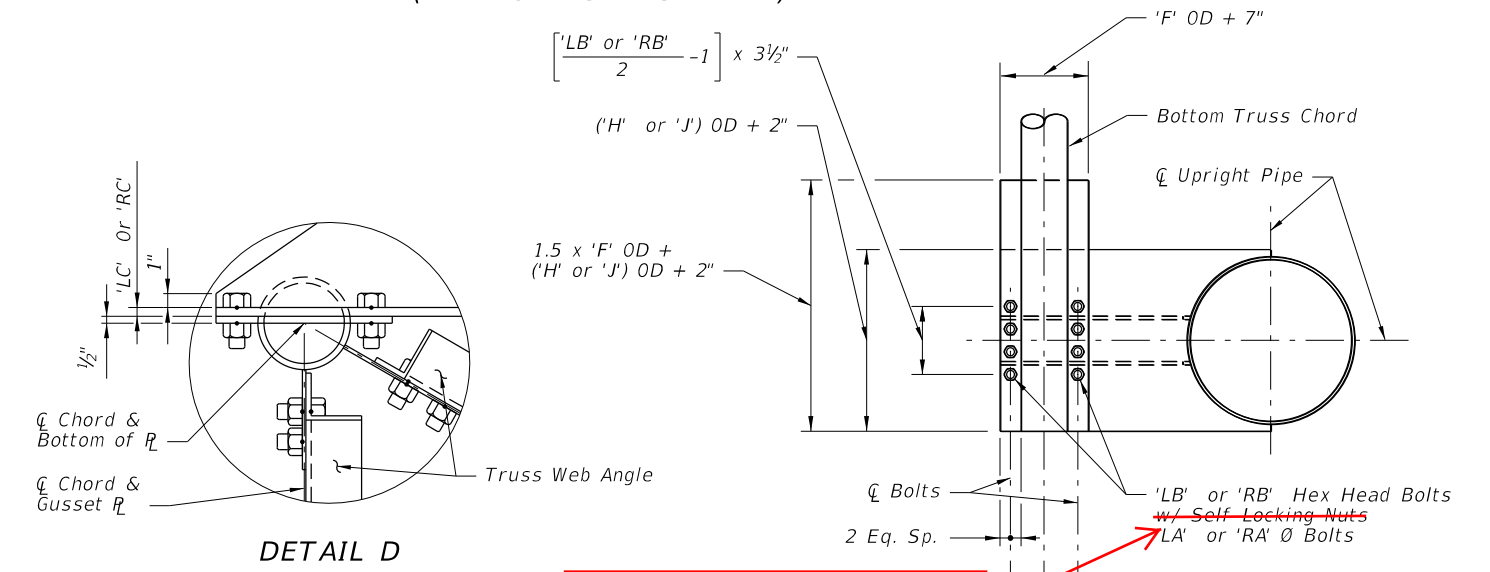

SECTION C-C
(With Gusset Plate and Angles omitted for clarity)

DELETE: Self Locking Nuts

NOTE:
Abbreviation
OD ~ Outside Diameter

11/30/2015 2:18:58 PM

LAST REVISION 07/01/15	REVISION	DESCRIPTION:	 FY 2016-17 DESIGN STANDARDS	SPAN SIGN STRUCTURE	INDEX NO. 11320	SHEET NO. 2 of 5
---------------------------	----------	--------------	------------------------------------	---------------------	--------------------	---------------------

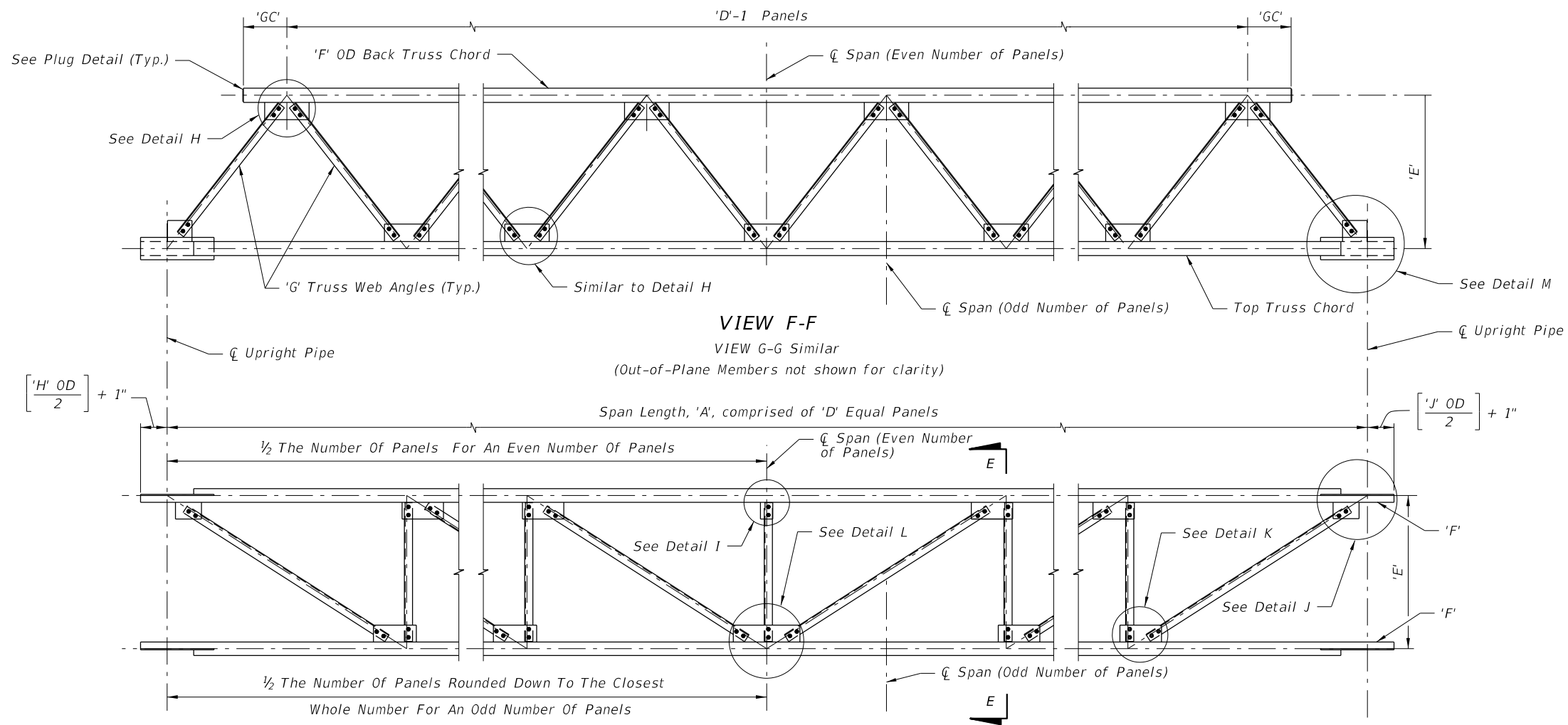

VIEW F-F
VIEW G-G Similar
(Out-of-Plane Members not shown for clarity)

Span Length, 'A', comprised of 'D' Equal Panels

FRONT OF TRUSS ELEVATION
(Back Truss Chord and attached Angles not shown for clarity)

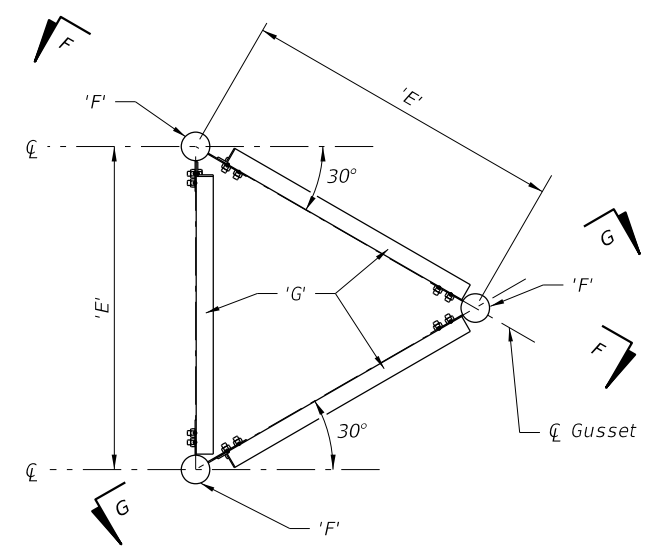

SECTION E-E

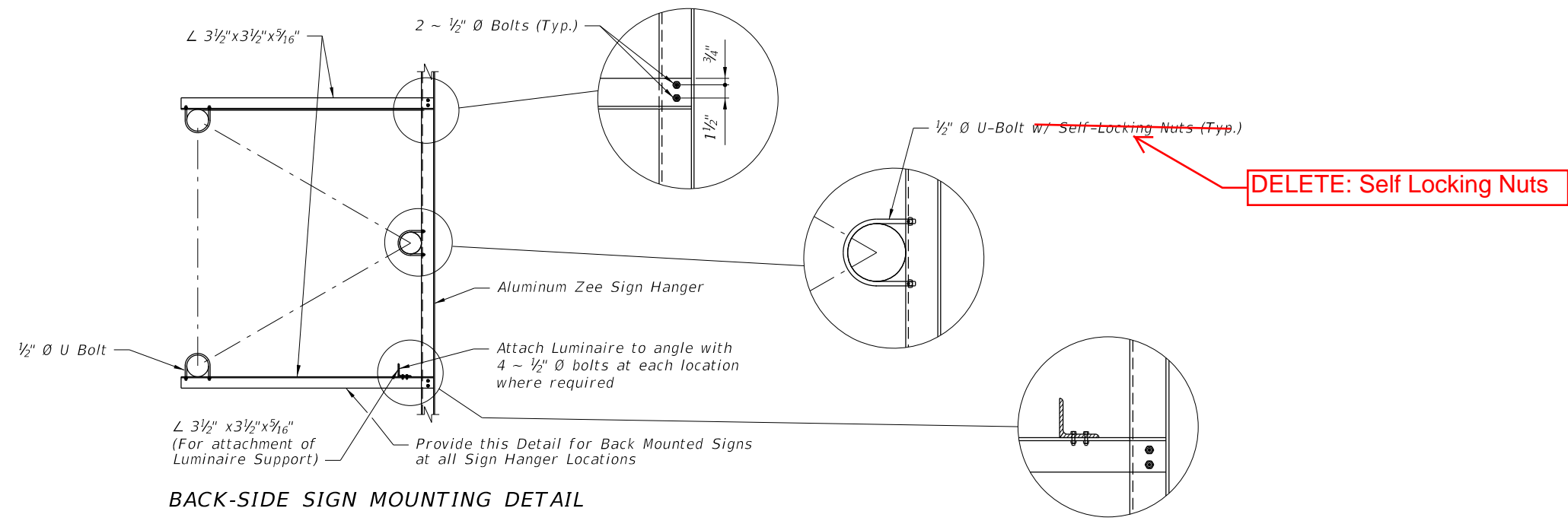

BACK-SIDE SIGN MOUNTING DETAIL

11/30/2015 2:18:59 PM

LAST REVISION 07/01/15	REVISION	DESCRIPTION:	 FY 2016-17 DESIGN STANDARDS	SPAN SIGN STRUCTURE	INDEX NO. 11320	SHEET NO. 3 of 5
---------------------------	----------	--------------	------------------------------------	---------------------	--------------------	---------------------

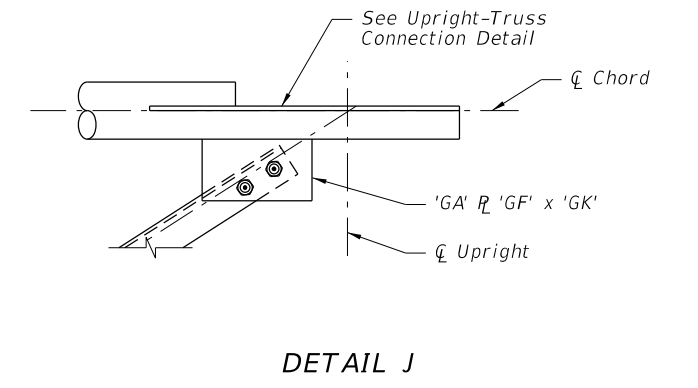
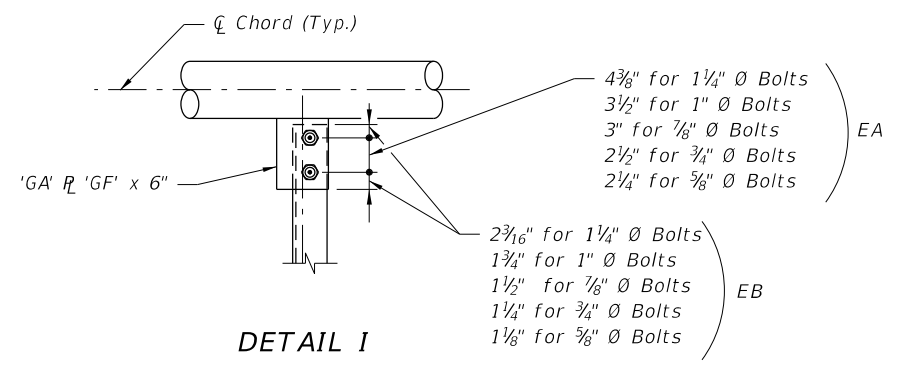
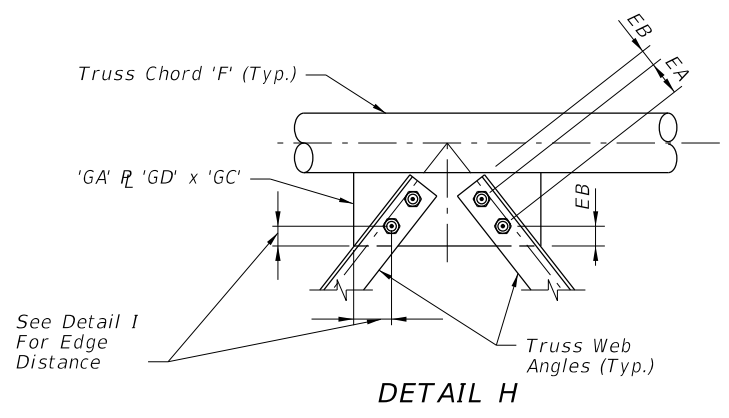

DELETE: Self Locking Nuts

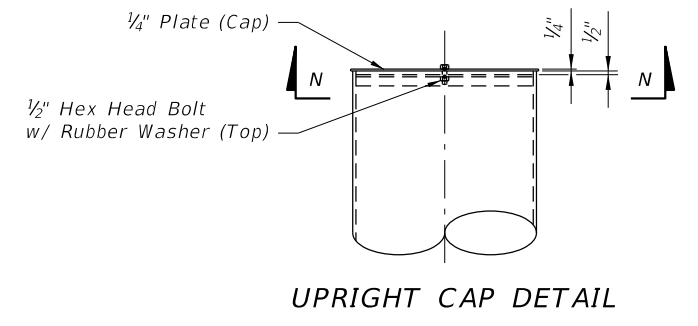
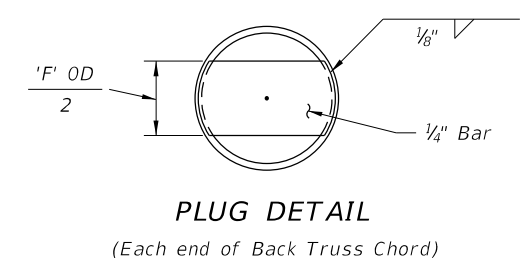
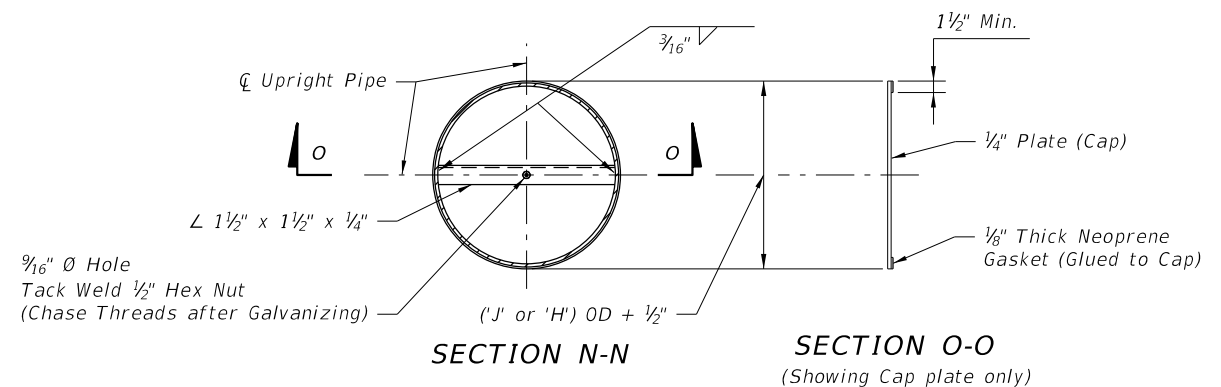
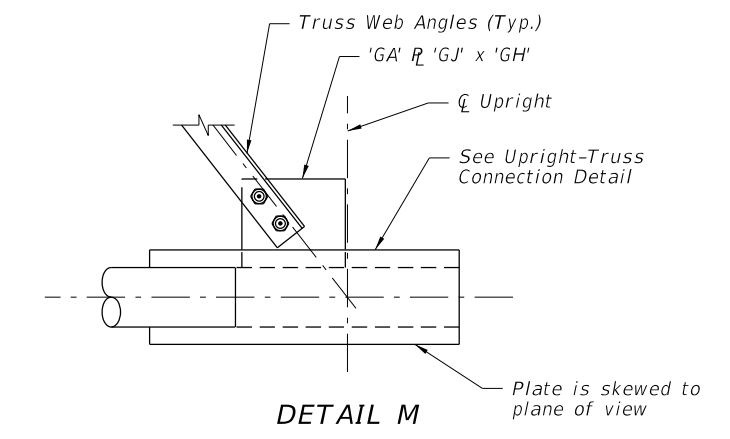
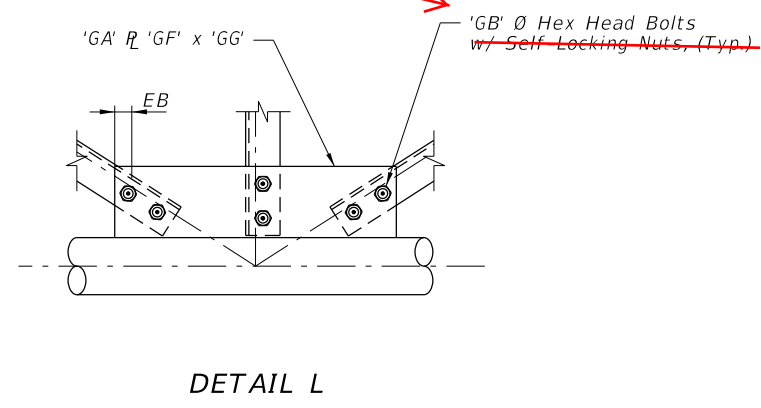
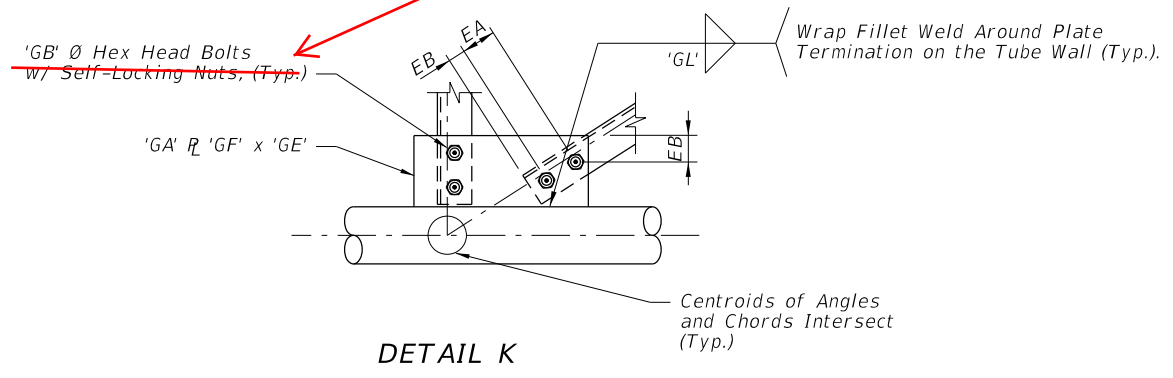

11/30/2015 2:19:00 PM

LAST REVISION 07/01/15	REVISION	DESCRIPTION:	FY 2016-17 DESIGN STANDARDS	SPAN SIGN STRUCTURE	INDEX NO. 11320	SHEET NO. 4 of 5
---------------------------	----------	--------------	--------------------------------	---------------------	--------------------	---------------------