

6/24/2015 7:53:35 AM

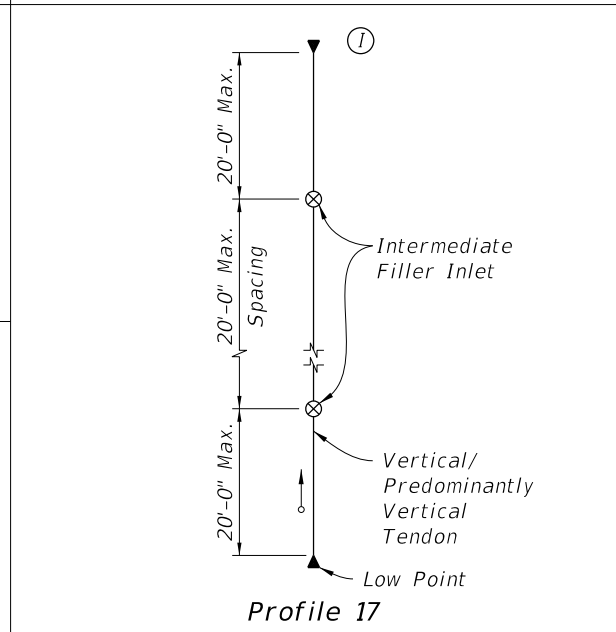
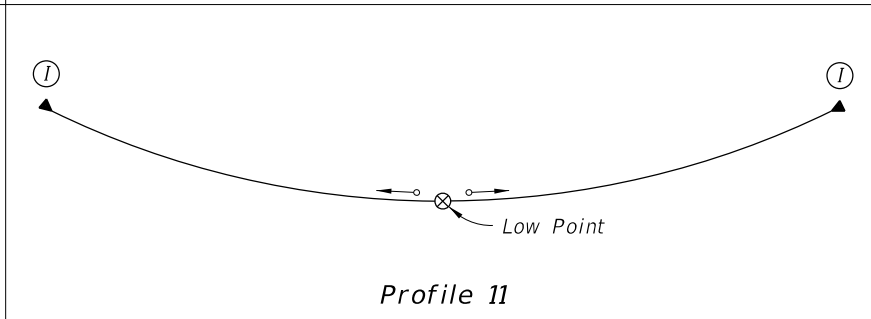
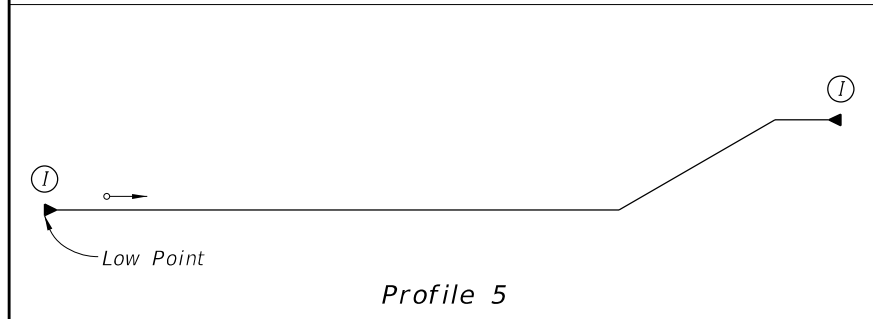
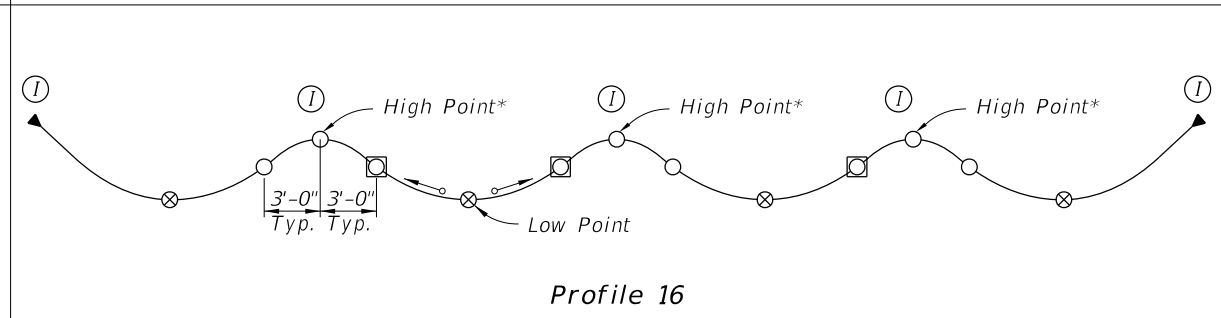
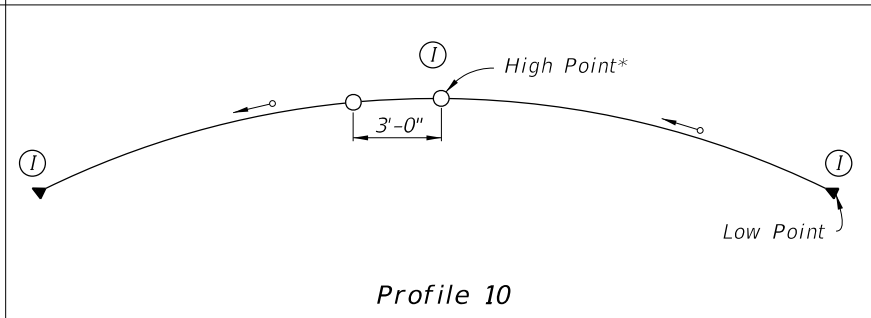
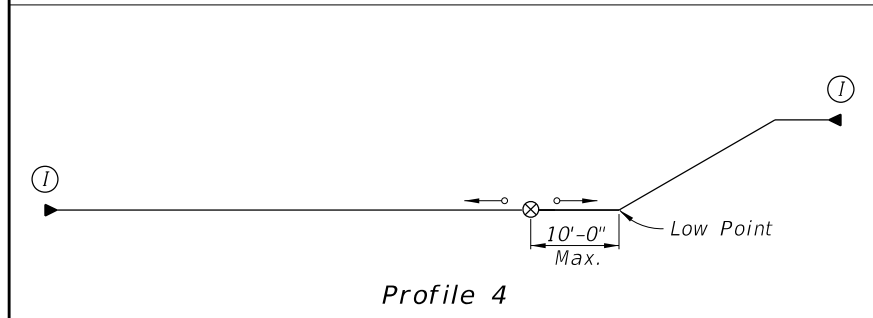
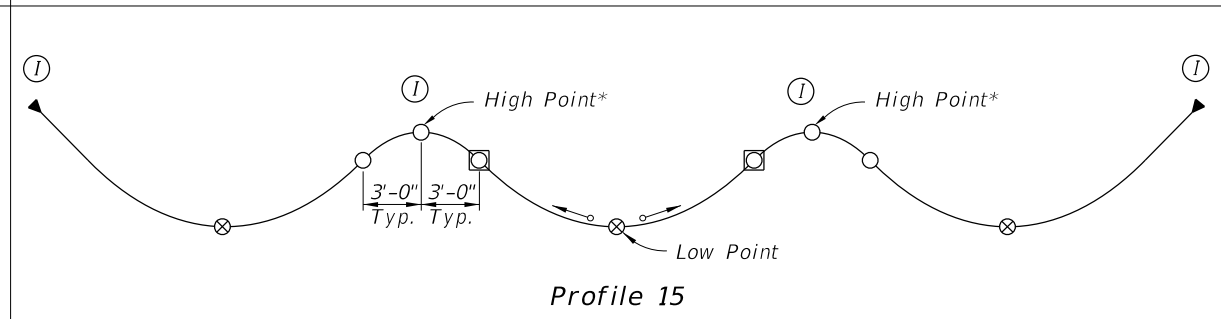
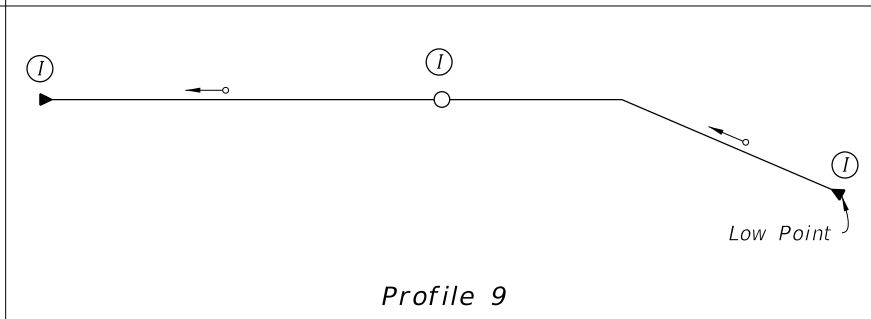
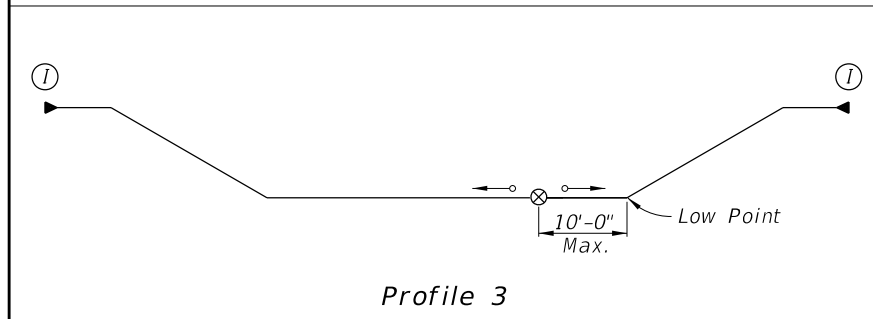
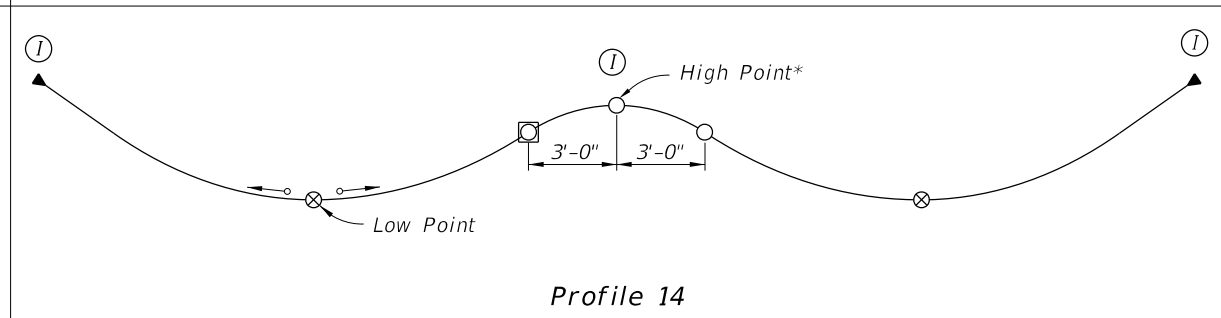
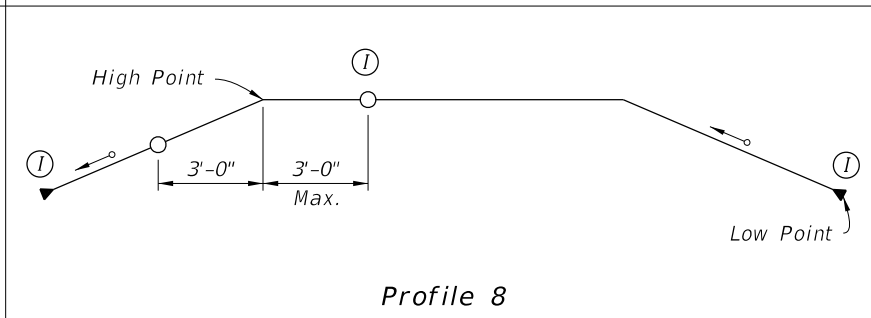
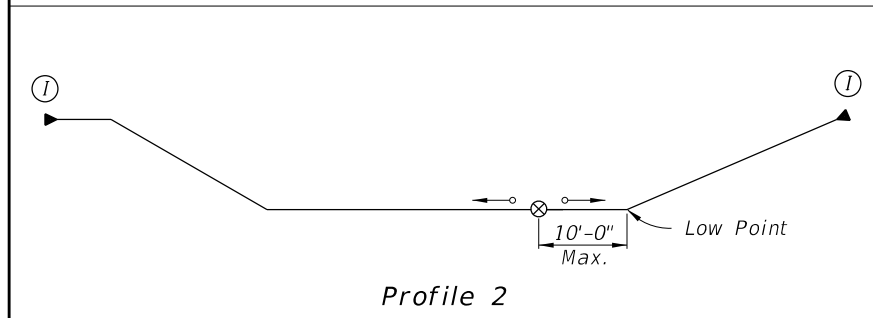
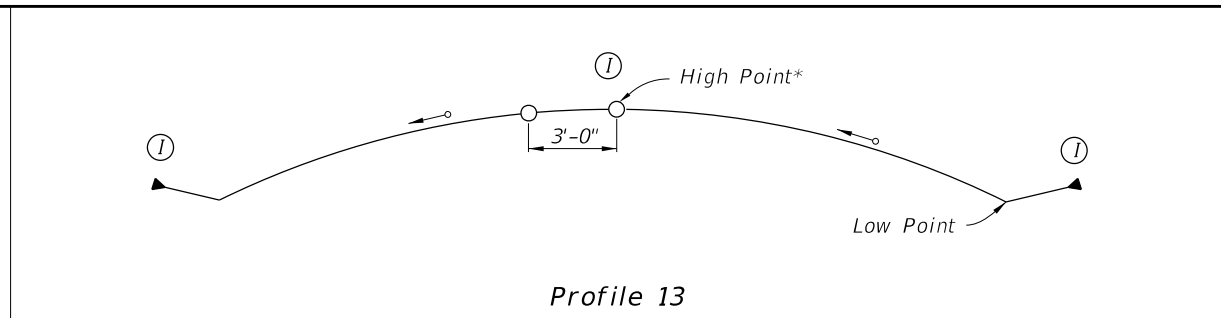
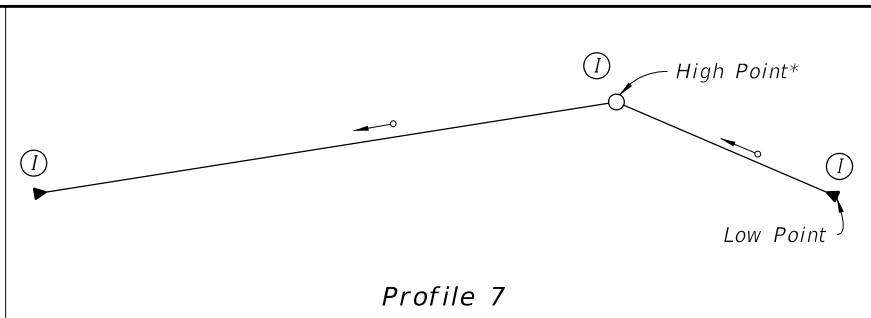
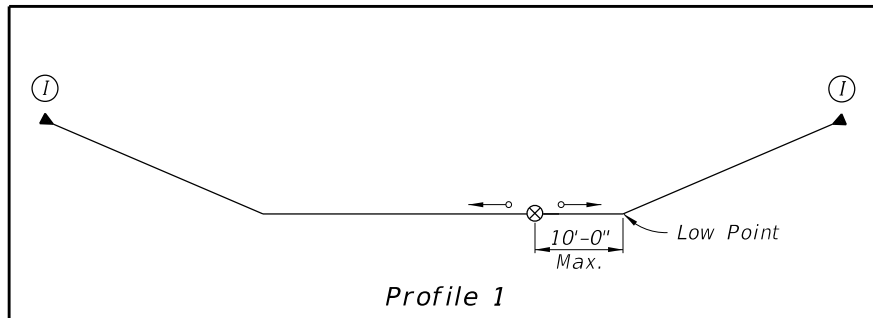

**LEGEND:**

- Strand or Bar Tendon
- ▶ Anchorage with Inlet/Outlet\*\*
- ⊗ Filler Inlet\*\*
- Filler Outlet
- ◻ Optional Filler Outlet
- ↔ Direction of Filler Flow\*\*
- Ⓜ Inspection Location

\* Adjust location to coincide with the true high point(s) of the tendon.

\*\* See Specifications Section 462 for vacuum assisted flexible filler injection requirements.

Note: See Specifications Section 462 for Drain location requirements.

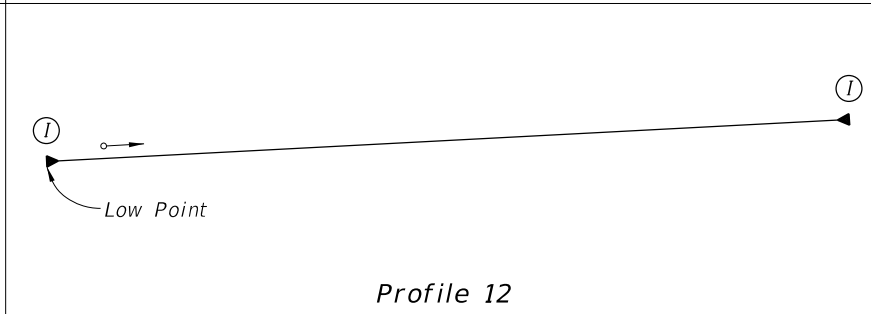
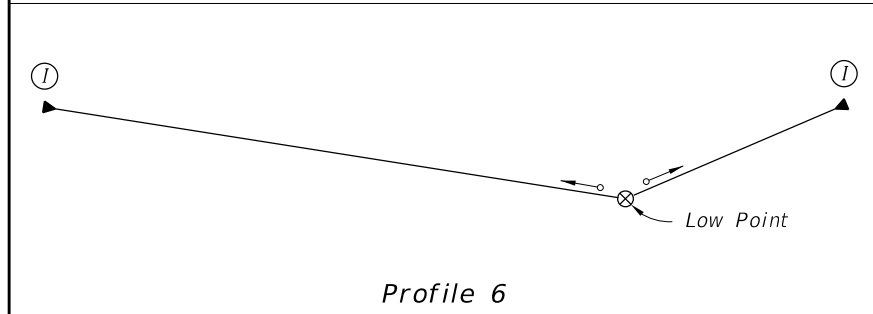

LAST REVISION 07/01/15	REVISION	DESCRIPTION:
---------------------------	----------	--------------

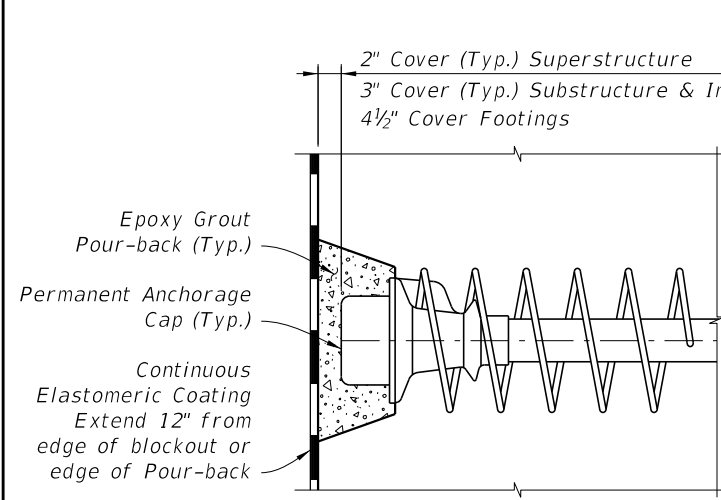

TYPE 1

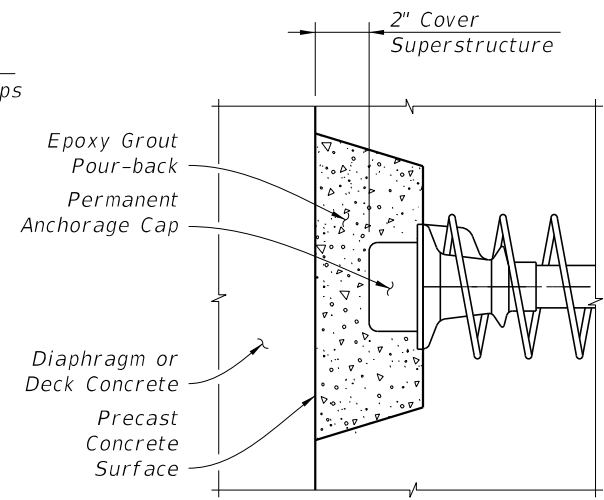

TYPE 2

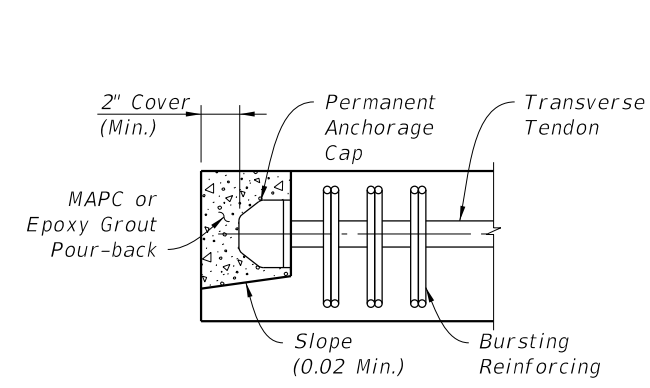

TYPE 7

Type 7 Notes:  
 1. Traffic or Pedestrian/Bicycle Railing not shown for clarity.  
 2. Where Pour-back is not protected by Traffic or Pedestrian/Bicycle Railing, Coat Pour-back with High Molecular Weight Methacrylate.

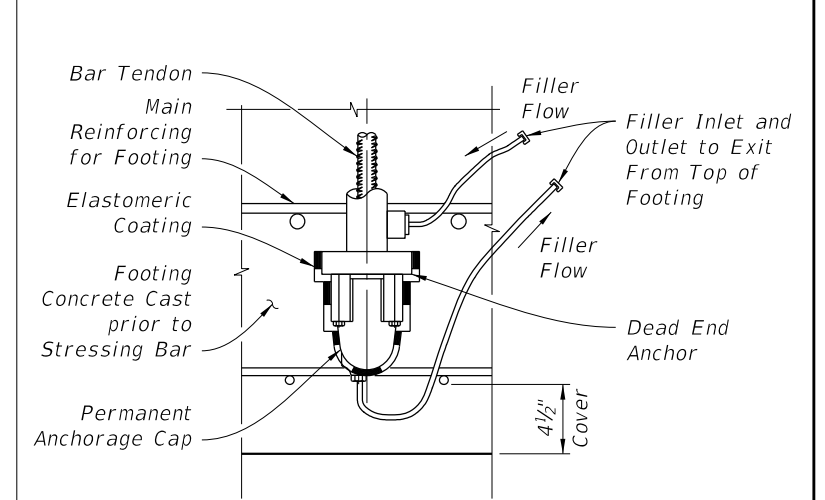

TYPE 8

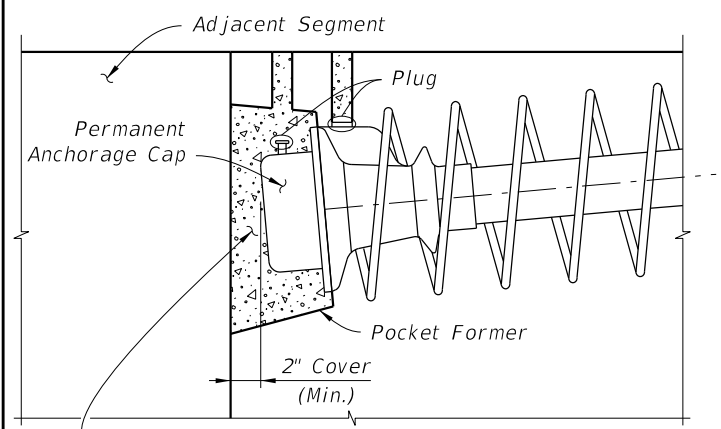

TYPE 3

Epoxy Grout Pour-back placed after permanent tendons anchored in adjacent segment have been stressed

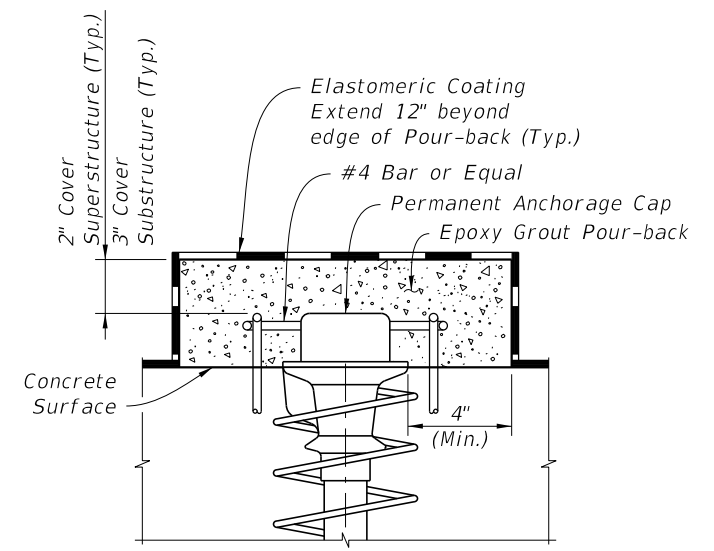

TYPE 4

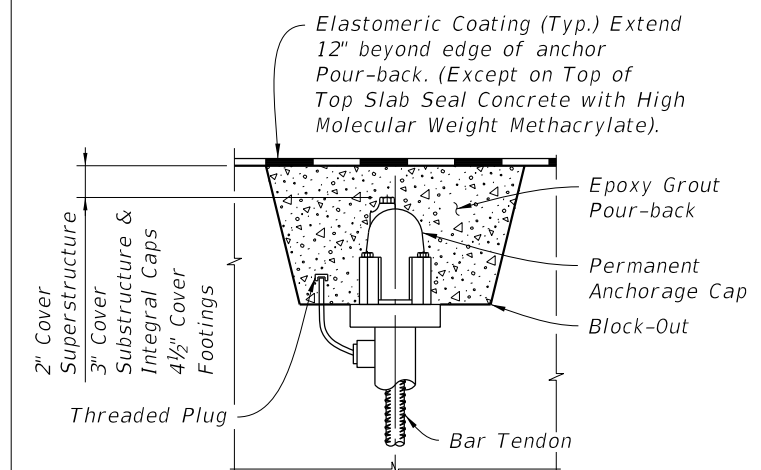

TYPE 9

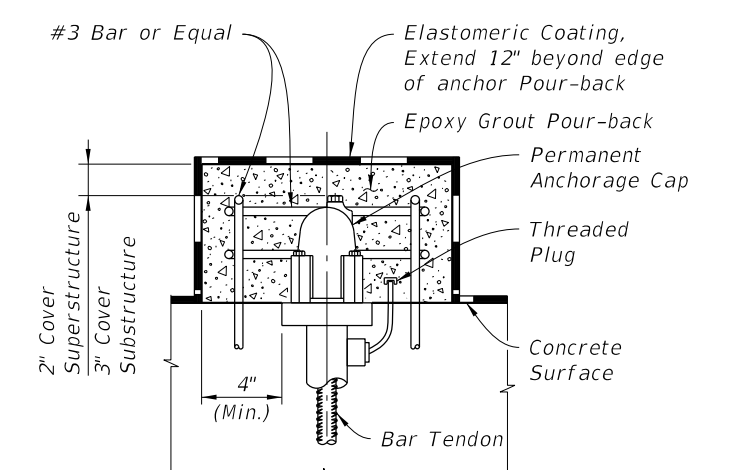

TYPE 10

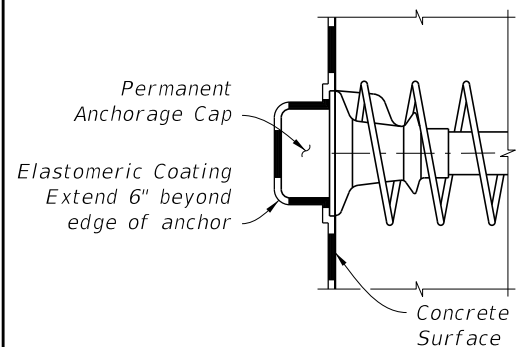

TYPE 5

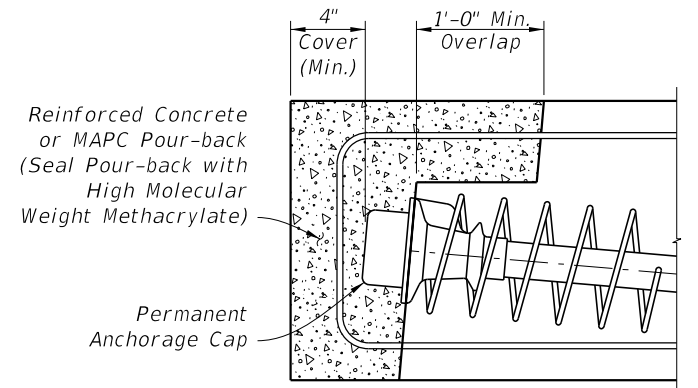

TYPE 6

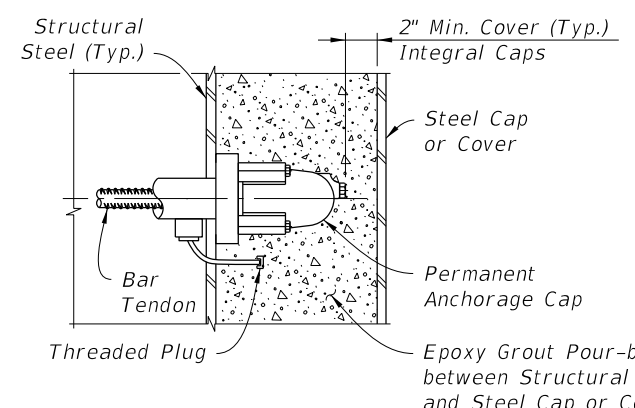

TYPE 11

(Shear Studs not Shown for Clarity)

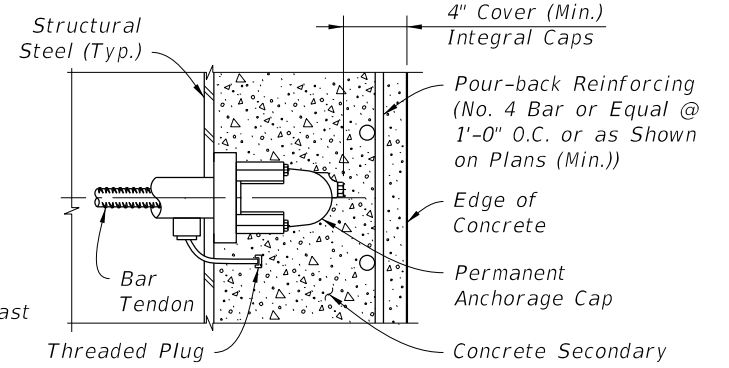

TYPE 12

(Shear Studs not Shown for Clarity)

ANCHORAGE PROTECTION FOR STRAND TENDONS

ANCHORAGE PROTECTION FOR BAR TENDONS

6/24/2015 7:53:50 AM

LAST REVISION 07/01/15	REVISION	DESCRIPTION:
---------------------------	----------	--------------

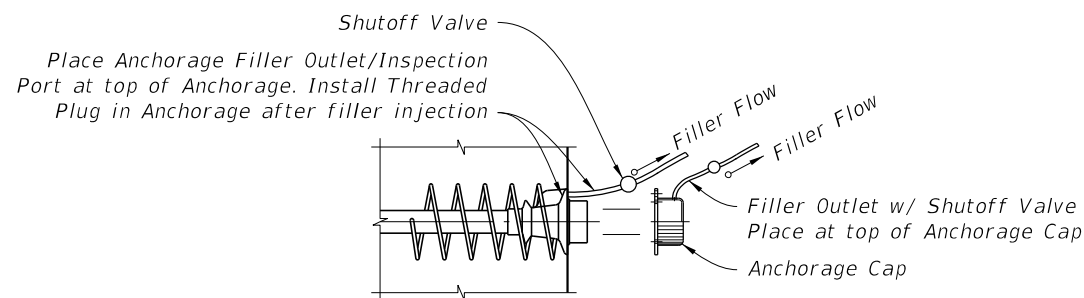

**FACE INSPECTED ANCHORAGE WITH FILLER OUTLET**

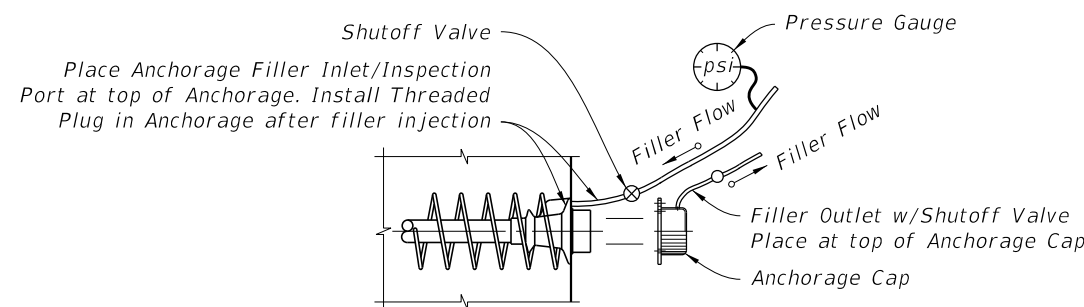

**FACE INSPECTED ANCHORAGE WITH FILLER INLET**

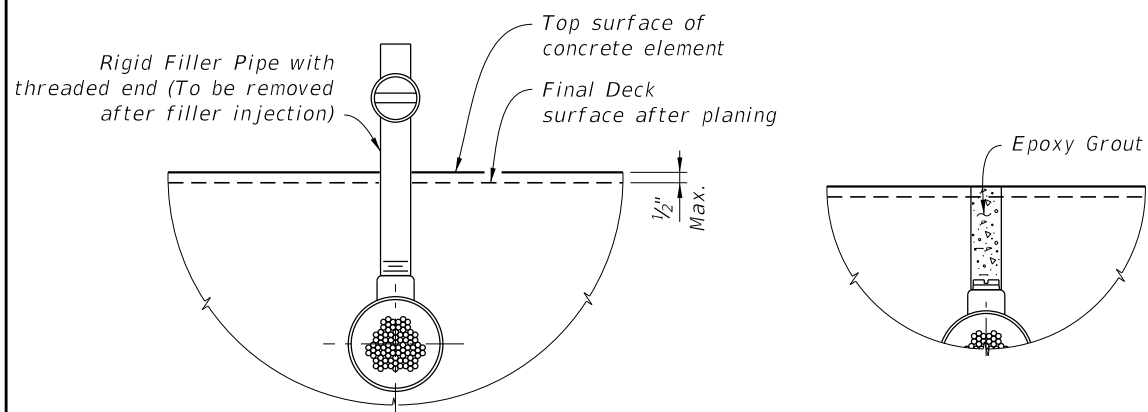

**1 FILLER OUTLET CONNECTION TO DUCT**

**3 FILLING POCKET**

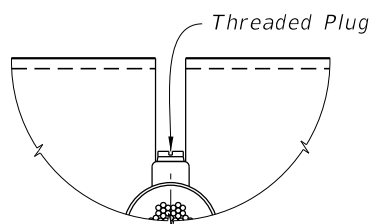

**2 POCKET PREPARATION**

**PROCEDURE:**

1. Remove Rigid Filler Pipe.
2. Inspect Tendon for voids as necessary.
3. Vacuum inject as required. If grout is used, allow grout to cure. If flexible filler is used, replace filler displaced by inspection. Remove pipe used for vacuum injecting.
4. Clean threads and rethread as required.
5. Install Threaded Plug into Outlet to form a tight fit.
6. Over-ream hole ( $\frac{1}{4}$ "  $\varnothing$  over-ream). Clean and roughen sides.
7. Fill Pocket with Epoxy Grout.

== FILLER OUTLET DETAIL AT HORIZONTAL SURFACES ==

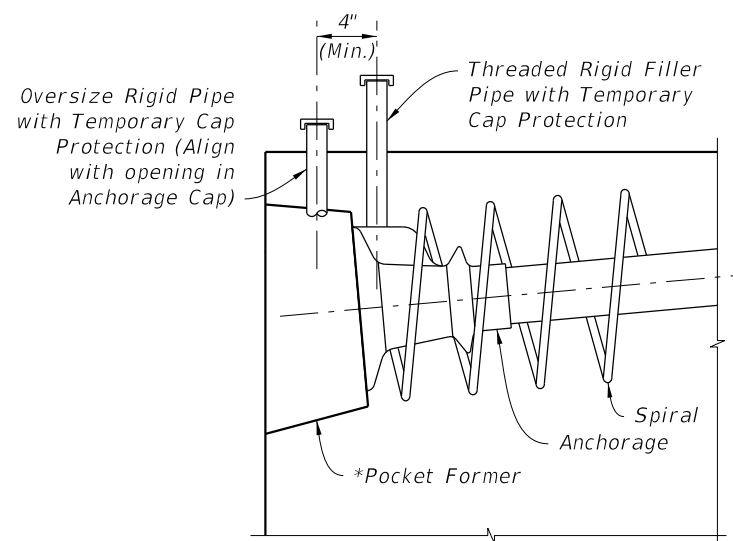

**1 INSTALLATION & SHIPPING**

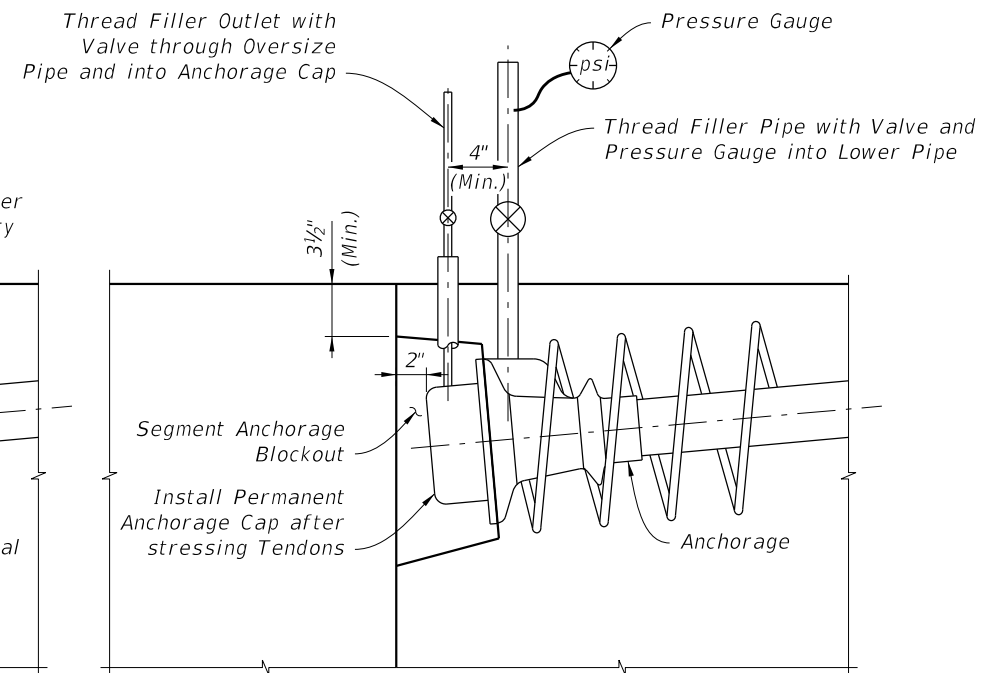

**2 FILLER INJECTION**

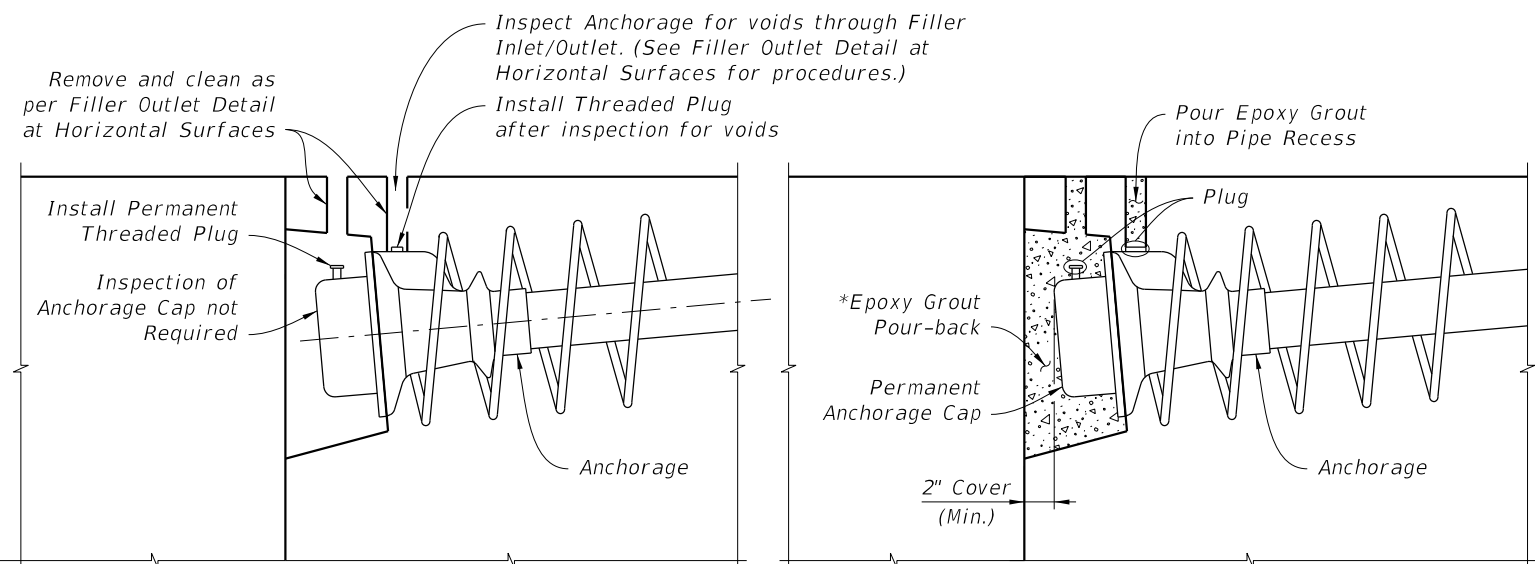

**3 INSPECTION**

**4 PROTECTION**

**TOP INSPECTED ANCHORAGE WITH FILLER INLET INSTALLATION, FILLER INJECTION, INSPECTION & PROTECTION**

**NOTES:**

1. Holes used for the Inspection and Filler Inlets/Outlets may be formed using tapered pipes or mandrels.

- \* Round Pocket Former - Gravity fed placement of epoxy grout acceptable
- Modified Square Pocket Former - Gravity fed placement of epoxy grout acceptable
- Square Pocket Former - Vacuum epoxy grouting required

6/24/2015 7:54:11 AM

LAST REVISION  
07/01/15

REVISION

DESCRIPTION:

**FDOT** 2016 DESIGN STANDARDS

**POST-TENSIONING ANCHORAGE AND TENDON FILLING DETAILS**

INDEX NO.  
21803

SHEET NO.  
1 of 3

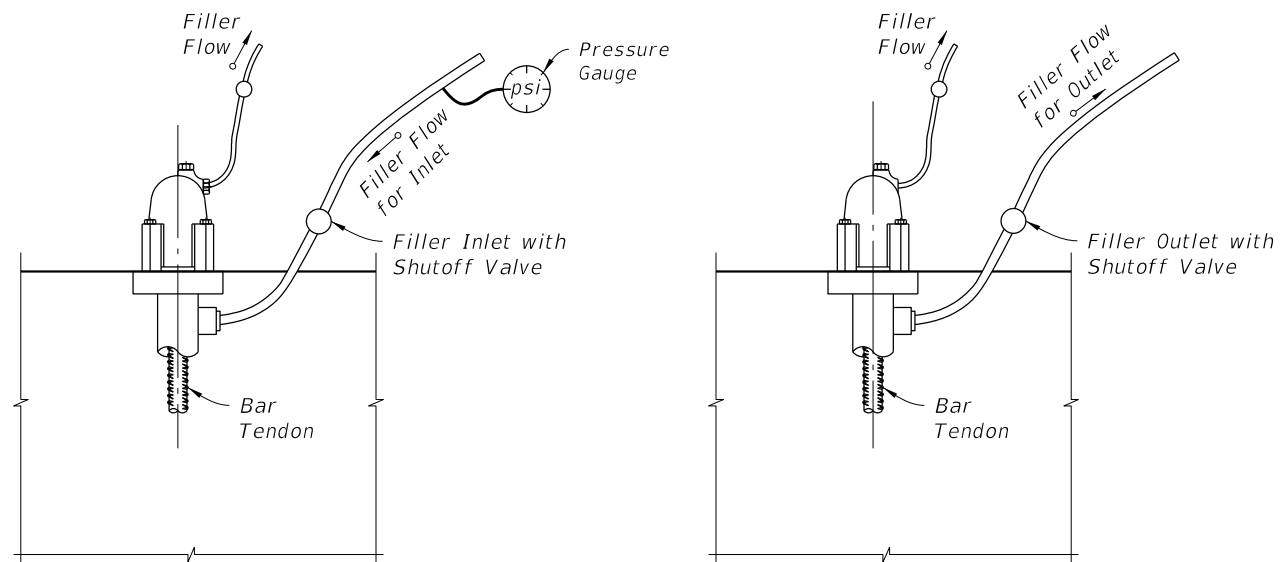

INLET END

OUTLET END

FILLER INLET AND OUTLET DETAILS FOR BAR TENDONS

NOTE:  
Anchor or Nut to allow for flow of Filler into Cap.

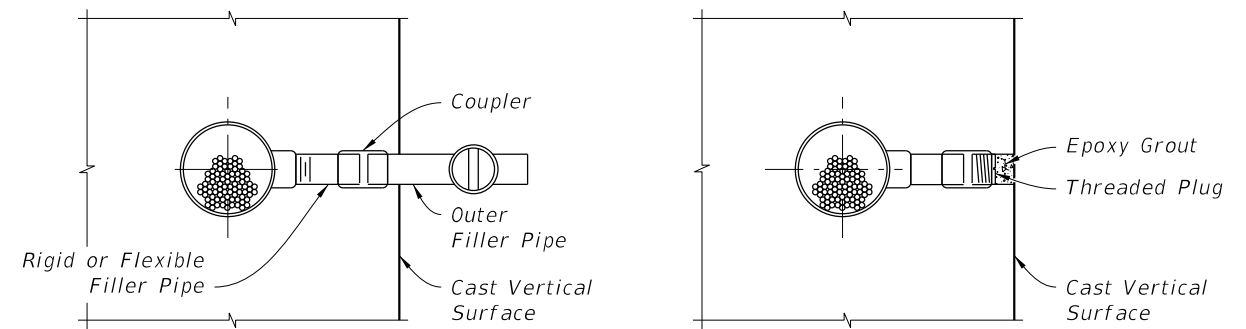

1 FILLER OUTLET CONNECTION TO TENDON

3 FILLING POCKET

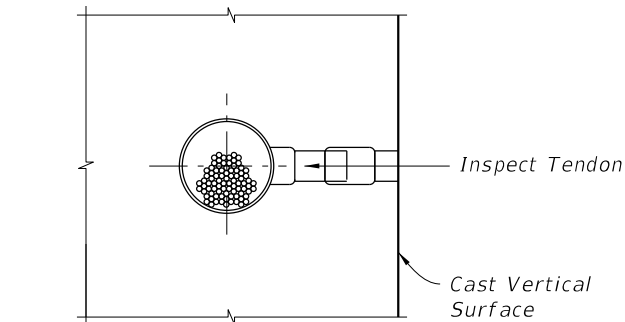

2 POCKET PREPARATION

- PROCEDURE:
1. Remove Rigid Filler Pipe or drill Grout in flexible pipe.
  2. Inspect tendon for voids.
  3. Vacuum inject as required. If grout is used, allow grout to cure. If flexible filler is used, replace filler displaced by inspection. Remove pipe used for vacuum injecting.
  4. Install Threaded Plug into Outlet to form a tight fit.
  5. Over-ream hole ( $\frac{1}{4}$ "  $\varnothing$  over-ream). Clean and roughen sides.
  6. Fill pocket with epoxy grout.

FILLER OUTLET DETAIL AT VERTICAL SURFACES

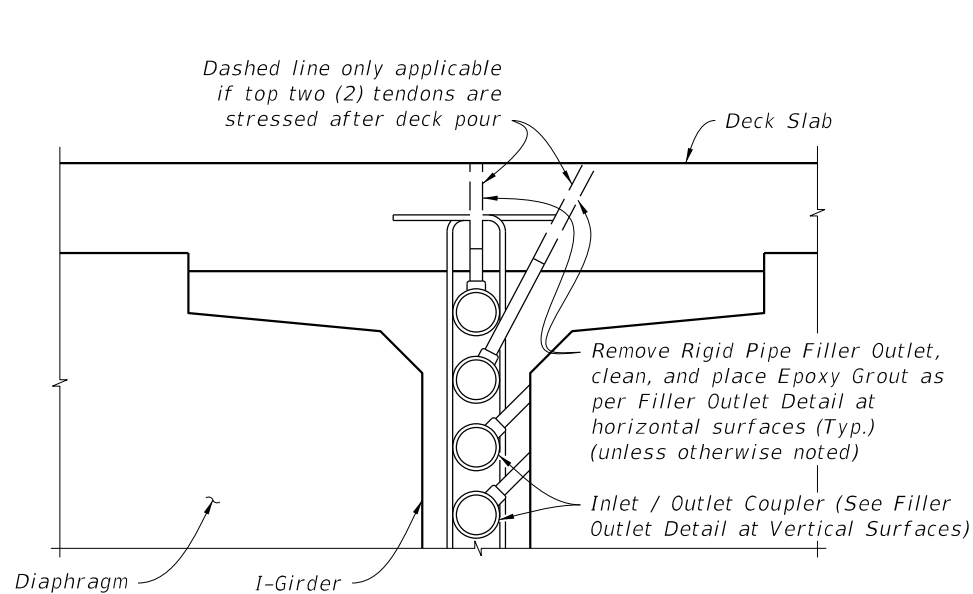

HIGH POINT INSPECTION  
LOCATION AT FILLER OUTLET

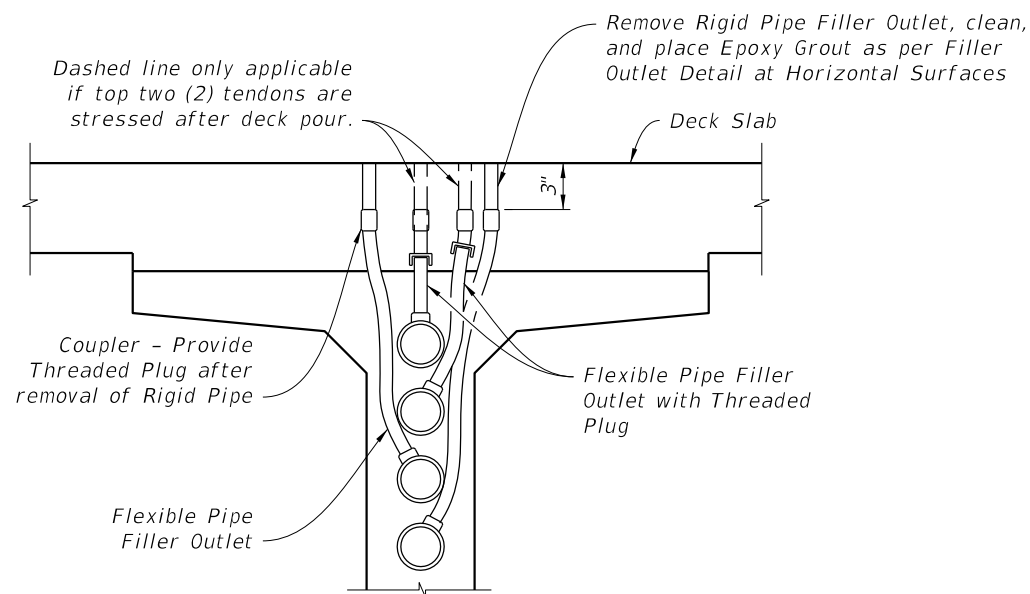

TENDONS AT 3'  
FROM HIGH POINTS (FILLER OUTLET)

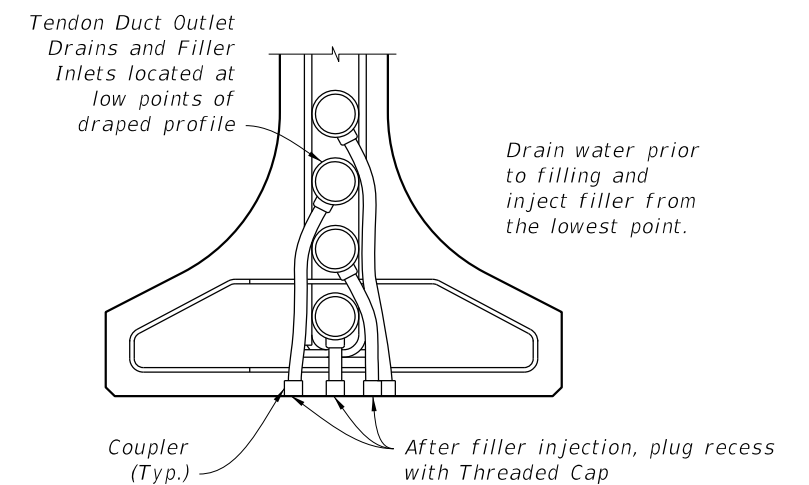

TENDONS AT LOW POINTS  
(FILLER INLET / DRAIN)

FILLER INLET AND OUTLET DETAILS FOR I-GIRDERS

Details for C.I.P. Boxes with Internal Tendons similar. Web reinforcing not shown for clarity.

6/24/2015 7:54:11 AM

LAST REVISION  
07/01/15

REVISION

DESCRIPTION:



2016  
DESIGN STANDARDS

POST-TENSIONING ANCHORAGE  
AND TENDON FILLING DETAILS

INDEX NO.  
21803

SHEET NO.  
2 of 3

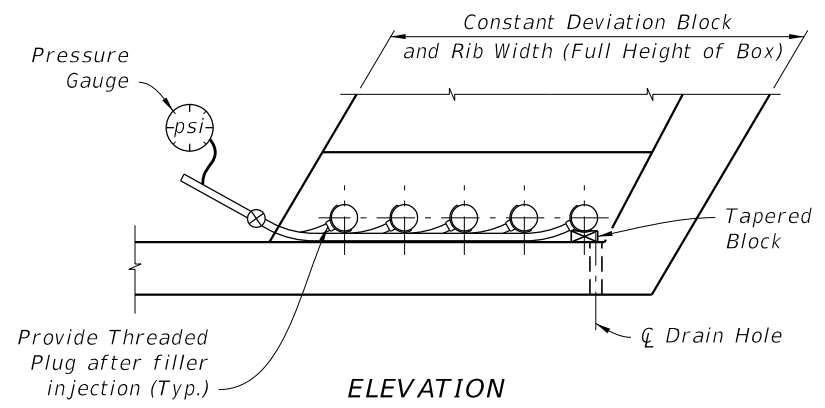

**ELEVATION OF FILLER INLET**

**NOTES:**  
Place tapered blocks under each Tendon to be injected to raise Duct off Tendon Strands. Center Strands within Duct before filling. Blocks shall be removed after filling injection. Blocks shall not damage or permanently deform Duct.

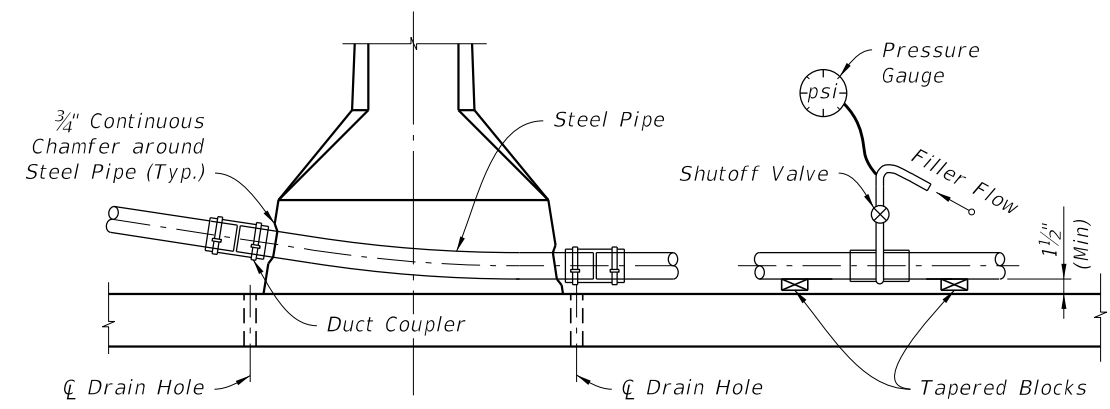

**SECTION**

**TENDON FILLING FOR SPAN BY SPAN CONSTRUCTION**

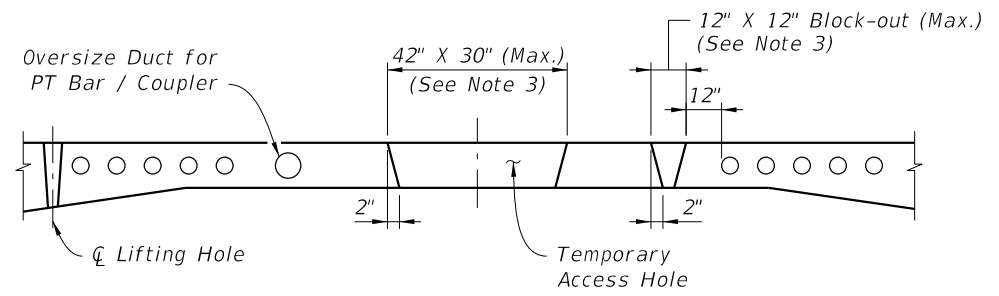

**TEMPORARY ACCESS HOLES**

*Notes: Temporary Access Holes*

1. Temporary access holes to facilitate access for erection, jacking and tendon filling operations inside the box during construction are allowed. The access holes shall be limited to a maximum size of 42" wide x 30" long and shall be limited to one per span.
2. Slab block-outs for temporary / permanent longitudinal post-tensioning bars are not allowed. Temporary / permanent PT bars in the top slab shall be placed in oversized ducts in the slab to accommodate both the bar and coupler.
3. In lieu of 1 ~ 42" x 30" temporary access hole, a maximum of 2 top slab block-outs (12" x 12" (Max.)) between the webs is allowed for construction per span. Block-outs shall be a minimum of 12" from the nearest duct or anchor and shall be located as to prevent direct drip onto bottom slab anchors.

*Notes: Repair of Temporary Access Holes, Block-outs, and Lifting Holes*

1. Form all large block-outs with tapered sides.
2. Immediately before casting the concrete, mechanically clean the mating concrete surfaces to remove any laitance and to expose small aggregate.
3. Repair all holes and block-outs with Magnesium Ammonium Phosphate Concrete within 24 hours of cleaning concrete.
4. After completion of the deck planing and grooving, coat the repaired and surrounding concrete surfaces with High Molecular Weight Methacrylate.
5. Alternately, epoxy grout may be used to repair holes. High Molecular Weight Methacrylate is not required with epoxy grout.

6/24/2015 7:54:12 AM

LAST REVISION	07/01/15	DESCRIPTION:
---------------	----------	--------------



**POST-TENSIONING ANCHORAGE AND TENDON FILLING DETAILS**

INDEX NO.	21803	SHEET NO.	3 of 3
-----------	-------	-----------	--------