

PLAN VIEW OF ACCESS HATCH ASSEMBLY

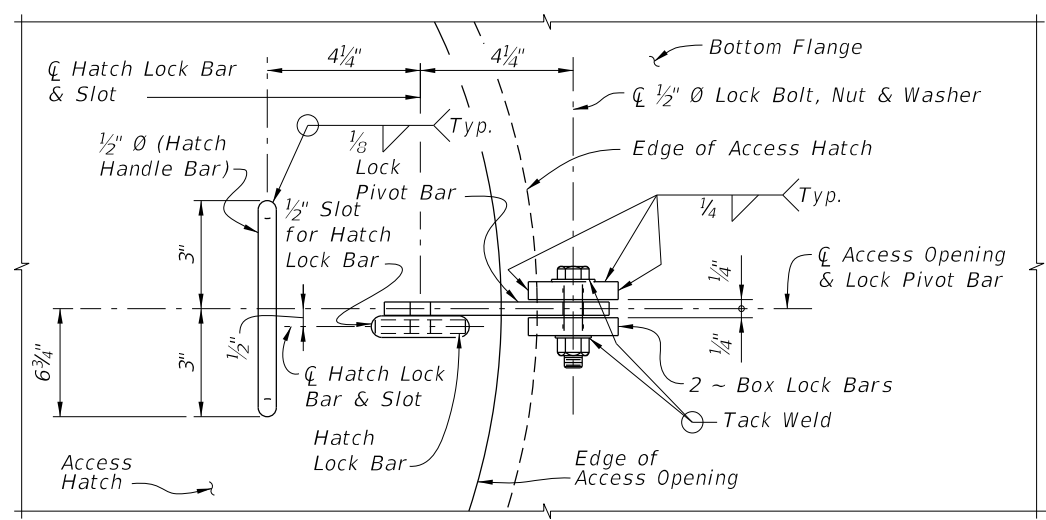

VIEW A-A

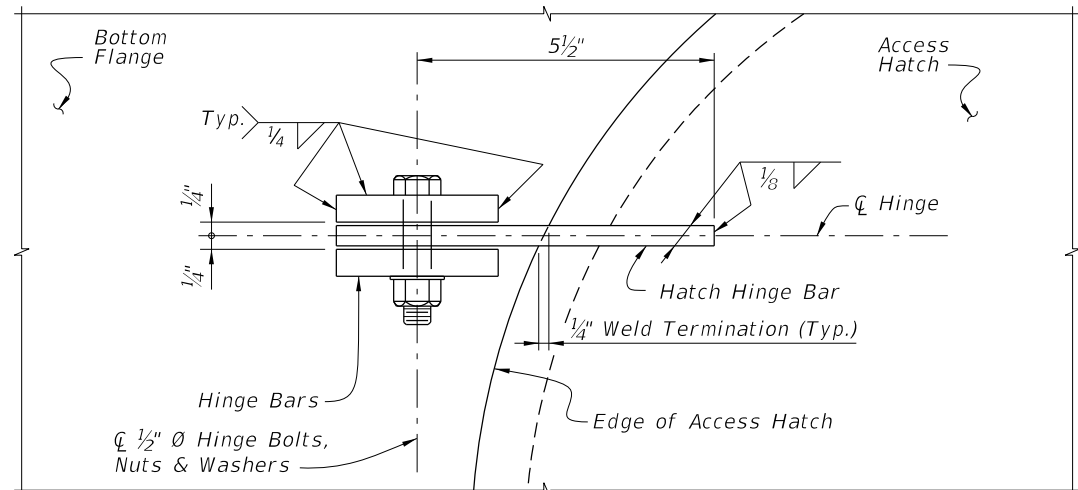

HINGE DETAIL

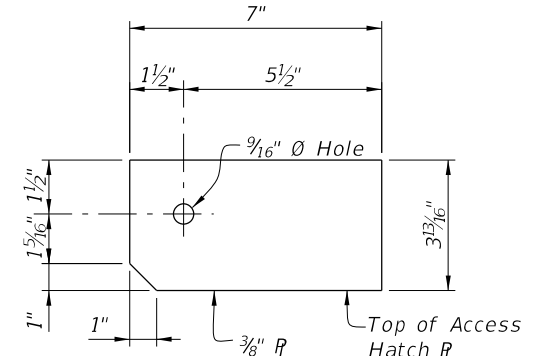

HATCH HINGE BAR DETAIL

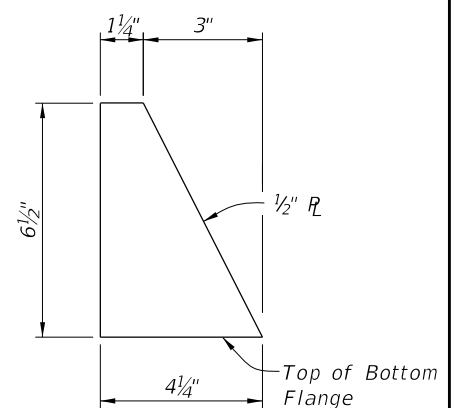

STOP BAR DETAIL

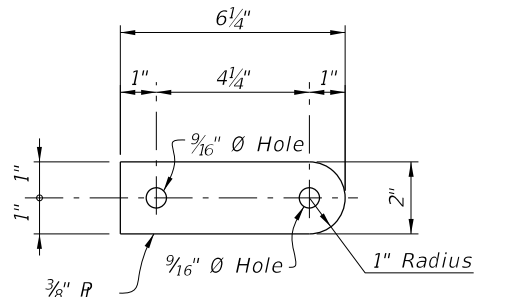

LOCK PIVOT BAR DETAIL

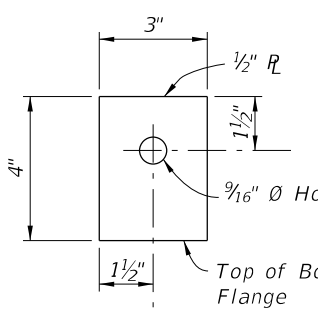

HINGE BAR DETAIL

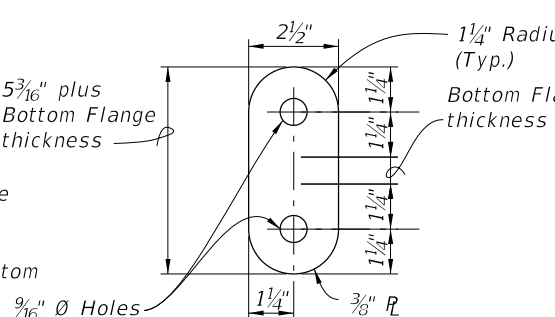

HATCH LOCK BAR DETAIL

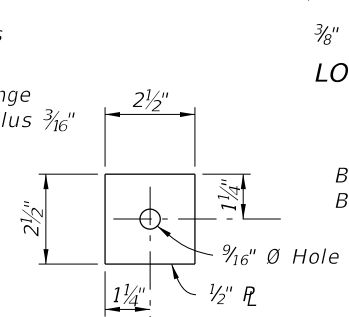

BOX LOCK BAR DETAIL

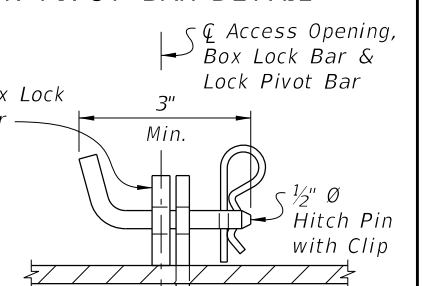

VIEW B-B HATCH LOCK ASSEMBLY DETAIL

HINGE NOTE:
Orient the Access Hatch so that the hinges are located down-grade.

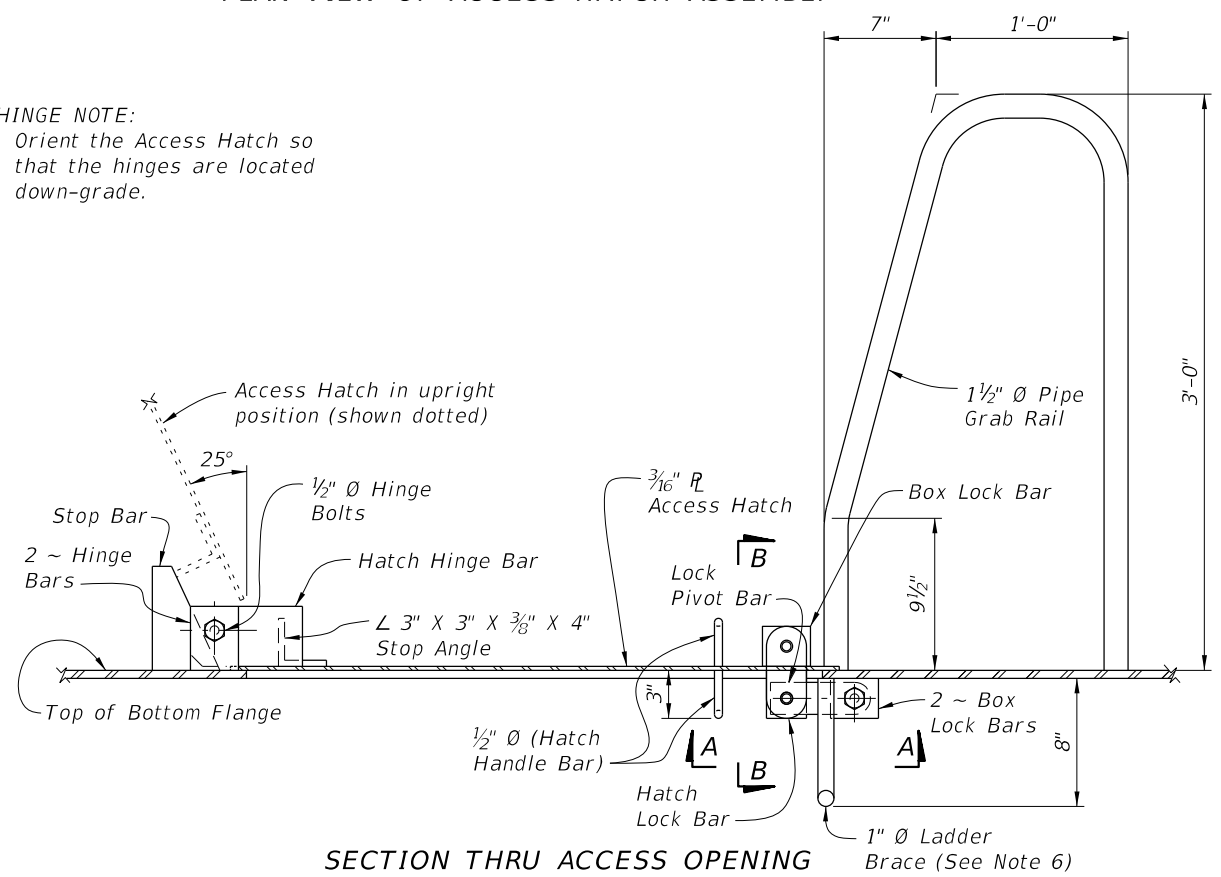

SECTION THRU ACCESS OPENING

- NOTES:
1. All Structural Steel material in Access Hatch Assemblies shall conform to ASTM A709 Grade 36.
 2. 1 1/2\"/>

6/30/2015 10:19:17 AM

LAST REVISION 07/01/15	DESCRIPTION:	2016 DESIGN STANDARDS	ACCESS HATCH ASSEMBLY FOR STEEL BOX SECTIONS	INDEX NO. 21250	SHEET NO. 1 of 1
---------------------------	--------------	------------------------------	---	---------------------------	----------------------------