

PLAN VIEW (CASE 1)

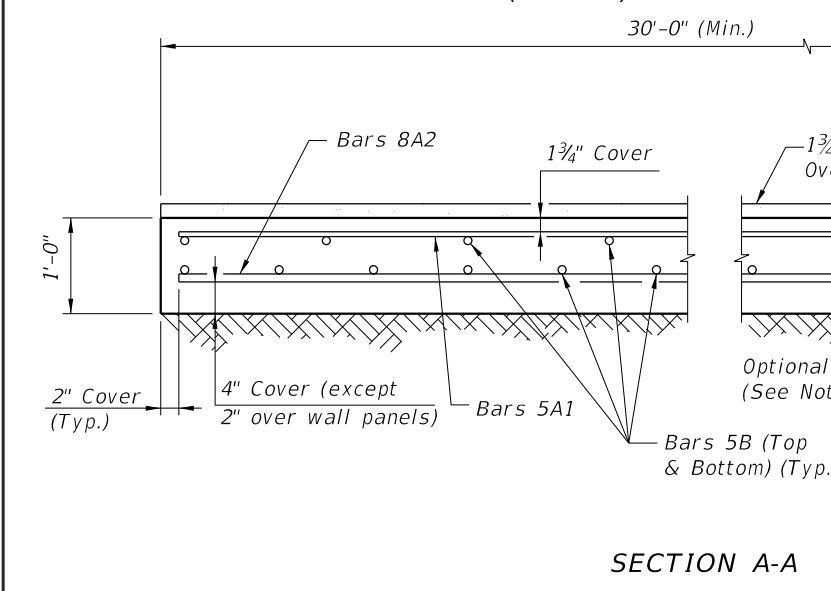

SECTION A-A

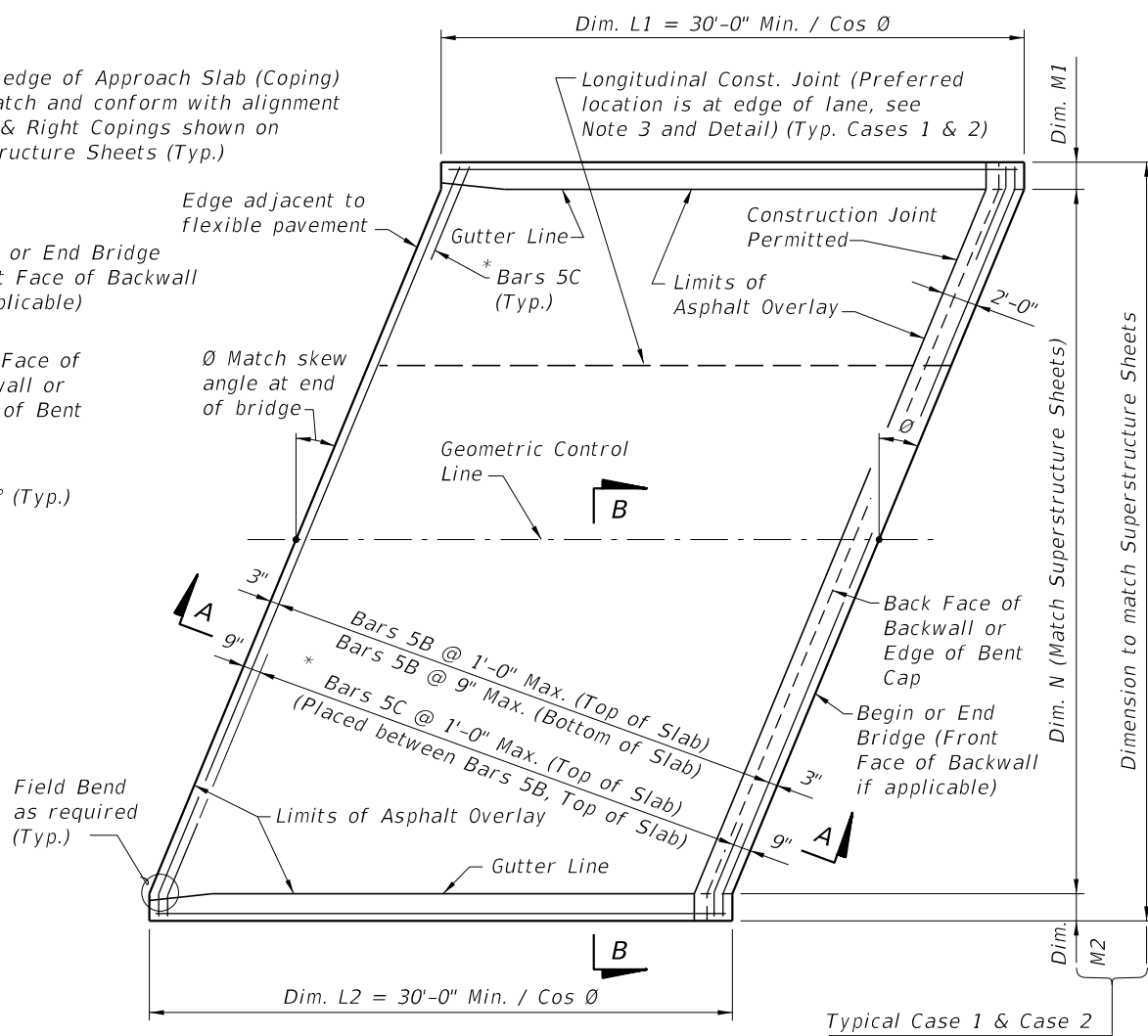

PLAN VIEW (CASE 2)

* NOTE: Bars 5C are required as shown when either the 32" or 42" F-Shape Traffic Railings or the Traffic Railing/Noise Wall are used at the edge of the Approach Slab.

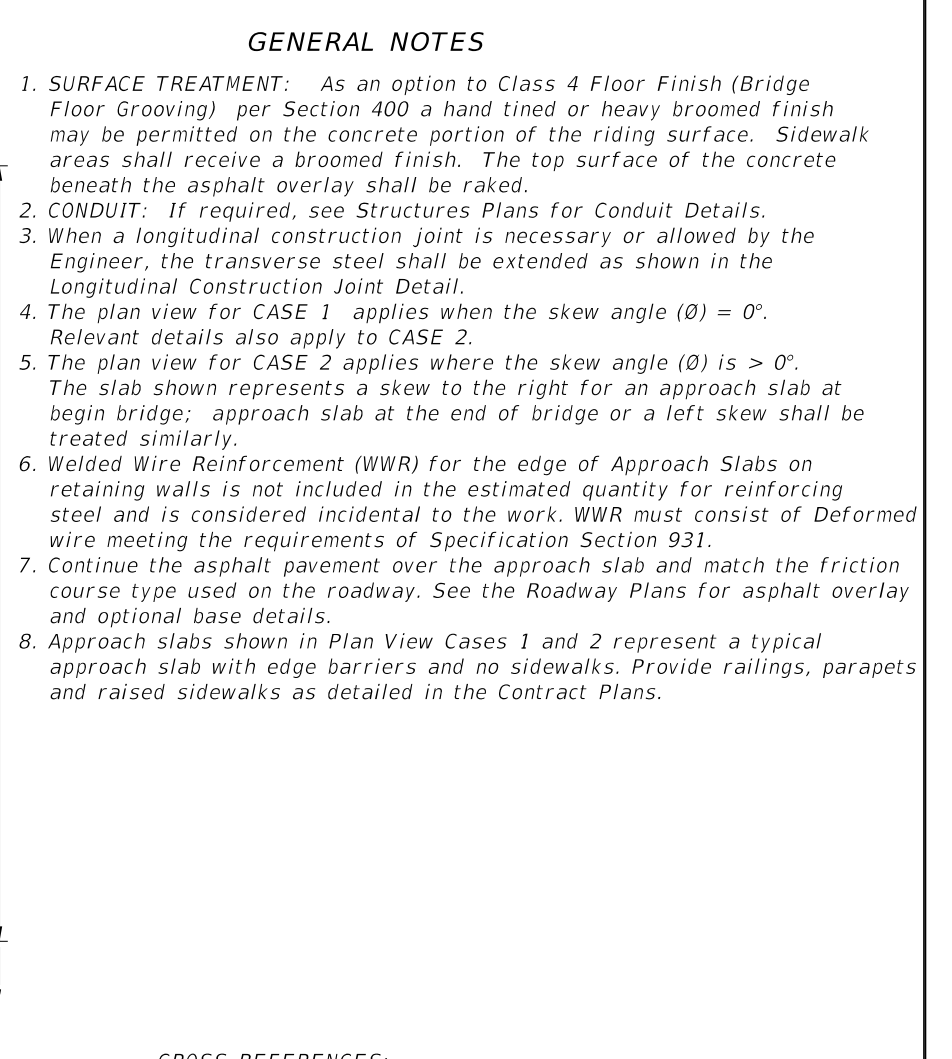

CROSS REFERENCES:

For Section B-B, Longitudinal Construction Joint Detail and Approach Slab Details see Sheet 2.

6/24/2015 7:22:43 AM

LAST REVISION 07/01/14	REVISION	DESCRIPTION:	 2016 DESIGN STANDARDS	APPROACH SLABS (FLEXIBLE PAVEMENT APPROACHES)	INDEX NO. 20900	SHEET NO. 1 of 2
---------------------------	----------	--------------	------------------------------	--	--------------------	---------------------

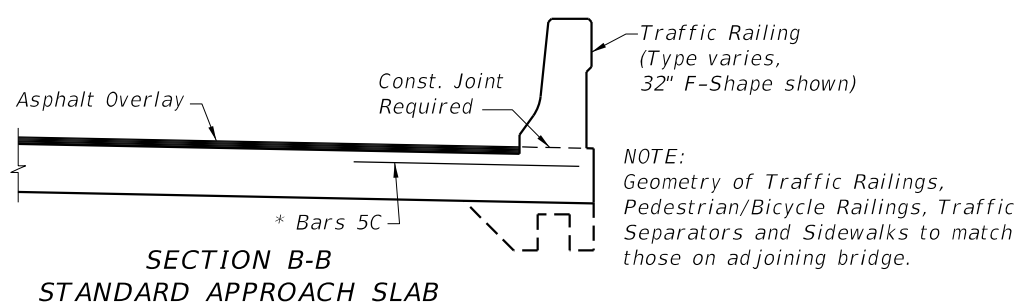

**SECTION B-B
STANDARD APPROACH SLAB**

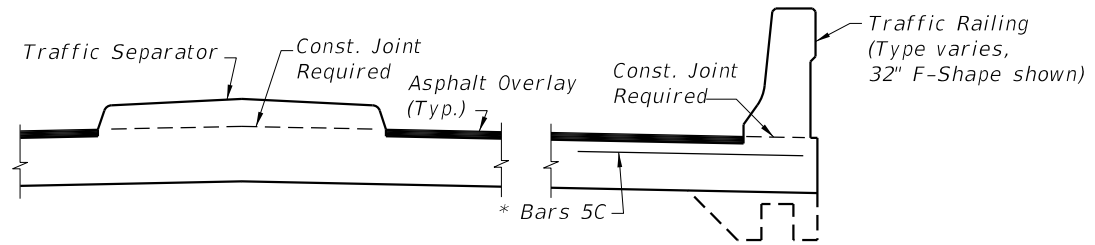

**SECTION B-B
APPROACH SLAB WITH TRAFFIC SEPARATOR**

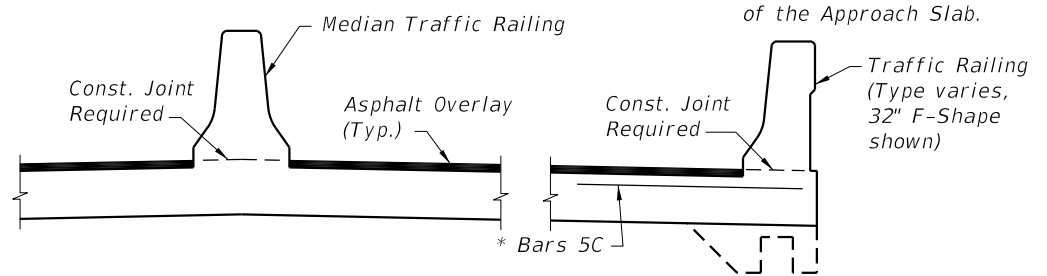

**SECTION B-B
APPROACH SLAB WITH MEDIAN TRAFFIC RAILING**

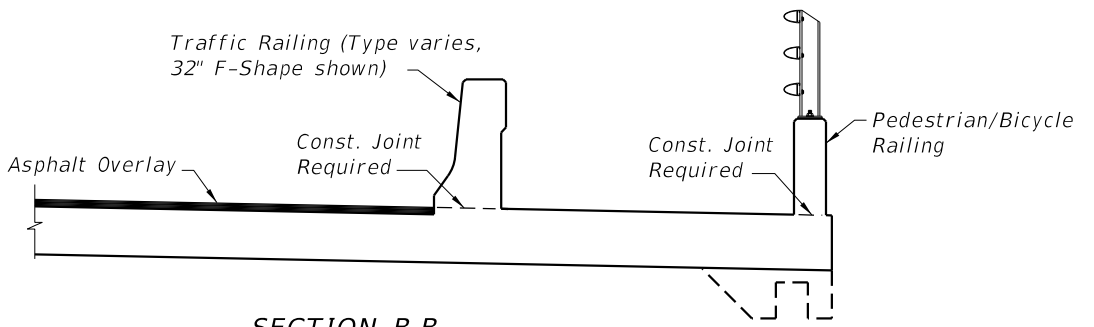

**SECTION B-B
APPROACH SLAB WITH SIDEWALK**

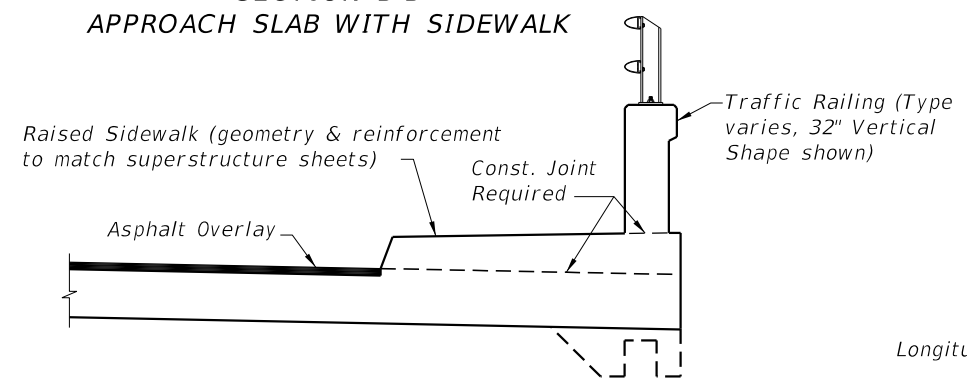

**SECTION B-B
APPROACH SLAB WITH RAISED SIDEWALK**

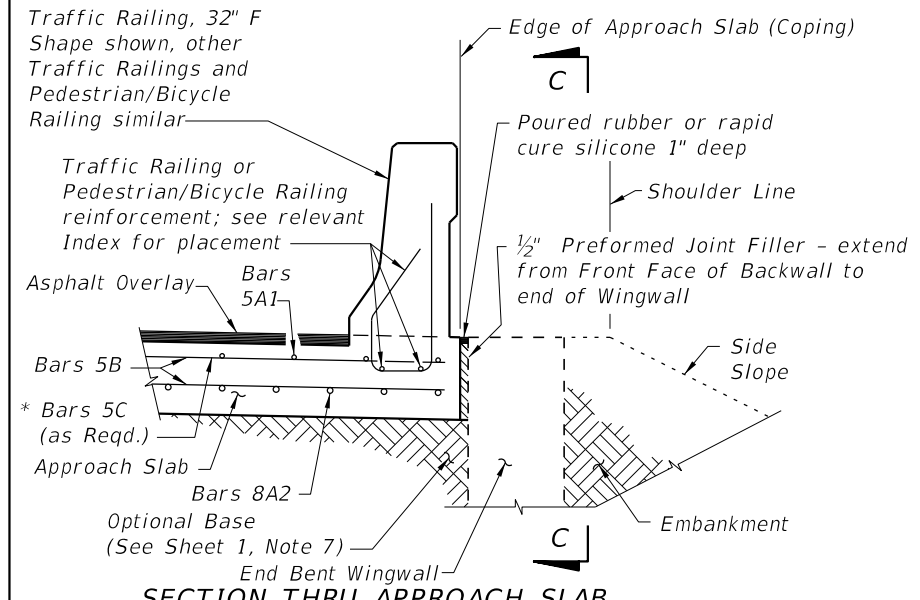

**SECTION THRU APPROACH SLAB
AND END BENT WINGWALL**

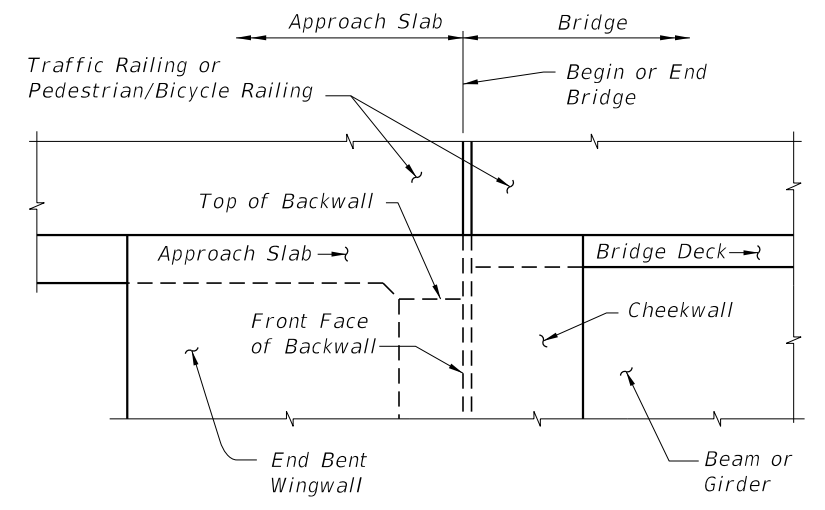

**VIEW C-C AT BEGIN OR END BRIDGE (BEAM
BRIDGE SHOWN, FLAT SLAB BRIDGE SIMILAR)**

APPROACH SLAB WITH WINGWALL DETAILS

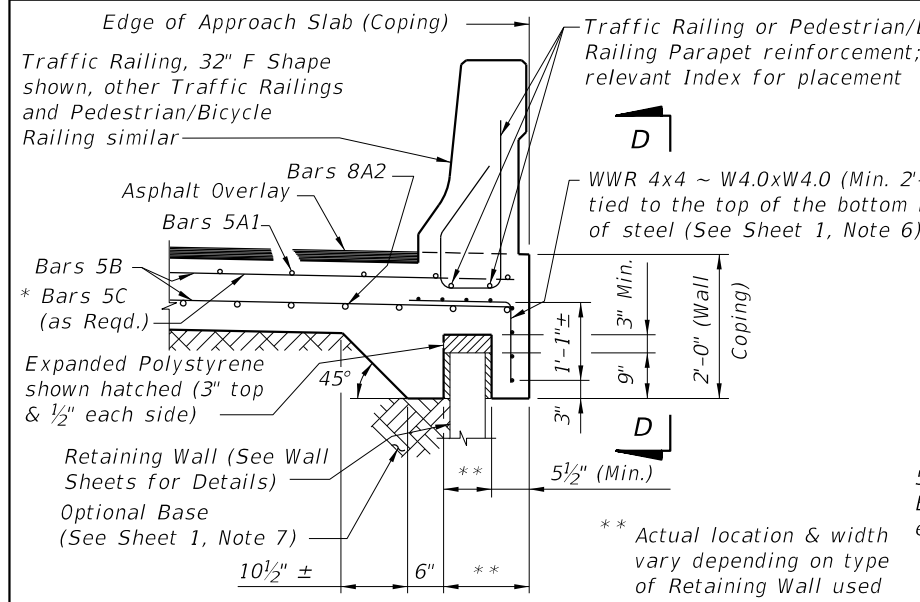

**SECTION THRU APPROACH SLAB
AND RETAINING WALL**

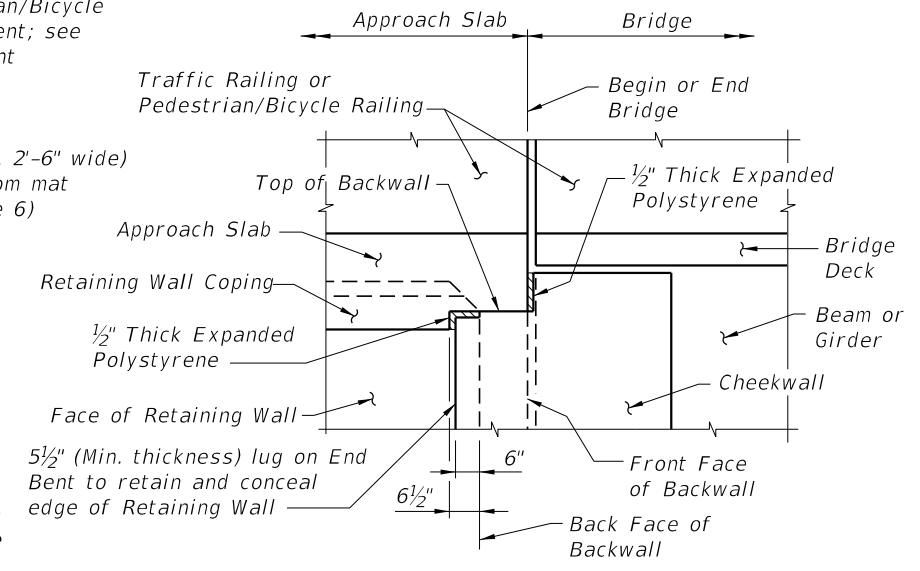

**VIEW D-D AT BEGIN OR END BRIDGE (BEAM
BRIDGE SHOWN, FLAT SLAB BRIDGE SIMILAR)**

APPROACH SLAB WITH RETAINING WALL DETAILS

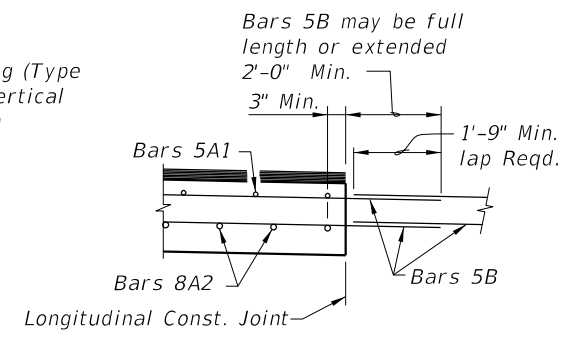

**LONGITUDINAL CONSTRUCTION
JOINT DETAIL**

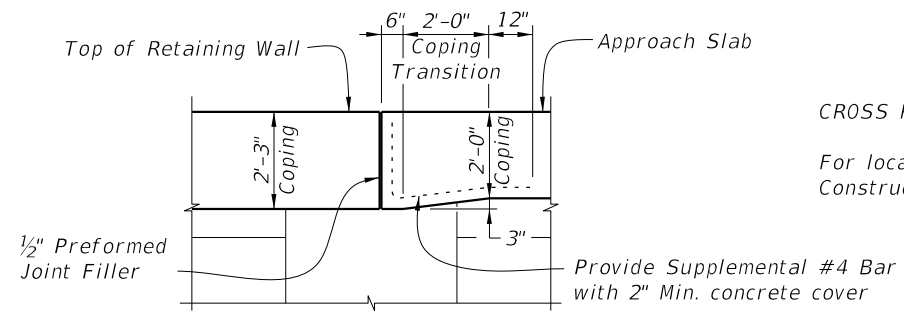

**COPING TRANSITION DETAIL FOR
RETAINING WALLS WITH 2'-3\"/>**

CROSS REFERENCES:
For location of Section B-B and Longitudinal Construction Joint see Sheet 1.

6/24/2015 7:22:44 AM

LAST REVISION 07/01/14	REVISION	DESCRIPTION:	 2016 DESIGN STANDARDS	APPROACH SLABS (FLEXIBLE PAVEMENT APPROACHES)	INDEX NO. 20900	SHEET NO. 2 of 2
---------------------------	----------	--------------	--------------------------------------	--	---------------------------	----------------------------