

TYPICAL INSTALLATIONS FOR SIGN PANEL(S) MOUNTED ON SPAN WIRE

- Notes:
1. Bottom edge of signs shall be approximately at the same elevation.
 2. Type B & C attachments with one hanger shall have wind beams for signs wider than 3½'. The beams shall extend to within 6" of the sign edge.
 3. Type B & C attachments for signs 4' and wider shall have 2 hangers. Signs 7' and wider shall have wind beams that extend to within 6" of the sign edge.
 4. Type D attachments shall be for signs 3½' wide or less.
 5. Sign panels shall meet the requirements of Index 11200.
 6. Refer to section 634 of the Standard Specifications For Road And Bridge Construction.
 7. All bolts, nuts, and washers shall be passivated stainless steel, AISI 300 series, commercial grade, type 316.

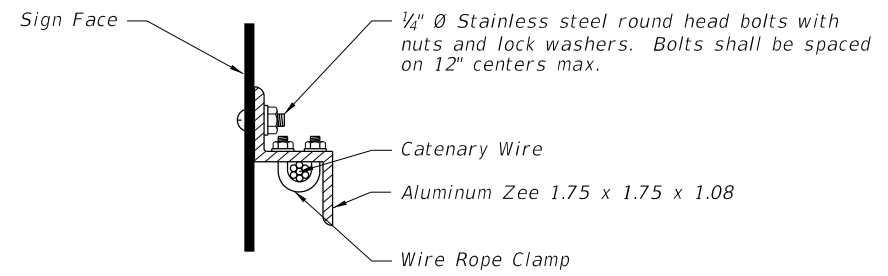

SIGN MOUNTING DETAIL

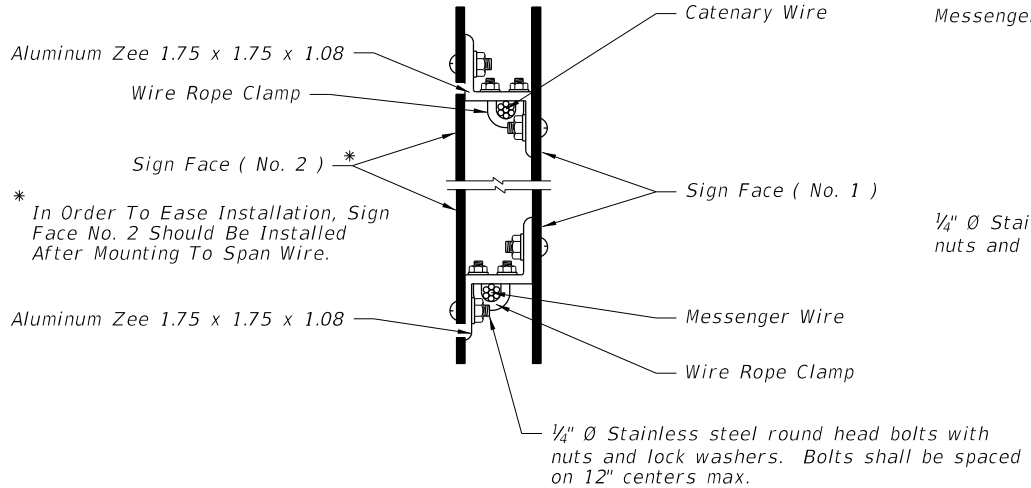

DETAIL OF OPPOSING SIGNS SPAN WIRE MOUNTED

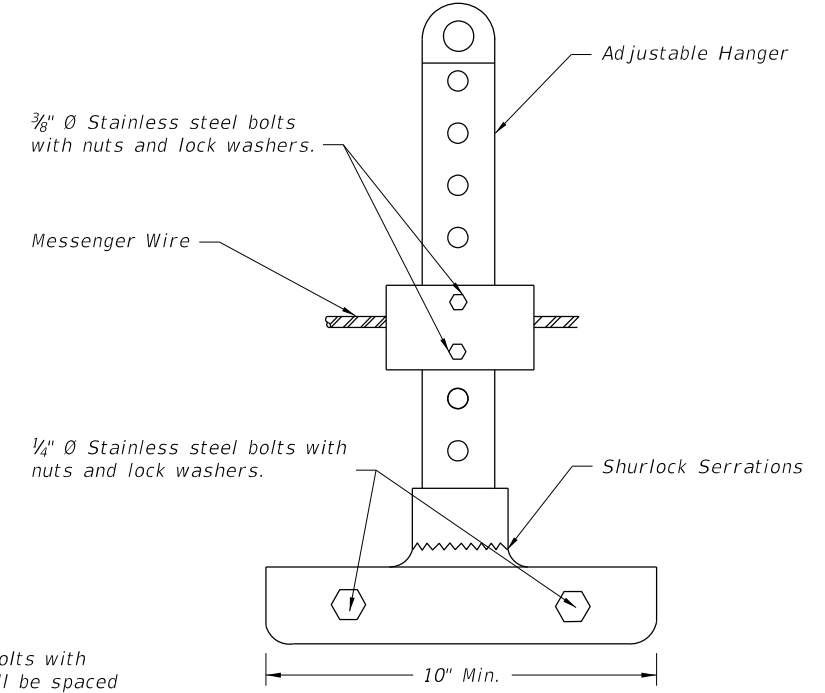

ADJUSTABLE HANGER FOR SIGN MOUNTING

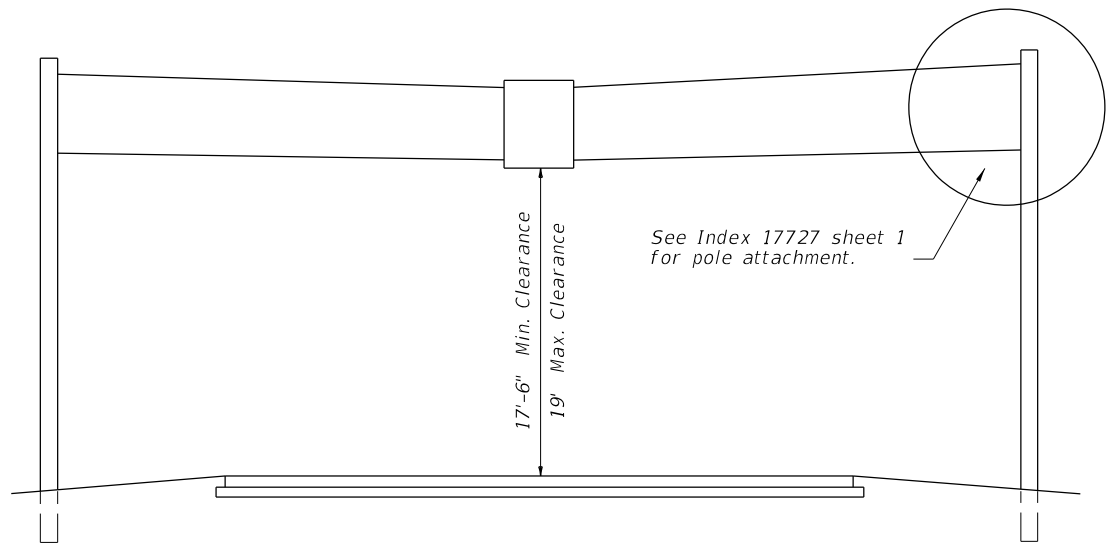

TYPICAL SPAN WIRE INSTALLATION

The overlapped connection of adjustable hangers shall use a minimum of 2 bolts with a minimum spacing between bolts of 2".

6/9/2015 4:49:41 PM

TWO POINT ATTACHMENT

LAST REVISION 07/01/09	REVISION	DESCRIPTION:	 2016 DESIGN STANDARDS	SPAN WIRE MOUNTED SIGN DETAILS	INDEX NO. 17356	SHEET NO. 1 of 1
---------------------------	----------	--------------	------------------------------	--------------------------------	--------------------	---------------------