

SOLAR POWERED BEACON

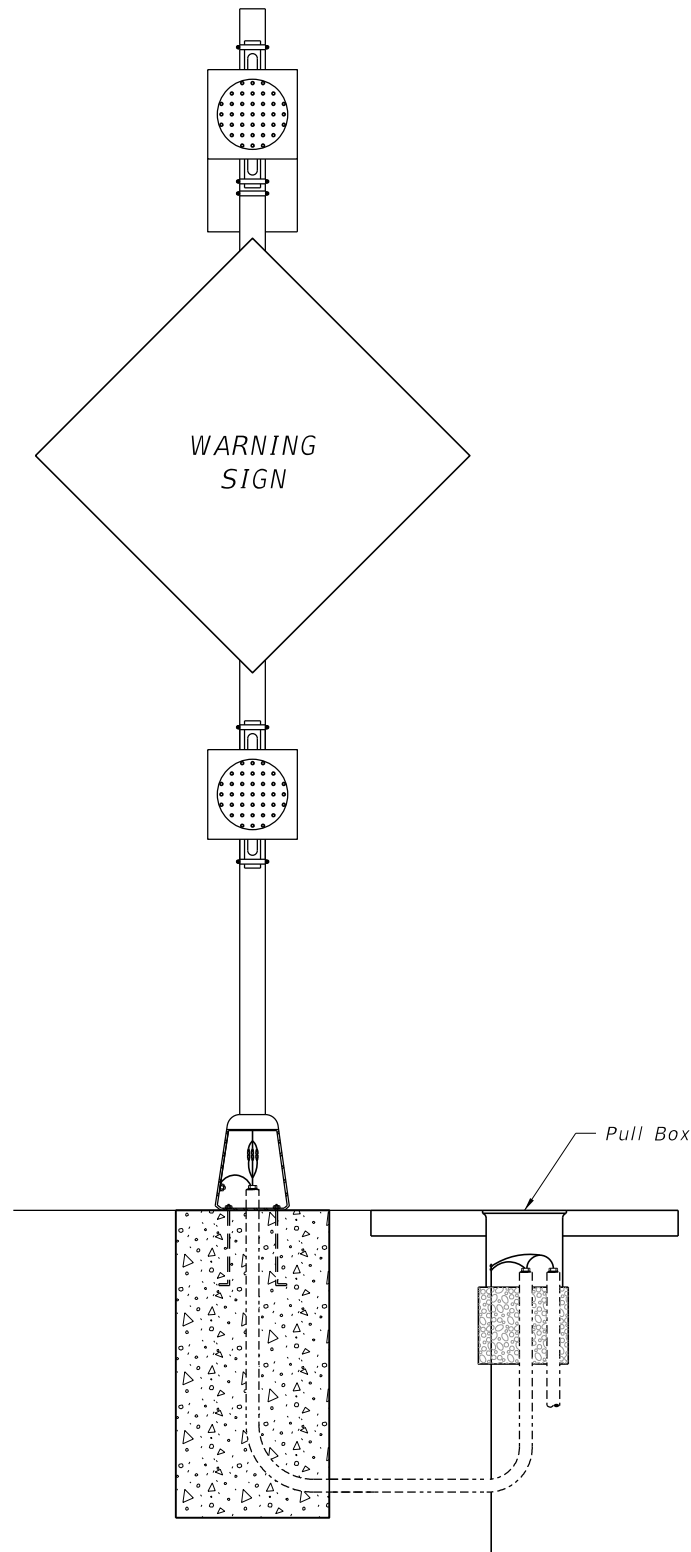

CONVENTIONAL POWERED BEACON

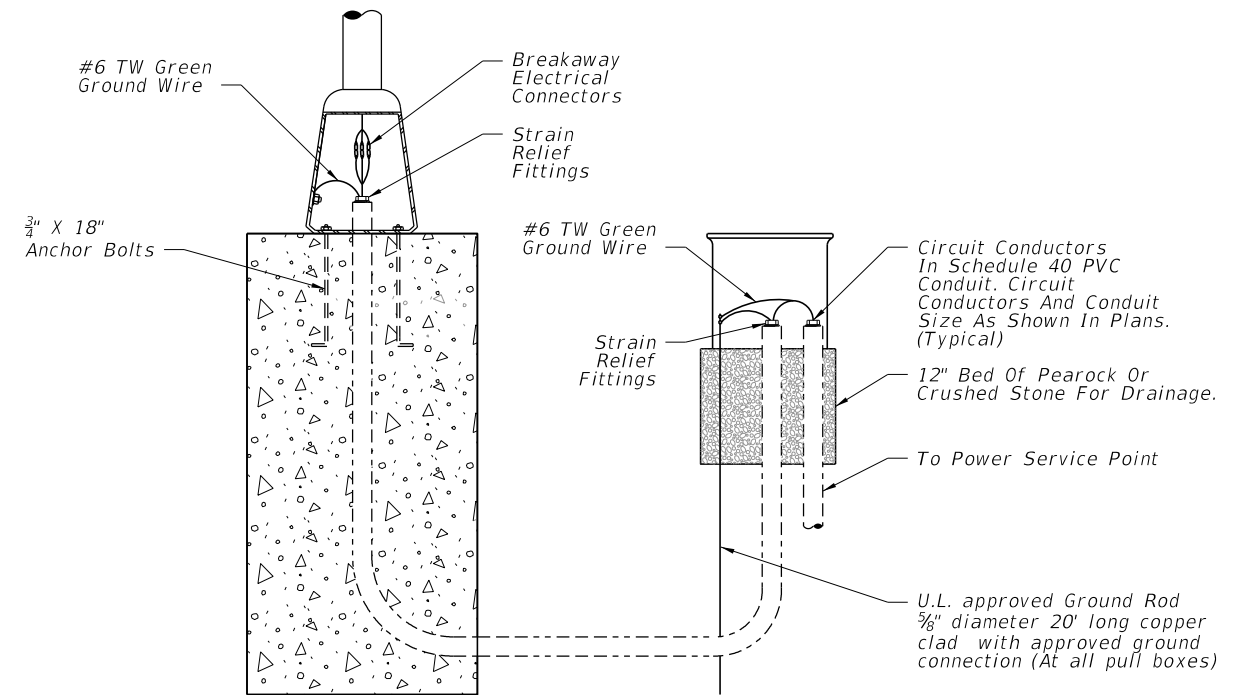

POLE WIRING DETAIL
CONVENTIONAL POWERED BEACON

GENERAL NOTES

1. ALUMINUM: Aluminum materials shall meet the requirements of Aluminum Association Alloy 6061-T6 (ASTM B209, B221, B308 or B429), except as noted.
2. Sign panel, wind beam and columns shall be installed in accordance with Index 11860 and Section 700 of the Specifications.
3. Height and offset to sign column shall be in accordance with Index 17302.
4. When aluminum column (posts) are installed with a frangible pedestal pole bases, engage all threads on the pedestal pole base and pipe unless the pipe is fully seated into base.
5. Aluminum poles and transformer bases shall meet the requirements of Section 646 of the Specifications.
6. A concrete slab shall be installed around all flashing beacon assemblies installed on slopes 6:1 or greater. Minimum dimension of slab shall be 4'-0" by 5'-0".
7. A concrete slab shall be installed around all pull boxes. Minimum dimension of slab shall be 4'-0" by 4'-0". In urban areas where space is limited slab dimensions may be adjusted as shown in the plans.
8. For beacon assemblies connected to conventional power, provide single pole non-fused watertight breakaway electrical connectors in the frangible pedestal pole base.
9. Connection of controller cabinet and solar panel to the column shall be in accordance with manufacturer's recommendations.
10. Holes drilled in sign column for wire entry shall use a bushing or rubber grommet to protect conductors.
11. Orient solar panel to face South for optimal exposure to sunlight.

6/30/2015 9:25:41 AM

LAST REVISION 12/15/14	REVISION	DESCRIPTION:	 2016 DESIGN STANDARDS	ROADSIDE FLASHING BEACON ASSEMBLY	INDEX NO. 11862	SHEET NO. 1 of 7
---------------------------	----------	--------------	---	-----------------------------------	--------------------	---------------------

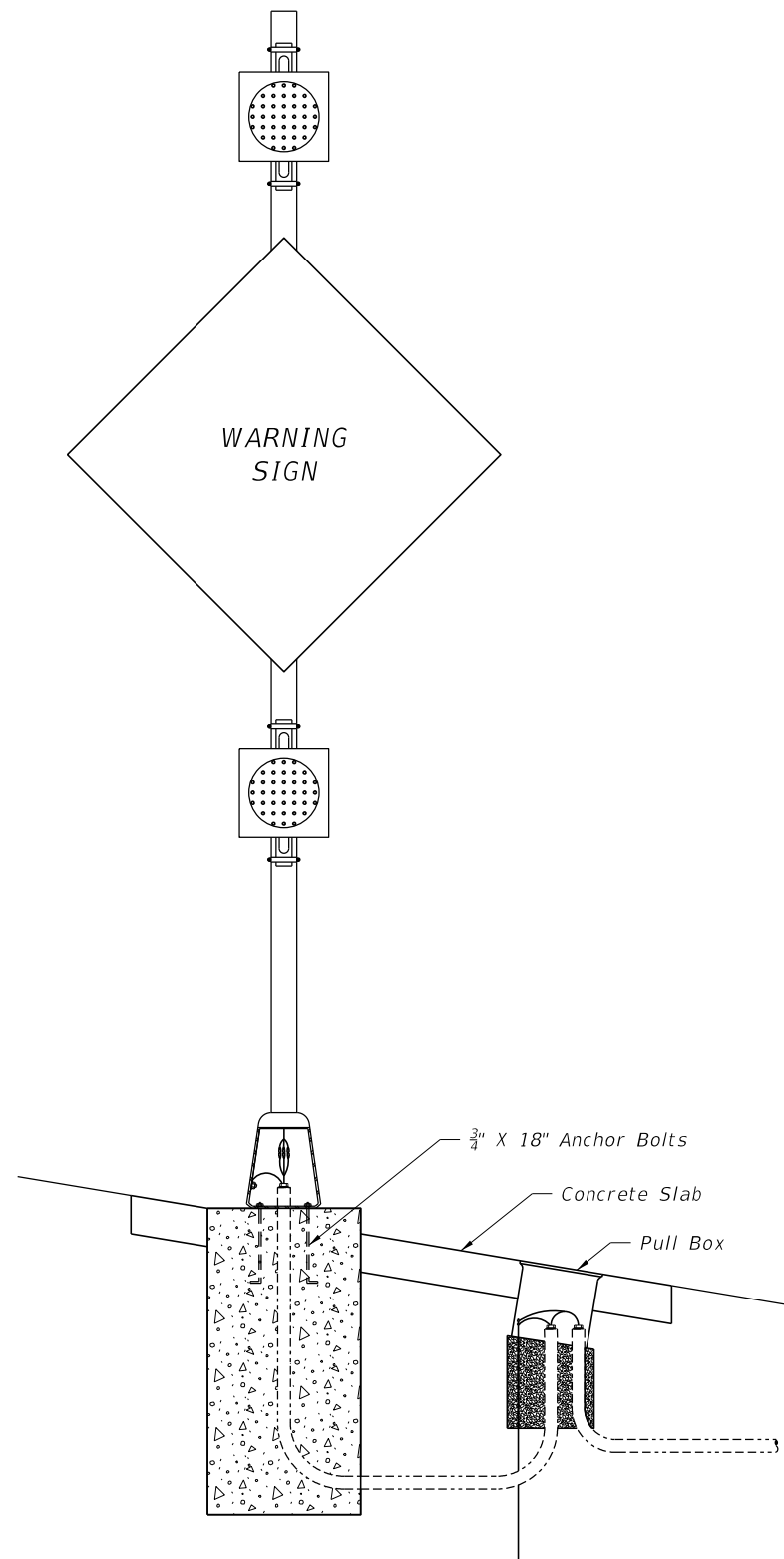

SOLAR POWERED BEACON WITH AUXILLIARY POLE FOR SOLAR PANEL, CONTROLLER AND BATTERIES

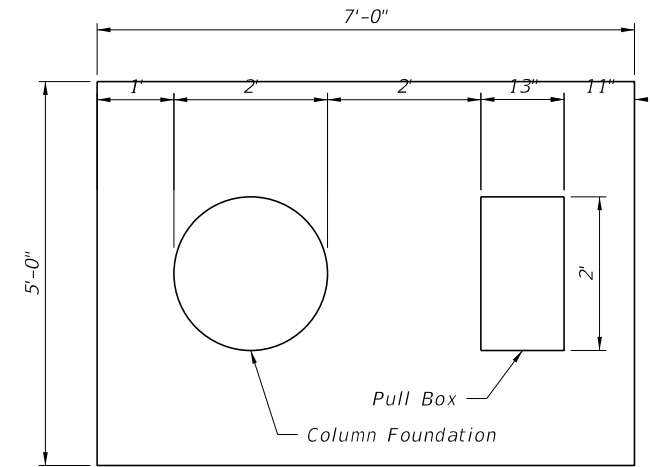
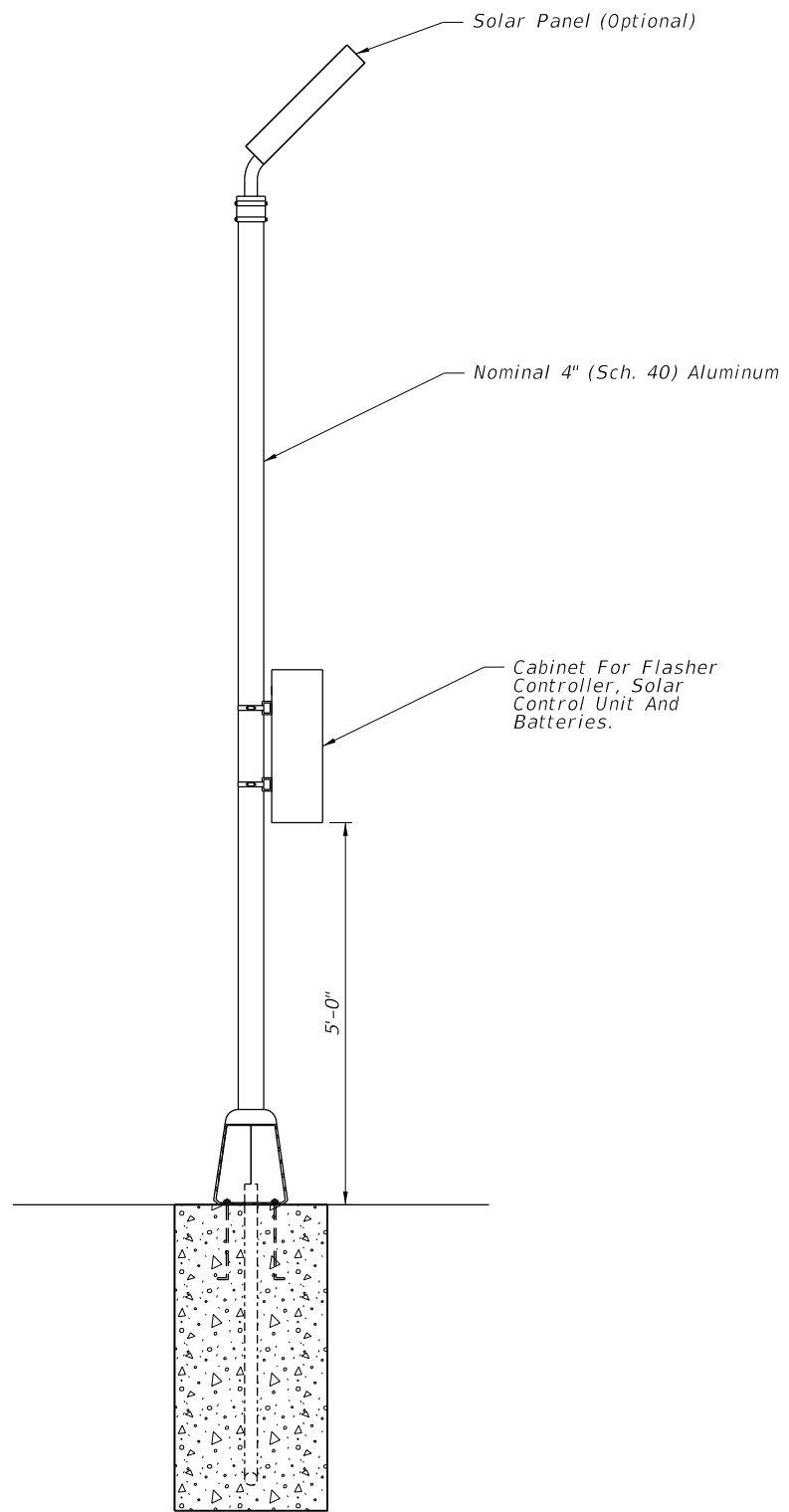

CONCRETE SLAB DETAIL

NOTES

1. All flashing beacon assemblies with solar panels, controllers and batteries weighing more than 170 lbs. shall utilize a separate pole for mounting the solar panel, controller and batteries.
2. The auxillary pole shall be installed outside the recoverable terrain distance and as near the right of way as possible. The recoverable terrain distance shall comply with Design Standard Index 700.
3. Auxilliary pole shall be the same length as the column for the beacon assembly.
3. Payment for the separate pole, foundation, conduit and wiring shall be included in the cost of the electronic warning sign with flashing beacon.

6/30/2015 9:25:41 AM

LAST REVISION 07/01/15	REVISION	DESCRIPTION:	 2016 DESIGN STANDARDS	ROADSIDE FLASHING BEACON ASSEMBLY	INDEX NO. 11862	SHEET NO. 2 of 7
---------------------------	----------	--------------	--	--	---------------------------	----------------------------

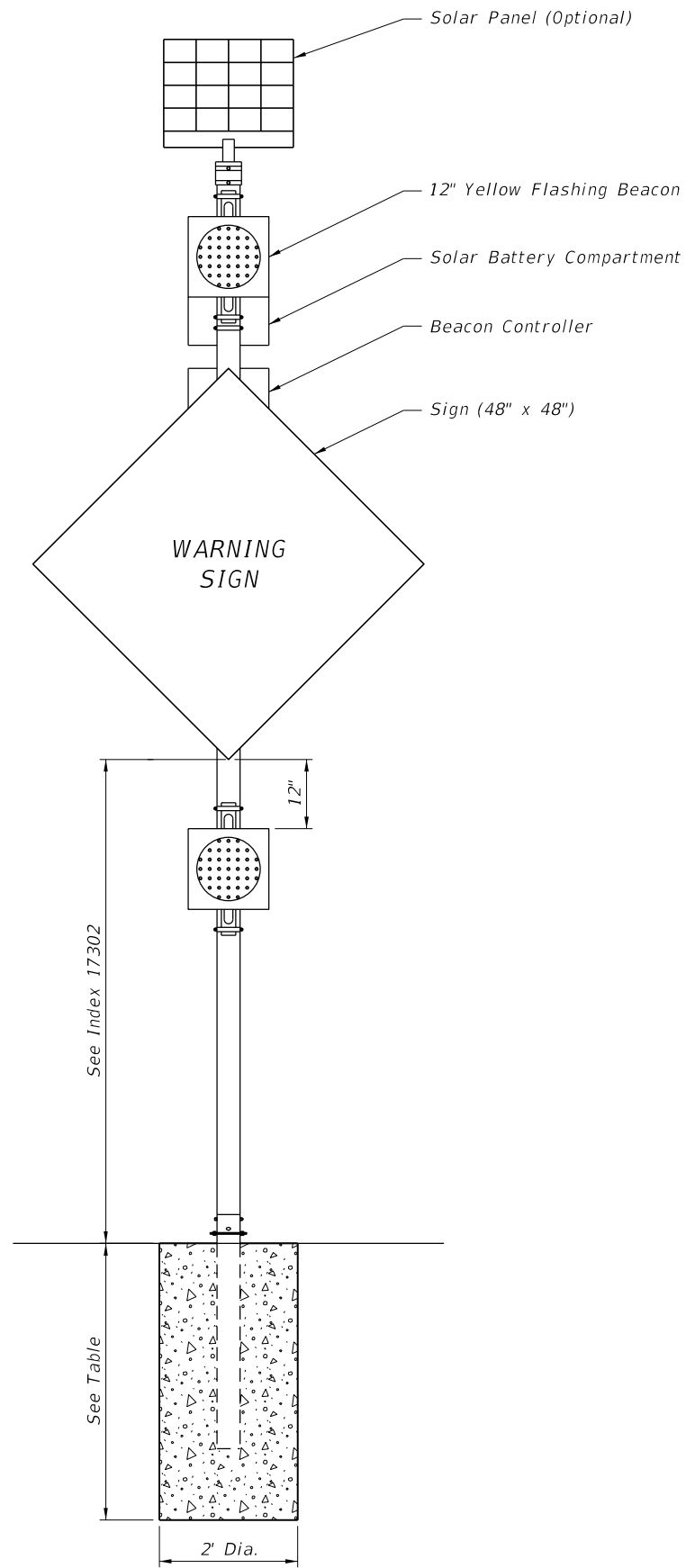

FRONT VIEW

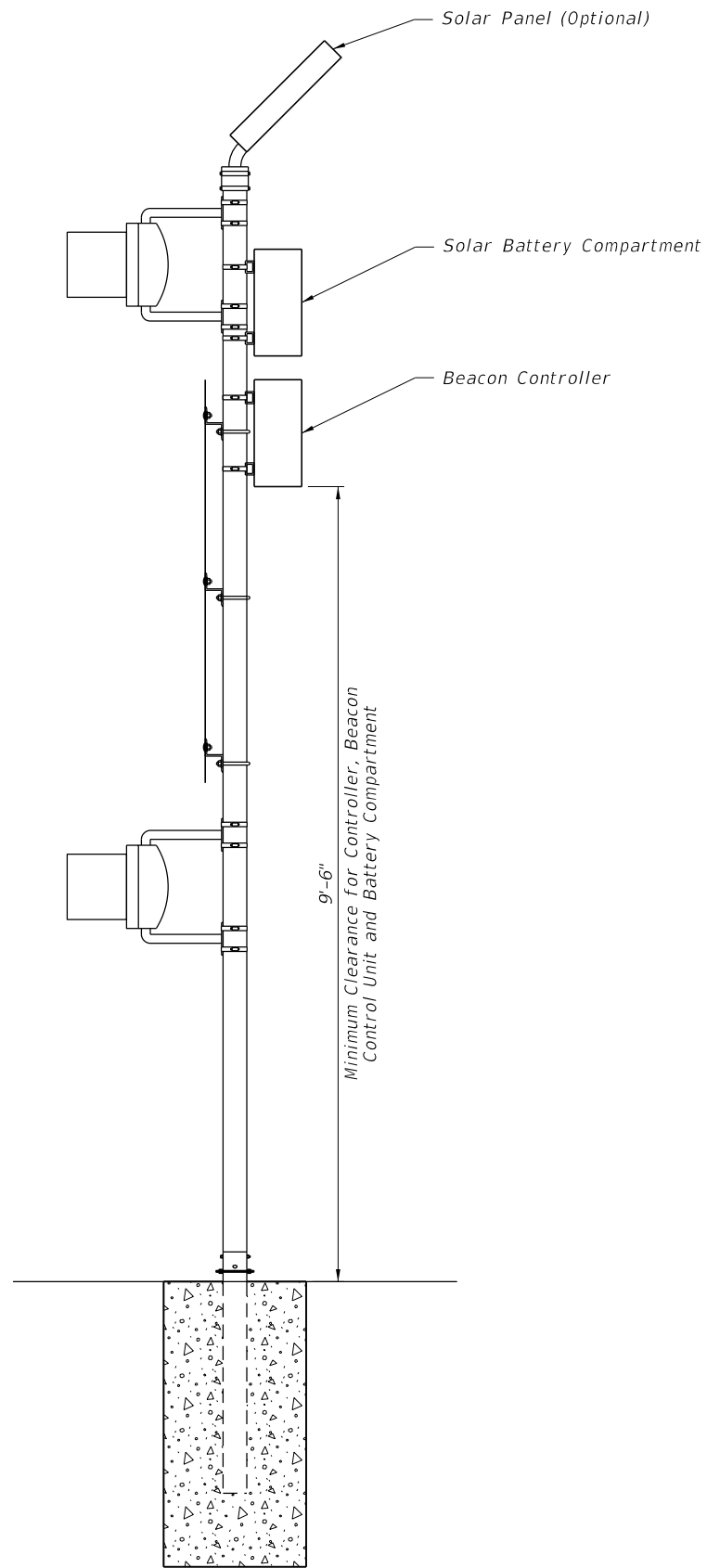

SIDE VIEW

STANDARD WARNING SIGN COLUMN SIZE			
Wind Speed	Sign Height	Column Size	Footing Depth
110	7'	4"	4'
130	7'	4.5"	4'
150	7'	5"	4.5'
110	8.5'	4.5"	4'
130	8.5'	5"	4.5'
150	8.5'	6"	5'

NOTES

1. Details show a typical warning sign with two flashing beacon heads. When only one beacon is required, install upper beacon.
2. Sign column slip base shall be in accordance with Design Standard Index 11860.
3. Beacon and beacon controllers shall be listed on Approved Products List (APL).

SOLAR POWERED WARNING SIGN DETAILS

6/30/2015 9:25:42 AM

LAST REVISION	DESCRIPTION:
12/15/14	



ROADSIDE FLASHING BEACON ASSEMBLY

INDEX NO.
11862

SHEET NO.
3 of 7

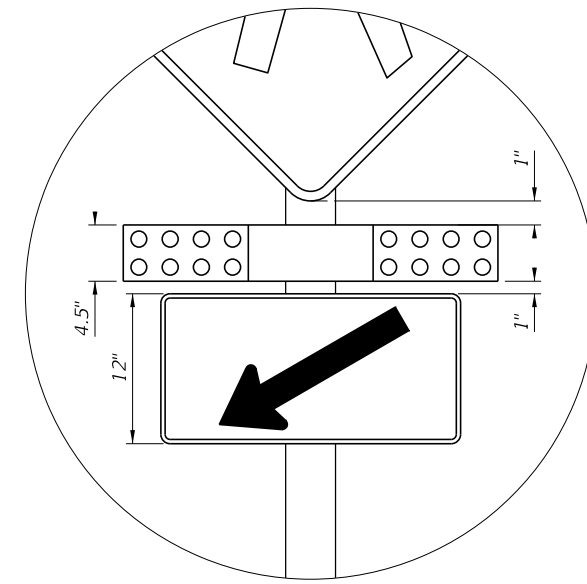
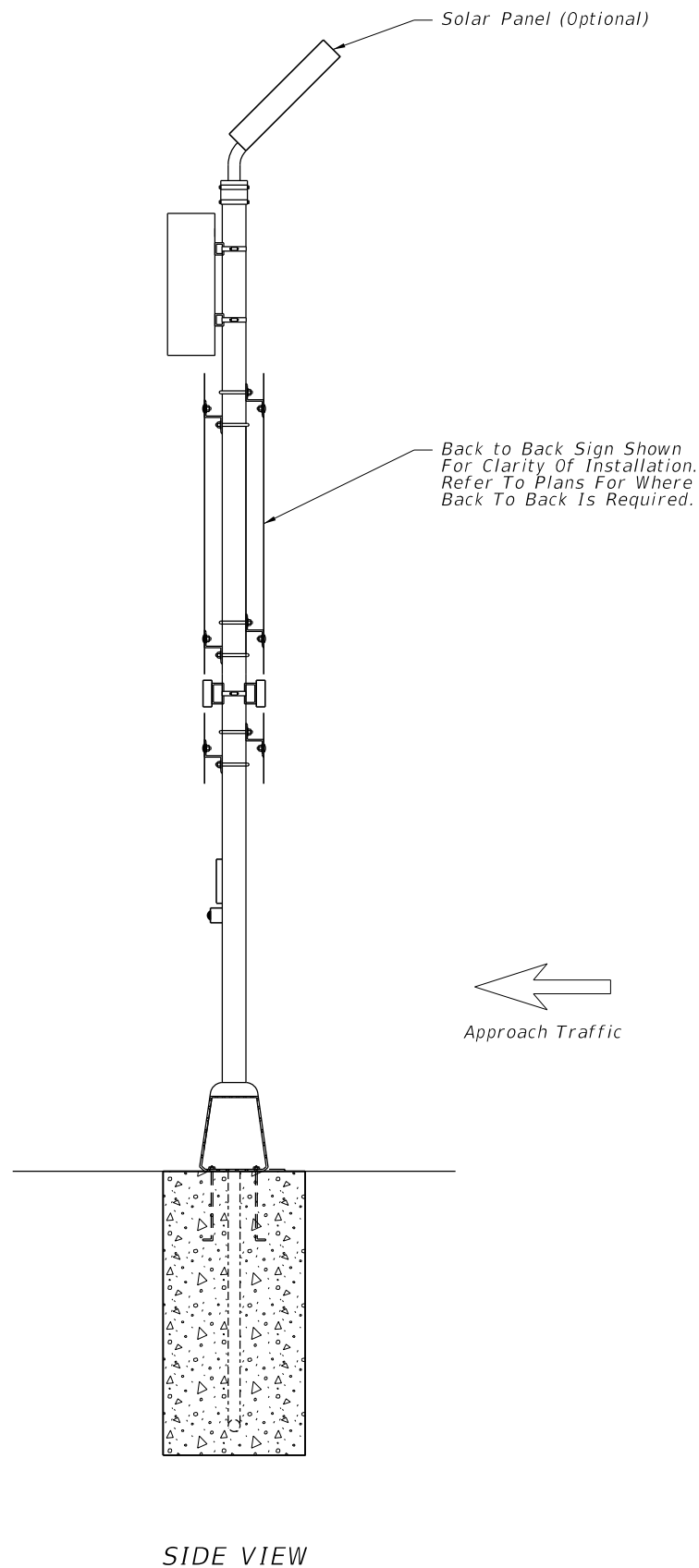
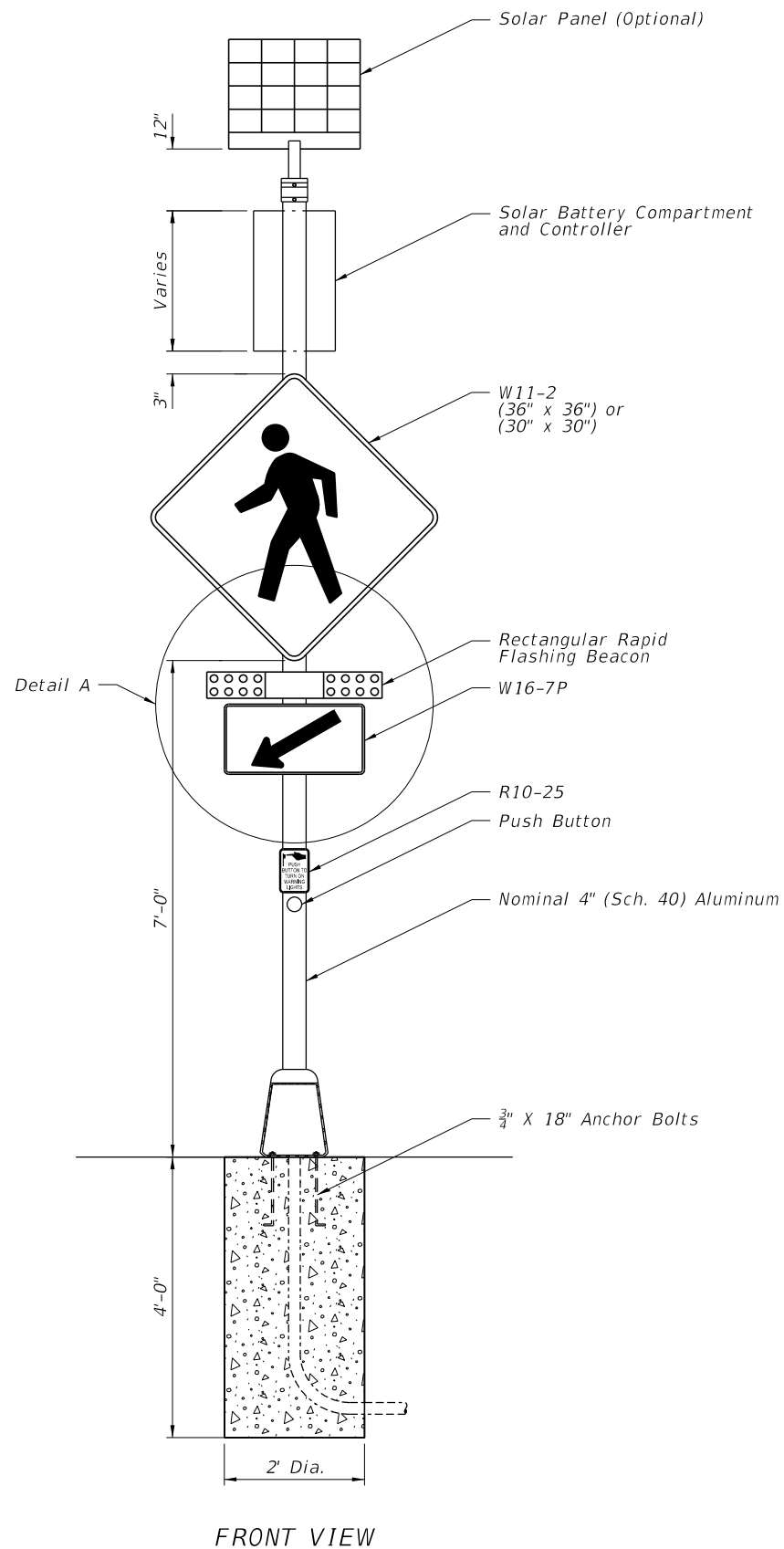

DETAIL A

NOTES

1. Rectangular Rapid Flashing Beacon (RRFB) shall always be installed in pairs, one on either side of approach traffic.
2. Controller shall be installed on the backside of post from approach traffic.
3. All RRFB equipment and hardware shall be listed on the Approved Products List (APL).
4. The W11-2 sign shall be 30" X 30" for single lane facilities and a 36" X 36" sign for multi-lane facilities.

FRONT VIEW

SIDE VIEW

RECTANGULAR RAPID FLASHING BEACON DETAILS

6/30/2015 2:05:30 PM

LAST REVISION	07/01/15	REVISION	DESCRIPTION:
---------------	----------	----------	--------------



ROADSIDE FLASHING BEACON ASSEMBLY

INDEX NO.
11862

SHEET NO.
4 of 7

6/30/2015 9:25:43 AM

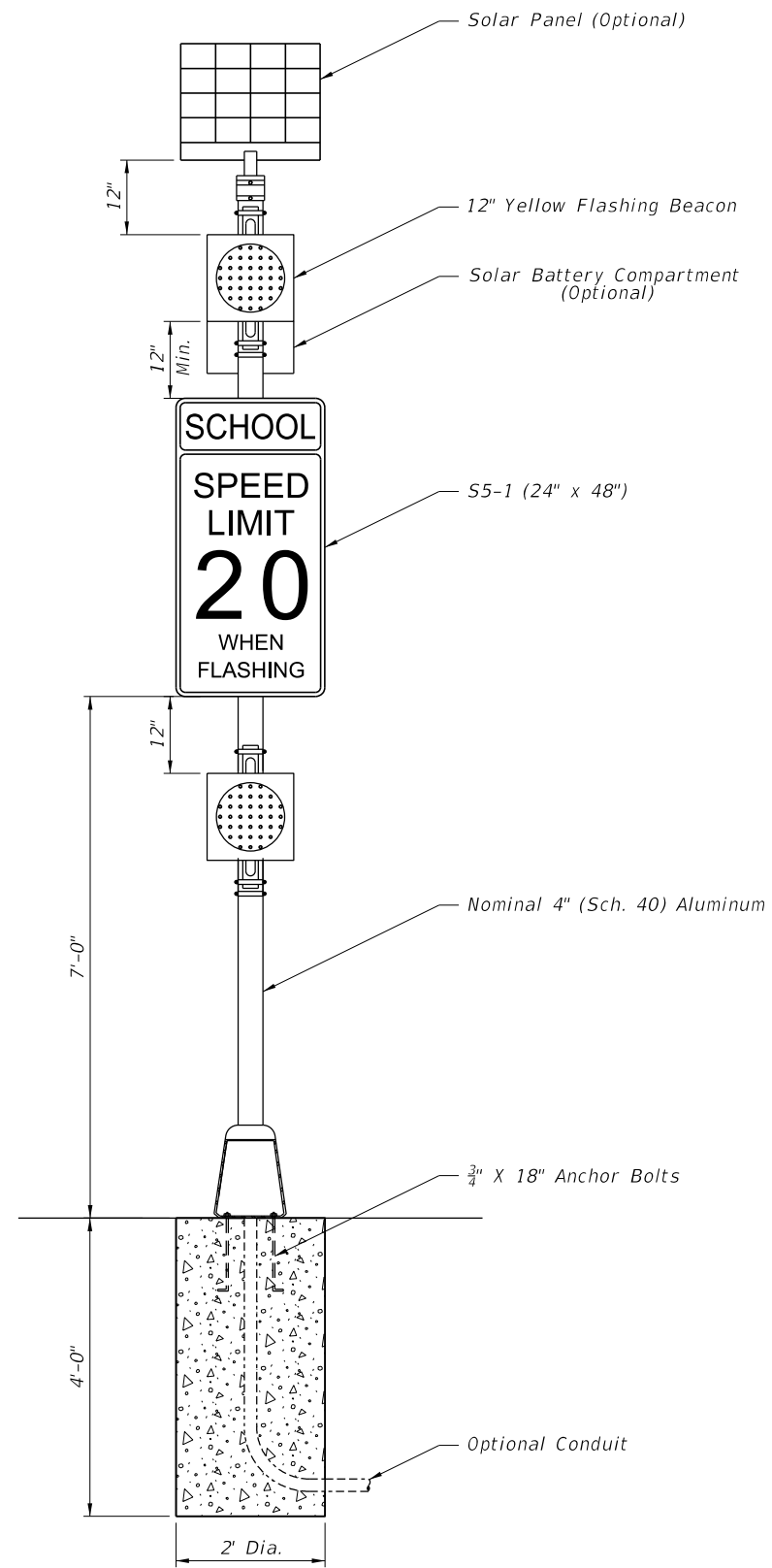

FRONT VIEW

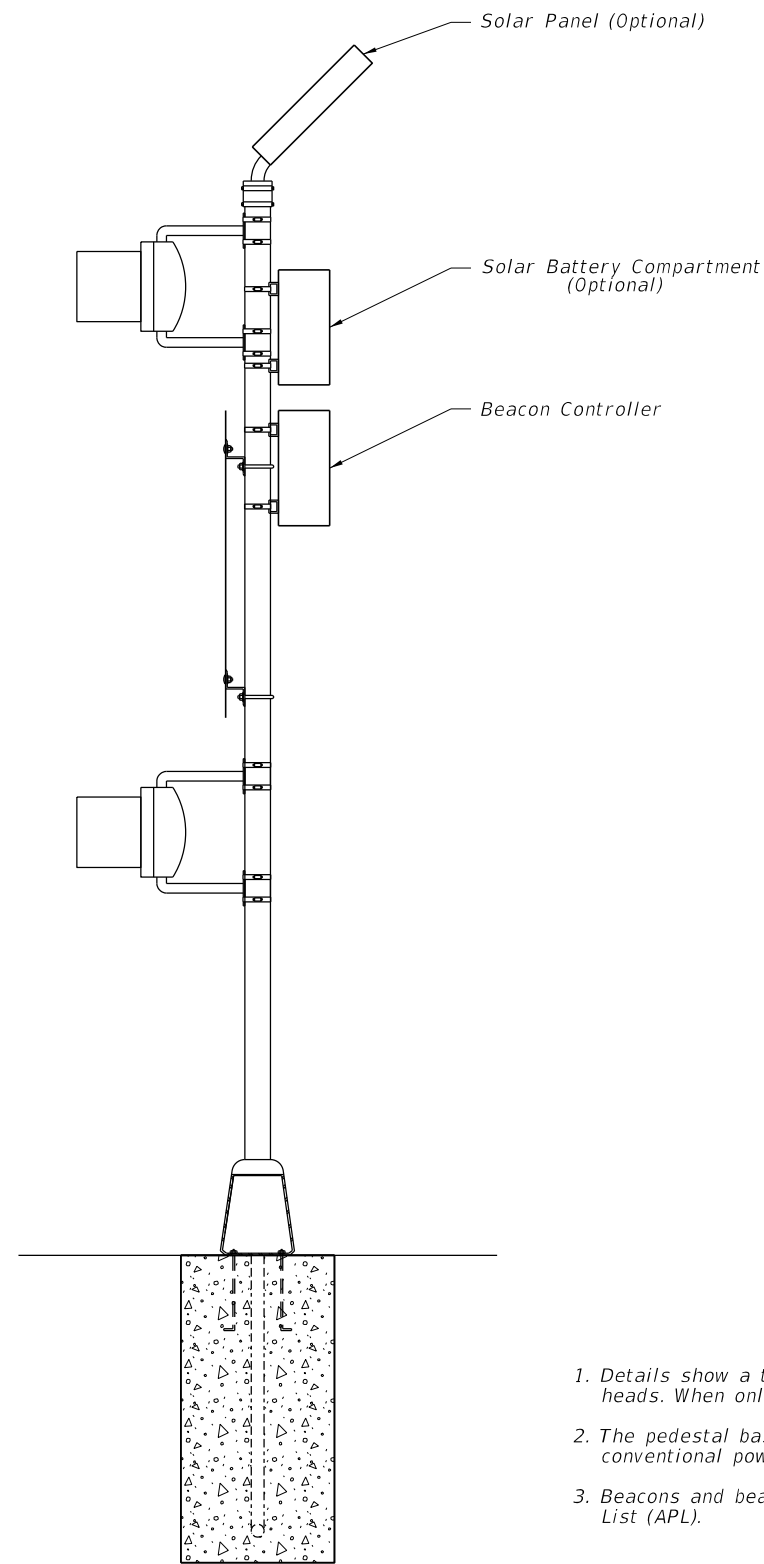

SIDE VIEW

NOTES

1. Details show a typical school zone sign with two flashing beacon heads. When only one beacon is required, install upper beacon.
2. The pedestal base shall be required for both solar powered and conventional powered applications.
3. Beacons and beacon controllers shall be on the Approved Products List (APL).

SCHOOL REGULATORY SIGN DETAILS

LAST REVISION 07/01/15	REVISION	DESCRIPTION:	 2016 DESIGN STANDARDS	ROADSIDE FLASHING BEACON ASSEMBLY	INDEX NO. 11862	SHEET NO. 5 of 7
---------------------------	----------	--------------	--	--	---------------------------	----------------------------

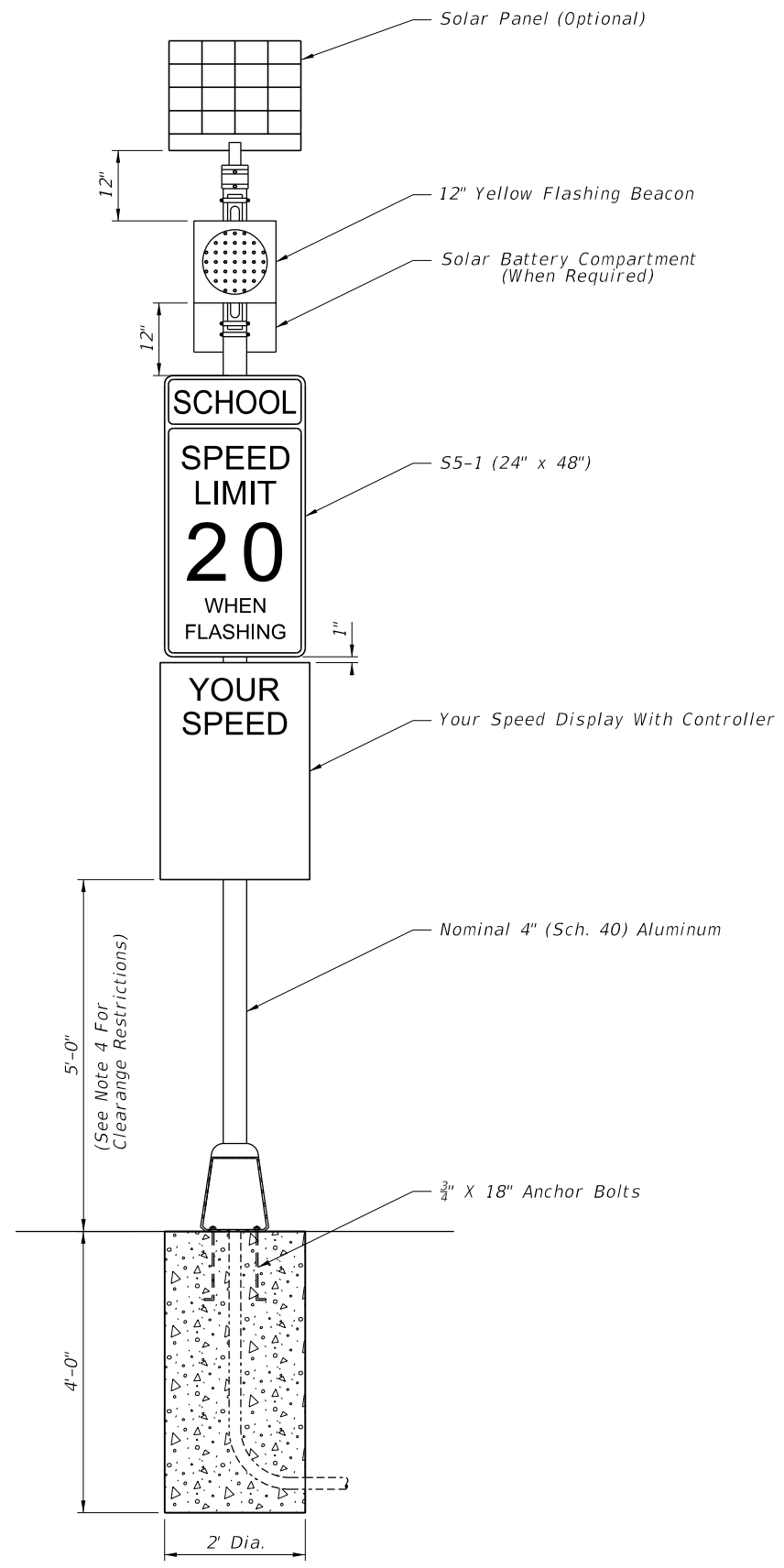

FRONT VIEW

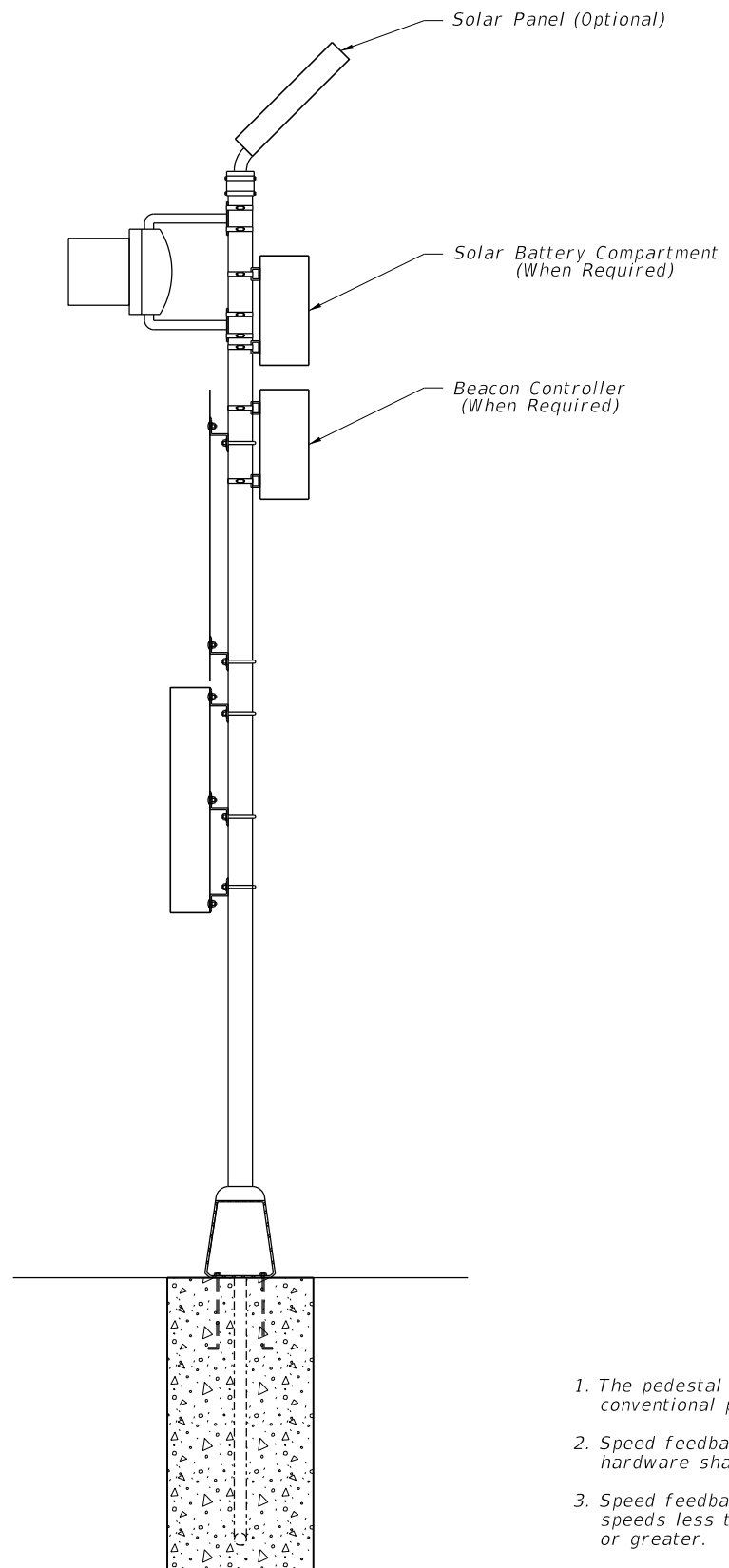

SIDE VIEW

NOTES

1. The pedestal base shall be required for both solar powered and conventional powered applications.
2. Speed feedback display, beacons, beacon controllers and installation hardware shall be on the Approved Products List (APL).
3. Speed feedback display shall indicate 15" numeral heights for posted speeds less than 45 mph and 18" heights for posted speeds 45 mph or greater.
4. Only speed display units weighing 62 lbs. or less may be mounted with a 5'-0" clearance. Speed display units weighing more than 62 lbs. shall be mounted with a 7'-0" clearance.

SCHOOL REGULATORY WITH SPEED FEEDBACK DETAILS

6/30/2015 9:25:43 AM

LAST REVISION 07/01/15	REVISION	DESCRIPTION:	 2016 DESIGN STANDARDS	ROADSIDE FLASHING BEACON ASSEMBLY	INDEX NO. 11862	SHEET NO. 6 of 7
---------------------------	----------	--------------	---	--	---------------------------	----------------------------

6/30/2015 9:25:44 AM

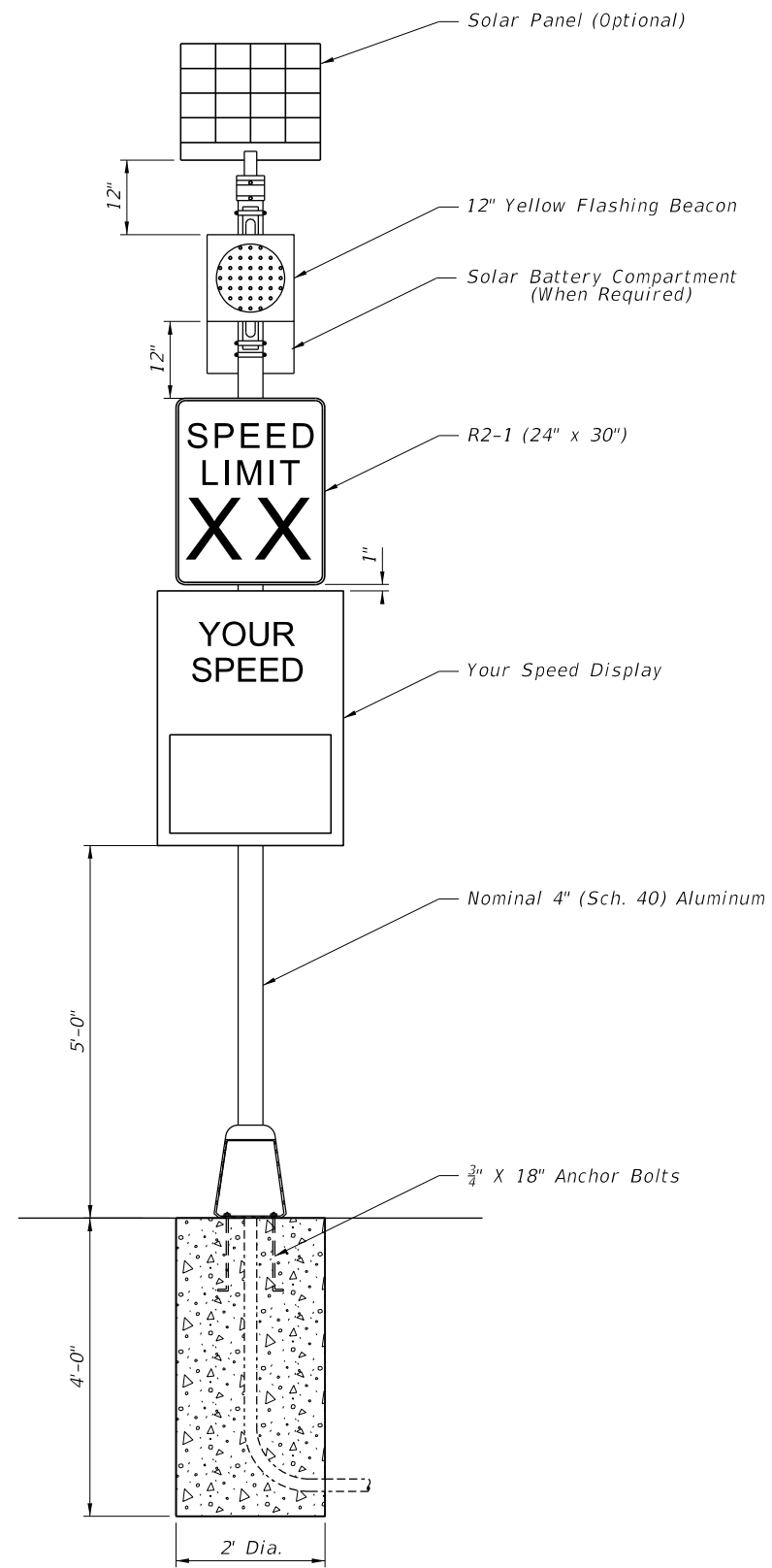

FRONT VIEW

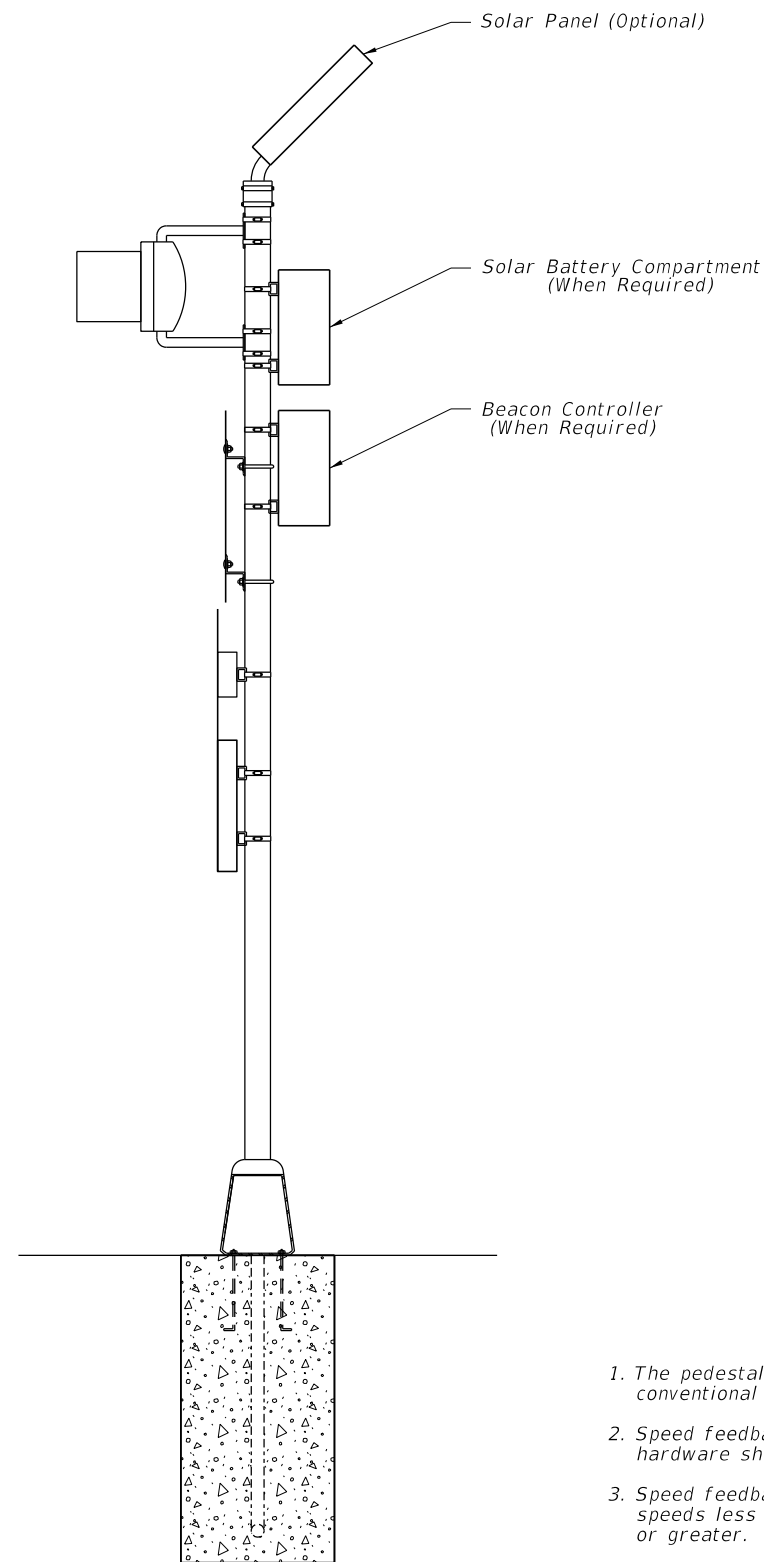

SIDE VIEW

NOTES

1. The pedestal base shall be required for both solar powered and conventional powered applications.
2. Speed feedback display, beacons, beacon controllers and installation hardware shall be on the Approved Products List (APL).
3. Speed feedback display shall indicate 15" numeral heights for posted speeds less than 45 mph and 18" heights for posted speeds 45 mph or greater.
4. Only speed display units weighing 62 lbs. or less may be mounted with a 5'-0" clearance. Speed display units weighing more than 62 lbs. shall be mounted with a 7'-0" clearance.

REGULATORY SIGN WITH SPEED FEEDBACK DETAILS

LAST REVISION 07/01/15	REVISION	DESCRIPTION:	 2016 DESIGN STANDARDS	ROADSIDE FLASHING BEACON ASSEMBLY	INDEX NO. 11862	SHEET NO. 7 of 7
---------------------------	----------	--------------	---	--	---------------------------	----------------------------