

PLAN
JUNCTION SLAB ADJACENT TO SKEWED APPROACH SLAB AND WITH BARRIER WALL INLET

EXPANSION JOINT DETAIL
 (Junction Slab expansion joints are required at 3/4" open joints in Traffic Railing/Noise Wall)

NOTES

1. CONSTRUCTION REQUIREMENTS: Construct the expansion joints and face of coping plumb.
2. CONCRETE: Use Class II concrete for slightly aggressive environments. Use Class IV concrete for moderately or extremely aggressive environments. Concrete will be in accordance with Specification Section 346.
3. DOWELS: Dowel Load Transfer Devices will be hot-dip galvanized ASTM A36 smooth round bars or GFRP smooth round bars with a minimum shear strength of 22ksi in accordance with ASTM D7617. Install Dowel Load Transfer Devices in accordance with Specification Section 350.
4. EXPANSION JOINTS: Construct 3/4" Expansion Joints plumb, and either perpendicular or radial to Gutter Line. Provide at 90'-0" maximum intervals as shown.
5. Shear Keys in Junction Slab are required when GFRP bars are used for Dowel Transfer Devices and are optional with steel dowel bars. Tongue Slope on Shear Key must be constant and between 5° to 45° from horizontal.
6. Provide two layers of 30 Lb. Roofing Felt on top and Expanded Polystyrene (1/2" thick) on sides.
7. V-GROOVES: Construct 1/2" V-Grooves plumb and provide at 30'-0" maximum intervals as shown. Space V-Grooves equally between 3/4" Expansion Joints and/or Begin or End Junction Slab. V-Groove locations are to coincide with V-Groove locations in the Railing/Noise Wall.
8. FILL REQUIREMENTS: Shoulder or Roadway Pavement or Fill is required on top of the junction slab for its entire length on the traffic side of the Railing/Noise Wall. See Section B-B for details.
9. Actual location & width vary depending on type of Retaining Wall used.
10. Field cut Bars 5A and 5B as required to maintain minimum cover for skewed Approach Slab.
11. Spacing shown is along the Gutter Line.
12. See Index No. 5210 for Bars 5V and 5S1. See Plans for Junction Slab width (TYPE).
13. Work this Index with Index 5210 - Traffic Railing/Noise Wall (8'-0").

CROSS REFERENCE:
 For Section B-B and Detail "A", see Sheet 2.

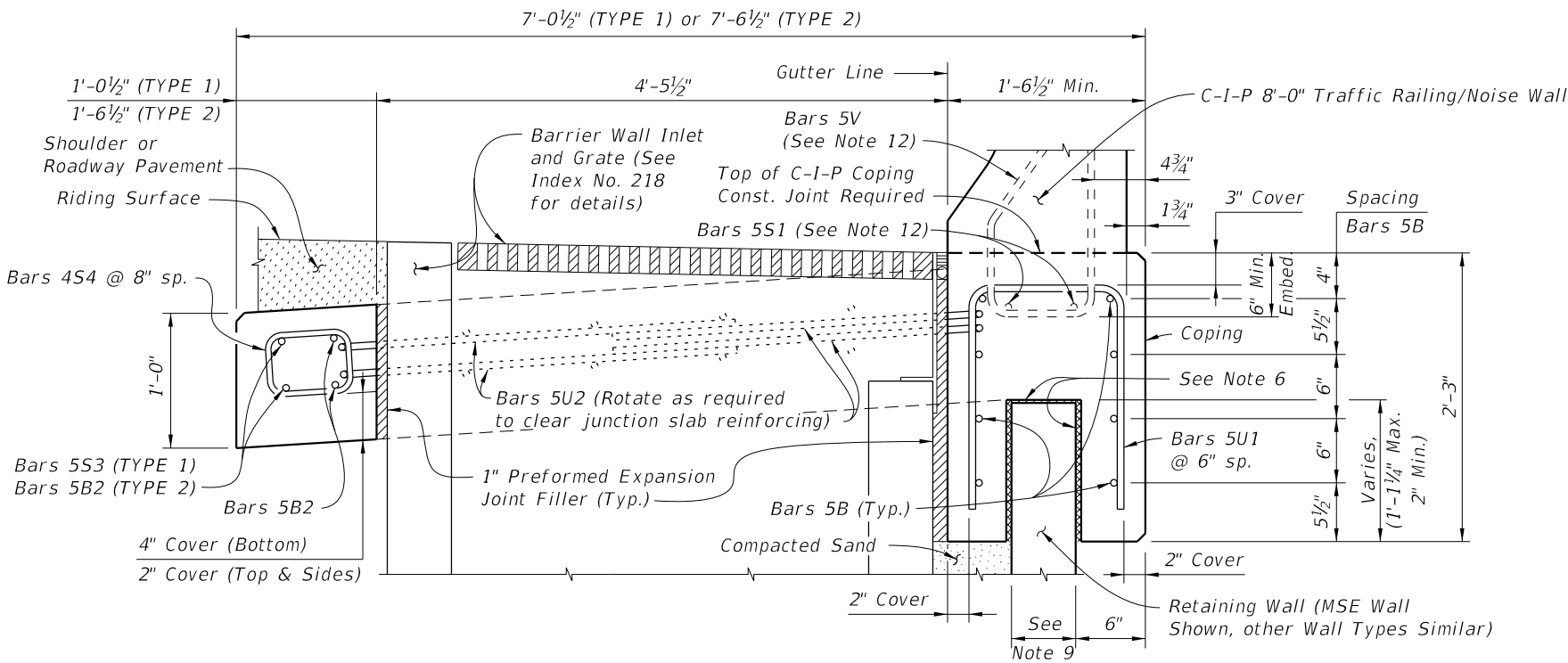

SECTION A-A
SECTION THRU JUNCTION SLAB, BARRIER WALL INLET AND RETAINING WALL
 (TYPE 1 Junction Slab Shown, TYPE 2 Similar)

6/24/2015 6:53:17 AM

LAST REVISION	07/01/15	DESCRIPTION:	 2016 DESIGN STANDARDS	TRAFFIC RAILING/NOISE WALL (8'-0") JUNCTION SLAB	INDEX NO. 5212	SHEET NO. 1 of 2
---------------	----------	--------------	----------------------------------	---	--------------------------	----------------------------

REINFORCING STEEL BENDING DIAGRAMS

BILL OF REINFORCING STEEL

MARK	SIZE	LENGTH	
		TYPE 1	TYPE 2
A	5	8'-0"	9'-0"
B	5	AS REQ'D.	AS REQ'D.
C	5	4'-8"	5'-8"
L	5	4'-5"	4'-5"
S3	5	10'-0"	N/A
S4	4	3'-1"	4'-0"
U1	5	4'-9"	4'-9"
U2	5	12'-10"	12'-10"
DOWEL	1" Ø Smooth Bar	2'-0"	2'-0"

REINFORCING STEEL NOTES:

1. All bar dimensions in the bending diagrams are out to out.
2. All reinforcing steel at the open joints will have a 2" minimum cover.
3. Lap splices for Bars 5B will be a minimum of 2'-0".
4. The Contractor may use Welded Wire Reinforcement (WWR) when approved by the Engineer. WWR must consist of Deformed wire meeting the requirements of Specification Section 931.

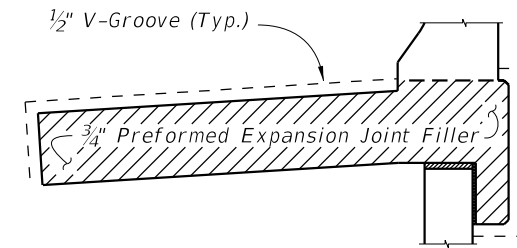
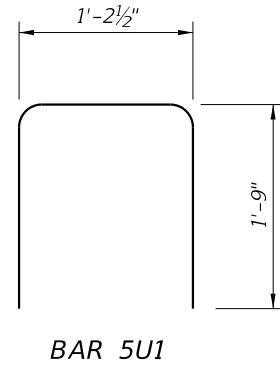
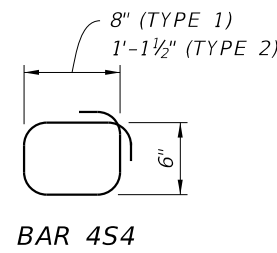
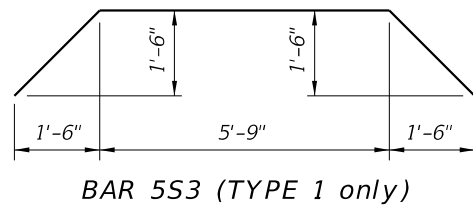
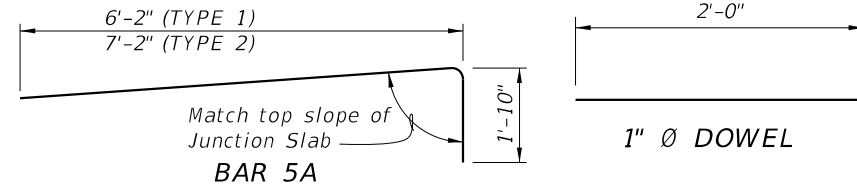

DETAIL "A"
(Showing Locations of 1/2" V-Grooves and 3/4" Preformed Expansion Joint Filler)

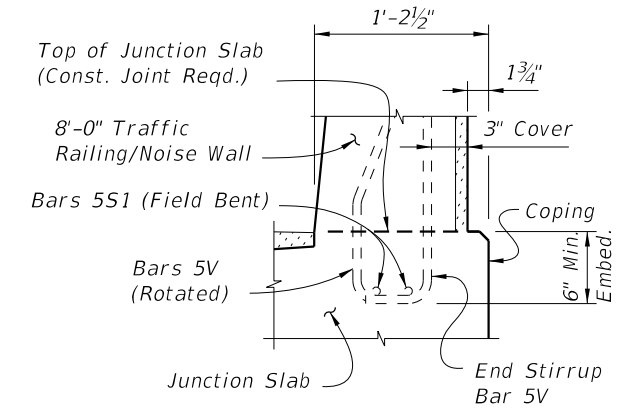

PARTIAL END VIEW OF RAILING END TRANSITION FOR GUARDRAIL ATTACHMENT
(Showing Bars 5V and Bars 5S1)

NOTE: See Index No. 5210, Detail "A" for details.

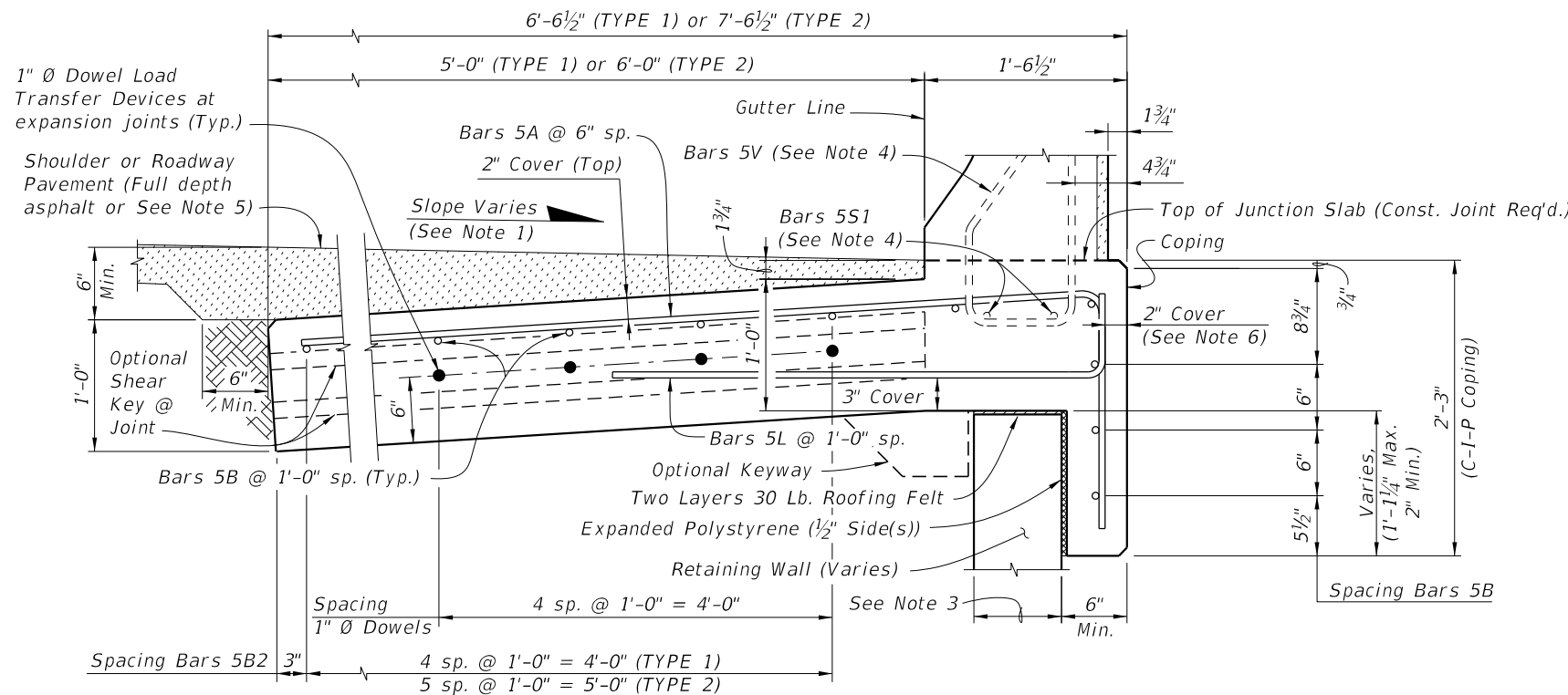

SECTION B-B
TYPICAL SECTION THRU JUNCTION SLAB AND RETAINING WALL

ESTIMATED JUNCTION SLAB QUANTITIES

ITEM	UNIT	QUANTITY	
		TYPE 1	TYPE 2
Concrete (Junction Slab)	CY/FT	0.268	0.305
Reinforcing Steel (Typical)	LB/FT	30.91	34.04
Additional Reinf. @ Expansion Joint	LB	21.36	21.36

NOTES:

1. Match Cross Slope of Travel Lane or Shoulder.
2. Vary Junction Slab slope based on roadway cross slope to maintain a minimum 6" asphalt depth at the edge of the slab as shown.
3. Actual width varies depending on type of Retaining Wall used.
4. See Index No. 5210 for Bars 5V and 5S1.
5. For Rigid Pavement (Concrete), Junction Slab may be thickened to match finished grade.
6. If slip forming is used, submit shop drawings for approval showing 3" side cover with adjusted Typical Section dimensions.

CROSS REFERENCE:

For location of Section B-B, see Sheet 1.

6/24/2015 6:53:18 AM

LAST REVISION 07/01/15	DESCRIPTION:
---------------------------	--------------