

CONCRETE ENDWALL WITH U-TYPE WINGS FOR PIPE CULVERTS

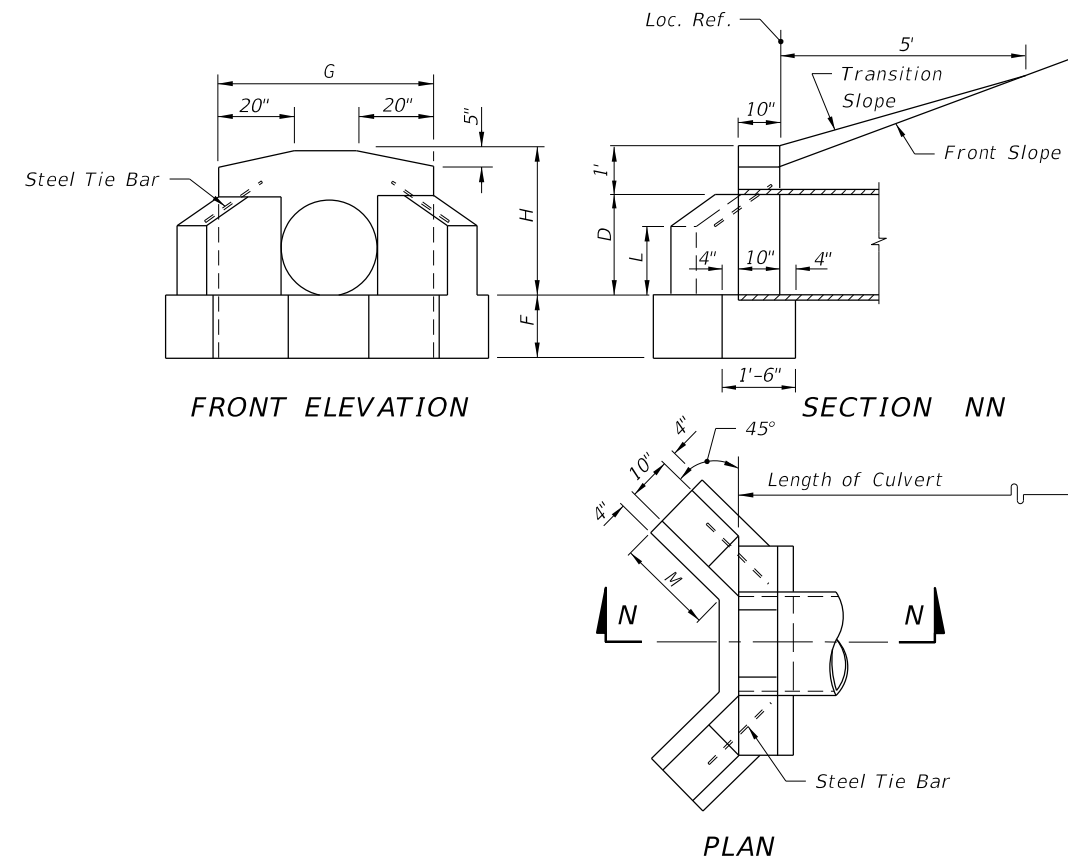

CONCRETE ENDWALL WITH 45° WINGS FOR PIPE CULVERTS

TABLE OF DIMENSIONS AND ESTIMATED QUANTITIES  
PIPE CULVERT ENDWALLS WITH U-TYPE WINGS

DIMENSIONS		QUANTITIES IN ONE ENDWALL											
Opening D	Area (ft <sup>2</sup> )	Wall			Footing		Concrete, Class I, Total (CY)						Steel Tie Bars
		G	H	K	F	J	RCP		CMP		CIP		
							Inlet	Outlet	Inlet	Outlet	Inlet	Outlet	
12"	0.8	3'-8"	2'-0"	1'-0"	1'-3"	2'-2"	0.48	0.55	0.49	0.57	0.49	0.57	none
15"	1.2	3'-11"	2'-3"	1'-5"	1'-3"	2'-7"	0.59	0.67	0.62	0.70	0.61	0.70	none
18"	1.8	4'-2"	2'-6"	1'-9"	1'-3"	2'-11"	0.70	0.79	0.74	0.82	0.74	0.82	none
24"	3.1	4'-8"	3'-0"	2'-6"	1'-6"	3'-8"	1.01	1.11	1.06	1.16	1.06	1.16	2-#6 Bars x 2'-0"
30"	4.9	5'-2"	3'-6"	3'-3"	1'-6"	4'-5"	1.33	1.44	1.41	1.51	1.40	1.51	2-#6 Bars x 2'-0"
36"	7.1	5'-8"	4'-0"	4'-0"	1'-9"	5'-2"	1.73	1.85	1.84	1.96	1.82	1.94	2-#6 Bars x 2'-6"
42"	9.6	6'-2"	4'-6"	4'-9"	2'-0"	5'-11"	2.19	2.32	2.32	2.45			2-#6 Bars x 2'-6"
48"	12.6	6'-8"	5'-0"	5'-6"	2'-0"	6'-8"	2.64	2.78	2.81	2.95			2-#6 Bars x 3'-0"

TABLE OF DIMENSIONS AND ESTIMATED QUANTITIES  
PIPE CULVERT ENDWALLS WITH 45° WINGS

DIMENSIONS		QUANTITIES IN ONE ENDWALL										
Opening D	Area (ft <sup>2</sup> )	Wall			Footing	Concrete, Class I			Steel Tie Bars			
		H	G	L	M	F	Total (CY)					
							RCP	CMP	CIP			
15"	1.2	2'-3"	3'-7"	1'-0"	1'-3"	1'-3"	0.56	0.59	0.59	none		
18"	1.8	2'-6"	3'-10"	1'-2"	1'-7"	1'-3"	0.74	0.77	0.77	none		
24"	3.1	3'-0"	4'-4"	1'-5"	2'-1"	1'-4"	1.01	1.06	1.06	2-#6 Bars x 2'-0"		
30"	4.9	3'-6"	4'-10"	1'-9"	2'-5"	1'-6"	1.32	1.40	1.39	2-#6 Bars x 2'-0"		
36"	7.1	4'-0"	5'-4"	2'-0"	2'-11"	1'-8"	1.72	1.83	1.82	2-#6 Bars x 2'-6"		
42"	9.6	4'-6"	5'-10"	2'-3"	3'-6"	2'-0"	2.34	2.47		2-#6 Bars x 2'-6"		
48"	12.6	5'-0"	6'-4"	2'-6"	4'-0"	2'-0"	2.74	2.90		2-#6 Bars x 2'-6"		

GENERAL NOTES

1. Winged concrete endwalls are intended for use outside the clear zone.
2. Chamfer all exposed edges 3/4".
3. Concrete shall be Class I, except ASTM C478 (4000 psi) Concrete may be substituted for precast items manufactured in plants meeting the requirements of Section 449 of the Specifications.
4. Endwall to be paid for under the contract unit price for Class I Concrete.
5. Sodding to be in accordance with Index No. 281, and paid for under the contract unit price for Performance Turf, SY.

6/8/2015 9:57:48 AM

LAST REVISION 07/01/09	REVISION	DESCRIPTION:	 <b>2016</b> DESIGN STANDARDS	<b>WINGED CONCRETE ENDWALLS SINGLE ROUND PIPE</b>	INDEX NO. <b>266</b>	SHEET NO. <b>1 of 1</b>
---------------------------	----------	--------------	--	---	-------------------------	----------------------------