

RECOMMENDED MAXIMUM PIPE SIZES	
INLET INSIDE WIDTH	PIPE SIZE
2'-11" or 3'-3"	24"
4'-0" or 3'-10"	30"

Note: Recommended sizes are for concrete pipe. Sizes for other types of pipe must be verified for fit in accordance with Index No. 201. For larger pipe see bottom detail below and Index No. 200.

HORIZONTAL WALL REINFORCING SCHEDULE (TABLE 1)				
WALL DEPTH	SCHEDULE	AREA (in <sup>2</sup> /ft)	MAX. SPACING	
			BARS	WWF
0'-5'	A12	0.20	12"	8"
5'-9'	A6	0.20	6"	5"
9'-12'	A4	0.20	4"	3"
9'-15'	B5.5	0.24	5½"	5"

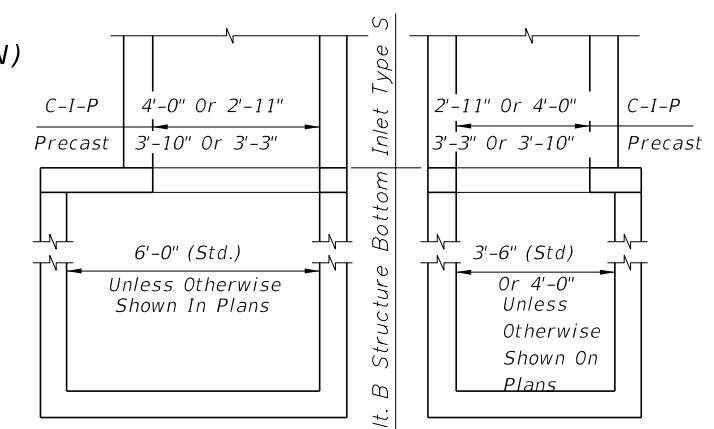

NOTE: Alt. B Structure Bottom Only. See Index No. 200 for structure bottom details and hole reinforcement.

INLET WITH STRUCTURE BOTTOM

GENERAL NOTES

1. This inlet is intended for use in shoulder gutter on facilities subject to heavy wheel loads. The parallel bar grate shall be used on limited access facilities. On other facilities the reticuline grate shall be used. Locate inlet outside of pedestrian way.
2. All reinforcing is Grade 60 bars with 2" min. cover unless otherwise noted. See Index No. 201 for equivalent area of welded wire fabric. Bars to be cut or bent for 1½" minimum clearance around pipe.
3. All exposed edges and corners shall be ¾" chamfer or tooled to ¼" radius.
4. When Alternate G grate is specified in plans, the grate is to be hot-dip galvanized after fabrication.
5. For supplementary details and notes see Index Nos. 200 and 201.
6. All dimensions are for both precast and cast-in-place inlets unless otherwise noted.
7. Inlets to be paid for under the contract unit price for inlets (Gutter Type S), EA. Cost of concrete apron at terminal inlets to be included in the cost of the inlet.

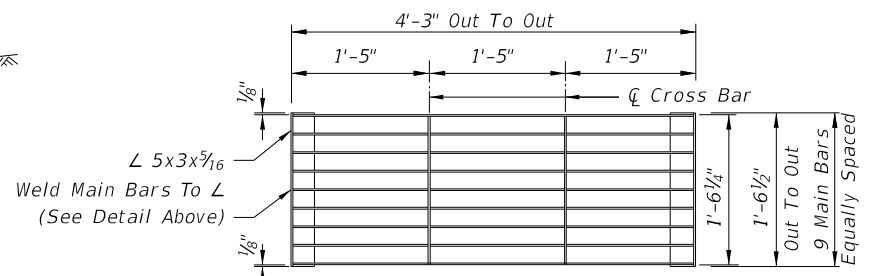
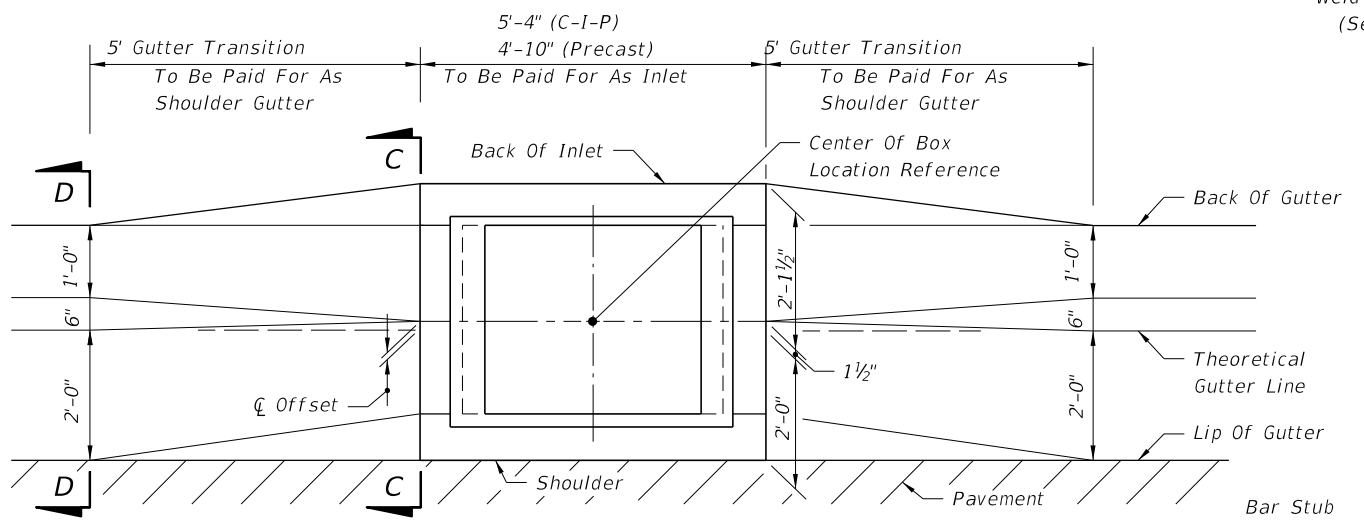
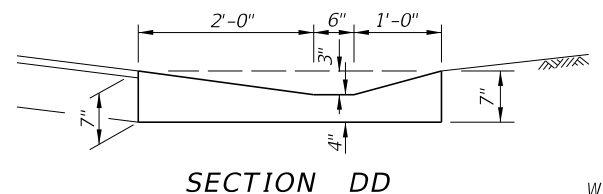
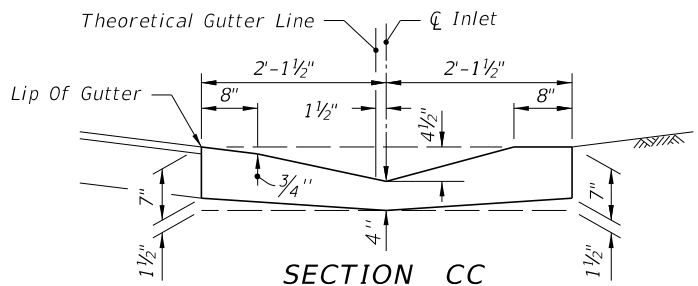

Main Bars 5"x¼" (Notched For Cross Bars)  
Cross Bars 1¾"x¼" (¾" Continuous Weld At Main Bar Notches)  
Main Bars and Cross Bars Flush On Top

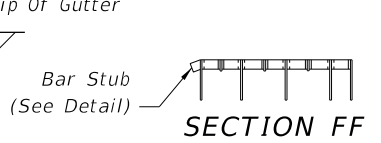
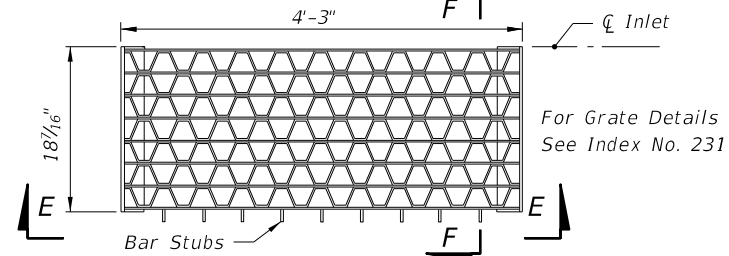

SECTION EE  
STEEL GRATE

7/8/2015 9:36:33 AM

LAST REVISION	DESCRIPTION:
07/01/10	

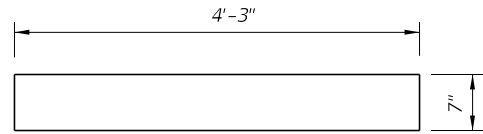

SECTION BB  
(Enlarged)

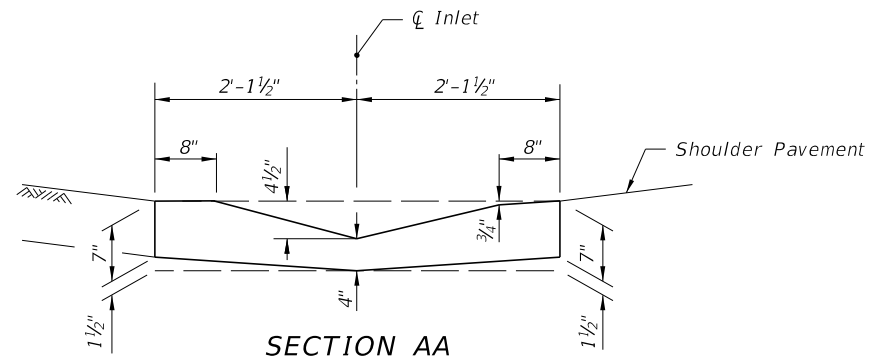

SECTION AA  
(Enlarged)

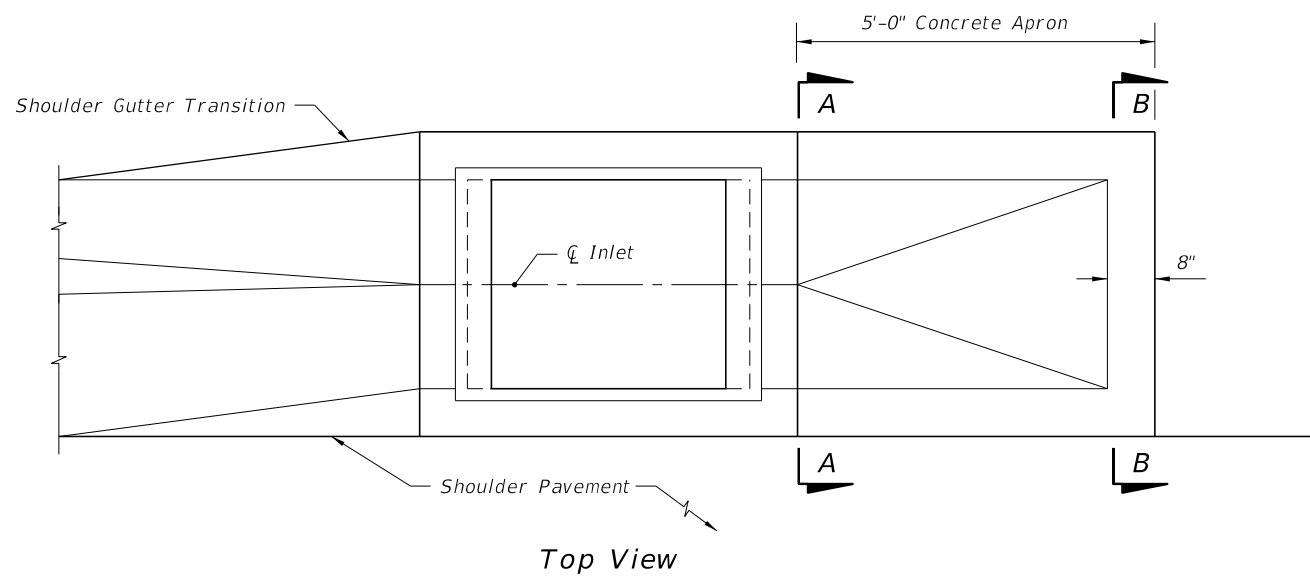

Top View

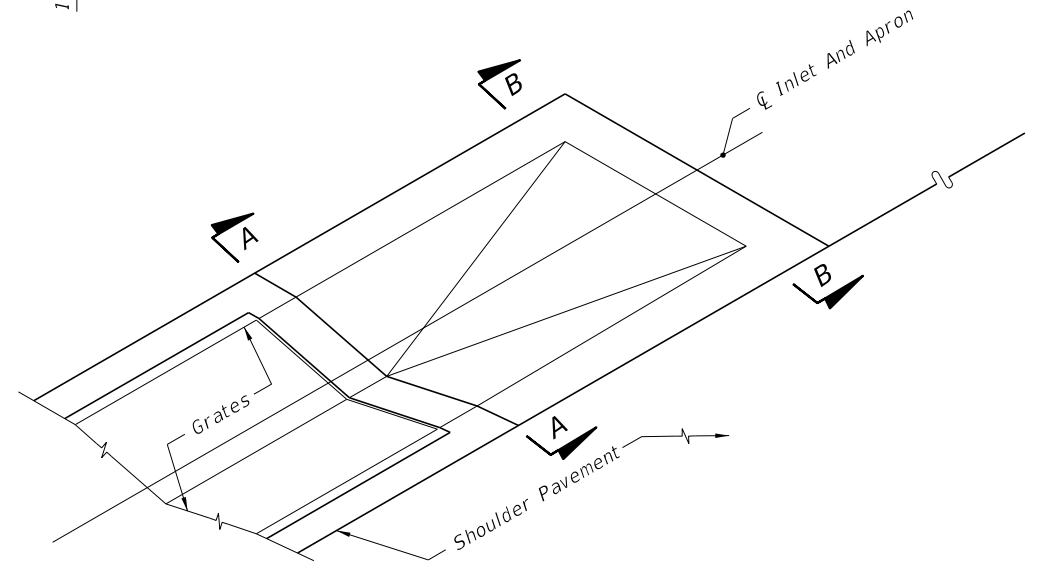

PICTORIAL VIEW

Apron To be Constructed At The Most Downstream Inlet In A Run Of Shoulder Gutter  
**CONCRETE APRON AT TERMINAL INLETS**

6/8/2015 9:29:19 AM

LAST REVISION 07/01/07	DESCRIPTION:
---------------------------	--------------



GUTTER INLET TYPE S

INDEX NO.  
220

SHEET NO.  
2 of 3

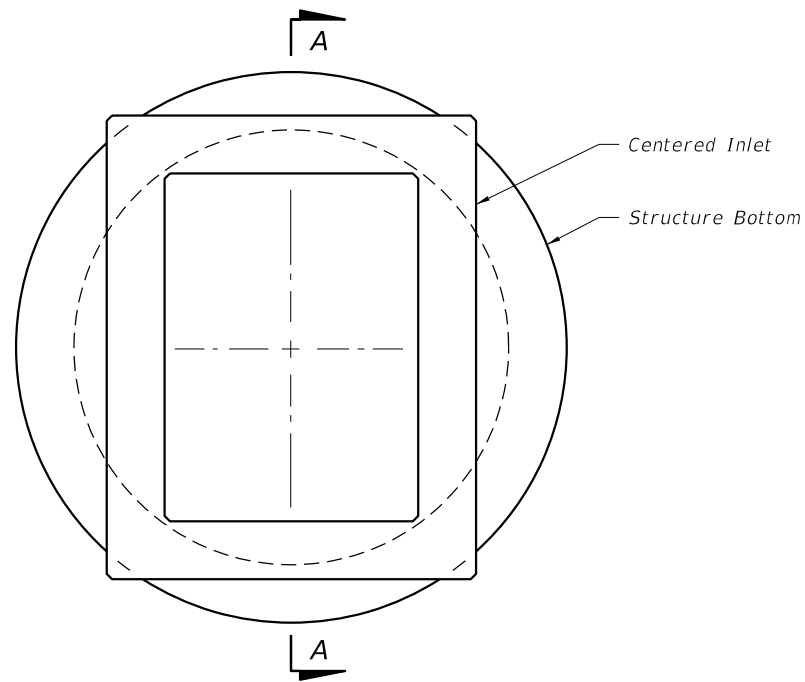

TOP VIEW

TOP SLAB OPENINGS		
DIAMETER	OPENING SIZE	
	MIN.	MAX.
5'-0" To 8'-0"	2'-11" x 4'-0"	3'-3" x 3'-10"

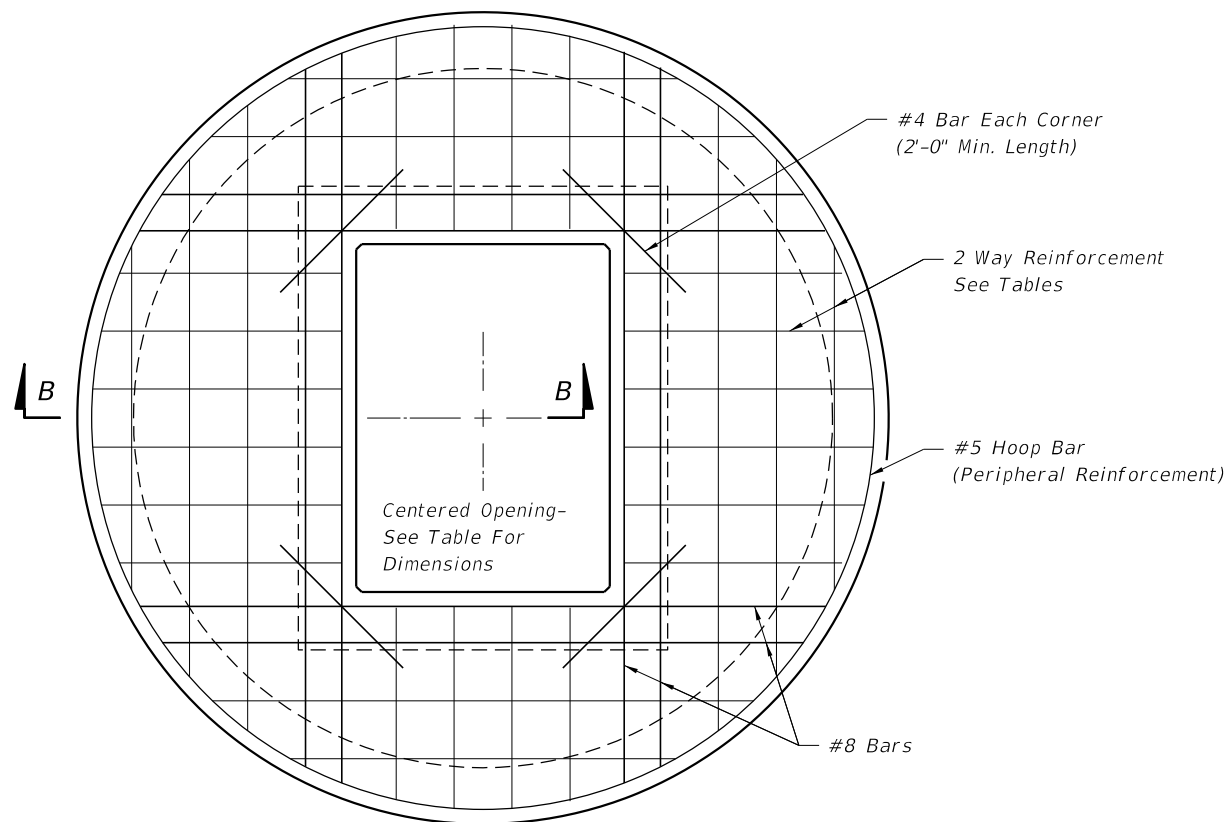

TOP SLAB REINFORCING DIAGRAM

TOP SLAB REINFORCING SCHEDULE	
GRADE 60 (BAR) OR 65 KSI & 70 KSI (WIRE FABRIC)	
SCHEDULE	In <sup>2</sup> /ft.
A	0.20
B	0.24
C	0.37
D	0.53
E	0.73
F	1.06
G	1.45

TOP SLAB WITH CENTERED OPENING		
SLAB DEPTH	SLAB THICKNESS	REINFORCING (2 WAYS) SCHEDULE
SIZE: 5'-0"		
≥0.5' < 30'	9½"	C
30' - 40'	9½"	D
SIZE: 6'-0"		
≥0.5' < 8'	9½"	B
8' < 18'	9½"	C
18' < 30'	9½"	D
30' < 37'	9½"	E
37' - 40'	9½"	G
SIZE: 8'-0"		
≥0.5' < 9'	11½"	C
9' < 15'	11½"	D
15' < 23'	11½"	E
23' < 33'	11½"	E
33' - 40'	11½"	G

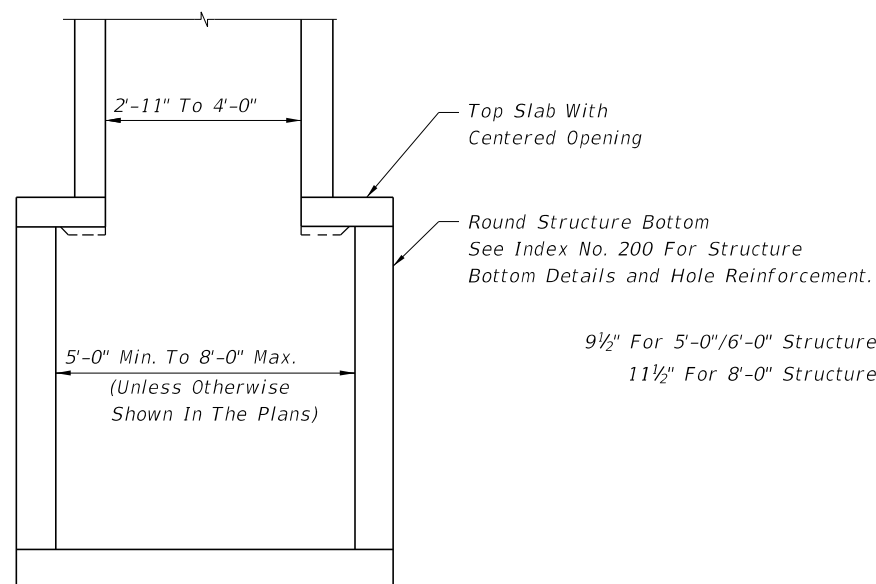

SECTION AA

9½" For 5'-0"/6'-0" Structure Bottoms  
11½" For 8'-0" Structure Bottoms

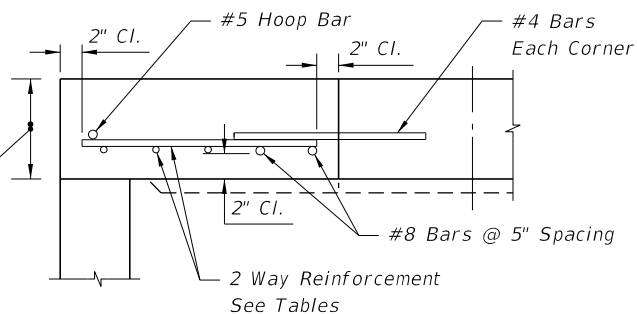

SECTION BB

ALT. A STRUCTURE BOTTOM FOR INLET TYPE S

6/8/2015 9:29:19 AM

LAST REVISION 07/01/05	DESCRIPTION:
---------------------------	--------------