

Index 852 Steel Pedestrian/Bicycle Railing (Rev. 07/14)

Design Criteria

Structures Design Guidelines (SDG 6.8)

Design Assumptions and Limitations

This railing is not applicable for shielding drop-off hazards for motor vehicle traffic. This railing is applicable for cases where a pedestrian or bicyclist drop-off hazard exceeds 5'-0" or when a drop-off hazard is less than 5'-0" and is required by design or permit stipulations. Refer to [PPM](#) Vol. 1, Chapters 4 & 8, for the definition of vehicular, pedestrian and bicyclist "drop-off hazards".

Indexes 852 and 862 are similar in form and function. Select which of these railings to use at a given site based on District preferences, aesthetic or finish color requirements, corrosion concerns, potential theft issues, fabrication issues, weight of railing and any other project specific requirements. In some cases, both of these railings are acceptable for use and it is left to the contractor to select by the use of Pay Item 515-2-1BB.

See [Index 851](#) for special requirements and modifications for use on bridges.

A handrail is required for use on ramps with a grade steeper than 5% to conform to the requirements of the Americans with Disabilities Act (ADA).

Expansion joints shall be spaced at a maximum 40'-0" (differs from Index 862). Railing must be continuous across a minimum of two posts.

For the railing anchorage to provide stability against overturning, the concrete foundation (sidewalk, retaining wall, curb, etc.) must meet or exceed the requirements in this Standard.

The following definitions apply to the use of this Standard; including Custom Infill Panels:

4" Sphere Rule - Clear openings of the railing below 31" height shall reject the passage of a 4" diameter sphere and clear openings above 31" height shall reject the passage of an 8" diameter sphere.

6" Sphere Rule - Clear openings of the railing below 27" height shall reject the passage of a 6" diameter sphere and clear openings above 27" height shall reject the passage of an 8" diameter sphere.

Refer to the SDG for locations where the 4" Sphere rule is applicable. Providing adequate sight distance always takes priority over the 4" Sphere Rule.

Aesthetics play a crucial role in the determination of which railing infill type should be specified for a particular project. Alternate Infill Panel designs within the Design Standard, include some that meet the 6" Sphere Rule and others that meet the 4" Sphere Rule. Custom Infill Panels must be designed to meet the Design Criteria live load, and the applicable 4" or 6" Sphere Rule. When designing Infill Panels, aesthetics is important; however, line of sight and safety issues must be a priority.

Typically the clear space between the top and intermediate horizontal rails provides for adequate sight distances; however, for railing installations adjacent to sloped intersections, the infill area between the intermediate and bottom horizontal rails may still adversely affect the sight distance. Of the standard infill alternatives that meet the 4" Sphere Rule, the standard "Type 2 - Chain-Link" infill alternative creates the least obstruction to sight distance through the infill areas.

When a colored coating is desired and the additional cost is justified or reimbursed by the requesting local agency, then specify a coating in accordance with FDOT Standard Specifications for Road and Bridge Construction, Section 649-4. See *PPM*, Volume 1, Section 8.8 for responsibilities of Local Maintaining Agencies.

Plan Content Requirements

In the Structures and/or Roadway Plans:

Show Pedestrian Railings on sidewalks and walls as required. Designate locations where handrails are required.

Include cross references to Design Standards Index 852 as appropriate.

When either Index 852 or 862 are acceptable, include cross references to both indexes and use Pay Item 515-2-1BB.

All Custom Infill Panels shall be fully detailed in the contract plans. A Custom Type Infill Panel Cell (00852-CTIP.cel) is available through the Structures CADD bar menu.

Prepare project specific Infill Panel details when required using the Pedestrian/Bicycle Railing Custom Infill Panel CADD cell and include the cell(s) in the plans. Designate each individual project specific Infill Panel with a unique name for identification and cross reference purposes.

Complete the following Data Tables and include them in the plans. See Introduction I.3 for more information regarding use of Data Tables.

In the HEIGHT column of the Data Table, enter either "42" for standard height railings or "54" for special height railings.

In the STYLE column of the Data Table, enter either "Type X" (where X = 1 thru 5 for the standard Infill Panel options) or "Custom" where custom Infill Panels are fully detailed in the plans.

STEEL PEDESTRIAN/BICYCLE RAILING DATA TABLES

PROJECT REQUIREMENTS					Table Date 01-01-11
Station to Station (Lt. or Rt.)	Height (in.)	Style Type (1)	Required: (Yes/No)		
			Bottle Guard	Colored Coatings (2)	Infill Panel to Reject Passage of 4" Sphere (Special conditions only)

- (1) For "CUSTOM" Style Types, see plans for in-fill panel details.
 (2) The color shall be per Federal Color Chart, Federal Standard No. 595B, Table _____, Color _____.

NOTES:
 1. Work this Data Table with Index No. 852.

STEEL PEDESTRIAN/BICYCLE RAILING CUSTOM TYPE INFILL PANEL DETAILS

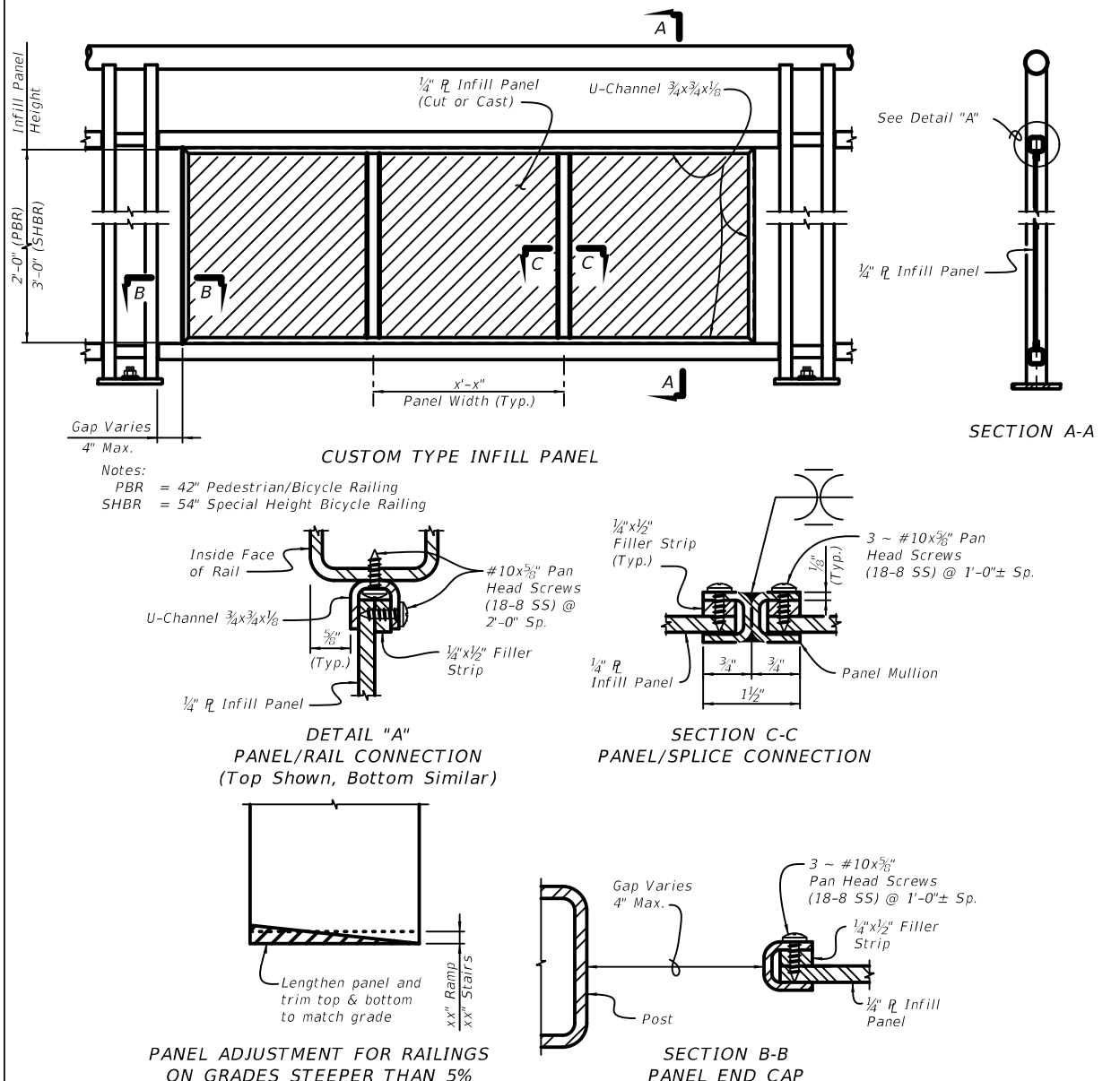

Payment

Item number	Item description	Unit Measure
515-2-1BB	Pedestrian / Bicycle Railing, Non Specified, 42" (Type___)	LF
515-2-1BB	Pedestrian / Bicycle Railing, Non Specified, 54" (Type___)	LF
515-2-2BB	Pedestrian / Bicycle Railing, Steel Only, 42" (Type___)	LF
515-2-2BB	Pedestrian / Bicycle Railing, Steel Only, 54" (Type___)	LF