

**LOWERING SYSTEM SPECIFICATIONS**

The lowering system shall consist of the following:

- A. Head frame and cover
- B. Luminaire ring
- C. Cables
- D. Winch
- E. Portable power unit (1 per project)

The head frame unit shall rigidly mate the top of the pole to the head frame platform. The platform with its associated sheaves, etc. shall be covered and raintight. The head frame structure shall be zinc coated steel, attached to the pole by means of a steel slipfitter. Head frame shall encompass six 6" nominal steel cable sheaves grooved to the exact cable diameter, for 180° cable bearing surface. The sheave shall be zinc electroplated to ASTM 164 and dipped in yellow chromate for corrosion resistance. Bearings and cable keepers shall have permanent lubrication. Three (3) stainless steel 7 x 19 aircraft cables of 3/16" or greater diameter shall be provided.

The pole cable shall be attached to the luminaire ring with a waterproof connector capable of withstanding the pull of the weight of the pole cable. Where the wire ropes are required to bend over sheaves or over the winch drum, the maximum working stress in the outer fibers of wire rope shall not exceed 20% of the wire rope manufacturer's rated ultimate stress.

Drum design shall cause level wind of wire rope. The power cord shall travel on sheave (s) or a combination of rollers providing a radius for the cord of 6" or larger. Each end of the sheave (s) or rollers shall have a keeper to prevent the cable from jumping out of the roller track.

The head frame shall also include three (3) latching devices to support the luminaire ring assembly when the lowering device is not in operation. The latches shall be actuated by alternate raising and lowering of the hoisting cables. Locking of luminaire ring shall be signaled by indicators visible from ground. All moving parts of the latch mechanism shall be serviceable from the ground. Each of the three latches shall be strong enough, by itself, to support twice the weight of the ring and all the luminaires. Latching mechanisms which depend primarily upon spring operation or contain dissimilar metals are not acceptable. The latching mechanism shall not require adjustment after the original installation.

The luminaire ring shall be constructed of a minimum of 6" x 2" x 7 gauge steel channel galvanized in accordance with ASTM A123 Class "B" steel channel with the appropriate number of 2" steel pipe mounting arms. The luminaire ring shall be prewired with Type "W" or specially reinforced Type "SD" power cable with suitable conductor quantity and size for proper operation and Type "ST" distribution wiring with insulation suitable for at least 105°C. All power cables should be attached to the aluminum weathertight wiring chamber with weathertight cable connectors. A 600 volt terminal block, completely prewired shall be included in the weathertight wiring chamber. A weather-tight twistlock power inlet shall be provided on the luminaire ring to allow testing of the luminaire while in the lowered position. The power inlet shall face away from the pole for easy access. Raising speed of the luminaire ring shall be a minimum of 12' per minute.

The ultimate support of the luminaire ring shall not be dependent upon the lowering and raising cables.

The system shall be provided with a circuit breaker assembly with a lightning arrester on the circuit breaker enclosure. A pigtail cord and receptacle shall be supplied from the circuit breaker assembly. The receptacle on the pigtail cord shall be of dead front construction. The receptacle shall have a push button pawl which screws the plug to the receptacle and when secure shall provide a NEMA 3R rating. The plug and receptacle shall be UL/CSA switch rated.

The winch shall be a reversible worm gear self locking type with an integral friction drag brake to prevent freespooling. The winch shall be designated for hand operation or for operation by means of a 1/2" heavy duty reversing electric drill motor, remote controlled to enable the operator to stand 25' from the pole, Stainless Steel 7 x 19 aircraft cables of 1/4" or greater diameter equal to MIL-W83420C shall be supplied on the winch. The winch shall be provided with keepers above the drum to force the cable away from the ends of the drum for spooling. The drum shall have a wire guard to prevent the cable from coming off.

The winch shall be mounted in such a way that the cable terminator and the riser cable connector may be reached and worked on by a person with his arm through the handhole.

Roller contact spring-loaded centering arms shall be provided to center the luminaire ring while ascending or descending the pole. The rollers for the centering arm shall be made of a water resistant nonmarking composition material. All axle shafts for arms and rollers shall be 304 stainless steel. The rollers shall be in contact with the pole at all times. The centering arms shall be interconnected and loaded with stainless steel springs to uniformly apply equal centering force from the arms.

**LUMINAIRE SPECIFICATIONS**

The reflector with its aluminum cover shall be firmly attached to a cast ring. This ring shall have keyhole slots in its upper surface such that the reflector/refractor assembly may be readily attached to, or detached from, the luminaire bracket entry and lamp support assembly without completely removing the support bolts.

Each luminaire shall contain an integral auto-regulator type ballast connected for 480 volts input + 10% and a power factor of more than 90%. The luminaire ballast shall be enclosed within an aluminum housing which integrally attaches to the luminaire bracket entry and lamp support assembly. It shall be readily removable without removing the luminaire from the bracket arm.

The luminaire shall be attached to the bracket arm by means of a bracket entry and lamp support assembly. The assembly shall include a side entry slipfitter designed for 2" pipe with provision for 3° adjustment for leveling the luminaire. An enclosed terminal block shall be included such that all electrical connections shall be protected from exposure to weather.

All electrical connections shall be made waterproof or be made inside a weather resistant enclosure. All luminaires shall be ANSI/IES light distribution as indicated in plans. Each luminaire shall be labeled with a permanent label which states the type of lamp, voltage input, power input, power factor, ballast type, socket position, ANSI/IES light distribution, and such other catalog information that a complete replacement can be readily ordered.

The contractor's attention is directed to those plan sheets detailing the mounting of luminaires at the pole top. Particular attention is directed to alignment of luminaire light distributions. Special attention must be exercised in the physical alignment of these luminaires to ensure that the approved photometric layout is physically produced at each lighting standard in the field. A marking shall be placed on the external face of the refractor to allow visual inspection of alignment. The marking shall correspond to the 0° axis of the refractor.

**LOWERING SYSTEM AND LUMINAIRE SPECIFICATIONS**



2006 Interim Design Standard	
<b>HIGHMAST LIGHTING</b>	

Interim Date 07/01/07	Sheet No. 1 of 7
Index No. <b>17502</b>	

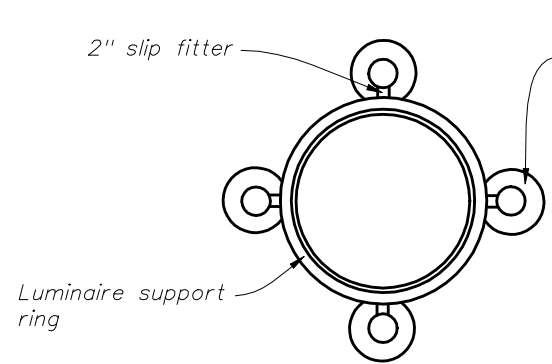

See legend for number of luminaires, lamp wattage and light distribution.

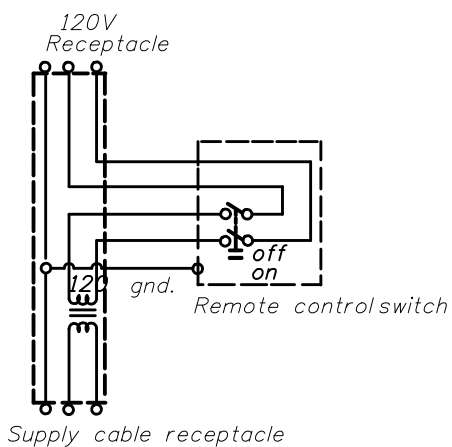
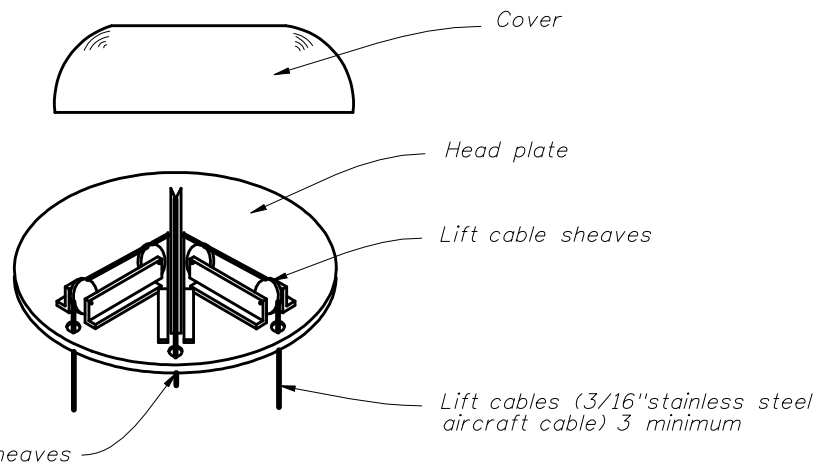

SCHEMATIC OF REMOTE AUXILIARY POWER UNIT

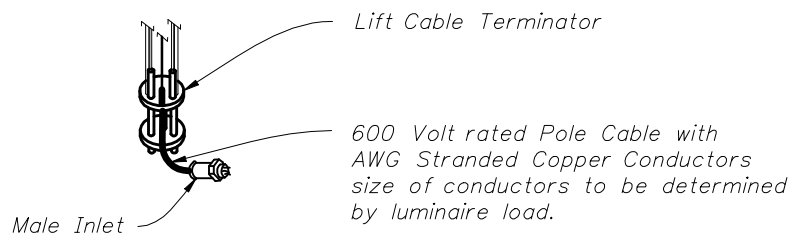
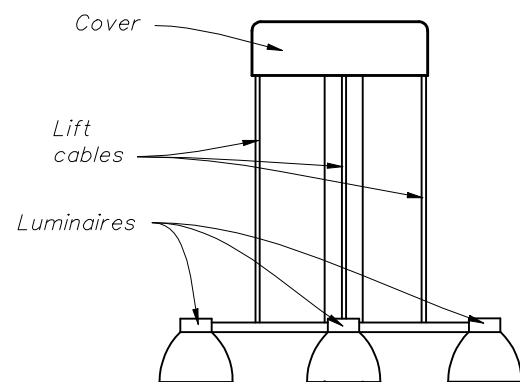

Spring supported centering arms provided to center the luminaire ring.

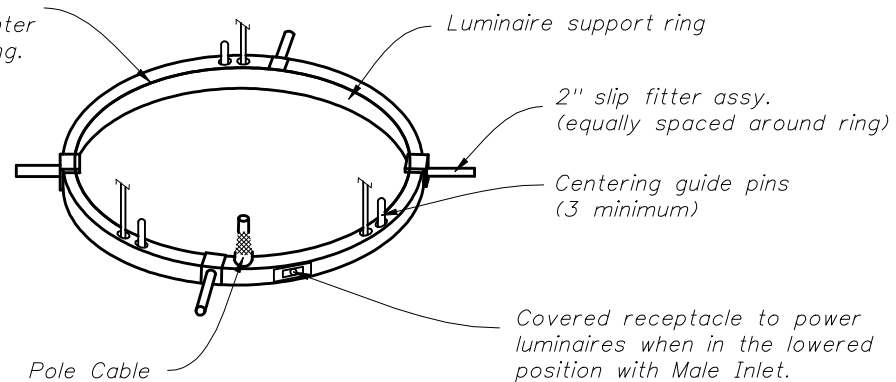

5/8" hex drive 3/4" round shaft

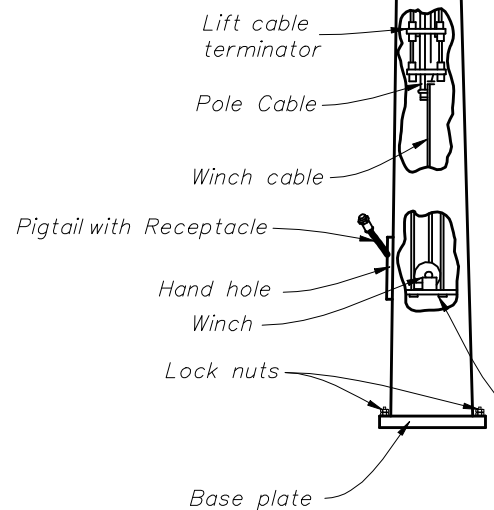
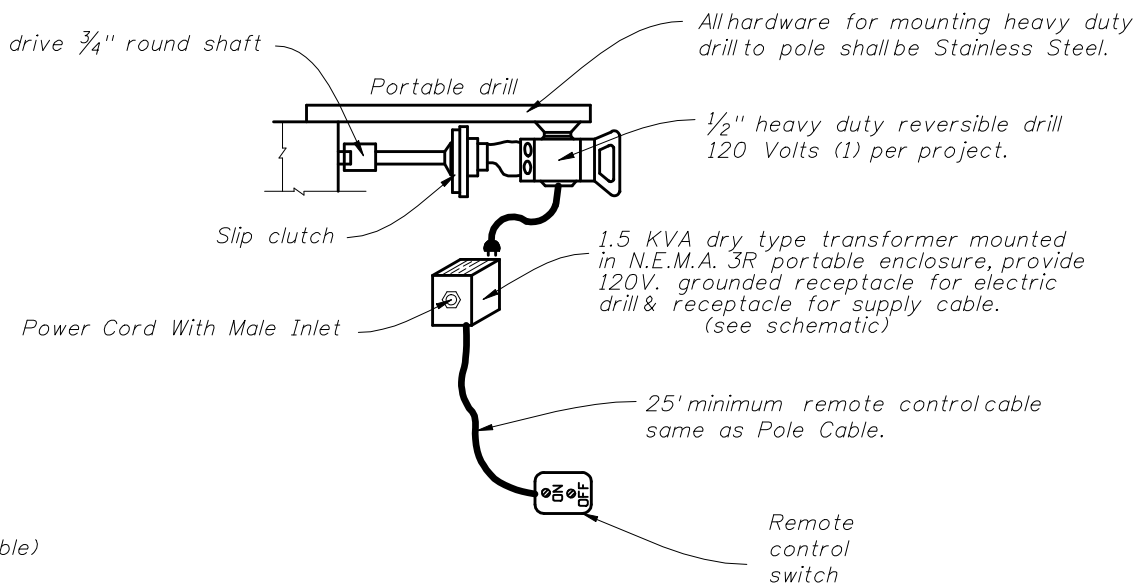

High mast pole

Positive drive reversible winch. The complete enclosed drum gear shall directly mesh with the worm gear train, in the same enclosure.

A surge protector shall be located in the pole with the circuit breaker. The surge protector shall be mounted at the front near hand hole for easy access.

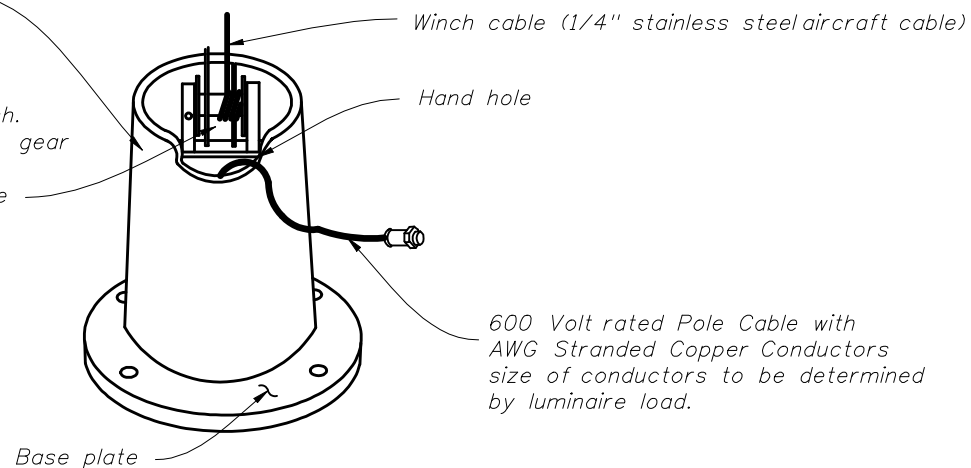

LOWERING DETAILS



2006 Interim Design Standard

HIGHMAST LIGHTING

Interim Date	Sheet No.
07/01/07	2 of 7
Index No.	
17502	

**HIGHMAST LIGHTING NOTES:**

- 1) High Mast materials:
  - a. Pole: ASTM A1011 Grade 50, 55, 60 or 65 (Less than 1/4") or ASTM A572 Grade 50, 55, 60, or 65 (1/4" and over) or ASTM A595 Grade A (55 ksi yield) or Grade B (60 ksi yield).
  - b. Steel Plates: ASTM A709 Grade 36 or ASTM A36
  - c. Weld Metal: E70XX
  - d. Anchor Bolts: ASTM F1554 Grade 55 with ASTM A563, Grade A heavy-hex nuts and ASTM F436 Type I washers.
  - e. Handhole: ASTM A709 Grade 36 or ASTM A36 Frame with ASTM A36 cover.
  - f. Caps: ASTM A1011 Grade 50, 55, 60 or 65 or ASTM B209.
  - g. Nut Covers: ASTM B26 (319-F)
  - h. Stainless Steel Screws: AISI Type 316
- 2) Reinforcing steel: ASTM A615, Grade 60.
- 3) Concrete: Class IV (Drilled Shaft) with a minimum 4,000 psi compressive strength at 28 days for all environmental classifications.
- 4) Grout: minimum 5,000 psi compressive strength at 28-days and meeting the requirements of Section 934.
- 5) Welding: American Welding Society Structural Welding Code (Steel) ANSI/AWS D1.1 (Current edition).
- 6) Galvanization:
  - a. Nuts, Bolts, Washers and Threaded Bars/Studs: ASTM F2329.
  - b. Other items (Including Pole): ASTM A123
- 7) Hole diameters for anchor bolts: not greater than the bolt diameter plus 1/2".
- 8) Poles: Tapered with the diameter changing at a rate of 0.14 inch per foot with a minimum 16-sided pole shaft and only one longitudinal seam weld. Circumferentially welded pole shaft butt splices and laminated pole shafts are not permitted. Longitudinal seam welds within 6 inches of pole to base must be complete penetration welds. Longitudinal seam welds at telescopic field joints must be complete penetration welds for the splice length plus 6 inches.
- 9) If a grout pad is not installed, place wire cloth screen vertically between the base plate and top of foundation, wrap horizontally around the base plate with a 3" min. lap. Use standard grade, plain weave, 2x2 mesh, galvanized steel wire-cloth with 0.063" dia. wire. Attach the screen to the base plate with stainless steel self-tapping 1/4" screws with stainless steel washers spaced at 9" centers.
- 10) Manufacturers seeking approval of a Highmast Lighting assembly for inclusion on the Qualified Products List must submit a QPL Production Evaluation Application along with drawings showing the product meets all specified requirements of this Index.

**DESIGN CRITERIA:**

- 1) Designed in accordance with the FDOT Structures Manual.
- 2) Poles are designed to support the following:
  - a. (1) cylindrical head assembly with a maximum effective projected area of 6 Sq. ft. (Cd=1) and 340 lbs (Max).
  - b. (8) cylindrical luminaires with a maximum effective projected area of 3.0 Sq. ft (Cd=0.5) and 77 lbs. each.
- 3). Foundation design based upon the following soil criteria:
  - Classification = Cohesionless (Fine Sand)
  - Friction Angle = 30 Degrees (30°)
  - Unit Weight = 50 lbs./cu. Ft. (assumed saturated)

Only in cases where the Designer considers the soil types at the specific site location to be of lesser strength properties should an analysis be required. Auger borings, SPT borings or CPT soundings may be utilized as needed to verify the assumed soil properties, and at relatively uniform sites, a single boring or sounding may cover several foundations. Furthermore, borings in the area that were performed for other purposes may be used to confirm the assumed soil properties.
- 4) Foundation applies only to slopes of 1:4 or flatter. Provide a minimum 24" shaft projection on the high side.
- 5) Poles are designed for 6 mil galvanization thickness.

**STANDARD POLE DESIGN NOTES**

**REVISIONS**

DATE	BY	DESCRIPTION	DATE	BY	DESCRIPTION
07/01/07	DYW	AASHTO 2001 LTS-4 Specifications update. Designed new Standard Highmast Assemblies.			

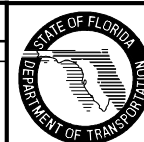

2006 Interim Design Standard

**HIGHMAST LIGHTING**

Interim Date	Sheet No.
07/01/07	3 of 7
Index No.	
<b>17502</b>	

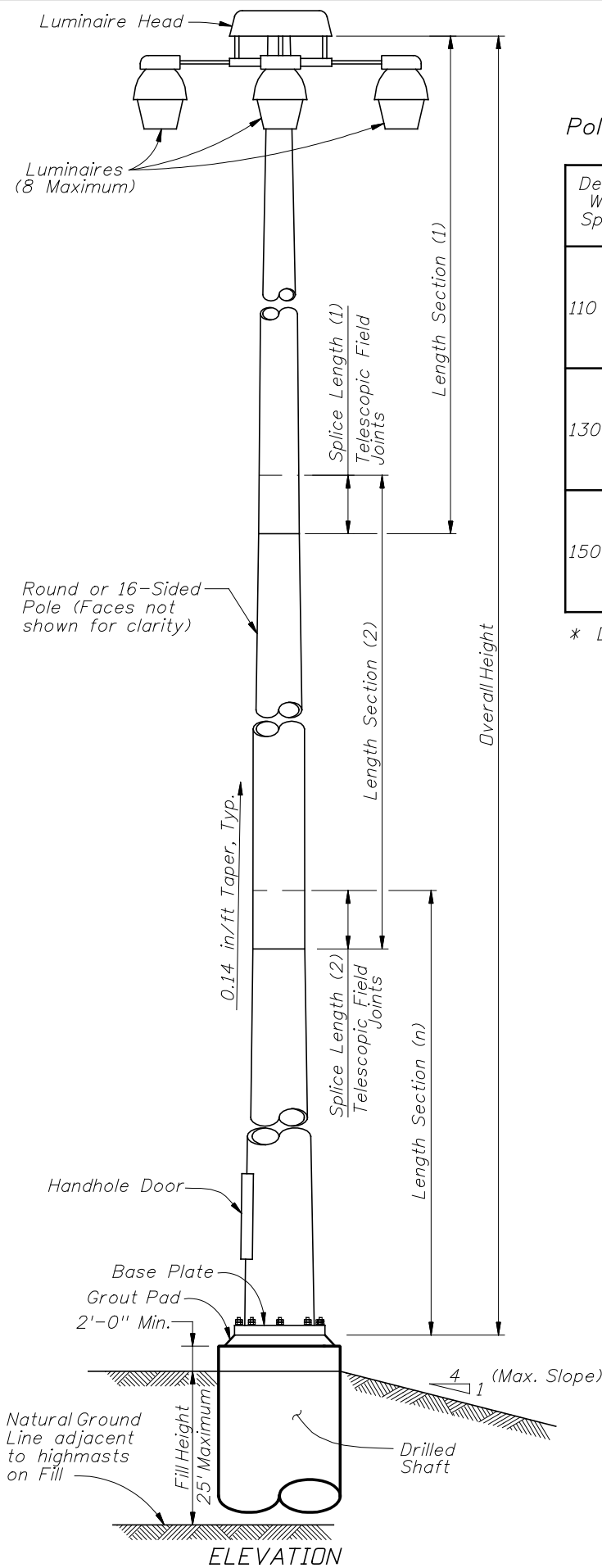

Pole Design Table\*

Design Wind Speed	Pole Overall Height	Section 1 (Top)					Section 2					Section 3				
		Length.	Wall Th.	Minimum Splice L.	Tip Dia.	Base Dia.	Length.	Wall Th.	Minimum Splice L.	Tip Dia.	Base Dia.	Length.	Wall Th.	Minimum Splice L.	Tip Dia.	Base Dia.
110 mph	80 ft	42'-0"	0.250"	2'-0"	5.313"	11.219"	40'-0"	0.250"	---	10.375"	16.000"	---	---	---	---	---
	100 ft	24'-6"	0.179"	2'-0"	6.406"	9.844"	40'-0"	0.250"	2'-6"	9.188"	14.781"	40'-0"	0.250"	---	13.875"	19.500"
	120 ft	44'-9"	0.250"	2'-0"	6.250"	12.531"	40'-0"	0.250"	2'-9"	11.688"	17.313"	40'-0"	0.313"	---	16.375"	22.000"
130 mph	80 ft	42'-0"	0.250"	2'-0"	5.281"	11.188"	40'-0"	0.313"	---	10.375"	16.000"	---	---	---	---	---
	100 ft	24'-6"	0.179"	2'-0"	6.906"	10.344"	40'-0"	0.250"	2'-6"	9.656"	15.281"	40'-0"	0.313"	---	14.375"	20.000"
	120 ft	45'-6"	0.250"	2'-6"	9.250"	15.625"	40'-0"	0.250"	3'-0"	14.719"	20.344"	40'-0"	0.313"	---	19.375"	25.000"
150 mph	80 ft	42'-3"	0.250"	2'-3"	7.281"	13.219"	40'-0"	0.313"	---	12.375"	18.000"	---	---	---	---	---
	100 ft	24'-6"	0.250"	2'-0"	8.188"	11.625"	40'-0"	0.313"	2'-6"	10.781"	16.406"	40'-0"	0.375"	---	15.375"	21.000"
	120 ft	46'-6"	0.250"	3'-0"	12.406"	18.938"	40'-0"	0.313"	3'-6"	17.938"	23.563"	40'-0"	0.375"	---	22.375"	28.000"

\* Diameter Measured Flat to Flat

Base Plate and Bolts Design Table

Design Wind Speed.	Pole Overall Height	Base Plate Diameter	Base Plate Thickness	"TW"	"BW"	Bolt Circle	No. Bolts	Bolt Diameter	Bolt Embedment
110 mph	80 ft	30.0"	2.000"	0.375"	0.188"	23.0"	8	1.75"	38"
	100 ft	33.5"	2.375"	0.375"	0.188"	26.5"	8	1.75"	42"
	120 ft	36.0"	2.625"	0.375"	0.250"	29.0"	8	1.75"	45"
130 mph	80 ft	30.0"	2.375"	0.438"	0.250"	23.0"	8	1.75"	43"
	100 ft	34.0"	2.750"	0.438"	0.250"	27.0"	8	1.75"	50"
	120 ft	41.0"	3.125"	0.500"	0.250"	33.0"	8	2.00"	52"
150 mph	80 ft	32.0"	2.625"	0.500"	0.250"	25.0"	8	1.75"	49"
	100 ft	37.0"	3.000"	0.563"	0.313"	29.0"	8	2.00"	53"
	120 ft	46.0"	3.250"	0.563"	0.313"	37.0"	10	2.25"	57"

Shaft Design Table

Design Wind Speed.	Pole Overall Height	Shaft Diameter	Shaft Length	Longitudinal Reinforcement
110 mph	80 ft	4'-0"	13'-0"	16 - # 10
	100 ft	4'-0"	15'-0"	16 - # 10
	120 ft	4'-6"	16'-0"	20 - # 10
130 mph	80 ft	4'-0"	14'-0"	16 - # 10
	100 ft	4'-0"	16'-0"	16 - # 10
	120 ft	4'-6"	18'-0"	20 - # 10
150 mph	80 ft	4'-0"	16'-0"	16 - # 10
	100 ft	4'-6"	17'-0"	20 - # 10
	120 ft	5'-0"	20'-0"	24 - # 10

POLE DESIGN TABLES

REVISIONS

DATE	BY	DESCRIPTION	DATE	BY	DESCRIPTION
07/01/07	DYW	AASHTO 2001 LTS-4 Specifications update. Designed new Standard Highmast Assemblies.			

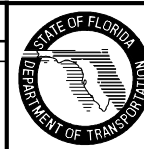

2006 Interim Design Standard

HIGHMAST LIGHTING

Interim Date

07/01/07

Sheet No.

4 of 7

Index No.

17502

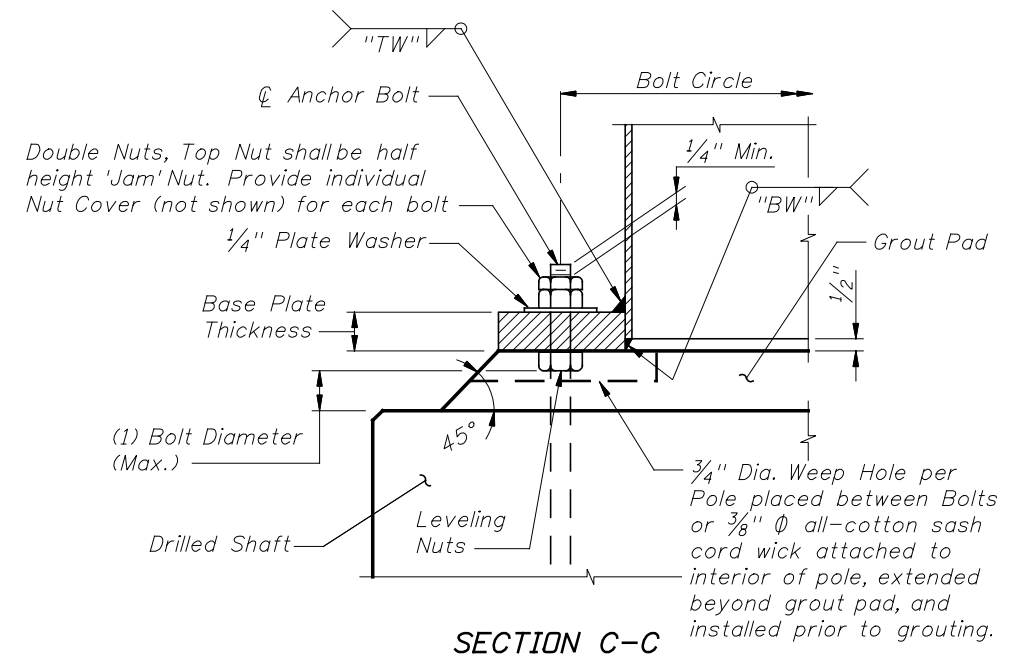
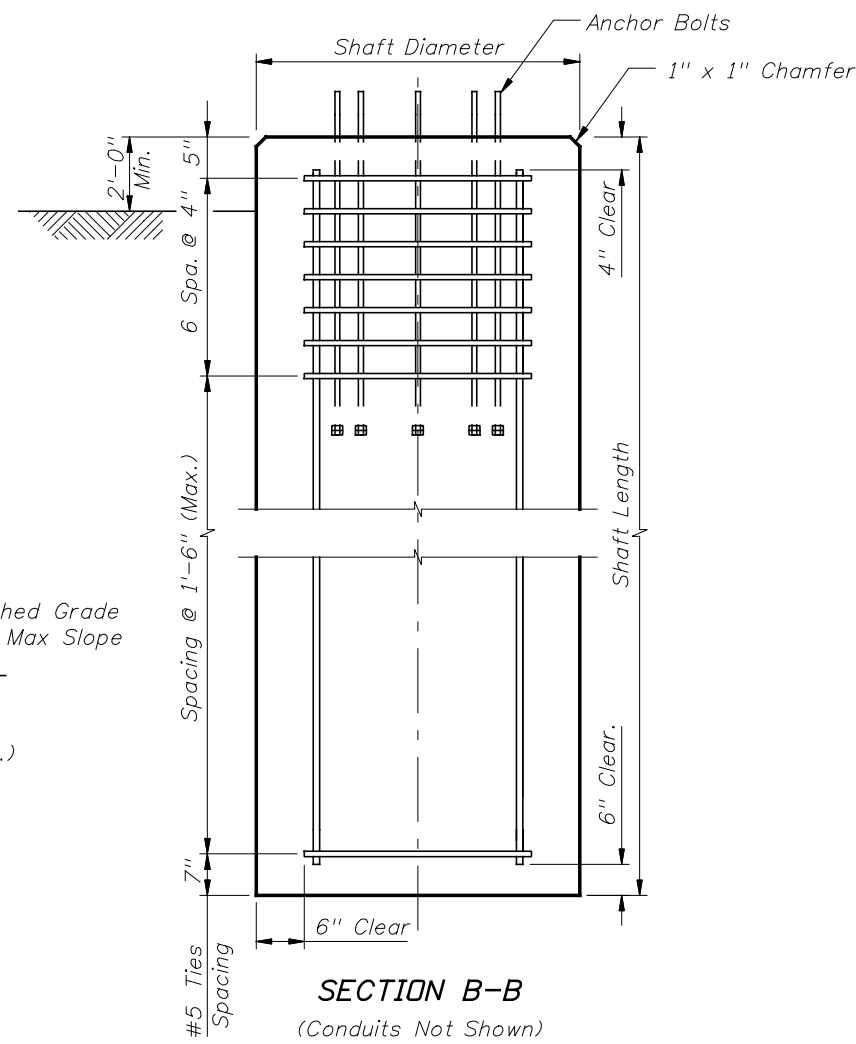
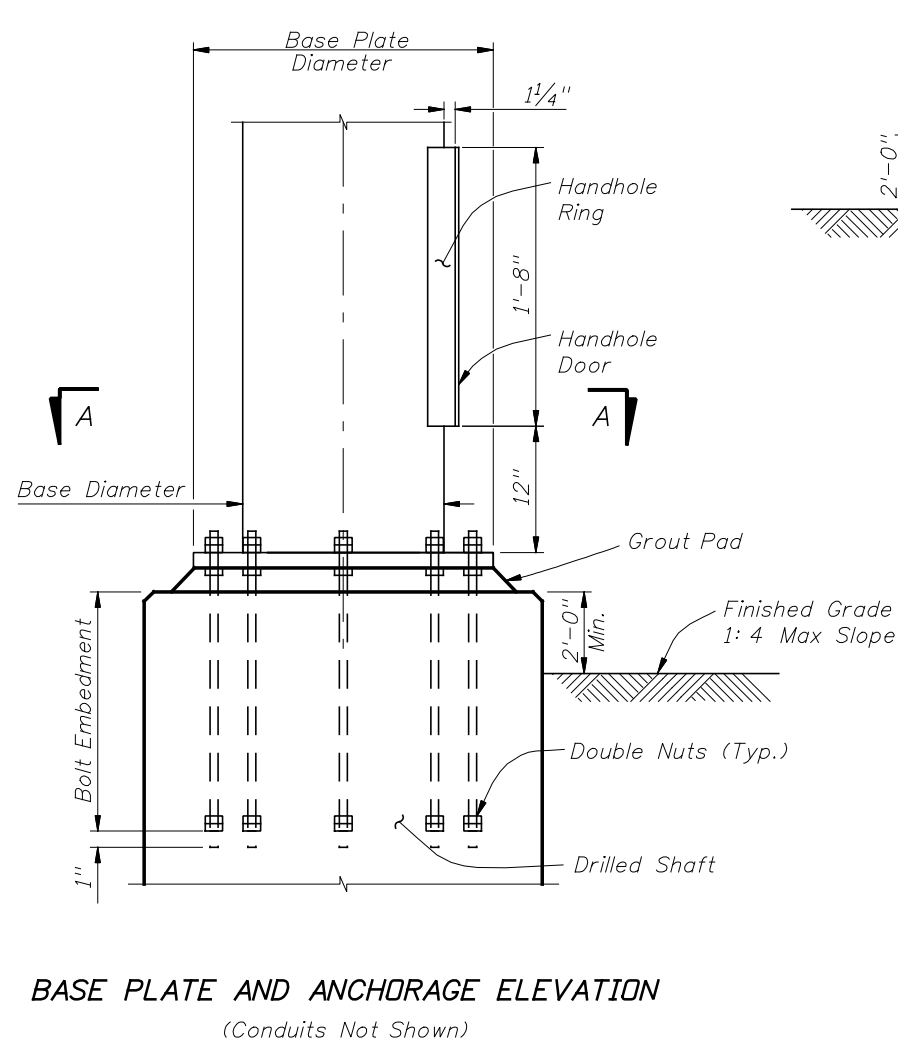
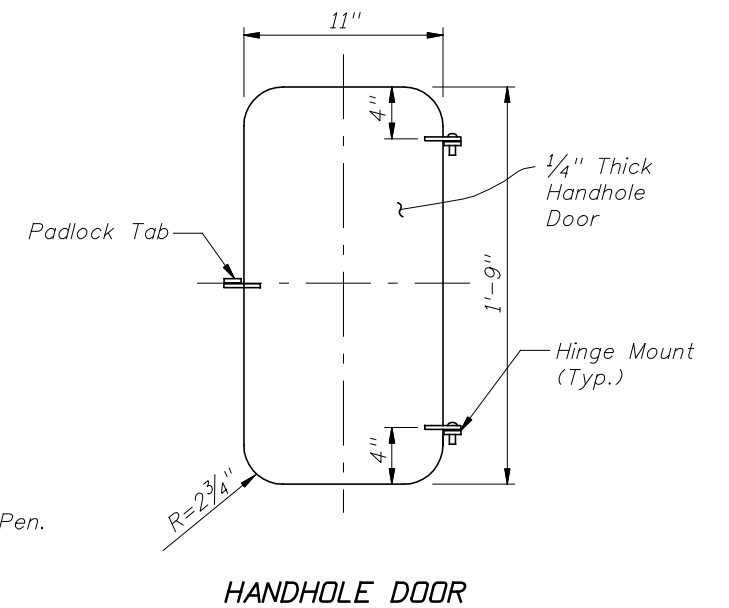
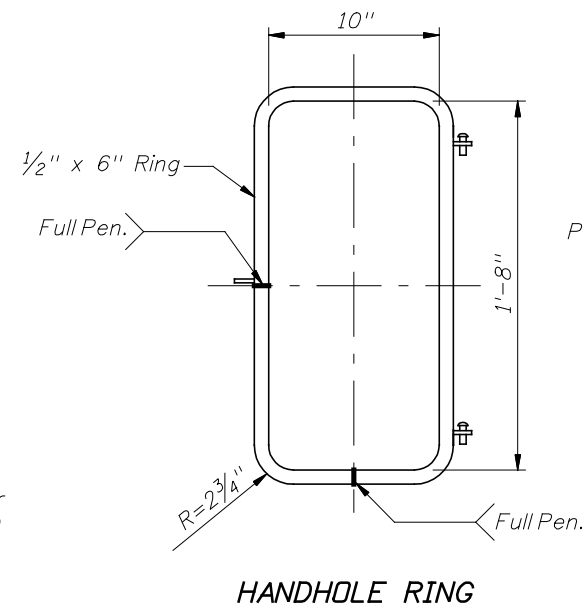
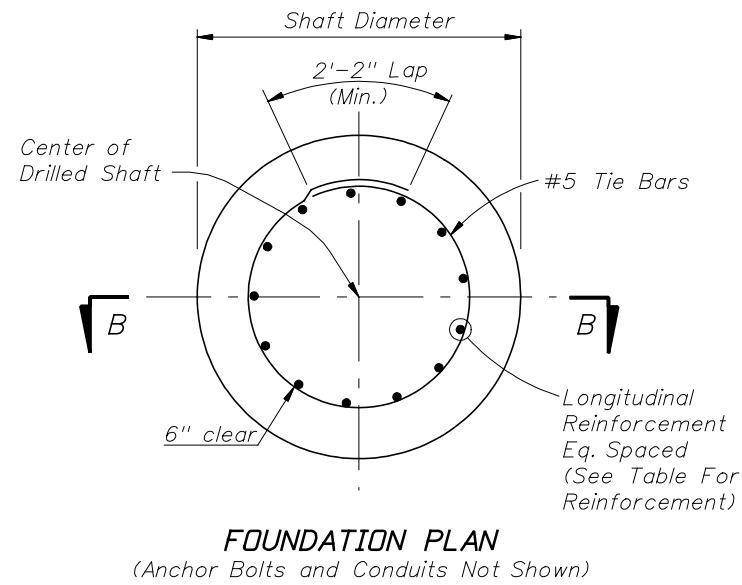
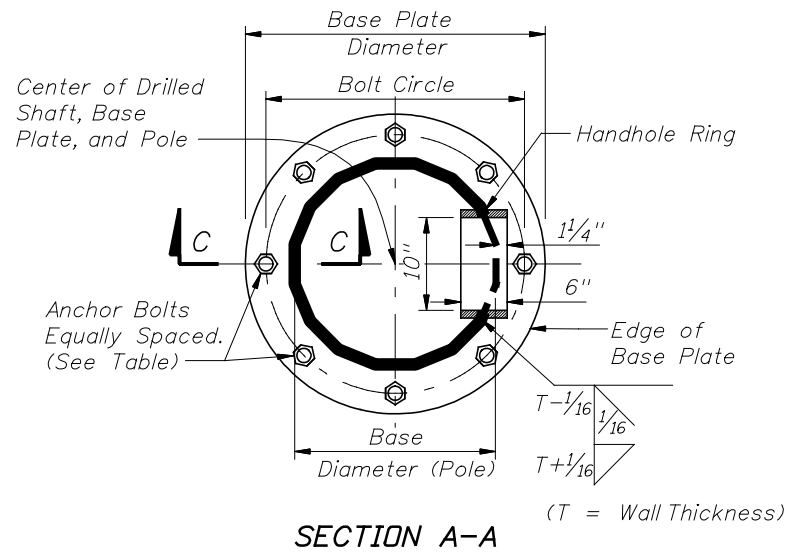

**POLE FOUNDATION**

REVISIONS			
DATE	BY	DESCRIPTION	
07/01/07	DYW	AASHTO 2001 LTS-4 Specifications update. Designed new Standard Highmast Assemblies.	

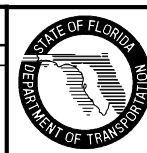

2006 Interim Design Standard

**HIGHMAST LIGHTING**

Interim Date	Sheet No.
07/01/07	5 of 7
Index No.	
17502	

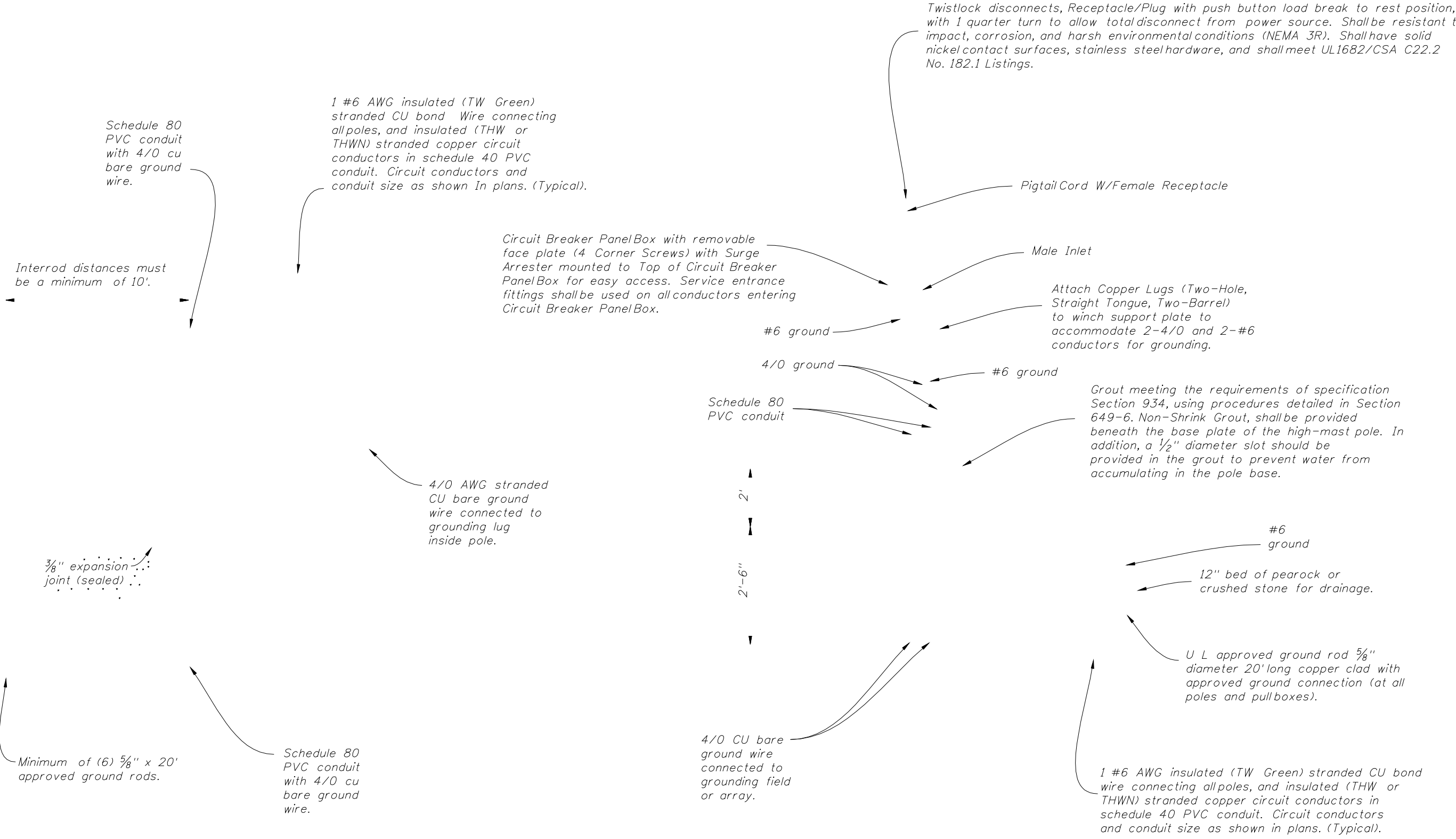

Twistlock disconnects, Receptacle/Plug with push button load break to rest position, with 1 quarter turn to allow total disconnect from power source. Shall be resistant to impact, corrosion, and harsh environmental conditions (NEMA 3R). Shall have solid nickel contact surfaces, stainless steel hardware, and shall meet UL1682/CSA C22.2 No. 182.1 Listings.

Schedule 80 PVC conduit with 4/0 CU bare ground wire.

1 #6 AWG insulated (TW Green) stranded CU bond Wire connecting all poles, and insulated (THW or THWN) stranded copper circuit conductors in schedule 40 PVC conduit. Circuit conductors and conduit size as shown in plans. (Typical).

Interrod distances must be a minimum of 10'.

Circuit Breaker Panel Box with removable face plate (4 Corner Screws) with Surge Arrester mounted to Top of Circuit Breaker Panel Box for easy access. Service entrance fittings shall be used on all conductors entering Circuit Breaker Panel Box.

Pigtail Cord W/Female Receptacle

Male Inlet

Attach Copper Lugs (Two-Hole, Straight Tongue, Two-Barrel) to winch support plate to accommodate 2-4/0 and 2-#6 conductors for grounding.

#6 ground

#6 ground

4/0 ground

Schedule 80 PVC conduit

Grout meeting the requirements of specification Section 934, using procedures detailed in Section 649-6. Non-Shrink Grout, shall be provided beneath the base plate of the high-mast pole. In addition, a 1/2" diameter slot should be provided in the grout to prevent water from accumulating in the pole base.

4/0 AWG stranded CU bare ground wire connected to grounding lug inside pole.

3/8" expansion joint (sealed)

#6 ground

12" bed of pearrock or crushed stone for drainage.

U L approved ground rod 5/8" diameter 20' long copper clad with approved ground connection (at all poles and pull boxes).

Minimum of (6) 5/8" x 20' approved ground rods.

Schedule 80 PVC conduit with 4/0 CU bare ground wire.

4/0 CU bare ground wire connected to grounding field or array.

1 #6 AWG insulated (TW Green) stranded CU bond wire connecting all poles, and insulated (THW or THWN) stranded copper circuit conductors in schedule 40 PVC conduit. Circuit conductors and conduit size as shown in plans. (Typical).

NOTES:

1. At all pull boxes and pole bases, ends of conduit shall be sealed in accordance with Section 630 of the Standard Specifications For Road And Bridge Construction.
2. Slabs to be placed around all Poles and Pull Boxes.
3. For Pull Boxes between Poles refer to Index 17500.



• Interim Design Standard  
**HIGHMAST LIGHTING**

WIRING DETAILS

Interim Date  
**07/01/07 6 of 7**

**17502**