

---

## Index 18113 Concrete CCTV Pole

### ORIGINATION

**Date:** 7/27/17

**Name:** Derwood Sheppard

**Phone:** (850) 414-4334

**Email:** Derwood.Sheppard@dot.state.fl

### COMMENTARY

All Sheets: Redeveloped Index.

Consolidated relevant information from Indexes 18100, 18101, 18102, 18104, 18105, 18107, and 18108, which were deleted for the Standards Plans for the FY 2018-19 release.

### COMMENTS AND RESPONSES

**BLACK** = Industry Review Comments    **RED** = Standard Plans Response

**Name:** Katie King, P.E.

**Date:** Thursday, September 14, 2017 10:17 AM

#### **COMMENT:**

Sheet 5 of 5 – There are duplicate “Conduit Entry Hole” tags in the ground mount cabinet detail on the bottom left of the sheet. One says to SEE SHEET 5 and the other says SEE SHEET 3. The SEE SHEET 5 one should be removed.

#### **RESPONSE:**

**Date:** 9/19/17

Agreed, Change Made.

**GENERAL NOTES:**

1. Work this Index with Specifications 641.
2. This Index is considered fully detailed and no shop drawings are necessary. Submit Shop Drawings for minor modifications not detailed in the Plans.
3. Install pole plumb.
4. Provide either round or 12-sided Poles.
5. See Index 635-001 for additional details for Pull Boxes.
6. Materials:
  - A. Pole: Use Class VI concrete with 6 ksi minimum strength at transfer.
  - B. Prestressing Strands: ASTM A416, Grade 270 low relaxation.
  - C. Reinforcing Steel: ASTM A615, Grade 60
  - D. Spiral Reinforcing: ASTM A1064 Cold-Drawn
  - E. Bolts: ASTM F1554, Grade 55  
Nuts: ASTM A563, Grade A Heavy Hex  
Washers: ASTM F436
  - F. Steel plates and Pole Cap: ASTM A36 or ASTM A709, Grade 50
  - G. Galvanization: Bolts, nuts and washers : ASTM F2329  
All other steel: ASTM A123
7. Pole Fabrication:
  - A. Cut the tip end of the prestressed strand first or simultaneously with the butt end.
  - B. For spiral reinforcing, one turn is required for spiral splices and two turns are required at the top and bottom of poles.
  - C. For Reinforcing Steel, lap splice to consist of a 3'-0" lap length at each splice. No more than two opposing rebar to be spliced at the same cross section. Stagger lap splices as needed.
  - D. Provide a Class 3 surface finish in accordance with Specification 400.
  - E. Provide a 1" minimum cover.
  - F. Provide handhole and coupler cover plates made of non-corrosive materials. Attach cover plates to poles using lead anchors or threaded inserts embedded in the poles in conjunction with round headed chrome plated screws.
  - G. Provide Identification Markings on the poles where indicated on the following sheets. Include the following information using inset numerals with 1" height or as approved in the Producers' Quality Control Program:  
  
Financial Project ID  
Pole Manufacturer  
Pole Length
  - H. Tie ground wires to the interior of reinforcing steel as necessary to prevent displacement during concreting operations.
  - I. Storage, Handling and Erection locations shown may vary within  $\pm 3"$ .
8. Cabinet Installation:
  - A. Splice fiber optic cables in cabinet to preterminater patch panel.
  - B. Furnish and install TVSS protection on all cabling in cabinet.
  - C. Furnish and install secondary TVSS protection on outlets for equipment in cabinet.
  - D. Ensure that all electronic equipment power is protected and conditioned with TVSS devices.
  - E. Ensure that equipment cabinet is bonded to CCTV pole grounding system.
  - F. Install the pole mounted cabinet with the hinges next to the pole.
  - G. Sizes and types of conduits and innerducts for network communications between the pullbox and cabinet are stated in the Contract Documents.
9. Lowering Device Installation:
  - A. Place the lowering cable that moves within the pole in an interior conduit to prevent it from tangling or interfering with any electrical wire that is in the pole. Ensure that any electrical wire within the pole is routed securely and free from slack.
  - B. Mount lowering arm perpendicular to the roadway or as shown in the plans. Position CCTV pole so that the camera can be safely lowered without requiring lane closures.
  - C. Coordinate all lowering device hardware requirements (including Tenon, Tenon mounting plates, parking stand, etc.) with lowering device manufacturer.

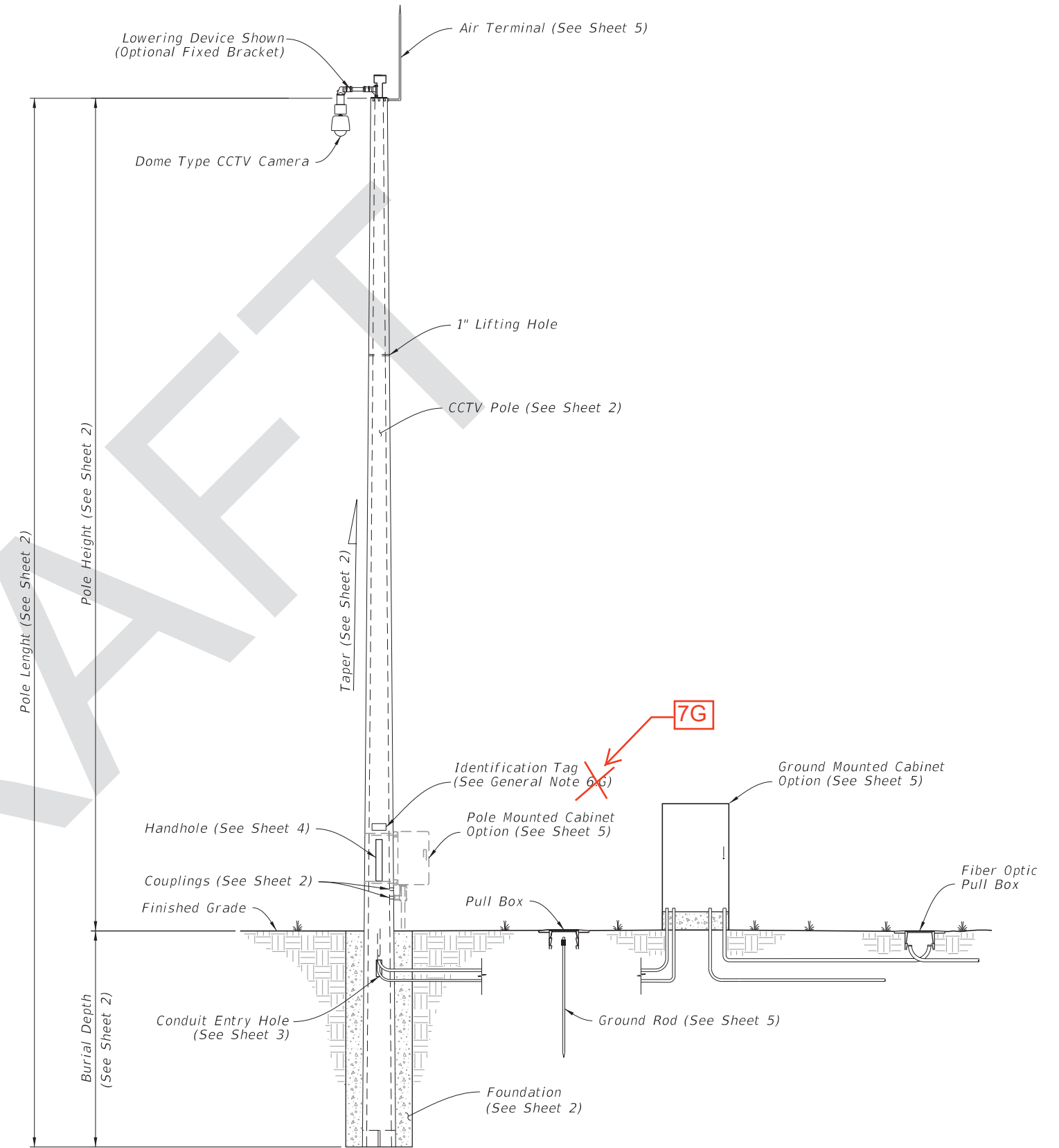

CCTV POLE ASSEMBLY

8/22/2017 11:37:19 AM

LAST REVISION 11/01/17	REVISION	DESCRIPTION:	 FY 2018-19 STANDARD PLANS	CONCRETE CCTV POLE	INDEX 641-020	SHEET 1 of 5
---------------------------	----------	--------------	---	--------------------	------------------	-----------------

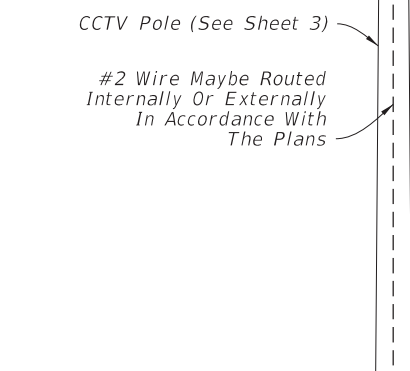
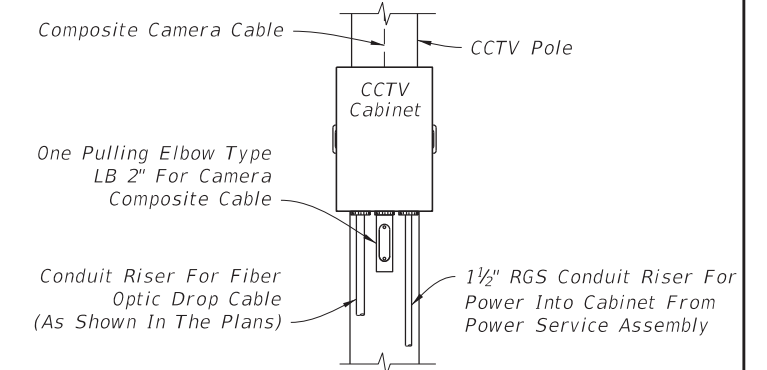
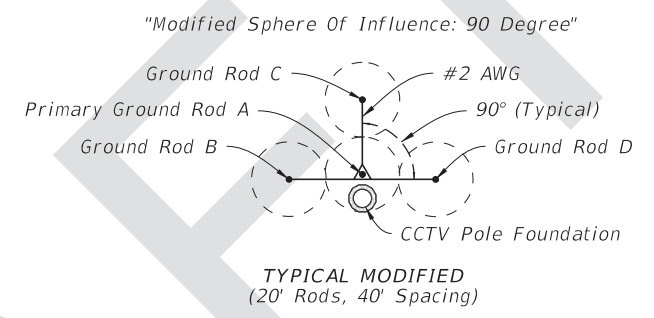
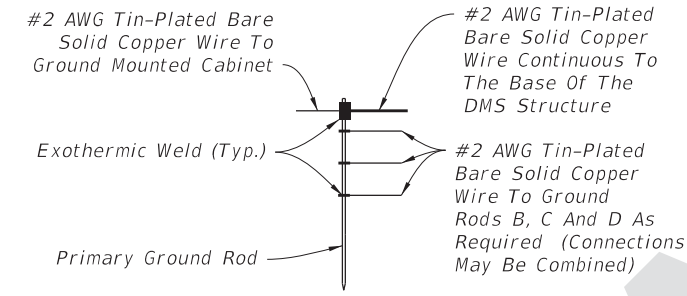
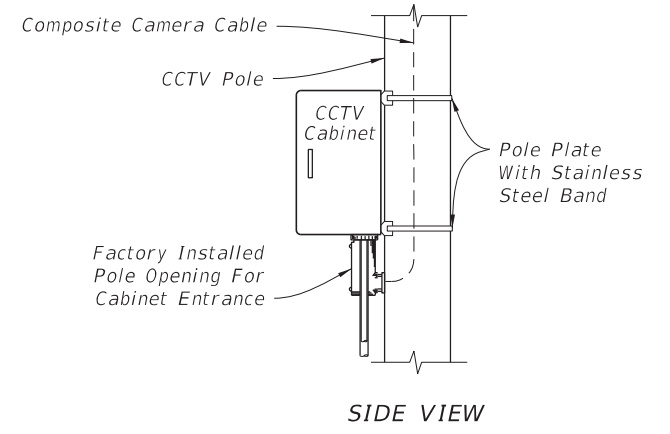
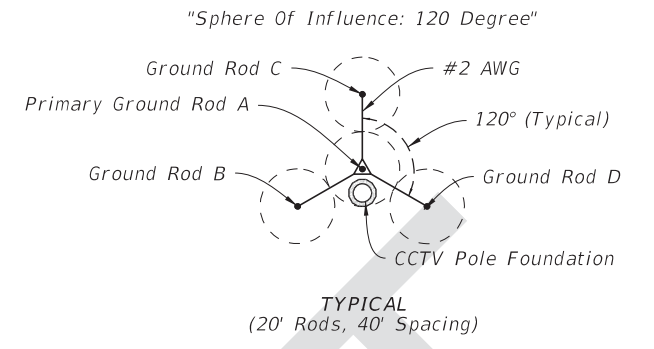
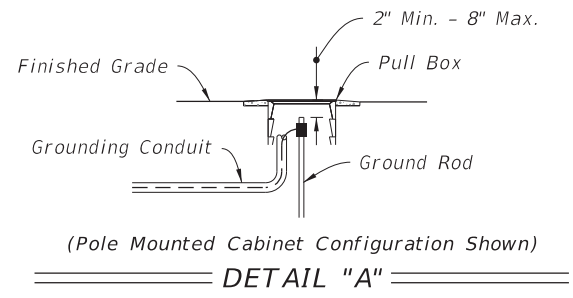
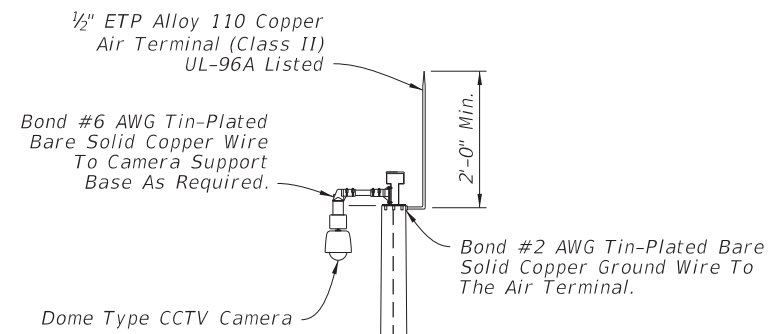

GROUND ROD ARRAY PLACEMENT

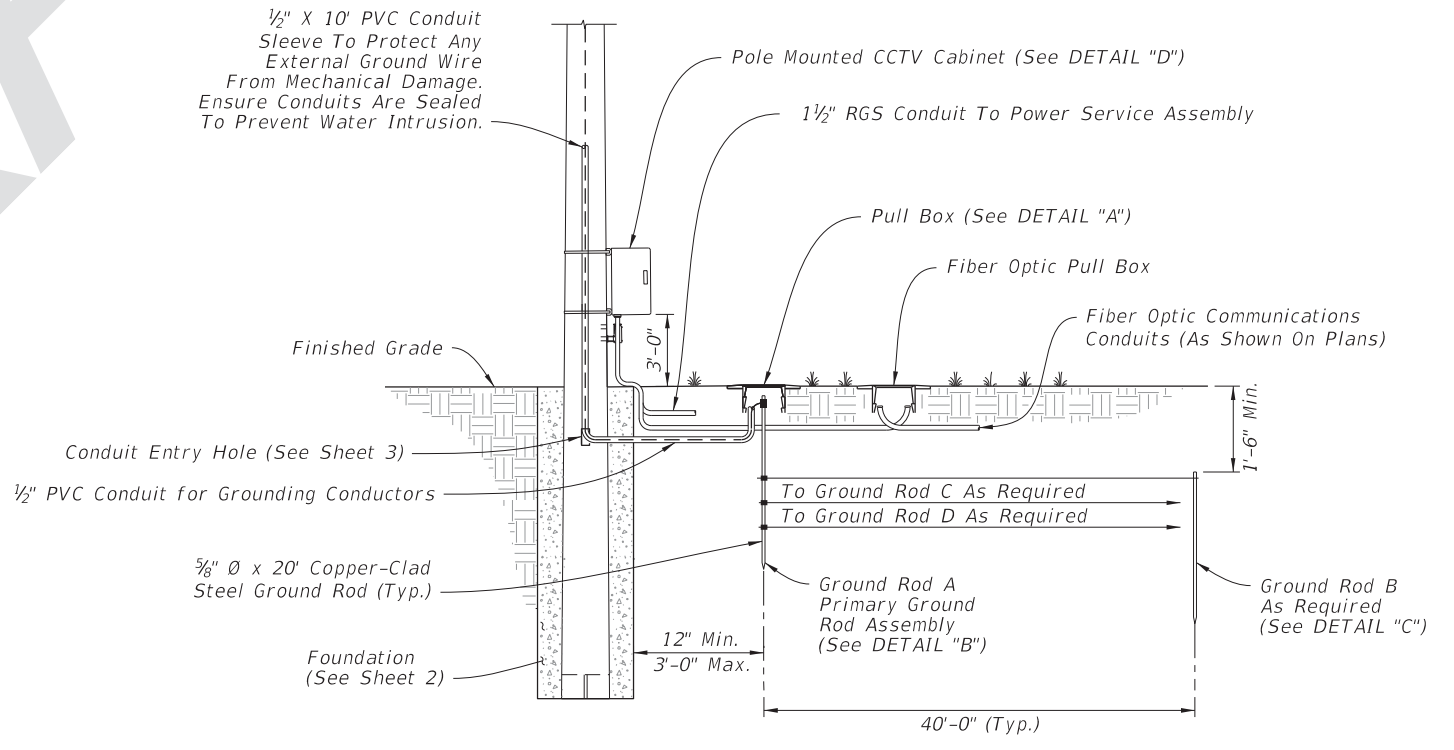
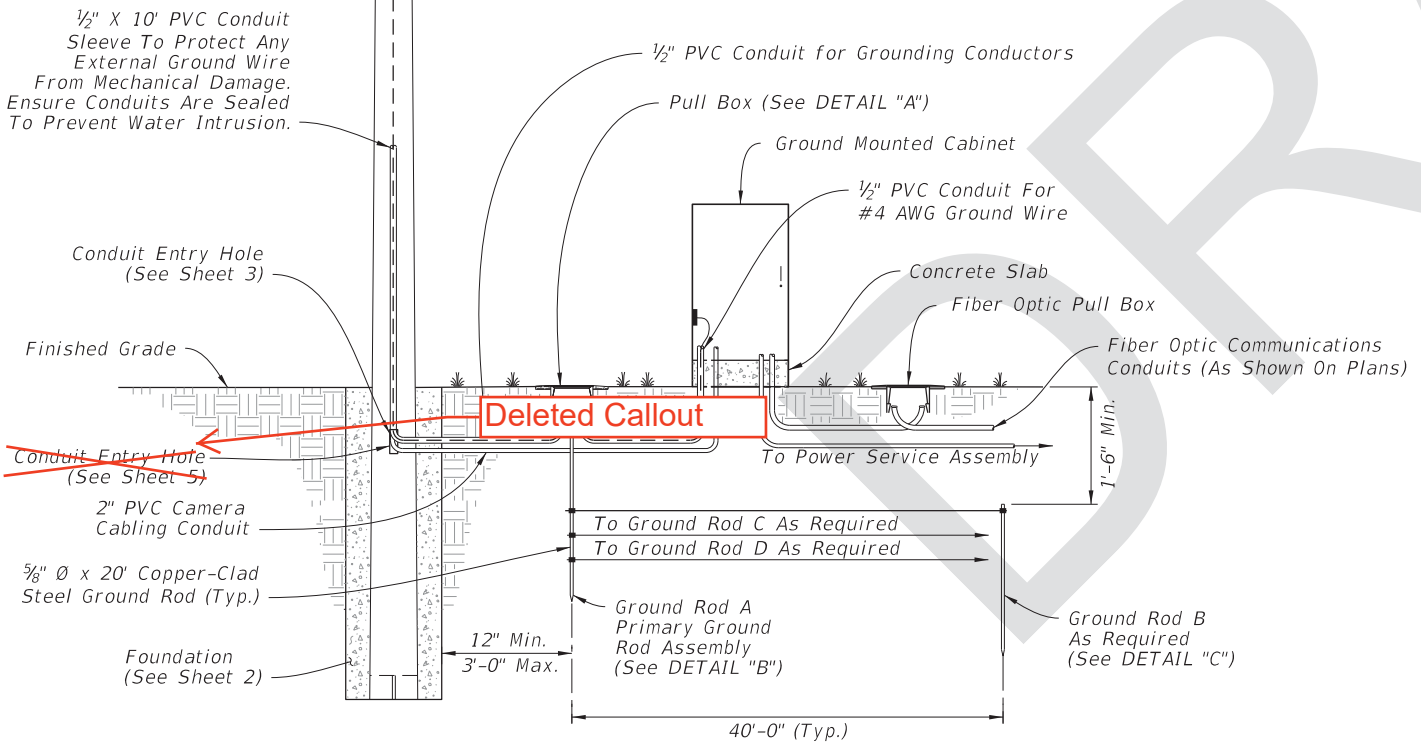

CONCRETE CCTV POLE GROUNDING

8/22/2017 11:37:21 AM

LAST REVISION	11/01/17	DESCRIPTION:	FY 2018-19 STANDARD PLANS	CONCRETE CCTV POLE	INDEX	SHEET
					641-020	5 of 5

**GENERAL NOTES:**

1. Work this Index with Specifications 641.
2. This Index is considered fully detailed and no shop drawings are necessary. Submit Shop Drawings for minor modifications not detailed in the Plans.
3. Install pole plumb.
4. Provide either round or 12-sided Poles.
5. See Index 635-001 for additional details for Pull Boxes.
6. Materials:
  - A. Pole: Use Class VI concrete with 6 ksi minimum strength at transfer.
  - B. Prestressing Strands: ASTM A416, Grade 270 low relaxation.
  - C. Reinforcing Steel: ASTM A615, Grade 60
  - D. Spiral Reinforcing: ASTM A1064 Cold-Drawn
  - E. Bolts: ASTM F1554, Grade 55  
Nuts: ASTM A563, Grade A Heavy Hex  
Washers: ASTM F436
  - F. Steel plates and Pole Cap: ASTM A36 or ASTM A709, Grade 50
  - G. Galvanization: Bolts, nuts and washers: ASTM F2329  
All other steel: ASTM A123
7. Pole Fabrication:
  - A. Cut the tip end of the prestressed strand first or simultaneously with the butt end.
  - B. For spiral reinforcing, one turn is required for spiral splices and two turns are required at the top and bottom of poles.
  - C. For Reinforcing Steel, lap splice to consist of a 3'-0" lap length at each splice. No more than two opposing rebar to be spliced at the same cross section. Stagger lap splices as needed.
  - D. Provide a Class 3 surface finish in accordance with Specification 400.
  - E. Provide a 1" minimum cover.
  - F. Provide handhole and coupler cover plates made of non-corrosive materials. Attach cover plates to poles using lead anchors or threaded inserts embedded in the poles in conjunction with round headed chrome plated screws.
  - G. Provide Identification Markings on the poles where indicated on the following sheets. Include the following information using inset numerals with 1" height or as approved in the Producers' Quality Control Program:  
  
Financial Project ID  
Pole Manufacturer  
Pole Length
  - H. Tie ground wires to the interior of reinforcing steel as necessary to prevent displacement during concreting operations.
  - I. Storage, Handling and Erection locations shown may vary within  $\pm 3"$ .
8. Cabinet Installation:
  - A. Splice fiber optic cables in cabinet to preterminater patch panel.
  - B. Furnish and install TVSS protection on all cabling in cabinet.
  - C. Furnish and install secondary TVSS protection on outlets for equipment in cabinet.
  - D. Ensure that all electronic equipment power is protected and conditioned with TVSS devices.
  - E. Ensure that equipment cabinet is bonded to CCTV pole grounding system.
  - F. Install the pole mounted cabinet with the hinges next to the pole.
  - G. Sizes and types of conduits and innerducts for network communications between the pullbox and cabinet are stated in the Contract Documents.
9. Lowering Device Installation:
  - A. Place the lowering cable that moves within the pole in an interior conduit to prevent it from tangling or interfering with any electrical wire that is in the pole. Ensure that any electrical wire within the pole is routed securely and free from slack.
  - B. Mount lowering arm perpendicular to the roadway or as shown in the plans. Position CCTV pole so that the camera can be safely lowered without requiring lane closures.
  - C. Coordinate all lowering device hardware requirements (including Tenon, Tenon mounting plates, parking stand, etc.) with lowering device manufacturer.

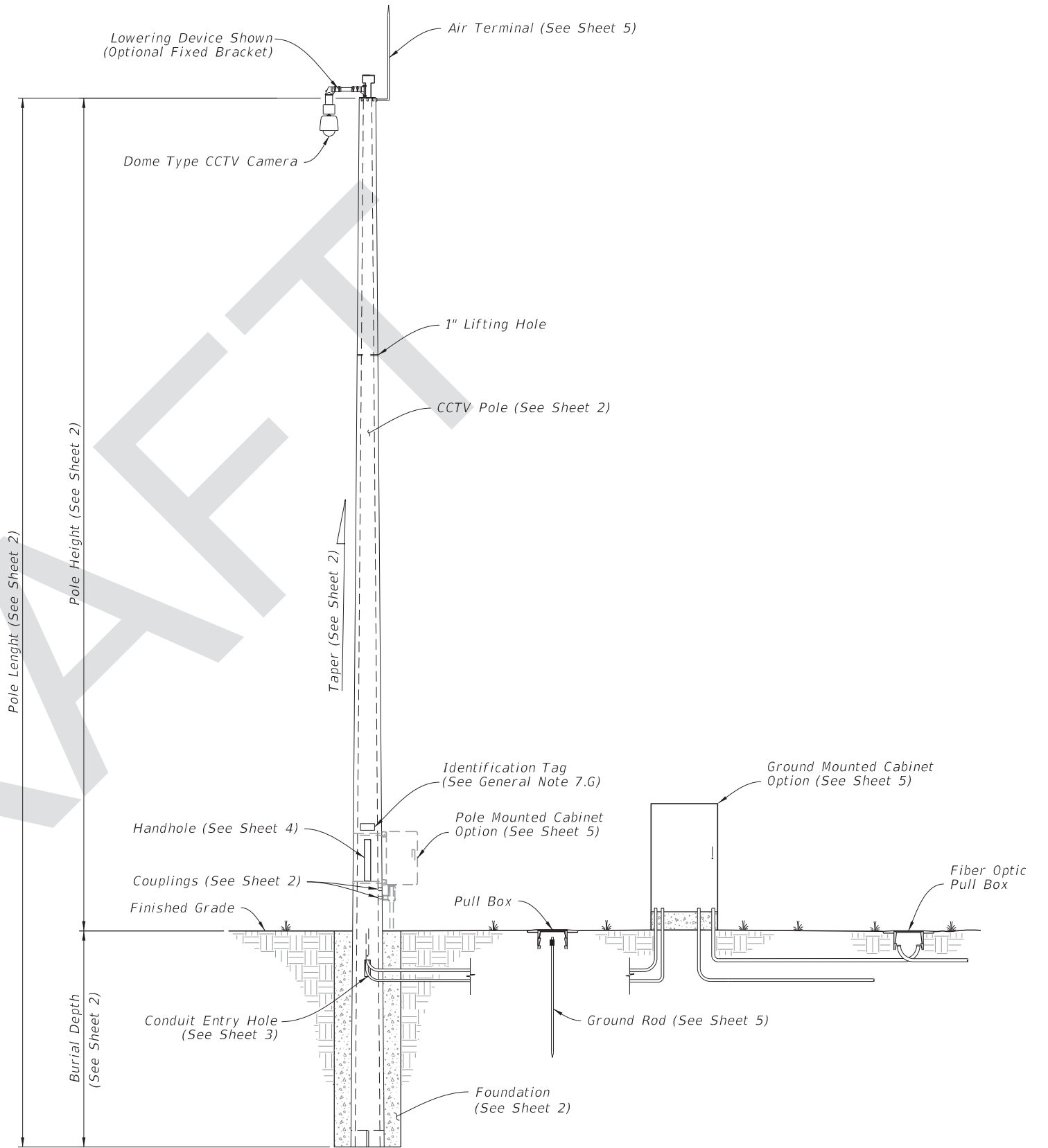

CCTV POLE ASSEMBLY

9/18/2017 10:04:24 AM

LAST REVISION 11/01/17	REVISION	DESCRIPTION:	 FY 2018-19 STANDARD PLANS	CONCRETE CCTV POLE	INDEX 641-020	SHEET 1 of 5
------------------------------	----------	--------------	---	--------------------	------------------	-----------------

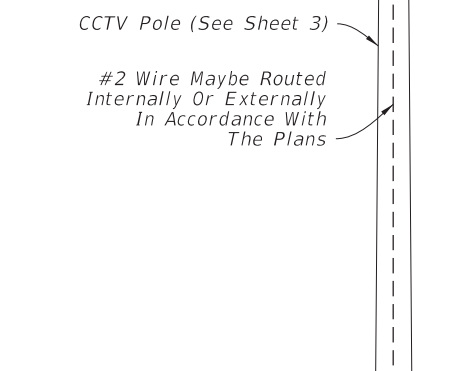
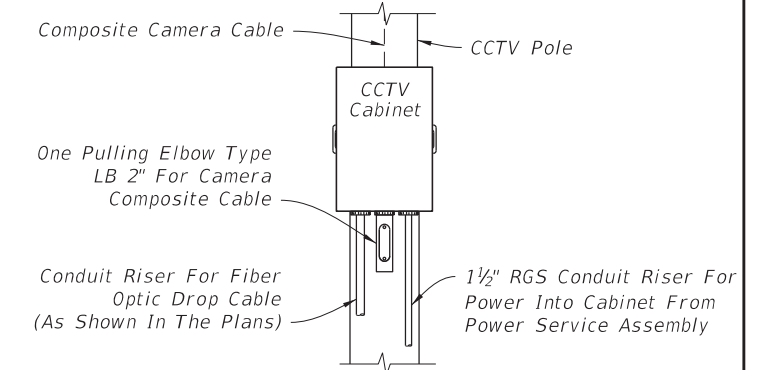
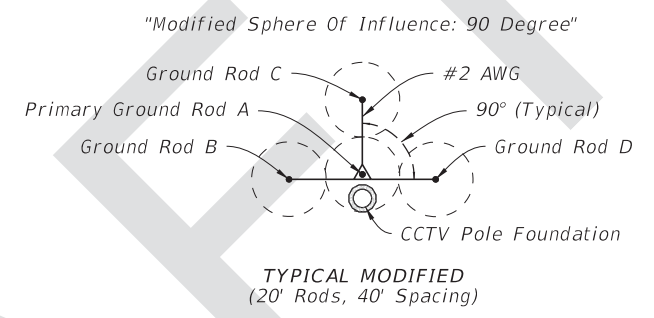
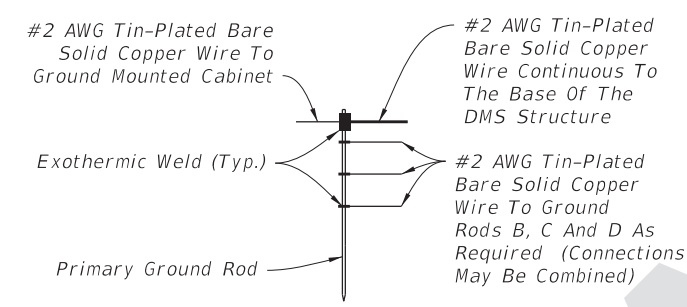
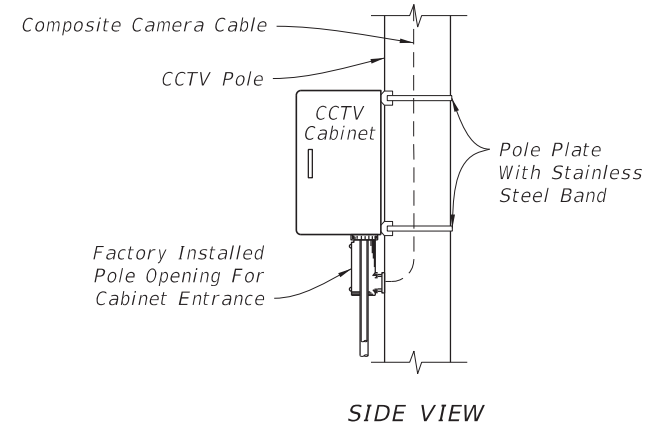
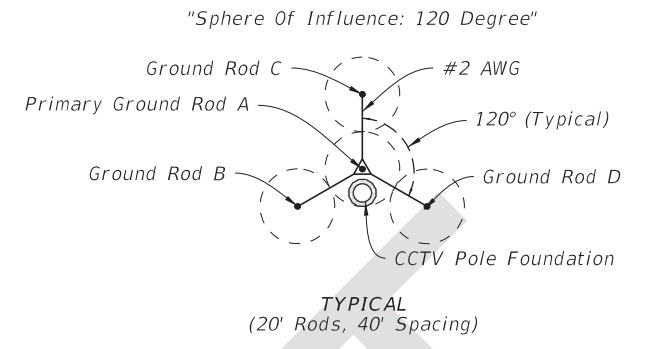
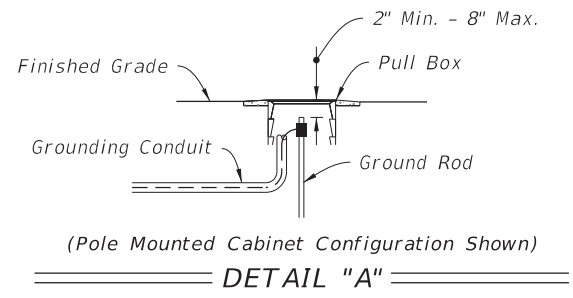
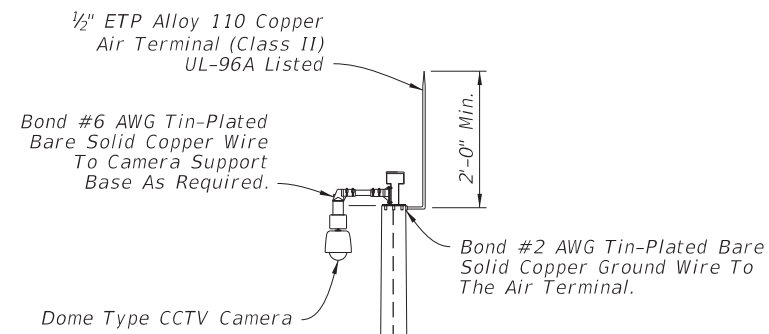

GROUND ROD ARRAY PLACEMENT

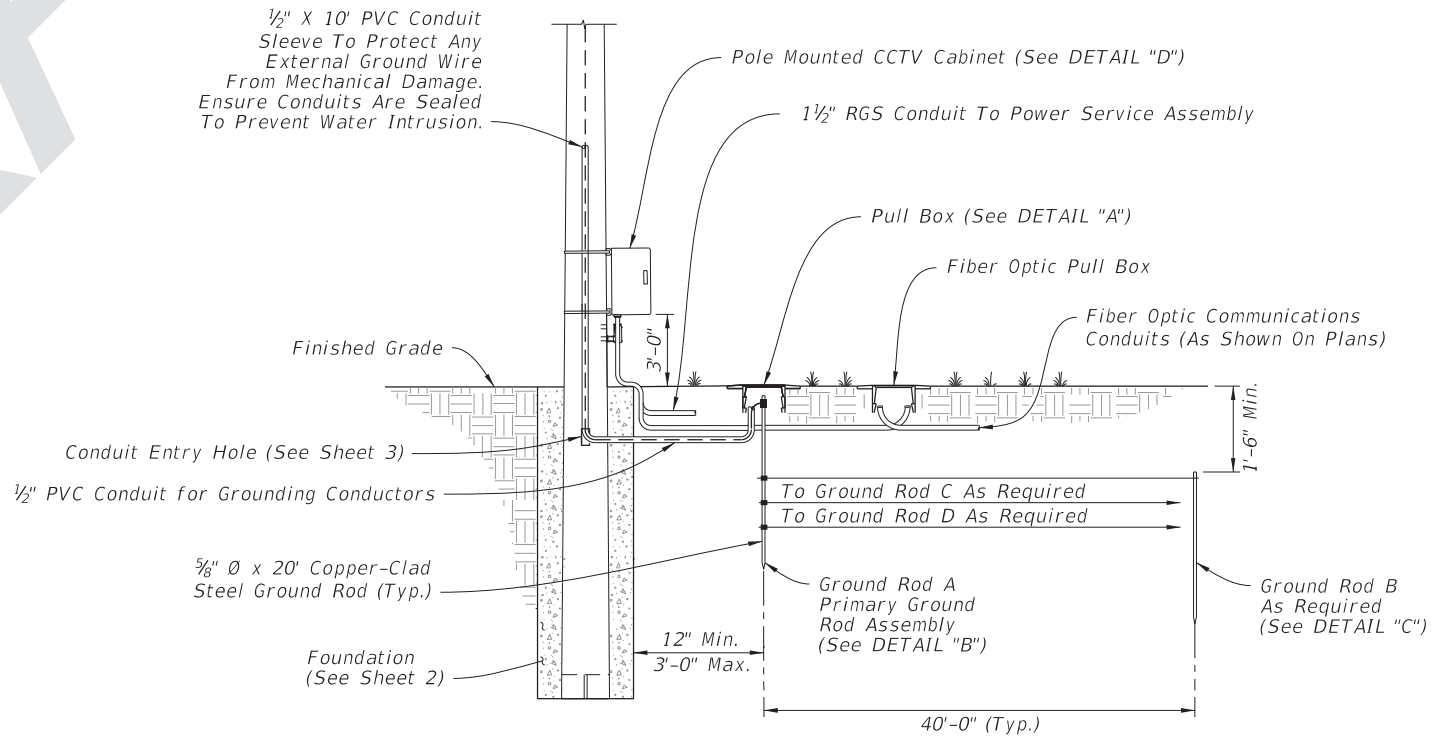
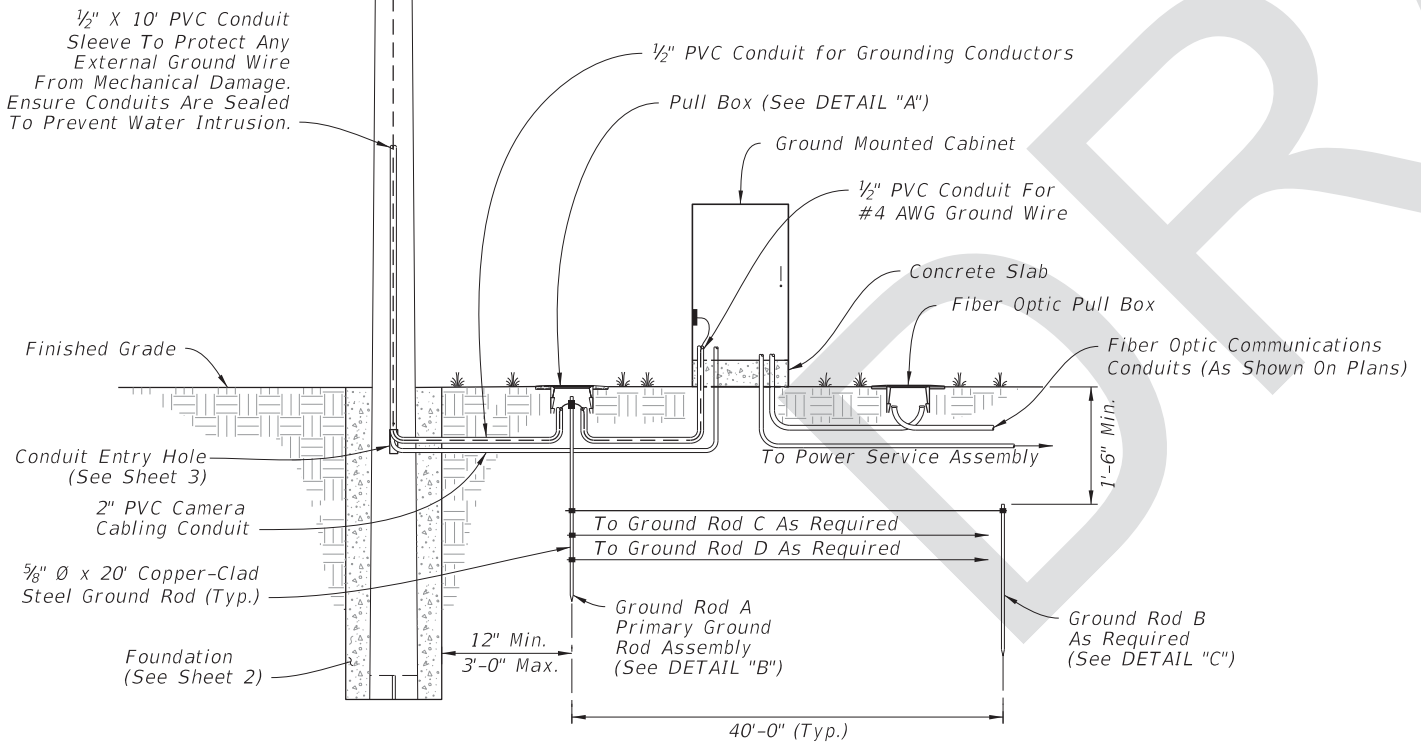

CONCRETE CCTV POLE GROUNDING

9/18/2017 10:04:27 AM

LAST REVISION	REVISION	DESCRIPTION:		FY 2018-19 STANDARD PLANS	CONCRETE CCTV POLE	INDEX 641-020	SHEET 5 of 5
11/01/17							