

Field Implementation of the Vertical In situ Permeameter (VIP)

Final Report

FDOT Contract No. BDV31-977-88

Submitted to:

Project Manager: David Horhota, Ph.D., P.E.
Florida Department of Transportation

Submitted By:

UF Principal Investigator: Michael Rodgers, Ph.D., P.E.
UF Co-Principal Investigator: Ana Mohseni, Ph.D.

May 31, 2021

University of Florida
Engineering School of Sustainable Infrastructure & Environment

Disclaimer

The opinions, findings, and conclusions expressed in this publication are those of the authors and not necessarily those of the State of Florida Department of Transportation.

SI (Modern Metric) Conversion Factors (from FHWA) Approximate Conversions to SI Units

SYMBOL	WHEN YOU KNOW	MULTIPLY BY	TO FIND	SYMBOL
LENGTH				
in	inches	25.4	millimeters	mm
ft	feet	0.305	meters	m
yd	yards	0.914	meters	m
mi	miles	1.61	kilometers	km
SYMBOL	WHEN YOU KNOW	MULTIPLY BY	TO FIND	SYMBOL
AREA				
in ²	square inches	645.2	square millimeters	mm ²
ft ²	square feet	0.093	square meters	m ²
yd ²	square yard	0.836	square meters	m ²
ac	acres	0.405	hectares	ha
mi ²	square miles	2.59	square kilometers	km ²
SYMBOL	WHEN YOU KNOW	MULTIPLY BY	TO FIND	SYMBOL
VOLUME				
fl oz	fluid ounces	29.57	milliliters	mL
gal	gallons	3.785	liters	L
ft ³	cubic feet	0.028	cubic meters	m ³
yd ³	cubic yards	0.765	cubic meters	m ³
NOTE: volumes greater than 1000 L shall be shown in m ³				
SYMBOL	WHEN YOU KNOW	MULTIPLY BY	TO FIND	SYMBOL
MASS				
oz	ounces	28.35	grams	g
lb	pounds	0.454	kilograms	kg
T	short tons (2000 lb)	0.907	megagrams (or "metric ton")	Mg (or "t")
SYMBOL	WHEN YOU KNOW	MULTIPLY BY	TO FIND	SYMBOL
TEMPERATURE (exact degrees)				
°F	Fahrenheit	5 (F-32)/9 or (F-32)/1.8	Celsius	°C
SYMBOL	WHEN YOU KNOW	MULTIPLY BY	TO FIND	SYMBOL
ILLUMINATION				
fc	foot-candles	10.76	lux	lx
fl	foot-Lamberts	3.426	candela/m ²	cd/m ²
SYMBOL	WHEN YOU KNOW	MULTIPLY BY	TO FIND	SYMBOL
FORCE and PRESSURE or STRESS				
lbf	pound force	4.45	newtons	N
lbf/in ²	pound force per square inch	6.89	kilopascals	kPa

Approximate Conversions to English Units

SYMBOL	WHEN YOU KNOW	MULTIPLY BY	TO FIND	SYMBOL
LENGTH				
mm	millimeters	0.039	inches	in
m	meters	3.28	feet	ft
m	meters	1.09	yards	yd
km	kilometers	0.621	miles	mi
SYMBOL	WHEN YOU KNOW	MULTIPLY BY	TO FIND	SYMBOL
AREA				
mm ²	square millimeters	0.0016	square inches	in ²
m ²	square meters	10.764	square feet	ft ²
m ²	square meters	1.195	square yards	yd ²
ha	hectares	2.47	acres	ac
km ²	square kilometers	0.386	square miles	mi ²
SYMBOL	WHEN YOU KNOW	MULTIPLY BY	TO FIND	SYMBOL
VOLUME				
mL	milliliters	0.034	fluid ounces	fl oz
L	liters	0.264	gallons	gal
m ³	cubic meters	35.314	cubic feet	ft ³
m ³	cubic meters	1.307	cubic yards	yd ³
SYMBOL	WHEN YOU KNOW	MULTIPLY BY	TO FIND	SYMBOL
MASS				
g	grams	0.035	ounces	oz
kg	kilograms	2.202	pounds	lb
Mg (or "t")	megagrams (or "metric ton")	1.103	short tons (2000 lb)	T
SYMBOL	WHEN YOU KNOW	MULTIPLY BY	TO FIND	SYMBOL
TEMPERATURE (exact degrees)				
°C	Celsius	1.8C+32	Fahrenheit	°F
SYMBOL	WHEN YOU KNOW	MULTIPLY BY	TO FIND	SYMBOL
ILLUMINATION				
lx	lux	0.0929	foot-candles	fc
cd/m ²	candela/m ²	0.2919	foot-Lamberts	fl
SYMBOL	WHEN YOU KNOW	MULTIPLY BY	TO FIND	SYMBOL
FORCE and PRESSURE or STRESS				
N	newtons	0.225	pound force	lbf
kPa	kilopascals	0.145	pound force per square inch	lbf/in ²

Technical Report Documentation Page

1. Report No.	2. Government Accession No.	3. Recipient's Catalog No.	
4. Title and Subtitle Field Implementation of the Vertical In situ Permeameter (VIP)		5. Report Date May 2021	
		6. Performing Organization University of Florida - ESSIE	
7. Author(s) Michael Rodgers, Ph.D., P.E.		8. Performing Organization Report No.	
9. Performing Organization Name and Address University of Florida –Engineering School of Sustainable Infrastructure and Environment 365 Weil Hall – P.O. Box 116580 Gainesville, FL 32511-6580		10. Work Unit No. (TRAIS)	
		11. Contract or Grant No. BDV31-977-88	
12. Sponsoring Agency Name and Address Florida Department of Transportation 605 Suwannee Street, MS 30 Tallahassee, FL 32399		13. Type of Report and Period Covered Final Report 01/2018 – 08/28/2021	
		14. Sponsoring Agency Code	
15. Supplementary Notes			
16. Abstract: This research involved improving the vertical in situ permeameter (VIP), a new apparatus developed in FDOT Project BDV31-977-23 for estimating in situ permeability, and validating the prior research results through statewide testing. The VIP is a unique wireless instrument that allows the engineer to estimate mean permeability at multiple depths relatively quickly compared to alternative test methods. The device's retractable tip helps to mitigate issues associated with soil smearing and siltation that can generate inaccurate readings. Throughout the course of the research, multiple tests were run with the instrument at different locations throughout the state of Florida. The collected permeability data were subsequently compared to results obtained at each site using standard in situ test methods, historical statewide trends, and the degree of permeability expected based on soil types encountered. The comparative analyses indicated the VIP compares favorably with standard methods and is capable of efficiently and accurately measuring permeability at multiple depths throughout the state of Florida.			
17. Key Words Hydraulic Conductivity, Permeability, Probe, In situ, Permeameter, Mean Permeability		18. Distribution Statement No restrictions.	
19. Security Classif. (of this report): Unclassified	20. Security Classif. (of this page): Unclassified	21. No. of Pages 125	22. Price

Acknowledgements

The UF research team would like to thank everyone who participated in the onsite training sessions and provided feedback. The assistance of the FDOT's State Materials Office field specialists Bruce Swidarski, Todd Britton, Kyle Sheppard, and Travis "Dalton" Stevens as well as the laboratory technicians is greatly appreciated, and without their assistance, this research would not have been possible.

Executive Summary

Measuring the permeability (hydraulic conductivity) of soil can be challenging due to the spatial heterogeneity of in situ conditions. Soil disturbance induced during testing can also lead to skewed permeability results. Over the years, several test methods have been developed to estimate permeability, including laboratory and field methods. Laboratory methods are often questionable due to inherent sample disturbance and many conventional field methods that induce less soil disturbance are expensive and time consuming, which makes the approach less ideal.

Recently, the Florida Department of Transportation developed a new permeability probe (BDV31-977-23), the vertical in situ permeameter (VIP), which performed well during a preliminary field testing investigation. The measurements obtained from the VIP were in good agreement with the results obtained from various conventional methods conducted at the same four sites. During the investigation, it was found that VIP field testing required far less time than the comparative conventional methods, which greatly improves efficiency and allows more data to be gathered with less effort. Based on the success of the preliminary field trials, a new Florida method of test was developed for the probe (FM 5-614). However, additional testing was recommended to validate the success of the preliminary trials and to introduce the new test method to each FDOT district.

The primary objective of this research was to implement VIP field testing throughout the state of Florida and further investigate the developed test method. This included testing the probe in each FDOT district and along the Turnpike. Secondary objectives included improving the test procedure and the probe's design, updating the test procedures and shop drawings provided in FM 5-614, fabricating eight probes and falling head vessels to distribute amongst the districts, and developing an instructional video for VIP training purposes and to promote the use of the newly developed test method.

During the research, the probe was redesigned to be more efficient, capable of percussive hammering, and to provide a wider range of reliable permeability measurements. The falling head vessel was also redesigned to be more robust and user friendly in the field. Once the new designs were complete, calibration standards were developed to ensure the probes and accompanying equipment functioned properly.

After the probe was redesigned and fabrication began, testing was implemented statewide to gain a better understanding of the probe's constraints and capabilities. From the research effort, it was found that the new probe and updated procedures now provide a reliable and accurate test method that can be used throughout the majority of the state. The applicability of the VIP probe is limited in some South Florida locations where rock is present near the ground surface because the probe is not designed to be pushed through or tested in rock. In locations where soil was present near the ground surface, the VIP permeability measurements compared well with conventional site investigation methods completed at each site, followed the expected permeability trends throughout the state based on historical data and the variable geological settings present within each district, and followed the expected trends of permeability based on the soil types tested. Furthermore, the new probe design now provides a measurable permeability

range between a high degree of permeability and relatively low permeability. Finally, it was concluded that the VIP is a suitable replacement to conventional permeability test methods and could provide continuity for permeability data collected throughout the majority of state.

Table of Contents

Disclaimer	ii
SI (Modern Metric) Conversion Factors (from FHWA) Approximate Conversions to SI Units ..	iii
Technical Report Documentation Page	v
Acknowledgements.....	vi
Executive Summary	vii
List of Figures	xii
List of Tables	xv
1. Introduction and Background	1
1.1 Introduction	1
1.2 Background	2
2. New VIP Probe Design.....	3
2.1 Field Specialist Recommendations	3
2.2 Prototype 1 Design.....	3
2.3 Friction Reducer Investigation.....	5
2.4 Prototype 1 Observations	9
2.5 Prototype 2 Design.....	10
2.6 Prototype Comparison.....	11
2.7 New Falling Head Vessel Design.....	12
2.8 VIP Probe and Falling Head Vessel Fabrication.....	14
2.8.1 Production Cost per VIP Probe and Falling Head Vessel.....	15
2.8.2 Fabrication Issues and Relevant Information in Regard to Fabrication	16
3. VIP Probe Calibration.....	17
3.1 Probe Mechanics	17
3.2 Developing VIP Calibration Standards.....	18
3.2.1 O-ring Compression Testing.....	18
3.2.2 Watertight Seal Testing.....	20
3.3 Upper Permeability Limit.....	22
3.4 Lower Permeability Limit	22
3.5 Shape Factor Investigation – Preliminary Testing	22
3.6 VIP Calibration Observations	25
4. Updating FM 5-614 and Creating a VIP Instructional Video.....	27
4.1 Scope	27
4.2 Apparatus	27

4.3	Probe Mechanics	28
4.4	Procedure.....	29
4.5	Calculations.....	32
4.6	Upper Permeability Limit.....	34
4.7	Equipment Checklist	35
4.7.1	VIP Probe Equipment Checklist.....	35
4.7.2	SPT Rig Equipment Checklist	36
4.8	VIP Test Setup	37
4.9	VIP Test Breakdown	38
4.10	Supplemental Information	39
4.11	VIP Data Sheet	40
4.12	Shop Drawings	41
4.12.1	VIP Probe.....	41
4.12.2	Falling Head Vessel	46
4.13	VIP Instructional Video.....	58
5.	VIP Field Testing and Analysis	59
5.1	District 1	59
5.1.1	Location C1.....	59
5.1.2	Location C2.....	60
5.1.3	Location C3.....	60
5.1.4	District 1 Summary	60
5.2	District 2.....	62
5.2.1	Trenton.....	63
5.2.2	Newberry.....	65
5.2.3	County Road 349	65
5.2.4	District 2 Summary	67
5.3	District 3.....	69
5.3.1	Marianna	69
5.3.2	Cottdale.....	71
5.3.3	District 3 Summary	72
5.4	District 4 & Turnpike	74
5.4.1	Location 1	74
5.4.2	Location 2	75
5.4.3	District 4 Summary	78

5.5	District 5	81
5.5.1	PBS 4	81
5.5.2	PBS 14	83
5.5.3	PBS 15	84
5.5.4	PBS 16	85
5.5.5	District 5 Summary	86
5.6	District 7 and Turnpike	88
5.6.1	Brooksville	89
5.6.2	District 7 and Turnpike – Veterans Expressway.....	91
5.6.3	District 7 and Turnpike Summary.....	92
5.7	Lower Permeability Limit	94
5.8	Florida Summary of Results.....	94
6.	Conclusions.....	103
7.	Recommendations.....	105
	References.....	107

List of Figures

Figure 2-1. Prototype 1 design based on recommendations from field specialists and research team.....	4
Figure 2-2. Push tests conducted in location 1 at the SMO.....	5
Figure 2-3. Push tests conducted in location 2 at the SMO.....	6
Figure 2-4. Push tests conducted at the Trenton, Florida location.....	6
Figure 2-5. Push tests conducted at the FDOT’s Kanapaha site in Gainesville, Florida.....	7
Figure 2-6. Soft limestone observed on the probe after extraction.....	7
Figure 2-7. Final push test analysis – the average axial resistance from three tested locations.	8
Figure 2-8. Comparing original VIP design with Prototype 1 and the two different friction reducers.....	9
Figure 2-9. VIP Prototype 2 depicting new threaded connections.....	10
Figure 2-10. VIP Prototype 1 and 2 comparison displaying nearly identical exterior dimensions.....	12
Figure 2-11. New falling head vessel design, displaying removable pieces.....	13
Figure 2-12. Eight new VIP probes.....	14
Figure 2-13. Seven new falling head vessels (prototype not depicted).....	15
Figure 3-1. VIP probe mechanics displaying (a) closed position and (b) open position.....	17
Figure 3-2. O-ring compression hand calibration procedure displaying a.) the probe remaining closed supporting its own weight and b.) the probe remaining open supporting its own weight.....	19
Figure 3-3. Watertight seal testing investigated locations.....	20
Figure 3-4. Watertight seal testing at approximately 45 feet of head.....	21
Figure 3-5. Sieve analyses from Location 1 in Trenton.....	23
Figure 3-6. Permeability results from VIP and CCH at three depths in Location 1 in Trenton. ..	23
Figure 3-7. Sieve analyses from Location 2 in Trenton.....	24
Figure 3-8. Push test results at Location 2 in Trenton.....	24
Figure 3-9. Permeability results from VIP and CCH at three depths in Location 2 in Trenton. ..	25
Figure 4-1. VIP probe mechanics.....	28
Figure 4-2. Step 1 of probe assembly.....	29
Figure 4-3. Step 2 of probe assembly.....	29
Figure 4-4. Step 3 of probe assembly.....	30
Figure 4-5. Step 4 of probe assembly.....	30
Figure 4-6. VIP test setup and measurements for mean permeability calculations.....	33
Figure 4-7. VIP assembly checklist.....	35
Figure 4-8. SPT rig equipment checklist.....	36
Figure 4-9. VIP test setup list.....	37
Figure 4-10. VIP test breakdown.....	38
Figure 4-11. VIP supplemental information.....	39
Figure 4-12. VIP data sheet.....	40
Figure 4-13. Probe layout.....	41
Figure 4-14. Nose cone.....	42
Figure 4-15. Inner rod.....	43
Figure 4-16. Friction reducer.....	44
Figure 4-17. AWJ connector.....	45
Figure 4-18. Falling head vessel overview.....	46

Figure 4-19. Top vessel plate.....	47
Figure 4-20. Bottom vessel plate.	48
Figure 4-21. Falling head vessel tank (piezometer).....	49
Figure 4-22. Threaded rods, bolts, and washers.	50
Figure 4-23. Stand plate.....	51
Figure 4-24. Leg connection overview.	52
Figure 4-25. Leg connection threaded plate and Connection-A screws.	53
Figure 4-26. Leg Connection-B nut and bolt.	54
Figure 4-27. Leg Connection-C screws and threaded spacer.	55
Figure 4-28. Stand legs and Connection-D plates.	56
Figure 4-29. Tank-hose connection pieces.	57
Figure 4-30. Image from VIP instructional video.....	58
Figure 5-1. Bartow Location C1 results by depth.....	59
Figure 5-2. Bartow Location C2 results by depth.....	60
Figure 5-3. Bartow Location C3 results by depth.....	60
Figure 5-4. District 1 summary of results by depth.	62
Figure 5-5. Trenton Location 1 sieve analyses.	63
Figure 5-6. Trenton Location 1 VIP and CCH results.	64
Figure 5-7. Trenton Location 2 sieve analyses.	64
Figure 5-8. Trenton Location 1 VIP and CCH results.	65
Figure 5-9. Newberry VIP results.....	65
Figure 5-10. SPT samples recovered at depths (a) 5 feet, (b) 10 feet, and (c) 15 feet.....	66
Figure 5-11. County Road 349 sieve analyses.....	66
Figure 5-12. County Road 349 VIP results.....	67
Figure 5-13. District 2 VIP results.....	69
Figure 5-14. SPT samples collected at a.) 10 feet and b.) 15 feet.	70
Figure 5-15. Marianna sieve analyses.....	70
Figure 5-16. Marianna VIP Results.	71
Figure 5-17. Soil samples collected at the Cottondale site.	71
Figure 5-18. Cottondale sieve analyses.	72
Figure 5-19. Cottondale VIP Results.....	72
Figure 5-20. District 3 VIP summary of results.....	73
Figure 5-21. District 4 Location 1 sieve analyses.....	75
Figure 5-22. District 4 Location 1 VIP results.....	75
Figure 5-23. VIP probe with electric tape to ensure closed position for open-hole advancement.	76
Figure 5-24. District 4 Location 2 sieve analyses.....	77
Figure 5-25. District 4 Location 2 VIP results.....	77
Figure 5-26. Grease transmitted through the drill string and out of the probe.	78
Figure 5-27. District 4 summary of VIP results.....	80
Figure 5-28. District 4 hydraulic conductivity plotted as a function of SPT blow counts.	81
Figure 5-29. VIP being used for an infiltrometer tests.	82
Figure 5-30. Location PBS 4 sieve analyses.....	83
Figure 5-31. Location PBS 4 VIP and CCH results.....	83
Figure 5-32. Location PBS 14 sieve analyses.....	84
Figure 5-33. Location PBS 14 VIP and CCH results.....	84

Figure 5-34. Location PBS 15 sieve analyses.....	85
Figure 5-35. Location PBS 15 VIP and CCH results.....	85
Figure 5-36. Location PBS 16 sieve analyses.....	86
Figure 5-37. Location PBS 16 VIP and CCH results.....	86
Figure 5-38. District 5 summary of VIP results.....	88
Figure 5-39. Brooksville Location P-1 and P-2 sieve analyses.	89
Figure 5-40. Brooksville Location P-1 and P-2 VIP results.	90
Figure 5-41. Brooksville Location P-3 sieve analyses.....	90
Figure 5-42. Brooksville Location P-3 VIP results.	91
Figure 5-43. Fine grained soil recovered by a hand auger at the Veterans Expressway site.....	91
Figure 5-44. D7 Turnpike - Veterans Expressway VIP results.	92
Figure 5-45. District 7 VIP results.....	93
Figure 5-46. VIP cumulative frequency distributions for each FDOT district and Florida.....	95
Figure 5-47. VIP cumulative frequency distributions for FDOT District 3 and Florida.	95
Figure 5-48. VIP cumulative frequency distributions for FDOT District 2 and Florida.	96
Figure 5-49. VIP cumulative frequency distributions for FDOT District 5 and Florida.	96
Figure 5-50. VIP cumulative frequency distributions for FDOT District 7 and Florida.	97
Figure 5-51. VIP cumulative frequency distributions for FDOT District 1 and Florida.	98
Figure 5-52. VIP cumulative frequency distributions for FDOT District 4 and Florida.	98
Figure 5-53. VIP cumulative frequency distributions for Florida based on AASHTO soil type.	100
Figure 5-54. Saturation hydraulic conductivity vs. VIP test hydraulic conductivity.....	102

List of Tables

Table 2-1. VIP probe estimated fabrication costs.....	15
Table 2-2. Falling head vessel estimated fabrication cost.	16
Table 5-1. District 1 summary of VIP test results.	61
Table 5-2. District 1 VIP test summary of statistics.	62
Table 5-3. District 2 summary of VIP results.	68
Table 5-4. District 2 summary of statistics.	69
Table 5-5. District 3 summary of VIP results.	73
Table 5-6. District 3 VIP summary of statistics.....	74
Table 5-7. District 4 summary of VIP results.	79
Table 5-8. District 4 VIP summary of statistics.....	80
Table 5-9. Summary of VIP Test Results.	87
Table 5-10. District 5 VIP summary of statistics.....	88
Table 5-11. District 7 summary of VIP results.	93
Table 5-12. District 7 VIP summary of statistics.....	94
Table 5-13. VIP summary of statistics for each FDOT district and all of Florida combined.....	94
Table 5-14. Soil classification based on coefficient of permeability (Terzaghi and Peck 1967). 99	
Table 5-15. VIP permeability summary of statistics for soil types encountered during the project.	99

1. Introduction and Background

1.1 Introduction

Measuring the permeability (hydraulic conductivity) of soil can be challenging due to the spatial heterogeneity of in situ conditions. Grain size, grain orientation, density, degree of saturation, and soil type all affect permeability. Consequently, soil disturbance induced during testing can lead to skewed permeability results. Over the years, several test methods have been developed to estimate permeability, including laboratory and field methods. Laboratory methods are often questionable due to the inherent sample disturbance that occurs during extraction and transport, whereas field methods induce less disturbance and provide better insight into the in situ nature of the soil. Therefore, field testing is often preferred to laboratory testing. However, many conventional field methods (e.g., cased and uncased borehole methods) are expensive and/or time consuming and still induce soil disturbance which make the approach less ideal.

Several drive-point probes have been developed in the recent past in an attempt to improve the efficiency and accuracy of collecting permeability data in situ. The advantages of these probe types are simplified testing procedures, faster setup and testing times, less soil disturbance, and more-detailed information about vertical variations in permeability when compared with conventional in situ permeability tests. The devices are designed to be directly pushed into the soil or advanced using percussion (SPT) hammers (Butler et al. 2007). Generally, the drive-point devices are small-diameter probes with tapered conical tips similar in concept to a standard cone penetrometer (CPT) which reduces resistance and associated soil disturbance when taking measurements. The general test procedures include pushing the drive-point probe to the desired test depth, releasing water from the probe in the lateral direction through injection screens, and measuring the flowrate. Permeability is derived from the measured flowrate using shape factors developed based on the probe's geometry.

In general, drive-point probes cause less disturbance than conventional borehole methods; however, skin effects may still skew results. To clarify, disturbances may be created alongside the probe as a result of channeling, compaction, smearing, or siltation. Channeling is often a result of injecting water during probe advancement, which can be resolved by eliminating flow during advancement; and compaction issues typically develop from percussive advancement, which is resolved by using direct-push techniques closer to the test depth. However, smearing and siltation are a result of the soil type encountered, and reducing these effects is largely dependent upon the design of the drive point device.

Smearing occurs when a fat clay layer is encountered during advancement and the highly-plastic, cohesive soil cakes the injection screens. Because siltation occurs in cohesive soil layers with lower plasticity, the fine-grained soil, in a liquid state, enters the probe through the injection screens. In both cases, the injection screens are either partially or fully clogged, which leads to inaccurate measures of hydraulic conductivity. This is because measurements derived from drive-point devices are dependent upon the geometry of the injection screens with the assumption that a full flow condition is achieved. Consequently, partially, or fully clogged injection screens can produce discrepancies in permeability measurements, which need to be resolved to ensure accurate and reliable permeability data are collected for design.

1.2 *Background*

Recently, the University of Florida and the Florida Department of Transportation developed a new permeability probe, the Vertical In situ Permeameter (VIP), which performed well during a preliminary field testing investigation (BDV31-977-23). The new probe was designed with a retractable tip which provides vertical fluid injection. The probe's name, Vertical In situ Permeameter (VIP), is a reflection of the vertical injection of water as the probe itself measures mean permeability, not vertical permeability. The circular injection surface/retractable tip design is different from previous direct-push probes because it does not utilize a well screen with horizontal injection. Thus, smearing and/or siltation effects are minimized by the unique design. Furthermore, the VIP's vertical injection eliminates misleading results caused by the well screen positioned between two different soil layers.

The measurements obtained from the VIP in the preliminary investigation were in good agreement with the results obtained from various conventional methods conducted at the same sites. During the investigation, it was found that VIP field testing required far less time than the comparative conventional methods which greatly improved the efficiency and allowed more data to be gathered with less effort. In total, 104 VIP tests were run at 72 depths ranging from 4 feet to 15 feet across the 4 sites, both above and below the water table, in soil types with permeability measurements ranging from approximately 1×10^{-5} cm/s to 1×10^{-2} cm/s. Based on the success of the preliminary field trials, a new Florida method of test was developed for the probe (FM 5-614). However, additional testing was recommended to validate the success of the preliminary trials and to introduce the new test method to each FDOT district.

The primary objective of this research was to implement VIP field testing throughout the state of Florida and further validate the developed test method. This included testing the probe in 6 of 7 FDOT districts and along the Turnpike (Note: VIP testing in District 6 was unable to be completed due to COVID-19 restrictions). From testing throughout the majority of the state, variable soil and field conditions (soil stratigraphy) were encountered that provided a better understanding of the probe's capabilities. Secondary objectives included improving the test procedure and the probe's design, updating the test procedures and shop drawings provided in FM 5-614, fabricating 8 probes and falling head vessels to distribute amongst the districts, and developing an instructional video for VIP training purposes and to promote the use of the newly developed test method.

2. New VIP Probe Design

During the research, the probe design provided in the original FM 5-614 was investigated. The FDOT's state materials office field operations specialists were also consulted to get an opinion on the current design and what could be done to improve the VIP probe. This chapter details the findings from the investigation and the updated probe design.

2.1 *Field Specialist Recommendations*

During the prior VIP research conducted by the FDOT, permeability data measured by the VIP probe were found to be in good agreement with conventional testing in four locations. During these preliminary trials, the FDOT's Field Operation Specialists from the State Materials Office (SMO) conducted each test, giving the field specialists firsthand knowledge of the probe's shortcomings in terms of test operations. Therefore, the SMO field specialists were consulted to gain insight on how the probe could be improved to make testing more efficient and effective. The following list provides the suggestions made by the field specialists:

- A more robust design that would allow percussive advancement to take place (i.e., the ability to use the SPT hammer),
- Alter the thread type as too much time is required to assemble the probe due to the long threaded sections,
- Eliminate the use of set screws (time consuming and easy to lose the small screws),
- Increase the exterior length of the connector piece so a wrench can be used to disassemble the probe,
- Increase the stroke length of vertical lift to open the probe for testing to an easier to measure length (Originally 1.625 inches which can be difficult to precisely measure in the field), and
- Reduce the diameter of the friction reducer to generate less resistance during advancement.

2.2 *Prototype 1 Design*

Based on the field specialists' recommendations, and observations made by the UF research team, a new prototype was designed and presented in Figure 2-1.

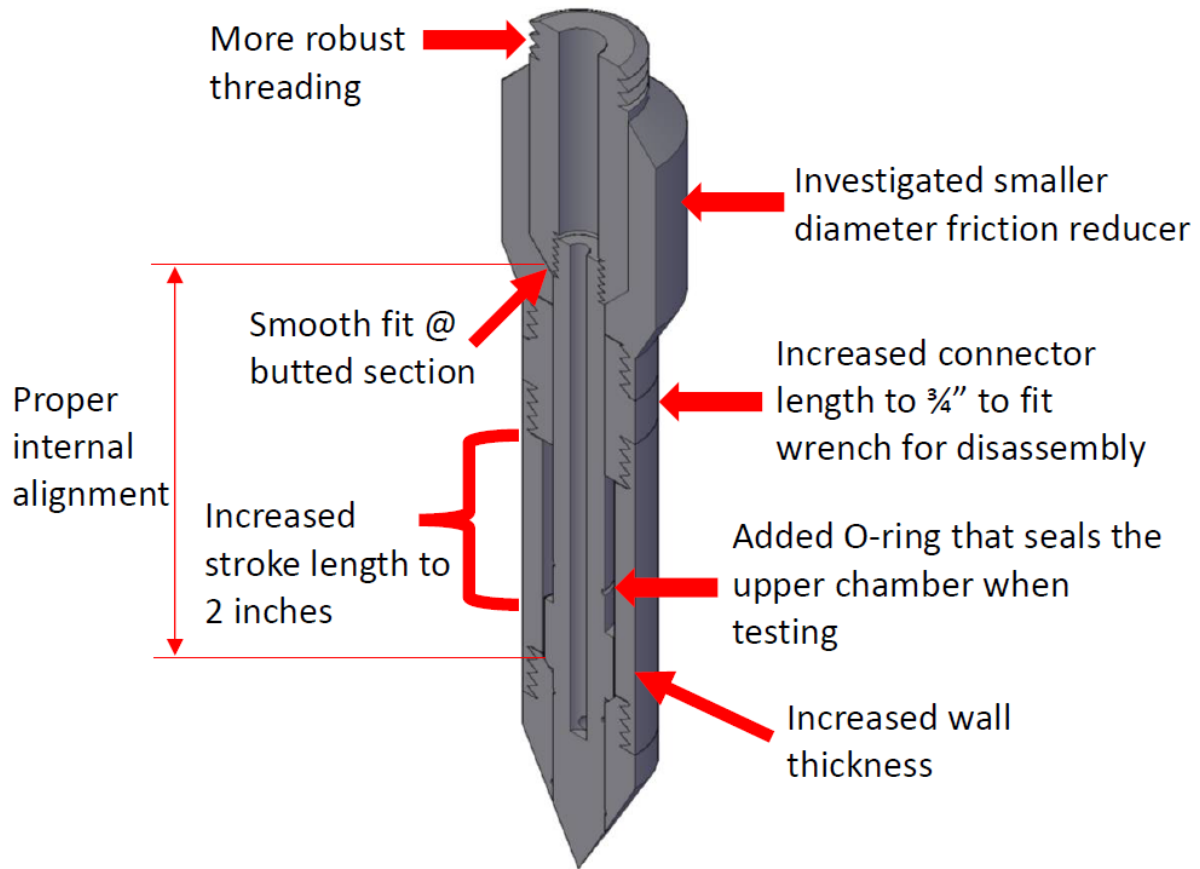

Figure 2-1. Prototype 1 design based on recommendations from field specialists and research team.

The Prototype 1 design was similar to the original VIP design as it still incorporated seven individual pieces (AWJ connection not depicted) with five threaded connections. However, Prototype 1 was designed to be more robust and user friendly with following key additions:

- More robust threading and increased wall thickness to allow percussive advancement,
- The added thread type also requires less turns and time to assemble/disassemble the probe,
- The stroke length was increased to two inches, so it is easier to track the vertical lift required to open the probe tip for field testing,
- The connector length was extended to $\frac{3}{4}$ inches to allow a wrench to be used during disassembly,
- Smooth fitting sections that butt up against each other during advancement to distribute the axial load over a larger surface area,
- Proper internal alignment where the larger section of the inner rod butts up against the probe head simultaneously with the AWJ connection/friction reducer butted section. Again, this was done to distribute the axial force generated during advancement to a larger surface area both at the upper and lower sections of the probe. Consequently, stress

concentrations are reduced throughout the probe which allows larger axial and percussive forces to be used during advancement,

- An O-ring was added to the inner rod above the larger diameter section which seals the upper chamber of the probe during testing. This ensures that water only exits through the intended flow port at the tip of the probe. This will ultimately provide more reliable and accurate measurements of hydraulic conductivity and improve the lower permeability limit,
- Removed the use of set screws,
- Designed with two different diameter friction reducers.

2.3 Friction Reducer Investigation

Two different diameter friction reducers (2" and 2.25") were investigated to determine if a smaller diameter would significantly reduce axial resistance during advancement, while maintaining the desired functionality of lifting the AWJ rods with minimal resistance to open the probe for testing. To investigate the resistance generated by each diameter, the instrumented drill rod used in BDV31-820-006 was placed in-line with the AWJ rods and push tests were conducted to measure axial force during advancement with both diameters at the same approximate location. In total, four push tests were conducted at three different sites: two locations at the SMO, one location at the FDOT's Kanapaha site in Gainesville, and one location in Trenton. Figures 2-2 through 2-5 provide the comparative results of each push test.

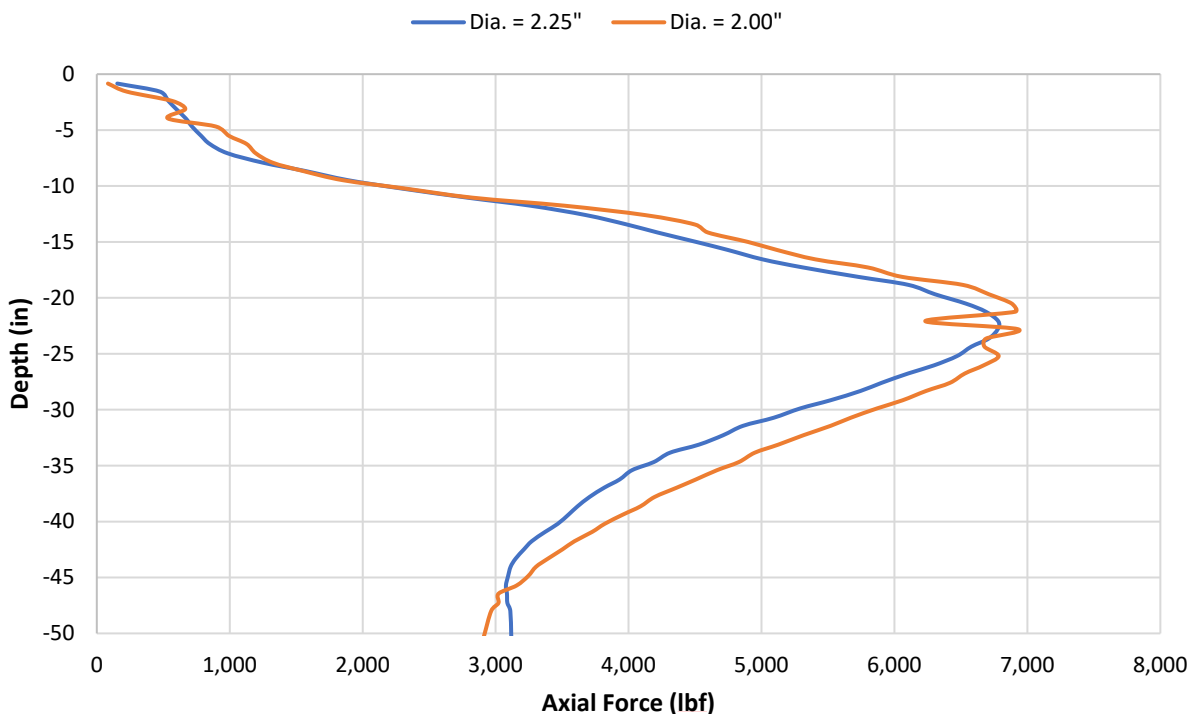

Figure 2-2. Push tests conducted in location 1 at the SMO.

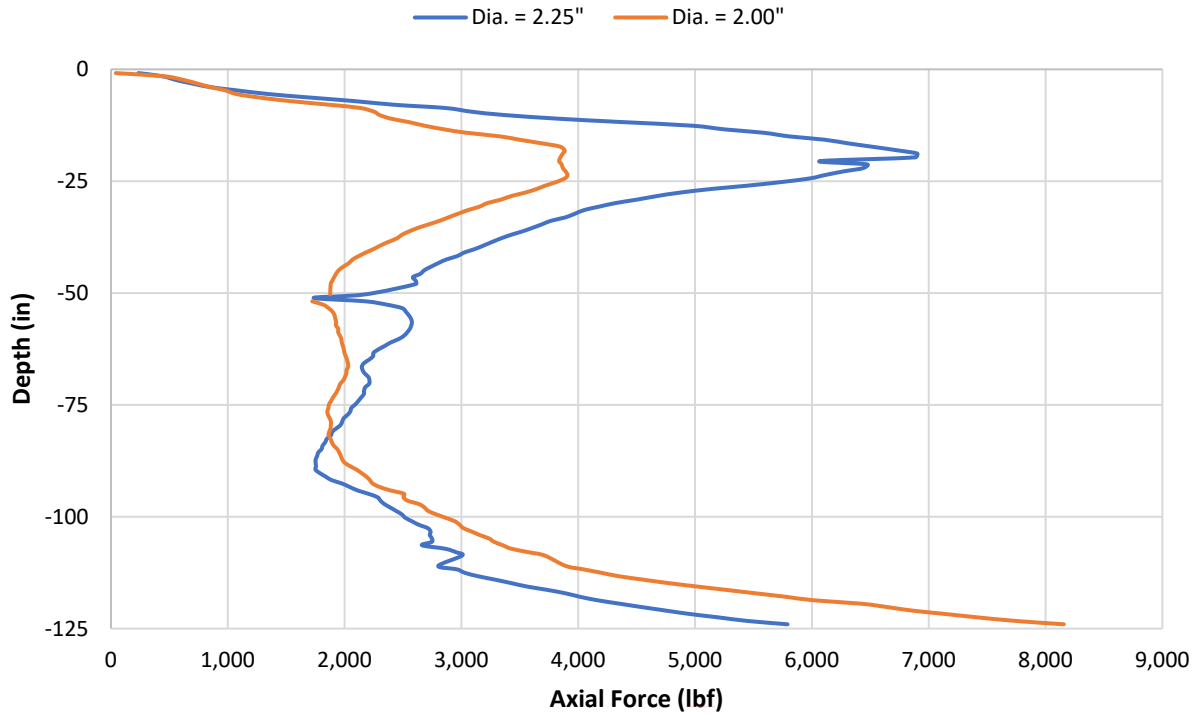

Figure 2-3. Push tests conducted in location 2 at the SMO.

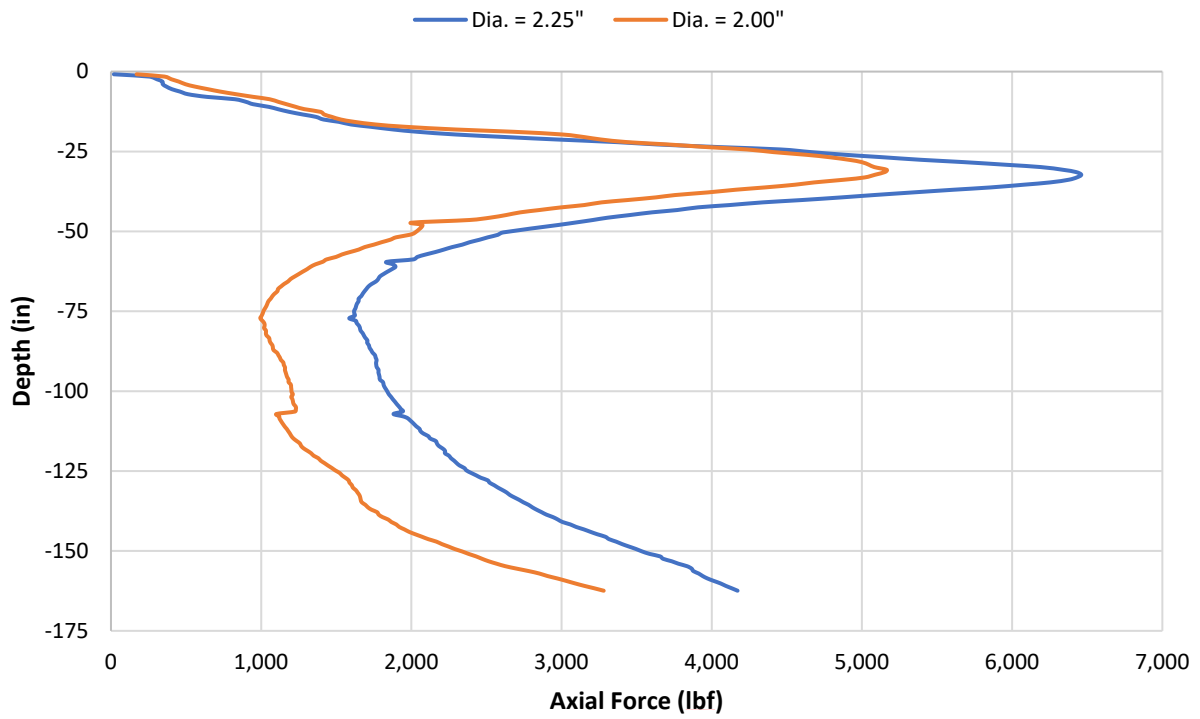

Figure 2-4. Push tests conducted at the Trenton, Florida location.

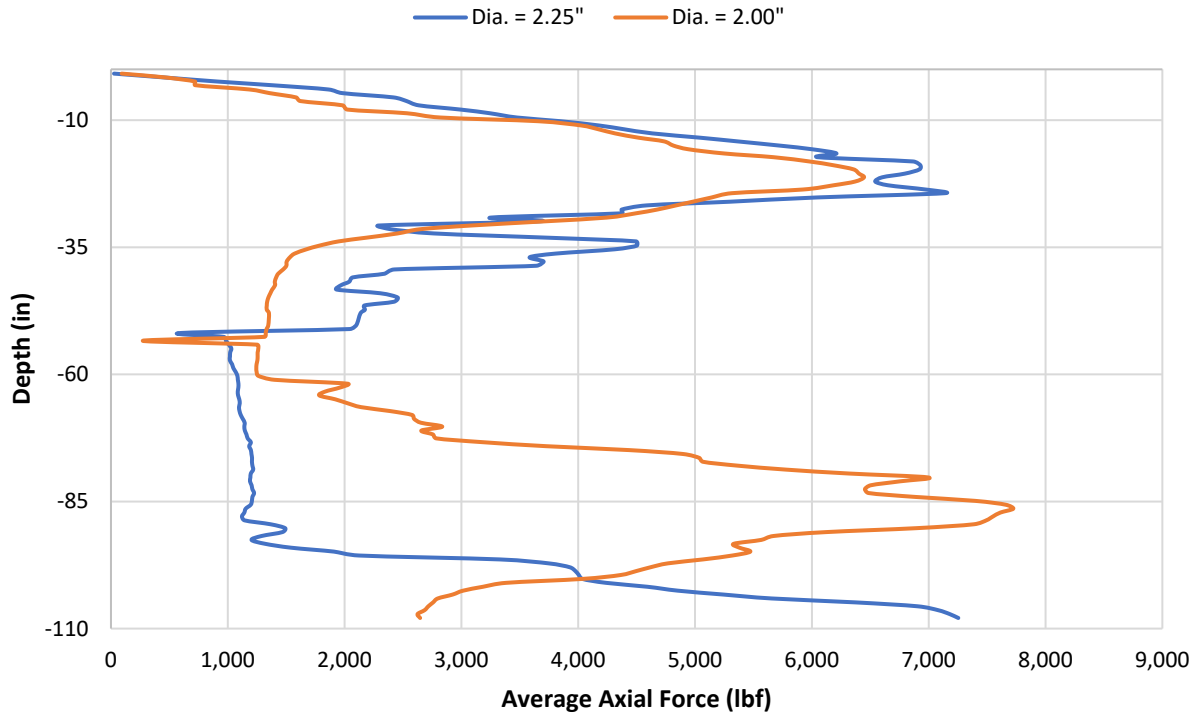

Figure 2-5. Push tests conducted at the FDOT’s Kanapaha site in Gainesville, Florida.

In Figures 2-2 through 2-4, the same general soil profile can be observed. In Figure 2-5, at Kanapaha, the two soil profiles show less similarities. This is due to the highly variable nature of the Kanapaha site and encountering soft limestone at two different depths. Encountering the soft limestone was confirmed by observing rock collected on the probe after it was extracted, Figure 2-6.

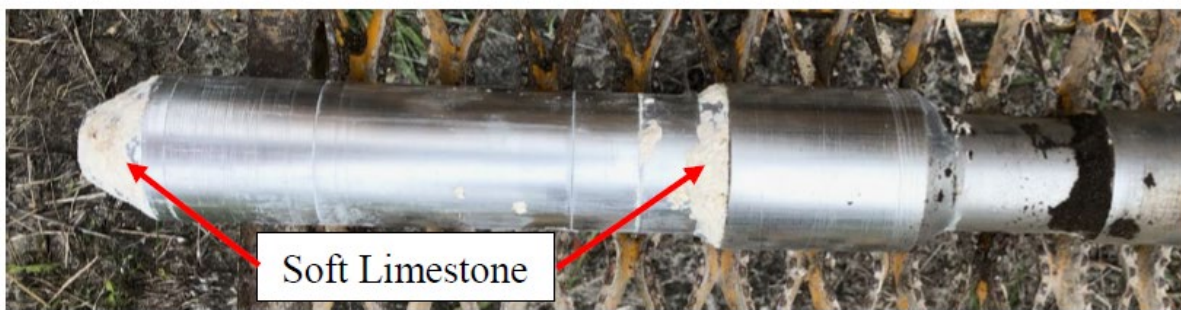

Figure 2-6. Soft limestone observed on the probe after extraction.

Due to the encounter with limestone at two different depths, the push tests at Kanapaha were not considered for the final push test analysis. However, the ability for the new robust VIP design to be pushed through limestone twice was an encouraging result in regard to the durability of the new probe.

For the push test final analysis, the results from the three tests conducted in soil were combined to provide the average resistance at each measured depth increment. This was done in attempt to eliminate any bias generated from the variability of the soil. To clarify, it is entirely possible, and quite likely, for the density of soil to vary from each tested location on site, even when the distance separating the two tests was two to three feet in distance. The analysis only considered the measurements recorded to a depth of approximately 125 inches to ensure data from at least two different locations were included to generate the average (Note: only at the Trenton site did the push test advance further than 125 inches). The final push test analysis is presented in Figure 2-7 which provides the average axial resistance measured per recorded depth increment.

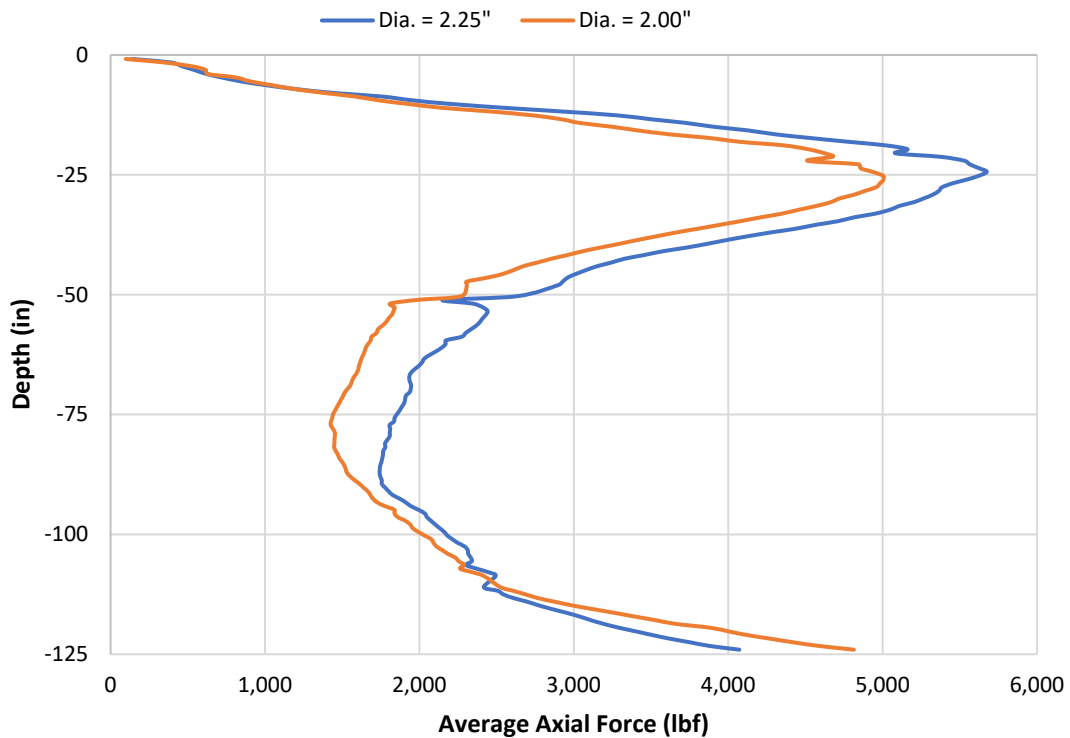

Figure 2-7. Final push test analysis – the average axial resistance from three tested locations.

As observed in Figure 2-7, the average decrease in axial resistance from using a smaller diameter friction reducer was minimal. In all tested locations, the axial resistance with the smaller diameter actually increased at various depths. In addition, the axial resistance lifting the AWJ rods to open the probe increased at all tested locations and depths when using the smaller diameter friction reducer. Consequently, the larger diameter (original VIP diameter) was selected for the final design. The fabricated prototype is presented in Figure 2-8 to compare with the original VIP design and to illustrate the two different diameter friction reducers that were investigated.

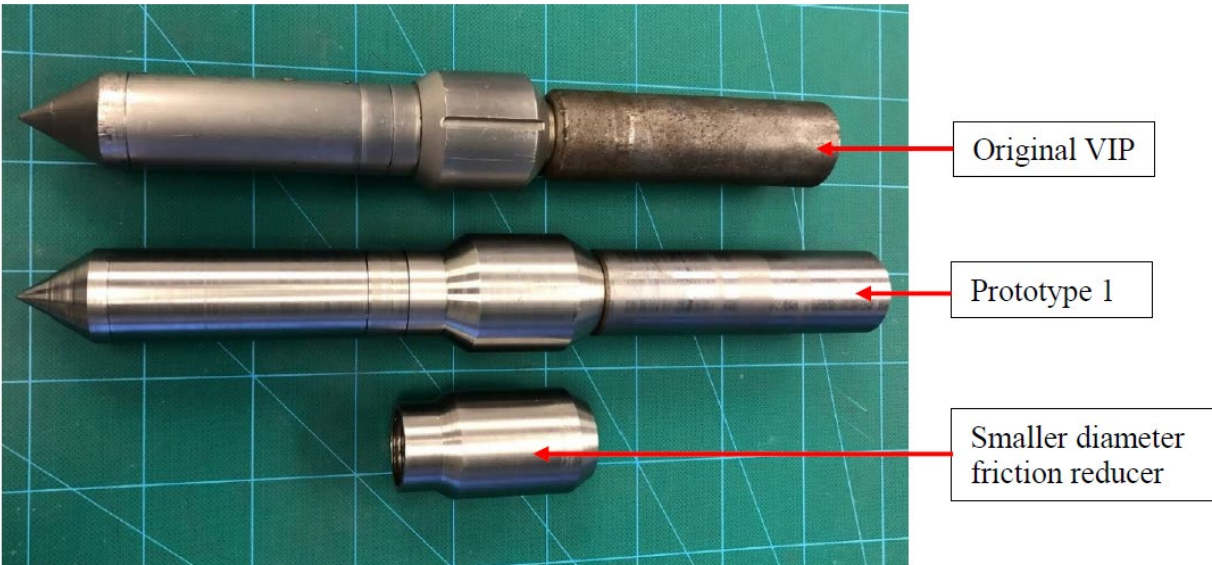

Figure 2-8. Comparing original VIP design with Prototype 1 and the two different friction reducers.

2.4 *Prototype 1 Observations*

Comparing Prototype 1 with the original VIP design, the following improvements were identified:

- The robust design allowed percussive advancement to take place which was tested after the probe could no longer be directly pushed at the SMO,
- There was a reduction in assembly time compared to original probe due to less time threading and the elimination of set screws,
- The longer connector provided easier assembly and disassembly,
- Increasing the stroke length to two inches made it easier to ensure the probe achieved the open position for testing,
- The new design provided a higher upper permeability limit.

However, in the opinion of the UF research team and the SMO field specialists, Prototype 1 was still not satisfactory as a final working design to be fabricated and distributed amongst the FDOT districts. The following problems were identified:

- The assembly/disassembly was still time consuming due to the probes seven individual pieces and five threaded connections.
- As part of the scope of work, the research team was tasked with working closely with the machine shops to identify and report any issues in the fabrication process. Two issues were identified with the Prototype 1 design. The first being the difficulties fabricating a concentric connector piece with the larger robust threading. The result of this issue is the effect on the probe's mechanics when opening and closing the probe. Due to eccentricity of the connector, if the inner rod were rotated in a specific location, the inner rod would cease up due to the misalignment and the probe could not be easily opened or closed

which requires the probe to be extracted, disassembled, cleaned, realigned, and advanced to the now disturbed test depth (i.e., significant waste of time and effort). Seizing of the inner rod may also provide false readings if the probe is assumed to be fully open at the tip when it is not due to the malfunction. The second fabrication issue was developing the proper internal alignment, so the desired pieces butt up against each other simultaneously. This was a result of having seven individual pieces and five threaded connections to account for. Ultimately, this leads to stress concentrations within the probe that effect the structural integrity. In total, both issues caused nearly nine months of fabrication delays, which is unacceptable when the desired outcome is to provide a functional probe that is easy to fabricate and implement testing.

- In addition to the fabrication issues, external unthreading was noticed at the probe head when the probe was extracted after testing. The research team believes the issue is a result of the small clockwise rotation that takes place when adding AWJ rods to push to deeper test depths. As the rotation takes place at the top of the hole, the same rotation is generated through the inner rod in which the O-rings pressing against the probe head unthread the connection. Improper internal alignment due to the eccentric connector increases the likelihood of unthreading as one side of the inner rod presses harder against the probe head. Set screws would alleviate some of the issue but increase the time of assembly/disassembly.

2.5 Prototype 2 Design

Due to the issues described in the prior section, a new prototype was developed. Prototype 2 provides a simplified design, Figure 2-9, which includes only 4 individual pieces and two threaded connections. The following individual pieces from Prototype 1 were combined:

- Probe head and main chamber → Probe head
- Connector and friction reducer → Friction reducer
- AWJ adaptor connection and AWJ adaptor → AWJ adaptor

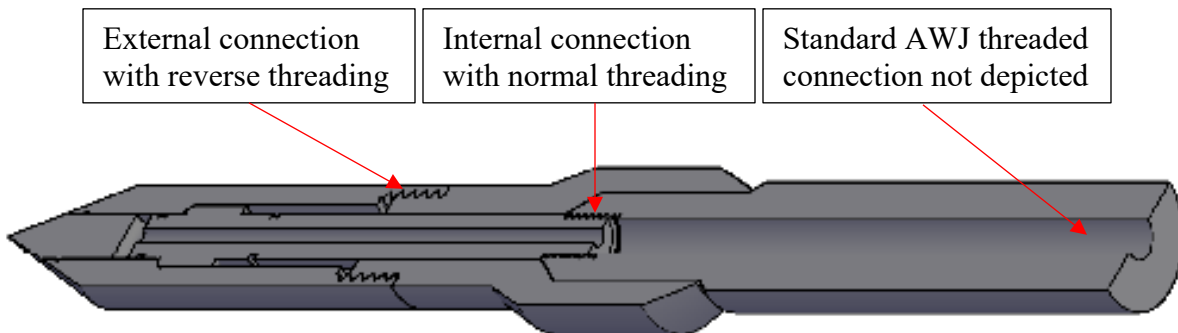

Figure 2-9. VIP Prototype 2 depicting new threaded connections.

Due to the simplified design, only one internal threaded connection (inner rod to AWJ adaptor) and one external threaded connection (friction reducer to probe head) is required. The external threaded connection utilizes reverse threading to ensure the probe head is not unthreaded when

adding AWJ rods. Prototype 2 also utilizes the beneficial Prototype 1 attributes that improved the design which includes:

- Robust threading and increased wall thickness which allows percussive advancement,
- Two inch stroke to more easily track the vertical lift required to open the probe for testing,
- Upper chamber O-ring to ensure water only exits the probe head flow port during testing,
- Proper internal alignment to distribute the axial force generated during advancement over a larger surface area.

It should be noted that in the past, the AWJ adaptors were developed as an individual piece to allow different rod types to be incorporated into the VIP system. However, in most cases AWJ rods are the rod type used with SPT rigs based on the survey results collected in BDV31-820-006. The other common rod types identified in the survey results were NW and NWJ rods, both of which have an outer diameter of 2-5/8 inches which is larger than the friction reducer outer diameter. Consequently, VIP tests could not be performed with these rod types and thus it was decided to incorporate the AWJ connector into the design as a standard connection. In addition, sub-adaptors are commercially available that would allow various uncommonly used rod types to be used with the VIP system.

2.6 *Prototype Comparison*

A steel VIP Prototype 2 probe was fabricated and tested in Trenton in which the probe's performance was excellent. Based on field observations the following advantages were identified with Prototype 2:

- Same robust design with only four pieces and two threaded connections compared to seven pieces with five threaded connections.
- Assembly is less time consuming and generally takes less than 30 seconds.
- Easier to fabricate concentric probe pieces.
- Easier to fabricate proper internal alignment.
- Based on quotes acquired there is a twenty percent reduction in fabrication cost compared to Prototype 1.
- External unthreading was eliminated by reversed external threaded connection. Therefore, set screws are no longer necessary.

For convenience, Figure 2-10 provides a side by side external comparison between the two fabricated prototypes. Based on the observations discussed and the preliminary field test results, Prototype 2 was selected for the final VIP design to be added to FM 5-614.

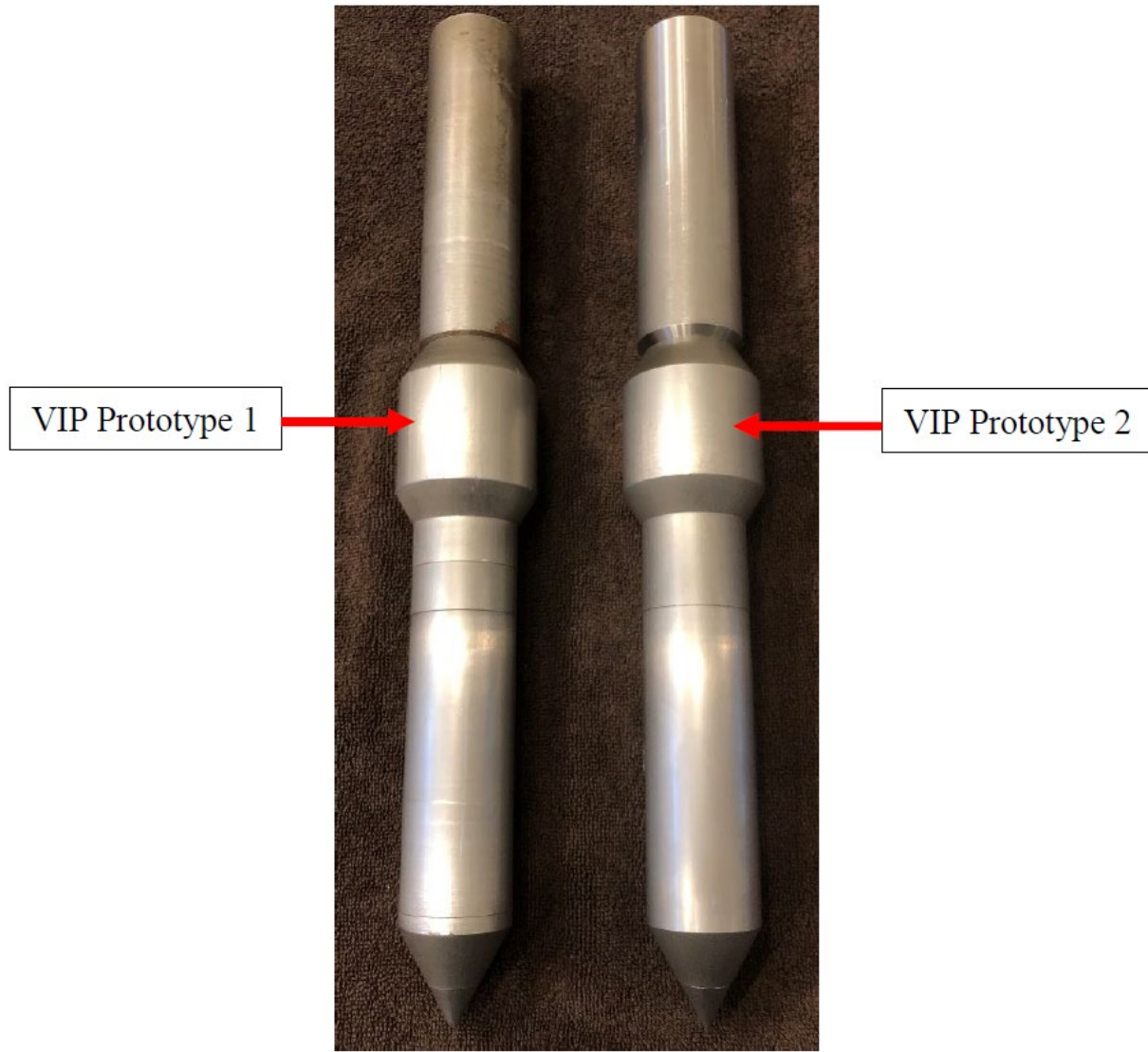

Figure 2-10. VIP Prototype 1 and 2 comparison displaying nearly identical exterior dimensions.

2.7 New Falling Head Vessel Design

In addition to the new probe design, a new falling head vessel was also designed and fabricated, Figure 2-11. The new design incorporates the following updated features:

- Aluminum plates used instead of steel (original) to reduce the weight for onsite transport,
- Greater wall thickness in falling head vessel to provide a more robust design,
- More robust tripod stand,
- All pieces are individual and removable which allows the vessel components to be more easily replaced if damaged.



Figure 2-11. New falling head vessel design, displaying removable pieces.

2.8 *VIP Probe and Falling Head Vessel Fabrication*

In total, eight VIP probes and falling head vessels were fabricated during the research effort. Figures 2-12 and 2-13 provide images of the probes and falling head vessels, respectively.



Figure 2-12. Eight new VIP probes.



Figure 2-13. Seven new falling head vessels (prototype not depicted).

2.8.1 *Production Cost per VIP Probe and Falling Head Vessel*

The following production costs are based on the pricing of fabrication from a local machine shop in Gainesville.

Table 2-1. VIP probe estimated fabrication costs.

Quantity		Unit Price	Total Price
	1	\$2,325.00	\$2,325.00
	3	\$2,060.00	\$6,180.00
	5	\$1,947.00	\$9,735.00
	7	\$1,680.00	\$11,760.00
	8	\$1,621.00	\$12,968.00

Table 2-2. Falling head vessel estimated fabrication cost.

Quantity	Unit Price	Total Price
1	\$1,987.00	\$1,987.00
3	\$1,725.00	\$5,175.00
5	\$1,480.00	\$7,400.00
7	\$1,320.00	\$9,240.00
8	\$1,275.00	\$10,200.00

2.8.2 *Fabrication Issues and Relevant Information in Regard to Fabrication*

The biggest issue with the fabrication process was the large underestimation for the lead time provided by the machine shop. The estimated lead time was 3.5 weeks, provided in the quote received. However, the total fabrication time for the probes was 14 weeks. The falling head vessels were fabricated in just over 12 weeks. The machine shop stated that they were having issues with cutting the AWJ threads on the probes. In order to ensure the threads were cut properly, the research team delivered an AWJ rod to be used as a template for threading. The threads were eventually cut properly and functioned well. Therefore, it is recommended to provide an AWJ rod to be used as a template to speed up the fabrication process.

Regarding the cost of fabrication, manufacturing seven probes and falling head vessels at the same time greatly reduced the cost per item. It was explained by the machine shop that the savings occurred due to only having to setup each fabrication machine a single time. Therefore, if the same number of probes and falling head vessels were contracted out but manufactured at different times, the only cost savings would have been from material costs and the price per probe would be similar to purchasing a single probe (i.e., \approx \$1,987.00) Therefore, it is recommended to manufacture multiple probes at the same time if multiple probes are to be fabricated.

3. VIP Probe Calibration

After each probe was constructed, each probe and accompanied equipment is calibrated to ensure they were functioning properly before distribution. This required standards to be developed to check the O-ring compression and to determine the permeability limits of the probe. The shape factor developed for the probe ($F = 3D$) was also investigated. Preliminary results using $F = 3D$ are included in this chapter but the shape factor investigation continued throughout the duration of the project.

3.1 Probe Mechanics

Before discussing VIP calibration procedures, it is important to discuss the probe mechanics of the newly designed Prototype 2 VIP probe. Figure 3-1 provides visualization the VIP probe's mechanics.

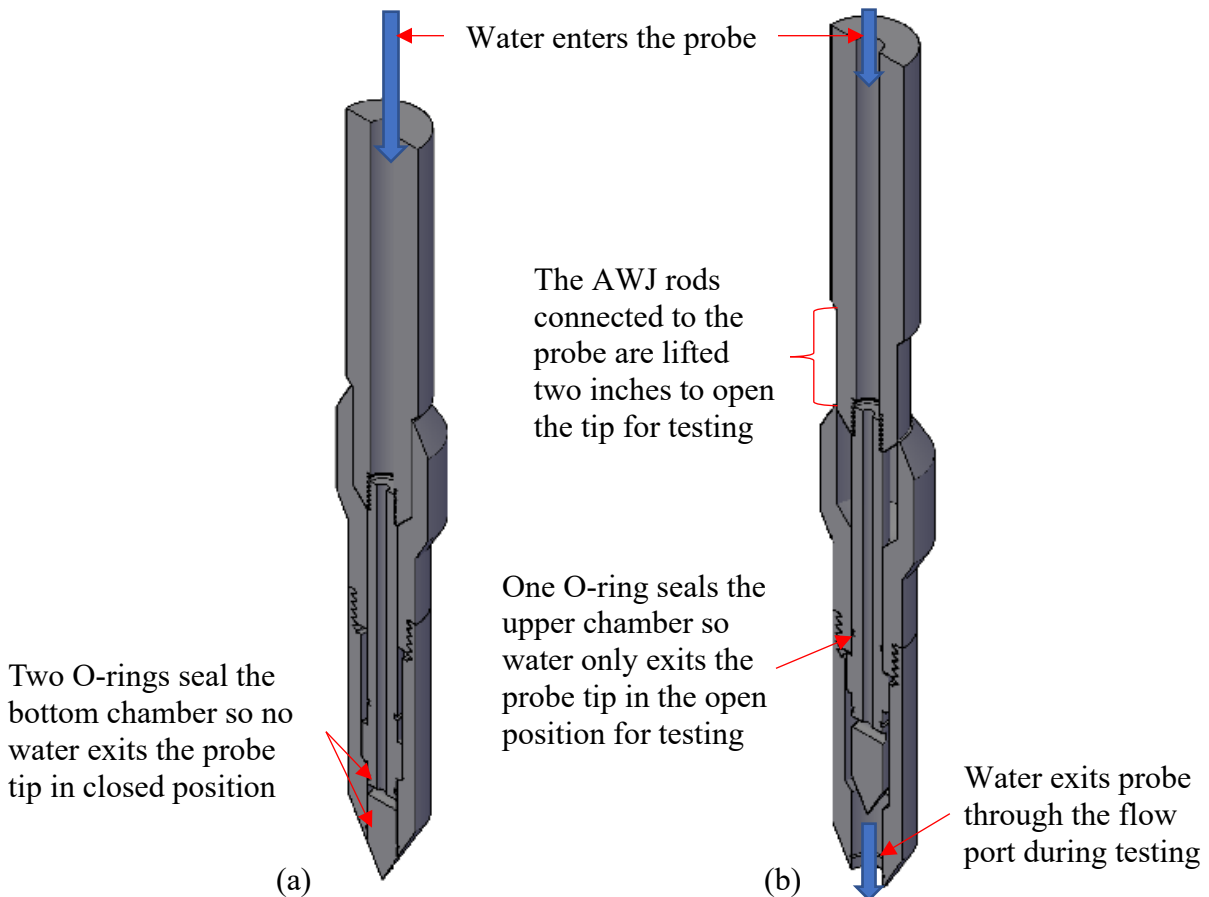

Figure 3-1. VIP probe mechanics displaying (a) closed position and (b) open position.

As depicted in Figure 3-1a, when the probe is in the closed position two O-rings located in the tip of the probe head seal the water from exiting into the soil and/or the main chamber prior to testing. The upper O-ring in the tip is located on the inner rod and the lower O-ring in the tip is located on the inner diameter of the probe head. The O-rings were strategically placed in both

locations to reduce resistance when opening and closing the probe. Placing both O-rings either on the inner rod or inside the probe head would have resulted in more resistance and greater force required to retract the inner rod during the vertical lift. The current configuration presented in Figure 3-1 ensures a quick release of resistance after minimal vertical lift.

Depicted in Figure 3-1b, the AWJ rods attached to the probe are lifted two inches at the surface which simultaneously retracts the probe tip to introduce flow into the soil and initiate testing. When the inner rod is retracted, the O-ring placed on the upper portion of the inner rod slides into the friction reducer providing a watertight seal. This ensures water only flows through the intended flow port at the tip of the probe which in return ensures the VIP's volume of water measurements are accurate. To clarify, the upper O-ring prevents water from escaping through the top of the probe which could produce false readings in less permeable soils. This is similar in nature to short circuiting that can occur in laboratory permeability testing with cohesive soils, where the water travels between the soil sample – soil chamber interface (path of least resistance) providing a false reading.

3.2 Developing VIP Calibration Standards

The function of the O-rings is to provide a watertight seal in the desired location in either the open or closed stages of the probe's operations. However, the resistance produced by the O-rings when either trying to open or close the probe must be considered. Therefore, a balance between providing a watertight seal and transitioning from the open and closed stages with minimal resistance needed to be evaluating for the new design. This required several O-rings sizes to be investigated to determine which O-rings provide the best seal while producing the least resistance in opening and closing the probe. This also required standards to be developed to quantify each O-ring function.

3.2.1 O-ring Compression Testing

The first calibration standard developed was for the O-ring compression which measures how easily the probe can be opened and closed. In the field, the test procedure involved locating a soil with low density which was quantified via SPT blow counts. For the field testing, the probe was tested in multiple locations where the blow counts ranged from the weight of the rod (WR) to $N = 3$. In all locations where the low-density soils were located, the new VIP design functioned as intended. In the WR location, one of the VIP permeability tests measured the highest average permeability recorded to date with any VIP probe, $k_m = 4.68 \times 10^{-2}$ cm/s. Sieve analysis from a sample collected at the site indicated a uniformly distributed soil (A-3 / SP) with only 3.6% fines passing the No. 200 sieve. Push tests in a nearby location indicated a measured axial force of 2,000 lbf at the same depth (5 ft), which is one of the lowest measurements recorded during the push tests. Based on the this testing, the following field calibration procedure was developed:

1. Perform SPT testing and identify a location with blow counts ranging from $N = WR$ to 3. Observations from push tests and SPT testing suggests 5 feet is an ideal target depth in a uniformly distributed cohesionless soil.
2. Perform VIP testing which requires the probe to be opened.

3. After testing, close the probe off, and observe the water level of the falling head vessel to ensure it stabilizes in a short period of time, generally within 1 to 5 minutes. This will ensure the probe has returned to the closed position in the loose soil.
4. With the soil now saturated, reopen the probe and observe the water level of the falling head vessel to ensure flow is occurring and the probe was opened again in the loosened soil.
5. Repeat step 3 to complete the test.

As it is not practical to always perform the field calibration procedure, a quick hand test was also developed which ensures the same O-ring compression. For the hand test calibration procedure:

1. Grip the probe by the AWJ connection and hold the probe with tip facing down, Figure 3-2a. When the internal components are dry, the probe will remain closed off. When the internal components are wet, the probe will slowly open under its own weight.
2. Open the probe (two inch lift) to initiate the upper inner rod O-ring seal within the friction reducer. Grip the AWJ connection with the probe tip facing upwards, Figure 3-2b. When the internal components are dry, the probe will remain open. When the internal components are wet, the probe will slowly close under its own weight.

Note: When the internal components are dry, the probe can be opened and closed by hand with some resistance. When the internal components are wet, the probe can be opened and closed under its own weight or by hand with minimal resistance.



Figure 3-2. O-ring compression hand calibration procedure displaying a.) the probe remaining closed supporting its own weight and b.) the probe remaining open supporting its own weight.

3.2.2 Watertight Seal Testing

The greatest depth at which VIP testing is likely to occur in the field is estimated to be 20 to 25 feet below ground surface. Therefore, the probe needed to be tested in a controlled environment to ensure a watertight seal is provided at 25 feet of head with O-rings that provide the desired probe functionality in soils with low density. The controlled testing was conducted on UF's main campus utilizing the exterior stairwell of Weil Hall to provide an elevation head of approximately 45 feet.

For the tests, the friction reducer was removed as depicted in Figure 3-3. This allowed the UF research team to observe the internal components of the probe for leaks. Two locations were investigated during testing: the internal threaded connection and the two O-rings that seal the probe head when in the closed position. The internal thread was investigated because it is located above the upper inner rod O-ring which seals the probe off during testing. If leaking occurred in this location, it could give a false reading as water may be released through the top of the probe. The bottom O-rings were investigated for two reasons. The first is to ensure the probe seals water from exiting the probe when in the closed position. The second is the upper inner rod O-ring provides the same seal as the lower inner rod O-ring. Therefore, if the lower O-ring holds a seal at the tip when closed, the upper O-ring inherently holds a seal in the friction reducer when the probe is in the open position during testing.

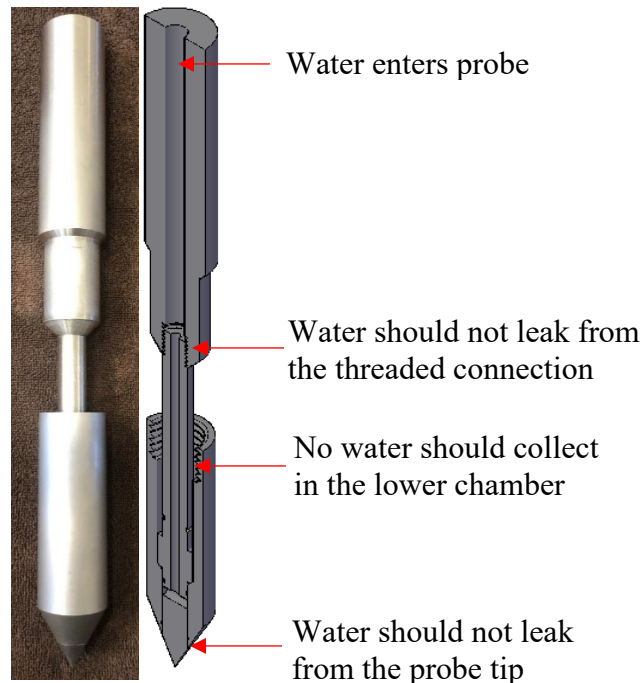

Figure 3-3. Watertight seal testing investigated locations.

The watertight seal testing is depicted in Figure 3-4. The tests were conducted with an approximate elevation head of 45 feet. When the first tests were conducted, PTFE tape was applied at the threaded connection. PTFE (plumbers) tape is commonly used to prevent leaks in

threaded pipe connections containing water under pressure. When the probe was tested without PTFE tape, some leaking did occur. Consequently, it is recommended to use PTFE tape at both threaded connections to ensure a watertight seal. Both O-rings in the tip of the probe head performed well as no leaks were observed at either location. This also ensures the upper inner rod O-ring seals water from exiting the top of the probe during the open position for testing. Based on the test observations, the probe provided a watertight seal at about 45 feet of head when PTFE tape was used at the threaded connections, which is approximately twice the head typically used for conventional testing. Note: Prior to the watertight seal testing, the O-ring compression hand test was conducted to ensure both calibration procedures coincide with one another.

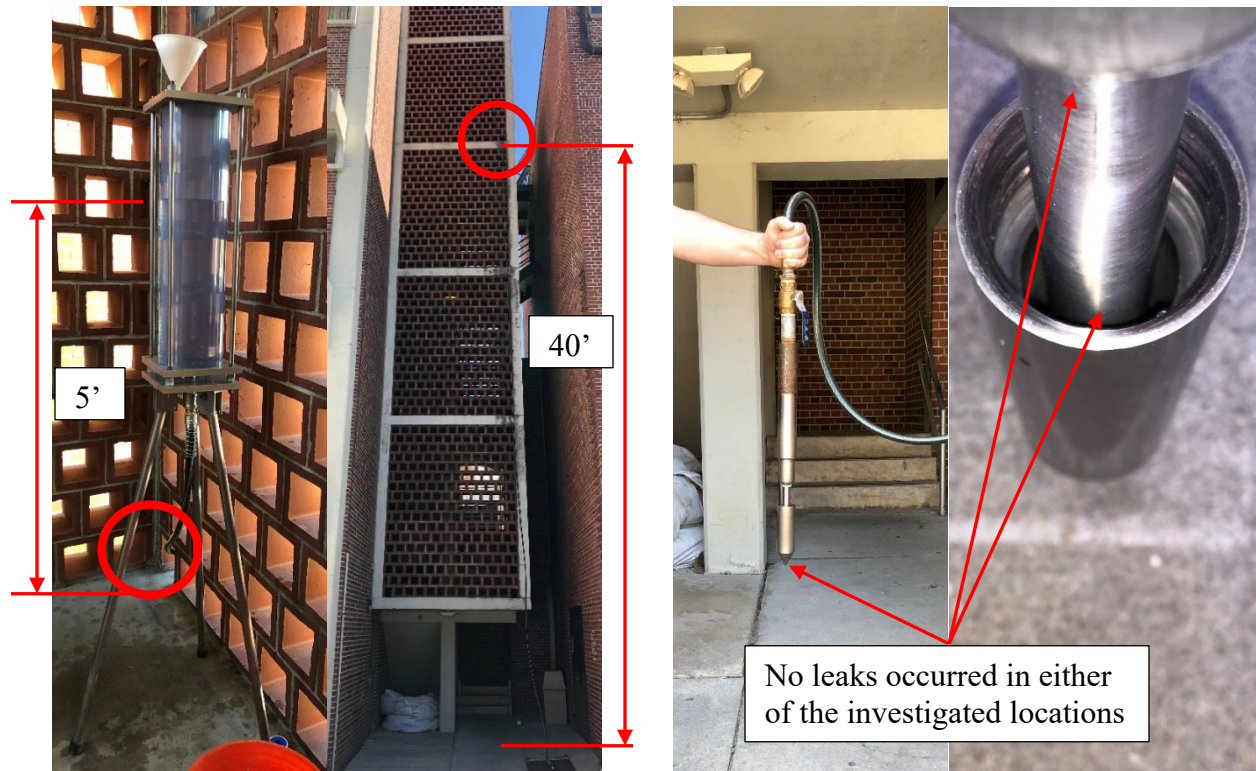

Figure 3-4. Watertight seal testing at approximately 45 feet of head.

Based on the results of the tests, the following calibration procedure was developed:

1. Remove the friction reducer from the probe assembly and place PTFE tape on the inner rod threaded connection,
2. Slide the probe head onto the inner rod and ensure the inner rod probe tip fully protrudes the probe head flow port (reflects the closed position),
3. Place PTFE tape on any AWJ connection that connects the probe to the falling head vessel to prevent leaking,
4. Introduce water to the probe at the highest desired free draining elevation (e.g., Figure 3-4) via the falling head vessel and ensure stabilization occurs in the water tank,

5. Inspect the threaded connection, the open chamber of the probe head, and the tip of the probe for leaks (See Figure 3-3).

3.3 Upper Permeability Limit

During VIP calibration, the upper permeability limit was tested as detailed in FM 5-614. Three tests were performed in which the probe was left to drain freely into the air to estimate the limiting flow rate and upper permeability limit of the VIP probe. Drainage of the water tank (14.38-cm inner diameter for the falling head vessel used) from 200.7 cm to 171.9 cm above the injection port of the probe took 47.2 seconds on average. Thus, an average injection head of 186.3 cm corresponds to an injection flow rate of 99.1 cm³/s. From this and knowing $F = 3D = 5.715$ cm ($D = 1.905$ cm, injection port diameter), a maximum conductivity $k_{\max} = 99.1 / (186.3 \times 5.715) = 9.31 \times 10^{-2}$ cm/s was achieved. Normalizing the result based on the water temperature and viscosity, $k_{m@20^{\circ}\text{C}} = k_m \times (\mu_{14.4^{\circ}\text{C}} / \mu_{20^{\circ}\text{C}}) = 9.31 \times 10^{-2}$ cm/s $\times (0.001153 \text{ N}\cdot\text{s}/\text{m}^2 / 0.001002 \text{ N}\cdot\text{s}/\text{m}^2) = 1.07 \times 10^{-1}$ cm/s. Therefore, $k_m = 1.07 \times 10^{-1}$ cm/s is recommended as the upper permeability limit. Above this value, the hydraulic resistance of the probe and hose would be larger than the hydraulic resistance of the aquifer, affecting the accuracy of the aquifer's permeability value. The upper permeability limit measured with the new probe design improved the upper permeability limit from the original VIP design where $k_{\max} = 7.48 \times 10^{-2}$ cm/s. The new upper permeability limit also closely reflects the threshold between a high and medium degree of permeability, $k_m = 1 \times 10^{-1}$ cm/s, according to Terzaghi and Peck (1967).

3.4 Lower Permeability Limit

Determining the lower permeability limit of the probe required a continuous investigation to be conducted throughout the research effort. However, during preliminary VIP testing and calibration procedures with the new design, the lowest permeability measurement to date was measured with the new probe, $k_m = 9.48 \times 10^{-6}$ cm/s. This, in combination with the highest permeability measurement recorded to date with the new probe, provided a wider range of measured permeability than the entire prior project (BDV31-977-23) at all four tested locations. This was an encouraging preliminary result for the new probe design prior to the large testing effort that took place throughout Florida. The lower permeability limit will be discussed again during field testing analyses.

3.5 Shape Factor Investigation – Preliminary Testing

During preliminary testing, the shape factor $F = 3D$ was also investigated for the new probe design. This investigation took place in Trenton where comparative cased constant head (CCH) borehole tests, push tests, and soil classification were also conducted. This section details the results and observations from the preliminary tests.

In Location 1, two VIP tests and one CCH test were performed at three different depths: 5, 10, and 15 feet. SPT testing was also conducted in the footprint of the CCH test location and soil samples were collected via a split spoon sampler. At 15 feet of depth in Location 1, sieve analyses from the collected samples indicated the soil type changed from an A-3 (SP) soil with less than 5% fines passing a No. 200 sieve to an A-2-4 (SM) soil with approximately 20% fines passing the No. 200 sieve, Figure 3-5. Measurements from both VIP tests and the CCH test

indicated the permeability changed approximately three orders of magnitude (Figure 3-6). In addition, both VIP tests were in agreement with the CCH test at each depth. This supports that a shape factor of $F = 3D$ is appropriate for the new probe design.

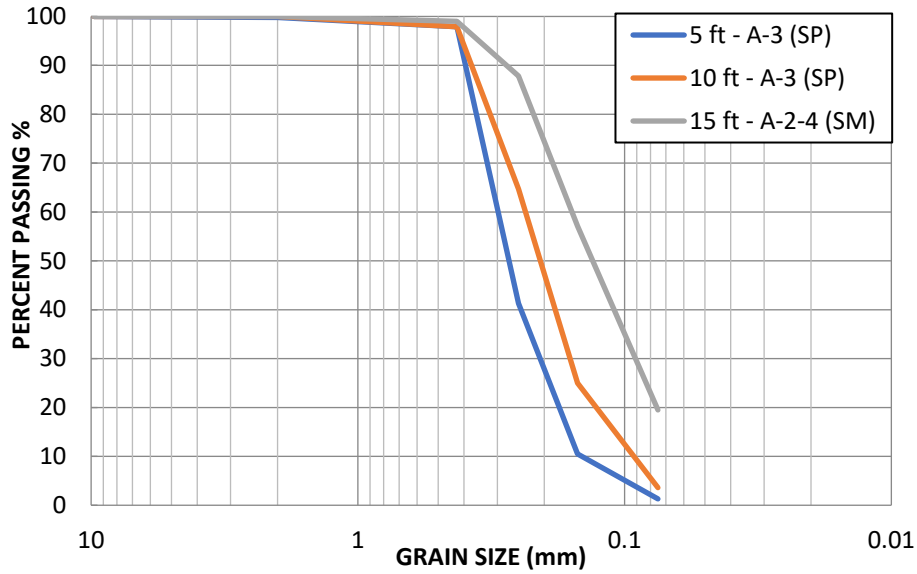

Figure 3-5. Sieve analyses from Location 1 in Trenton.

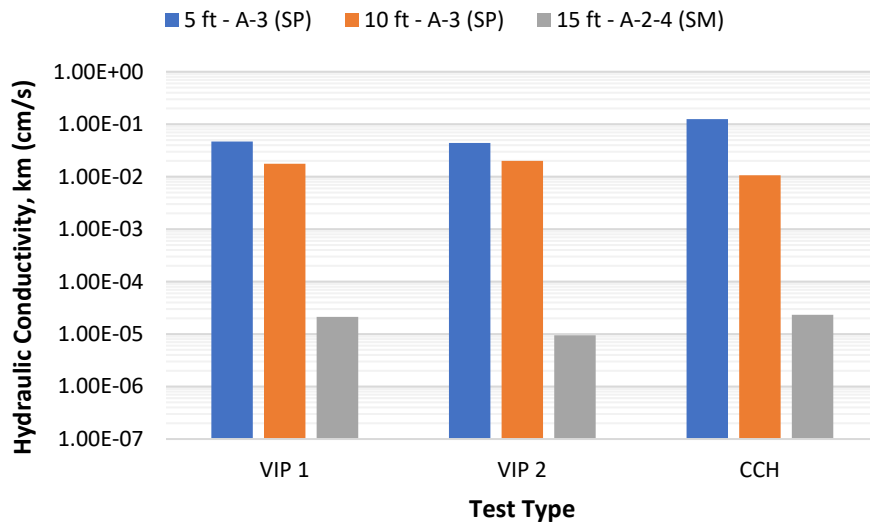

Figure 3-6. Permeability results from VIP and CCH at three depths in Location 1 in Trenton.

In Location 2, the soil type was identified to be A-3 (SP) at all three depths, Figure 3-7.

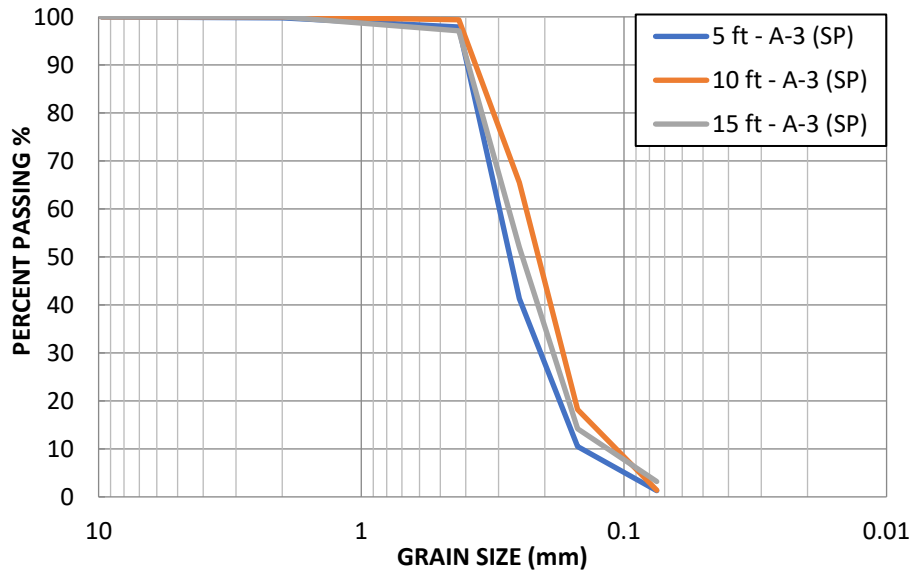

Figure 3-7. Sieve analyses from Location 2 in Trenton.

Push Tests were also conducted at Location 2 that indicated the soil density was increasing as the test depth increased, Figure 3-8.

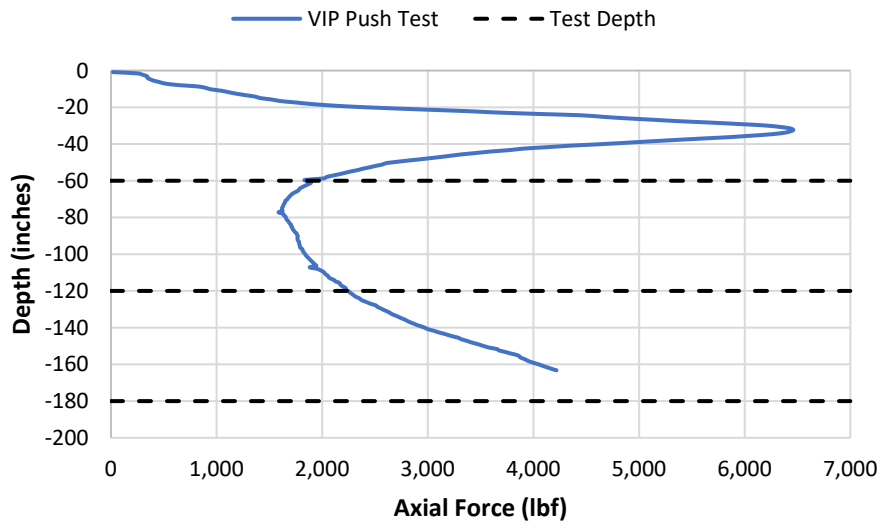

Figure 3-8. Push test results at Location 2 in Trenton.

Interestingly, both the VIP and CCH tests indicated the permeability decreased as the soil density increased, Figure 3-9. At test depths 5 and 10 feet, the VIP and CCH measurements were in good agreement. However, at 15 feet where the soil density largely increased compared to 5 and 10 feet, the CCH test resulted in a lower permeability measurement than the VIP test. This was thought to be a result of the CCH casing creating a denser soil state as it was advanced to the test

depth. In general, the CCH tests created more variability in the readings due to soil disturbance and the general test procedure, which is apparent when comparing VIP and CCH readings at 5 and 10 feet from the two locations where the same soil type was encountered with similar SPT blow counts. Although there was a slight disagreement between the VIP and CCH tests at one depth/location, the VIP results are encouraging and also support the use of $F = 3D$. However, similar to the lower permeability limit, the shape factor required a continuous investigation to be conducted throughout the research effort and will be discussed again during field testing analyses.

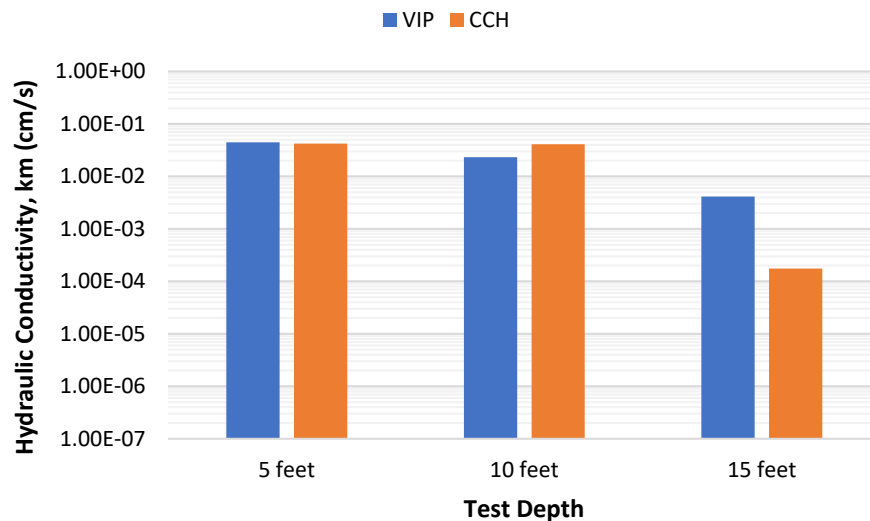

Figure 3-9. Permeability results from VIP and CCH at three depths in Location 2 in Trenton.

3.6 *VIP Calibration Observations*

The following observations were made during the VIP calibration procedures and preliminary testing:

- The new VIP probe design provided very consistent readings in the same soil type,
- The VIP measurements were in agreement with the conducted soil classification,
- VIP clearly indicated changes in soil type and drainage conditions,
- VIP indicated decreasing hydraulic conductivity when the density of the same soil type increased,
- VIP compared well with cased constant head borehole tests performed at the same locations,
- VIP provides less variable readings in the same soil type compared to the CCH tests. Soil disturbance from CCH casing advancement and predrilling likely creates more variability in hydraulic conductivity readings,
- Probe functionality with the new design is much improved compared to the old design,
- Engaging the probe in the open and closed positions at depth can be felt by hand at the top of the AWJ drill string. This will help field specialists ensure the probe is either fully opened for testing or fully closed for advancement,

- PTFE (plumbers) tape should be placed on both threaded connections of the VIP probe to ensure a watertight seal,
- The developed O-ring compression hand test provides a convenient method to ensure proper O-ring compression and watertight sealing is achieved,
- The watertight seal testing procedure provides visual confirmation that leaks do not occur.

4. Updating FM 5-614 and Creating a VIP Instructional Video

During the research effort, the original test method was updated to reflect the new probe design and to improve the test procedure. The new test method now provides much greater detail for how to properly perform the VIP test and an online instructional video was developed to provide further clarification of how the test is conducted. Also included in the new test method are updated CAD drawings that reflect the new probe design and falling head vessel. This allows anyone to take the CAD designs and have the VIP equipment manufactured at a local machine shop. This chapter includes the updated test method submitted by the UF research team to the FDOT and a brief overview of the VIP online tutorial.

4.1 *Scope*

This method describes the procedure to determine the mean coefficient of permeability in the field using the Vertical In situ Permeameter (VIP) probe.

4.2 *Apparatus*

- Vertical In situ Permeameter (VIP) Probe.
- SPT Drill Rig: AWJ Connections.
- Falling Head Vessel (Water Tank / Piezometer) with Hose Attachment.
- AWJ Hose Adaptor.
- Air Compressor with Tank (optional).
- Miscellaneous Equipment: tape measure, stopwatch, copper grease sealant, PTFE tape, dry erase marker, chalk, temperature gun or thermometer.

4.3 Probe Mechanics

Closed Position – No Flow

Water enters probe

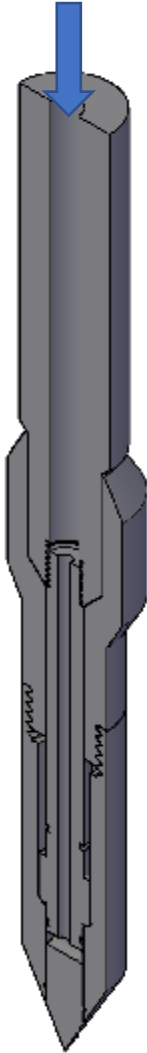

O-rings seal the probe tip to ensure no water exits while in the closed position

Open Position – Flow

Water enters probe

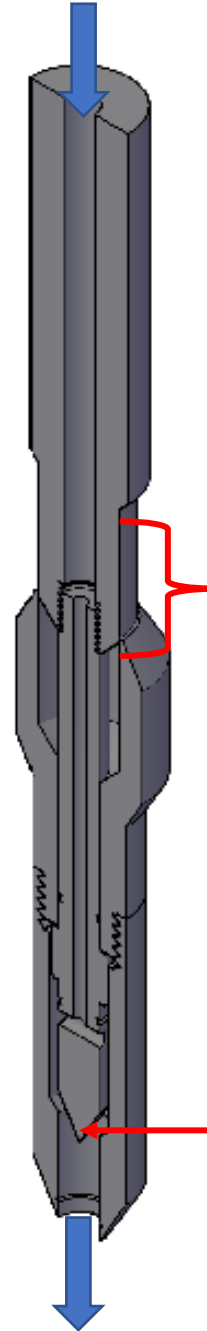

Lift 2 inches

Probe tip retracted

Water exits probe

Figure 4-1. VIP probe mechanics.

4.4 Procedure

1. Place PTFE (Plumbers) tape on threaded probe connections. Assemble probe. Assembly steps are covered in Steps 2 through 5.

Note: The smaller threaded connection (interior) requires 3 layers of PTFE tape, and the larger threaded connection (exterior) requires 4 layers of PTFE tape to ensure leakage does not occur.

2. Arrange probe parts A through D.

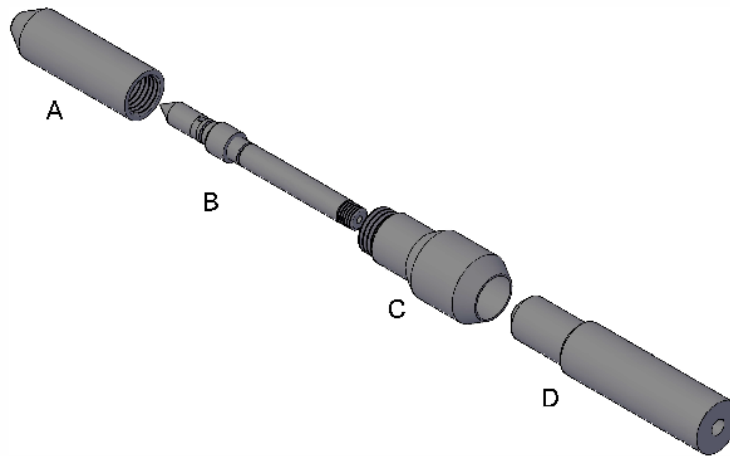

Figure 4-2. Step 1 of probe assembly.

3. Slide part C onto part B.

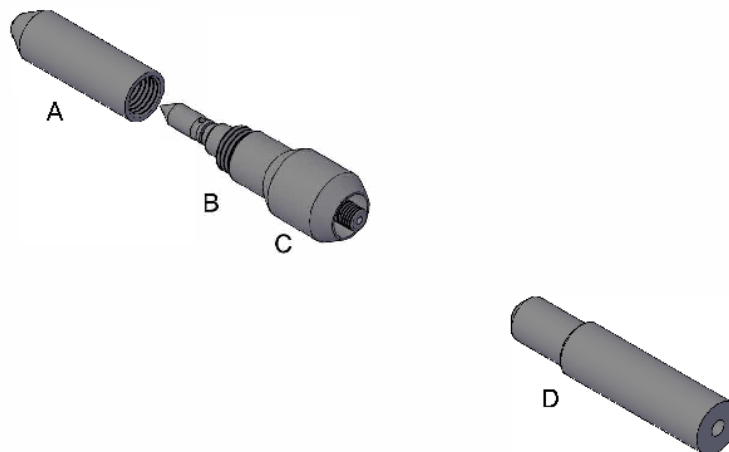

Figure 4-3. Step 2 of probe assembly.

- Slide part D into part C and thread onto part B using clockwise rotation.

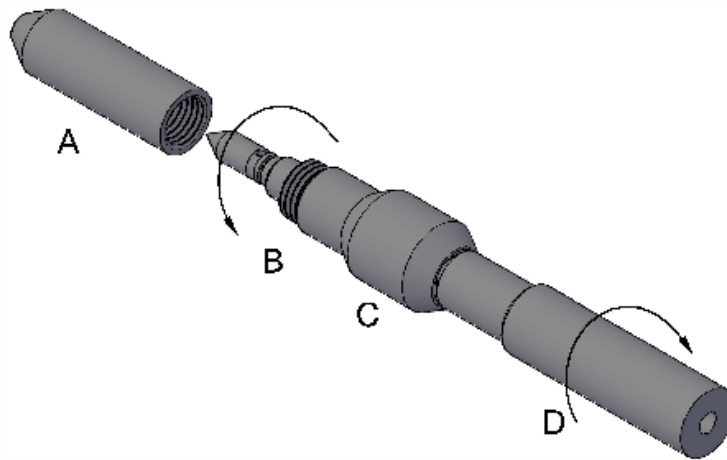

Figure 4-4. Step 3 of probe assembly.

- Thread part A onto part C using counter-clockwise rotation.

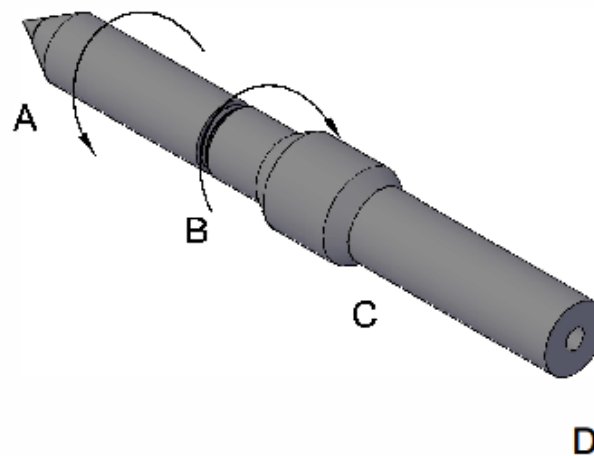

Figure 4-5. Step 4 of probe assembly.

Note: When threading part A onto part C, it is recommended to retract the inner rod as depicted in Figure 4 to reduce O-ring resistance during rotation.

- Thread probe onto the first AWJ rod that is attached to the drill rig. It is recommended to place thicker PTFE tape (gas line tape – typically yellow) on this threaded connection. A grease sealant, such as copper grease, can be used as an alternative to the PTFE tape.
- Advance probe to desired test depth using the SPT rig's direct-push technique.

8. Place grease sealant between threaded AWJ rod connections.
9. During probe advancement, several AWJ rods may be required to achieve the desired test depth. The length of the probe and AWJ rods used should be measured to ensure the probe tip is advanced to the desired test depth. The final AWJ rod should be marked with chalk in two locations. The first chalked location provides a reference between the ground surface elevation (GSE) and the total rod length (probe and AWJ rods) required to reach the desired test depth. The second chalk mark is placed 2 inches below the ground surface chalk mark and is used to track vertical movement of the probe when transitioning between the open and closed positions.

Note: When direct-push is not viable, pre-drilling might be necessary. Stop drilling a minimum of 1 foot prior to final testing depth and direct push the probe to the desired depth. Ensure probe is closed before advancement (electric tape can be used to ensure the probe remains closed during open borehole advancement which will be discussed later in this report).

10. Once the desired test depth has been achieved, fill the AWJ rods with water and remove any air voids prior to attaching the falling head vessel hose connection. Once the AWJ rods have been filled, the water level inside the rods should stabilize. If stabilization does not occur, either air voids are still present, the probe is not fully closed off, or water is leaking from an AWJ rod threaded connection. Stabilization should be achieved prior to running a test. Failure to achieve stabilization prior to testing may result in erroneous measures of hydraulic conductivity.
11. Attach AWJ hose adaptor to the top of the AWJ rods, fill with water, and remove any air voids.
12. Fill the falling head vessel with water. Allow water to freely drain from the attached hose to ensure all air voids are removed prior to attaching the AWJ hose adaptor.
13. Attach the hose from the falling head vessel to the AWJ hose adaptor.
14. Ensure the water hose is not kinked restricting flow.
15. Allow water to flow into the AWJ rods. Add additional water, as necessary. After adding any water, ensure the water level in the falling head vessel has stabilized.
16. Attach SPT rig cable hook to the AWJ rod above the ground surface.
17. Slowly lift the AWJ rod at the ground surface 2 inches using the attached SPT cable hook to open the probe for testing. Use the chalk marks (Step 9) to track the 2-inch vertical movement. The cable hook should remain in place throughout testing to ensure the probe remains stationary in the fully open position.

18. Let water drain for 15 minutes to ensure the soil is saturated. Add additional water to the falling head vessel, as necessary. When testing soils with higher permeability, attaching a continuous supply of water to the falling head vessel may be necessary. Measure the water temperature with a thermometer and record on the data sheet. After 15 minutes of saturation, the testing can begin.

Note: The total test time and recording increments to be used during the actual VIP test should be estimated based on the flow observed during the 15-minute saturation period. The initial water temperature should be compared to the final water temperature recorded at the end of testing.

19. Begin test. Start stopwatch when water level is at a readable mark. See Figure 4-11 for recording time and total length of test. Use a dry erase marker to mark the water level on the tank for each reading at the predetermined recording increments.
20. Once the testing has been completed, ensure that a sufficient supply of water is available in the falling head vessel to continuously flush the probe while transitioning to the closed position. This may require a continuous water supply to be attached to the falling head vessel for probe flushing. Measure the water temperature with a thermometer and record on the data sheet.
21. While system is flushing, remove SPT cable hook and push down 2 inches to close the probe. The ground surface chalk mark (Step 9) should now be at ground level again. Check the falling head vessel water level has stabilized which ensures the probe has been returned to the closed position.

Note: Compressed air can be used to assist in flushing the probe for certain soil types. This may be required if fat clays or low plasticity cohesive soils in a liquid state are continuously encountered. In most cases the water head from the falling head vessel is sufficient to properly flush the probe.

22. Disconnect water hose from AWJ hose adaptor.
23. Remove AWJ hose adaptor from top of AWJ rods.
24. The probe is now ready to be pushed to the next test depth.

Note: If procedural errors occur that may affect further testing results (e.g., the VIP was unable to be properly closed off and the water tank level never stabilized), extract the probe from the ground, disassemble, clean, reassemble, and then advance the probe to the next test depth.

4.5 Calculations

$$k_m = \frac{\pi d^2}{4F(t_f - t_i)} \ln \frac{H_i}{H_f}$$

Where:

- k_m = mean permeability (L/T)
- d = piezometer (water tank) inner diameter (L) ≈ 5.70 -in ≈ 14.5 -cm
- D = vertical flow port diameter (L) = 0.75-in = 1.905-cm
- F = Hvorslev (Case C) shape factor = $3D$ (L) = 5.715-cm
- t_i, t_f = initial and final time of test, respectively (T)
- H_i, H_f = initial and final water head, respectively (L)

Note: The piezometer inner diameter may vary slightly due to manufacturing defects. For the most accurate results, precise piezometer inner diameter measurements should be taken.

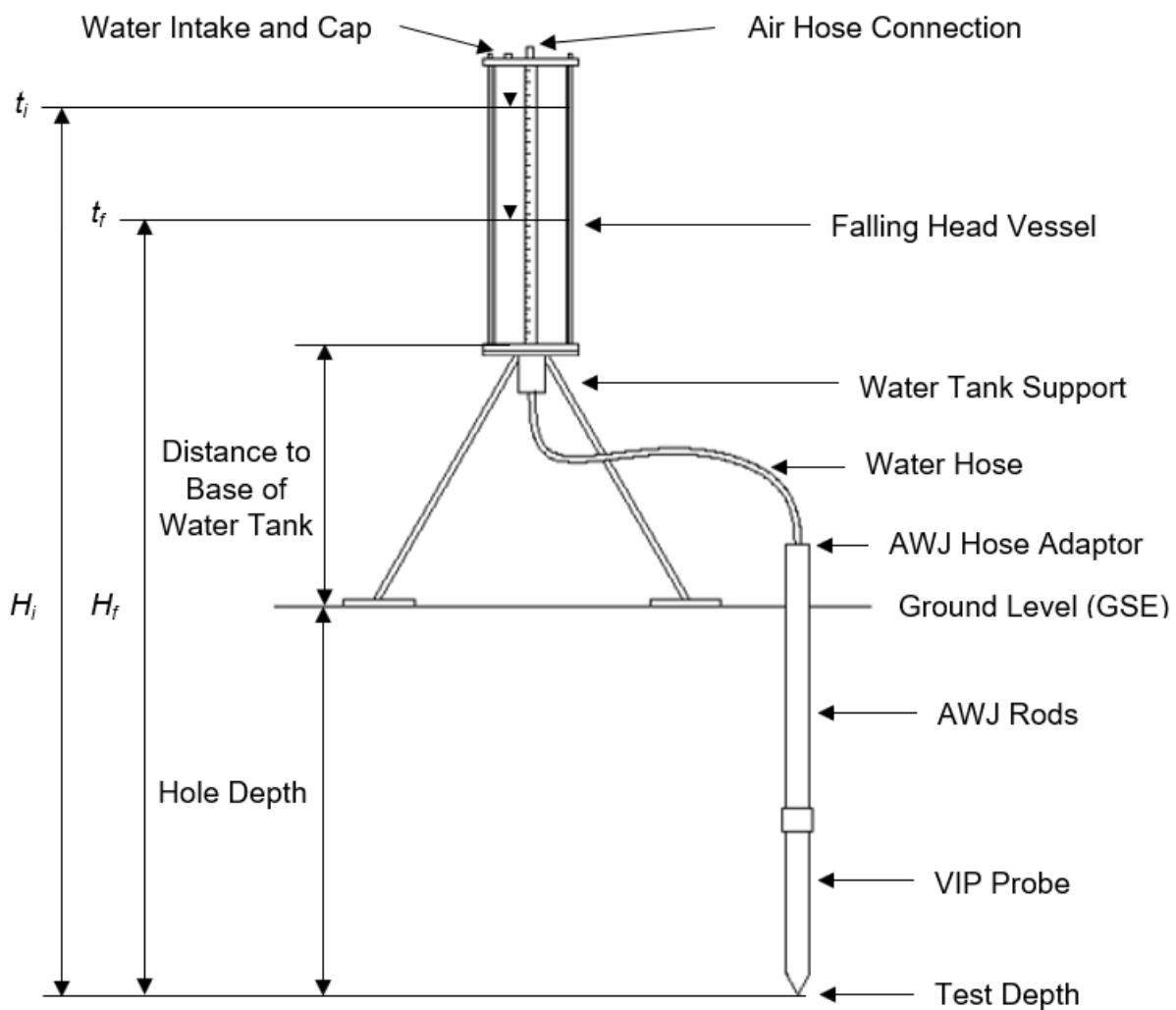

Figure 4-6. VIP test setup and measurements for mean permeability calculations.

Note: When the ground water table (GWT) is above the test depth, the ground water head above the test depth should be subtracted from the initial and final head used to calculate the mean permeability.

4.6 *Upper Permeability Limit*

During VIP calibration, the upper permeability limit was tested as detailed in FM 5-614. Three tests were performed in which the probe was left to drain freely into the air to estimate the limiting flow rate and upper permeability limit of the VIP probe. Drainage of the water tank (14.38-cm inner diameter for the falling head vessel used) from 200.7 cm to 171.9 cm above the injection port of the probe took 47.2 seconds on average. Thus, an average injection head of 186.3 cm corresponds to an injection flow rate of 99.1 cm³/s. From this and knowing $F = 3D = 5.715$ cm ($D = 1.905$ cm, injection port diameter), a maximum conductivity $k_{\max} = 99.1 / (186.3 \times 5.715) = 9.31 \times 10^{-2}$ cm/s was achieved. Normalizing the result based on the water temperature and viscosity, $k_{m@20^{\circ}\text{C}} = k_m \times (\mu_{14.4^{\circ}\text{C}} / \mu_{20^{\circ}\text{C}}) = 9.31 \times 10^{-2}$ cm/s $\times (0.001153 \text{ N}\cdot\text{s}/\text{m}^2 / 0.001002 \text{ N}\cdot\text{s}/\text{m}^2) = 1.07 \times 10^{-1}$ cm/s. Therefore, $k_m = 1.07 \times 10^{-1}$ cm/s is recommended as the upper permeability limit. Above this value, the hydraulic resistance of the probe and hose would be larger than the hydraulic resistance of the aquifer, affecting the accuracy of the aquifer's permeability value. The upper permeability limit measured with the new probe design improved the upper permeability limit from the original VIP design where $k_{\max} = 7.48 \times 10^{-2}$ cm/s. The new upper permeability limit also closely reflects the threshold between a high and medium degree of permeability, $k_m = 1 \times 10^{-1}$ cm/s, according to Terzaghi and Peck (1967).

4.7 Equipment Checklist

4.7.1 VIP Probe Equipment Checklist

<u>Equipment Checklist</u>			
VIP ASSEMBLY:			
Item	Inspection	In	Out
Probe	<ul style="list-style-type: none"> - Clean with wire brush - Threading - O-rings 		
Probe Maintenance Set	<ul style="list-style-type: none"> - Wire brush - Extra O-rings 		
VIP Probe AWJ Connection	<ul style="list-style-type: none"> - Soil and/or organic debris - Loose PTFE tape / Excess grease 		
AWJ Hose Connection	<ul style="list-style-type: none"> - Loose PTFE tape / Excess grease 		
Water Vessel w/ Cap	<ul style="list-style-type: none"> - Cap (top of water tank) - Nuts to secure to stand - Leaking at connections 		
Support Stand	<ul style="list-style-type: none"> - Loose connection components 		
Water Hose – Probe / Tank Connection	<ul style="list-style-type: none"> - Connection leaks 		
Portable Air Compressor w/Tank	<ul style="list-style-type: none"> - Pressure 		
Air Hose	<ul style="list-style-type: none"> - Quick connections 		
Tank Tape Measure	<ul style="list-style-type: none"> - Alignment and bonding - Old markings from test readings 		
Stopwatch	<ul style="list-style-type: none"> - Proper functionality 		
Temperature Gun / Thermometer	<ul style="list-style-type: none"> - Measure temperature of test water 		
Clipboard			
Data Sheet w/ Pen	<ul style="list-style-type: none"> - Extra - Thin dry eraser marker for water tank 		

Figure 4-7. VIP assembly checklist.

4.7.2 SPT Rig Equipment Checklist

<u>Equipment Checklist</u>			
SPT RIG:			
Item	Inspection	In	Out
AWJ Rods	<ul style="list-style-type: none"> - Multiple lengths - Leaks at connections 		
Grease Sealant	<ul style="list-style-type: none"> - Properly seals connections 		
Water Source	<ul style="list-style-type: none"> - 3 gallon water tank * # of tests 		
Water Hose	<ul style="list-style-type: none"> - Connects drill rig / external water supply to falling head vessel 		
Air Compressor	<ul style="list-style-type: none"> - Pressure - Instead of portable 		
Electrical Source (for rig w/o comp. air)	<ul style="list-style-type: none"> - 450 W 		
Chalk	<ul style="list-style-type: none"> - Visibility on AWJ 		
Water Level Indicator & Hand Auger	<ul style="list-style-type: none"> - If pre-drilling is not required (no hole) 		

Figure 4-8. SPT rig equipment checklist.

4.8 VIP Test Setup

SETUP:	
Task	Description
Probe	<ul style="list-style-type: none"> ▪ Assemble probe <ul style="list-style-type: none"> - Add PTFE tape and ensure threaded connections are tight ▪ Attach probe to SPT rig, use grease sealant between the AWJ connections
Water Supply	<ul style="list-style-type: none"> ▪ Setup support stand and secure water tank <ul style="list-style-type: none"> - Place on level ground where it will not interfere with testing - Ensure water hose for probe will reach - Ensure water hose to fill tank will reach ▪ Attach water hose to base of water tank <ul style="list-style-type: none"> - Place end of hose on top of water tank to prevent flow if a shut-off valve is not present ▪ Fill water tank
Air Supply	<ul style="list-style-type: none"> ▪ If using air compressor on SPT rig → adjust air pressure to proper level <ul style="list-style-type: none"> - Attach air hose and place near water tank ▪ If using portable air compressor → attach to electrical source and fill air tank <ul style="list-style-type: none"> - Adjust air pressure to proper level - Attach air hose and place near water tank
Misc.	<ul style="list-style-type: none"> ▪ Have data sheets and pen attached to clipboard <ul style="list-style-type: none"> - Multiples - Thin dry erase marker for water tank ▪ Check stopwatch ▪ Have tape measure and chalk ready

Figure 4-9. VIP test setup list.

4.9 VIP Test Breakdown

BREAKDOWN:	
Task	Description
Probe	<ul style="list-style-type: none"> ▪ Remove AWJ connection from top of drill string ▪ Remove probe from soil <ul style="list-style-type: none"> - Disconnect AWJ rods ▪ Clean probe with water and compressed air if necessary <ul style="list-style-type: none"> - Open/close probe to ensure smooth transitions
Water Supply	<ul style="list-style-type: none"> ▪ Drain water tank away from pathways <ul style="list-style-type: none"> - Ensure cap is tight ▪ Disconnect water hose from base of water tank <ul style="list-style-type: none"> - Coil ▪ Remove water tank from support stand ▪ Breakdown support stand
Air Supply	<ul style="list-style-type: none"> ▪ Disconnect air hose from air compressor <ul style="list-style-type: none"> - Coil ▪ Turn off air compressor
Misc.	<ul style="list-style-type: none"> ▪ Make sure all data sheets/pen are together and attached to clipboard <ul style="list-style-type: none"> - Ensure data sheet is filled out completely <ul style="list-style-type: none"> • Date, time, weather conditions, etc. ▪ Collect stopwatch, tape measure, and chalk ▪ Use checklist to ensure all equipment is packed for next location

Figure 4-10. VIP test breakdown.

4.10 Supplemental Information

<u>Supplemental Information</u>				
Testing Times Based on Soil Type and Flushing Recommendations*.				
Testing Recommendations (Estimate during saturation)			Flushing Recommendations (If needed, typically not required)	
Soil Type	Recording Increment	Total Length of Test	Air Pressure	Flush Time
Coarse Sand	15 – 30 sec	3 – 5 min	10 – 20 psi	10 sec
Fine Sand	30 sec – 1 min	5 – 10 min	15 – 25 psi	10 – 30 sec
Silty Sand	30 sec – 1 min	5 – 10 min	20 – 30 psi	10 – 30 sec
Sandy Silt	1 – 5 min	10 – 50 min	25 – 35 psi	10 – 30 sec
Clay	5 – 15 min	45 - 60 min	30 – 45 psi	30 sec – 1 min

*Numbers in this table are general approximations and will vary based on actual soil type and field conditions. Proper discretion should be used when selecting values. Initial saturation can be used to estimate appropriate values for recording increments and the total length of the test. The air pressures and flushing times are estimates based on flushing trials completed during development. Typically, pressurized flushing is not necessary. Water tank is rated for 90-psi but it is not recommended to pressurize the tank to this pressure.

Figure 4-11. VIP supplemental information.

4.11 VIP Data Sheet

<u>Data Sheet</u>			
Site Information:			
Date			
Project Location			
Tested By			
Weather/Notes			
Borehole Information:			
Hole No.		Drill Depth (ft) – for pre-drilled hole	
Station – Offset			
Test No.		Hole Diameter (in)	
Hole Depth (ft)		Water Temperature (°C or °F) – circle	
Water Table (ft)			
Distance to Base of Water Tank (in) – measured from ground surface			
Test Information:			
Reading No.	Time (sec or min) – circle	Height in Water Tank (in)	
Start	0		
1			
2			
3			
4			
5			
6			
7			
8			
19			
10			
11			
12			
13			
14			
15			
Other:			

Figure 4-12. VIP data sheet.

4.12 Shop Drawings

4.12.1 VIP Probe

Probe Layout

- A. Nose Cone
- B. Inner Rod
- C. Friction Reducer
- D. AWJ Connector

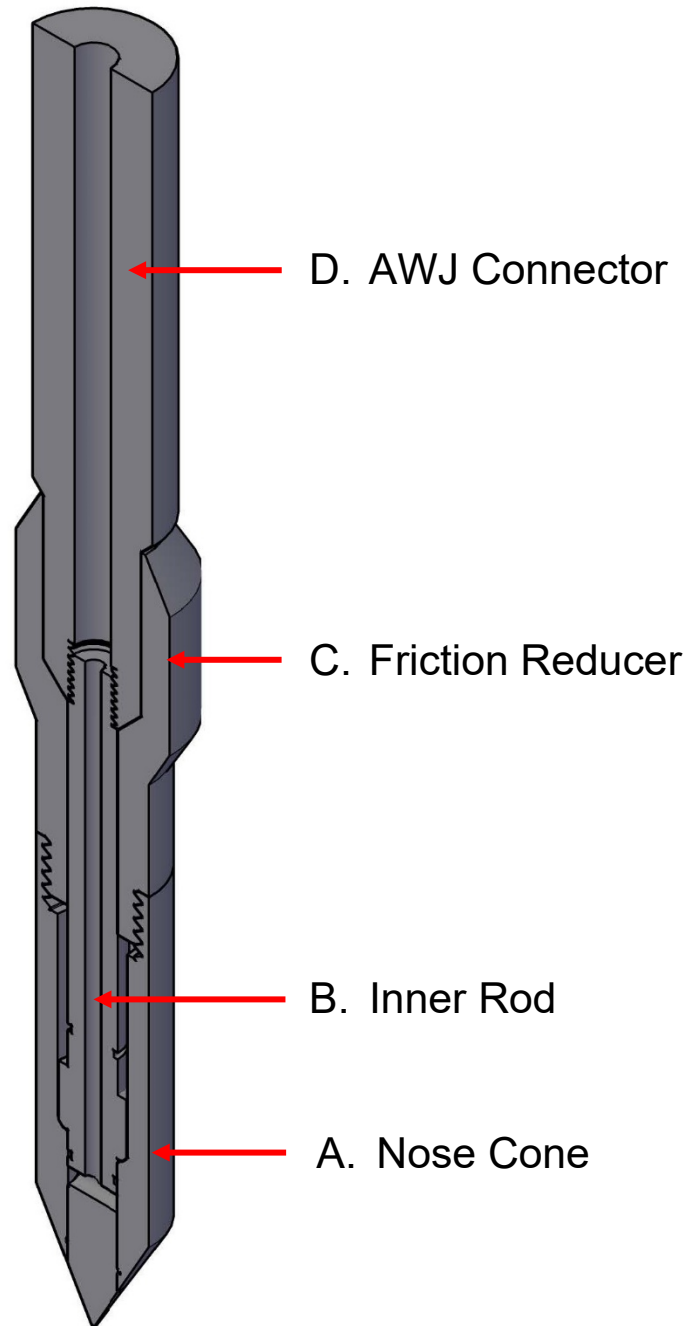

Figure 4-13. Probe layout.

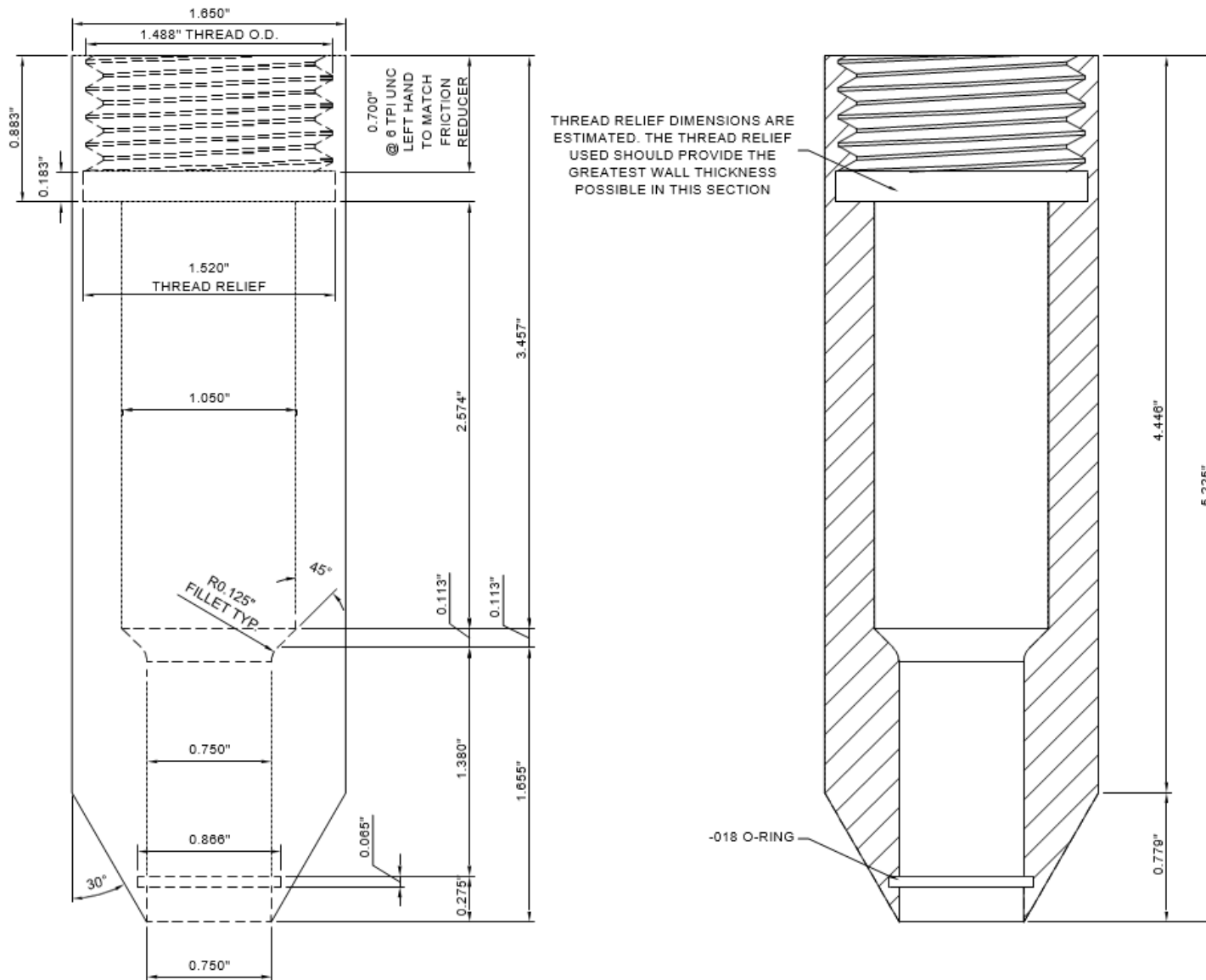

Figure 4-14. Nose cone.

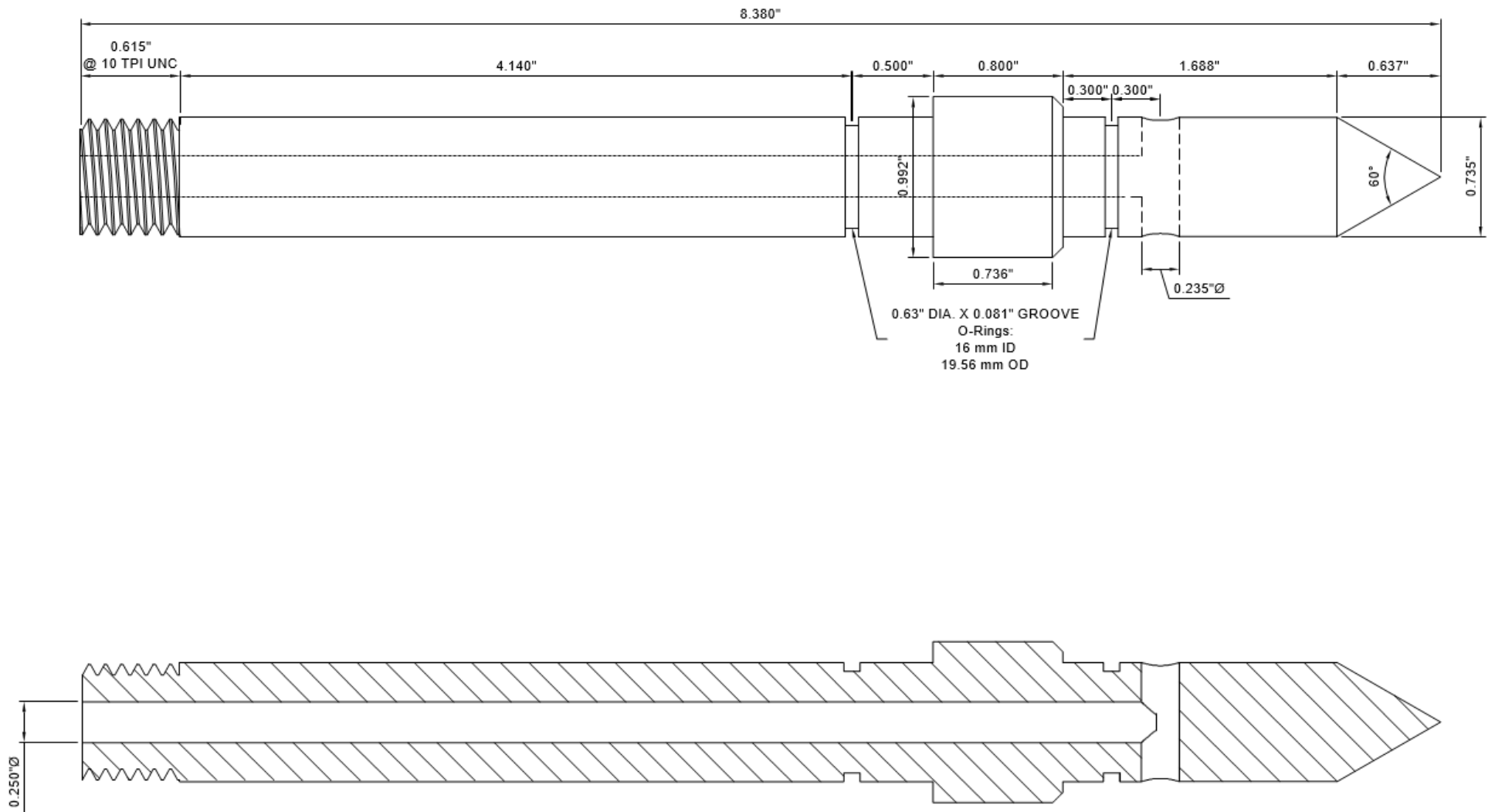

Figure 4-15. Inner rod.

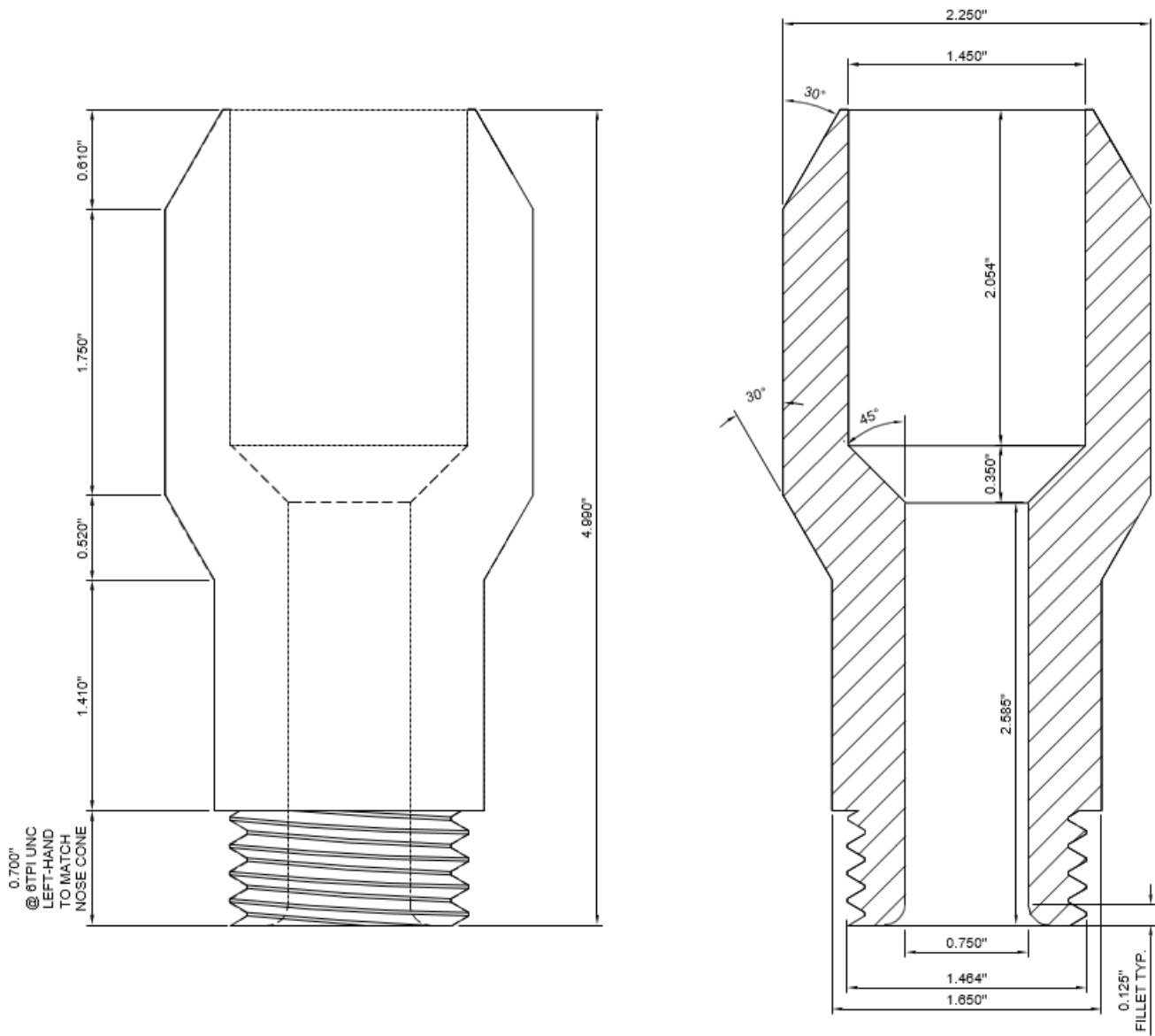

Figure 4-16. Friction reducer.

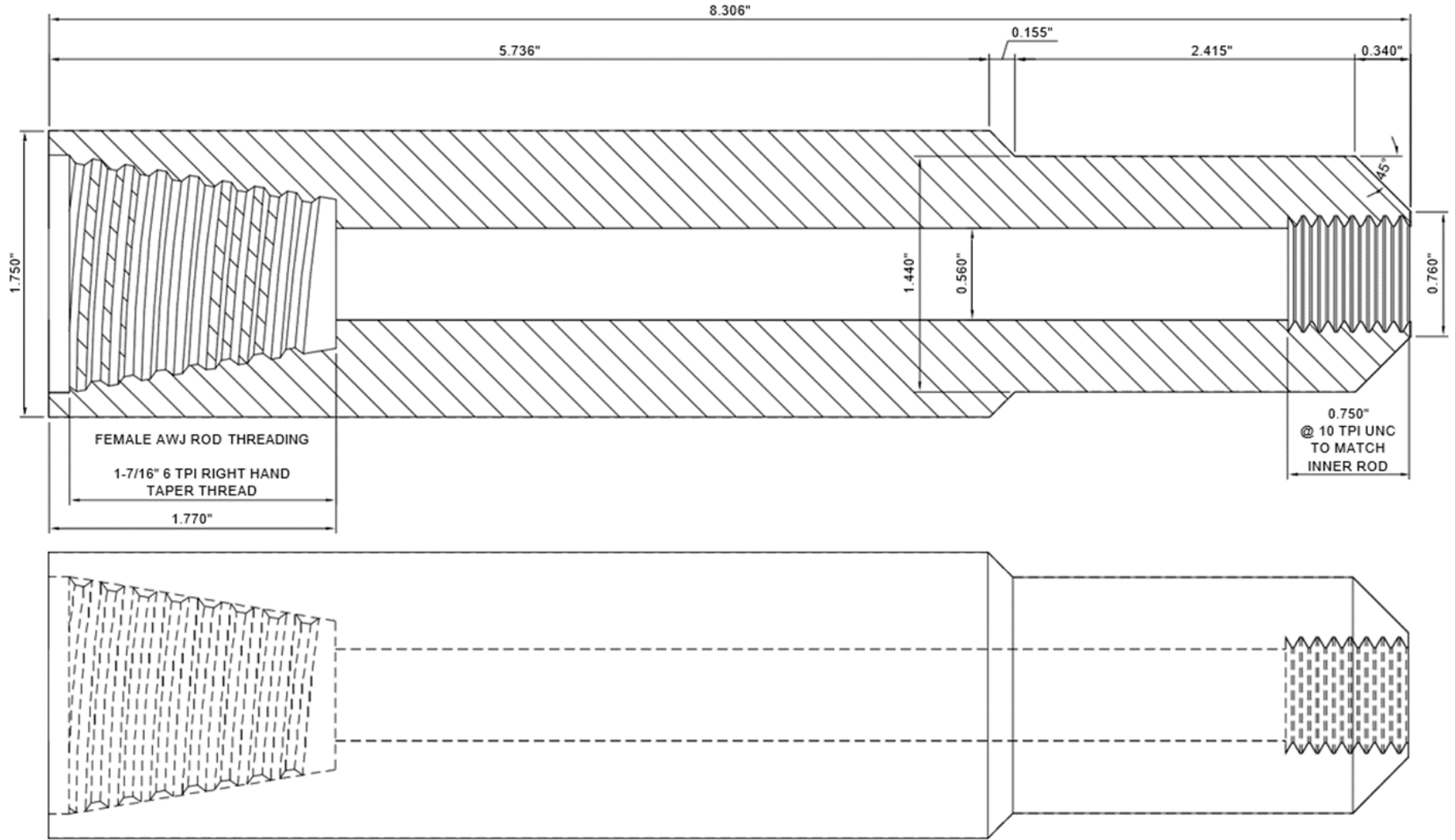

Figure 4-17. AWJ connector.

4.12.2 *Falling Head Vessel*

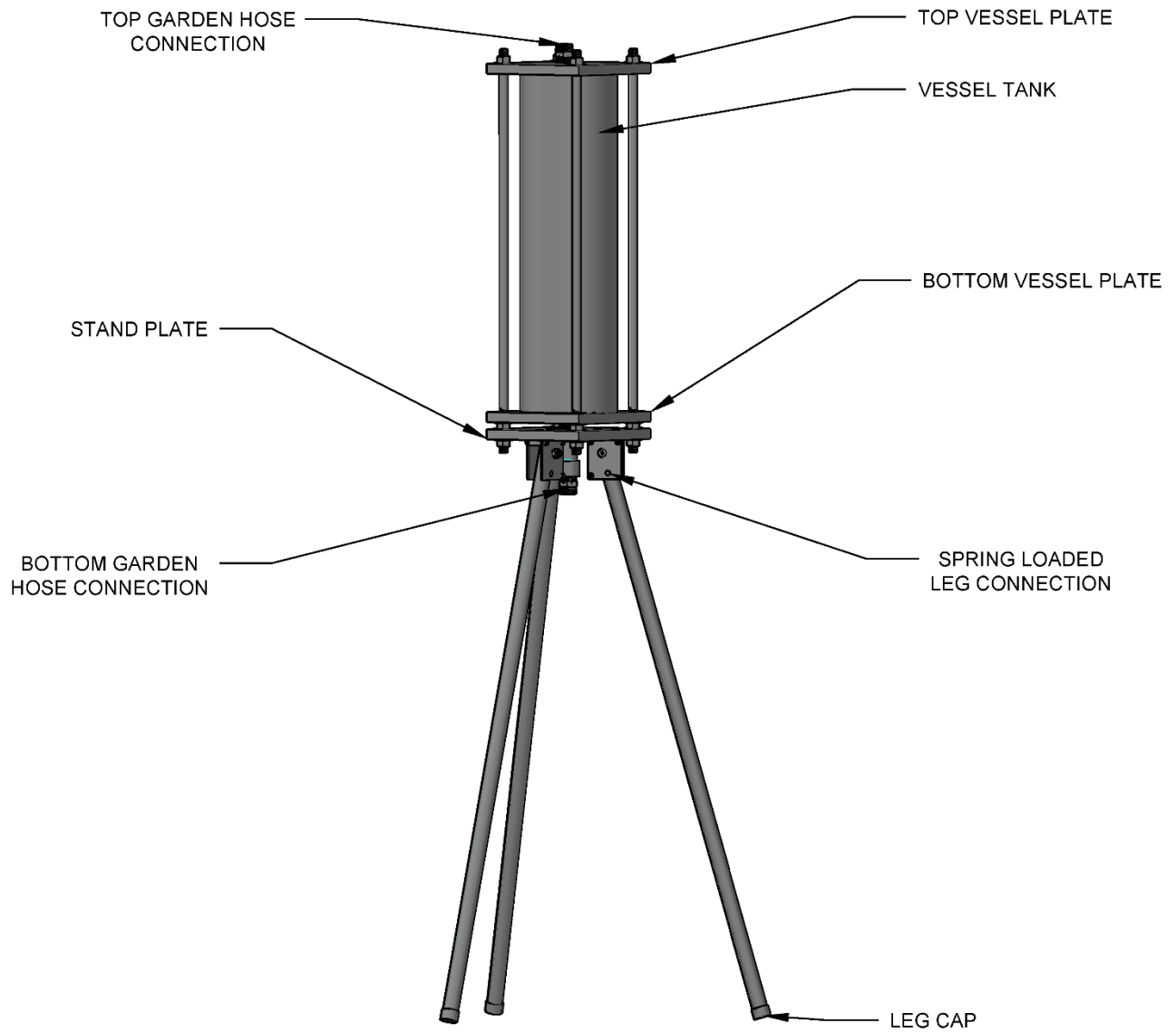

Figure 4-18. Falling head vessel overview.

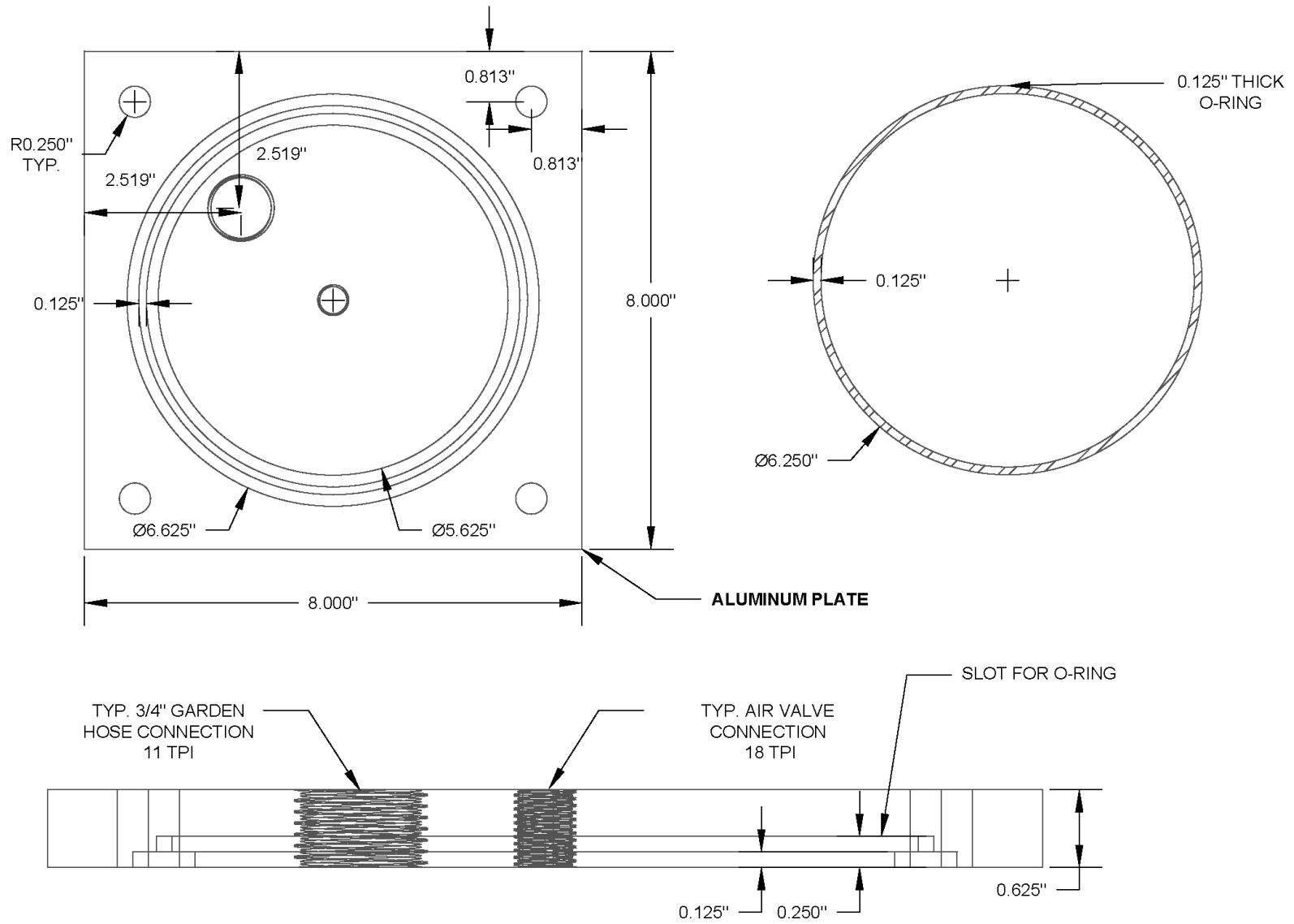

Figure 4-19. Top vessel plate.

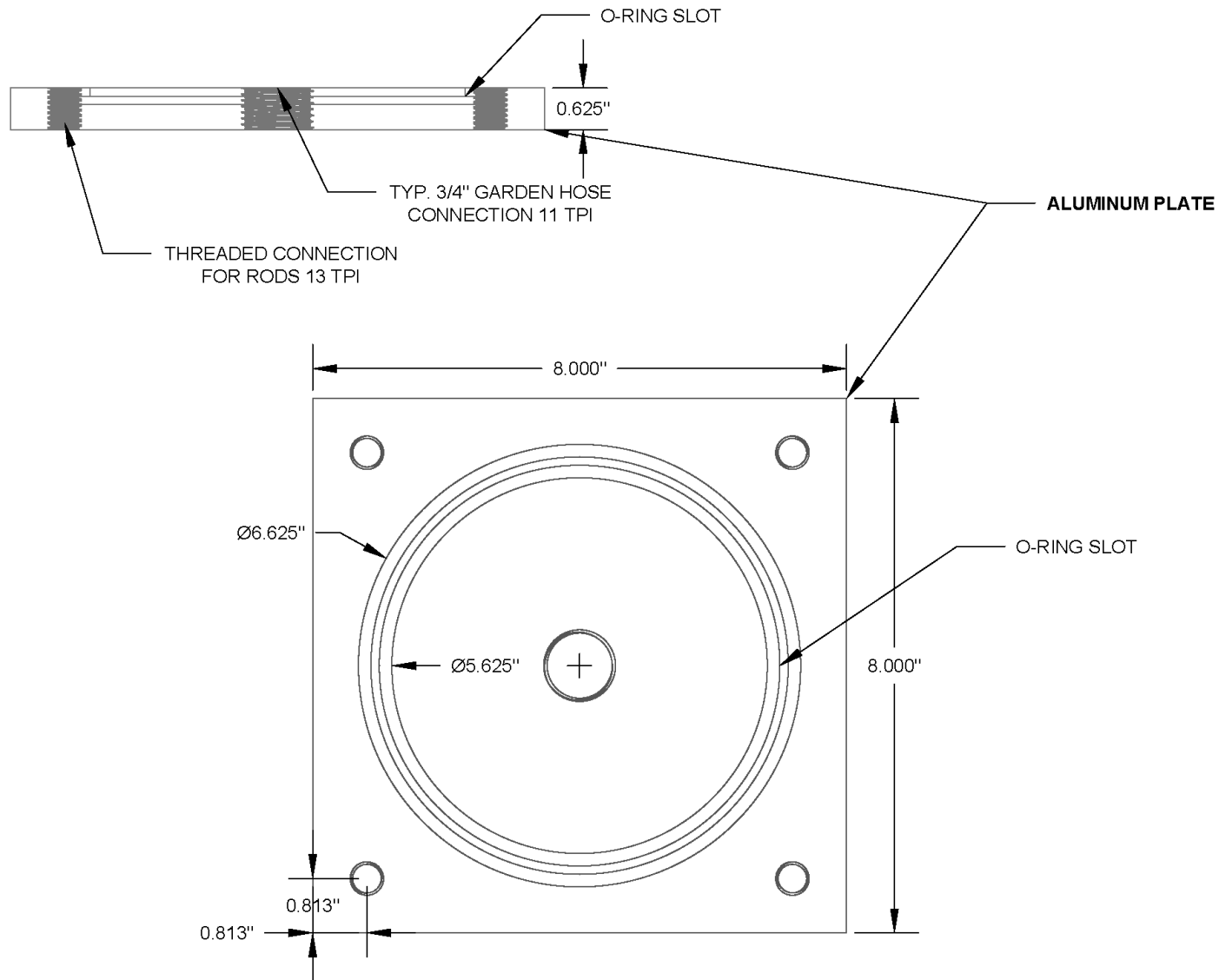

Figure 4-20. Bottom vessel plate.

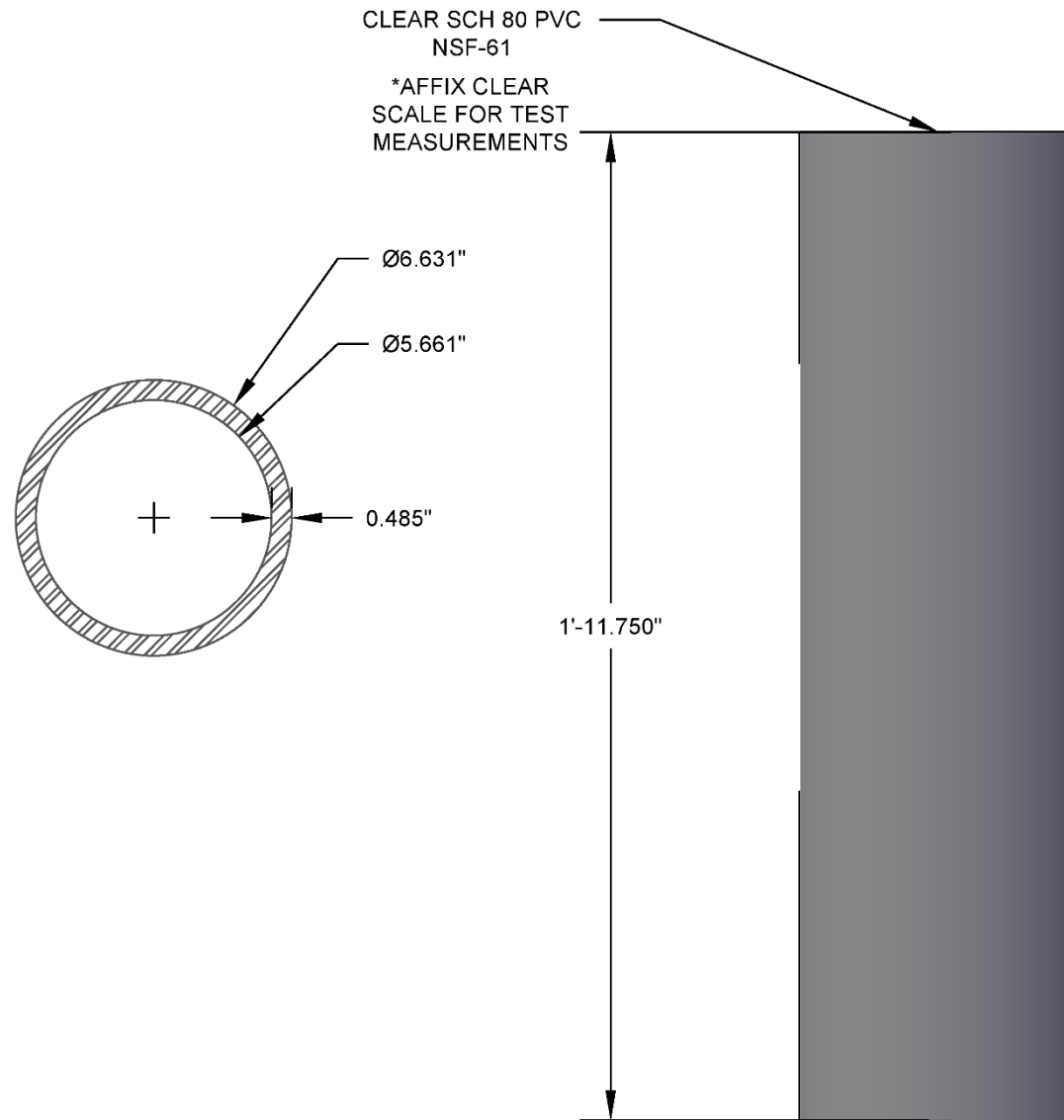

Figure 4-21. Falling head vessel tank (piezometer).

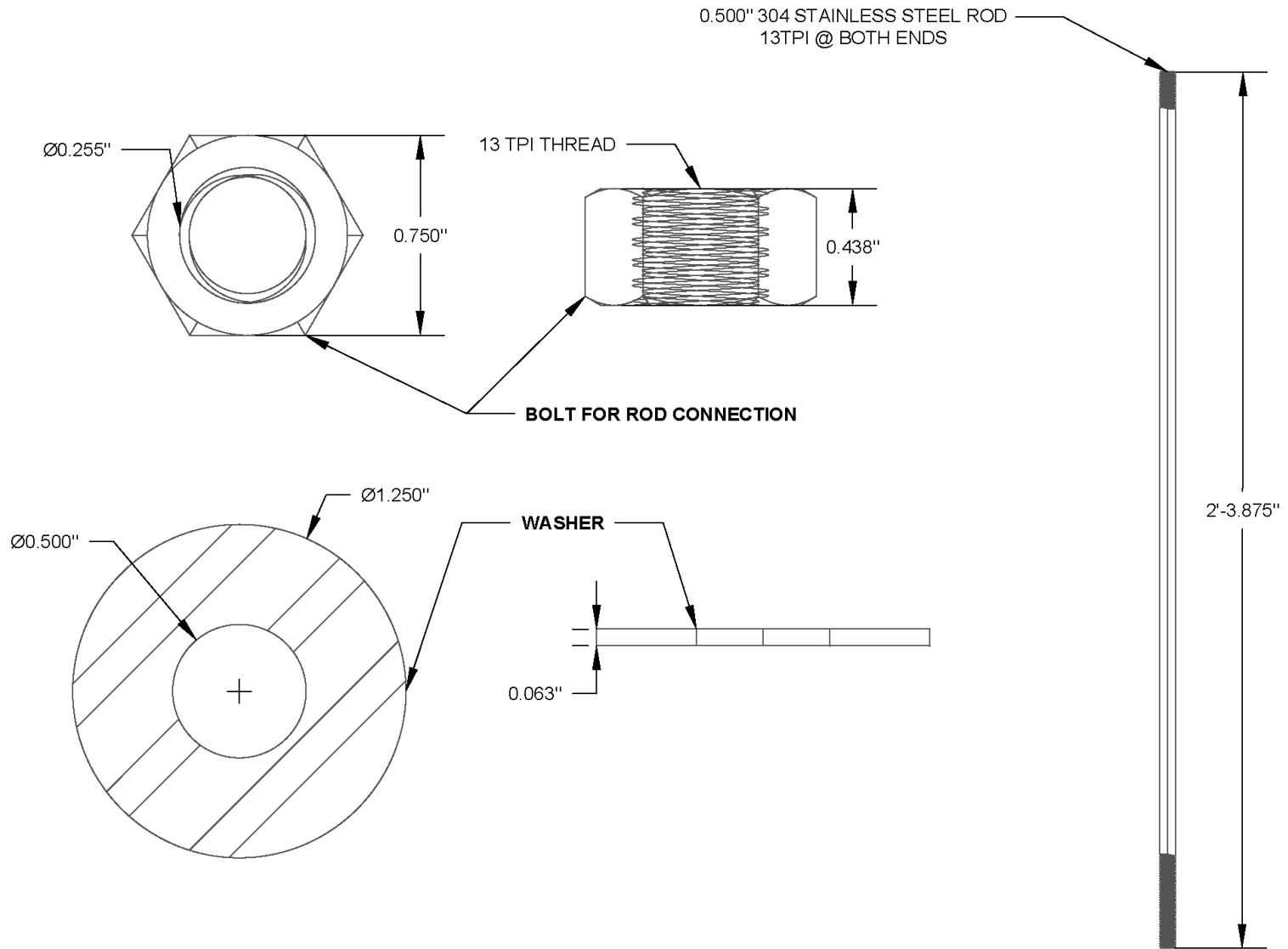

Figure 4-22. Threaded rods, bolts, and washers.

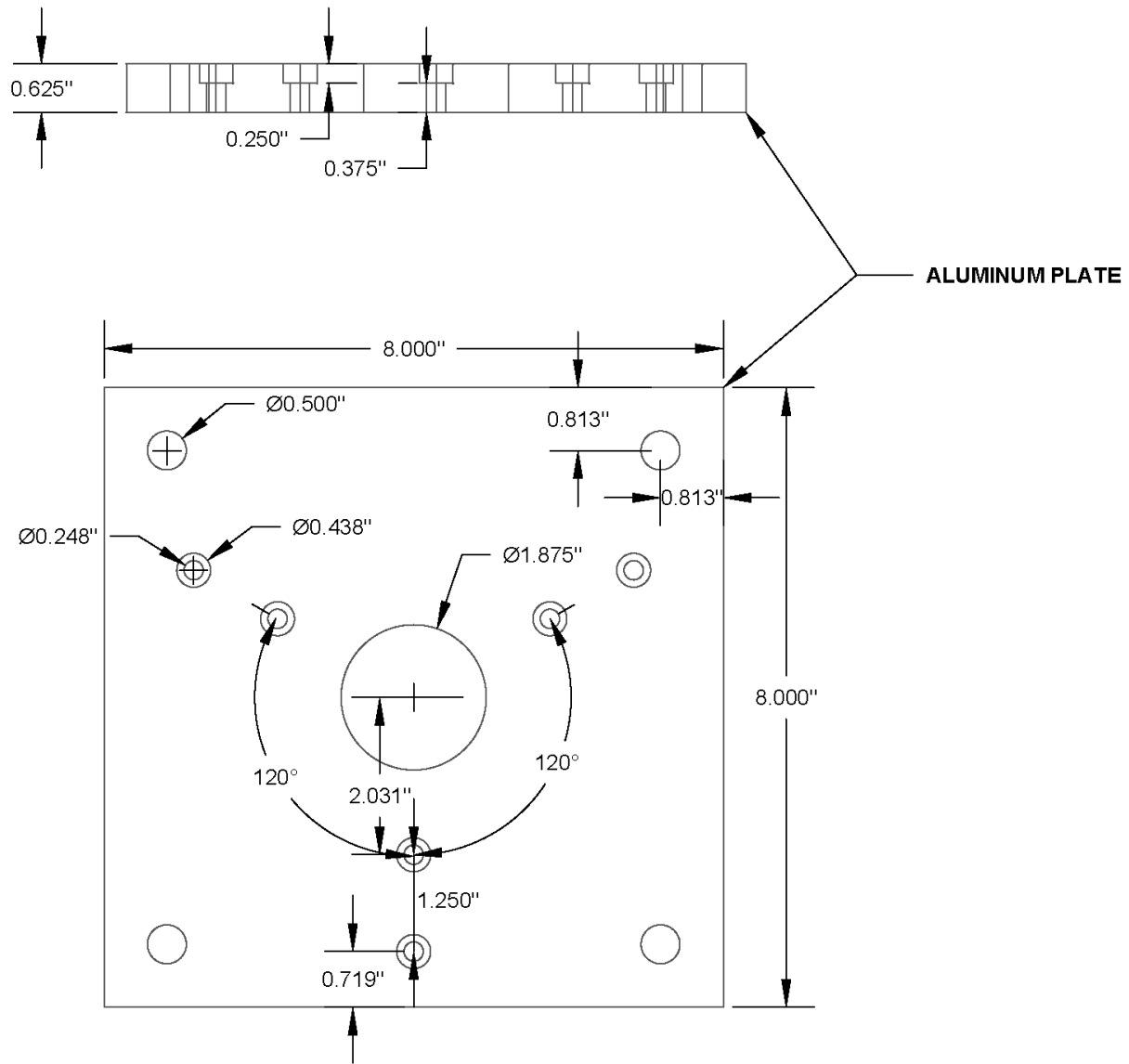

Figure 4-23. Stand plate.

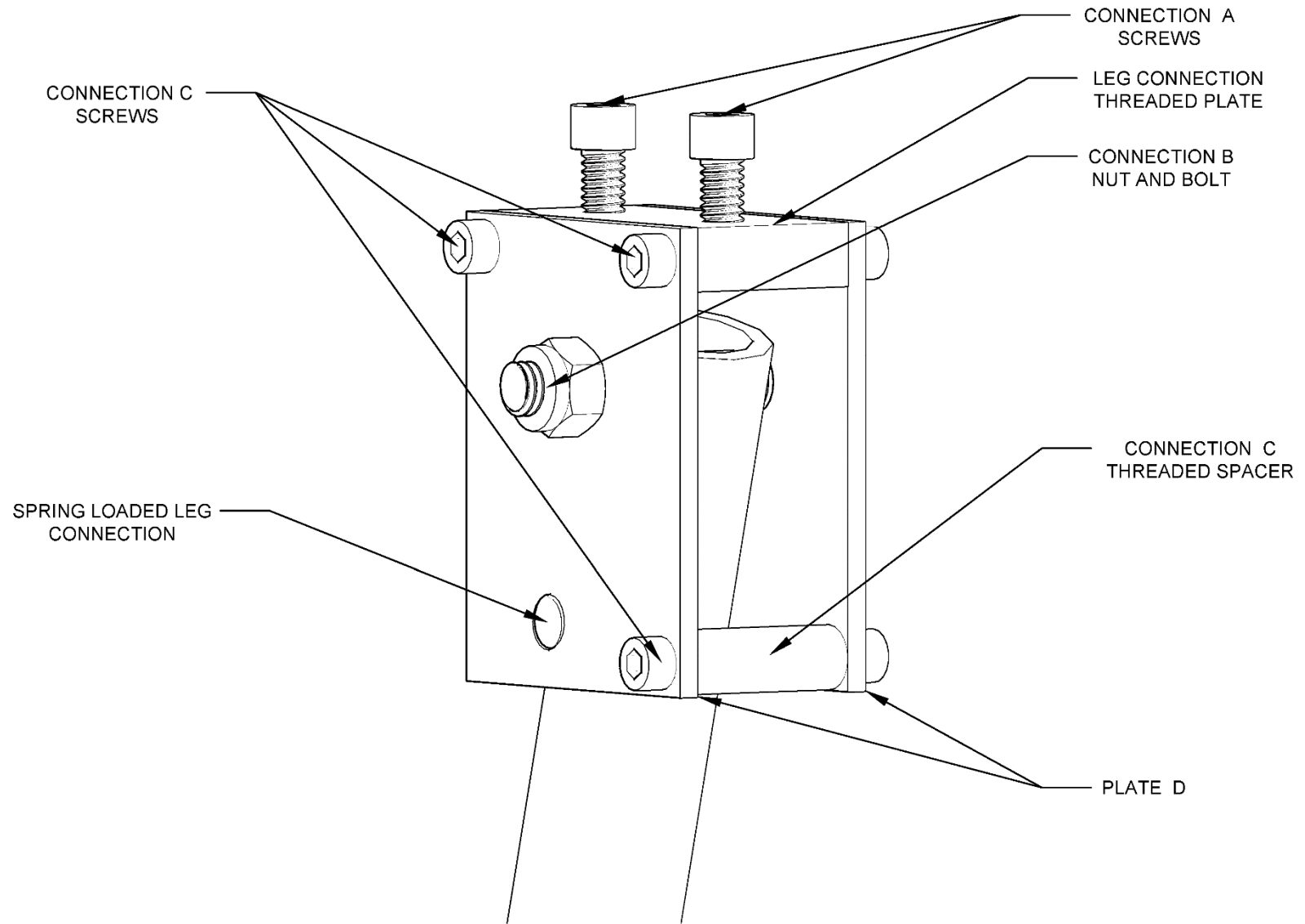

Figure 4-24. Leg connection overview.

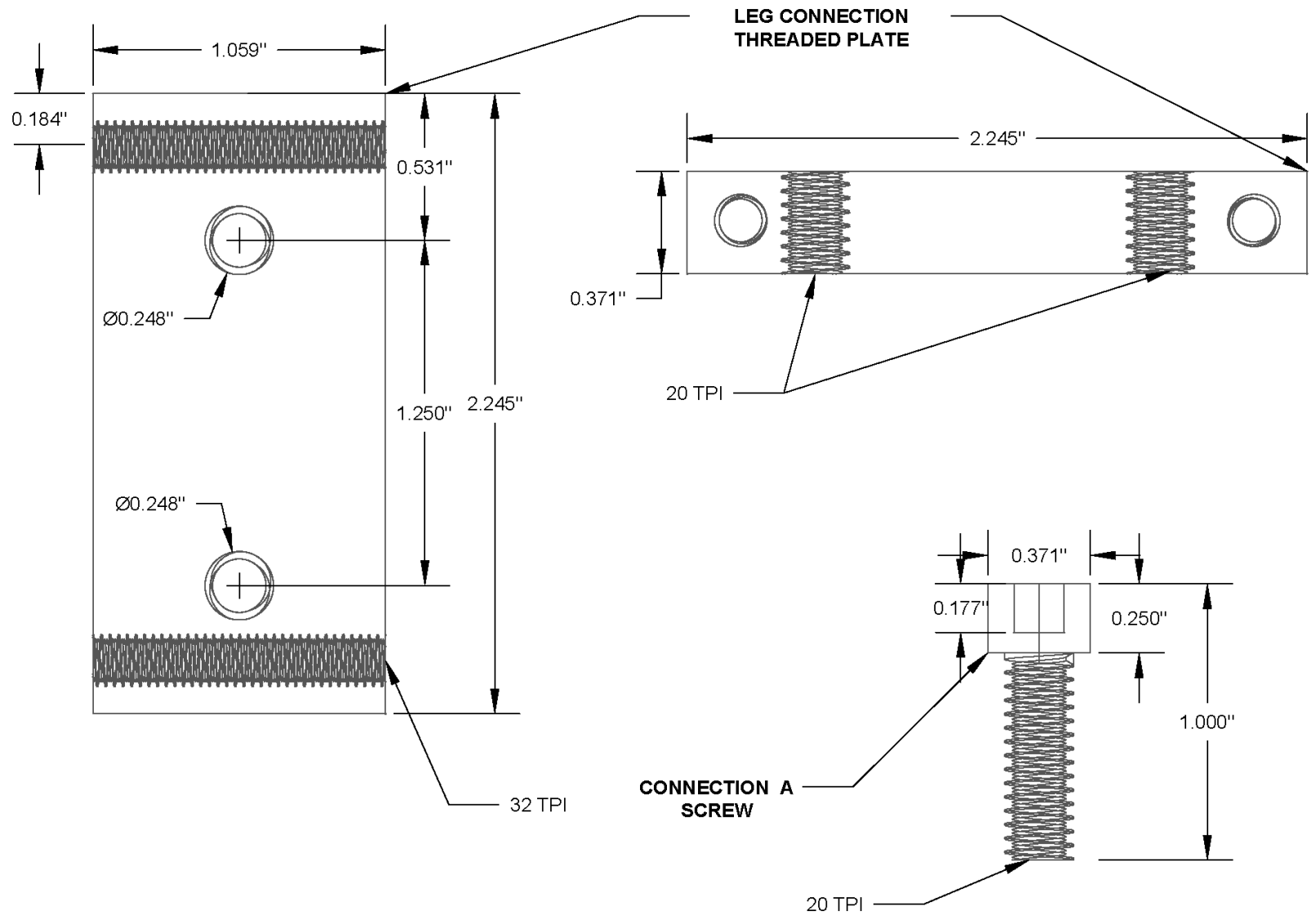

Figure 4-25. Leg connection threaded plate and Connection-A screws.

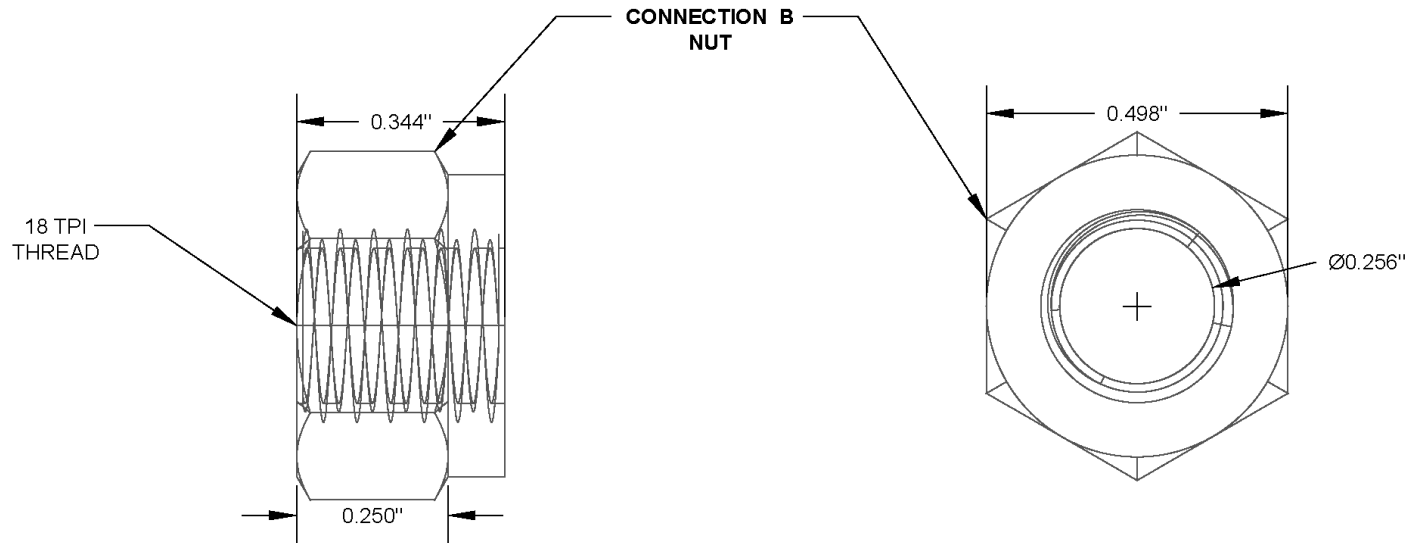
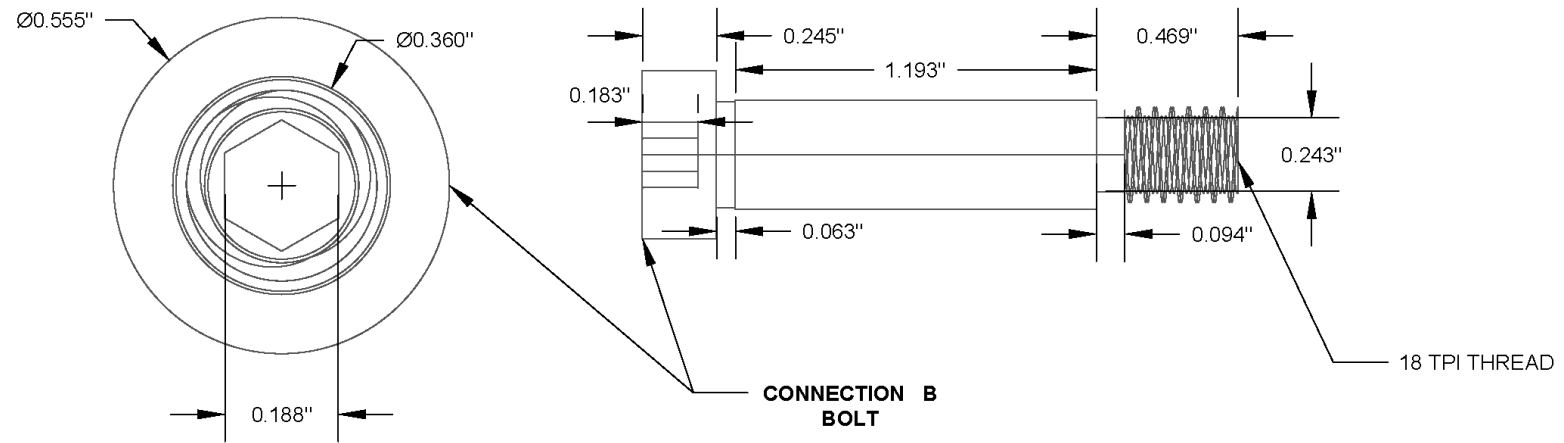

Figure 4-26. Leg Connection-B nut and bolt.

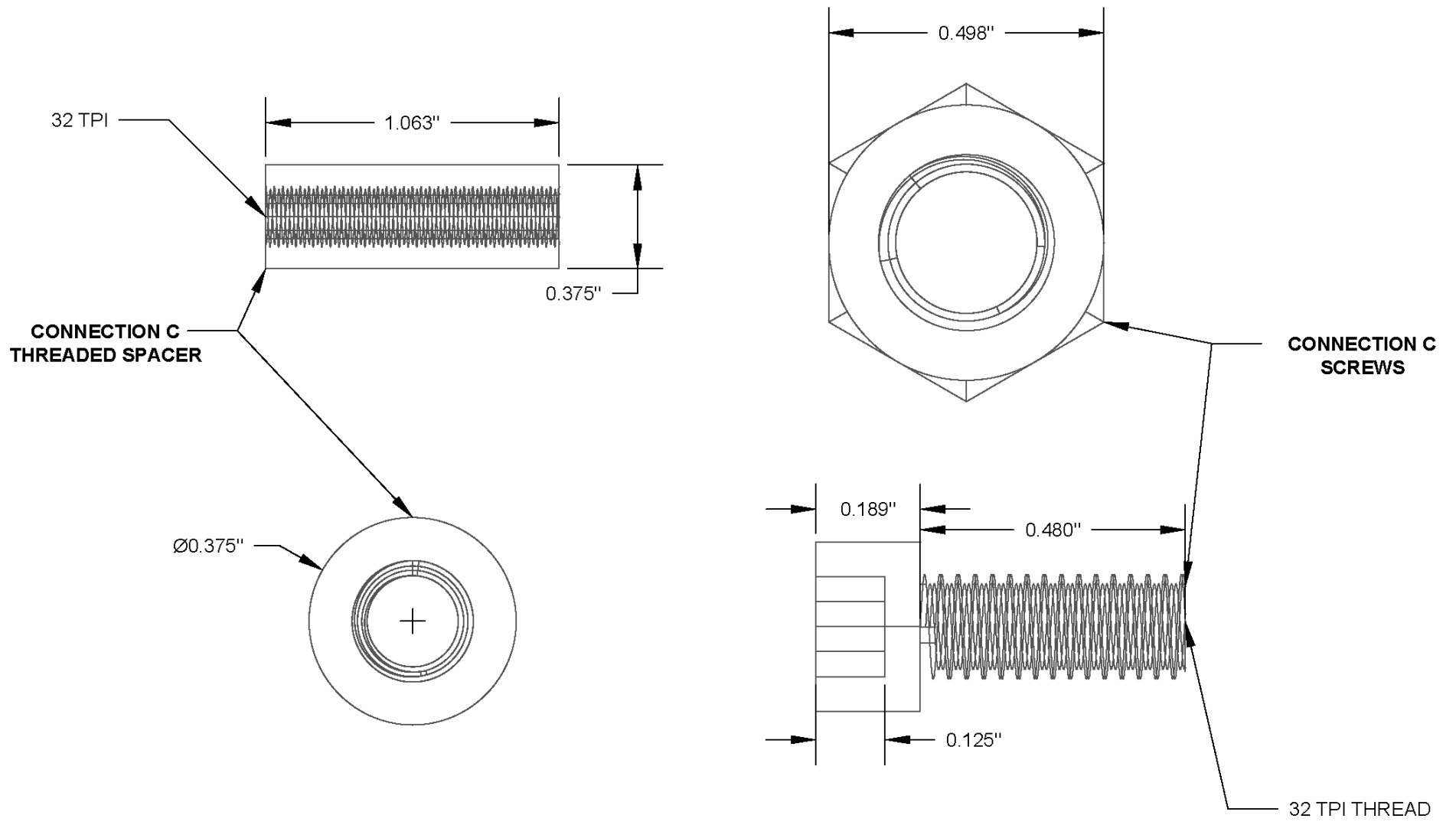

Figure 4-27. Leg Connection-C screws and threaded spacer.

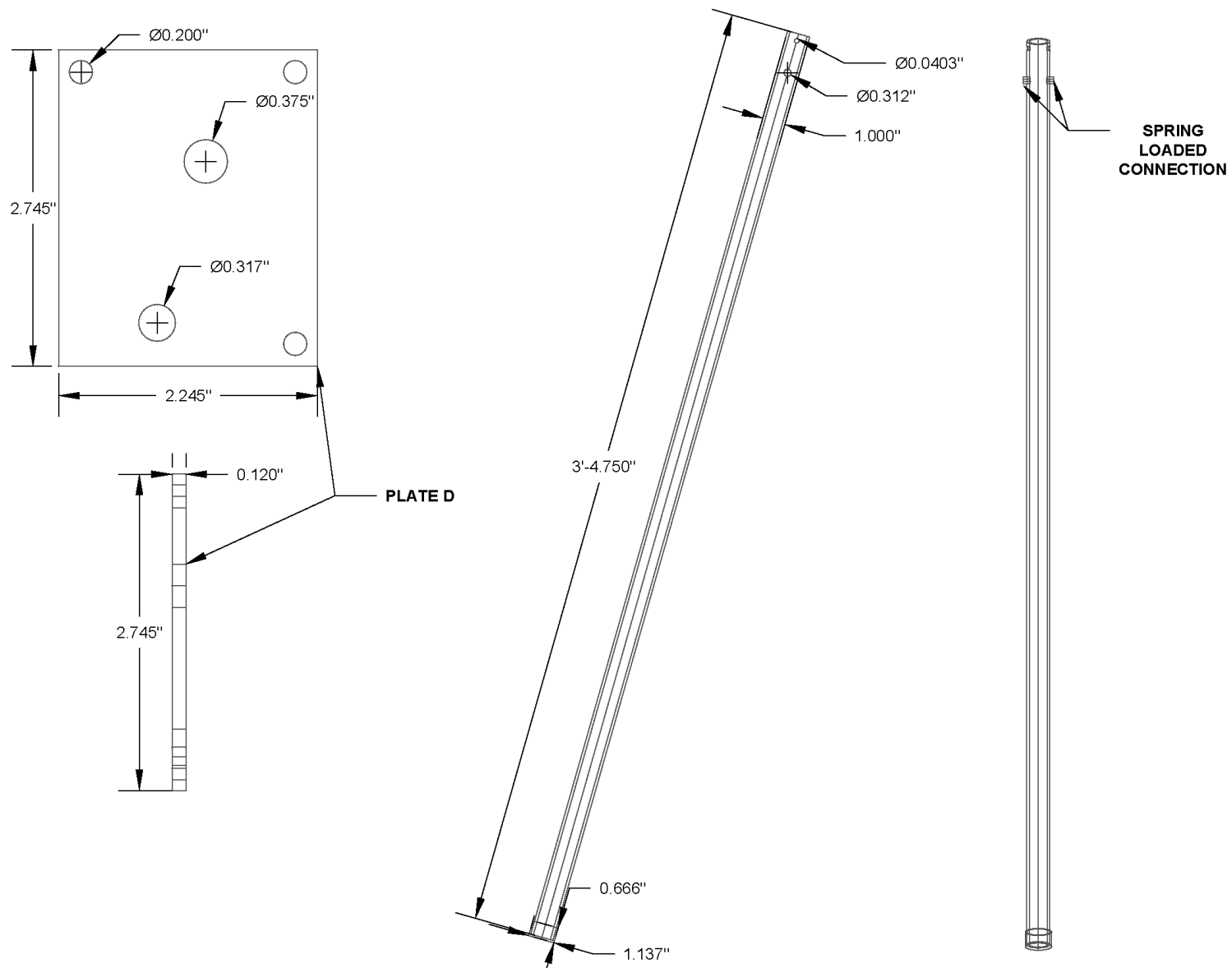

Figure 4-28. Stand legs and Connection-D plates.

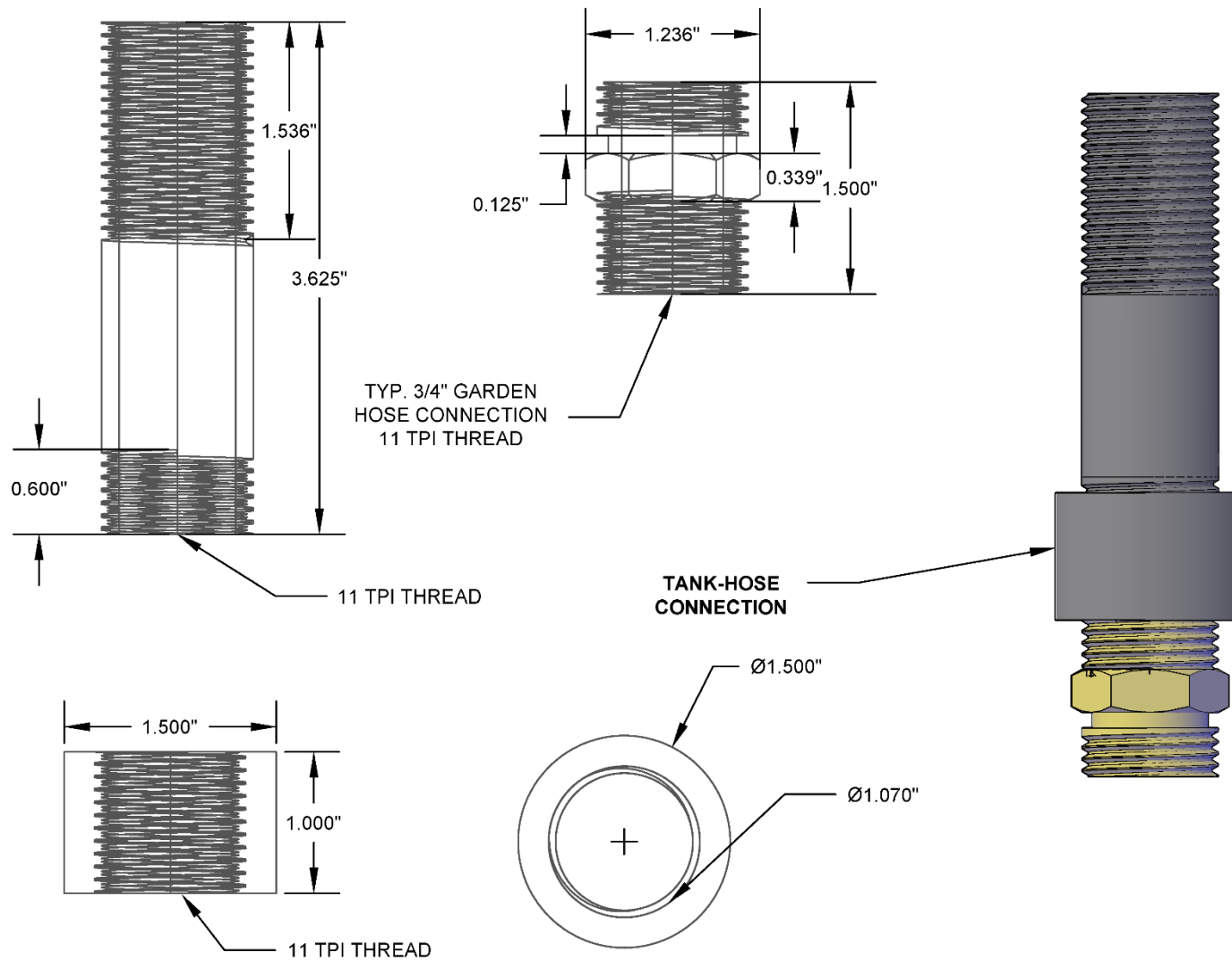

Figure 4-29. Tank-hose connection pieces.

4.13 VIP Instructional Video

An online VIP tutorial was developed as a companion to the new test method and can be found at the following URL:

<https://www.fdot.gov/materials/geotechnical/fieldoperations/index.shtm>.

The instructional video includes the following:

- Introduction,
- Probe construction,
- Attaching the probe to the drill rig and probe advancement,
- Marking AWJ rods for depth tracking,
- Attaching the falling head vessel to the drill string and introducing flow,
- The 15-minute saturation period and estimating test increments and test lengths,
- Initiating the VIP test,
- Taking VIP readings,
- Flushing the probe and closing it off after the test is complete,
- Withdrawing the probe from the ground, and
- Cleaning the probe prior to the next test location.

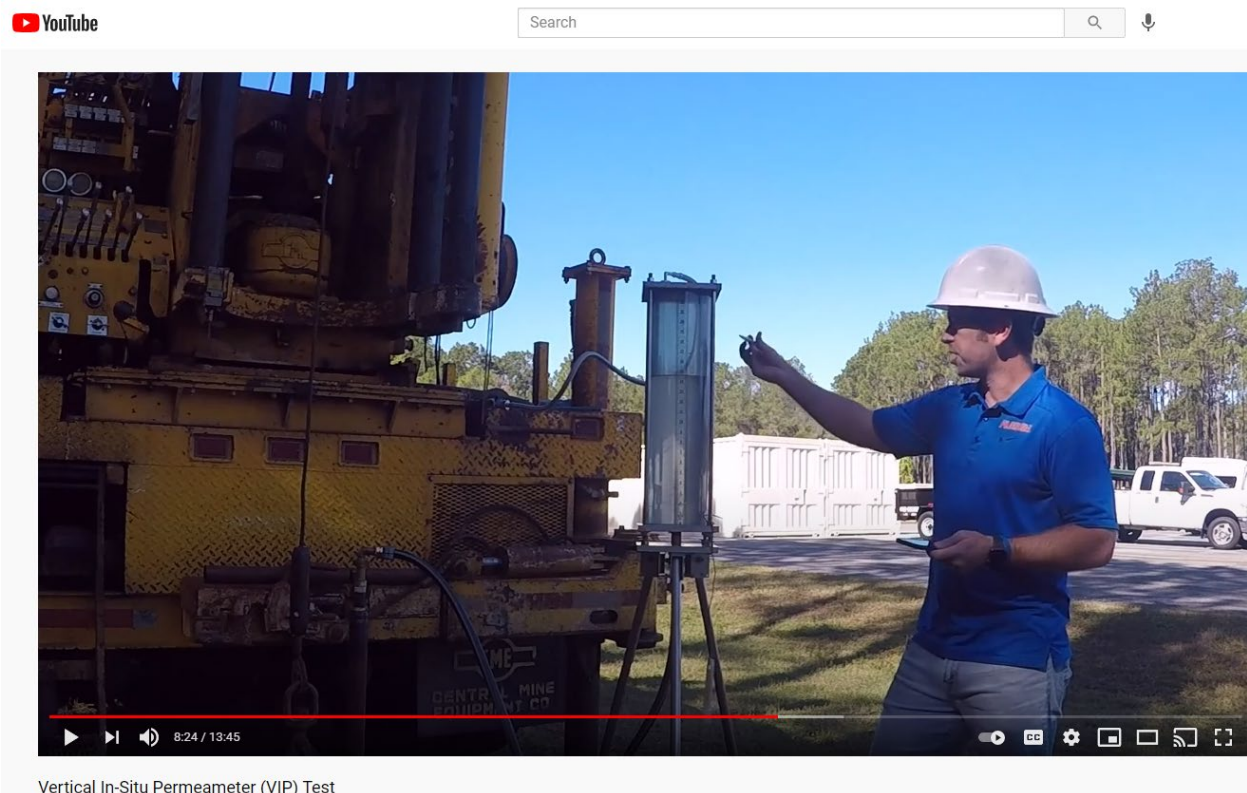

Figure 4-30. Image from VIP instructional video.

5. VIP Field Testing and Analysis

VIP testing and onsite training were provided in each FDOT district and the turnpike. The following chapter provides commentary and the results of each VIP tests completed within each FDOT district. The following results are organized by FDOT district and not the order in which the tests were completed.

Note: Due to COVID-19 restrictions, FDOT Districts 4 and 6 were combined.

5.1 District 1

District 1 testing was completed in Bartow by a district field crew who received onsite training from the UF research team and SMO field specialists. At the site, three locations were tested: C1, C2, and C3. At each test location, two VIP locations were tested at three different depths. Historical data indicated loose sand tailings and phosphatic waste clays were present at the site and macro-core samples recently collected at the site indicated the soil types present were SP, SC, and SP-SC. However, SPT testing, sieve analysis, and soil classifications were not completed within proximity to each test location, therefore, direct comparisons could not be made.

5.1.1 Location C1

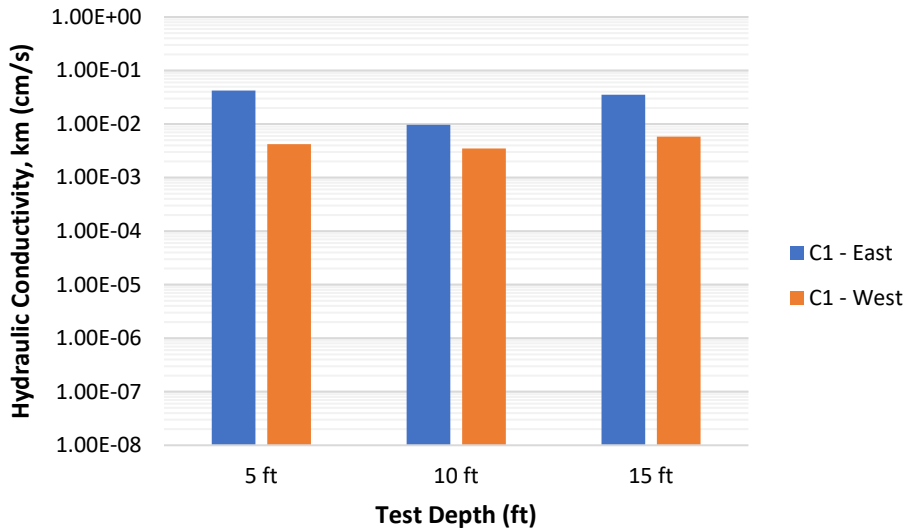

Figure 5-1. Bartow Location C1 results by depth.

5.1.2 Location C2

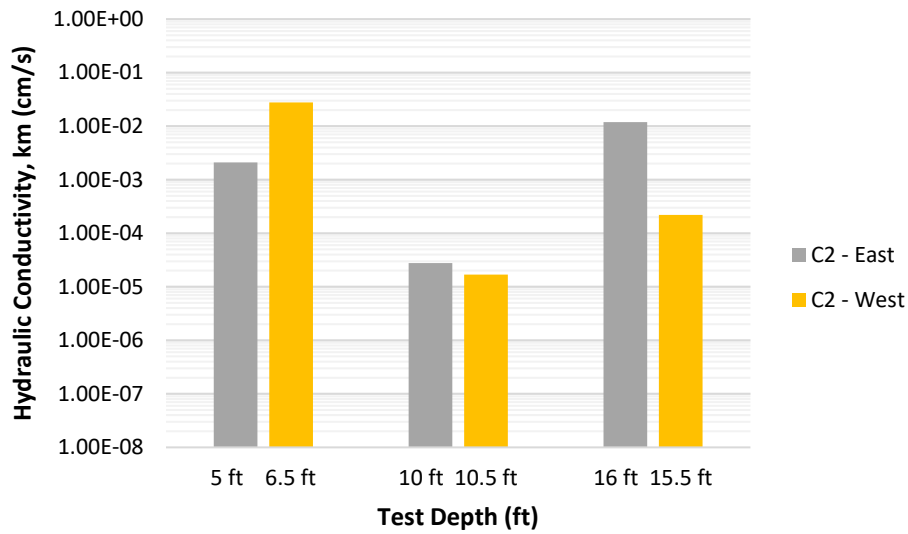

Figure 5-2. Bartow Location C2 results by depth.

5.1.3 Location C3

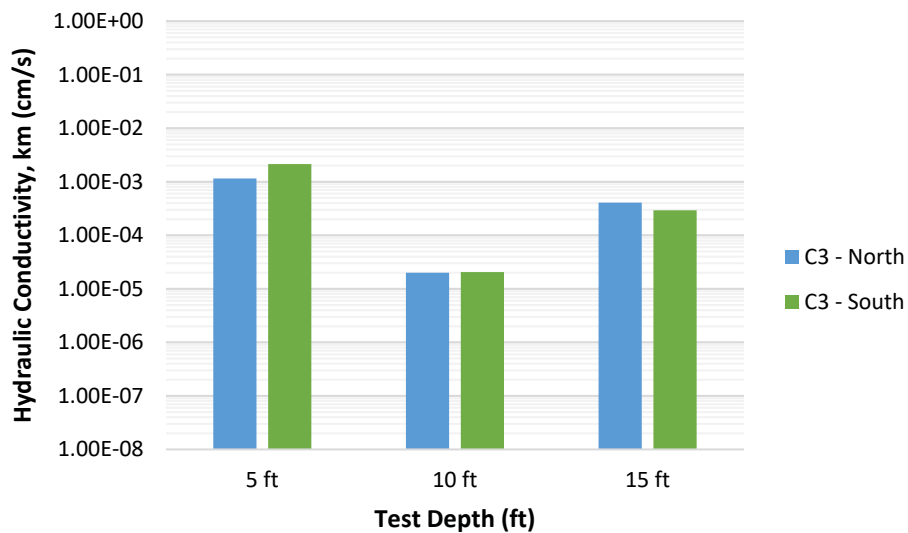

Figure 5-3. Bartow Location C3 results by depth.

5.1.4 District 1 Summary

The summary of VIP test results is provided in Table 5-1 and Figure 5-4. The summary of statistics for District 1 is provided in Table 5-2. Eighteen VIP tests were completed District 1, all of which were completed in Bartow. The permeability in District 1 ranged from $k_m = 1.69 \times 10^{-5}$ to 4.23×10^{-2} cm/s. The mean permeability was 8.17×10^{-3} cm/s and the median permeability was

2.13×10^{-3} cm/s. The coefficient of variability was $CV = 1.61$. At the Bartow site Locations C2 and C3 showed similar trends with depth with C3 measuring the lowest permeability on average. Location C1 indicated higher and similar permeabilities at each location and depth.

Table 5-1. District 1 summary of VIP test results.

Site	Location	Depth (ft)	SPT N	Permeability		Soil Type	
				k_m (cm/s)	k_m (ft/day)	AASHTO	USCS
Bartow	C1T1E	5	N/A	4.23×10^{-2}	104.95	N/A	N/A
	C1T2E	10	N/A	9.67×10^{-3}	23.99	N/A	N/A
	C1T3E	15	N/A	3.54×10^{-2}	87.82	N/A	N/A
	C1T1W	5	N/A	4.23×10^{-3}	10.48	N/A	N/A
	C1T2W	10	N/A	3.50×10^{-3}	8.68	N/A	N/A
	C1T3W	15	N/A	5.81×10^{-3}	14.41	N/A	N/A
	C2T1E	5	N/A	2.11×10^{-3}	5.23	N/A	N/A
	C2T2E	10	N/A	2.78×10^{-5}	0.07	N/A	N/A
	C2T3E	15	N/A	1.19×10^{-2}	29.59	N/A	N/A
	C2T1W	5	N/A	2.79×10^{-2}	69.08	N/A	N/A
	C2T2W	10	N/A	1.69×10^{-5}	0.04	N/A	N/A
	C2T3W	15	N/A	2.20×10^{-4}	0.55	N/A	N/A
	C3T1N	5	N/A	1.15×10^{-3}	2.86	N/A	N/A
	C3T2N	10	N/A	2.00×10^{-5}	0.05	N/A	N/A
	C3T3N	15	N/A	4.07×10^{-4}	1.01	N/A	N/A
	C3T1S	5	N/A	2.15×10^{-3}	5.33	N/A	N/A
	C3T2S	10	N/A	2.06×10^{-5}	0.05	N/A	N/A
	C3T3S	15	N/A	2.93×10^{-4}	0.73	N/A	N/A

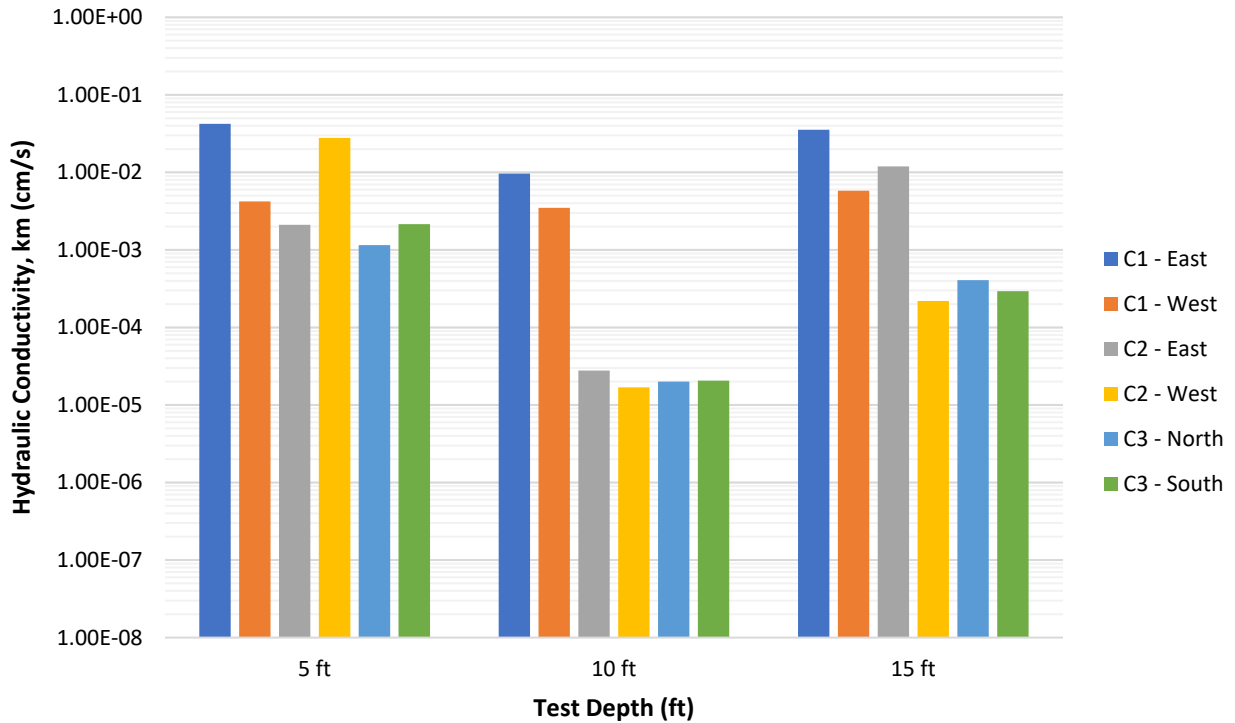

Figure 5-4. District 1 summary of results by depth.

Table 5-2. District 1 VIP test summary of statistics.

Statistics	k_m (cm/s)
Mean	8.17×10^{-3}
Median	2.13×10^{-3}
Std. Dev.	1.31×10^{-2}
CV	1.61
Maximum	4.23×10^{-2}
Minimum	1.69×10^{-5}
Count	18

5.2 District 2

District 2 testing was completed in Trenton, Newberry, and County Road 349 near Lake City. The SMO field specialists conducted testing at the Trenton and CR 349 sites. District 2 field specialists received training at the Trenton site and performed testing at the Newberry site. Onsite training was provided to District 2 consultants at the CR349 site.

5.2.1 Trenton

At the Trenton site, two locations were tested. At Location 1, three VIP locations were tested. At Location 2, one VIP location was tested. SPT testing, sieve analysis, and soil classifications were completed within proximity to each test location at the Trenton site and are provided for reference of soil type and soil density. VIP push tests (Figure 3-8) to quantify soil density were completed within proximity to Location 2. At each test location, cased constant head (CCH) borehole tests were also conducted by the SMO field crew for comparison with the VIP results.

5.2.1.1 Location 1

The soils present at Location 1 were A-3 and A-2-4. SPT blow counts ranged from three to eight. The VIP and CCH results both indicated a decrease in permeability at 15 feet of depth. This is in agreement with the soil classifications and SPT blow counts.

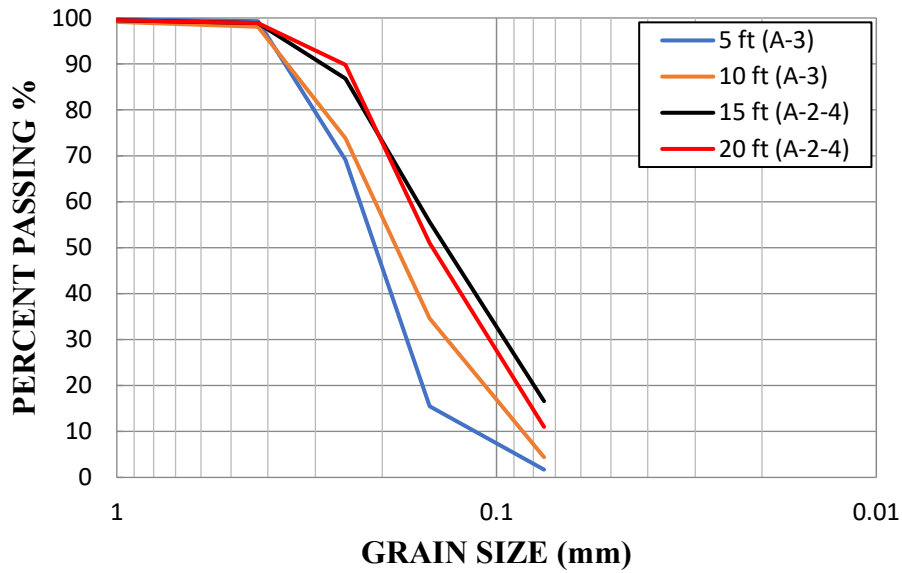

Figure 5-5. Trenton Location 1 sieve analyses.

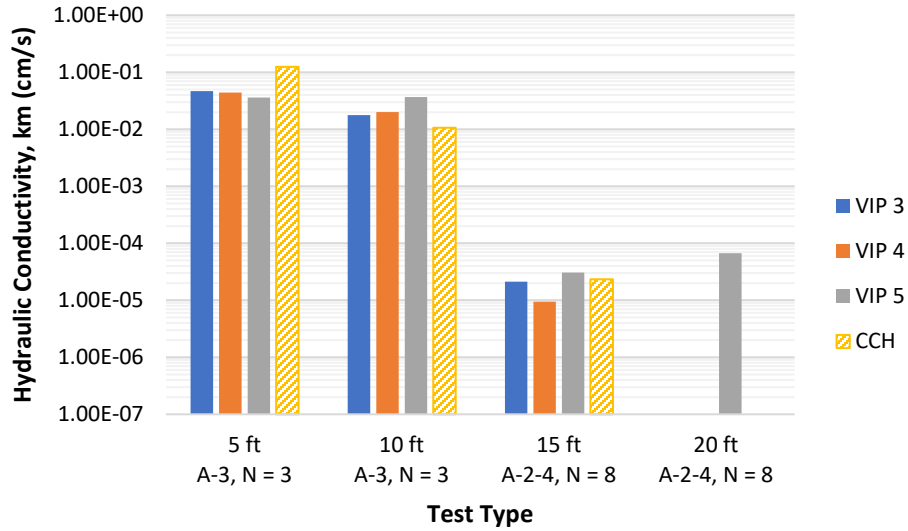

Figure 5-6. Trenton Location 1 VIP and CCH results.

5.2.1.2 Location 2

At Location 2, the soil type was the same at each test depth. However, SPT blow counts and VIP probe push tests (Figure 3-8) both indicated increasing soil density at the depth which the VIP and CCH results both indicated a decrease in permeability.

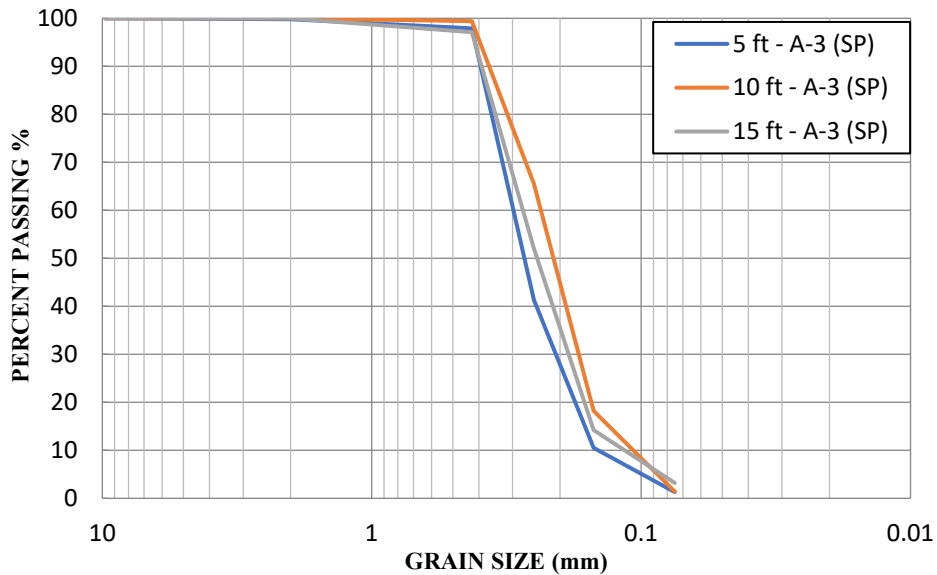

Figure 5-7. Trenton Location 2 sieve analyses.

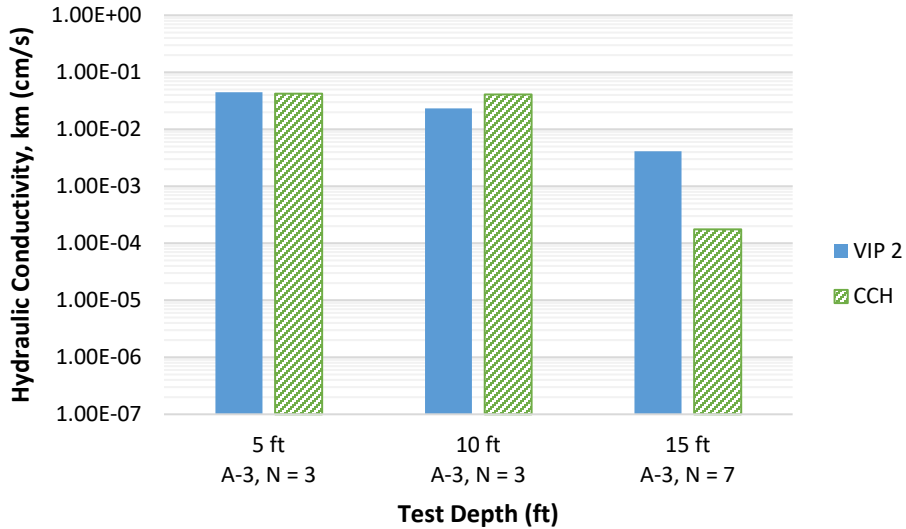

Figure 5-8. Trenton Location 1 VIP and CCH results.

5.2.2 Newberry

At the Newberry site, VIP testing was performed at a potential retention pond location. Consequently, VIP tests were conducted at the same elevation at three locations spread across the site. From Figure 5-9, it can be observed that similar hydraulic conductivity was measured at each location with a slight increase in k_m moving East to West (P8 to P4). The results indicate that the elevation tested has a permeability with poor drainage characteristics.

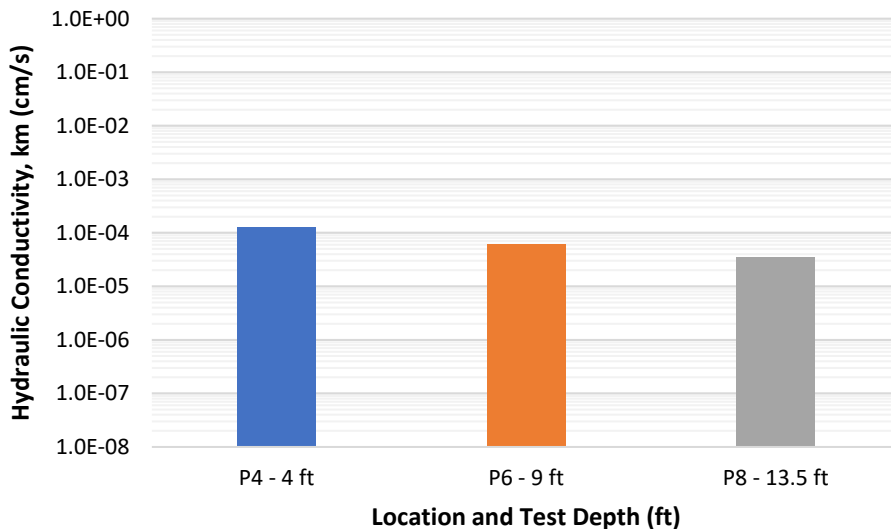

Figure 5-9. Newberry VIP results.

5.2.3 County Road 349

The County Road 349 site was used to provide a VIP demonstration and onsite training to District 2 consultants. At the site, one location was tested at three different depths. Minimal VIP

testing was completed due to the low permeability present. The VIP measurements at depths 10 and 15 feet were two of the lowest permeabilities measured throughout the research effort and provided the lowest permeability measured by any VIP probe at the time. This occurred at a depth of 15 feet where the soil recovered and tested in the laboratory was identified as an A-7-6 (CH) clay soil with high plasticity in a dense state as the SPT blow counts were $N = 25$. Images of the soil samples collected are provided in Figure 5-10, sieve analyses are provided in Figure 5-11, and the VIP results are provided in Figure 5-12.

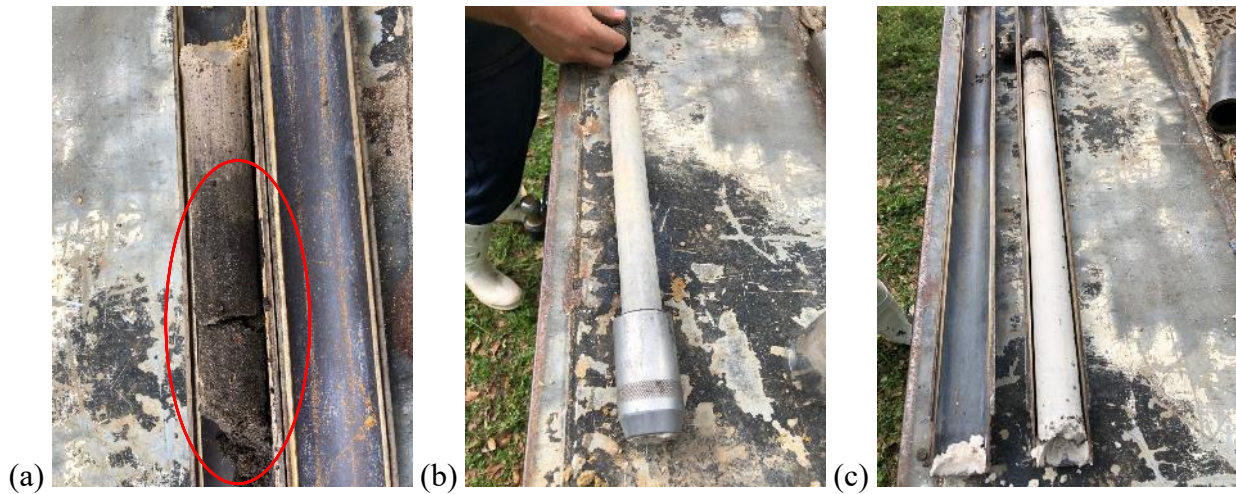

Figure 5-10. SPT samples recovered at depths (a) 5 feet, (b) 10 feet, and (c) 15 feet.

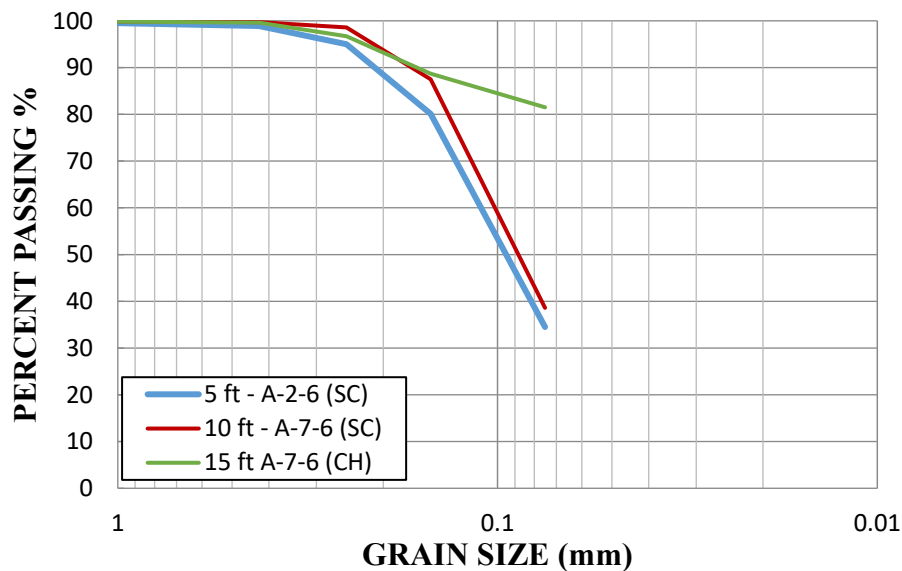

Figure 5-11. County Road 349 sieve analyses.

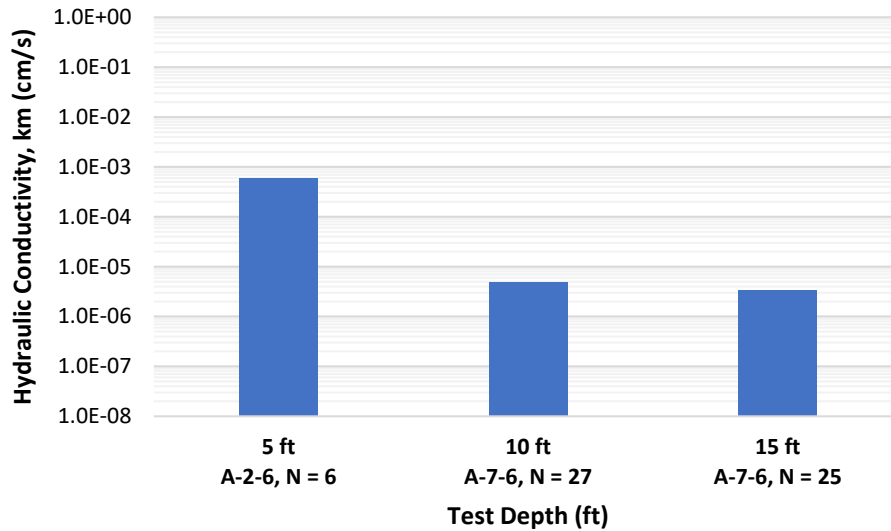

Figure 5-12. County Road 349 VIP results.

5.2.4 District 2 Summary

The District 2 summary of VIP test results are provided in Table 5-3 and Figure 5-12. The summary of statistics for District 2 is provided in Table 5-4. Nineteen VIP tests were completed District 2, with 13 tests completed in Trenton, three tests in Newberry, and three tests at CR349. The permeabilities in District 2 ranged from $k_m = 3.45 \times 10^{-6}$ to 4.68×10^{-2} cm/s. The mean permeability was 1.45×10^{-2} cm/s and the median permeability was 1.45×10^{-2} cm/s. The coefficient of variability was $CV = 1.27$.

Table 5-3. District 2 summary of VIP results.

Site	Location	Depth (ft)	SPT N	Permeability		Soil Type	
				k_m (cm/s)	k_m (ft/day)	AASHTO	USCS
Trenton	H2T1	5	3	4.48×10^{-2}	111.09	A-3	SP
	H2T2	10	3	2.32×10^{-2}	57.65	A-3	SP
	H2T3	15	7	4.13×10^{-3}	10.23	A-3	SP
	H3T1	5	3	4.68×10^{-2}	116.01	A-3	SP
	H3T2	10	3	1.77×10^{-2}	43.91	A-3	SP
	H3T3	15	8	2.12×10^{-5}	0.05	A-2-4	SM
	H4T1	5	3	4.41×10^{-2}	109.36	A-3	SP
	H4T2	10	3	2.01×10^{-2}	49.83	A-3	SP
	H4T3	15	8	9.48×10^{-6}	0.02	A-2-4	SM
	H5T1	5	3	3.62×10^{-2}	89.86	A-3	SP
	H5T2	10	3	3.69×10^{-2}	91.51	A-3	SP
	H5T3	15	8	3.08×10^{-5}	0.08	A-2-4	SM
	H5T4	20	8	6.73×10^{-5}	0.17	A-2-4	SM
	CR 349	CR1T1	5	6	5.87×10^{-4}	1.46	A-2-6
CR1T2		10	27	4.99×10^{-6}	0.01	A-7-6	SC
CR1T3		15	25	3.45×10^{-6}	0.01	A-7-6	CH
Newberry	P4	4	N/A	1.28×10^{-4}	0.32	N/A	N/A
	P6	9	N/A	6.04×10^{-5}	0.15	N/A	N/A
	P8	13.5	N/A	3.46×10^{-5}	0.09	N/A	N/A

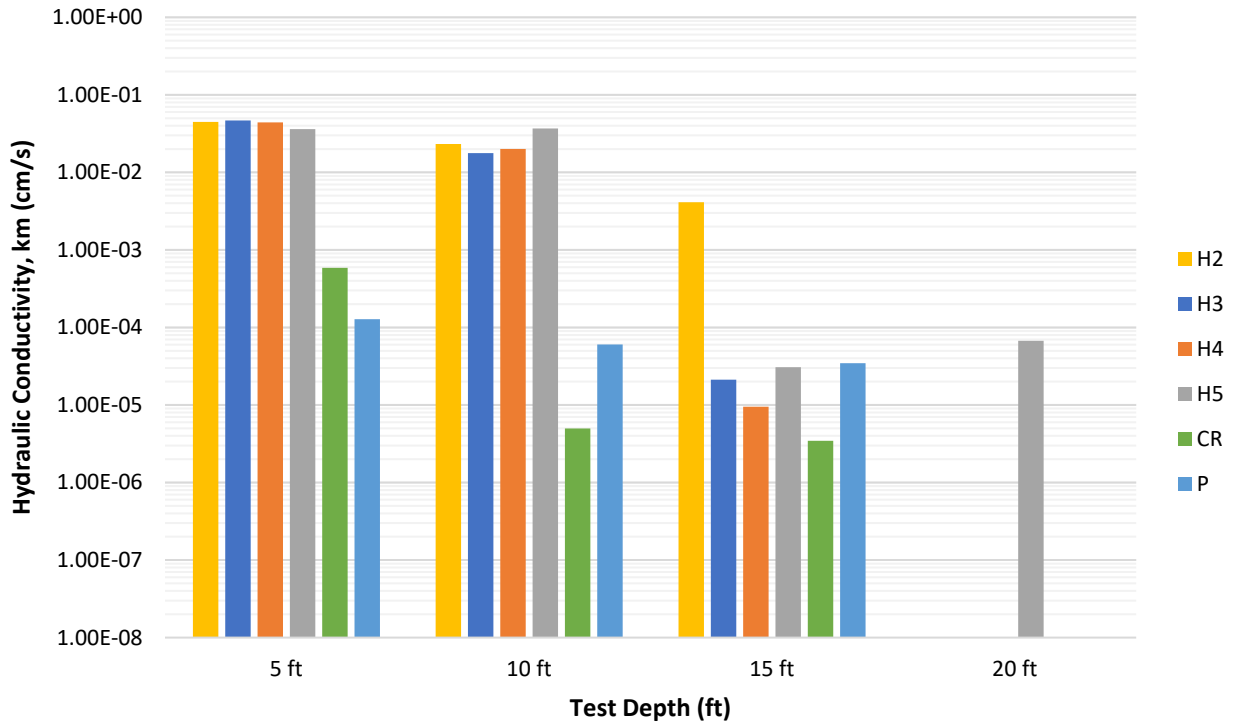

Figure 5-13. District 2 VIP results.

Table 5-4. District 2 summary of statistics.

Statistics	k_m (cm/s)
Mean	1.45×10^{-2}
Median	5.87×10^{-4}
Std Dev	1.84×10^{-2}
CV	1.27
Maximum	4.68×10^{-2}
Minimum	3.45×10^{-6}
Count	19

5.3 District 3

District 3 testing was completed in Marianna and Cottondale. District 3 field specialists received training at the Marianna site and performed testing at both sites.

5.3.1 Marianna

At the Marianna site, two locations were tested each at three different depths. The permeability measured was relatively low at each location and depth. The soil transitioned from an A-2-7 clayey sand at five feet of depth to an A-7-6 clayey sand at depths of 10 and 15 feet. The SPT blow counts were similar at each depth and similar range of permeabilities were measured at

each depth. Images of the soil samples collected are provided in Figure 5-14, sieve analyses are provided in Figure 5-15, and the VIP results are provided in Figure 5-16.

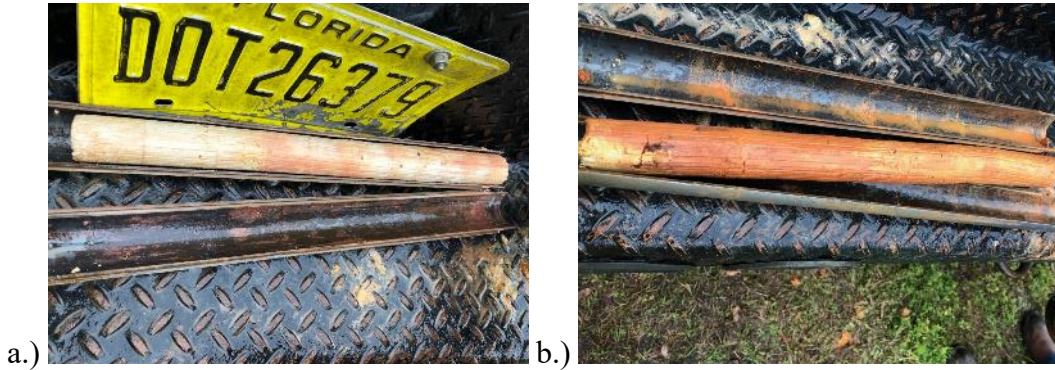

Figure 5-14. SPT samples collected at a.) 10 feet and b.) 15 feet.

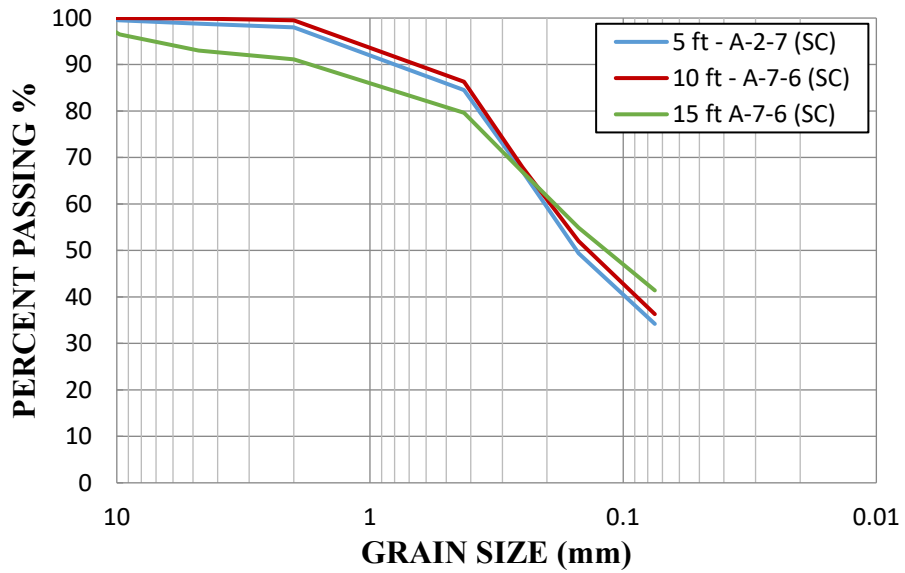

Figure 5-15. Marianna sieve analyses.

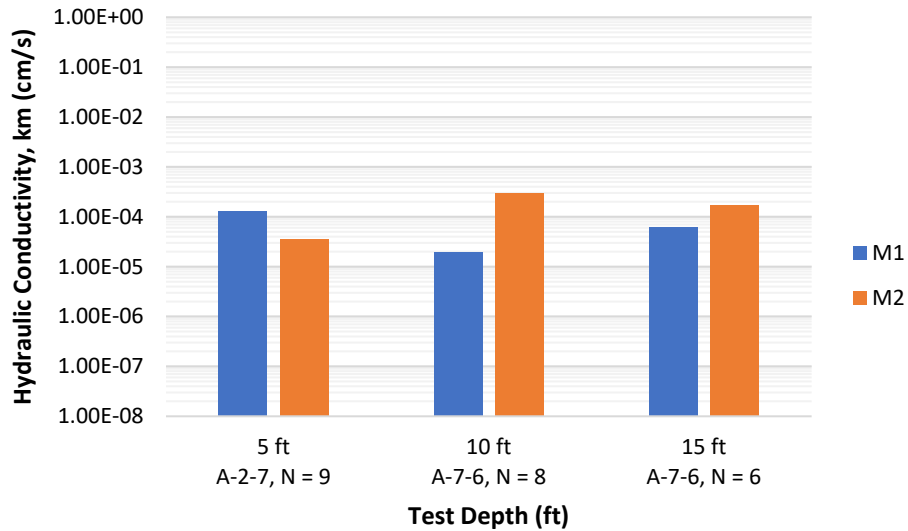

Figure 5-16. Marianna VIP Results.

5.3.2 Cottondale

At the Cottondale site, three locations were tested each at three different depths (10, 15, and 20 feet). The permeability measured was variable at each location and depth. However, the average permeability measured at each depth was nearly identical across the site (5.28×10^{-4} cm/s @ 10-ft, 3.50×10^{-4} cm/s @ 15-ft, 3.64×10^{-4} cm/s @ 20-ft). Location C-3 had the lowest average permeability. Images of the soil samples collected are provided in Figure 5-17, sieve analyses are provided in Figure 5-18, and the VIP results are provided in Figure 5-19.



Figure 5-17. Soil samples collected at the Cottondale site.

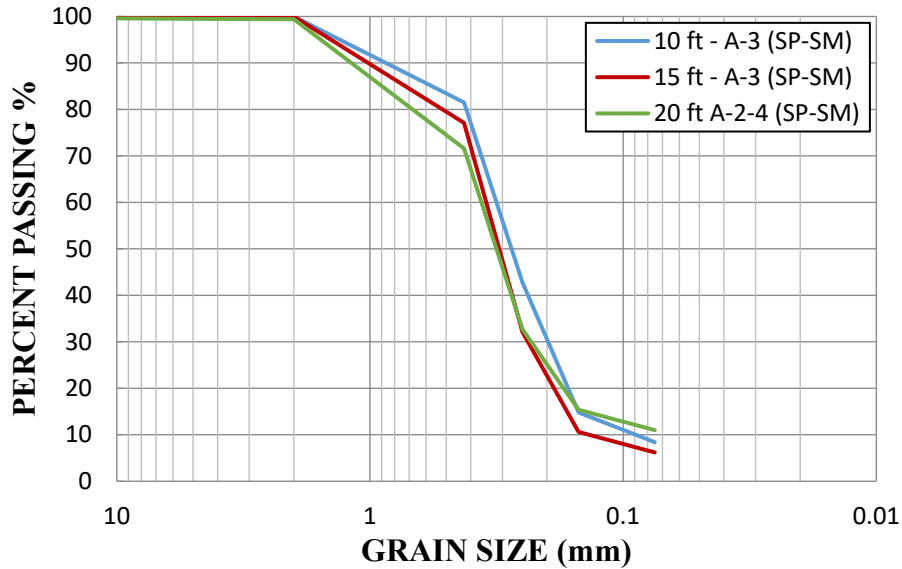

Figure 5-18. Cottondale sieve analyses.

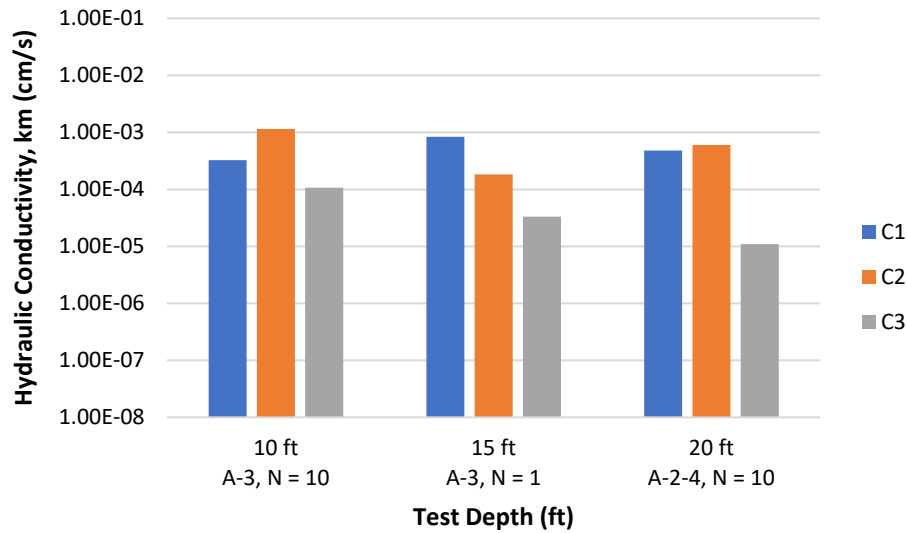

Figure 5-19. Cottondale VIP Results.

5.3.3 District 3 Summary

The District 3 summary of VIP test results are provided in Table 5-5 and Figure 5-20. The summary of statistics for District 3 is provided in Table 5-6. Fifteen VIP tests were completed in District 3, with six tests completed in Marianna and nine tests in Cottondale. The permeabilities in District 3 ranged from $k_m = 9.48 \times 10^{-6}$ to 1.15×10^{-3} cm/s which was lowest range measured in any district. The mean permeability was 2.68×10^{-4} cm/s and the median permeability was 1.07×10^{-4} cm/s, both of which were also the lowest measured in any district. The coefficient of variability was $CV = 1.31$.

Table 5-5. District 3 summary of VIP results.

Site	Location	Depth (ft)	SPT N	Permeability		Soil Type	
				km (cm/s)	km (ft/day)	AASHTO	USCS
Marianna	M1T1	5	9	1.29×10^{-4}	0.3	A-2-7	SC
	M1T2	10	8	2.12×10^{-5}	0.05	A-7-6	SC
	M1T3	15	6	9.48×10^{-6}	0.02	A-7-6	SC
	M2T1	5	9	3.60×10^{-5}	0.1	A-2-7	SC
	M2T2	10	8	3.08×10^{-5}	0.08	A-7-6	SC
	M2T3	15	6	6.73×10^{-5}	0.17	A-7-6	SC
Cottondale	C1T1	10	10	3.25×10^{-4}	0.80	A-3	SP-SM
	C1T2	15	1	8.34×10^{-4}	2.07	A-3	SP-SM
	C1T3	20	11	4.78×10^{-4}	1.19	A-2-4	SP-SM
	C2T1	10	10	1.15×10^{-3}	2.86	A-3	SP-SM
	C2T2	15	1	1.84×10^{-4}	0.46	A-3	SP-SM
	C2T3	20	11	6.02×10^{-4}	1.49	A-2-4	SP-SM
	C3T1	10	10	1.07×10^{-4}	0.26	A-3	SP-SM
	C3T2	15	1	3.31×10^{-5}	0.08	A-3	SP-SM
	C3T3	20	11	1.09×10^{-5}	0.03	A-2-4	SP-SM

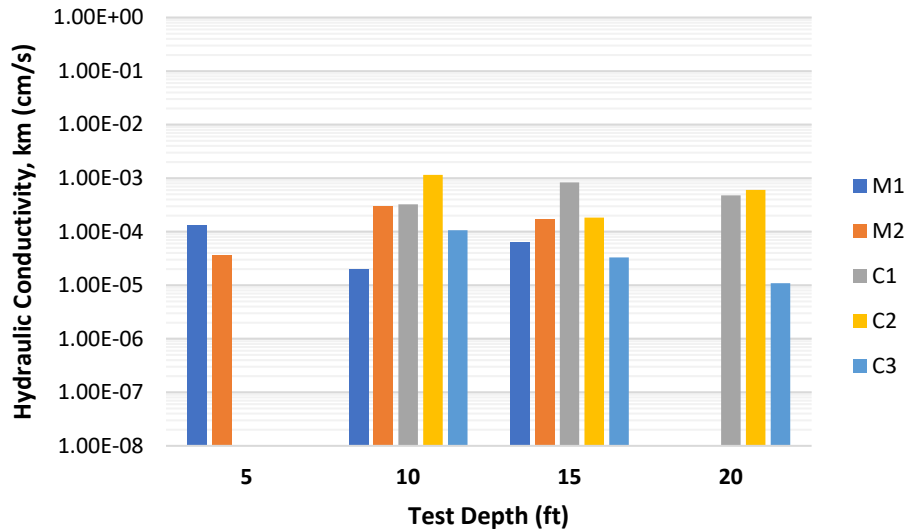

Figure 5-20. District 3 VIP summary of results.

Table 5-6. District 3 VIP summary of statistics.

Statistics	k_m (cm/s)
Mean	2.68×10^{-4}
Median	1.07×10^{-4}
Std Dev	3.50×10^{-4}
CV	1.31
Maximum	1.15×10^{-3}
Minimum	9.48×10^{-6}
Count	15

5.4 District 4 & Turnpike

District 4 VIP testing was completed at the District 4 Operations Center located in West Palm Beach. At the site, two locations were tested with most of the testing taking place at Location 1 due to consistent encounters with shell and limestone fragments at Location 2. The district’s consultant drill crew received onsite training and completed all of the VIP testing at the site. District 4, District 6, and turnpike consultants also received onsite training. The test depths ranged from five to twenty feet with a large range of SPT blow counts recorded. All the soils encountered were classified as A-3. This provided an opportunity to investigate the influence of soil density on soil permeability.

Note: District 4, District 6, and Turnpike engineers and consultants received VIP training, however, VIP testing was only completed in District 4 due to COVID-19 restrictions in District 6.

5.4.1 Location 1

At Location 1, 17 VIP tests were completed at five different locations with depths ranging from five to twenty feet. The permeabilities measured were consistent with changes in SPT blow counts (indicative of soil density) at each location. Sieve analyses are provided in Figure 5-21, and the VIP results are provided in Figure 5-22.

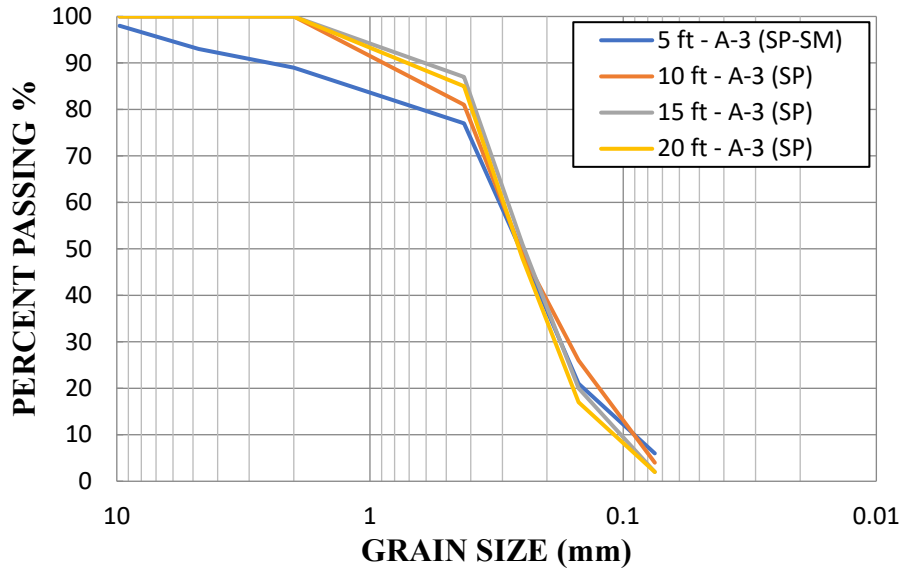

Figure 5-21. District 4 Location 1 sieve analyses.

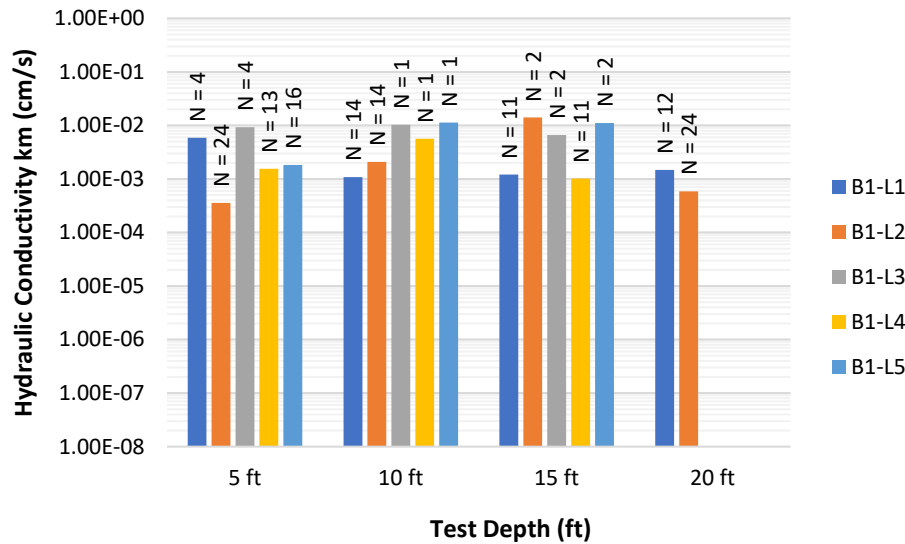

Figure 5-22. District 4 Location 1 VIP results.

5.4.2 Location 2

At Location 2, only five VIP tests were completed. Location 2 was tested first at the site where shell and limestone fragments were consistently encountered, and a large amount axial force was required to advance the probe to the first test depth. SPT hammering was also used. It was decided to hand auger the first three to four feet and then advance the probe because the drill rig was close to lifting off the ground from the large axial force applied to the probe for advancement. When advancing the VIP probe down the open hole, a piece of electric tape was used to ensure the probe remained in its closed position until direct push could be used again for advancement. This can be observed in Figure 5-23. This method was then applied at each of the

subsequent test locations at the District 4 site and is recommended for future open-hole advancements. For example, if pre-drilling is required to advance the probe, predrill the hole to a minimum of one foot above the test depth, place electric tape on the VIP probe as indicated in Figure 5-23, advance the probe down the open hole, direct push the final one foot or more to the test depth, and then initiate the VIP test. Location 2 sieve analyses are provided in Figure 5-24, and the VIP results are provided in Figure 5-25.



Figure 5-23. VIP probe with electric tape to ensure closed position for open-hole advancement.

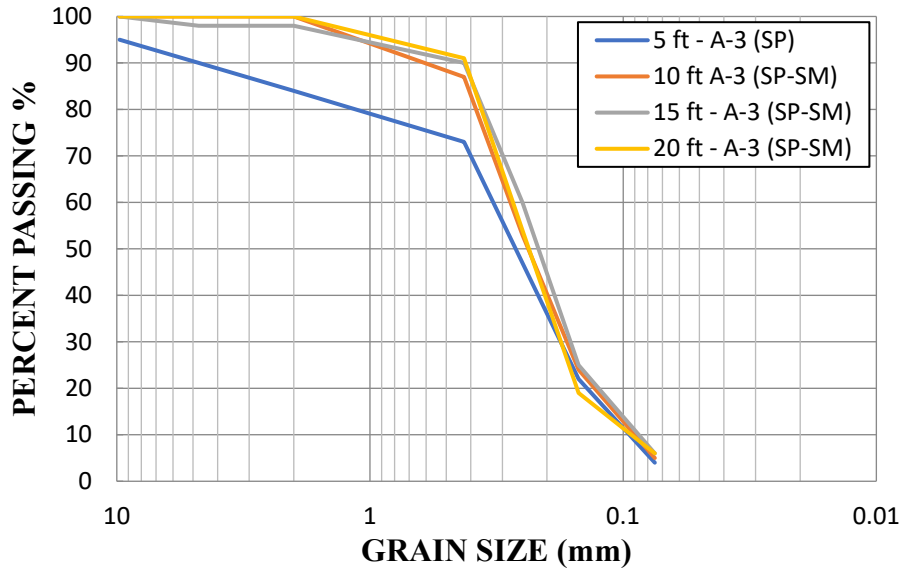

Figure 5-24. District 4 Location 2 sieve analyses.

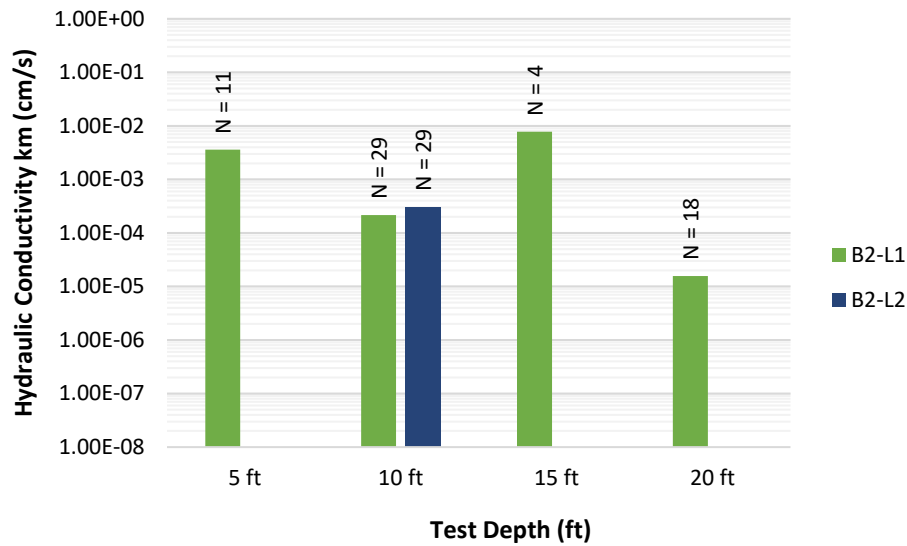

Figure 5-25. District 4 Location 2 VIP results.

Observed in Figure 5-25, the VIP result at a depth of 20 feet appeared low for the soil type and SPT blow counts measured at this depth based on the other VIP and SPT measurements recorded at the location. It was discovered that this was a false reading, and a result of too much copper grease being applied at the AWJ rod threaded connections which was transmitted through the drill string and out of the probe tip (Figure 5-26). Researchers suspect the grease permeated into the soil and caused the false reading. This VIP measurement was removed from further consideration.



Figure 5-26. Grease transmitted through the drill string and out of the probe.

5.4.3 District 4 Summary

The District 4 summary of VIP test results are provided in Table 5-7 and Figure 5-27. The summary of statistics for District 4 is provided in Table 5-8. 22 VIP tests were completed in District 4, with one test removed from further analysis due to a false reading as discussed. The permeabilities in District 4 ranged from $k_m = 2.16 \times 10^{-4}$ to 1.41×10^{-2} cm/s which was highest range measured in any district. The mean permeability was 1.41×10^{-2} cm/s and the median permeability was 2.08×10^{-3} cm/s. The coefficient of variability was $CV = 0.95$ which was the lowest degree of variability measured in any district. Interestingly, the changes in permeability at the site were dictated by the density of the soil, indicated by SPT blow counts, as the soil type was the same at all depths and locations. This can be observed in Figure 5-29 where permeability is plotted as a function of SPT blow counts.

Note: Consultant open borehole falling head tests were completed for comparison with the VIP results. However, the recorded permeability measurements ranged from 1.5×10^{-4} cm/s to 7.56×10^{-6} cm/s which appear too low for an A-3 soil with a maximum fines content of 6% at any location and depth. These measurements are typically associated with silty or clayey soils. This illustrates a common issue with traditional borehole testing and signifies the benefits of an alternative field test method such as the VIP test.

Table 5-7. District 4 summary of VIP results.

Site	Location	Depth (ft)	SPT N	Permeability		Soil Type	
				km (cm/s)	km (ft/day)	AASHTO	USCS
W. Palm	B1-L1-T1	5	4	5.88×10^{-3}	14.58	A-3	SP-SM
	B1-L1-T2	10	14	1.08×10^{-3}	2.69	A-3	SP
	B1-L1-T3	15	11	1.21×10^{-3}	2.99	A-3	SP
	B1-L1-T4	20	12	1.47×10^{-3}	3.66	A-3	SP
	B1-L2-T1	5	24	3.58×10^{-4}	0.89	A-3	SP-SM
	B1-L2-T2	10	1	2.08×10^{-3}	5.16	A-3	SP
	B1-L2-T3	15	2	1.41×10^{-2}	34.97	A-3	SP
	B1-L2-T4	20	24	5.87×10^{-4}	1.46	A-3	SP
	B1-L3-T1	5	4	9.25×10^{-3}	22.94	A-3	SP-SM
	B1-L3-T2	10	1	1.03×10^{-2}	25.49	A-3	SP
	B1-L3-T3	15	2	6.63×10^{-3}	16.46	A-3	SP
	B1-L4-T1	5	13	1.55×10^{-3}	3.84	A-3	SP-SM
	B1-L4-T2	10	1	5.65×10^{-3}	14.02	A-3	SP
	B1-L4-T3	15	11	1.02×10^{-3}	2.53	A-3	SP
	B1-L5-T1	5	16	1.83×10^{-3}	4.53	A-3	SP-SM
	B1-L5-T2	10	1	1.13×10^{-2}	28.13	A-3	SP
	B1-L5-T3	15	2	1.11×10^{-2}	27.60	A-3	SP
	B2-L1-T1	5	11	3.62×10^{-3}	8.97	A-3	SP
	B2-L1-T2	10	29	2.16×10^{-4}	0.54	A-3	SP-SM
	B2-L1-T3	16	4	7.80×10^{-3}	19.36	A-3	SP-SM
	B2-L2-T1	10	29	3.02×10^{-4}	0.75	A-3	SP-SM

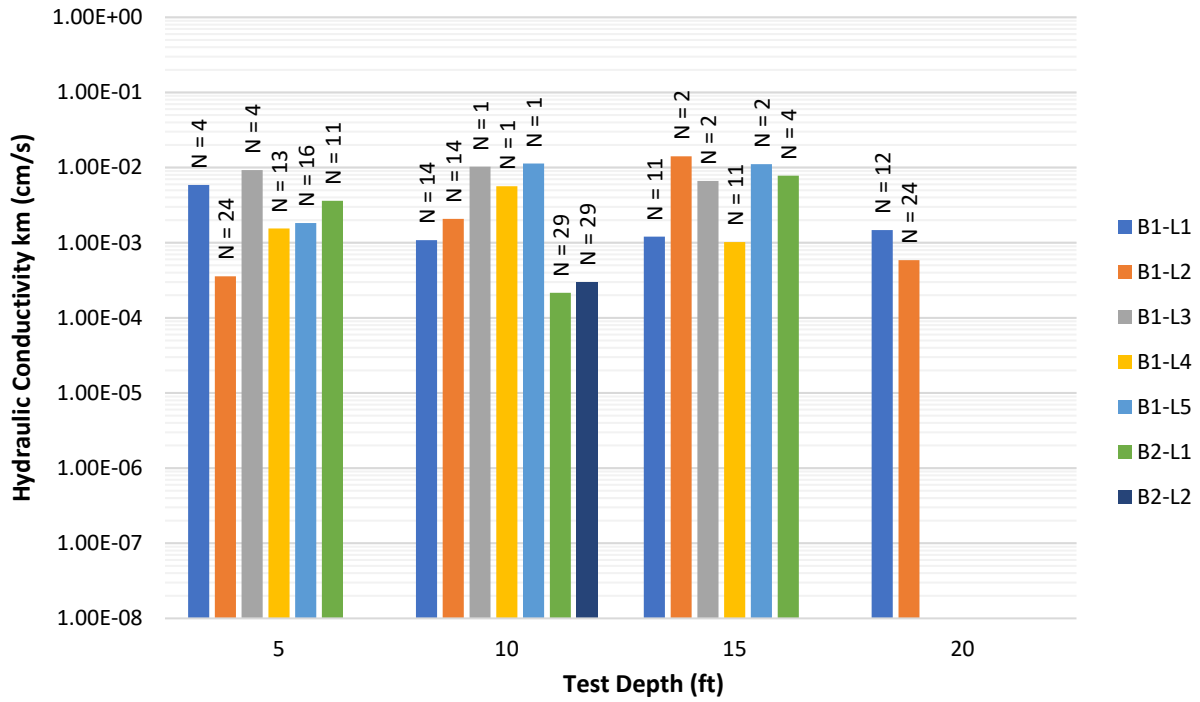

Figure 5-27. District 4 summary of VIP results.

Table 5-8. District 4 VIP summary of statistics.

Statistics	k_m (cm/s)
Mean	4.64×10^{-3}
Median	2.08×10^{-3}
Std Dev	4.43×10^{-3}
CV	0.95
Maximum	1.41×10^{-2}
Minimum	2.16×10^{-4}
Count	21

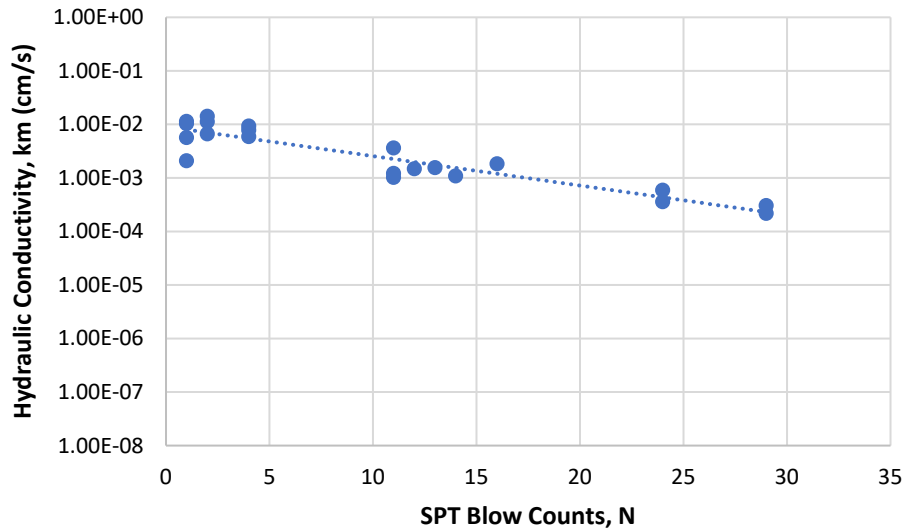

Figure 5-28. District 4 hydraulic conductivity plotted as a function of SPT blow counts.

5.5 District 5

District 5 VIP testing was completed at the I-75 Northbound rest area in Ocala. At the site, 22 VIP tests were completed from four different locations with the widest range of permeabilities measured in any district. The district’s consultant drill crew received onsite training and the SMO field specialists completed all VIP testing at the site. The SMO field crew also conducted CCH tests for comparison with the VIP tests. FDOT personnel and District 5 consultants also received onsite training. The test depths ranged from one to twenty feet with a large range of SPT blow counts recorded. The soils encountered were classified as A-3, A-2-6, A-6, A-7-5, and A-7-6.

5.5.1 PBS 4

At Location PBS 4, 10 VIP were completed from two different locations with depths ranging from one to twenty feet. The VIP test at one foot was conducted to see how VIP would perform as a potential replacement to time consuming double ring infiltrometer tests (Figure 5-29). The procedure included pushing the probe approximately 10 inches into the ground to allow the friction reducer to fully penetrate the surface. The falling head vessel is then attached and the AWJ connection is lifted two inches and held in place by a large wrench as depicted in in Figure 5-29. The VIP test procedure is then completed without saturation. The test results were calculated as unsaturated permeability. Sieve analyses are provided in Figure 5-30, and the VIP and CCH results are provided in Figure 5-31. The VIP measurements were consistent with changes in soil type and SPT blow counts at each location and depth. The VIP infiltrometer test compared well with the saturated permeability at a depth of five feet. No conventional infiltrometer tests were completed for direct comparison, however, the VIP approach required minutes to setup and perform the unsaturated test whereas double ring infiltrometer tests (conventional approach) requires six hours to complete the test per ASTM D3385-18 specifications. UF researchers recommend VIP approach should be investigated more thoroughly and compared to conventional methods before any conclusions are drawn on its viability. The

CCH tests were consistent with the soil type, SPT blow counts, and VIP measurements at a depth of five feet in an A-3 soil. However, the CCH results indicated a higher degree of permeability at depths of 10 and 15 feet. This is likely due to the wide range of soil types present at the site and the proximity of the CCH tests compared to the VIP tests. This trend was reversed at PBS 14 at a depth of 15 feet where the VIP measured higher permeabilities than the CCH tests in the same soil type as PBS 4 with blow counts similar to those measured at PBS 4 at a depth of 10 feet. Both test methods indicated decreasing permeability at the same depths, which is consistent with the soil types present and SPT blow counts measured.



Figure 5-29. VIP being used for an infiltrometer tests.

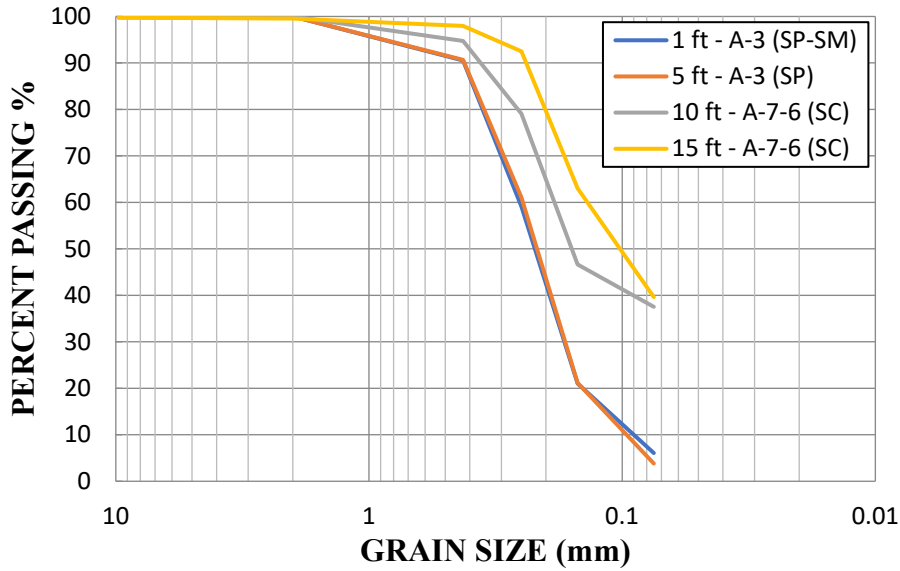

Figure 5-30. Location PBS 4 sieve analyses.

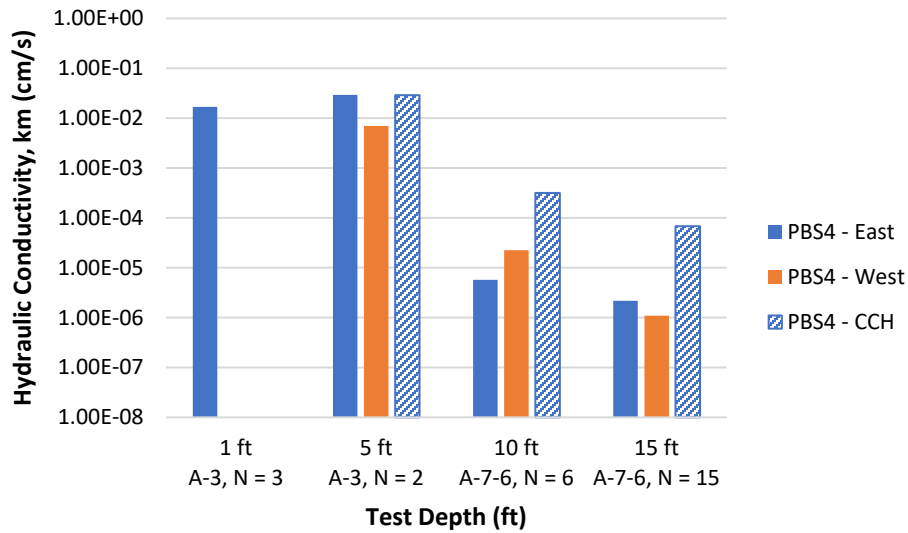

Figure 5-31. Location PBS 4 VIP and CCH results.

5.5.2 PBS 14

At location PBS 14, three different soil types were encountered A-3 at depths of 5 and 10 feet, A-7-6 at a depth of 15 feet, and A-7-5 at a depth of 20 feet. Sieve analyses are provided in Figure 5-32, and the VIP and CCH results are provided in Figure 5-33. The VIP and CCH tests were in agreement at each depth and were consistent with the soil type and density encountered. At a depth of 20 feet, VIP measured the lowest permeability recorded throughout the entire research project (and the prior VIP project), $K_m = 8.65 \times 10^{-7}$ cm/s (0.007 ft/day).

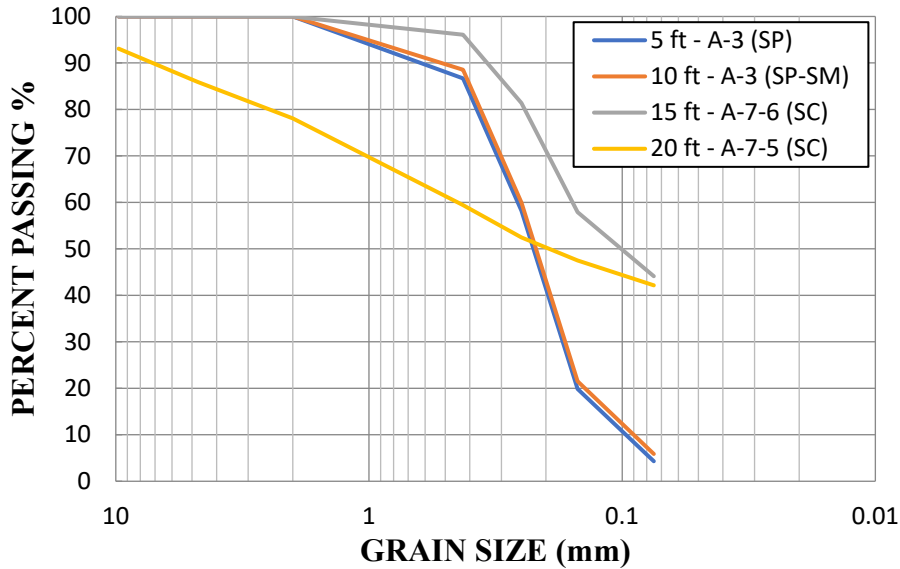

Figure 5-32. Location PBS 14 sieve analyses.

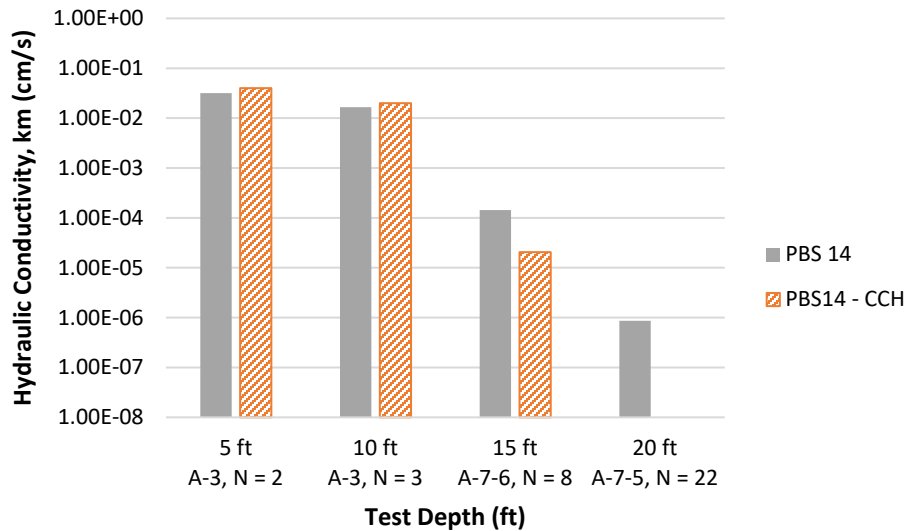

Figure 5-33. Location PBS 14 VIP and CCH results.

5.5.3 PBS 15

At location PBS 15, two different soil types were encountered A-3 at depths 5, 10, and 15 feet, and A-7-5 at a depth of 20 feet. Sieve analyses are provided in Figure 5-34, and the VIP and CCH results are provided in Figure 5-35. The VIP and CCH tests were in agreement at depths 5, 10, and 20 feet and were consistent with the soil type and density encountered. At a depth of 15 feet, the results were more variable, and the first VIP test appears low for the soil type and SPT blow counts. The trends of the data indicate the permeability increased moving away from the first VIP location at PBS 15, which is in agreement with the soil type and SPT data.

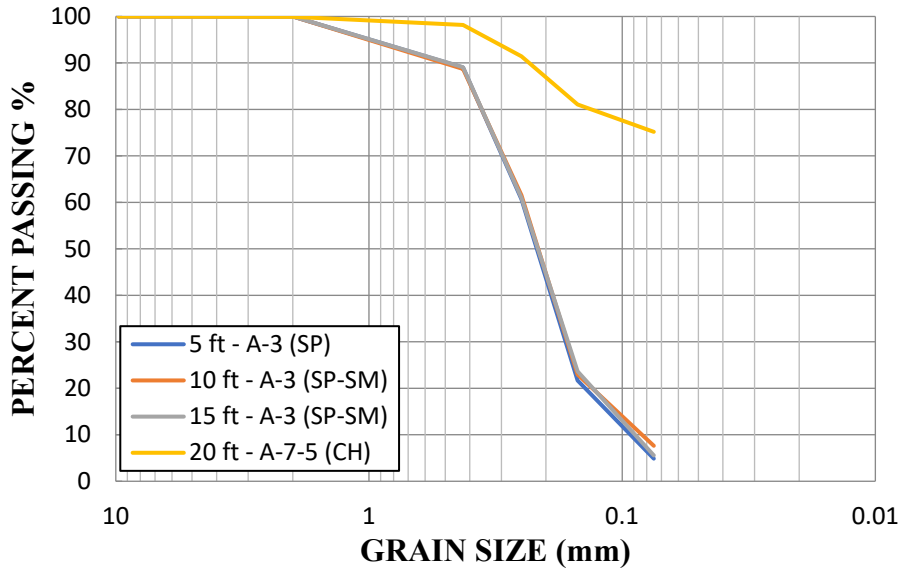

Figure 5-34. Location PBS 15 sieve analyses.

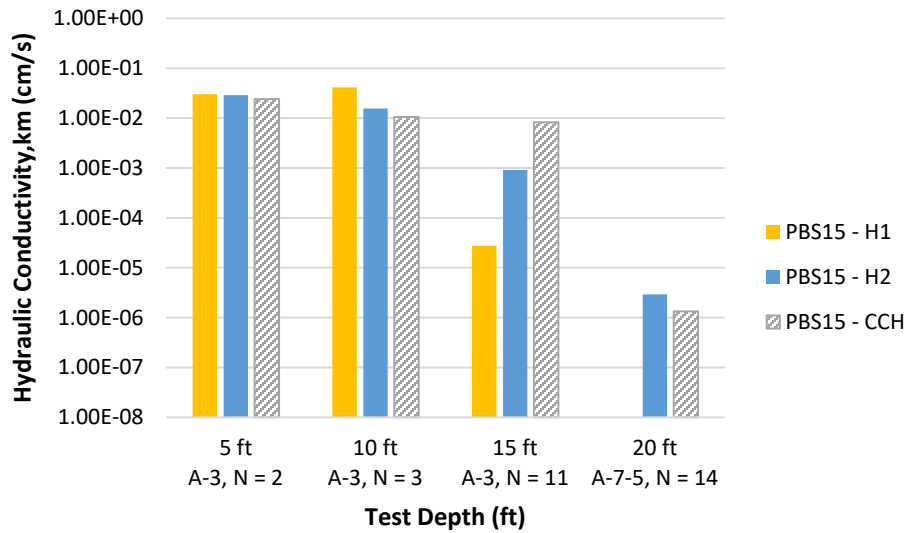

Figure 5-35. Location PBS 15 VIP and CCH results.

5.5.4 PBS 16

At location PBS 16, three different soil types were encountered A-3 at 5 feet, A-2-6 at 10 feet, and A-6 at a depth of 15 feet. Sieve analyses are provided in Figure 5-36, and the VIP and CCH results are provided in Figure 5-37. The VIP and CCH tests were in general agreement at each depth and were consistent with the soil type and density encountered. The CCH tests indicated slightly higher permeabilities at each test depth compared to the corresponding VIP test results.

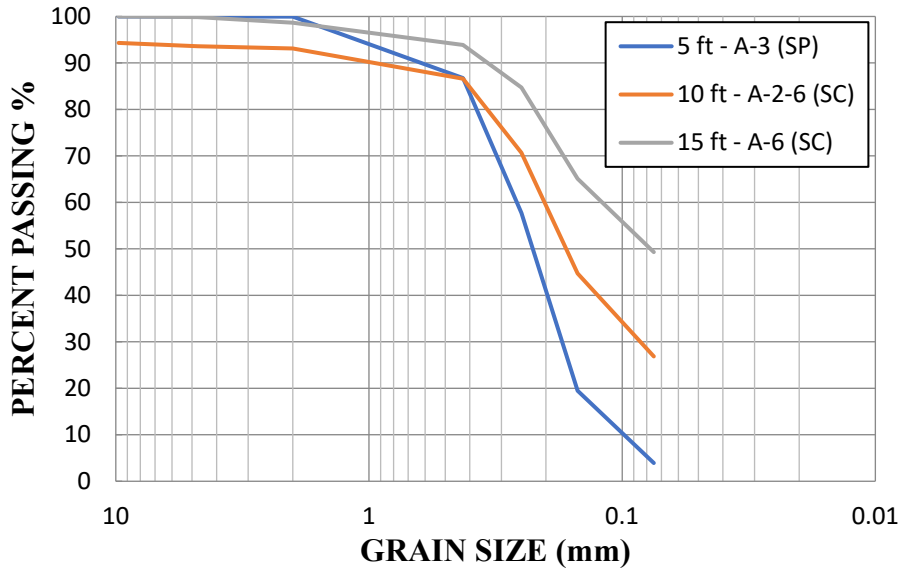

Figure 5-36. Location PBS 16 sieve analyses.

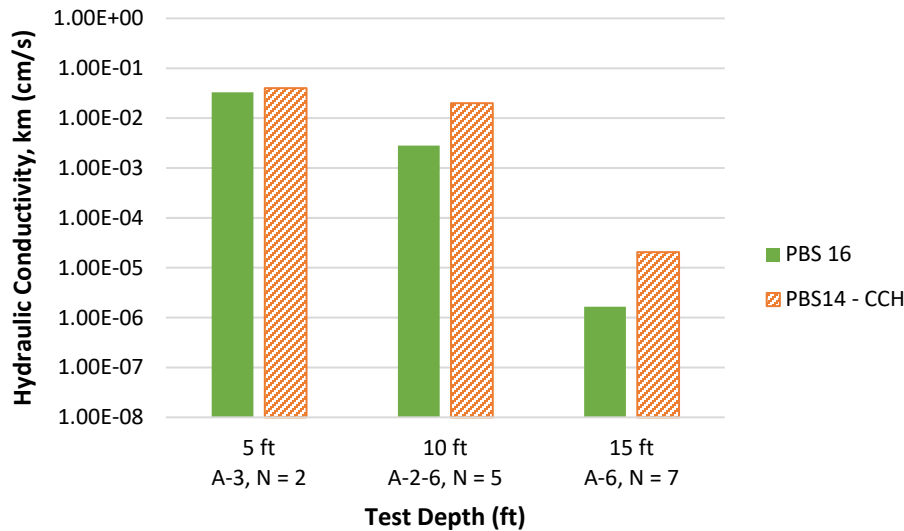

Figure 5-37. Location PBS 16 VIP and CCH results.

5.5.5 District 5 Summary

The District 5 summary of VIP test results are provided in Table 5-9 and Figure 5-38. The summary of statistics for District 5 is provided in Table 5-10. 21 VIP tests were completed in District 5. The permeabilities in District 5 ranged from $k_m = 8.65 \times 10^{-7}$ to 4.15×10^{-2} cm/s which was widest range measured in any district and covers nearly the full range encountered throughout the state of Florida. The mean permeability was 1.21×10^{-2} cm/s and the median permeability was 2.82×10^{-3} cm/s. The coefficient of variability was $CV = 1.19$ which was the second lowest degree of variability measured at any district. The widest range of permeability and second lowest CV is indicative of the layering present. In the top 10 feet the permeabilities

were generally high but at greater depths the soils generally transitioned from an A-3 soil to a clayey soils with lower permeabilities. A similar trend was also observed in District 2 which had the second widest range of permeabilities encountered with the third lowest CV value. This is consistent with the geographic locations of the Districts 2 and 5 sites, all of which were located in North Central Florida.

Table 5-9. Summary of VIP Test Results.

Site	Location	Depth (ft)	SPT N	Permeability		Soil Type	
				k_m (cm/s)	k_m (ft/day)	AASHTO	USCS
	PBS 4 H1T1	1	3	1.68×10^{-2}	41.71	A-3	SP-SM
	PBS 4 H1T2	5	2	2.92×10^{-2}	72.53	A-3	SP
	PBS4 H1T3	10	6	5.71×10^{-6}	0.01	A-7-6	SC
	PBS4 H1T4	15	15	2.18×10^{-6}	0.01	A-7-6	SC
	PBS 4 H2T1	5	2	6.99×10^{-3}	17.33	A-3	SP
	PBS 4 H2T2	10	6	2.25×10^{-5}	0.06	A-7-6	SC
	PBS4 H2T3	15	15	1.10×10^{-6}	0.00	A-7-6	SC
	PBS14 H1T1	5	2	3.19×10^{-2}	79.00	A-3	SP
I-75 Rest Area	PBS14 H1T2	10	3	1.66×10^{-2}	41.06	A-3	SP-SM
	PBS14 H1T3	15	8	1.43×10^{-4}	0.36	A-7-6	SC
	PBS14 H1T4	20	22	8.65×10^{-7}	0.00	A-7-5	SC
	PBS16 H2T1	5	2	3.29×10^{-2}	81.72	A-3	SP
	PBS16 H2T2	10	3	2.82×10^{-3}	7.00	A-2-6	SC
	PBS16 H2T3	15	7	1.66×10^{-6}	0.00	A-6	SC
	PBS15 H1T1	5	2	3.01×10^{-2}	74.56	A-3	SP
	PBS15 H1T2	10	3	4.15×10^{-2}	102.83	A-3	SP-SM
	PBS15 H1T3	15	11	2.76×10^{-5}	0.07	A-3	SP-SM
	PBS15 H2T1	5	2	2.87×10^{-2}	71.26	A-3	SP
	PBS15 H2T2	10	3	1.56×10^{-2}	38.72	A-3	SP-SM
	PBS15 H2T3	15	11	9.17×10^{-4}	2.27	A-3	SP-SM
	PBS15 H2T4	20	14	2.93×10^{-6}	0.01	A-7-5	CH

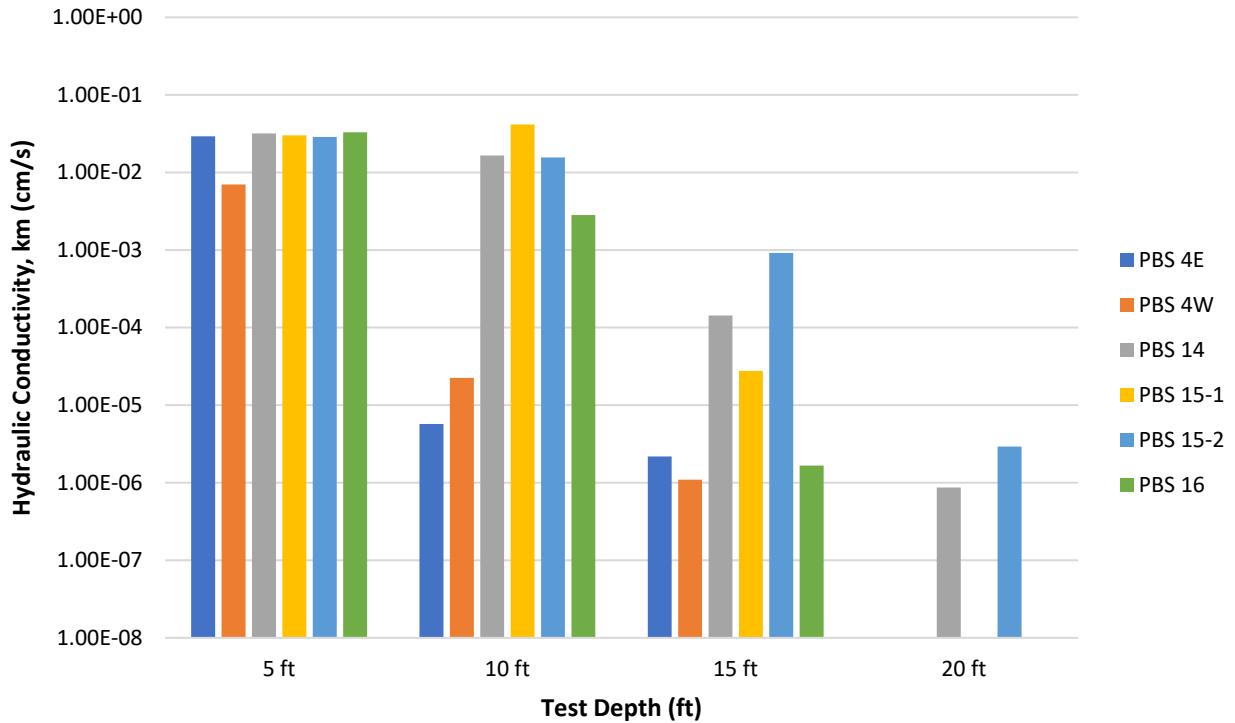

Figure 5-38. District 5 summary of VIP results.

Table 5-10. District 5 VIP summary of statistics.

Statistics	k_m (cm/s)
Mean	1.21×10^{-2}
Median	2.82×10^{-3}
Std Dev	1.45×10^{-2}
CV	1.19
Maximum	4.15×10^{-2}
Minimum	8.65×10^{-7}
Count	21

5.6 District 7 and Turnpike

District 7 and Turnpike VIP testing was completed in Brooksville and Veterans Expressway in Tampa. At the Brooksville site, nine VIP tests were completed from two different locations. The district's consultant drill crew received onsite training and completed all of the VIP testing at the Brooksville site. District 7 consultants and FDOT personnel also received onsite training at Brooksville. At the Veterans Expressway site, another district consultant drill crew received onsite training and completed six VIP tests. District 7 and turnpike consultants and FDOT personnel were provided onsite training at the Veterans Expressway site. Most of the time spent

at the Veterans site was used to provide onsite training as four different VIP training sessions were completed.

5.6.1 Brooksville

At the Brooksville site, two locations were tested. VIP tests at P-1 and P-2 were at the first locations and P-3 was at the second location. The soil type was A-2-4 at each location and depth except for one, in which the soil type was A-7-6. Sieve analyses are provided in Figure 5-39 and 5-41, and the VIP results are provided in Figure 5-40 and 5-42. The VIP results were consistent with the soils encountered and SPT blow counts at each location and depth except one depth, P2 at a depth of 10 feet. The permeability was lower than expected for the soil type and SPT blow counts. However, the soil recovered had the highest percentage of fines compared to all other depths at the location which may explain the lower permeability result. This result was also consistent with the VIP result in the same test location at a depth of 15 feet.

5.6.1.1 P-1 and P-2

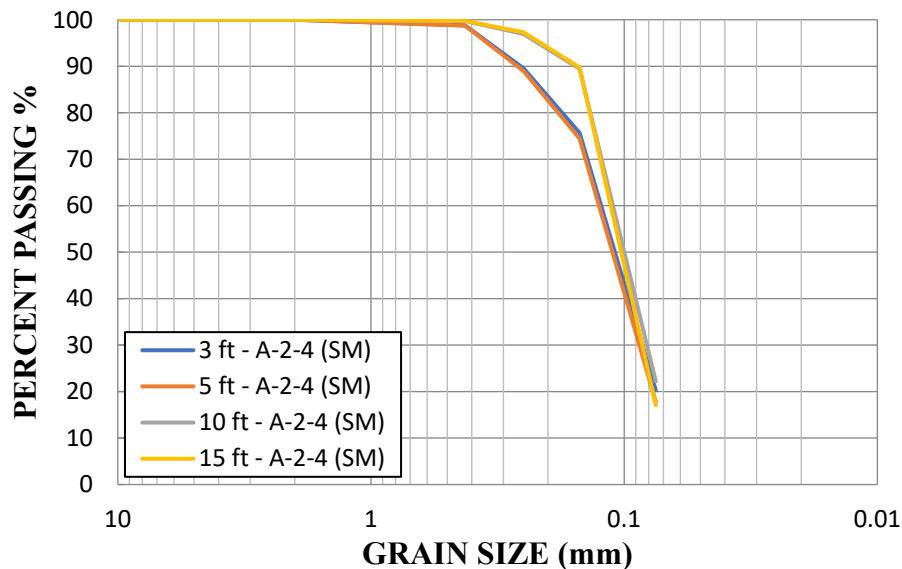

Figure 5-39. Brooksville Location P-1 and P-2 sieve analyses.

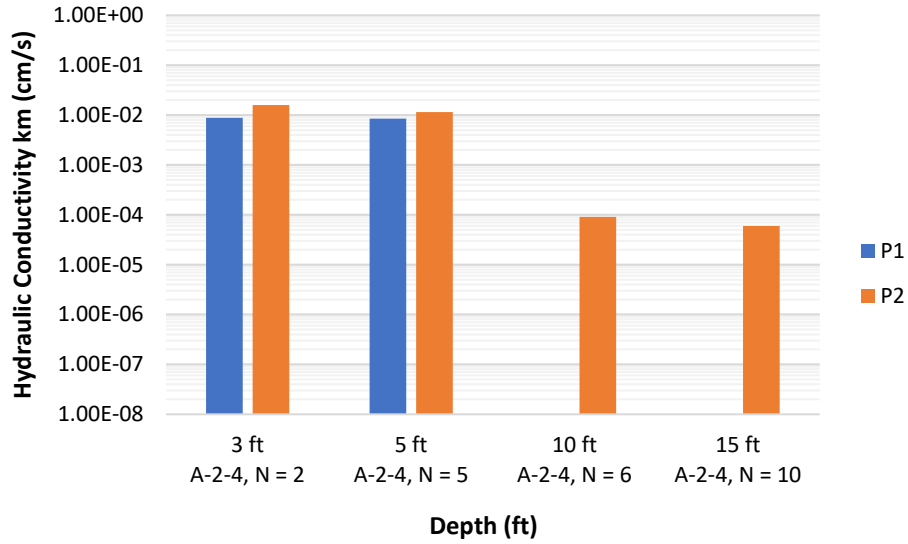

Figure 5-40. Brooksville Location P-1 and P-2 VIP results.

5.6.1.2 P-3

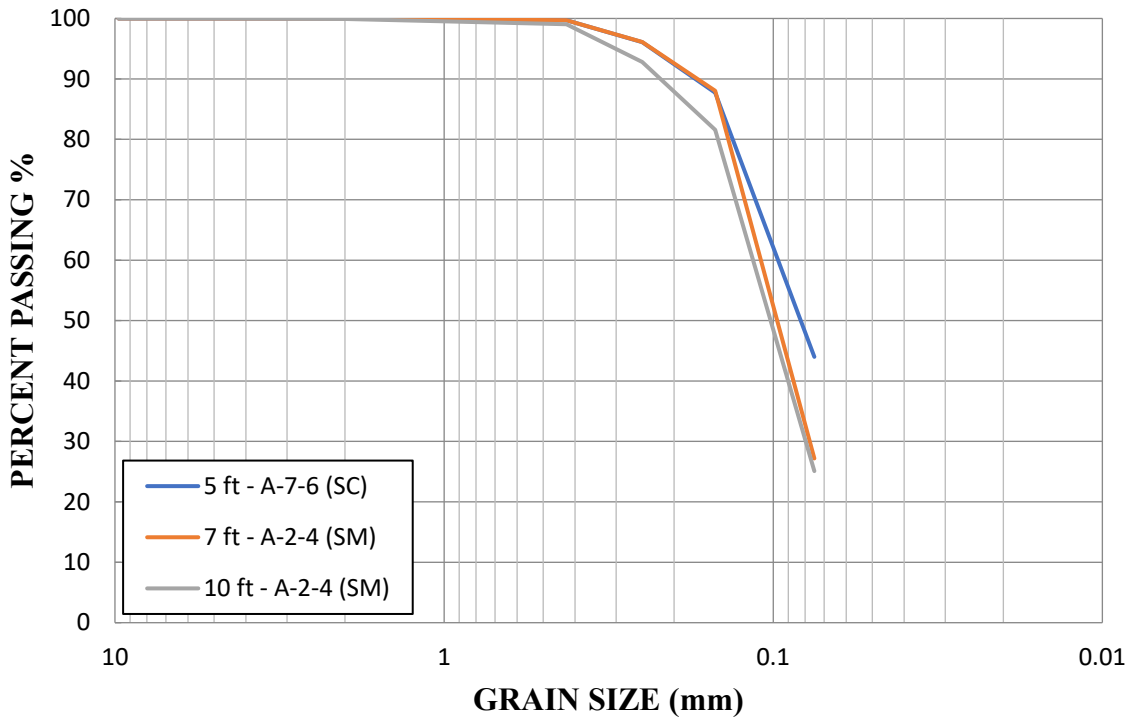

Figure 5-41. Brooksville Location P-3 sieve analyses.

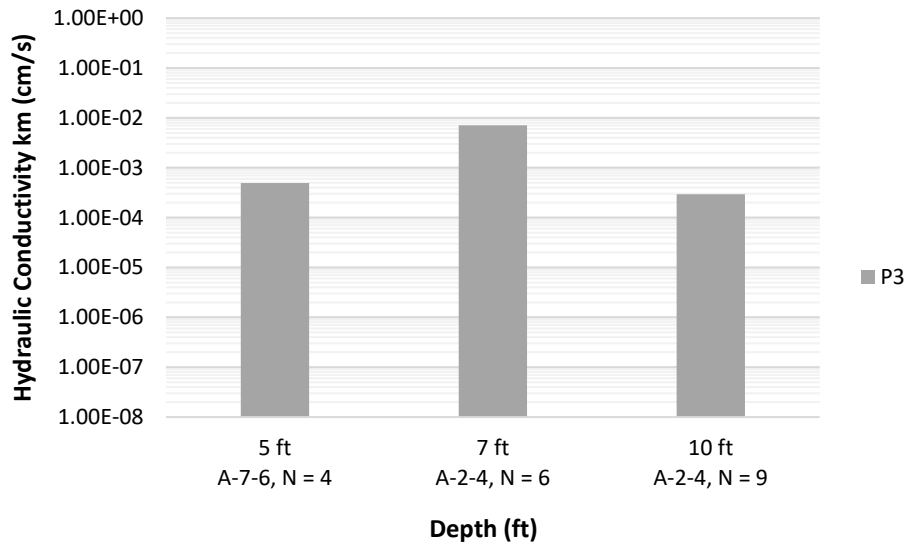

Figure 5-42. Brooksville Location P-3 VIP results.

5.6.2 District 7 and Turnpike – Veterans Expressway

At Veterans Expressway, the water table was 2.6 feet below ground surface which reduced the speed of the VIP tests. This is due to the low available head to push the water efficiently through the soil. Consequently, only six tests were completed with depths ranging from one to 15 feet. Historical data indicated a permeability range of $k_m = 7.37 \times 10^{-3}$ cm/s to 2.43×10^{-4} cm/s. The VIP results were consistent with the historical data and reflected the fine grain soil collected by a hand auger, shown in Figure 5-43. VIP results are provided in Figure 5-44.



Figure 5-43. Fine grained soil recovered by a hand auger at the Veterans Expressway site.

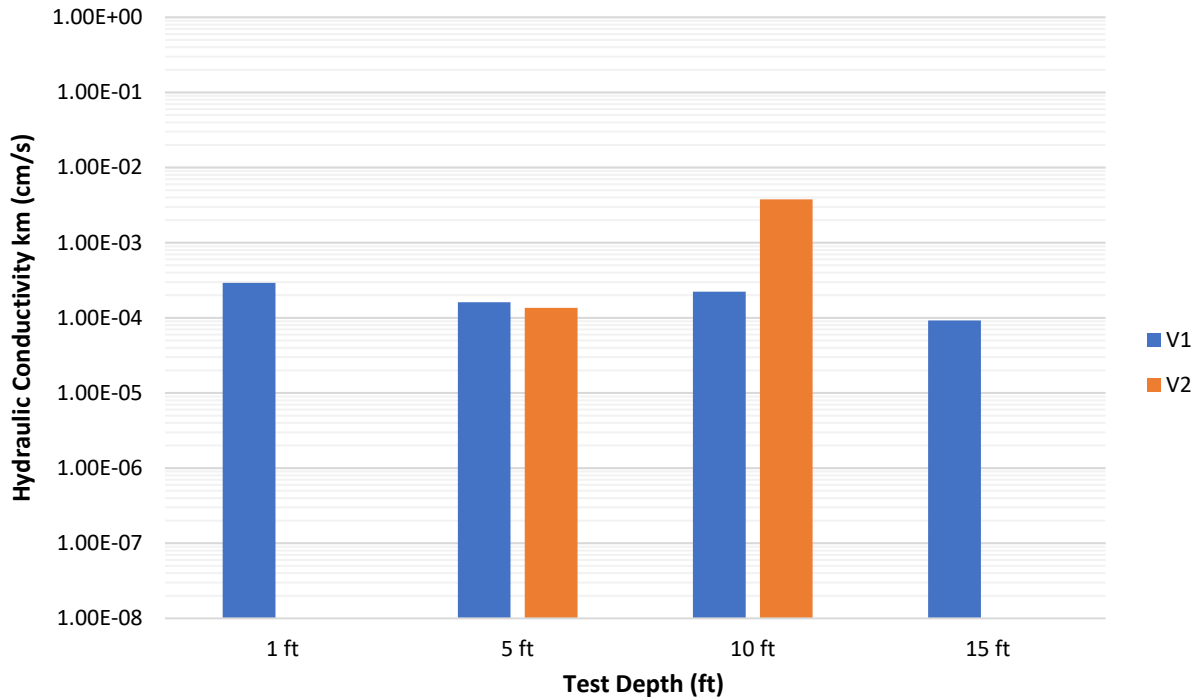

Figure 5-44. D7 Turnpike - Veterans Expressway VIP results.

5.6.3 District 7 and Turnpike Summary

The District 7 and Turnpike summary of VIP test results are provided in Table 5-11 and Figure 5-45. The summary of statistics for District 7 and Turnpike is provided in Table 5-12. Fifteen VIP tests were completed in District 7 and Turnpike. The permeabilities in District 7 and Turnpike ranged from $k_m = 5.98 \times 10^{-5}$ to 1.59×10^{-2} cm/s. The mean permeability was 3.82×10^{-3} cm/s and the median permeability was 2.95×10^{-4} cm/s. The coefficient of variability was $CV = 1.36$.

Table 5-11. District 7 summary of VIP results.

Site	Location	Depth (ft)	SPT N	Permeability		Soil Type	
				k_m (cm/s)	k_m (ft/day)	AASHTO	USCS
Brooksville	P1T1	3	2	8.79×10^{-3}	21.81	A-2-4	SM
	P1T2	5	5	8.47×10^{-3}	21.01	A-2-4	SM
	P2T1	3	2	1.59×10^{-2}	39.3	A-2-4	SM
	P2T2	5	5	1.15×10^{-2}	28.5	A-2-4	SM
	P2T3	10	6	9.08×10^{-5}	0.2	A-2-4	SM
	P2T4	15	10	5.98×10^{-5}	0.1	A-2-4	SM
	P3T1	5	4	4.94×10^{-4}	1.23	A-7-6	SC
	P3T2	7	6	7.13×10^{-3}	17.7	A-2-4	SM
	P3T3	10	9	2.95×10^{-4}	0.7	A-2-4	SM
Veterans Expy	V1-T1	1	N/A	2.92×10^{-4}	0.7	N/A	N/A
	V1-T2	5	N/A	1.62×10^{-4}	0.4	N/A	N/A
	V1-T3	10	N/A	2.23×10^{-4}	0.6	N/A	N/A
	V1-T4	15	N/A	9.21×10^{-5}	0.2	N/A	N/A
	V2-T1	5	N/A	1.36×10^{-4}	0.3	N/A	N/A
	V2-T2	10	N/A	3.77×10^{-3}	9.4	N/A	N/A

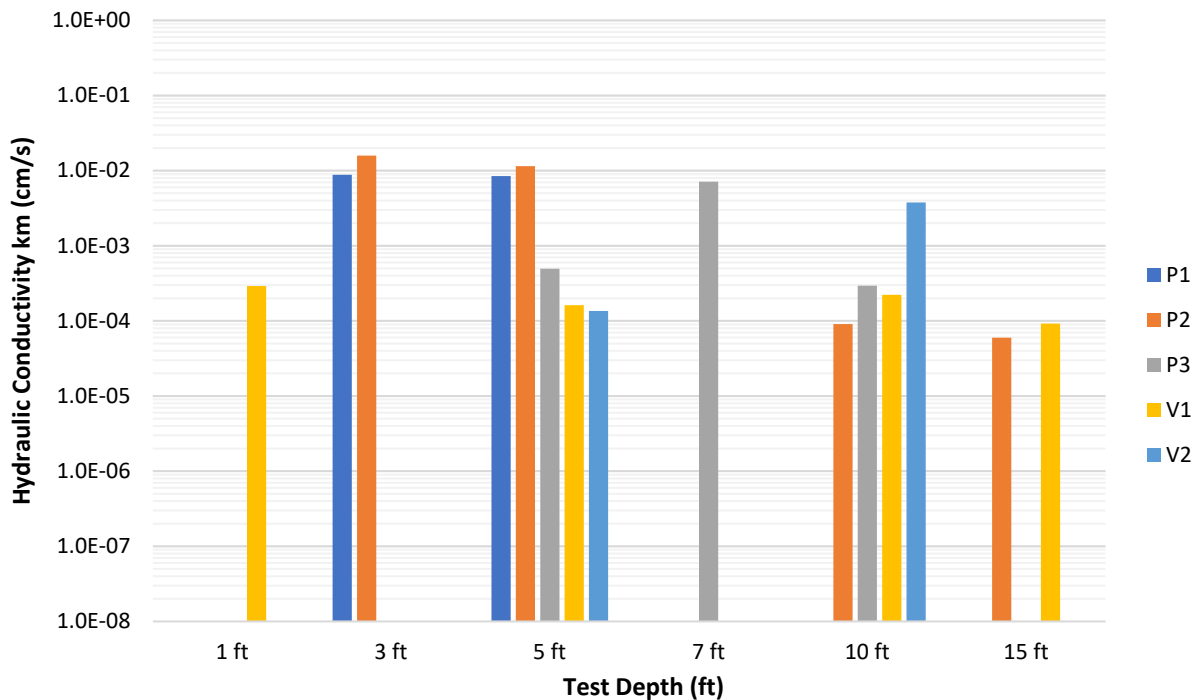

Figure 5-45. District 7 VIP results.

Table 5-12. District 7 VIP summary of statistics.

Statistics	k_m (cm/s)
Mean	3.82×10^{-3}
Median	2.95×10^{-4}
Std Dev	5.20×10^{-3}
CV	1.36
Maximum	1.59×10^{-2}
Minimum	5.98×10^{-5}
Count	15

5.7 Lower Permeability Limit

The lowest permeability measurement recorded in the field with the VIP probe was $k_m = 8.65 \times 10^{-7}$ cm/s. This measurement is considered the lower permeability limit for the probe, which is two orders of magnitude lower than the permeability limit of the original VIP probe design (BDV31-977-23). Therefore, the new VIP probe design expanded the upper and lower permeability limits beyond the constraints of the original VIP probe design.

5.8 Florida Summary of Results

In total, 109 valid VIP tests were completed from 10 different sites spread throughout the state of Florida. The VIP summary of statistics for each district and the state of Florida as a whole is provided in Table 5-13. The permeability throughout the state ranged from 8.65×10^{-7} cm/s to 4.68×10^{-2} cm/s. The mean permeability was 7.66×10^{-3} cm/s and the median permeability was 1.02×10^{-3} cm/s. The statewide coefficient of variability was $CV = 1.61$. The highest permeability was measured in Trenton located in District 2, and the lowest permeability recorded was measured in Ocala located in District 5.

Table 5-13. VIP summary of statistics for each FDOT district and all of Florida combined.

Statistics	Hydraulic Conductivity, k_m (cm/s)						
	D1	D2	D3	D4	D5	D7	Florida
Mean	8.17×10^{-3}	1.45×10^{-2}	2.68×10^{-4}	4.64×10^{-3}	1.21×10^{-2}	3.82×10^{-3}	7.66×10^{-3}
Median	2.13×10^{-3}	5.87×10^{-4}	1.07×10^{-4}	2.08×10^{-3}	2.82×10^{-3}	2.95×10^{-4}	1.02×10^{-3}
Std Dev	1.31×10^{-2}	1.84×10^{-2}	3.50×10^{-4}	4.43×10^{-3}	1.45×10^{-2}	5.20×10^{-3}	1.24×10^{-2}
CV	1.61	1.27	1.31	0.95	1.19	1.36	1.61
Max	4.23×10^{-2}	4.68×10^{-2}	1.15×10^{-3}	1.41×10^{-2}	4.15×10^{-2}	1.59×10^{-2}	4.68×10^{-2}
Min	1.69×10^{-5}	3.45×10^{-6}	9.48×10^{-6}	2.16×10^{-4}	8.65×10^{-7}	5.98×10^{-5}	8.65×10^{-7}
Count	18	19	15	21	21	15	109

When assessing the results of the newly developed VIP probe, it is important to analyze each result locally and compared to conventional site investigation methods such as soil classifications, SPT blow counts, and conventional methods of permeability determination. This was conducted in the prior sections of this chapter. Similarly, it is also of importance to assess

the results of the VIP probe statewide and to analyze the results based on geological environments and the soils commonly encountered within each region of the state. In Figure 5-46, cumulative frequency distributions are provided for each FDOT district and the state of Florida as a whole. Figures 5-47 through 5-52 provide the cumulative frequency for individual districts compared to the Florida distribution.

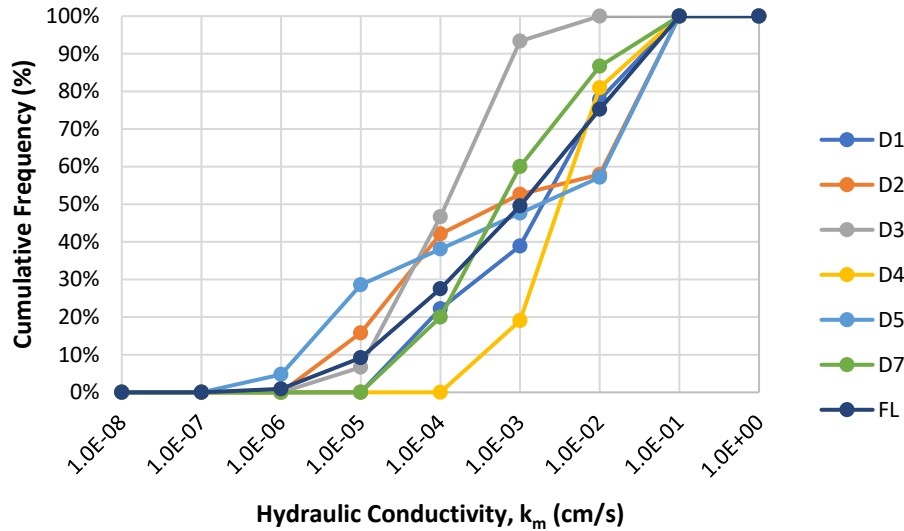

Figure 5-46. VIP cumulative frequency distributions for each FDOT district and Florida.

The analysis begins in the northern part of Florida, starting with District 3 located in the panhandle. Historically, clayey soils are commonly encountered and therefore a lower permeability is expected. This is the result that was found as the distribution indicates 93% of soils encountered had a $k_m < 1 \times 10^{-3}$ cm/s and the lowest range of permeabilities were encountered throughout the state as expected.

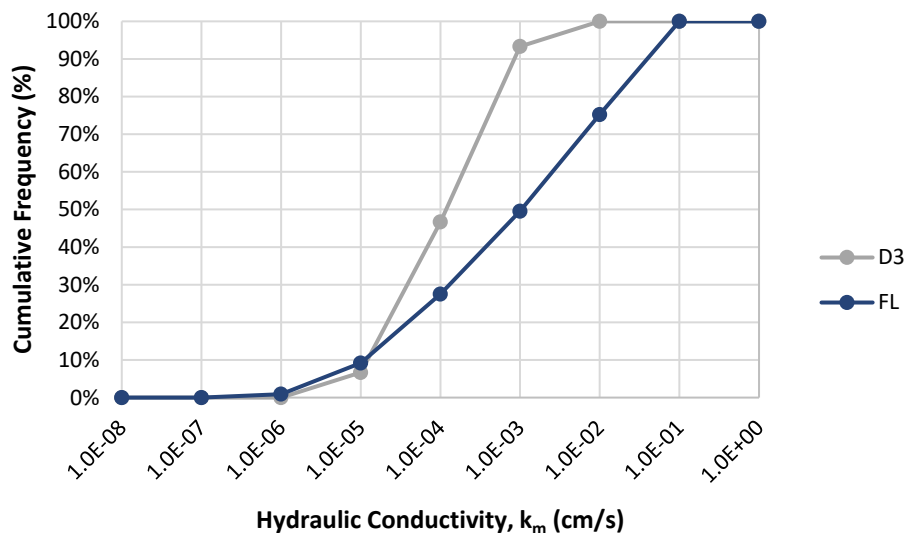

Figure 5-47. VIP cumulative frequency distributions for FDOT District 3 and Florida.

Moving further south and into northern Central Florida, District 2, the range of permeabilities increased and was the second widest range found throughout the state. This was also the expected trend as moving from North Florida to South Florida, the soils begin to transition from predominately clayey soils to granular soils with minimal fines. Due to the geographic location, it was expected that District 2 would be a transitional location and include a wide variety of soil types.

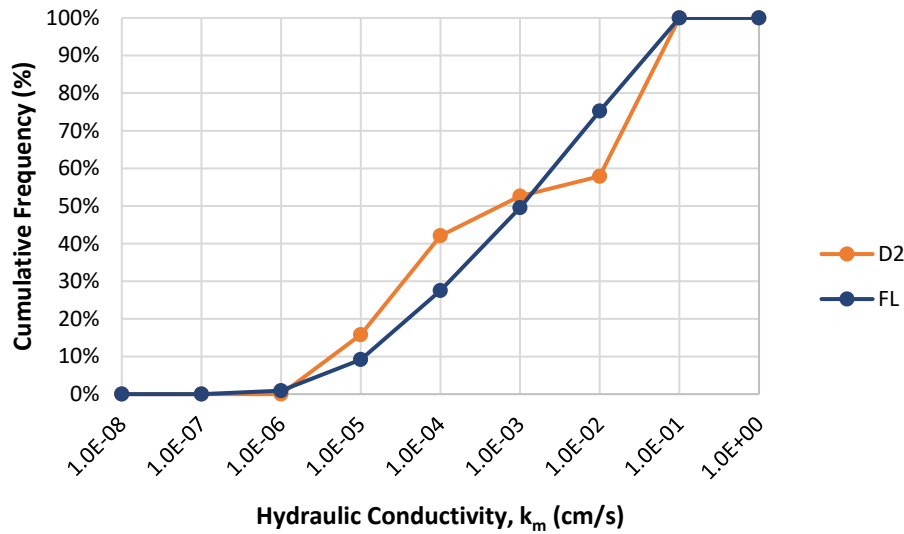

Figure 5-48. VIP cumulative frequency distributions for FDOT District 2 and Florida.

Similar trends observed in District 2, were also observed in District 5 which is located just south of District 2. District 5 is also located in Northern Central Florida and the frequency distribution indicates the widest range of permeabilities and closely resembles the distribution from District 2. The lowest permeability measured statewide was located in District 5.

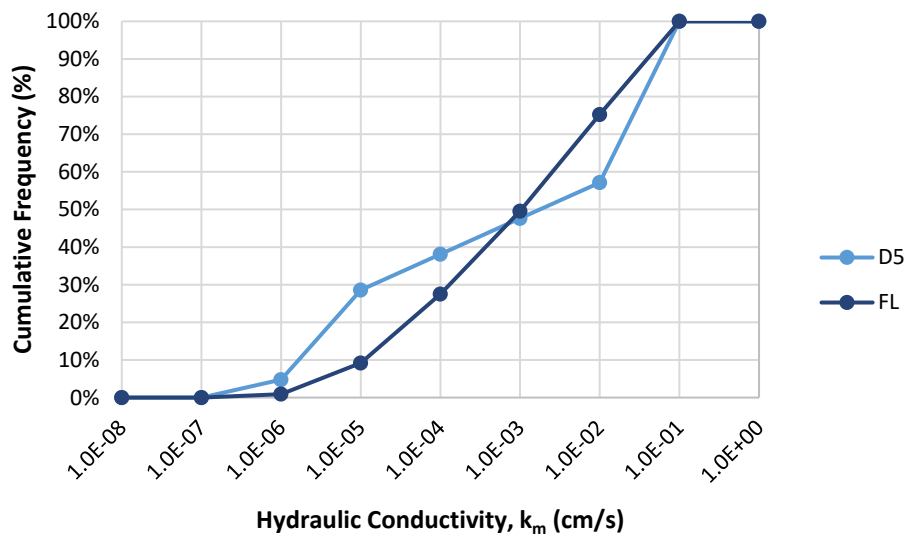

Figure 5-49. VIP cumulative frequency distributions for FDOT District 5 and Florida.

District 7 was considered next moving south as the Brooksville site is located further north than the District 1 site in Bartow. The Bartow site is close to the same latitude as the Veterans Expressway site located in Tampa in District 7. Therefore, District 7 contained soil collected further north than District 1. In District 7, the lowest permeability measured was higher than the lowest permeability measured in Districts 3, 2, and 5. The distribution provided in Figure 5-50 also shows the range of permeabilities is beginning to narrow and move towards the higher values.

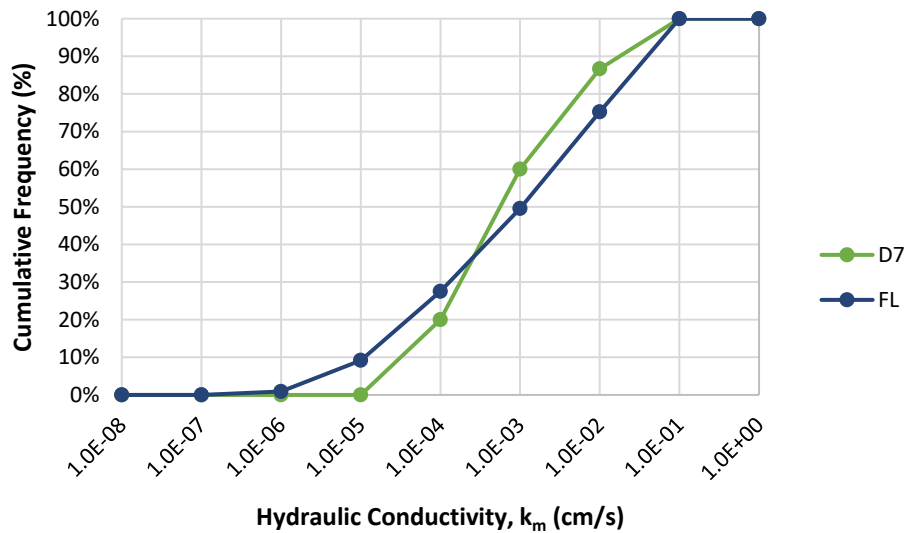

Figure 5-50. VIP cumulative frequency distributions for FDOT District 7 and Florida.

Moving further south to District 1, the low end of the permeability range was similar to District 7, but a larger percentage of higher permeability soils were encountered as expected. This can be observed when comparing the percentages of soils with a permeability above 1×10^{-3} cm/s. In District 1, 61% of the soils were above this level and in District 7 40% of soils were above this level.

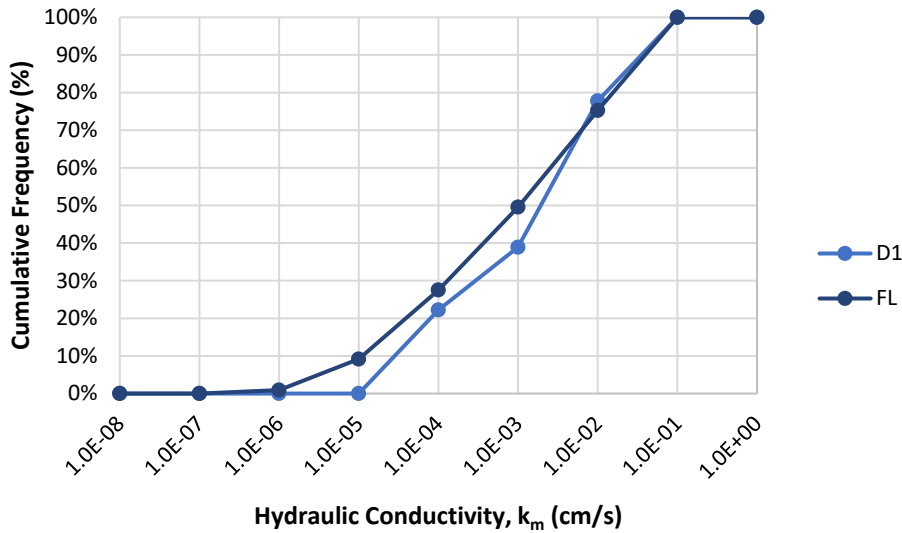

Figure 5-51. VIP cumulative frequency distributions for FDOT District 1 and Florida.

Finally, moving to the southernmost district, District 4 in West Palm Beach, the highest range of permeabilities was measured as expected. The lowest permeability measured was higher than the lowest permeability in any other district and 81% of the soils had a permeability greater than $k_m = 1 \times 10^{-3}$ cm/s. This is due to the presence of lower fines granular soils lacking any significant amounts clay in South Florida. Therefore, not only did the VIP probe compare well locally, but the results are also in agreement with historical statewide observations for soil types encountered and the range of permeabilities measured. This is a strong indicator that the testing equipment and test method developed are consistent, reliable, and accurate.

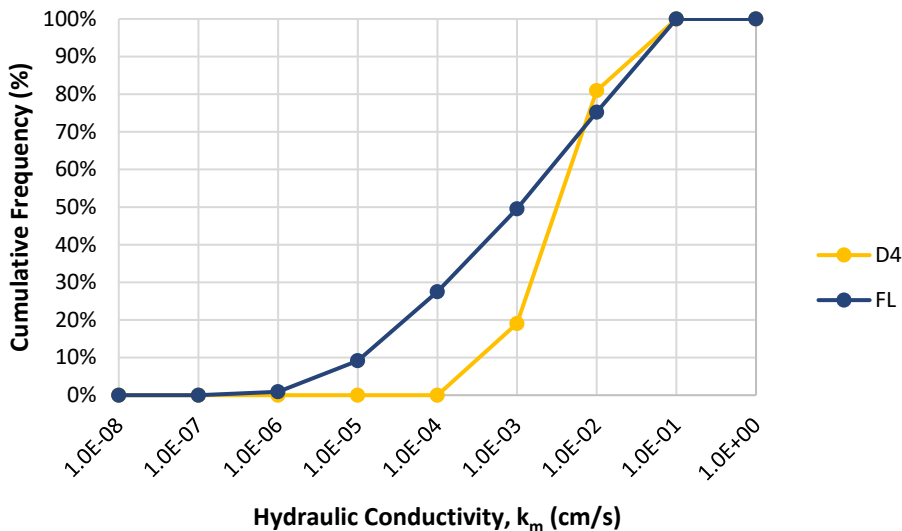

Figure 5-52. VIP cumulative frequency distributions for FDOT District 4 and Florida.

The last component of the analysis was to assess the VIP results based on the soil types encountered to determine if the results follow the expected trends. Table 5-14 presents soil classifications based on the coefficient of permeability according to Terzaghi and Peck (1967).

Table 5-14 provides the summary of statistics for the VIP results with the soils encountered broken down into three categories based on AASHTO specifications: Fine Sand (A-3), Silty or Clayey Sands (A-2), and Clayey Soils (A6 and A7; “A-6/7”). Figure 5-53 provides the VIP hydraulic conductivity cumulative frequency distributions for each soil type.

Table 5-14. Soil classification based on coefficient of permeability (Terzaghi and Peck 1967).

Degree of Permeability	Value of k (cm/s)
High	Over 1×10^{-1}
Medium	1×10^{-1} to 1×10^{-3}
Low	1×10^{-3} to 1×10^{-5}
Very Low	1×10^{-5} to 1×10^{-7}
Practically Impermeable	Below 1×10^{-7}

Table 5-15. VIP permeability summary of statistics for soil types encountered during the project.

Statistics	Fine Sand	Silty or Clayey Sands	Clayey Soils
	A-3	A-2	A-6/7
Mean	1.30×10^{-2}	3.00×10^{-3}	5.41×10^{-5}
Median	6.81×10^{-3}	2.95×10^{-4}	5.71×10^{-6}
Std Dev	1.46×10^{-2}	4.84×10^{-3}	1.27×10^{-4}
CV	1.12	1.61	2.36
Maximum	4.68×10^{-2}	1.59×10^{-2}	4.94×10^{-4}
Minimum	2.76×10^{-5}	9.48×10^{-6}	8.65×10^{-7}
Count	48	19	15

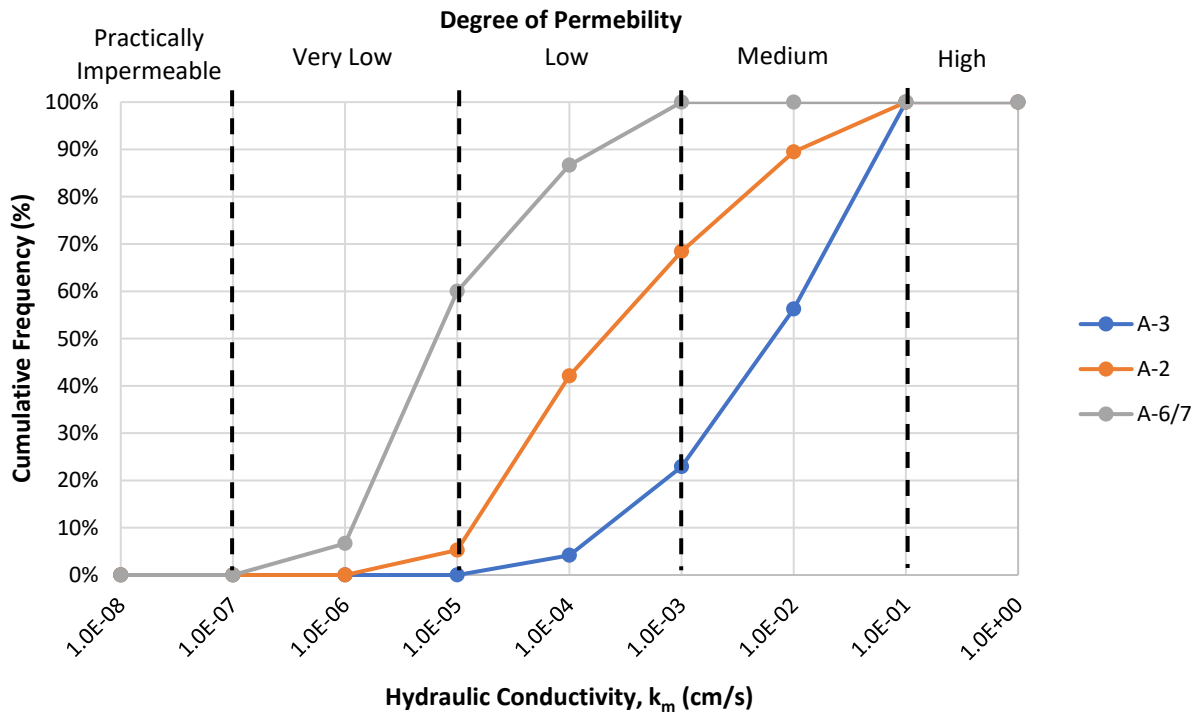

Figure 5-53. VIP cumulative frequency distributions for Florida based on AASHTO soil type.

From Table 5-14 it is first observed that the VIP probe's upper permeability limit ($k_m = 1.07 \times 10^{-1}$ cm/s) approximately defines the threshold between a high and medium degree of permeability. From Table 5-15, the VIP results indicate that A-3 soils (Fine sand) produced the highest permeability on average, A-2 soils (silty or clayey sands) produced the second highest permeability on average, and the A-6/7 soils (clayey soils) produced the lowest permeability on average which is the expected trend. From Table 5-14 and Figure 5-53 it is observed that the degree of permeability for the A-6/7 (clayey) soils ranged from low (40% of clayey soils) to very low (60% of clayey soils); 77% of the A-3 (fine sand) soils had a medium degree of permeability and only 23% of A-3 soils had a low degree of permeability; for the A-2 (silty or clayey sand) soils 63% had a low degree of permeability, 32% had a medium degree of permeability, and 5% had a very low degree of permeability. These results also reflect the expected trends as A-3 soils contain the least amount of fines (% passing $\leq 10\%$), A-6/7 soils contain the most fines (% passing $> 35\%$), and A-2 soils contain a transitional amount fines between A-3 and A-6/7 soils ($35\% \geq$ % passing $> 10\%$). Interestingly, the range of fines measured in the laboratory and encountered during VIP testing were 1.3% to 8.4% fines for the A-3 soils, 11% to 34.5% fines for the A-2 soils, and 36.3% to 81.5% fines for the A-6/7 soils which covers nearly the entire range of fines for each soil type. Therefore, the VIP test results from FM 5-614 are indicating the appropriate degree of permeabilities for each soil type over nearly the entire range of fines based on AASHTO classifications. Furthermore, the permeability results that were achieved with the VIP probe ranged from the upper limit of a medium degree of permeability to the lower limit of a very low degree of permeability (i.e., High Permeability $>$ VIP $k_m >$ Practically Impermeable). This is reflective of the entire range that is typically considered in most transportation engineering design applications because measuring $k_m > 1 \times 10^{-1}$ cm/s or $k_m < 1 \times 10^{-7}$ cm/s is

generally only required for specialized applications. Furthermore, the VIP was capable of measuring this range using only a simplified falling head test approach, whereas Bowles (1984; referenced in FDOT 2021) recommended transitioning from a falling head test below a permeability threshold of $k_m = 1 \times 10^{-3}$ cm/s to a constant head test above the threshold. The results of this analysis further support the simplicity, viability, and accuracy of the VIP test procedures developed for transportation applications and also support that a shape factor of $F = 3D$ is appropriate for the VIP probe.

Also of interest, the A-6/7 soils all had permeabilities lower than 1×10^{-3} cm/s which is the threshold identified by Bowles (1984; referenced in FDOT 2021) to transition test methods and has been used in the discussion as a threshold to define higher and lower permeability soils. This is also the approximate threshold of when the saturation period is effective for VIP testing. Figure 5-54 is from an investigation conducted during the prior VIP project (BDV31-977-23) where permeability was measured during saturation (Saturation Hydraulic Conductivity) and compared to the measurements taken during the actual VIP tests (VIP Hydraulic Conductivity) once the soil had been saturated. From Figure 5-54, it can be seen that the same approximate permeability was measured during saturation and during the VIP test when the permeability was $k_m \geq 1 \times 10^{-3}$ cm/s. However, as the VIP test permeability fell below the threshold, the permeability measured during saturation was higher than the actual VIP test results after saturation was complete. This is believed to be a result of the fines content shifting within the network of soil voids from the flow of water. Generally, the permeability of soils increases during initial saturation compared to the start of a permeability test as more voided space is opened up from the introduction of water. As the fines content is shifted within the network of voids, some voids are clogged in which water cannot pass through. The permeability will eventually stabilize at a lower value after saturation is complete for soils with a higher fines content. However, the initial increase in permeability during saturation compared to the start of the test was not captured during these trials because only one test was performed during the saturation period. These observations further support the use of the 15-minute saturation period per FM 5-614 for soils with a higher fines content but also indicates that soils with minimal fines, such as A-3 soils, may not require the full saturation period or any saturation period. However, more testing should be conducted to confirm these observations.

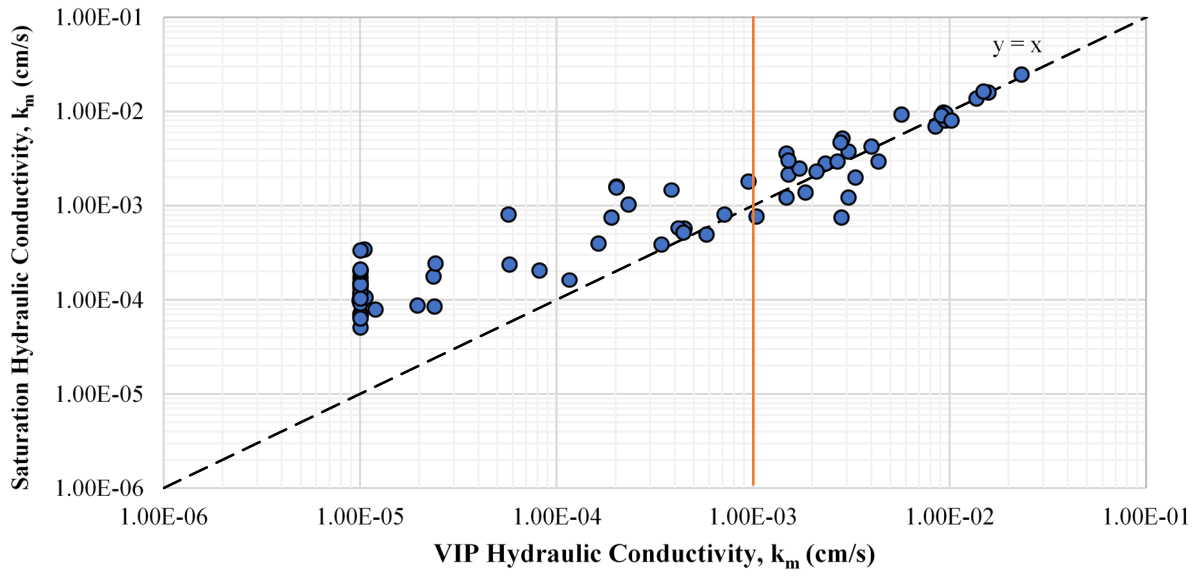

Figure 5-54. Saturation hydraulic conductivity vs. VIP test hydraulic conductivity.

6. Conclusions

This research was an implementation project that built off the success of the prior work completed in BDV31-977-23. The focus of this research was to improve the Vertical In situ Permeameter (VIP) probe and accompanying equipment and implement VIP testing statewide within each FDOT district. Based on the results of this study the following conclusions can be drawn.

- The new robust probe design is much improved compared to the original design. The new design includes only four pieces with two threaded connections which reduced the assembly time to less than 30 seconds. With the new design, fabrication costs were reduced by 20% and it is easier to ensure each piece is concentric and provides proper internal alignment to reduce stress concentrations during advancement. The new robust design now allows SPT hammering and can withstand a larger axial force during direct push advancement.
- The new falling head vessel design is much improved compared to the original design. For the new design, aluminum plates were used instead of steel (original) to reduce the weight for onsite transport, a greater wall thickness was provided in the falling head vessel to provide a more robust design, a more robust tripod stand was incorporated to improve the durability, and all pieces were designed to be individual and removable which allows the vessel components to be more easily replaced if damaged.
- The new probe design functioned well in a large variety of Florida soils including A-3, A-2-4, A-2-6, A-2-7, A-6, A-7-5, and A-7-6. The measured permeability range with the new probe design, $k_m = 8.65 \times 10^{-7}$ cm/s to 1.07×10^{-1} cm/s, is much improved from the original design, $K_m = 1.00 \times 10^{-5}$ cm/s to 7.48×10^{-2} cm/s. The new measurable permeability range is from the upper limit of a medium degree of permeability to the lower limit of a very low degree of permeability (i.e., High Permeability > VIP k_m > Practically Impermeable) which covers the entire range that is typically considered in most applications for transportation engineering design.
- The new VIP design performed well in a large range of depths (one to 20 feet) and functioned well above and below the water table. It was observed that higher ground water tables increase the test times due to the lower head to efficiently push the water through the soil.
- The new VIP probe along with training of the test method were delivered to each district. Based on the feedback received from consultants and FDOT personnel, the VIP method was identified as very efficient and easy to implement and could serve as a potential replacement for other field permeability methods used in Florida; thereby, providing continuity for k_m measurements statewide.
- The new Florida test method (FM 5-614) is much improved and incorporates input from Florida geotechnical engineers across the state. Feedback on the VIP online tutorial indicated that the instructional video is very thorough and easy to follow.
- VIP compared well to the soil classifications, SPT blow counts (soil density), and comparative field permeability test methods.
- VIP identified the correct permeability trends statewide based on historical data and the geological formations present within each FDOT district.
- VIP identified the correct permeability trends based on soil type and provides an ideal measurable permeability range for most transportation engineering applications.

- The previously developed shape factor of $F = 3D$ was found to be accurate during this research.

7. Recommendations

The following recommendations are based on this study's findings:

- Testing recommendations based on observations made during statewide testing:
 - Check O-rings in between test locations when encountering a lot of silty soils because fine grain soils can reduce the life of the probe tip's O-rings.
 - Check O-rings between tests when operating in very cold weather, because O-rings can become stiff in cold weather and shearing may occur.
 - Inspect the probe and drill rods throughout the testing and between test locations to ensure no debris or grease buildup is present within the drill string or probe that may cause false readings. If present, the probe and/or drill rods will need to be disassembled and cleaned prior to further testing.
 - High water tables lead to longer test times due to reduced head to push the water efficiently through soil. Therefore, when high GWT are expected, plan for fewer VIP tests in the time allotted.
 - Rock fragments can score the probe, and it is recommended to use a file to smooth any roughened surfaces. The probe should be rotated after cleaning and/or filing to ensure concentric rotation without binding.
 - Electric tape can be used to keep the probe closed when advancing down an open borehole.
 - The more you use the probe, the better it operates. When the probes are first manufactured, some components may contain sharp edges that may reduce the life of O-rings. After the probe is continuously used, the sharp edges will begin to smooth, which will extend the life of the O-rings.
 - Use clean water during VIP tests, water with soil may reduce the permeability measured.
- Research Recommendations:
 - The upper permeability limit and VIP procedures submitted by UF should be updated to incorporate and emphasize the normalization of permeability readings based on water temperature and viscosity. This will improve the data collected in future VIP tests by accounting for seasonal water temperature effects and provide continuity across the state.
 - Test more A-2 and A-4 through A-7 soils. Approximately 60% of the soils tested with soil classifications available were A-3 soils (48 of 81 tests). It would be ideal to gather the same amount of test data for A-2 (Silty and Clayey Sands) soils and A-4 through A-7 (Clayey soils) soils. However, the test times are expected to be much greater when testing these soil types, which needs be considered for future tests.
 - The VIP test method should be used in design statewide. From the results of this research effort, the VIP method was found to be accurate and reliable statewide in a wide variety of soil types, at multiple test depths, above and below the GWT. The developed equipment and method allow more data to be collected with less effort while producing minimal soil disturbance, which is ideal for collecting in situ permeability data. Conventional methods (laboratory and borehole) require more time and effort and often induce soil disturbance, which can create discrepancies in the permeability data collected. Furthermore, it was observed that

each consultant drill crew typically comprised three field technicians. When performing the VIP tests only two field technicians were needed. Therefore, VIP would reduce the number of field technicians required, allow far more test data to be collected in the same amount of time with less effort compared to conventional methods, and provide more reliable and accurate in situ permeability data.

References

- ASTM (2016), D5084-16a, Standard Test Methods for Measurement of Hydraulic Conductivity of Saturated Porous Materials Using a Flexible Wall Permeameter, ASTM International, West Conshohocken, PA.
- Bloomquist, D., A. Viala, and M. Gartner (2007), Development of a Field Permeability Apparatus, Florida Department of Transportation, Tallahassee, FL.
- Bo, M., A. Arulrajah, M. Leong, S. Horpibulsuk, and M. Disfani (2014), Evaluating the in-Situ Hydraulic Conductivity of Soft Soil under Land Reclamation Fills with the BAT Permeameter, *Engineering Geology*, 168(January), 98-103.
- Bohling, G., G. Liu, S. Knobbe, E. Reboulet, D. Hyndman, P. Dietrich, and J. Butler (2012), Geostatistical Analysis of Centimeter-Scale Hydraulic Conductivity Variations at the MADE Site, *Water Resources Research*, 48(2), W02525.
- Butler, J., and S. Mathias (2006), An Improvement on Hvorslev's Shape Factors, *Geotechnique*, 56(10), 705-706.
- Butler, J., P. Pietrich, V. Wittig, and T. Christy (2007), Characterizing Hydraulic Conductivity with the Direct-Push Permeameter, *Groundwater*, 45(4), 409-419.
- Chang, C., and C. Chen (2002), An Integral Transform Approach for a Mixed Boundary Problem Involving a Flowing Partially Penetrating Well with Infinitesimal Well Skin, *Water Resources Research*, 38(6), 7-1.
- Chang, C., and C. Chen (2003), A Flowing Partially Penetrating Well in a Finite-Thickness Aquifer: A Mixed-Type Initial Boundary Value Problem, *Journal of Hydrology*, 271(1-4), 101-118.

- Chapuis, R., and D. Chenaf (2008), Comment on 'Shape Factors for Constant-Head Double-Packer Permeameters' by S.A. Mathias and A.P. Butler, *Water Resources Research*, 44(7).
- Cho, J., J. Wilson, and F. Beck (2000), Measuring Vertical Profiles of Hydraulic Conductivity with In Situ Direct Push Methods, *Journal of Environmental Engineering*, 126(8), 775-777.
- Crowley, R. W., D. Bloomquist, and M. Rodgers (2013), Development of a Smear-Proof Horizontal and Vertical Permeability Probe, Florida Department of Transportation, Tallahassee, FL.
- Dietrich, P., J. Butler, and K. Faib (2008), A Rapid Method for Hydraulic Profiling in Unconsolidated Formations, *Groundwater*, 46(2), 323-328.
- FDOT (2021), *Soils and Foundation Handbook*. Florida Department of Transportation, State Materials Office. Gainesville, FL.
- Mohseni, A. and Crowley, R. FDOT (2016), Determination of Mean Permeability in the Field Using the Vertical Insitu Permeameter (VIP), Florida Department of Transportation, Tallahassee, FL.
- Hinsby, K., P. Bjerg, L. Andersen, B. Skov, and E. Clausen (1992), A Mini Slug Test Method for Determination of Local Hydraulic Conductivity of an Unconfined Sandy Aquifer, *Journal of Hydrology*, 136(1-4), 87-106.
- Hvorslev, M. (1951), Time Lag and Soil Permeability in Groundwater Observations, edited by U. A. C. o. Engineers, Vicksburg, MS.
- Klammler, H., K. Hatfield, B. Nemer, and S. Athias (2011), A Trigonometric Interpolation Approach to Mixed-Type Boundary Problems Associated with Permeameter Shape Factors, *Water Resources Research*, 47(3).

- Liu, G., G. Bohling, and J. Butler (2008), Simulation Assessment of the Direct-Push Permeameter for Characterizing Vertical Variations in Hydraulic Conductivity, *Water Resources Research*, 44(2), W06430.
- Liu, G., J. Butler, E. Reboulet, and S. Knobbe (2012), Hydraulic Conductivity Profiling with Direct Push Methods, *Groundwater*, 17(1), 19-29.
- Liu, G., J. Butler, G. Bohling, E. Reboulet, S. Knobbe, and D. Hyndman (2009), A New Method for High-Resolution Characterization of Hydraulic Conductivity, *Water Resources Research*, 45(8), W06430.
- Mathias, S., and J. Butler (2007), Shape Factors for Constant Head Double-Packer Permeameters, *Water Resources Research*, 43(6), W06430.
- Ratnam, S., K. Soga, and R. Whittle (2001), Revisiting Hvorslev's Intake Factors Using the Finite Element Method, *Geotechnique*, 51(7), 641-645.
- Rehbinder, G. (2005), Relation Between Non-Steady Supply Pressure and Flux for a Double Packer Conductivity Meter: An Approximate Analytical Solution, *Flow, Turbulence, and Combustion*, 74(1), 1-20.
- Reynolds, W., and J. Lewis (2012), A Drive Point Application of the Guelph Permeameter Method for Coarse-Textured Soils, *Geoderma*, 187-188(October), 59-66.
- Silvestri, V., G. Abou-Sarma, C. Bravo-Jonard. 2012. Shape factors of cylindrical piezometers in uniform soil. *Ground Water*, 50(2), 279-284.
- Terzaghi, K., and Peck, R. B., 1967. *Soil Mechanics in Engineering Practice*, 2nd ed. John Wiley and Sons, New York.

Zschornack, L., G. Bohling, J. Butler, and P. Dietrich (2013), Hydraulic Profiling with the Direct-Push Permeameter: Assessment of Probe Configuration and Analysis Methodology, *Journal of Hydrology*, 496 (July), 195-204.