

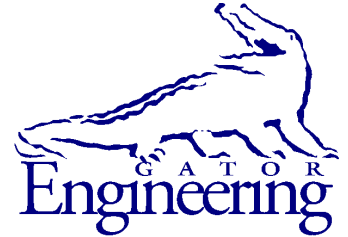

University of Florida
Civil and Coastal Engineering



University of Florida
Civil and Coastal Engineering

Final Report

October 2016

Sunshine Skyway Bridge Monitoring Phase I: System Assessment and Integration Recommendations

Principal investigator:

Jennifer A. Rice, Ph.D.

Co-Principal investigator:

Justin R. Davis, Ph.D.

Department of Civil and Coastal Engineering
University of Florida
P.O. Box 116580
Gainesville, Florida 32611

Sponsor:

Florida Department of Transportation (FDOT)
District 7 Structures Maintenance Office
Marshall T. Hampton, CBI, P.E. – Project Manager

Contract:

FDOT Contract No. BDV31-977-43

Disclaimer

The opinions, findings, and conclusions expressed in this publication are those of the authors and not necessarily those of the State of Florida Department of Transportation.

SI* (MODERN METRIC) CONVERSION FACTORS
APPROXIMATE CONVERSIONS TO SI UNITS

| SYMBOL | WHEN YOU KNOW | MULTIPLY BY | TO FIND | SYMBOL |
|--|------------------------|-------------------------|------------------------|-------------------|
| LENGTH | | | | |
| in | inches | 25.4 | millimeters | mm |
| ft | feet | 0.305 | meters | m |
| yd | yards | 0.914 | meters | m |
| mi | miles | 1.61 | kilometers | km |
| AREA | | | | |
| in² | square inches | 645.2 | square millimeters | mm ² |
| ft² | square feet | 0.093 | square meters | m ² |
| yd² | square yard | 0.836 | square meters | m ² |
| ac | acres | 0.405 | hectares | ha |
| mi² | square miles | 2.59 | square kilometers | km ² |
| VOLUME | | | | |
| fl oz | fluid ounces | 29.57 | milliliters | mL |
| gal | gallons | 3.785 | liters | L |
| ft³ | cubic feet | 0.028 | cubic meters | m ³ |
| yd³ | cubic yards | 0.765 | cubic meters | m ³ |
| NOTE: volumes greater than 1000 L shall be shown in m ³ | | | | |
| MASS | | | | |
| oz | ounces | 28.35 | grams | g |
| lb | pounds | 0.454 | kilograms | kg |
| T | short tons (2000 lb) | 0.907 | megagrams | Mg (or "t") |
| TEMPERATURE (exact degrees) | | | | |
| °F | Fahrenheit | 5(F-32)/9 or (F-32)/1.8 | Celsius | °C |
| ILLUMINATION | | | | |
| fc | foot-candles | 10.76 | lux | lx |
| fl | foot-Lamberts | 3.426 | candela/m ² | cd/m ² |
| FORCE and PRESSURE or STRESS | | | | |
| kip | 1000 pound force | 4.45 | kilonewtons | kN |
| lbf | pound force | 4.45 | newtons | N |
| lbf/in² | pound force per square | 6.89 | kilopascals | kPa |

*SI is the symbol for the International System of Units. Appropriate rounding should be made to comply with Section 4 of ASTM E380.

SI* (MODERN METRIC) CONVERSION FACTORS
APPROXIMATE CONVERSIONS FROM SI UNITS

| SYMBOL | WHEN YOU KNOW | MULTIPLY BY | TO FIND | SYMBOL |
|-------------------------------------|-----------------------------|-------------|-----------------------------|---------------------|
| LENGTH | | | | |
| mm | millimeters | 0.039 | inches | in |
| m | meters | 3.28 | feet | ft |
| m | meters | 1.09 | yards | yd |
| km | kilometers | 0.621 | miles | mi |
| AREA | | | | |
| mm² | square millimeters | 0.0016 | square inches | in ² |
| m² | square meters | 10.764 | square feet | ft ² |
| m² | square meters | 1.195 | square yards | yd ² |
| ha | hectares | 2.47 | acres | ac |
| km² | square kilometers | 0.386 | square miles | mi ² |
| VOLUME | | | | |
| mL | milliliters | 0.034 | fluid ounces | fl oz |
| L | liters | 0.264 | gallons | gal |
| m³ | cubic meters | 35.314 | cubic feet | ft ³ |
| m³ | cubic meters | 1.307 | cubic yards | yd ³ |
| MASS | | | | |
| g | grams | 0.035 | ounces | oz |
| kg | kilograms | 2.202 | pounds | lb |
| Mg (or "t") | megagrams (or "metric ton") | 1.103 | short tons (2000 lb) | T |
| TEMPERATURE (exact degrees) | | | | |
| °C | Celsius | 1.8C+32 | Fahrenheit | °F |
| ILLUMINATION | | | | |
| lx | lux | 0.0929 | foot-candles | fc |
| cd/m² | candela/m ² | 0.2919 | foot-Lamberts | fl |
| FORCE and PRESSURE or STRESS | | | | |
| kN | kilonewtons | 0.225 | 1000 pound force | kip |
| N | newtons | 0.225 | pound force | lbf |
| kPa | kilopascals | 0.145 | pound force per square inch | lbf/in ² |

*SI is the symbol for the International System of Units. Appropriate rounding should be made to comply with Section 4 of ASTM E380.

Technical Report Documentation Page

| | | | |
|--|---|---|-----------|
| 1. Report No. | 2. Government Accession No. | 3. Recipient's Catalog No. | |
| 4. Title and Subtitle Sunshine Skyway Bridge Monitoring Phase I: System Assessment And Integration Recommendations | | 5. Report Date October 2016 | |
| | | 6. Performing Organization Code | |
| 7. Author(s) Jennifer A. Rice, Ph.D., Justin R. Davis, Ph.D. | | 8. Performing Organization Report No. | |
| 9. Performing Organization Name and Address University of Florida Engineering School of Sustainable Infrastructure & Environment University of Florida 365 Weil Hall / PO Box 116550 Gainesville, FL 32611 | | 10. Work Unit No. (TRAIS) | |
| | | 11. Contract or Grant No. BDV31-977-43 | |
| 12. Sponsoring Agency Name and Address Florida Department of Transportation 605 Suwannee Street, MS 30 Tallahassee, FL 32399-0450 | | 13. Type of Report and Period Covered Draft Final Report 6/15/2015 – 10/31/2016 | |
| | | 14. Sponsoring Agency Code | |
| 15. Supplementary Notes | | | |
| 16. Abstract <p>The Sunshine Skyway Bridge has several different types of monitoring instruments in place maintained by Florida Department of Transportation (FDOT) offices, divisions, and partners. The current decentralized approach to data collection and monitoring on the bridge has resulted in a number of inefficiencies in the methods by which equipment is maintained and observational data is obtained. Although the safety of day-to-day bridge operations is not being compromised, the existing inefficiencies and challenges could be mitigated by a more robust, holistic monitoring system design, which would also support system expansion to accommodate additional sensors and more sophisticated monitoring approaches. The long-term research goal is to take the system from its current limited functionality to a fully integrated and highly flexible monitoring system with a user-friendly Web interface and full data archiving. This proposed system will combine data from existing sensors (weather stations, GNSS/GPS, accelerometers, etc.) into a single monitoring interface for data visualization and alerts. To leverage the data produced by the integrated monitoring system, a calibrated finite element model will be developed for use in setting loading and response thresholds for warning and maintenance decisions. The first step in achieving these goals is to understand the challenges and limitations of the existing monitoring system. As such, the larger research effort is divided into phases, and this report describes Phase I, in which the observations and recommendations in achieving the project's goals have been summarized.</p> | | | |
| 17. Key Word Cable-stayed bridge, structural health monitoring, bridge management, sensors, data acquisition. | | 18. Distribution Statement No restrictions. | |
| 19. Security Classif. (of this report) Unclassified | 20. Security Classif. (of this page) Unclassified | 21. No. of Pages 75 | 22. Price |

Acknowledgments

The authors thankfully acknowledge the support of this research by the Florida Department of Transportation (FDOT).

Executive Summary

Completed in April 1987, the Sunshine Skyway Bridge has average daily traffic of over 50,000 vehicles. Monitoring of the bridge movement is specified in the extensive maintenance manual provided by the bridge designers, Figg and Mueller. There have been a wide range of past monitoring efforts; however, there is not currently a fully functioning monitoring system that integrates data from various sensing systems into a single comprehensive view capable of providing routine or emergency condition assessment of the bridge. The primary roadblock has been the ad hoc approach to the implementation of monitoring hardware without consistent support from a single FDOT office. In addition to in situ monitoring, a MIDAS finite element (FE) model of the bridge was created to estimate the response (motion) of the bridge under severe wind loads. However, the model has not yet been fully calibrated with measured data, limiting its ability to provide accurate response predictions.

The long-term research goal is to take the system from its current limited functionality to a fully integrated and highly flexible monitoring system with a user-friendly Web interface and full data archiving. This proposed system will combine data from existing sensors (weather stations, GNSS/GPS, accelerometers, etc.) into a single monitoring interface for data visualization and alerts. To establish normal bridge response limits, data from the system will be collected and analyzed over a period of time that is adequate to capture diurnal and seasonal variations in response to a range of wind and traffic loading conditions. To fully leverage the data produced by the integrated monitoring system, an updated, calibrated FE model will be developed for use in setting loading and response thresholds for warning and maintenance decisions.

The first step in achieving the project goals is to understand the challenges and limitations of the existing monitoring system. As such, the larger research effort is divided into phases, and this report describes Phase I with the objectives: (1) identify and assess the condition and challenges of the existing monitoring hardware currently (or soon-to-be) installed on the Sunshine Skyway Bridge by the FDOT and other organizations, (2) engage stakeholders to determine the intent of the currently installed hardware and the desired features of an upgraded system, and (3) investigate effective methods for collecting, processing, storing, and visualizing data from the bridge, including the integration of advanced data management and bridge modeling techniques. This report presents the outcome of Phase I with a comprehensive set of recommendations for upgrading the Sunshine Skyway Bridge monitoring system to achieve the long-term goals of the research and meet the ongoing needs of the FDOT District 7 Maintenance Office. These recommendations include the consolidation of existing sensor subsystems, the connection of all data acquisition systems to the Skyway fiber network, the development of data processing methods and event alert thresholds to provide bridge management decision support, and the development of an integrated Web-based data visualization interface for the Skyway monitoring system.

Table of Contents

| | |
|---|------|
| Disclaimer | ii |
| Technical Report Documentation Page..... | v |
| Acknowledgments..... | vi |
| Executive Summary | vii |
| List of Figures..... | x |
| List of Tables | xii |
| List of Abbreviations | xiii |
| 1 Introduction..... | 1 |
| 1.1 Project Overview | 1 |
| 1.2 Skyway Monitoring System Stakeholders..... | 2 |
| 1.3 Brief Survey of Bridge Monitoring Systems | 3 |
| 1.4 Existing Skyway Monitoring System Overview | 7 |
| 1.5 Desired Features of the Skyway Monitoring System | 8 |
| 1.6 Naming Conventions and Layout..... | 8 |
| 1.7 Report Overview | 9 |
| 2 Inventory Database and Interactive Map | 10 |
| 2.1 Photo and Datasheet Repositories | 10 |
| 2.2 Descriptive Inventory Database..... | 10 |
| 2.3 Interactive Map..... | 10 |
| 3 Existing Installed Hardware..... | 13 |
| 3.1 Intelligent Transportation System | 13 |
| 3.1.1 Microwave Vehicle Detection System..... | 14 |
| 3.1.2 Cameras..... | 15 |
| 3.1.3 Visibility Sensors | 15 |
| 3.1.4 Weather Station..... | 16 |
| 3.1.5 Data Transport..... | 16 |
| 3.2 Surveying and Mapping Office | 17 |
| 3.2.1 GNSS Antennae/Receivers | 18 |
| 3.2.2 Automatic Motorized Total Stations | 19 |
| 3.2.3 Data Transport..... | 21 |
| 3.2.4 Summary | 23 |
| 3.3 State Materials Office..... | 23 |
| 3.3.1 Weather Station Located at the Center of the Main Channel Span..... | 24 |
| 3.3.2 Weather Station and Cameras Located at the North Tower | 24 |
| 3.3.3 Power and Data Transport..... | 26 |
| 3.3.4 Summary | 30 |
| 3.4 FDOT District 7 Maintenance Office | 30 |
| 4 Data Management..... | 33 |
| 4.1 Monitoring Data Types..... | 33 |
| 4.2 Data Storage | 35 |
| 4.2.1 Skyway Data Storage Requirements | 35 |
| 4.2.2 Data Storage Options | 36 |
| 4.3 Web Portal..... | 37 |
| 4.4 Data Management Options Summary..... | 38 |
| 5 Data Processing for Decision Support..... | 40 |
| 5.1 Routine Monitoring | 40 |
| 5.2 Critical Event Monitoring..... | 41 |
| 6 Finite Element Model Assessment | 43 |
| 7 Skyway Monitoring System Recommendations..... | 45 |

| | | |
|-------|--|----|
| 7.1 | Monitoring Hardware | 45 |
| 7.1.1 | Bridge Movement Measurement | 45 |
| 7.1.2 | Bridge Environment Measurement | 48 |
| 7.1.3 | Data Acquisition..... | 49 |
| 7.2 | Data Access and Web Interface..... | 49 |
| 7.3 | Inventory Database and Interactive Map..... | 51 |
| 8 | Monitoring System Implementation | 52 |
| 9 | Conclusions | 54 |
| | References..... | 55 |
| | Appendix: A User’s Guide to Editing the Inventory Database and Interactive Web Map | 56 |
| A1 | Editing the Interactive Map | 56 |
| A1.1 | Establishing Points to Place Markers | 56 |
| A1.2 | Adding Markers through JavaScript Code | 57 |
| A1.3 | Adding Polylines through JavaScript Code..... | 60 |
| A2 | Editing the Excel Inventory | 60 |
| A2.1 | Excel Sheet Organization | 61 |
| A2.2 | Office and Points of Interest Tabs | 61 |
| A2.3 | Datasheets Tab..... | 61 |

List of Figures

| | |
|--|----|
| Figure 1-1. Layout of the wireless sensor nodes on the Jindo Bridge. | 6 |
| Figure 1-2. Sensor placement on either side of the box-girder deck (yellow dots). | 6 |
| Figure 2-1. The entire domain of the Sunshine Skyway Bridge map. | 11 |
| Figure 2-2. The South Tower of the Sunshine Skyway Bridge with the location of the GNSS receiver highlighted. | 11 |
| Figure 3-1. An ITS-installed maintenance cabinet located at the center of the main channel span. | 14 |
| Figure 3-2. The MVDS sensor located at MM 10.6. | 14 |
| Figure 3-3. (a) Traffic camera on the North Tower over the northbound traffic lane, (b) thermal imaging camera on the North Tower, and (c) other camera on the South Tower. | 15 |
| Figure 3-4. The visibility sensor located at MM 10.9. | 15 |
| Figure 3-5. (a) ITS weather station at the center of the main span, (b) ultrasonic anemometer, and (c) relative humidity and temperature sensor. | 16 |
| Figure 3-6. (a) ITS cabinet at the base of the South Tower, (b) RUGGEDCOM network switch, and (c) fiber optic patch panel (LIU). | 17 |
| Figure 3-7. Location of GPS antennae. | 18 |
| Figure 3-8. GNSS antennae: south end of the main span (left) and center of the main channel span (right). | 18 |
| Figure 3-9. GNSS receivers: GR10 (left) and GRX1200 (right). | 19 |
| Figure 3-10. Former AMTS and current prism locations, plan (above) and elevation (below). | 20 |
| Figure 3-11. Former TM30 AMTS on Dolphin 104 with solar power (left) and close-up (right). | 20 |
| Figure 3-12. Prism on the North Tower. | 21 |
| Figure 3-13. Connection diagram of the maintenance cabinet at the base of the North Tower. | 22 |
| Figure 3-14. AMTS Wi-Fi receivers on the North Tower (left) and South Tower (right). | 22 |
| Figure 3-15. (a) Weather station, (b) integrated weather sensor, (c) embedded concrete thermocouples, and (d) interior of the EDS data acquisition and communication box. | 24 |
| Figure 3-16. Northbound camera on the North Tower. | 25 |
| Figure 3-17. North Tower thermocouples. | 25 |
| Figure 3-18. North Tower integrated weather station (left) and EDS data acquisition box (right). | 26 |
| Figure 3-19. Connection diagram for the weather station, thermocouples, and EDS data acquisition box located at the center of the main channel span. | 27 |
| Figure 3-20. Digi XCite RF Modem (left) and DigiXStream RF Modem (right). | 27 |
| Figure 3-21. Connection diagram for the north weather station, thermocouples, camera, and EDS data acquisition box. | 28 |
| Figure 3-22. Davis Vantage Pro2 weather station sensor interface module. | 29 |
| Figure 3-23. Davis Vantage Pro2 weather station console. | 29 |
| Figure 3-24. (a) North Tower RF modem housing and (b) Cradlepoint cellular modem. | 29 |
| Figure 3-25. Locations of the tower and cable stay accelerometers and data acquisition cabinets. | 32 |
| Figure 4-1. Representative data management framework for monitoring data. | 33 |
| Figure 4-2. Example cable force estimation (bottom) from acceleration time history and frequency domain response calculations (top). (From BDI, Inc. http://bridgetest.com/products/sts-cfa-cable-force-measurement-software/). | 34 |
| Figure 6-1. (a) Damper struts on the Skyway cables, (b) cable stays without damper struts in the MIDAS model. | 44 |
| Figure 7-1. Existing and proposed GNSS antennae locations. | 47 |
| Figure 7-2 Proposed tiltmeter locations, shown with blue dots, on the South and North Towers (Pier 111 and 112). | 48 |
| Figure 7-3 Current and proposed deck and tower accelerometer locations. | 48 |
| Figure 7-4 Proposed accelerometer locations, shown with pink dots, within main span girder. | 48 |
| Figure 7-5 Recommended data access and interface. | 50 |

Figure A-1. Screen shot of “Mouse Click Event (draggable)” selection from the drop-down list (left) and screen shot of example resulting pop-up (right)..... 57

Figure A-2. Example JavaScript code for Cars Example 59

Figure A-3. Web map for the Cars Example 59

Figure A-4. Modifications to the Excel Inventory showing how the Car Example would be added..... 62

List of Tables

| | |
|---|----|
| Table 1-1. Skyway stakeholders | 2 |
| Table 1-2. Summary of some existing cable-stayed bridge SHM systems..... | 7 |
| Table 3-1. GPS antenna and receiver locations. ID refers to mile marker (101 = MM 10.1) followed by an A (anchor), T (tower), or M (median). Receivers are located inside ITS maintained cabinets. ... | 19 |
| Table 3-2. Lights and beacons. | 31 |
| Table 4-1. Data size estimates based on existing Skyway monitoring sensors..... | 36 |
| Table 4-2. Data storage and interface strategy comparison (UF = University of Florida, DSMO = District 7 Maintenance Office, AST = Agency for State Technology, and Cont. = non-UF contractor)..... | 39 |
| Table 5-1. Triggered Skyway monitoring events and responses. | 41 |
| Table 7-1. Bridge motion measurements. | 46 |

List of Abbreviations

| | |
|---------------|---|
| AMTS | Automatic Motorized Total Station |
| ASCII | American Standard Code for Information Interchange |
| AST | Agency for State Technology |
| BEMS | Bridge Environmental Monitoring System |
| BES | Bridge Engineering Solutions |
| BDI | Bridge Diagnostics, Inc. |
| BIM | Building Information Modeling |
| BrIM | Bridge Information Modeling |
| CEL | Cleveland Electric Laboratories |
| CPU | Central Processing Unit |
| DeIDOT | Delaware Department of Transportation |
| DOT | Department of Transportation |
| DSMO | District Structures Maintenance Office – District 7 |
| DSS | Decision Support System |
| EDS | Environmental Data Systems |
| EIS | Enterprise Infrastructure Services |
| FE | Finite Element |
| FDOT | Florida Department of Transportation |
| FHP | Florida Highway Patrol |
| FPRN | Florida Permanent Reference Network |
| GNSS | Global Navigation Satellite System |
| GPS | Global Positioning System |
| ITS | Intelligent Transportation Systems |
| LIU | Fiber optic patch panel |
| MVDS | Microwave Vehicle Detection System |
| NB | Northbound |
| NetCDF | Network Common Data Form |
| NOAA | National Ocean and Atmospheric Administration |
| OIT | Office of Information Technology |
| PDU | Power Distribution Unit |
| PVC | Polyvinyl Chloride |
| RF | Radio Frequency |
| SB | Southbound |
| SHM | Structural Health Monitoring |
| SIM | Sensor Interface Module |
| SMO | State Materials Office |
| TMC | Traffic Management Center |
| UD | University of Delaware |
| UF | University of Florida |
| UPS | Uninterruptible power supply |
| USB | Universal Serial Bus |
| VLAN | Virtual Local Area Network |
| VPN | Virtual Private Network |
| XML | Extensible Markup Language |

1 Introduction

1.1 Project Overview

The Sunshine Skyway Bridge, spanning the main entrance to Tampa Bay, is considered one of the flagship bridges in the State of Florida, with average daily traffic of over 50,000 vehicles. With an estimated replacement cost of \$2 billion, the bridge is expected to have a remaining life of over 70 years. Upon completion in April 1987, the bridge's designers, the Figg and Mueller, specified in the maintenance manual that movement of the bridge should be regularly monitored. Early in the life of the bridge, the FDOT conducted regular global navigation satellite system (GNSS) testing using GPS to track structural movement but found the process to be costly and complex with limited useful results. In the 1990s, the FDOT Surveying and Mapping Office installed five GPS receivers and established a website to enable continuous data monitoring. Later, an Automatic Motorized Total Station (AMTS) was installed on one of the main dolphins for scanning targets (prisms) located on the bridge piers and beneath the deck. In 2005, an additional AMTS was installed on a second main dolphin on the opposite side of the main span, and two weather stations were added at the locations of two of the GPS receivers. In 2011, the five original GPS receivers were upgraded. The original weather stations are currently operated and maintained by the FDOT State Materials Office and an additional weather station was installed and is operated by the FDOT Traffic Engineering and Operations Office, through its Intelligent Transportation Systems (ITS) Division. To assess the condition of the cable stays, the Maintenance office has conducted (through a contractor) cable stay tension testing every six years, and in the last year, a number of accelerometers were permanently installed on several stay cables to provide cable force data.

The overarching research goal of the project is to take the Sunshine Skyway Bridge monitoring system from its current limited functionality to a fully integrated and highly flexible monitoring system including a user-friendly Web interface and full data archiving. This envisioned system will combine data from the multiple sensors and sensor subsystems (weather stations, GNSS/GPS, accelerometers, etc.) into a single monitoring interface for data visualization and alerts. To leverage the data produced by the system, a finite element (FE) model will be developed and calibrated for use in setting loading and response thresholds for maintenance decisions and warnings. The first step in achieving this goal is to understand the challenges and limitations of the existing monitoring system. As such, the larger research effort is divided into phases, with the Phase I research project completed and reported herein.

The objectives of Phase I were to (1) identify and assess the condition and challenges of the existing monitoring hardware currently installed on the Sunshine Skyway Bridge (hereafter referred to as the Skyway) by the FDOT and other organizations, (2) engage stakeholders to determine the intent of the currently installed hardware and the desired features of an upgraded system, and (3) investigate effective methods for collecting, processing, storing, and visualizing data from the bridge, including the integration of advanced data management and bridge modeling techniques. The result of Phase I is a comprehensive set of recommendations for upgrading the Sunshine Skyway Bridge monitoring system to achieve the long-term goals of the research and meet the ongoing needs of the FDOT District 7 Structures Maintenance Office (DSMO).

The following tasks were carried out to achieve the Phase I research objective:

- **Task 1 - Initial System Assessment:** Overview and history of the Skyway monitoring system.
- **Task 2 - Hardware Evaluation:** In-depth, on-site evaluation of the existing sensing, communication, computing, and electrical hardware and the development of a comprehensive inventory database and interactive map.
- **Task 3 - Data Management, Access, and Integration:** Investigation of methods that provide decision support during routine bridge operation and following an extreme event.
- **Task 4 - System Design Recommendations:** Compilation and synthesis of information and results from Tasks 1-3 into a set of design recommendations.

This final report is a compilation of the findings reported in previous task reports.

1.2 Skyway Monitoring System Stakeholders

This report refers to several groups responsible for monitoring system development and Skyway decision support. These groups are collectively referred to as “stakeholders” and represent individuals and entities that have responsibility for, and an interest in, the safe and effective operation of the Skyway. Ultimately, all stakeholders will be provided access to the final Web-based monitoring system interface. Those also referred to as “developers” will have direct input on the development and maintenance of the monitoring system. As such, lower level access to the networks and raw data from the Skyway will be required by these individuals. Table 1-1 summarizes the stakeholders.

Table 1-1. Skyway stakeholders

| Stakeholder | Point of Contact | Location | Developer |
|---|----------------------------------|-------------------------------|------------------|
| District 7 Structures Maintenance Office (DSMO) | Marshall Hampton Steve Womble | Tampa, FL | Yes |
| State Materials Office (SMO) | Ivan Lasa | Gainesville, FL | No |
| Intelligent Transportation Systems (ITS) | Andrew Young Mark Mathes | SunGuide Center, Tampa, FL | Yes |
| Survey & Mapping District Office | Alex Parnes | Tampa, FL | Yes |
| Survey & Mapping State Office | Ron Hanson | Tallahassee, FL | Yes |
| University of Florida (UF) | Jennifer Rice | Gainesville, FL | Yes |
| Asset Maintenance Contractor (DBi/PB) | Rob Little | Tampa, FL | No |
| Monitoring System Contractor (BDI) | Jesse Sipple | Boulder, CO | Yes |

1.3 Brief Survey of Bridge Monitoring Systems

Structural health monitoring (SHM) has the potential to provide continuous, real-time data to assess the condition of a structure. As a result, many bridge owners are looking to SHM to supplement and enhance existing bridge inspection and management practices. The Oregon Department of Transportation is one example of a state Department of Transportation that has implemented bridge SHM as part of a bridge management strategy (Lovejoy and Myers, 2012). Their SHM program monitors the foundations, concrete superstructure, moveable bridge functionality, steel fatigue, structural dynamics, and corrosion protection (CP) systems. All 13 of the bridges in their monitoring program had previously identified structural concerns that warranted additional monitoring. In addition to the measurement of environmental conditions (temperature and humidity), tilt and soil pressure sensors are used to monitor foundations, crack displacement sensors are used to track crack widths in concrete superstructures and steel elements, and strain gauges are used to track stress cycles associated with steel fatigue. Structural vibrations are monitored to detect excessive amplitude displacements and vibrations that may lead to fatigue cracking in slender truss elements. The data from the monitoring systems are sent to the State Data Server, where authorized users may access the data remotely.

Vibration-based SHM is of particular interest in long span bridges or bridges with flexible elements, such as cables. These structures and components are susceptible to wind loading and excessive vibrations. Among other sensors, accelerometers are installed when monitoring these structures to capture the vibration and characterize bridge dynamics. A 2012 report provided by Bridge Engineering Solutions (BES) as part of Parsons Brinckerhoff, Inc. assessment of the Skyway (Mehrabi, 2012) provides some examples of bridges instrumented specifically for vibration-based assessment. Some of these examples represent short-term monitoring activities while others represent longer-term measurement campaigns. The BES report highlights that accelerometers alone may not provide a complete picture of structural motion, as they are not well-suited to the measurement of low frequency motions (less than 1 Hz). However, GPS receivers, used in conjunction with accelerometers, can mitigate this limitation by providing more accurate low frequency displacement measurements. This accelerometer/GPS data integration and fusion requires the use of advanced data processing, such as adaptive filtering, to take advantage of both sensor measurement types.

Many long-term SHM systems are implemented as a preventative measure, without previously identified damage to the structure. These preventative systems are often installed during the construction process. The following bridge SHM system overview, resulting from a literature search and personal communication, provides information on systems installed on cable-stayed and suspension bridges. This overview includes information about the types of sensors, systems, data analysis, and decision support that were implemented. For these systems, monitoring cables is of high importance for the detection of issues related to cable corrosion, fatigue, and excessive vibration; however, these systems also monitor environmental conditions to track wind- and climate-induced structural responses and driver safety conditions. The following paragraphs, focus on how the data is processed and what decisions, if any, have been based on the output of the SHM system. Table 1-2 summarizes these SHM systems and identifies systems that were installed only as part of a research study ('Research Only'), and not as part of a bridge management strategy overseen by the bridge owner.

Indian River Inlet Bridge (Delaware)

The Indian River Inlet Bridge in Delaware is a cable-stayed bridge with a 290-m main span and 122-m back spans. Two 75.6 m-high twin hollow box pylons support a total of 152 stays. The concrete bridge deck consists of two edge girders, transverse beams, and a cast-in-place deck. The bridge, completed in 2012, has an SHM system that was integrated during construction (Shenton et al., 2014, and J. Arndt, personal communication, Feb. 24, 2016).

The University of Delaware (UD) designed and currently maintains the SHM system under a four-year contract with the Delaware DOT (DeIDOT). The monitoring software is provided by Cleveland Electric Laboratories (CEL) under a separate contract with DeIDOT. The system consists of 70 embedded optical fiber strain and temperature sensors, 27 accelerometers, three displacement gauges, nine tiltmeters, two anemometers (wind speed and direction), and 16 chloride sensors. The strain sensors, embedded in the concrete during construction, are used to measure thermal effects, stay cable stress loss, post-tensioning loss, and loading effects. Load rating tests have been conducted and the results have been used to calibrate an FE model of the bridge. The accelerometers on the stays are used to estimate cable forces, while the deck and pylon accelerometers are used to conduct modal analysis (natural frequency, mode shape, and damping ratio estimation). The tilt and displacement sensors are used to track thermal displacements on bearing and expansion joints and estimate stiffness properties. The chloride sensors (installed in the concrete during construction) are used to determine the potential for corrosion. Because the system was installed during construction, conduit, cabling and block-outs were directly integrated into the structure.

Data is stored locally on the bridge on two PCs for redundancy, as well as at the state Transportation Management Center (TMC). Remote access to the data on the state network is provided to key personnel via a VPN connection. Data is collected continuously and reports are generated on a monthly and yearly basis. When pre-established thresholds are exceeded on certain sensors, text and email messages are sent to appropriate personnel. UD researchers and the DeIDOT Bridge Management Section developed the initial data thresholds for triggering higher frequency data collection and sending the warning messages; these triggers are being refined over the four-year project based on the collected data. Eventually, DeIDOT will take over full management of the monitoring system.

Humber Bridge (United Kingdom)

The Humber Bridge, a 2,200-m suspension bridge, is the longest span bridge in the United Kingdom and has been the subject of various monitoring programs since it was first instrumented in the 1980's. The purpose of its instrumentation was the validation of FE and wind response simulations. In total, 63 sensors were deployed on the bridge, including anemometers, accelerometers, and displacement sensors. The measured data was used to evaluate the aeroelastic properties of the bridge as well as the dependence of modal parameters on wind velocity levels. The researchers concluded that while global (whole structure) measurements provide information to validate modeling and simulation, they are not expected to detect damage in the structure. Thus, the researchers proposed that short-term, targeted testing would be more appropriate to monitor the critical components of the bridge (Brownjohn 2007).

Golden Gate Bridge (California)

The Golden Gate Bridge in San Francisco, CA is a suspension bridge with a 1280-m main span. It has been the subject of several monitoring efforts by researchers, although it does

not currently have a comprehensive SHM system in place. Abdel-Ghaffar and Scanlan (1985) conducted ambient vibration testing to determine natural frequencies, effective damping ratios, and mode shapes in an attempt to understand and predict the bridge's response to wind and earthquake loading. The bridge was instrumented with 28 accelerometers with 12 on the main span, 6 on the side spans, and 10 on the pier-tower structures. The measured data was analyzed, and the vibration modes were accurately identified when compared to theoretical calculations. More recently, the bridge was instrumented with 64 wireless sensors as a proof-of-concept for wireless SHM (Pakzad et al. 2008). The resulting measurements included 128 channels of acceleration data and 64 channels of temperature measurements sampled at 200 Hz. The data was used to perform modal analysis on the bridge which was compared to previously calculated results.

Bill Emerson Memorial Bridge (Missouri)

The Bill Emerson Memorial Bridge, which opened in 2003 in Cape Girardeau, Missouri, is a cable-stayed bridge with a total length of 1210 m and a main span of 350 m. The bridge was instrumented by researchers in an effort to provide seismic response data, validate FE models, and gain insight for future cable-stayed bridge designs (Caicedo et al. 2002, Çelebi 2006). The long-term monitoring system was intended to provide real-time response data via the internet for wide dissemination. Eighty-four accelerometer channels were installed on the bridge, in addition to anemometers to measure wind velocities. The data from this monitoring project has been used for a variety of purposes, ranging from the evaluation of damage detection algorithms to seismic response evaluation and FE model updating/calibrating techniques. The total cost of the monitoring system was ~\$1.5M (in 2005), which is about 1 to 1.5% of the construction budget. The monitoring activities on the bridge have been conducted by partnerships between university researchers and the Missouri DOT (Hartnagel et al. 2006).

Tsing Ma Bridge (Hong Kong)

The Tsing Ma Bridge is a suspension bridge in Hong Kong. An integrated monitoring system has been installed on the bridge at the request of the bridge owner that consists of a variety of sensors and data acquisition, as well as data processing, and SHM systems (Wong 2004). The sensor system includes acceleration, displacement, strain, wind, and temperature measurements, as well as video cameras and GPS measurement stations, for a total of 326 data channels. This extensive monitoring system is intended for a variety of purposes related to SHM, including: 1) measuring loading sources, 2) determining system characteristics (e.g., global dynamic properties), and 3) measuring the system response (e.g., cable forces and fatigue assessment). The response of the bridge due to various loading conditions is recorded and any observed abnormalities in the response are expected to alert key personnel of potential overloading.

Jindo Bridge (South Korea)

The Jindo Bridge is made up of twin cable-stayed bridges that connect Jindo Island to the far southwestern tip of the Korean Peninsula near the town of Haenam. The older span finished construction in 1984 and the newer span was completed in 2005. The BES report (Mehrabi 2012) describes the monitoring that was conducted on the older span (the Jindo Grand Bridge).

In 2009, a comprehensive wireless sensor network system for vibration and environmental monitoring was installed on the newer span, which is 484 m in total length, with a

main span of 344 m. The SHM system was installed for research purposes, to demonstrate a prototype wireless smart sensor network and validate the autonomous network software (Jang et al. 2010, and Rice et al. 2010). Each wireless sensor node was solar powered with its own microprocessor and radio and supported multiple data channels. A total of 113 wireless sensor nodes resulted in 330 channels of acceleration measurements, nine channels of wind measurements, and 113 channels each of temperature, light and humidity measurements. The 330 acceleration channels measured three axes of acceleration on each of the stay cables, along both sides of the underside of the main steel box girder, and at three locations on each of the pylons, as shown in Figure 1-1 and Figure 1-2.

The new Jindo Bridge monitoring system took advantage of the microprocessors that each of the wireless sensors possessed to do much of the data processing at the sensor locations, prior to sending the processed results to one of two base stations located on the bridge (one on each tower). This in-network data processing included cable tension estimation and dynamic analysis of the bridge (natural frequencies, mode shapes and damping ratios), without having to communicate large amounts of raw data wirelessly. Once the pre-processed data was sent to the base stations, the data was stored locally on PCs and accessed via a cable modem by researchers in the U.S., Japan, and Korea. The SHM network operated autonomously, collecting data on a set schedule, unless triggered by the exceedance of predetermined threshold values. Both vibration and wind level thresholds were set so that data could be collected under higher than usual loading conditions. The data was also used to calibrate an FE model of the bridge.

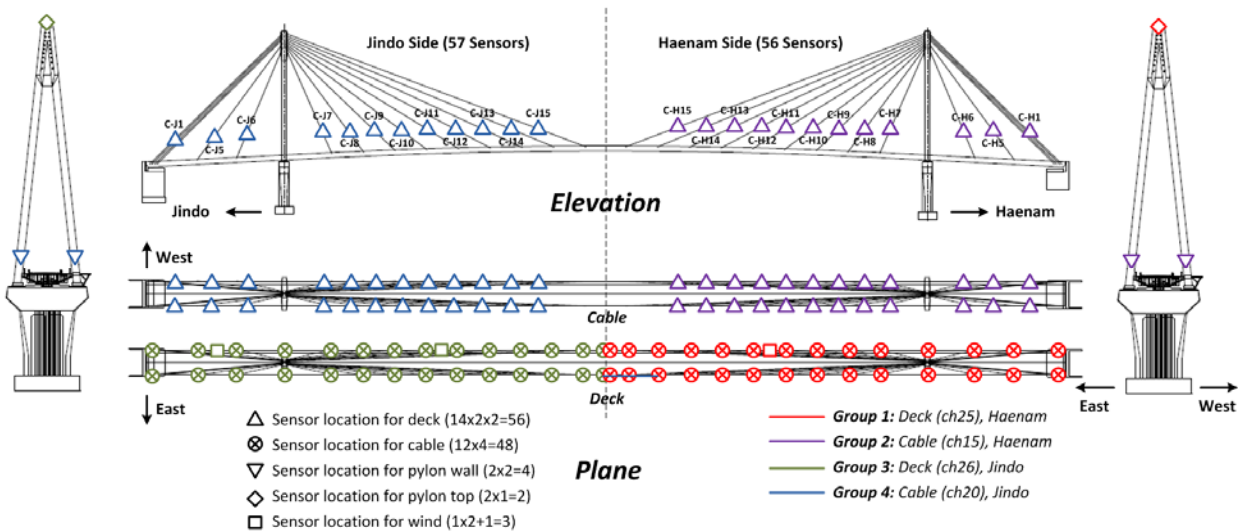

Figure 1-1. Layout of the wireless sensor nodes on the Jindo Bridge.

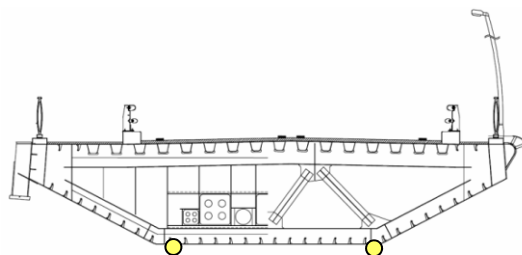

Figure 1-2. Sensor placement on either side of the box-girder deck (yellow dots).

Table 1-2. Summary of some existing cable-stayed bridge SHM systems.

| Bridge | Research Only | Modal Analysis | Load Rating | Cable Tension Estimation | Wind/Temp. Monitoring | FE Model Calibration |
|----------------------------------|----------------------|-----------------------|--------------------|---------------------------------|------------------------------|-----------------------------|
| Indian River Inlet (Delaware) | | • | • | • | • | • |
| Humber (United Kingdom) | • | • | | | • | • |
| Golden Gate (California) | • | • | | | • | • |
| Bill Emerson Memorial (Missouri) | | • | | • | • | • |
| Tsing Ma (Hong Kong) | | • | • | • | • | • |
| Jindo (New Span) (South Korea) | • | • | | • | • | • |

1.4 Existing Skyway Monitoring System Overview

The four FDOT offices that currently maintain monitoring equipment or have plans for future equipment installation on the Skyway Bridge are: the State Materials Office (SMO), the Intelligent Traffic Systems (ITS) Division of the Traffic and Engineering Operations Office, the District 7 Maintenance Office, and the Surveying and Mapping Division of the Design Office. While the specific goals of each office vary, the overall theme is to maintain the safety of the thousands of travelers who cross the bridge daily, both now and through the remaining life of the bridge. Each of the systems operated by the different offices are essentially independent, though they share some power and communication resources. As such, the maintenance of each system's hardware and data is, in some cases, provided by each office individually and, in other cases, provided with assistance from another office. As a result, the reliability of each system is quite different; some systems are fully capable of providing real-time data 24/7, while other systems have inoperable communications requiring periodic on-site data downloading. Although there is redundancy to some of the monitoring that is occurring (e.g., weather data and cameras), not all of the different data sources are readily available to all the FDOT users. In some cases, there may even be electromagnetic interference between the individual systems. The overall result is a sub-optimal, loosely coordinated approach to monitoring the bridge.

In addition to in-situ monitoring, a MIDAS FE model of the bridge has been created. The model has been used to estimate the response (motion) of the bridge under severe wind loads. However, the model has not yet been fully calibrated with measured data, limiting its ability to

provide accurate response predictions. This project investigated the state of the current model to make recommendations on its calibration and integration into an upgraded monitoring system.

1.5 Desired Features of the Skyway Monitoring System

The following list summarizes the basic desired features of an upgraded and integrated monitoring system. This list reflects some of the features that are required to overcome the existing challenges with the current monitoring systems.

- Hardware
 - Reliable power sources
 - Sufficient surge protection
 - Reliable communications
- Data
 - Web access
 - Real-time access
 - Data integration
 - Scalable interfaces
- Cost
 - Use existing experienced personnel/contractors
 - Leverage existing communication/power resources
 - Minimize maintenance
- Maintenance
 - Well-documented, including a maintenance handbook
 - Off-the-shelf components
 - Integrated system monitoring/troubleshooting
 - Planned component life cycles

1.6 Naming Conventions and Layout

While reviewing the bridge documentation produced by different offices and contractors, some inconsistencies were identified in the labeling conventions used for components on the bridge (e.g., cable stays). To ensure clarity and continuity of this report, the inventory map, and the database, consistent labeling and naming conventions have been adopted in consultation with FDOT personnel.

The piers are labeled according to two different references. First, in accordance with FDOT standard practice, the piers are numbered sequentially from south end of the bridge to the north end of the bridge. Second, in accordance with frequent design practice, the piers are numbered relative to the tower to which they are closest. For example, the North Tower is the 112th pier from the south end of the bridge so it is known as Pier 112 or 1N. The next pier to its north is Pier 113 or 2N, the second next pier to its north is Pier 114 or 3N, and so on. In a similar fashion, the South Tower is Pier 111 or 1S, the next pier to the south is Pier 110 or 2S, the second next pier to the south is Pier 109 or 3S, and so on.

Similar to the north/south labeling of the piers, the cable stays and their lights are referenced by their position from the towers. For example, the furthest north cable stay (north of

the North Tower) is referred to as 112-21N, the next to the south is 112-20N, and so on until the first cable stay to the north of the North Tower, which is referred to as 112-1N. Similarly, the first cable stay to the south of the North Tower is 112-1S, the second 112-2S and so on until the last cable stay attached to the North Tower, 112-21S. This pattern repeats for the cable stays associated with the South Tower.

To further help identify the locations of items present on the bridge, the “mile marker” (MM) system is also used. These markers appear in various places on the bridge on the northbound side, the southbound side, in the median, or inside the main bridge girders. These numbers are marked by either their own free standing signs or on the sides of cabinets. All of the visible markers between MM 6.5 and MM 13.5 were recorded and can be seen in several of the figures which follow later in this report.

Overall, there are three general regions of interest on the main span: the northern end of the main span, the main channel span, and the southern end of the main span. The northern end of the main span extends from Pier 117 (6N) (transition pier to northern high level approach) to Pier 112 (1N) (North Tower). The main channel span is the region between the North and South Towers. The southern end of the main span extends from Pier 111 (1S) (South Tower) to Pier 107 (6S) (transition pier to the southern high level approach).

1.7 Report Overview

Subsequent sections of this report are organized as follows: Section 2 provides an overview of an inventory database and an interactive map prepared to facilitate the creation and future maintenance of a comprehensive bridge monitoring system hardware inventory. The database, in the form of an excel spreadsheet, and the Web-based map are intended to be easily expandable by the DSMO as additional monitoring systems and functionalities are added to the bridge. Section 3 describes the components and functionality of the existing installed hardware on the bridge, categorized by the office responsible for its installation and maintenance. Several hardware and monitoring systems that are not currently installed but are planned for future installation are also described. An effective monitoring system must generate information that can be assessed quickly, to support decision making during routine bridge operation and following an extreme event. Sections 4 and 5 investigate methods to support this functionality. An overview of data management strategies in Section 4 is followed by data storage and visualization options available for the Skyway monitoring system. Section 5 discusses how data can be used in a decision support framework for routine and extreme event monitoring and Section 6 presents an evaluation of the existing MIDAS FE model of the Skyway and assesses its suitability for integration with the Skyway monitoring system. Section 7 of this report provides a comprehensive list of recommendations for upgrading the Sunshine Skyway Bridge monitoring system. Section 8 outlines a recommended process for implementing the proposed monitoring system in a Phase II project. Conclusions are given in Section 9.

2 Inventory Database and Interactive Map

A comprehensive database and corresponding interactive map have been created to inventory equipment and monitoring hardware currently installed on the bridge. In both the database (excel spreadsheet) and map, the items are divided into categories based on the office responsible for their installation and maintenance. Recommendations on expansion and maintenance of the inventory database and interactive Web map are provided in Section 7.3 and an editing guide is provided in the Appendix.

2.1 *Photo and Datasheet Repositories*

Photos taken of different items on the bridge, as well as datasheets, manuals, and other documentation, have been placed into a repository. In general, the file names are some combination of the date/time the picture was taken and a description of the file. Items placed in these repositories are linked directly from both the database and the interactive map.

2.2 *Descriptive Inventory Database*

A database of items present on the bridge or general points of interest has been developed in an excel spreadsheet. This spreadsheet is organized by tabs based on the office responsible for the equipment. Within the database, there are descriptions of items (type, model number, etc.) and their location, along with the name of a photo and datasheet present in the repository when available. In addition, a “link” is also provided which enables a repository item to be opened with a mouse click. Information present in the database is then used to populate the interactive map.

2.3 *Interactive Map*

With different components of the Skyway Bridge identified and cataloged in the spreadsheet, a Web browser-based interactive map was created. The map is designed to give the user the ability to both see the relative positions of components in a spatial sense (markers which mark positions on a base map layer) as well as to provide information about the individual components, including descriptions and close-up photos (pop-ups which open up when markers are clicked). While the map application is browser-based, it does not require a network connection. As long as the necessary files are accessible to a Web browser (e.g., on a local hard drive or a file share), the map can be accessed. If desired, the map application could be placed on a private (intranet) or public-facing (internet) Web server. The map has been designed to work across varying browser types and on mobile devices. Figure 2-1 shows a zoomed out view of the plan view of the Skyway Bridge provided by the map. Figure 2-2 shows an example of the screen that displays when a single component (in this case the GNSS receiver located on the South Tower) is clicked and zoomed in on.



Figure 2-1. The entire domain of the Sunshine Skyway Bridge map.

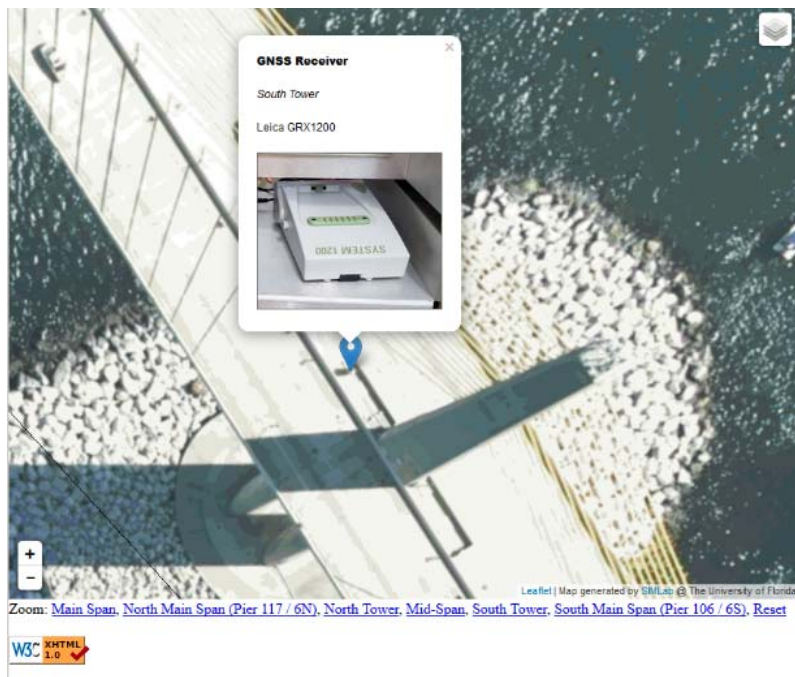

Figure 2-2. The South Tower of the Sunshine Skyway Bridge with the location of the GNSS receiver highlighted.

Rather than using a heavy, complex software application to build the map (e.g., ESRI GIS Software), it was built entirely with simple HTML, JavaScript, and Leaflet, an open-source JavaScript library for making interactive maps. At the lowest level, features which appear on the map are supplied using GeoJSON, an open standard format for representing simple geographical features (points, lines, polygons, etc.). To simplify things even further, all items which appear

on the map were designed to have both their markers and pop-ups be displayed in a similar manner such that a very simple syntax could be used (map-specific pixel coordinates, location description, component description, image1, image2) in the code to add items to the map.

The base layer of the map is derived from an overhead photo provided by the FDOT. In this photo, a series of aerial photos were stitched together to form a single 99,303x110,950-pixel, 344MB PNG file, as illustrated in Figure 2-1. Two flight paths were used to take the individual photos. The first flight path (approximately MM 6.5 to MM 9.5) was oriented from SE-NW and had a centerline slightly to the east of the bridge. The second flight path (MM 8.5 – MM 13.5) was oriented from SSE-NNW and had a centerline which varied from west of the bridge to directly over the bridge for a very short distance near the north rest area. As a result of the centerline of the flight paths not being directly over the bridge, it is extremely difficult to use the photo in any sort of geo-referenced sense because nearly all of the photos capture the bridge at an angle and this angle varies along the length of the bridge depending on how close, or how far the centerline of the flight path was, from the bridge. As such, rather than using latitude or longitude as coordinates, simple pixel-based map coordinates are used on the map. These coordinates range from [0,0] in the upper left to [99,303,110,950] in the lower right, where an increasing x-coordinate means heading to the east, while an increasing y-coordinate means heading to the south.

When using a single 344MB image file as a base layer, it is impractical to quickly render on a computer screen even with the most modern computing hardware. Thus, this image was tiled into 10 different zoom levels using a version of gdal2tiles designed specifically for use with Leaflet (<https://github.com/commenthol/gdal2tiles-leaflet>). Tiling is the process by which images can be effectively coarsened for the purpose of viewing at a low zoom level when an overview of the whole domain is required. At higher zoom levels, when only a small portion of the image would be on the screen, the full resolution of the image is used. The overall effect results in a map which requires the minimum amount of on-screen rendering effort and allows for very rapid display and navigation around the map. A more thorough explanation of how tiling is used in Web mapping can be found here: <https://www.mapbox.com/help/how-Web-maps-work/>

The map is drawn in a browser window using Leaflet (<http://leafletjs.com>). Leaflet handles coordinate systems, zooming, pop-ups, etc. using a very simple application interface (API). The map consists of a base layer and selectable overlays which appear on top of the base layer. To remain consistent with the organization of components on the Skyway Bridge, the overlays were organized in a manner similar to the items grouped in the spreadsheet: FDOT ITS, FDOT Surveying & Mapping, FDOT State Materials Office, etc. Although Leaflet does not have a native way to efficiently organize groups, it supports third party plugins to address missing features. Several plugins were designed specifically to overcome this limitation on the usage of groups. The particular plugin used for the Skyway Bridge map was Leaflet.StyledLayerControl (<https://github.com/davicustudio/Leaflet.StyledLayerControl>).

3 Existing Installed Hardware

The equipment and monitoring hardware currently installed on the Skyway are described in detail in this section. As with the database and map, the information is organized according to the responsible FDOT office.

3.1 *Intelligent Transportation System*

The Intelligent Transportation System (ITS) Division of the Traffic and Engineering Operations Office provides a range of equipment that monitors traffic, travel conditions, and motorist safety on the bridge but is not intended to monitor the bridge's long-term structural health.

ITS has installed cabinets, similar to the one shown in Figure 3-1, which are located on the side of the road, in the median, or within the main bridge girder. These cabinets are grouped into two types distinguishable by the color of the labeling on the outside of the cabinets. The first type of cabinet is only accessible to ITS personnel, contains ITS-installed equipment, and is maintained by ITS. These cabinets are referred to as "ITS Cabinets" and have black labeling. In addition to being accessible by ITS personnel, the second type of cabinet is also accessible by the District 7 Maintenance Office. These cabinets are referred to as "Maintenance Cabinets" and have white labeling (Figure 3-1). There are currently 13 Maintenance Cabinets, all of which will be maintained by the new asset maintenance contractor.

ITS data is made primarily available to ITS personnel. The wind speed data is used by the Florida Highway Patrol (FHP) to determine if the bridge should be closed due to high sustained wind speeds (> 35 mph). ITS monitoring data is sent to the Traffic Management Center (TMC) located at the rear of the DSMO through one of the several fiber optic networks currently running along the length of the bridge.

ITS also provides fiber optic communication support for the equipment placed in any of the cabinets, including their monitoring equipment in the ITS Cabinets and for the GPS systems installed by the Surveying and Mapping Office in the Maintenance Cabinets. The fiber communication in the Maintenance Cabinets is available to other FDOT offices for use with their equipment on the bridge.



Figure 3-1. An ITS-installed maintenance cabinet located at the center of the main channel span.

The following sections provide details on the ITS components. Overall, the cabinets, conduit, and hardware components appear to be in good condition and equipment is currently operational.

3.1.1 Microwave Vehicle Detection System

There are 16 microwave vehicle detection system (MVDS) sensors on the bridge (Figure 3-2). In the northbound (NB) direction, there are four sensors, one on each tower (MM 10.4 and 10.6) and one at each end of the bridge (MM 7.8 and 13.4). There are twelve sensors in southbound (SB) direction with one on each tower (MM 10.4 and 10.6) and the rest distributed between MM 6.9 and 12.9.



Figure 3-2. The MVDS sensor located at MM 10.6.

3.1.2 Cameras

ITS has 16 traffic/roadway cameras (Figure 3-3a) along the length of the bridge, including one at each of the rest areas on either end of the bridge and two on each tower. There are three thermal imaging cameras (Figure 3-3b), one on each tower and one hanging over the side of the bridge near the South Tower, and seven additional live video cameras (Figure 3-3c) positioned to monitor other areas of the bridge (e.g. access doors into the towers).



(a)

(b)

(c)

Figure 3-3. (a) Traffic camera on the North Tower over the northbound traffic lane, (b) thermal imaging camera on the North Tower, and (c) other camera on the South Tower.

3.1.3 Visibility Sensors

Five Vaisala visibility sensors are located on the bridge (Figure 3-4), with one at each of the towers, one at the center of the main channel span, and one towards each end of the bridge.



Figure 3-4. The visibility sensor located at MM 10.9.

3.1.4 Weather Station

The ITS weather station, by Vaisala, is located at the center of the main channel span (Figure 3-5). The weather station includes an ultrasonic anemometer, an ambient air temperature sensor, and a relative humidity sensor.

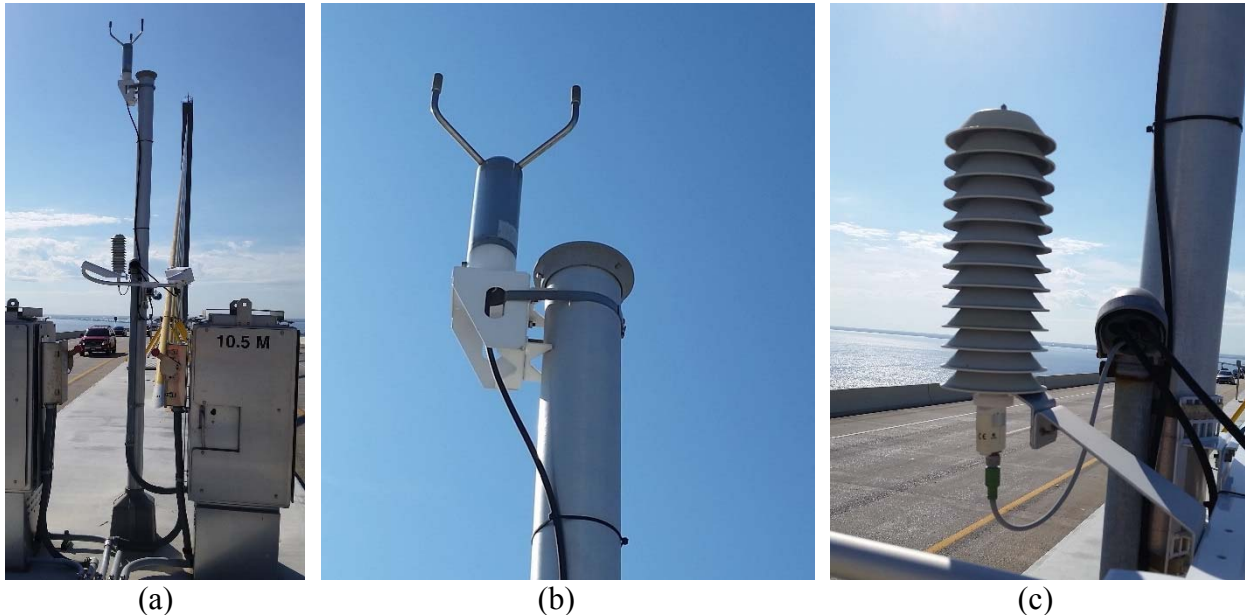

Figure 3-5. (a) ITS weather station at the center of the main span, (b) ultrasonic anemometer, and (c) relative humidity and temperature sensor.

3.1.5 Data Transport

ITS data communication is supported by several fiber optic lines running along the length of the bridge. Optical fibers provide reliable, high throughput data communication without some of the challenges of copper or wireless communication. For example, optical cables have less signal attenuation and electromagnetic interference than wireless communication options. As a result, the data communicated over fiber from the bridge is consistently available. In addition to the inherent reliability of the fiber communication, the fact that it is monitored 24/7 by ITS ensures limited down-time in the event of a communication problem.

The cabinets distributed along the bridge house the network switches that provide the physical connection between the signal lines from the various monitoring equipment and the fiber communication network. Figure 3-6a shows an overview of the contents of one of the ITS cabinets. A network switch (Figure 3-6b) brings in signal data via Ethernet ports and provides two optical fiber ports, which are then connected to a fiber optic patch panel (Figure 3-6c) for data transfer. Additional details on the interface between monitoring equipment and the ITS communication hardware is provided in the Section 3.2.

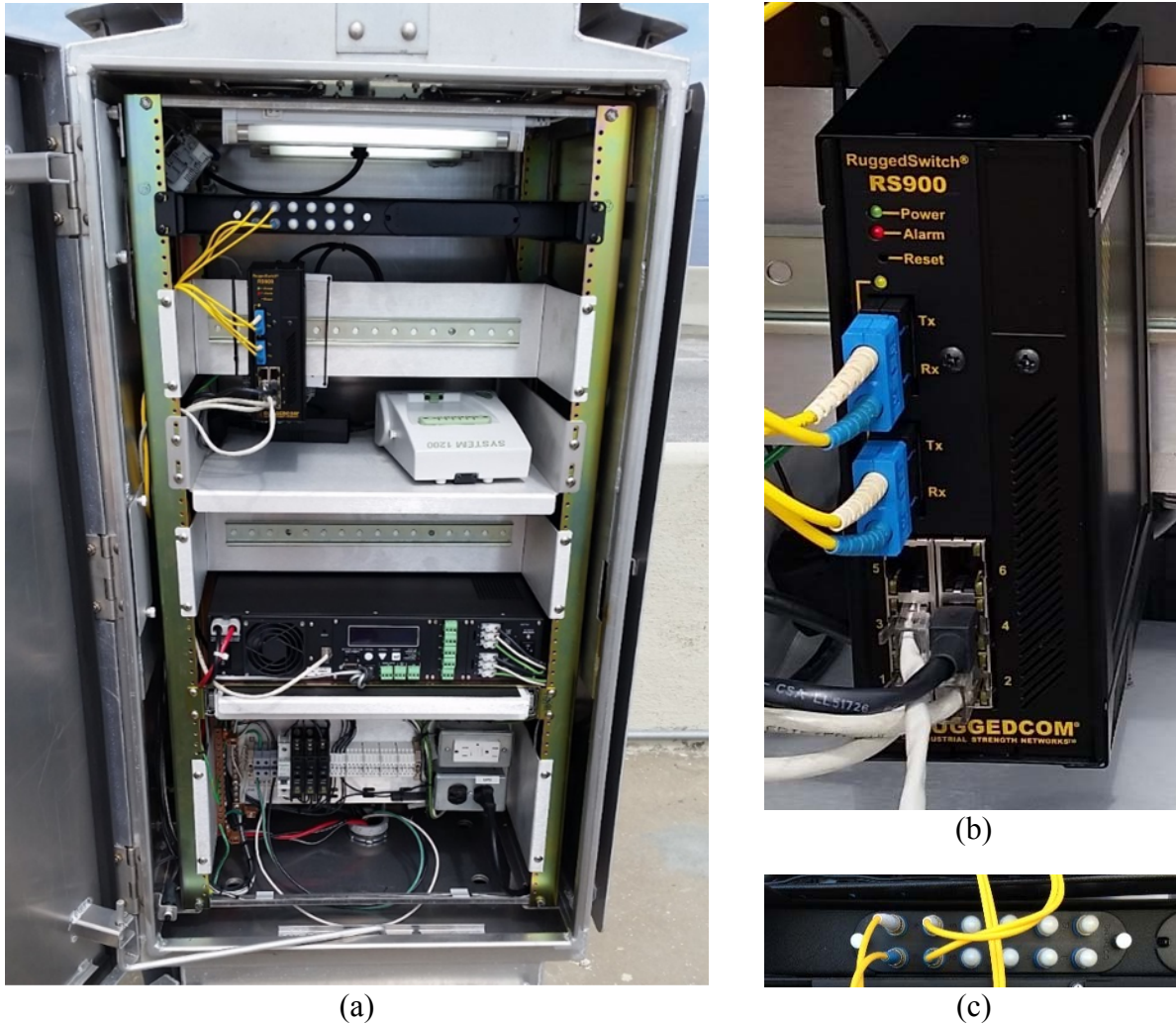

Figure 3-6. (a) ITS cabinet at the base of the South Tower, (b) RUGGEDCOM network switch, and (c) fiber optic patch panel (LIU).

3.2 Surveying and Mapping Office

The Surveying and Mapping Office was the original partner with the District 7 Maintenance Office to provide the monitoring required by the bridge maintenance manual. The goal of their monitoring is to track motion at key points on the bridge. The hardware provided and serviced by the Surveying and Mapping Office includes two subsystems manufactured by Leica Geosystems: 1) GPS (GNSS) antennae and receivers located on the bridge and 2) two automatic motorized total stations (AMTS) formerly located on two of the main dolphins in the vicinity of the bridge that track the motion of targets located on the bridge piers, towers, and under the deck.

The GPS data is collected using the Leica GeoMos software suite developed by Leica Geosystems. Leica GeoMos Monitor is the application responsible for collection of the data, Leica GeoMos Analyzer post-processes the data, and Leica GeoMos Now! makes the data available for visualization on the Internet. Within GeoMos Now!, daily reports are generated to summarize the movement of the GPS antennae. These reports are available on a secure site

hosted by the Florida Permanent Record Network (FPRN). Future GeoMos software revisions are expected to accommodate data from a variety of sensor inputs, potentially enabling its use for a fully integrated monitoring interface.

3.2.1 GNSS Antennae/Receivers

There are five GPS (GNSS) antennae where bridge motion is measured: one at the north end of the main span, Pier 117 (6N), one at the south end of the main span, Pier 106 (6S), one on the top of each tower, and one at the center of the main channel span (see Figure 3-7). Pictures of two of these antennae (others are of a similar type) are shown in Figure 3-8. Table 3-1 provides the location of each GPS antenna/receiver pair.

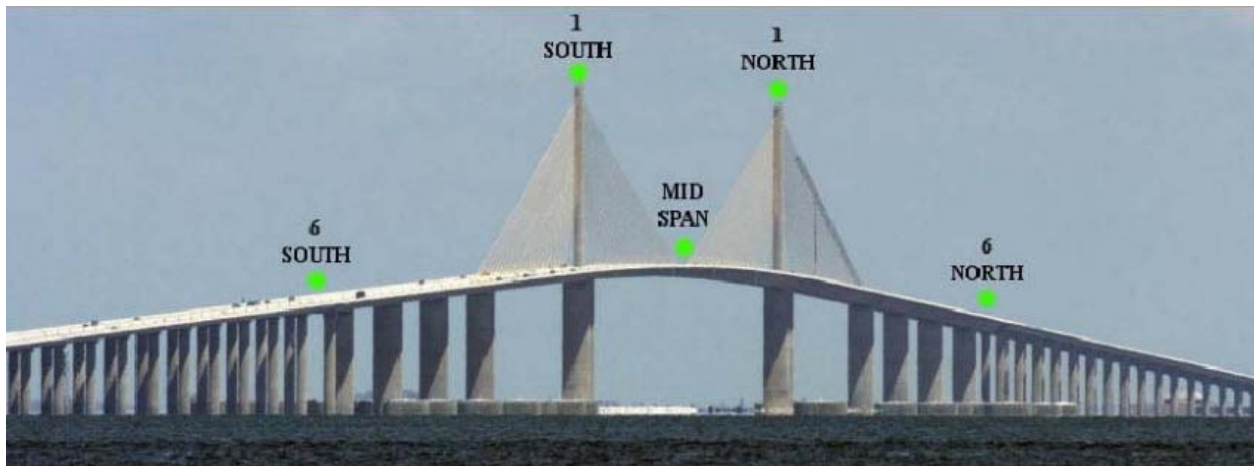

Figure 3-7. Location of GPS antennae.



Figure 3-8. GNSS antennae: south end of the main span (left) and center of the main channel span (right).

Table 3-1. GPS antenna and receiver locations. ID refers to mile marker (101 = MM 10.1) followed by an A (anchor), T (tower), or M (median). Receivers are located inside ITS maintained cabinets.

| General Location | Location ID | Antenna Location | Receiver Location |
|------------------|-------------|------------------|------------------------|
| South main span | 101A | Median | Inside bridge girder |
| South tower | 104T | Top of tower | Bottom of tower median |
| Mid-span | 105M | Median | Median |
| North tower | 106T | Top of tower | Bottom of tower median |
| North main span | 109A | Median | Inside bridge girder |

The signal lines from the GNSS antennae are connected to their corresponding GNSS receivers located in Maintenance Cabinets. Figure 3-9 shows the two types of Leica GNSS receivers in use on the bridge: GR10s at the north end, south end, and middle of the main span and GRX1200s for the antennae on each of the towers.



Figure 3-9. GNSS receivers: GR10 (left) and GRX1200 (right).

3.2.2 Automatic Motorized Total Stations

It should be noted that the AMTS have recently been removed due to their limited functionality; however, they were in place during most of this study. As such, this report presents the AMTS as they were formerly integrated with the Skyway monitoring system. The AMTS were located on two of the main dolphins, one on each side of the bridge (Figure 3-10 and Figure 3-11). Each AMTS was housed in a Plexiglas dome to protect it from the environment. The AMTS on Dolphin 101 (located to the northwest of the bridge) was an older Leica TCA2003 model, while the AMTS on Dolphin 104 (located to the southeast of the bridge) was a newer TM30 model. Fourteen prisms (Figure 3-12) are still installed in the line-of-sight of the former AMTS units at points of interest along the bridge, seven on the Gulf of Mexico side and seven on the Tampa Bay side of the bridge. The AMTS were designed to continuously scan the prisms to create a time history of their motion.

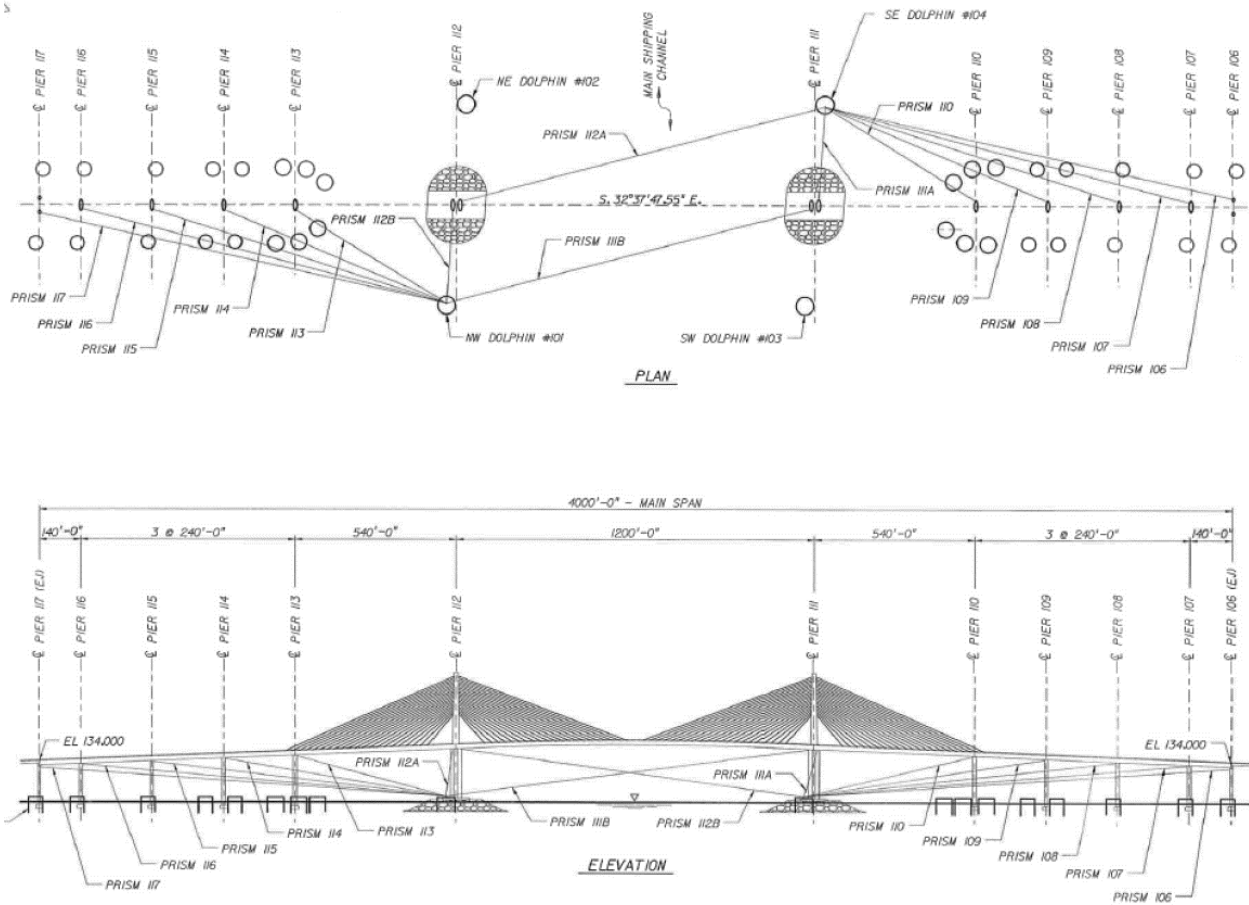

Figure 3-10. Former AMTS and current prism locations, plan (above) and elevation (below).



Figure 3-11. Former TM30 AMTS on Dolphin 104 with solar power (left) and close-up (right).



Figure 3-12. Prism on the North Tower.

3.2.3 Data Transport

GNSS Data Transport

Figure 3-13 shows a connection diagram for the components in the Maintenance Cabinet at the base of the North Tower, and is representative of the other ITS cabinets supporting the GNSS antenna/receiver pairs. The GNSS receivers transfer their signals to the fiber uplink via Ethernet. In addition to the GNSS receiver, the network switch, and the fiber optic patch panel (LIU), the cabinet also contains a switched rack PDU (power distribution unit) and a UPS to provide battery power supply back up.

A potential weakness in the system is the exposure of the antennae and their signal lines to lightning strike; however, as long as the data transfers from each antenna to its receiver, the data is readily available via the fiber uplink. It is also noted that the connections between the antenna and the receivers pass through a surge suppression system such that in the event of a lightning strike, only the antenna and their signal lines to the surge suppression system should be damaged.

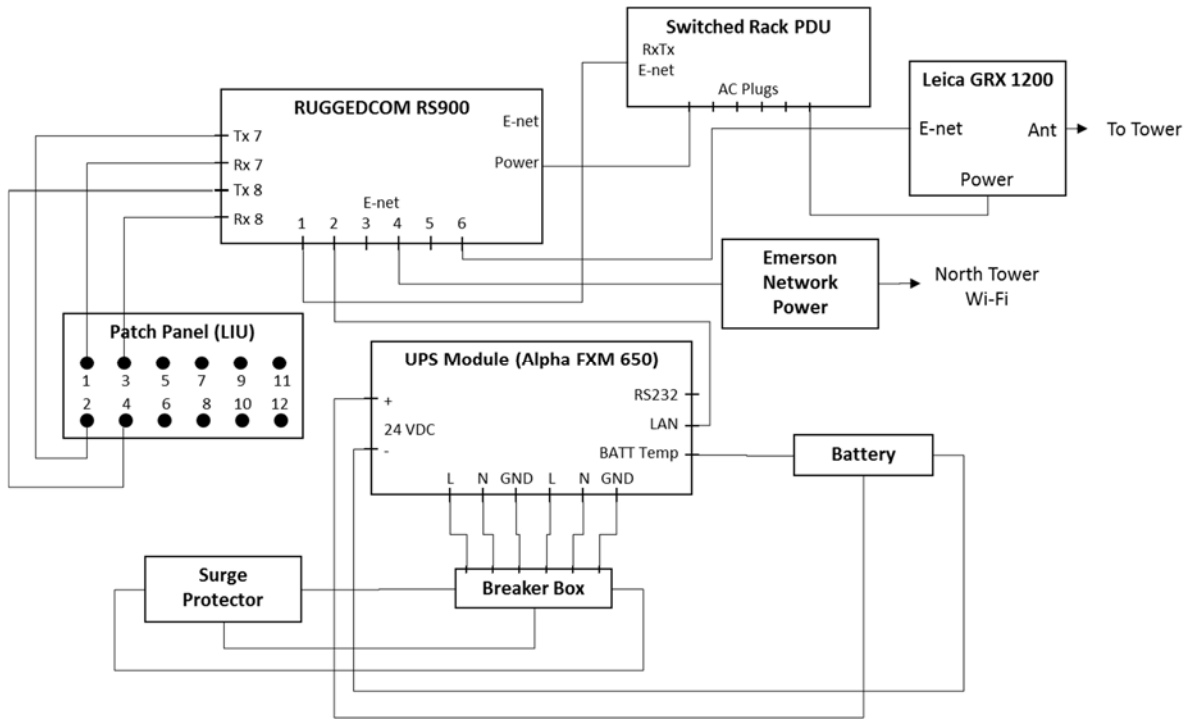

Figure 3-13. Connection diagram of the maintenance cabinet at the base of the North Tower.

AMTS Data Transport

The original intent of the AMTS deployment design was to have target motion data wirelessly communicated to receivers on the bridge or nearby station. However, since the equipment located on the dolphins did not have access to wired power, it relied on a combination of solar panels and batteries. As such, the amount of power available for transmission using any wireless approach was somewhat limited. While this may not have been an issue during fair weather conditions, wireless transmission during severely inclement weather may have been problematic.

Although at least three different communication approaches were attempted, none were consistently successful over an extended period. One communication approach utilized “high-powered” radios to send data from the AMTS on the dolphins to the rest area located at the north end of the bridge. A second approach used Wi-Fi antennas mounted on the towers to receive the AMTS data (referenced in Figure 3-13 and pictured in Figure 3-14). The third approach used cellular uplinks on the dolphins.



Figure 3-14. AMTS Wi-Fi receivers on the North Tower (left) and South Tower (right).

3.2.4 Summary

While the GNSS data are remotely available in real-time, the Surveying and Mapping Office did not have the same success with the data from the AMTS. Having monitoring equipment on the main dolphins poses two distinct challenges for acquiring reliable AMTS data. First, the main dolphins are not wired for power. Any devices present on the main dolphins use solar panels and/or batteries. As such, the deployment of wireless communication devices with large power requirements is not feasible. Second, the distance from the main dolphins to either the bridge or mainland makes lower-powered wireless communications highly unreliable. In addition, the remoteness of the location has also proved challenging for providing a reliable cellular uplink. While it was possible to download data from the AMTS located on the main dolphins manually, this approach required a boat for access, making regular data collection impractical. Direct power and fiber at the dolphins would be required should AMTS units be installed again in the future. Although the installation of new conduit to the main dolphins is likely cost prohibitive, during construction of the main dolphins, conduit potentially capable of bringing both fiber and power to the main dolphins may have been installed. It is recommended that further research be conducted on this conduit to determine its endpoints and current condition to determine its feasibility of use in the future.

3.3 *State Materials Office*

The State Materials Office (SMO) was tasked with providing remote access to the weather stations. They currently maintain two weather stations on the bridge, one at mid-span, and one at the top of the North Tower. SMO has also installed and maintains two cameras monitoring the roadway on the North Tower. The goal of the SMO equipment is to provide continuous weather data and video to the DSMO.

At mid-span there are two thermocouples measuring concrete temperature, an integrated weather station that includes an anemometer (ultrasonic), an air temperature sensor, a barometric pressure sensor, a precipitation sensor, and a relative humidity sensor. All mid-span sensors are solar powered and connected into a data acquisition box designed for the SMO by Environmental Data Systems (EDS), and are located in the median at mid-span. The data collected at mid-span is communicated via several point-to-point radios directed towards a receiver on the North Tower.

The North Tower has two cameras, two thermocouples measuring concrete temperature, and its own integrated weather station that includes an air temperature sensor, an anemometer (propeller type), a barometric pressure sensor, a precipitation sensor, and a relative humidity sensor. All North Tower sensors are powered directly from the bridge main power distribution system and are connected into an EDS data acquisition box located at the top of the tower. The data from both mid-span and the North Tower is designed to be uploaded to an EDS server via a cellular modem located on the North Tower.

The SMO data are sampled every ten minutes. Once transferred to the EDS server, it is made publically available on the internet at <http://myfloridabridges.com>. Currently, there is an issue with the radio linkage between mid-span and the North Tower so the only data remotely available is from the North Tower. The data from mid-span is retrieved manually as necessary.

3.3.1 Weather Station Located at the Center of the Main Channel Span

A Vaisala WXT520 integrated weather sensor (Figure 3-15b) provides measurements of barometric pressure, humidity, precipitation, temperature, wind speed, and wind direction. In addition, two thermocouples (Figure 3-15c) are embedded into the median concrete. The EDS system is housed in a weather resistant box, as shown in Figure 3-15d.

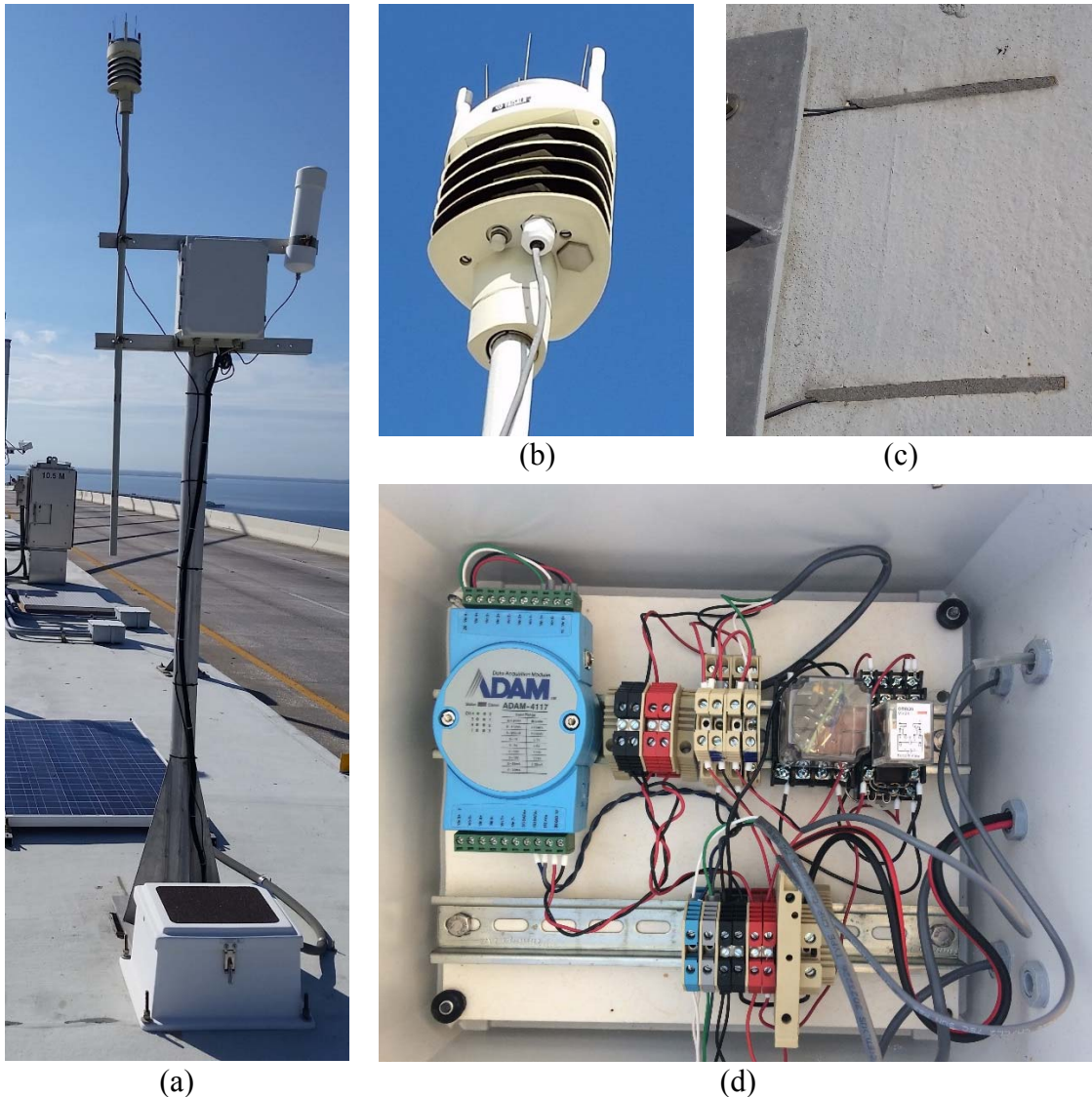

Figure 3-15. (a) Weather station, (b) integrated weather sensor, (c) embedded concrete thermocouples, and (d) interior of the EDS data acquisition and communication box.

3.3.2 Weather Station and Cameras Located at the North Tower

Two video cameras are located on the North Tower, one monitoring the southbound traffic lane and the other monitoring the northbound traffic lane (Figure 3-16). There are two thermocouples embedded in the concrete at the top of the tower (Figure 3-17). The

thermocouple signals are digitized by the Adam 4117 data logger in the EDS box. The integrated weather station, mounted several feet above the North Tower railing, is a Davis Vantage Pro2 with a propeller/cup anemometer, wind vane, temperature and humidity sensors, and a precipitation meter as shown in Figure 3-18.



Figure 3-16. Northbound camera on the North Tower.



Figure 3-17. North Tower thermocouples.

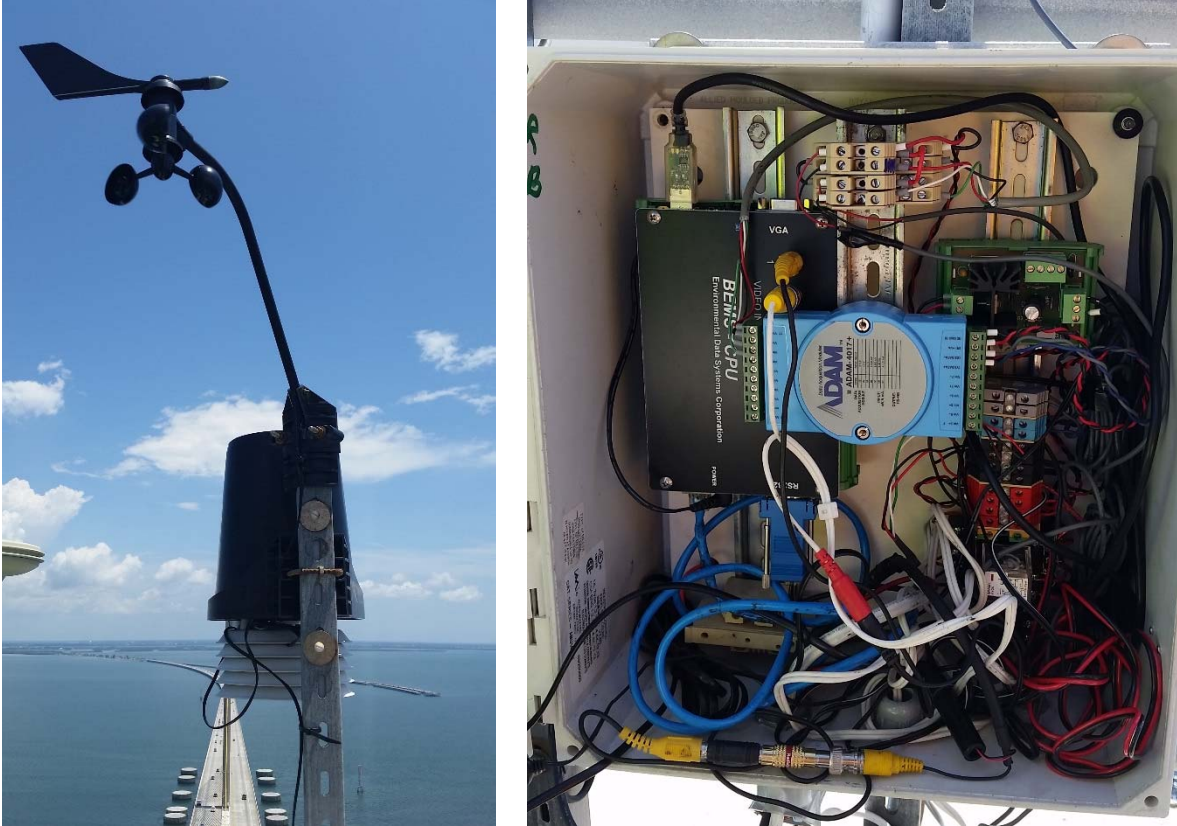

Figure 3-18. North Tower integrated weather station (left) and EDS data acquisition box (right).

3.3.3 Power and Data Transport

Center of the Main Channel Span

Figure 3-19 shows the connections between the various components connected to and within the EDS box. Power is provided to the system via a solar rechargeable 12V battery. The analog thermocouple signals are digitized by an Adam 4117 data logger. There are two options for concrete temperature and weather station data transmission to the North Tower as shown in Figure 3-20. One is a Digi XCite 900 MHz RF modem housed in a PVC tube mounted next to the EDS box (Figure 3-15a). The second is a Digi XStream 2.4 GHz RF modem located in a box mounted on the median below the EDS box (Figure 3-15b). At this time, the communication link to the North Tower is not operational; the cause of the communication problem is unknown but is likely due to the challenging RF communication environment on the bridge.

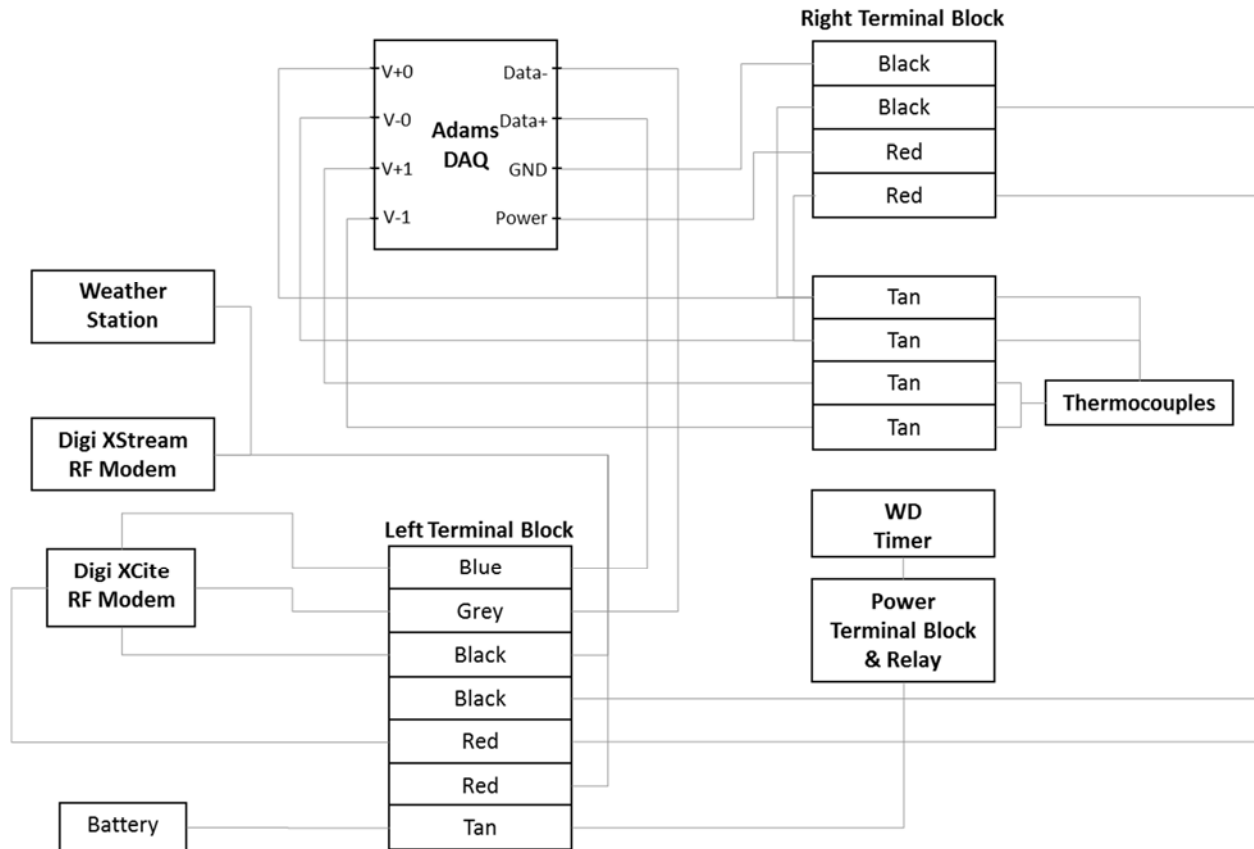

Figure 3-19. Connection diagram for the weather station, thermocouples, and EDS data acquisition box located at the center of the main channel span.



Figure 3-20. Digi XCite RF Modem (left) and DigiXStream RF Modem (right).

North Tower

Figure 3-21 shows the connections between the various components in the North Tower EDS box. Power is provided to the system via a solar rechargeable 12V battery. The central component is the EDS Bridge Environmental Monitoring System (BEMS) CPU, which provides a number of data I/O options. The video feed is connected to the CPU via a RCA connector. The analog thermocouple signals are digitized by the Adam 4117 data logger, which is connected to the CPU via USB. The weather station data are transmitted from the Davis Vantage Pro2 Sensor Interface Module (SIM) (Figure 3-22) to the digital console/receiver (Figure 3-23), then connected to the CPU via RS232. The data from the center of the main channel span (when the communication is operational) is received by an RF modem housed in an

enclosed PVC tube (Figure 3-24a), then connected to the CPU via USB. Finally, all aggregated data from the CPU is sent via a Cradlepoint cellular modem (Figure 3-24a) to the EDS server for processing and display.

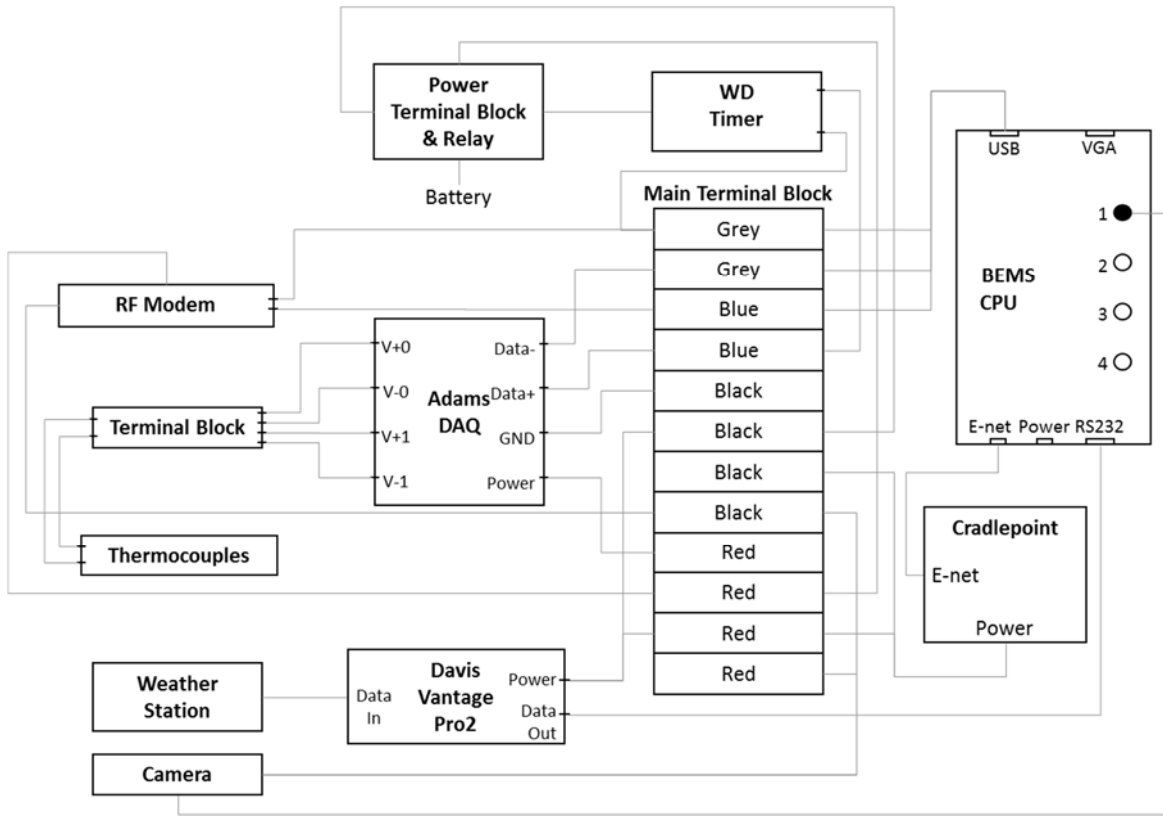

Figure 3-21. Connection diagram for the north weather station, thermocouples, camera, and EDS data acquisition box.



Figure 3-22. Davis Vantage Pro2 weather station sensor interface module.

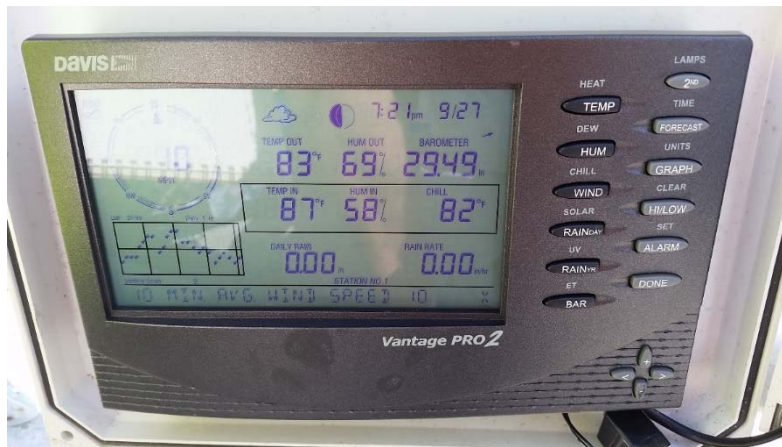

Figure 3-23. Davis Vantage Pro2 weather station console.

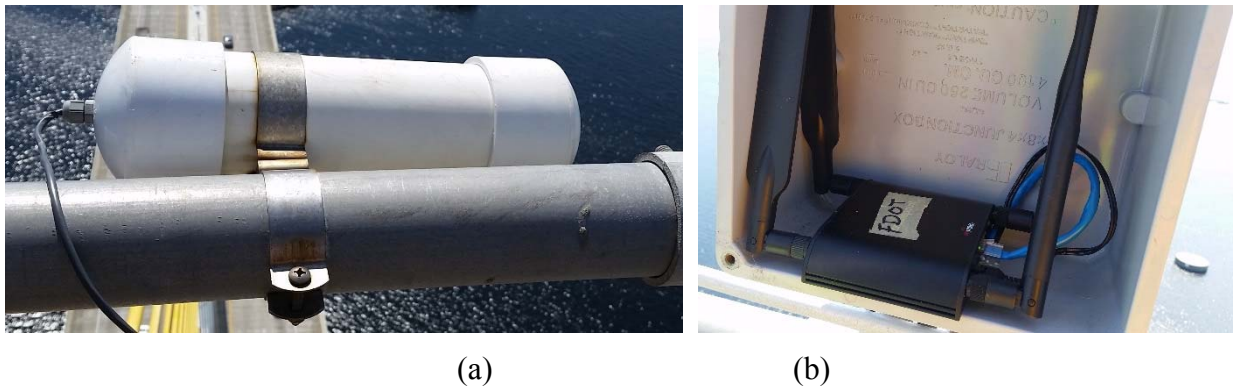

Figure 3-24. (a) North Tower RF modem housing and (b) Cradlepoint cellular modem.

3.3.4 Summary







The primary challenge faced by the equipment operated by the State Materials Office is a lack of reliable power at the mid-span and communication at both the mid-span and North Tower. It is recommended that all equipment, where possible, be connected to the main power systems on the bridge and that communication be implemented through one of the available fiber networks. The success of the GNSS system integration with the fiber optic network demonstrates the reliable data availability provided by this approach.

3.4 *FDOT District 7 Maintenance Office*

A number of lights and beacons on the bridge are provided for safety, visibility, and navigation purposes. The District 7 Maintenance Office is responsible for their maintenance and functionality. These items have been included in the database and interactive map for reference and are summarized, with pictures, in Table 3-2.

Under contract with the District 7 Maintenance Office, Bridge Diagnostics, Inc. (BDI), has installed six tri-axial accelerometers and a weather station, along with a data acquisition cabinet and the necessary power lines and data cables, as shown in Figure 3-25. The purpose of the installation is to provide regular data on the condition of selected cable stays by estimating cable tension from vibration data. One accelerometer is installed at the top of the North Tower, four are installed on cables north of the North Tower, and one is installed at the deck level between the North Tower and Pier 113 (8N). The weather station is installed north of the northern-most cable stay anchor (21N) in the median. The weather station and the cable and deck accelerometers are connected via sensor cables to the data acquisition cabinet installed on the median south of Pier 113. The data from the tower accelerometer are transmitted via a BDI-installed fiber optic cable running through existing GNSS conduit to the deck level and new conduit (extended from the base of the North Tower) to the data acquisition cabinet. The data from the accelerometers will be made available to the District 7 Office via the existing ITS fiber optic communication network.

Table 3-2. Lights and beacons.

| Item Name | Count | Location | Purpose | Picture |
|------------------------------|-----------------------|---|---|---|
| Stay Cable Light | 80 | Median (near stay cables) | Night time stay cable illumination |  A photograph showing a stay cable light fixture mounted on a metal post next to a yellow-painted median on a bridge deck. |
| Bridge Channel Light | 6 | Over main navigational channel | Navigational safety |  A photograph of a tall, slender navigational light tower situated on a concrete pier over a body of water. |
| Rock Island Light | 14 | On the rock islands at the base of the main piers | Navigational safety |  A close-up photograph of a small, cylindrical light fixture mounted on a pile of white rocks. |
| Dolphin Lights | 4 (main) 32 (sup.) | On each dolphin | Navigational safety |  A photograph of a light fixture mounted on a metal structure, likely a dolphin, over water. |
| Tower Obstruction Beacon | 2 | At the top of each tower | Navigational safety and tower obstruction alert |  A photograph of a red cylindrical beacon with a clear lens, mounted on a metal base. |
| Nautical Navigational Beacon | 2 | Southwest and southeast of South Tower | Navigational safety |  A photograph of a tall, lattice-structured navigational beacon tower situated on a platform over the ocean. |

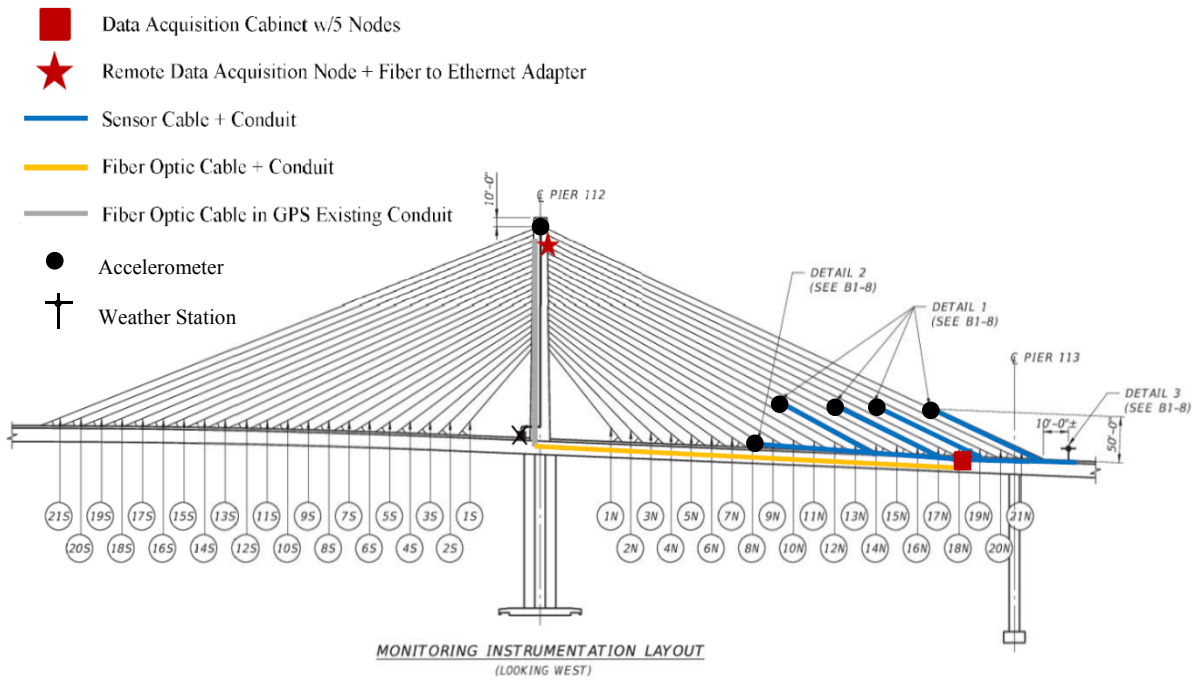

Figure 3-25. Locations of the tower and cable stay accelerometers and data acquisition cabinets.

4 Data Management

Similar to Building Information Modeling (BIM) used in the building construction industry, Bridge Information Modeling (BrIM) provides a data framework for bridge lifecycle assessment and maintenance decision support. This data management framework facilitates the centralization and sharing of information about the structure, which may include three-dimensional geometry, structural materials, inspection reports, maintenance history, and monitoring data (archived and real-time). Such a data framework must have the ability to accommodate both structured (e.g., monitoring data) and unstructured data (e.g., drawings, handwritten notes) from a variety of sources on a large range of time scales. An effective bridge data management framework requires ample and accessible data storage, an appropriate database, data query tools, and a navigable data visualization interface. A Web-based service is well-suited to providing the interface with the data management framework to anyone that is provided access.

The focus of this section of the report is data management specific to monitoring system data, as illustrated in Figure 4-1; however, a monitoring data management plan must consider the larger scope of data management within a comprehensive BrIM design.

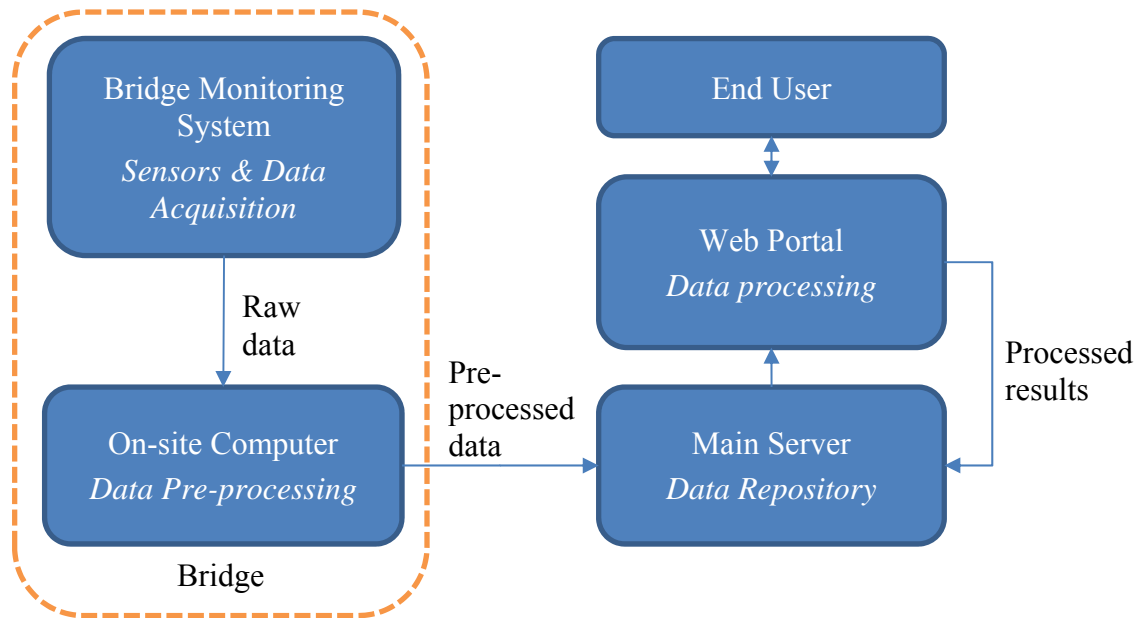

Figure 4-1. Representative data management framework for monitoring data.

4.1 Monitoring Data Types

The sensors and accompanying data acquisition systems on a bridge produce raw digitized data streams. Some sensors and data acquisition systems perform low-level, hardware-based data correction, such as temperature compensation or GPS measurement correction. Data may be either directly transmitted to a main server or undergo additional software-based “pre-processing” locally before transmission. Pre-processing may be simple data cleaning, such as filtering or removing offsets, or it may be more involved, such as the reduction of lengthy time series into just a few derived quantities, resulting in significant data compression.

A pertinent data compression example for the Skyway monitoring system is the potential to pre-process accelerometer data measured on the cable stays to extract cable force estimates, as illustrated in Figure 4-2. The acceleration data (sampled at rates of at least 100 Hz) is filtered and then transformed into a power spectral density (PSD) or a Fast Fourier Transform (FFT) function using a Fourier Transform. The natural frequencies of the cable are then extracted and the cable force is calculated from the natural frequencies. The result of this process is that a lengthy acceleration time history is condensed to a single force estimate. If the force estimate is the only desired measurement from the accelerometers, there is no need to communicate additional data to the main server.

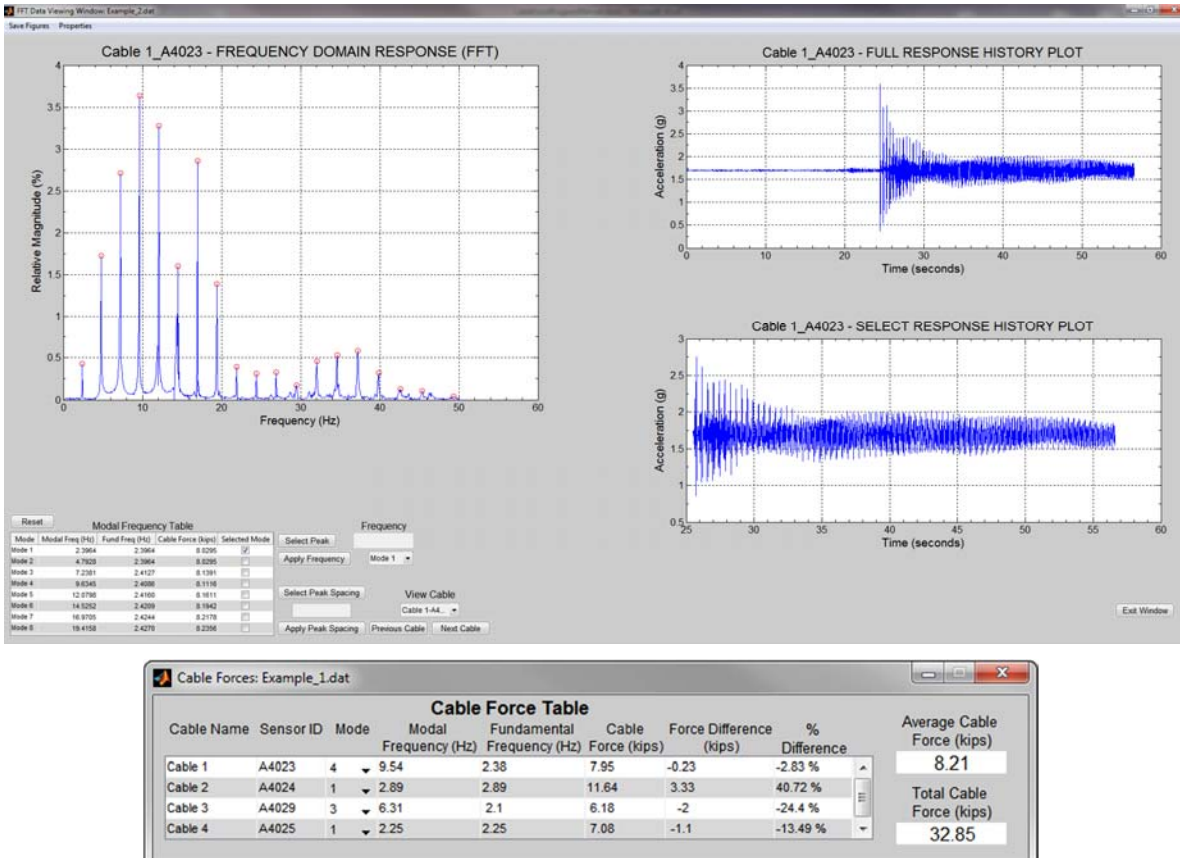

Figure 4-2. Example cable force estimation (bottom) from acceleration time history and frequency domain response calculations (top). (From BDI, Inc. <http://bridgetest.com/products/sts-cfa-cable-force-measurement-software/>).

Measurement data are usually recorded in a single- or double-precision floating point format (32 and 64 bits, respectively) and include 32- or 64-bit time stamps. Uncompressed data are stored in either binary or ASCII formats. Binary formats include raw sensor outputs, which include the exact number of bits of data recorded by the sensors, database formats, video formats (e.g., MPEG-4), machine-independent formats (e.g., NetCDF), etc. ASCII formats include comma/space delimited files, XML, etc. Both binary and ASCII files can be compressed. While “lossy” compression algorithms are commonly used for pictures/video, lossless algorithms should be used for measurement data itself to preserve accuracy. The choice to use compression

depends on the amount of storage available and the ability of the data management architecture to easily work with compressed data. Even if the architecture supports the use of compressed data, computational overhead is added as the un-compression must be done on-the-fly.

More important than the exact form of the data is the necessity of the data format to include as much relevant metadata as is possible. This metadata will include obvious information, such as the type of variable (e.g., acceleration, temperature, etc.) and the units, to less obvious information, e.g. calibration constants, serial numbers or software/hardware versions.

4.2 Data Storage

An optimal data storage solution for a bridge monitoring system depends on the amount of data that the system generates, the amount of data that is to be archived, data security requirements, legal considerations, and data accessibility requirements. The main server is the primary data storage location, although the data may be subsequently mirrored to other locations. The throughput (the amount of data that can be transferred in a given amount of time) and the latency (the amount of time it takes the server to access the first piece of data when queried) of the main server should be assessed when selecting a storage option. In the case of the Skyway monitoring system, latency could cause problems when data-driven alerts require immediate response (such as an impact force which results in a catastrophic failure that may endanger lives).

The options presented for data storage take into account how data will be accessed and visualized by the end user. A “Web portal” provides this access through an interactive Web-based interface. Web portal development and hosting options are discussed further in Section 4.3.

4.2.1 Skyway Data Storage Requirements

The amount of data to be stored from the Skyway monitoring system is a function of the number of sensors, the data type of each sensor outputs, the sampling rate for each sensor, and the pre-processing that occurs before data are transferred to the main server. The daily amount of raw data from each sensor group (separate data acquisition sub-system) is calculated by:

$$DailyDataSize = \frac{SamplingRate \cdot Channels \cdot SampleSize \cdot Duration \cdot 60 \frac{sec}{min}}{(1024 \cdot 1024) \frac{bytes}{MB}} \quad (1)$$

where: *DailyDataSize* = the amount of data generated per day, in MB

SamplingRate = the rate data is sampled when it is being collected, in Hz

Channels = the number of channels per sensor group, including time stamps

SampleSize = the size of each data sample and time stamp (e.g., 8 bytes)

Duration = the amount of time per day that data are collected, in minutes (e.g., 1440 min if continuously saved)

The data storage estimates in Table 4-1 are based on the sensors currently installed on the bridge (as of March 2016) and assume no data pre-processing (i.e., the highest volume data storage scenario). Not including video and without accounting for metadata header files, the sensors produce less than 26 MB per day (10 GB per year).

Table 4-1. Data size estimates based on existing Skyway monitoring sensors.

| Sensor Type | Sensors | Channels | Sampling Rate | Data Saved | Size per Day (MB) |
|---------------------------------------|--|----------|---------------|-------------------|-------------------|
| Accelerometers (DSMO) | 6 | 18 | 100 Hz | 5 min, 2x per day | 8.7 |
| Weather Station (DSMO) | Wind Temperature Humidity | 4 | 1 Hz | Continuously | 3.3 |
| GNSS Antennae (Surveying) | 5 | 20 | 1 Hz | Continuously | 13.2 |
| Weather Station + Thermocouples (SMO) | Wind Temperature Humidity Therm. x2 | 6 | 0.1 Hz | Continuously | 0.5 |
| Total | | | | | 25.6 |

A consideration in designing a new data storage and access plan for the Skyway is ensuring that end users do not lose access to data that is currently under their control. For example, the Surveying and Mapping Office manages and stores the GPS/GGNSS data, while the State Materials Office is responsible for their weather station, concrete temperature, and camera data. It is recommended that the data from all of the monitoring components are connected to the fiber communication network on the Skyway and sent to the same location; however, unrestricted and limited latency access to the data, either directly or replicated, must be provided to the D7 Maintenance Office, the Surveying and Mapping Office, and the State Materials Office.

4.2.2 Data Storage Options

The data storage options presented in this report are the result of correspondence with various FDOT and State offices, including the FDOT Office of Information Technology (OIT) and the Agency for State Technology (AST), as well as discussions with an outside (non-UF) contractor, Bridge Diagnostics, Inc. (BDI). It should be noted that regardless of the selection for the main (primary) server, raw and processed data can be replicated on District (D7) or State (AST) servers.

Centralized Data Storage: Agency for State Technology

Within the context of bridge management carried out by a government agency, there may be legal mandates that dictate how and where data are stored. In 2014, House Bill 7073 established the Agency for State Technology (<http://www.ast.myflorida.com/about.asp>) to provide a consolidated state data center and information technology oversight. While the goal of AST is to streamline state data management, the legislation recognizes that some state agencies

and/or complex data types may warrant exemption from AST storage. Currently, the local District offices have an exemption from storing data with AST. Given the complexity of the data from the Skyway Bridge, and potential latency associated with the AST servers, it is recommended to take advantage of the exemption, assuming similarly reliable storage options can be made available locally. It should be noted, however, that the AST exemption may expire at a future date and should therefore be kept in consideration during the design of a data management architecture.

District 7 Data Storage

The Skyway monitoring data may be stored either locally at the District level on dedicated servers located in the D7 offices, or stored in a cloud-based service (e.g., Microsoft Azure StorSimple) established by the District. OIT can support either data storage option. The Web portal would access the data from either of these storage locations and the necessary data security measures would be established and enforced. A dedicated D7 staff member would be tasked with monitoring the servers and data availability.

University of Florida Data Storage

Similar to District-level data storage, the University of Florida (UF) could provide data storage on dedicated UF-located servers operated by Enterprise Infrastructure Services (EIS) at UF or through a cloud-based service set up by the UF researchers. An advantage of this approach would be that UF researchers would have the responsibility of monitoring the data and could directly trouble-shoot system issues. If UF were to be tasked with creating the Web portal for data processing and visualization, this option would centralize the data management and streamline system optimization and deployment. System and data security would need to be evaluated and addressed for this option.

Contractor Data Storage

The option for third-party data storage may be appropriate if an outside (non-UF) contractor provides the Web portal development and hosting for data processing and visualization (as discussed in Section 4.3). Storing the data on the same server from which the Web portal is executed ensures that the contractor can provide a high quality of service while minimizing latency or data access concerns. Any contractor must be prequalified to conduct work for the State of Florida and all state data security requirements must be satisfied.

4.3 Web Portal

A Web portal is an internet-based interface that provide end users access to interrogate and visualize the processed monitoring data and point cloud surveys. In a portal, a user can manually or automatically create data plots, generate reports, and set alarm thresholds. An interactive visualization interface can use a three-dimensional rendering or an aerial picture of the bridge to provide a means of viewing data or results from various locations on the bridge. An ideal portal can bring in different data types from a number of different sources with different metadata characteristics, sampling rates and structures.

There are companies that provide portals specifically designed for structural health monitoring, such as the Platform Interactive Web application provided by Bridge Diagnostics, Inc. (BDI) partner, DATUM or the Intelligent Decision Support (IDS) platform developed by

CAMGIAN microsystems. During a system commissioning stage, the portal developer works with the end user and examines preliminary data records to establish and refine alarm thresholds, desired reporting functionality, and the general look of the data interface. After the commissioning stage, the data portal software can be hosted by the developer, the end user (DSMO), or another party (e.g., UF). In the case of the DATUM-hosted Platform Interactive data interface, 24/7 monitoring of the system outputs is provided to ensure timely communication of system alarms and event warnings. The monthly cost for DATUM/BDI to host and monitor the Platform Interactive data portal (and store the data) is \$250-\$300, estimated based on the current sensors in place on the bridge and the complexity of the system. Costs of systems provided by other, similar contractors should be evaluated before a contractor is selected.

4.4 Data Management Options Summary

Table 4-2 provides a summary of the data storage and interface development and implementation options available for the Skyway. The factors under consideration include the cost, the development time (how long it will take to implement a functional Web interface), the amount of time D7 personnel will have to devote to system oversight and maintenance, the data quality of service (latency, accessibility, and interaction between the data server and the data portal), and the institutional barriers to implementing the data management solution. The last column of Table 4-2 provides a general rating for each option. The rating is determined by assigning a point value to each category (1 for least favorable to 3 for most favorable) and then summing the points across the categories. The rating is based on the total points to provide a relative measure of the favorability of each option.

The use of a contractor for the data portal development and service is likely to be the costliest option but requires the lowest development time, lowest D7 personnel time, and ensures the highest quality of service. As previously mentioned, data storage using AST has unknown latency that may compromise the quality of service provided by the data portal. The option with the highest rating resulting from the lowest cost, lowest development time ('Dev. Time'), and lowest D7 personnel time is to have UF store the data and host the data portal developed and commissioned by a contractor. Given the history of UF database maintenance projects for the FDOT, the institutional barriers are not expected to be high for this option. It should be noted that the data storage and portal hosting could be transferred entirely to the FDOT (AST and/or D7) in the future, once the system is established and personnel requirements are better understood.

Table 4-2. Data storage and interface strategy comparison (UF = University of Florida, DSMO = District 7 Maintenance Office, AST = Agency for State Technology, and Cont. = non-UF contractor).

| Main Server | Data Portal Developer | Data Portal Host | Cost | Dev. Time | DSMO Personnel Time | Data Quality of Service | Inst. Barriers | Rating |
|--------------------|------------------------------|-------------------------|-------------|------------------|----------------------------|--------------------------------|-----------------------|---------------|
| DSMO | UF | UF | Low | High | Medium | High | Medium | ★★ |
| | Cont. | D7 | Medium | Low | High | Medium | Medium | ★ |
| | Cont. | Cont. | High | Low | Low | Medium | Medium | ★★ |
| AST | UF | UF | Low | High | Low | ? | Low | ★★ |
| | Cont. | AST | Medium | Low | Medium | ? | Low | ★★ |
| | Cont. | Cont. | High | Low | Low | ? | Low | ★ |
| UF | UF | UF | Low | High | Medium | High | Medium | ★★ |
| | Cont. | UF | Medium | Low | Low | High | Medium | ★★★ |
| Cont. | Cont. | Cont. | High | Low | Low | High | High | ★★ |

5 Data Processing for Decision Support

An effective Skyway monitoring system must provide useful information about the condition of the structure as part of a routine monitoring strategy as well as in response to extreme events. Both routine and extreme event monitoring use the same monitoring system framework; the primary differences are evident in the Web portal interface, the data processing schemes, and the event warnings that may be triggered.

5.1 Routine Monitoring

During the first few years after initial deployment of the monitoring system, the bounds of “normal” structural behavior must be established, with the starting points of the bounds determined from design calculations and FE modeling. This process of validating and improving the bounds involves collecting synchronized loading (temperature and wind velocity) and response (acceleration and displacement) measurements at various times of the day and throughout the year to capture diurnal and seasonal response fluctuations, in addition to traffic counts and the expected ranges of traffic loads. After sufficient data has been collected, the statistics of the responses are analyzed and correlated independently to temperature and wind velocity. Once the typical bounds of response (tower motion, deck motion, cable vibration amplitudes, natural frequencies, and cable forces) are established, thresholds may be set. The thresholds may be on the loading (e.g., wind velocity) or on the responses. Careful refinement of the thresholds over the course of a few years is important to minimize the number of unnecessary warnings without missing critical events. It should be noted that threshold refinement may continue throughout the life of the system. The use of a calibrated FE model is effective in establishing thresholds for more extreme loading and response conditions. This threshold establishment process should be initiated with the Skyway monitoring system once the data from each sensor sub-system can be collected simultaneously (so that data may be correlated).

A protocol for responding to threshold exceedance events must be established according to the level of response that each event warrants. For the Skyway, the response protocol for threshold exceedance must be determined by the D7 Maintenance Office and other entities responsible for responding to Skyway events. An example of threshold levels and responses is summarized in Table 5-1, along with a suggested color code that could be indicated in the Web portal.

Table 5-1. Triggered Skyway monitoring events and responses.

| Event Level Trigger | Log Entry | Additional Data Collected | Automatic Warning Message Generated | | | | Automatic Bridge Closure* |
|---------------------|-----------|---------------------------|-------------------------------------|-------------------------|-----|---------------------|---------------------------|
| | | | D7 Office | Asset Maint. Contractor | ITS | Emergency Response* | |
| Low | • | | | | | | |
| Medium | • | • | • | • | | | |
| High | • | • | • | • | • | | |
| Very High | • | • | • | • | • | • | • |

*Emergency response and closure (full or partial) would be coordinated with the TMC.

In each event threshold trigger case, the log and warning messages would identify the condition and/or the region or element of the bridge that is generating the alert so that appropriate action may be taken. In addition to monitoring event thresholds, the routine monitoring system operation will involve the generation of reports on a set schedule, such as on a daily, weekly, or yearly basis. The frequency, extent, and content of the reports would be determined jointly by the Web portal designer/host, researchers/consultants, and the end users (i.e., DSMO).

5.2 Critical Event Monitoring

Evaluating the safety of the Skyway during and following a critical or extreme loading event is one of the most critical functions of the enhanced monitoring system. For the Skyway, these extreme events, although unlikely, may be due to:

- Critical component failure
- Weather (hurricane, large front, tornado, etc.)
- Air/sea vessel impact
- Vehicle accident/explosion
- Malicious action

With the anticipation of extreme weather events, forecasts will provide time to make modifications to the data collection strategy, such as increasing the sampling rates and switching to continuous acceleration data collection. ITS will make decisions on driver safety and bridge closure prior to and during such events based on weather data. The monitoring system and data analysis must focus on structural safety. The measurements of most concern will be bridge continuity, pier motions, cable vibration levels, and the resulting cable force values. Based on these measurements during and following a storm, along with post-event inspection, the safety of the bridge and/or maintenance strategies will be established.

Impacts, accidents, and malicious actions have potentially little-to-no warning; thus, the monitoring system must capture the event and relay the information and threshold exceedance events in real-time. The measurements that will indicate an event of this type will be

accelerations and displacements, assuming the sensors themselves are not destroyed during the event. Due to their higher sampling rate, accelerometers are expected to be the most effective at capturing and locating an impact or blast event. It would be expected that an impact or blast would be evident in more than one sensor (i.e., mitigating an unnecessary warning from a faulty sensor). Beyond acceleration levels, other indicators of safety, such as cable tension, may be used to assess the structure post-event.

A well-calibrated FE model may be used to assess the structural impacts and the resulting response values of extreme event scenarios. These modeled scenarios can inform the placement and types of sensors, and the data analysis procedures that will be most effective for extreme event monitoring and decision support.

6 Finite Element Model Assessment

As discussed previously, a well-calibrated FE model is an important tool in an effective SHM strategy. This section provides an initial assessment of the existing MIDAS model originally developed by Parsons Brinckerhoff, of the Skyway to determine its suitability for integration with the enhanced monitoring system. Although the FDOT has used the model to estimate the response of the bridge under wind loads, it has limited calibration with field measurements, which is essential for accurate response prediction.

The existing model is a simplified FE model (made up of linear truss and beam elements), and is not intended to capture local responses (such as local stresses). Previously, other programs, such as Tango and BDAC, were used to analyze the bridge. Later, discontinued user support of these programs led to the creation of the model using the commercially available MIDAS program. At the time that MIDAS was selected, a few other programs, such as LARSA and LUSAS, were also evaluated.

After consulting with the developer of the model (personal communication, Ledesma, A. Feb. 18, 2016), it was determined that the model was originally prepared to guide repair decision making and to independently verify load ratings of the bridge. For instance, construction stage analysis was conducted to determine the actual load distribution in the bridge resulting from the balanced cantilever construction. Information from the analysis (e.g., actual loads in different structural members) was then used in the development of retrofit strategies. Some model verification has been done by comparing measured cable stay forces (from vibration testing) to design calculations. The vibration test results were similar to the values calculated in the model, and the designer's estimated values.

Based on the assessment of the MIDAS model, some identified limitations include:

- The damper struts and external hydraulic dampers (Figure 6-1), used in the bridge to suppress wind-induced vibrations in the cables, have not been included, making calibration with measured cable vibration data difficult. Cable damping values determined from vibration testing of the stays may be input directly into the model to account for effects of the dampers.
- The bridge foundations have been modeled as completely fixed; however, modeling the supports based on soil spring constants (using existing soil boring data) may be necessary to obtain more accurate response results. To obtain the spring constants, a nonlinear analysis involving soil-structure interaction may be required. Alternatively, reasonable stiffness values can be initially assumed to model spring supports and then tuned to match the model response with field measurements.
- The concrete sections, including girders, pylons, piers, and grouted stay cables, have been approximated using gross or transformed cross-sectional properties.

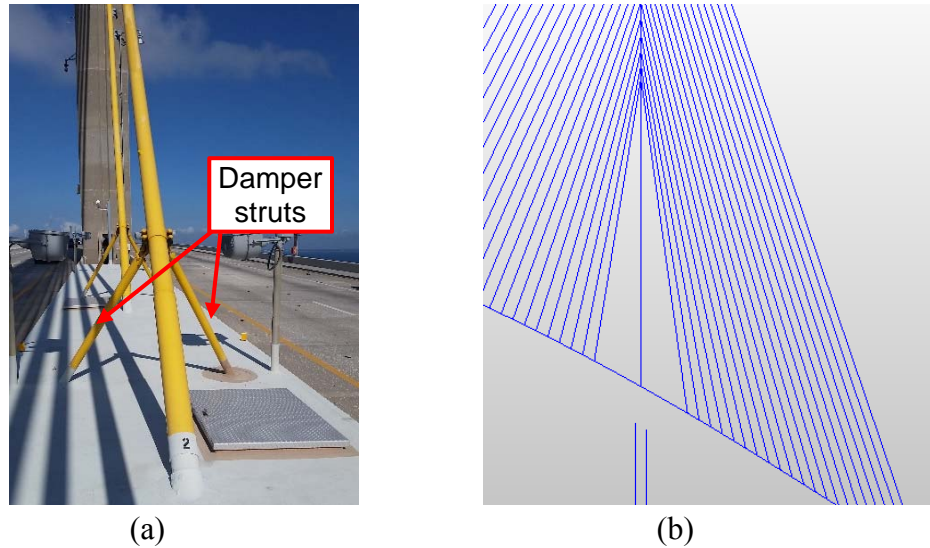

Figure 6-1. (a) Damper struts on the Skyway cables, (b) cable stays without damper struts in the MIDAS model.

One common method for performing FE model calibration is to compare the results of modal analysis of the structure (natural frequencies and mode shapes) from measured results to the dynamic analysis results from the model. The accuracy of the FE model’s natural frequencies are dependent on how well the stiffness, mass, and boundary conditions are modelled. For example, if the modelled natural frequencies are higher than the measured values, it may indicate that the boundary conditions in the model provide too much constraint. By adjusting boundary conditions, mass distributions, and material properties in a way that represents realistic structural conditions, the model may be updated to more accurately capture the true structural response. Other potential parameters from field measurements that may be used to calibrate the model are tower displacements under known wind speeds and temperature gradients and deck movements due to temperature differentials in the structure. Because the model performs a linear analysis, the response can be scaled to match the wind speed or temperature differentials in the field with the model input.

Using a PC with an Intel Core i7-2600 CPU @ 3.4 GHz, 8GB RAM running a 64-bit Windows 7 OS, a complete static and dynamic analysis using the existing MIDAS model runs in less than 10 seconds (analyzing up to 100 dynamic modes). Thus, it may be possible to run the calibrated model from the Web portal to conduct near real-time response estimation from measured wind and temperature values.

Overall, the MIDAS model seems to be reasonable for incorporation with an integrated monitoring system. After some modifications and updates, as noted, and further calibration with measurement data, it will have the necessary functionality for use in a broader bridge information modeling framework. The MIDAS license for an academic institution is \$4,000; the costs associated with its ongoing use by the FDOT must be established. The time and cost of the construction of an FE model with newer software that reflects the most up-to-date bridge conditions and surveying data may also be considered.

7 Skyway Monitoring System Recommendations

This section provides a comprehensive set of recommendations for upgrading the Sunshine Skyway Bridge monitoring system to achieve the long-term goals of the research and meet the ongoing needs of the FDOT Skyway maintenance office. A recommended process for implementing the proposed monitoring system in a Phase II project is discussed in Section 8.

7.1 *Monitoring Hardware*

The recommended hardware upgrades are divided into three categories: 1) bridge movement measurement 2) environmental measurement, and 3) data acquisition.

7.1.1 Bridge Movement Measurement

Temporal tracking of bridge motion provides insight into how the bridge responds to temperature changes, loading conditions, etc. and may indicate when the bridge has sustained structural deterioration or damage. With adequate data collected under routine conditions, amplitudes and frequencies of expected motion may be established and used as baselines for the detection of anomalous behavior.

Bridge motion occurs continuously and at a range of frequencies. Very slow and sometimes permanent movement or position change may be the result of foundation settlement. This type of position change may be tracked infrequently (only a few times a year). Other motion, such as the temperature-induced motion of the towers, will be cyclic throughout the day and require more frequent measurements (e.g., every minute) to capture the full range of change. The natural frequencies of vibration of the structure (e.g., flexure of the bridge deck) or components (e.g., vibration of cable stays), occur at even higher frequencies. To capture these dynamics, data must be collected at a rate at least two times higher than the frequency of the motion. For example, measuring the vibration of the stay cables requires the collection of vibration data up to 100 Hz. High frequency measurements are also required for capturing very short duration events, such as an impact to a pier.

The types of structural motions and the frequency at which the motion data are collected dictates the types of measurement systems that are most appropriate. Table 7-1 summarizes each motion timescale of interest and the type of measurement system (current or recommended, as described in more detail below) that may be used to capture it.

Table 7-1. Bridge motion measurements.

| Motion Type | Measurement Methods | Measurement Time Scale |
|--|--|--|
| Long-term or permanent movement (due to impact or environmental factors, not necessarily a slow process) | Survey (Laser/3D Point Cloud) AMTS/Prisms GNSS (GPS) Tiltmeters | 1 – 2/year (10 – 100/second for tiltmeters) |
| Loading and temperature induced cyclic motion | AMTS/Prisms GNSS (GPS) | 1 – 10/minute |
| Global structural dynamic response | GNSS (GPS) Accelerometers Tiltmeters | 1 – 10/second |
| Structural/component dynamic response Short duration load and response (e.g., impact) | Accelerometers Tiltmeters | 10 – 100/second |

The current approach to directly measure the movement of specific locations on the Skyway use GNSS (GPS) installed at five locations on the bridge. Although the previously installed AMTS had the potential to provide bridge motion at many more points (including locations on the substructure) than the GNSS due to the large number of targets on the bridge, they proved unreliable, not providing useful data for some time. The AMTS units were over 10 years old and their replacement would be a significant expense (over \$30k for new units).

The positions of the GNSS antennae are measured once per second (1 Hz). With the exception of physical damage to the equipment that occurs periodically due to lightning strikes (for example, in the first few months of 2016), the GNSS have provided reliable displacement/movement data for several years. Based on correspondence with the Surveying and Mapping Office, at least four GNSS antennae/receivers are available in FDOT surplus. The addition of four new antennae along the length of the bridge would enhance the temperature and loading response monitoring of the bridge, while better capturing the low frequency global dynamics of the structure.

GNSS observations are obtained through monitoring of signals received from a global network of satellites. While at least three satellites must be “visible” to the antenna, the more satellites that can be seen, the more accurate the measurements obtained. As such, the placement of antenna under the bridge deck is problematic, thus an alternate measurement solution for substructure movement must be sought since the AMTS units have now been removed. Once again, a distinction can be made between movement that occurs over a long period and sudden or short-duration motion. For the former, regular (twice yearly) surveys will suffice for tracking movement. For the latter, tiltmeters installed at the tops of the piers can provide continuous tilt data should either long-term or sudden movement occur. Tiltmeters are inertial sensors that measure tilt or rotation angles. For example, BDI, Inc., the contractor that provided the accelerometers on the cables stays, makes a tiltmeter that has sub arc second accuracy, which would correspond to less than 10 mil (0.01 in, 0.25 mm) translational movement at the top (bearing level) of one of the two main Skyway piers.

The benefits of using accelerometers for bridge monitoring, include providing complementary measurement data to enhance the GNSS measurements (i.e., improve the measurement accuracy), estimating stay cable forces, and tracking changes in the global dynamic properties of the structure. Based on these benefits, several recommendations have been made for accelerometers. Note that, where possible, the accelerometers should be co-located with existing or recommended GNSS to enable data integration and correlation.

Movement and Dynamic Measurement Recommendations:

- Conduct a 3D laser scan of the bridge yearly to track long-term or permanent settlements (as offered to the DSMO by the Surveying and Mapping Office)
- Add four GNSS antennae and corresponding receivers to additional deck level locations on the bridge (Figure 7-1), preferably from FDOT surplus to minimize costs
- Install biaxial tiltmeters to measure tilt in two planes (north/south tilt and east/west tilt) at the tops of South and North piers (Piers 111 and 112) to capture any pier motion that may occur between surveys (Figure 7-2)
- Monitor the data from the currently instrumented cable stays to develop standard vibration signatures to be used in the establishment of amplitude, frequency, and force thresholds
- Install triaxial accelerometers on additional cable stays (e.g., South Tower stays), based on the results of the initial cable stay monitoring period
- Install additional triaxial accelerometers (of similar specifications to those recently installed on the stay cables by BDI, Inc.) at the deck/girder level (Figure 7-3)
- Install a triaxial accelerometer at the top of the South Tower (Pier 111)

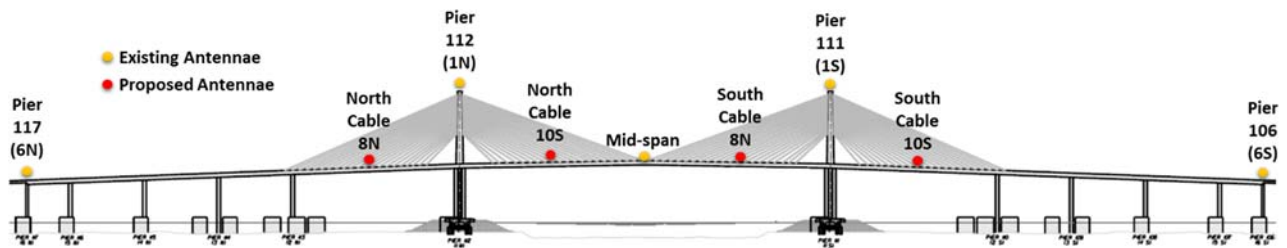

Figure 7-1. Existing and proposed GNSS antennae locations.

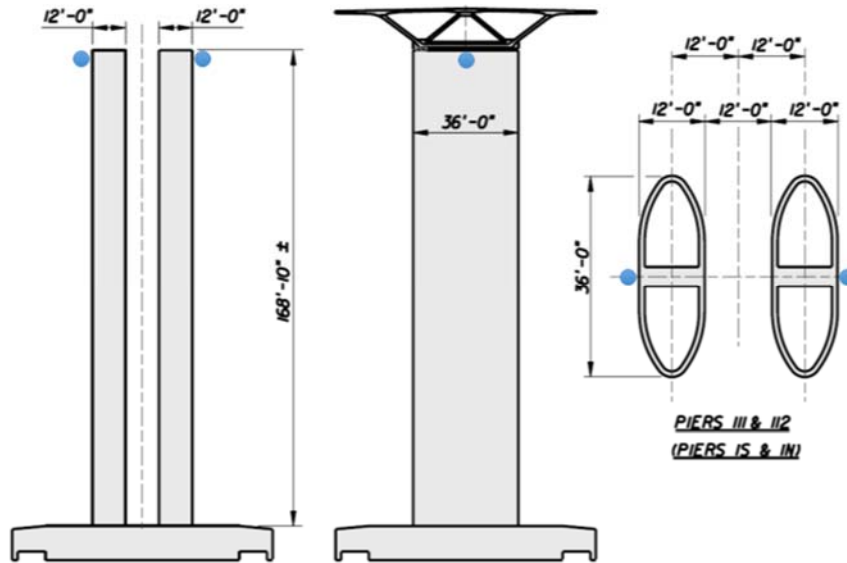

Figure 7-2 Proposed tiltmeter locations, shown with blue dots, on the South and North Towers (Pier 111 and 112).

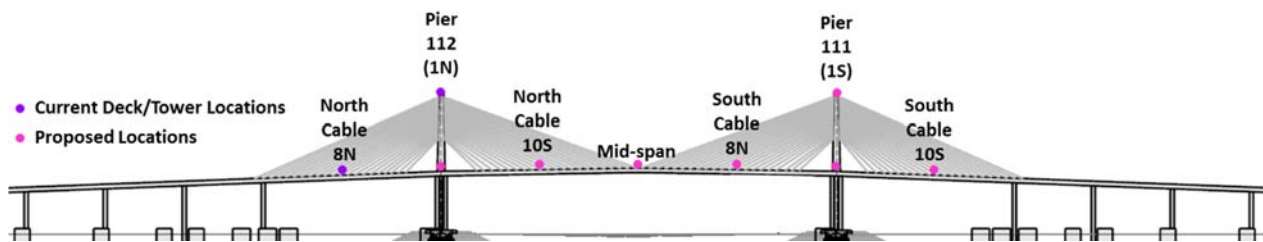

Figure 7-3 Current and proposed deck and tower accelerometer locations.

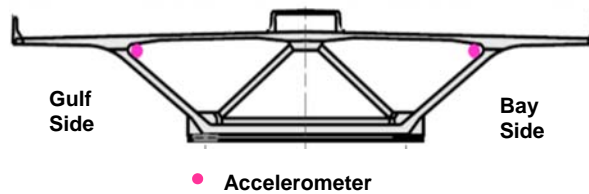

Figure 7-4 Proposed accelerometer locations, shown with pink dots, within main span girder.

7.1.2 Bridge Environment Measurement

There are currently four weather stations on the Skyway: two at mid-span (one belonging to ITS and one to the SMO), one at the north end of the North Tower cables (D7 Maintenance), and one at the top of the North Tower (SMO). All weather stations measure temperature, humidity, air pressure, and wind speed/direction. The SMO weather stations also have thermocouples embedded in the nearby concrete to provide an indication of the material temperatures. It is not necessary to retain all four weather stations in the integrated monitoring system once all offices have access to the weather data. Weather stations at the deck level should provide similar data to one another; however, the North Tower weather station will offer

different measurements due to changes in the wind and thermal profiles as the height above the water increases.

Environmental Sensor Recommendations:

- Retain the weather station installed by DSMO/BDI at north end of the stay cables connected to the North Tower
- Retain the SMO weather station installed at the North Tower (or consider replacing it with newer hardware) and connect it to the BDI data acquisition cabinet at the base of the North Tower (note that the wind conditions will be different at the top of the tower compared to at the deck level)
- Install additional thermocouples within the concrete box and pylons to track thermal gradients that may contribute to diurnal and seasonal movement of the bridge
- Access the data from the mid-span ITS weather station and remove the mid-span SMO weather station

7.1.3 Data Acquisition

Additional data acquisition cabinets and data acquisition hardware, in addition to power and communication access, will be required to support the recommended new instrumentation. The data acquisition cabinet recently installed for the accelerometers may be used to support the additional sensors proposed in the vicinity of the North Tower (Pier 112), with only additional conduit and cable installation required. A similar cabinet and conduit/cable layout near the base of the South Tower can be used for the sensors proposed for that region of the bridge. All data acquisition hardware and cabinets should be designed for future expansion (additional data channels). The details of the locations and number of data acquisition cabinets will be based on the locations and number of new sensors installed and will be determined with input from the various Skyway stakeholders. Either the DSMO or ITS will be designated to have responsibility to maintain the equipment in the cabinets.

7.2 *Data Access and Web Interface*

Several options for integrating, storing, reporting, and visualizing the data from the Skyway have been outlined in Section 4. The options took into account the need for a single interface capable of bringing in and analyzing data from different data acquisition systems sampled at different frequencies, while providing timely, automated alerts to stakeholders. Based on the presented options and ongoing conversations with the Skyway stakeholders, the following data integration framework is recommended (as illustrated in Figure 7-5):

Data Access, Transport, and Storage Recommendations:

- Create a VLAN (a virtual network on the physical fiber used to simplify network organization and access control) on the Skyway fiber network and move all sensor data acquisition subsystems to it
- Grant all end users and developers, including UF and FDOT offices, access to the proposed VLAN portion of the Skyway fiber network and associated data acquisition subsystems via VPN (current connection methods may be retained until satisfactory access is achieved for all)

- Store all data and metadata in a format that enables use by all stakeholders (e.g., non-proprietary formats such as XML)
- Hire a contractor to develop the integrated Web interface and associated data processing, correlation, and visualization tools and make it available to all stakeholders
- Transfer data from the VLAN to an appropriate server(s) at the Agency for State Technology (AST) and the Web interface contractor
- The Web interface contractor will host the integrated Web interface on their server(s) with data processing, correlation, and visualization tools
- For the immediate future, retain the license to Leica GeoMos to view Skyway GNSS data
- Once the Web interface has been shown to operate satisfactorily for all stakeholders, investigate the possibility of discontinuing the use of the Leica GeoMos license for Skyway GNSS data

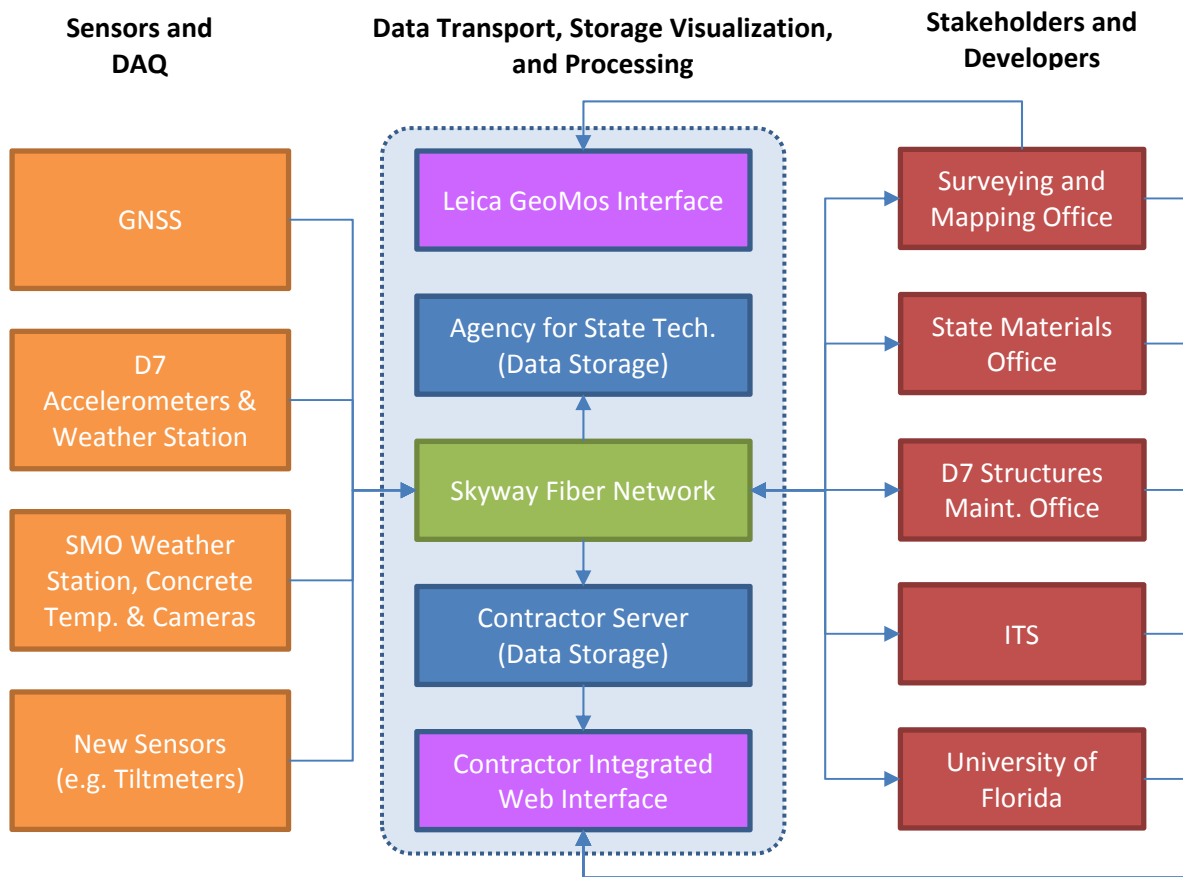

Figure 7-5 Recommended data access and interface.

As noted earlier, Section 4 provides some options related to the development of an integrated Web interface. Recommendation options for creating the Web interface include the following:

Integrated Web Interface and Tools Developer Recommendations:

- Assemble a small team of invested stakeholder representatives (possibly including select members of the Skyway Preservation Committee, the Asset Maintenance Contractor, and ITS representatives) to develop initial design specifications and set appropriate expectations
- Contract with monitoring system Web interface developers
- Employ another contractor (e.g., UF researchers for the duration of a Phase II project and possibly beyond) familiar with the Skyway stakeholders, bridge monitoring, and simulation techniques, to serve as a liaison between the developer and stakeholders who will assist with both contractor management as well as develop appropriate loading thresholds using long-term data measurements and a calibrated FE model

7.3 Inventory Database and Interactive Map

As discussed in Section 2, a comprehensive database and corresponding interactive map have been created to inventory equipment and monitoring hardware currently installed on the bridge. In both the database (Excel spreadsheet) and map, the items are divided into categories based on the FDOT office responsible for their installation and maintenance. Included are descriptions of sensors on the bridge, key supporting infrastructure (e.g., networking equipment), other points of interest, repositories of digital photographs and datasheets, and the interactive Web map. A guide to editing the inventory database and interactive Web map can be found in the Appendix.

Inventory Recommendations:

- Assign a single person to be responsible for keeping the Skyway inventory and interactive map up-to-date. This person will be responsible for the “master copy” of the database and Web map which can be made available to relevant stakeholders, as necessary
- Require that the installation of ANY new sensors or the significant modification of existing sensors on the Skyway to be coordinated with the inventory maintainer
- Develop a process by which an installer of new equipment provides all pertinent information about the sensor (purpose, sample rates, datasheets, pictures of the sensor after deployment, and location information) to the inventory maintainer for the purpose of keeping the inventory current
- Integrate Excel database and map into a single authoritative source to avoid the need to maintain information in two places

8 Monitoring System Implementation

The original plan for achieving an enhanced monitoring system was that the implementation of the recommendations made in Phase I of the research would be carried out in a Phase II project. A staged approach to a Phase II project will ensure consideration of, and input by, each of the FDOT offices involved. The following proposed stages provide tentative timeframes for the implementation of the monitoring system; the actual timeline will depend on stakeholder and contractor scheduling. For each task, the involved stakeholders are listed in square brackets. The Contractor refers in general to the third-party consultant expected to be involved in the task.

Phase II:

Stage 1

- Finalize plan for additional sensors or modifications to existing sensors [UF, DSMO]
- Connect existing accelerometers to fiber [BDI, DSMO]
- Grant network access to the appropriate Skyway fiber network to SMO, DSMO, UF researchers, and Contractor [ITS]
- Set vibration and frequency thresholds for routine behavior of the instrumented cable stays based on data collected to date [UF and Contractor]
- Designate an FDOT employee to maintain the Skyway inventory database and interactive map [DSMO]

Stage 2

- Connect SMO sensors and data acquisition to fiber – make hardware upgrades as necessary [SMO and ITS]
- Add GNSS antennae and corresponding receivers at additional locations identified in Section 2 and connect to the fiber network [Surveying and Mapping]
- Begin the development of data correlation and integration algorithms for accelerometers, GNSS, temperature data, and proposed tiltmeters [UF]
- Develop the design specifications for the integrated Web interface (analysis techniques, alerts, etc.) [UF, DSMO, Contractor]

Stage 3

- Plan and install additional accelerometers and proposed tiltmeters and update inventory database [UF, DSMO, Contractor]
- Determine initial temperature- and wind-correlated bridge movement and natural frequency thresholds [UF]
- Design and establish bridge safety response plan with ITS, FHP, Asset Maintenance contractor, US Coast Guard, and DSMO; coordinate with existing safety plans already in place [ITS, UF, DSMO]

- Generate an updated 3D point cloud and integrate results in Web interface. Determine a schedule for how often surveys will be carried out [Surveying and Mapping, DSMO, UF, Contractor]
- Provide stakeholders access to the Web interface [Contractor, ITS]

Stage 4

- Refine operational and safety thresholds based on long-term data collection [UF, Skyway Committee]
- Perform FE model updating (refinement of stiffness, mass, boundary conditions, etc.) based on long-term data collection [UF]
- Develop user manuals and training documents for the entire monitoring system [UF]
- Establish protocols for adding future sensors and data processing technologies to the monitoring system [UF]
- Establish a system calibration and maintenance schedule for the monitoring system [UF, DSMO]
- Schedule and facilitate training sessions for all users [UF]

9 Conclusions

This report summarizes the monitoring systems installed and maintained by the various FDOT offices involved with the Sunshine Skyway Bridge maintenance and operation. The current decentralized approach to data collection and monitoring on the bridge has resulted in a number of inefficiencies in the methods by which equipment is maintained and observational data are obtained. Although the safety of day-to-day bridge operations is not being compromised, the existing inefficiencies and challenges would be mitigated by a more robust, holistic monitoring system design, which would also support system expansion to accommodate additional sensors and more sophisticated monitoring approaches.

This report has outlined recommendations for achieving an enhanced and fully integrated Skyway monitoring system. These recommendations are intended to meet the needs of all relevant FDOT offices while providing a centralized solution for continuously monitoring the structural safety and functionality of the bridge. Reaching the goals of these recommendations will require input and cooperation from the FDOT offices, with some upfront investment of time and resources necessary to achieve a sustainable system. While overall costs are not discussed specifically, the recommendations herein are intended to provide monitoring solutions that manage both up-front costs and long-term system maintenance costs. The monitoring system will require that at least one FDOT employee have the responsibility for its operation and maintenance, while effectively coordinating with all stakeholders, as part their job duties.

References

- Abdel-Ghaffar, A. M., and Scanlan, R. H. (1985). "Ambient Vibration Studies of Golden Gate Bridge: I. Suspended Structure." *J. of Engineering Mechanics*, 111(4), 463-482.
- Brownjohn, J. M. W. (2007). "Structural health monitoring of civil infrastructure." *Philosophical Transactions of the Royal Society A: Mathematical, Physical and Engineering Sciences*, 365, 589-622.
- Caicedo, J. M., Clayton, E., Dyke, S. J., Abe, M., and Tokyo, J. (2002). "Structural health monitoring for large structures using ambient vibrations." *Proc. of the ICANCEER Conference*, Hong Kong, August 15-20.
- Çelebi, M. (2006). "Real-time Seismic Monitoring of the New Cape Girardeau Bridge and preliminary analyses of recorded data: An overview." *Earthquake Spectra*, 22, 609.
- Hartnagel, B., O'Connor, J., Yen, W., Clogston, P., and Çelebi, M. (2006) "Planning and Implementation of a Seismic Monitoring System for the Bill Emerson Memorial Bridge in Cape Girardeau, MO." *Proc. ASCE Structures Congress 2006*: pp. 1-8.
- Jang, S., Jo, H., Cho, S., Mechitov, K., Rice, J.A., Sim, S.H., Jung, H.J., Yun, C.B., Spencer Jr., B.F., and Agha, G. (2010). "Structural Health Monitoring of a Cable-stayed Bridge using Smart Sensor Technology: Deployment and Evaluation." *Smart Structures and Systems*, 6(5-6):439-460.
- Lovejoy, S. and Myers, B. (2012). "Effective Use of Structural Health Monitoring for Highway Bridge Maintenance." *Proc. Maintenance Management 2012: Presentations from the 2012 AASHTO-TRB Maintenance Management Conference*, July 15-19, 2012, Seattle, Washington, pp. 109-116.
- Mehrabi, A. (2012). "Limited cable stay monitoring of the Sunshine Skyway Bridge." BES Project No. FL-12-01, Progress Report to Parsons Brinckerhoff, Inc. for the Florida Department of Transportation.
- Pakzad, S.N., Fenves, G.L., Kim, S., Culler, D.E. (2008). "Design and Implementation of Scalable Wireless Sensor Network for Structural Monitoring." *ASCE Journal of Infrastructure Engineering*, 14(1): 89-101.
- Rice, J.A, Mechitov, K., Sim, S.H., Nagayama, T., Jang, S., Kim, R., Spencer Jr., B.F., Agha, G. and Fujino, Y. (2010). "Flexible Smart Sensor Framework for Autonomous Structural Health Monitoring." *Smart Structures and Systems*, 6(5-6): 423-438.
- Shenton III, H. W., Chajes, M. J., Wenzel, G., Ramanna, N., AlKhateeb, H., Davidson, K., and Marquez, P. (2014). "Structural health monitoring of Delaware's Indian River Inlet Bridge: year one update." *Proc. ASCE Structures Congress*, pp. 345 – 355.
- Wong, K. Y. (2004). "Instrumentation and health monitoring of cable-supported bridges." *Structural Control and Health Monitoring*, 11(2), 91-124.

Appendix: A User's Guide to Editing the Inventory Database and Interactive Web Map

To identify and assess the condition and challenges of the existing monitoring hardware currently (or soon-to-be) installed on the Sunshine Skyway Bridge by the FDOT and other organizations, a comprehensive inventory database and interactive Web map were developed as part of Task 2 of the Phase I research project. The inventory database consists of a Microsoft Excel spreadsheet with tabs used to organize the data by responsible party or type of data. The interactive Web map was constructed using Leaflet, an open-source JavaScript library. Both the database and Web map have been provided to the FDOT as part of two zipped files. The larger of the two files contains tiled images of the base map of Tampa Bay, FL, while the smaller file contains the inventory database, Web map, data sheets and necessary html and JavaScript libraries necessary to view/edit both the database and Web map from any computer locally using only a Web browser. Alternatively, the content of these two zip files could be placed on an intranet/internet-facing Web server to allow multiple people the ability to view the same data simultaneously. As ALL files used for the development of both the map and database have been provided, it is relatively easy for current/future users to add additional information to both the database and Web map. This is significant, as it provides a medium for researchers and the FDOT to expand or minimize the inventory and map to their specific needs. This document serves as a guide for editing (add/edit/delete) data within the database and Web map.

To begin, the two zip files are copied to a folder and then unzipped in place. With this local copy, it is possible to edit the map to one's preference, as any changes will be referred to information solely stored on the user's personal computer (as can be seen by the path displayed in the Web browser when the index.html file is opened). To illustrate how to add additional data to the database and Web map, a simple example follows below which leverages the high resolution base map of the bridge to identify and mark all of the cars on the main channel span. While not useful in and of itself, this example is representative of other more useful information which could be added to the database and Web map such as the locations of new sensors, pavement test sections, previous/future maintenance work, etc.

A1 Editing the Interactive Map

A1.1 Establishing Points to Place Markers

The markers that show up on the map when a category is chosen are placed based on map coordinates of the basemap (and its associated tiles). The coordinates reflect a specific position that is unique to a certain point on the photograph, and are placed on points of interest that the user wishes to identify and elaborate on. For example, on the initial map, when the user clicks on the control panel icon in the upper right hand corner, a list of offices is displayed that have different devices on the bridge. For the FDOT ITS (Florida Department of Transportation Intelligent Transportation System), one may click the "Roadway Camera" option, and a marker will appear at the location where every roadway camera (that is operated by that specific office). The ultimate goal of a user is to place markers exactly where one wishes to identify their points of interest. In the case of the example that will be used in this report, the points of interest are the cars that are photographed on the main channel span of the bridge (between the North and South Towers). To begin editing, go to the same list that houses the offices and click the last category

labeled “Basemap/Events Overview.” Here, choose the “Mouse Click Event (draggable)” option, as seen in Figure A-1. This will allow the user to place a temporary marker anywhere on the map by initially clicking on any point. By clicking the dropped marker, the pop-up will display the exact map coordinates of its location. It is helpful to copy/paste these locations for future reference. Additionally, if the marker does not appear exactly where desired, it can be dragged by clicking holding down a click and moving around with the mouse.

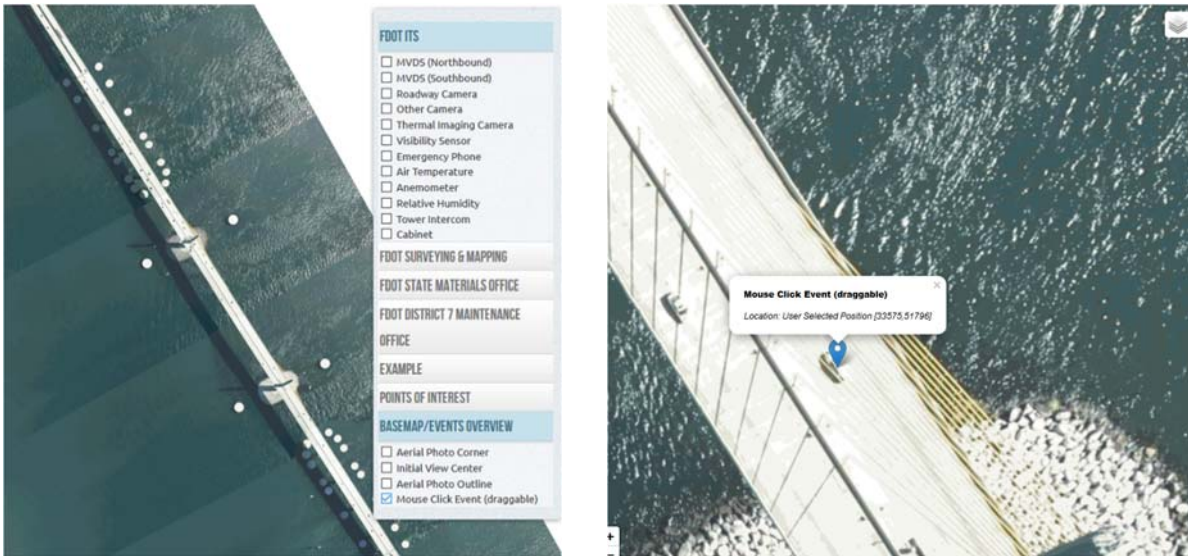

Figure A-1. Screen shot of “Mouse Click Event (draggable)” selection from the drop-down list (left) and screen shot of example resulting pop-up (right).

A1.2 Adding Markers through JavaScript Code

Now that the exact coordinates of each prospective marker are known, one can now edit the map through coding. The entire interactive map is based on the JavaScript code labeled “index” in the Mapping file in the inventory. To begin, right-click the file and choose “Edit.” This should open a program that allows the user to edit and save code; for the computer used in this example, the Notepad program opened the code file. Here, one will find several function that allows the user the input relevant data. These are as follows:

group_name='Name of Category of Items, usually the Office';

This allows the user to name the set of devices to be studied. For the cars, “EXAMPLE” was used, as reflected in Figure 1.

overlay_name = 'Name of Device';

This will be the name of the device, point of interest, etc. The user will click this option when they choose to see all the markers.

```
overlay_point_data = [];
```

Establishes that the following codes will add relevant markers.

```
overlay_point_data_add( [x coordinate, y coordinate], 'Location  
Supplement', 'identifier', ' description, using html formatted text', 'Image 1', 'Image 2' );
```

The most important function. It is here that the user will add all information regarding the specific point of interest.

```
create_overlay(overlay_point_data, simpleBlueMarker, overlay_name, group_name);
```

Add this line of code directly as typed. This closes off the lines of code for that device and adds the blue marker to the map.

It is useful to copy lines of code from any other category and trim or add for the certain batch of data. Starting from the three lines of back-slashes, highlight until the last `create_overlay` function is included, and paste under the last `create_overlay` function of another category. To keep the code readable, it is recommended to maintain the same line spacing and skipped line conventions. Look at the code in other locations to understand these formats. Additionally, always keep text between the ' ' symbols, as text will not display correctly if this is not adhered to. To add images to the map, either add an image from an external device or download one from the internet. Do not use spaces in the name; use underscores. The user must then save the image under the "Pictures" directory from the Inventory that the map is pulling its information from. Once this is done, add the image file name in the appropriate section of the `overlay_point_data_add` function. When all the coordinates, location information, identifiers, descriptions, and image file names are added correctly, the pop-up should be available for opening when the page is loaded in the browser. For the Cars example, a white car was chosen, so an image of a white car was added (which was taken from a Wikimedia Commons website). Additionally, since the car is located on the Main Channel Span of the bridge, this information was added alongside the coordinates in the "Location Supplement" part of the function; the pop-up will display this as the location.

After editing has been completed, click the index.html file in the inventory to open up the map. This map will reflect the changes that the user has made, and all changes will remain on the private (intranet) server. Be sure to save the code file whenever a change is made, as the changes will not appear in the map if this is not done. After this is done, refreshing the map will show all changes.

A1.3 Adding Polylines through JavaScript Code

Along with markers, the interactive map and coding provides the option of adding polylines to better explain certain areas or concepts. For example, the downloaded code highlights the Low Level Approach, High Level Approach, Main Span, and Main Channel Span so users can understand the specific vocabulary when referring to the Sunshine Skyway Bridge. The format for this coding is very similar to the one used for the markers, with some different functions:

```
overlay_line_data = [];
```

This allows the user to begin adding line data.

```
overlay_line_data_add( [ [x start, y start], [x end, y end] ] );
```

X and Y coordinates are used to establish at least two points to create a line. If the user wishes to add additional points, add a comma and begin bracketing additional coordinates (in order).

```
add_multiPolyline_to_overlay(overlay_line_data, 'color', overlay_name, group_name);
```

This ends the function. The only portion that can be changed is the color.

Each sub-category must still be listed under the overlay_name function and each sub-category must still be under a group_name. To identify the points that will be connected, use the draggable option marker from Figure A-1.

A2 Editing the Excel Inventory

All information that is present on the interactive map is mirrored by information that is stored on an excel sheet. It is up to the user's discretion as to how they wish to approach the use of the inventory; changing data in this file will not change anything in the map. However, for the sake of consistency and organization, it is advised that anything changed through the JavaScript code be changed on the excel sheet.

A2.1 Excel Sheet Organization

The excel sheet is organized using tabs which pertain to each office responsible for relevant equipment. In addition to the four tabs based on offices, there is a tab for general points of interest and a collection of all manuals in the database. For the example, an additional tab has been added that is called “Example.” In each tab, information is separated into different columns.

A2.2 Office and Points of Interest Tabs

The “Category” column describes what the item is in a broad stroke. From Traffic Detectors to Weather, this column broadly encapsulates what the device or point of interest represents. The “Item” column is where one can input exactly what the marker is referring to; this mirrors the overlay name. The “Type” column is merely extra information that seeks to refine what was described in the “Category” column. For an anemometer, the type would be “Sensor,” and so on. This is not on the code or map. Following “Type” are the “Location” and “Map Coordinates” columns which are directly taken from the Location Supplement and x and y coordinates from the code and map. The “Identifier” column allows the user to further describe location or a specific way to point out a certain marker, and this is also taken directly from the coding. Certain points of interest and devices are identified more easily through the use of these specific identifiers. “Manufacturer” and “Manufacturer Number” allows the user to narrow down the device further by adding the exact company that creates the device and the model that was created. This may be reflected in the description portion of the coding and the pop-up on the map. Now, each picture is described through a “Device”, “Filename”, “Hyperlink”, and “Date Taken” column. “Description” broadly explains what the user is seeing, “Filename” includes the exact filename of each photo from the database, “Hyperlink” provides a link to each photo from the inventory, and “Date Taken” states when each photo was taken. The subsequent tabs are unique to each office and may be edited to the preference of the user.

A2.3 Datasheets Tab

When the Inventory file is downloaded from the Web server, it includes a file that contains manuals and specification sheets for certain devices that are on the bridge. This allows for quick access to specific information on each device. If the user wishes to add a manual to their inventory, they should add certain information to this tab. The tab is separated into columns that are different than the ones used for the offices. The first column, “Device”, is the device described by its Manufacturer and Model. The following column, “Description”, allows for the user to elaborate on the office and general location of the device. A “Link” column contains direct Web links for each manual, while the “Hyperlink” column directly refers to the inventory located on the personal computer. The “Filename” refers to the filename of the document located in the inventory, while “Download Date” allows the user to state when each manual was downloaded. Subsequently, “Rev. Date” contains information pertaining to when each manual was revised by each manufacturer. To ensure that the manual is referring to the correct device, one may add a picture of the object. “Picture Filename”, “Picture Hyperlink”, and “Picture Date” all follow similar formats to the office tabs.

| | A | B | C | D | E | | F | G | H | I | J | K | | | L | M | N |
|----|----------|-----------------|------|-------------------|-----------------|-------|------------|----------|----------|-------------|-----------------------|-----------|------|------|--------|---|---|
| 1 | | | | | Map Coordinates | | | | | | | Picture 1 | | | | | |
| 2 | Category | Item | Type | Location | x | y | Identifier | Manufact | Manufact | Description | Filename | Hyperlink | Date | Take | Descri | | |
| 3 | Cars | Northbound Cars | | Main Channel Span | 33575 | 51796 | | White | | Vehicle | White_Car_Example.jpg | | | | | | |
| 4 | Cars | Northbound Cars | | Main Channel Span | 32728 | 50473 | | | | | | | | | | | |
| 5 | Cars | Northbound Cars | | Main Channel Span | | | | | | | | | | | | | |
| 6 | Cars | Northbound Cars | | Main Channel Span | | | | | | | | | | | | | |
| 7 | Cars | Northbound Cars | | Main Channel Span | | | | | | | | | | | | | |
| 8 | Cars | Northbound Cars | | Main Channel Span | | | | | | | | | | | | | |
| 9 | Cars | Northbound Cars | | Main Channel Span | | | | | | | | | | | | | |
| 10 | | | | | | | | | | | | | | | | | |
| 11 | Cars | Southbound Cars | | Main Channel Span | | | | | | | | | | | | | |
| 12 | Cars | Southbound Cars | | Main Channel Span | | | | | | | | | | | | | |
| 13 | Cars | Southbound Cars | | Main Channel Span | | | | | | | | | | | | | |
| 14 | Cars | Southbound Cars | | Main Channel Span | | | | | | | | | | | | | |
| 15 | | | | | | | | | | | | | | | | | |
| 16 | | | | | | | | | | | | | | | | | |
| 17 | | | | | | | | | | | | | | | | | |
| 18 | | | | | | | | | | | | | | | | | |
| 19 | | | | | | | | | | | | | | | | | |
| 20 | | | | | | | | | | | | | | | | | |
| 21 | | | | | | | | | | | | | | | | | |
| 22 | | | | | | | | | | | | | | | | | |
| 23 | | | | | | | | | | | | | | | | | |
| 24 | | | | | | | | | | | | | | | | | |
| 25 | | | | | | | | | | | | | | | | | |
| 26 | | | | | | | | | | | | | | | | | |
| 27 | | | | | | | | | | | | | | | | | |
| 28 | | | | | | | | | | | | | | | | | |
| 29 | | | | | | | | | | | | | | | | | |
| 30 | | | | | | | | | | | | | | | | | |
| 31 | | | | | | | | | | | | | | | | | |
| 32 | | | | | | | | | | | | | | | | | |
| 33 | | | | | | | | | | | | | | | | | |
| 34 | | | | | | | | | | | | | | | | | |
| 35 | | | | | | | | | | | | | | | | | |

Figure A-4. Modifications to the Excel Inventory showing how the Car Example would be added.

As seen in Figure A-4, the relevant information present in the coding and map from the Example are added to the specific columns as described in this report. The only difference lies with the manufacturer, as there was no specific manufacturer for the specified car. “White” is used instead.