

FINAL REPORT

Title: Testing Methods for the Next Generation of Concrete
FDOT Contract Number: BDV31-977-136

Submitted to

The Florida Department of Transportation Research Center
605 Suwannee Street, MS 30 Tallahassee, FL 32399

c/o Tim Ruelke
FDOT State Materials Office

Submitted by:

Dr. Christopher C. Ferraro (ferraro@ce.ufl.edu) (Principal Investigator)
Dr. Kyle A. Riding (Co-Principal Investigator)
Dr. Jerry M. Paris (Co-Principal Investigator)
Dr. Caitlin M. Tibbetts (Co-Principal Investigator)
Engineering School of Sustainable Infrastructure and Environment
University of Florida
Gainesville, Florida 32611

March 2021

Department of Civil Engineering

Engineering School of Sustainable Infrastructure and Environment

College of Engineering

DISCLAIMER

The opinions, findings, and conclusions expressed in this publication are those of the authors and not necessarily those of the State of Florida Department of Transportation or the U.S. Department of Transportation.

Prepared in cooperation with the State of Florida Department of Transportation and the U.S. Department of Transportation.

SI (MODERN METRIC) CONVERSION FACTORS (FROM FHWA)

Symbol	When You Know	Multiply By	To Find	Symbol
Length				
in	inches	25.4	millimeters	mm
ft	feet	0.305	meters	m
yd	yards	0.914	meters	m
mi	miles	1.61	kilometers	km
Area				
in²	square inches	645.2	square millimeters	mm ²
ft²	square feet	0.093	square meters	m ²
yd²	square yard	0.836	square meters	m ²
mi²	square miles	2.59	square kilometers	km ²
Volume				
fl oz	fluid ounces	29.57	milliliters	mL
gal	gallons	3.785	liters	L
ft³	cubic feet	0.028	cubic meters	m ³
yd³	cubic yards	0.765	cubic meters	m ³
NOTE: volumes greater than 1000 L shall be shown in m³				
Mass				
oz	ounces	28.35	grams	g
lb	pounds	0.454	kilograms	kg
Temperature (exact degrees)				
°F	Fahrenheit	5 (F-32)/9 or (F-32)/1.8	Celsius	°C
Illumination				
fc	foot-candles	10.76	lux	lx
fl	foot-Lamberts	3.426	candela/m ²	cd/m ²
Force and Pressure or Stress				
lbf	pound-force	4.45	newtons	N
lbf/in²	pound-force per square inch	6.89	kilopascals	kPa

TECHNICAL REPORT DOCUMENTATION

1. Report No.	2. Government Accession No.	3. Recipient's Catalog No.	
4. Title and Subtitle Testing Methods for the Next Generation of Concrete		5. Report Date February 2021	
		6. Performing Organization Code	
7. Author(s) Christopher C. Ferraro, Kyle A. Riding, Jerry M. Paris, Caitlin M. Tibbetts		8. Performing Organization Report No.	
9. Performing Organization Name and Address Department of Civil and Coastal Engineering Engineering School of Sustainable Infrastructure & Environment University of Florida 365 Weil Hall P.O. Box 116580 Gainesville, FL 32611-6580		10. Work Unit No.	
		11. Contract or Grant No. BDV31-977-136	
12. Sponsoring Agency Name and Address Florida Department of Transportation 605 Suwannee Street, MS 30 Tallahassee, FL 32399		13. Type of Report and Period Covered Draft Final Report September 2020 – February 2021	
		14. Sponsoring Agency Code	
15. Supplementary Notes – N/A			
16. Abstract <p>The Florida Department of Transportation is working towards the evaluation of structural portland cement concrete to ensure the service life requirements for concrete structures are met based on material performance. As the industry moves toward performance specifications, there is a need to evaluate the performance of the composite concrete sample, rather than the individual components. Therefore, the objective of this project was to perform a thorough literature review to determine if there are existing test methods that can quantify the performance of concrete with respect to heat evolution, cracking, and durability at the mix design phase. Based upon the exhaustive literature search performed, there are a large number of tests available to evaluate composite concrete specimens for heat evolution, cracking potential, and durability. The majority of these test methods did not meet the criteria of FDOT without any modifications; the few methods that met all of the qualifications do not provide sufficient information to be recommended for FDOT quality assurance/quality control (QA/QC). Recommendations for a future study to investigate these methods further and determine acceptance criteria is as follows. To evaluate potential for cracking of concrete, a Florida Method based on AASHTO T 334 should be created. Additionally, a Florida Method based on the LCPC QAB semi-adiabatic calorimetry test should be developed to measure heat evolution of concrete. Lastly, characteristics regarding chloride and sulfate durability require fundamental research into the accelerated curing regimes, especially for concrete using SCMs prior to a Florida Method being developed to assess these characteristics.</p>			
17. Key Word Concrete, heat generation, cracking, chloride, sulfate, durability, transport property		18. Distribution Statement No restrictions.	
19. Security Classif. (of this report) Unclassified.	20. Security Classif. (of this page) Unclassified.	21. No. of Pages 121	22. Price

ACKNOWLEDGEMENTS

The Florida Department of Transportation (FDOT) is acknowledged for their funding and contributions to this study.

EXECUTIVE SUMMARY

Background

The Florida Department of Transportation is working towards the rapid evaluation and qualification of portland cement concrete to ensure the service life requirements for structures are met based on material performance. As the industry moves toward performance specifications, there is a need to evaluate the performance of the composite concrete sample, rather than the individual components. Therefore, the objective of this project was to perform a thorough literature review to determine if there are existing test methods that can quantify the performance of concrete with respect to heat evolution, cracking, and durability at the mix design phase. Test methods were evaluated based on the following criteria:

- Testing will be conducted on conventional portland cement concrete – not mixture components, derivatives, or specialty mixes (e.g., paste, mortar, grout, UHPC, RCC).
- The time for completion does not exceed 30 days for testing.
- The testing techniques do not utilize any hazardous materials.
- Tests are relatively uncomplicated – a person with a high-school education can perform.
- Cost of testing equipment should support a wide deployment – total cost not to exceed \$30,000.00.

The project reviewed the available literature related to testing of concrete to assess potential for excessive shrinkage, potential to experience excessive temperature rise, and chloride and sulfate durability. The research team categorized identified test methods into categories as follows:

- Category I – Test meets current needs of FDOT without any modifications.
- Category II – Test can be modified to successfully meet FDOT needs.
- Category III – Test shows some potential to meet FDOT needs, but does not meet one of the main criteria listed above.

Main Findings

Based upon the exhaustive literature search performed, there are a large number of tests available to evaluate composite concrete specimens for heat evolution, cracking potential, and durability. The majority of these test methods did not meet the criteria of FDOT without any modifications; the few methods that met all of the qualifications do not provide sufficient information to be recommended for FDOT quality assurance/quality control (QA/QC).

Research Significance

There are a large number of test methods that have been developed over the last 100 years for determining heat evolution, cracking, and durability; however, there is not a standard testing regimen that meets the criteria outlined above. Modifications of existing standards and development of new methods could provide expedient qualification of concrete mixtures, if these new methods prove effective.

Conclusions

Based on the literature reviewed, the following conclusions were drawn from this study:

- The best available testing method for determining cracking is the Standard Method of Test for Estimating Cracking Tendency of Concrete as per AASHTO T 334. The method has a provision that allows for a standard size pipe to be used to construct the mold; if this provision is disallowed (or the rest of the mold is made bigger) to allow a 3-in. minimum specimen thickness, this specification would meet all of the FDOT criteria.
- The best available testing method for determining the heat production and resultant temperature rise of concrete is the LCPC QAB semi-adiabatic calorimetry test method. The test provides the most robust data due to the large specimen size; however, modifications to allow for larger sizes would need to be developed prior to full adoption by FDOT.
- The chloride and sulfate durability testing methods require further evaluation and development prior to being accepted with FDOT criteria; the largest barrier to acceptance is the 30-day requirement in combination with the ability to test concrete mixes with supplementary cementitious materials.
- Some of the standard testing methods summarized in Table 39 may meet all of the FDOT criteria but do not give adequate testing information based on the available literature.
 - Methods for semi-adiabatic heat rise meet all of the criteria, but the data obtained are insufficient for a quality control program.
 - Methods regarding unrestrained shrinkage similarly meet FDOT requirements, but the amount of information is limited to one or two forms of shrinkage, and is not directly applicable to reinforced or restrained scenarios, which comprise the majority of FDOT applications.

Recommendations

Based upon the findings from this study, the following recommendations are made:

- Develop and create precision statement for a Florida Method based on AASHTO T 334 that does not allow for a standard size pipe to be used to construct the mold; using a standard size pipe restricts the specimen size and thus the maximum aggregate size.
- Develop and create precision statement for a Florida Method based on the LCPC QAB semi-adiabatic calorimetry test method to allow for larger specimen sizes to ensure QA/QC at the design mix stage.
- For chloride and sulfate durability, fundamental research into the evaluation of accelerated curing regimes is required, especially for concrete using SCMs.
 - Further research should include investigation of the standard and accelerated curing methods prescribed in the Standard Practice for Developing Engineered Concrete Pavement Mixtures (AASHTO PP 84) for the acceptance of FDOT concrete. Currently, there is active research being performed with regards to accelerated curing methods as prescribed the Standard Test Method for Electrical Resistivity of a Concrete Cylinder Tested in a Uniaxial Resistance Test

(AASHTO TP 119) and the Standard Method of Test for Determining the Pore Volume in Hardened Concrete Using Vacuum Saturation (AASHTO TP 135).

Benefits to the State

The literature review provides guidance for the rapid and robust qualification of concrete mixtures for FDOT-owned structures. This includes guidance with respect to the development of Florida Methods based on the test methods investigated for heat evolution, cracking potential, and durability. Modifications of existing standards and development of new methods provide a pathway towards the expedient qualification of concrete mixtures, especially those utilizing supplementary cementitious materials, if proven effective. Rapid and robust testing methods are critical for the efficient qualification of concrete mixtures, which ultimately leads to reduced repair and maintenance costs FDOT-owned structures.

TABLE OF CONTENTS

DISCLAIMER	ii
SI (MODERN METRIC) CONVERSION FACTORS (FROM FHWA)	iii
TECHNICAL REPORT DOCUMENTATION	iv
ACKNOWLEDGEMENTS	v
EXECUTIVE SUMMARY	vi
LIST OF FIGURES	xii
LIST OF TABLES	xiv
1. INTRODUCTION	1
1.1. BACKGROUND.....	1
1.2. RESEARCH OBJECTIVES	2
1.3. RESEARCH APPROACH.....	3
2. HEAT EVOLUTION TESTING	4
2.1. BACKGROUND.....	4
2.1.1. Adiabatic Temperature Measurement.....	5
2.1.2. Semi-Adiabatic Temperature Measurement	5
2.1.3. Isothermal Temperature Measurement	6
2.2. ADIABATIC TEST METHODS.....	7
2.2.1. USBR Method.....	7
2.2.2. RILEM Method.....	9
2.2.3. CRD-C Method.....	11
2.2.4. EN 12390 – Part 15.....	14
2.2.5. Existing Available Equipment	15
2.3. SEMI-ADIABATIC TEST METHODS	16
2.3.1. RILEM Method.....	16
2.3.2. LCPC QAB.....	19
2.3.3. NT Build 388	21
2.3.4. EN 12390 – Part 14.....	23
2.3.5. ASTM C1753.....	23
2.3.6. Existing Available Equipment	24
2.4. ISOTHERMAL TEST METHODS	25
2.4.1. ASTM C1679.....	25
2.4.2. Existing Available Equipment	26

2.5.	SUMMARY	27
3.	CRACKING TENDENCY TESTING	28
3.1.	BACKGROUND.....	28
3.2.	RESTRAINED SHRINKAGE.....	30
3.2.1.	ASTM C1581	31
3.2.2.	AASHTO T 334.....	33
3.2.3.	AASHTO T 363.....	36
3.2.4.	Cracking Frame.....	38
3.2.5.	NT Build 433	41
3.2.6.	ASTM C1579.....	43
3.3.	UNRESTRAINED SHRINKAGE	46
3.3.1.	ASTM C157/AASHTO T 160	46
3.3.2.	EN12390 – Part 16.....	47
3.3.3.	AASHTO T 336.....	48
3.3.4.	ASTM C827.....	50
3.3.5.	Existing Available Equipment	52
3.4.	OTHER METHODS	52
3.4.1.	German Angle Test.....	52
3.4.2.	SPS Plate Test.....	53
3.4.3.	ASTM C596.....	53
3.4.4.	ASTM C1090.....	54
3.5.	SUMMARY	54
4.	DURABILITY TESTING	55
4.1.	BACKGROUND.....	55
4.1.1.	Chloride Durability.....	56
4.1.2.	Sulfate Durability.....	57
4.2.	CHLORIDE DURABILITY	58
4.2.1.	ASTM C1202/AASHTO T 277	58
4.2.2.	NT Build 492	62
4.2.3.	AASHTO T 358.....	65
4.2.4.	AASHTO TP 119.....	67
4.2.5.	Chloride Binding.....	70
4.2.6.	Existing Available Equipment	70

4.3.	SULFATE DURABILITY	71
4.3.1.	USBR 4908	71
4.3.2.	MNS Test	73
4.3.3.	Soaking and Drying Test	74
4.3.4.	Rapid Sulfate Electrochemical Test	76
4.3.5.	Partial Immersion	78
4.3.6.	Complete Immersion	79
4.4.	TRANSPORT PROPERTY	81
4.4.1.	AASHTO PP 84	81
4.4.2.	EN 12390 – Part 8/CRD-C 48-92/ACCI water permeability	83
4.4.3.	ASTM C1585	87
4.4.4.	ASTM C642	88
4.5.	SUMMARY	89
5.	MAIN FINDINGS, CONCLUSIONS, AND RECOMMENDATIONS	91
5.1.	MAIN FINDINGS	91
5.2.	CONCLUSIONS	94
5.3.	RECOMMENDATIONS	95
	REFERENCES	96

LIST OF FIGURES

Figure 1. General diagram of adiabatic calorimeter design adapted from RILEM TC 119.	10
Figure 2. Plan view of insulated concrete specimen with location of RTDs per CRD-C 36-73. .	12
Figure 3. Sure Cure system with the computer, hydration chamber, and controller box by Products Engineering, Inc. [6].	16
Figure 4. Example of semi-adiabatic measuring device from RILEM TC 119-TCE.....	17
Figure 5. Example of semi-adiabatic measuring device used for LCPC QAB.....	19
Figure 6. Differences in maximum heat generation between an effectively uninsulated and well-insulated concrete specimen [19].....	23
Figure 7. Relationship between autogenous and chemical shrinkage, adapted from [29].....	29
Figure 8. General diagram of a concrete ring cracking test.....	31
Figure 9. Ring test setup for ASTM C1581.....	31
Figure 10. Initial layout of dual-ring test from AASHTO T 363.....	37
Figure 11. General testing setup for concrete cracking frame.....	38
Figure 12. Typical plot of cracking frame stress development with time and temperature.....	39
Figure 13. Typical plot of cracking frame stress development with time and temperature.....	41
Figure 14. Concrete panel mold specifications. Adapted from ASTM C1579.....	43
Figure 15. Example of a specimen cabinet that must be inside an environmental chamber to test two concrete panels in accordance with ASTM C1579.....	44
Figure 16. Schematic of a CTE setup as per AASHTO T 336.	49
Figure 17. Test setup for ASTM C827.	51
Figure 18. German angle test.....	53
Figure 19. SPS plate test setup.....	53
Figure 20. Diagram of ASTM C1202/ AASHTO T 277 specimen cell setup with rubber gaskets.	59
Figure 21. Picture of PROOVEit voltage application and data readout apparatus used for ASTM C1202/AASHTO T 277 and NT Build 492.	62

Figure 22. Diagram of NT Build 492 test setup [86].	63
Figure 23. Diagram of four-point Wenner probe for surface resistivity test setup.	65
Figure 25. Diagram of bulk resistivity test setup.	67
Figure 24. Picture of Resipod surface resistivity apparatus by Proceq for AASHTO T 358.	70
Figure 26. Diagram of typical casting mold used for USBR 4908 specimens.	71
Figure 27. Comparison of w/cm to residual compressive strength, data from [108]. Control mixes have no SCM.	76
Figure 28. Diagram of unsealed specimen for water penetration depth test per EN 12390-8 [118].	84
Figure 29. Diagram of water permeability test assembly for CRD-C 48-92 [120].	85
Figure 30. Diagram of University of Florida water permeability cell with concrete specimen cast in epoxy ring (similar to the ACCI water permeability test).	86
Figure 31. Diagram of partial water exposure for water absorption test ASTM C1585 [127].	87

LIST OF TABLES

Table 1. Summary of required equipment and approximate costs using USBR 4911-92.	8
Table 2. Summary of required equipment and approximate costs using RILEM TC 119-TCE. .	10
Table 3. Differences between CRD-C 38-73 and USBR 4911.....	13
Table 4. Summary of required equipment and approximate costs using CRD-C 38-73.	14
Table 5. Summary of required equipment and approximate costs using RILEM TC 119-TCE. .	18
Table 6. Summary of required equipment and approximate costs using LCPC QAB.	20
Table 7. Summary of required equipment and approximate costs using NT Build 388.....	22
Table 8. Summary of criteria for heat evolution test methods.....	28
Table 9. Potential for cracking classification adapted from ASTM C1581.....	32
Table 10. Summary of required equipment and approximate costs using ASTM C1581.	33
Table 11. Summary of technical differences between ASTM C1581 and AASHTO T 334.....	34
Table 12. Summary of required equipment and approximate costs using AASHTO T 334.	35
Table 13. Summary of required equipment and approximate costs using AASHTO T 363 assuming one specimen is tested at a time rather than three.....	37
Table 14. Summary of required equipment and approximate costs using a basic cracking frame.	40
Table 15. Summary of required equipment and approximate costs using NT Build 443 with three specimens.....	42
Table 16. Summary of required equipment and approximate costs using ASTM C1579.	45
Table 17. Summary of required equipment and approximate costs using ASTM C157 or AASHTO T 160 with six specimens.	47
Table 18. Summary of required equipment and approximate costs using AASHTO T 336.	50
Table 19. Summary of required equipment and approximate costs using ASTM C827.	51
Table 20. Summary of criteria for cracking test methods.....	55
Table 21. Chloride ion penetrability classifications per ASTM C1202 / AASHTO T 277 [80], [81].....	58

Table 22. Summary of required equipment and approximate costs using ASTM C1202 / AASHTO T 277 ¹	60
Table 23. Summary of required equipment and approximate costs using NT Build 492.....	64
Table 24. AASHTO T 358 chloride ion penetrability classifications based on surface resistivity values for 4 in. x 8 in. and 6 in. x 12 in. cylinders [87].	66
Table 25. Summary of required equipment and approximate costs using AASHTO T 358.	66
Table 26. AASHTO TP 119 chloride ion penetrability based on uniaxial (bulk) resistivity values [95]......	68
Table 27. Summary of required equipment and approximate costs using AASHTO TP 119.	69
Table 28. Summary of required equipment and approximate costs using USBR 4908.	72
Table 29. Summary of required equipment and approximate costs using the MNS test.....	73
Table 30. Summary of required equipment and approximate costs using the soaking and drying test (four – 2-in. cubes soaked, four 2-in. cubes not soaked, three – 6-in. cubes compression)...	75
Table 31. Summary of required equipment and approximate costs using the rapid sulfate electrochemical test.....	77
Table 32. Summary of required equipment and approximate costs using the partial immersion sulfate exposure of concrete specimens proposed by Hartell et al. [78].....	79
Table 33. Summary of required equipment and approximate costs using the complete immersion sulfate exposure of concrete specimens proposed by Park et al. [110].	81
Table 34. Summary of required equipment and approximate costs using the formation factor per AASHTO PP 84 ¹	82
Table 35. Summary of required equipment and approximate costs using water permeability test methods.	86
Table 36. Summary of required equipment and approximate costs using ASTM C1585.	88
Table 37. Summary of required equipment and approximate costs using ASTM C642.	89
Table 38. Summary of criteria for durability test methods.	90
Table 39. Summary table of test methods and FDOT category classification.....	91
Table 40. Final summary table of experimental methods.....	93

1. INTRODUCTION

1.1. BACKGROUND

The Florida Department of Transportation (FDOT) is working towards the evaluation of cracking of portland cement concrete for use in FDOT-owned structures. Accordingly, the assessment of concrete at the design and qualification stages is needed to ensure the service life requirements for concrete structures are met based on material performance. There are a myriad of different test methods used to evaluate the components of concrete, which are intended for specifications that are mostly prescriptive in nature. However, as the industry moves toward performance specifications, there is a need to evaluate the performance of the composite concrete sample, rather than the individual components.

Early age shrinkage of concrete is a consequence of hydration wherein the initial volume of concrete is greater than the final volume of concrete as the concrete transitions from a plastic to an elastic material. This is generally known as “autogenous shrinkage” in hardened concrete where exterior water is unable to migrate towards the inner pore structure, and which is understood to occur without being subjected to external forces and under constant temperature [1]. Additionally, when evaporation of water from fresh concrete happens faster than the water can proceed to the surface through “bleeding”, “plastic shrinkage” will result and begin to produce inner tensile forces on the concrete before set. In either scenario, cracking may occur, resulting in immediately reduced durability through increased susceptibility to sulfate, chloride, and water ingress.

Concrete structures are adversely affected by chlorides and sulfates which may be present during mixing, borne from environmental exposure, or a combination of both conditions. With respect to sulfate degradation, internal sulfate attack (concrete degradation associated with sulfates present during mixing) is typically associated with high curing temperatures and dissolution of ettringite, forming monosulfate, which then latter reverts to ettringite forming needle-like crystals inside pores, inducing tensile forces. External sulfate exposure can result in more than one degradation mechanism. Damage to the cement paste through crystallization pressure (thenardite and mirabilite phase change) is also known as “physical salt attack” [2]. Whereas chemical degradation in which sulfate-bearing soils or water chemically dissolve cement hydrates (predominantly calcium aluminate phases) and form less soluble phases can produce expansive forces on the hardened paste [3]. Additionally, thaumasite can form as a conversion of ettringite (a normal byproduct of hydration) when exposed to carbonate from the atmosphere, from limestone aggregates within the concrete, or from carbonate soils that the concrete is in contact with.

The presence of chlorides in a cementitious system is generally broken into two main categories: water-soluble (or available) chloride, and acid-soluble (or total) chloride. It is a general agreement that only water-soluble chlorides present within a cementitious system during hydration are able to freely move throughout the pore fluid system. The remaining chlorides present are considered to be “bound” within inaccessible phases and pose less likelihood for damage. In Florida, chlorides are a common concern for structures near marine environments where water-borne or air-borne chlorides produce a damage mechanism by external chloride

attack. The main concern with either chloride origination is damage to the concrete structure due to the corrosion of reinforcing steel as the corrosion product of steel is approximately seven times more voluminous than the original steel itself.

The hydration of portland cement is an exothermic chemical reaction, where excessive heat generation can result in a number of durability concerns. As discussed previously, internal sulfate attack (also referred to as “delayed ettringite formation”) is considerably more likely to result in cracking of concrete when the concrete experiences temperatures exceeding 158°F (70°C) and the magnitude of deleterious expansion is exacerbated by continued thermal heat rise [4]–[6]. Due to the nature of the exothermic reactions, increased heat rise tends to make the hydration of portland cement accelerate; combined with thermal expansion of the concrete mass and the rate of thermal emissivity, this can differential stress internally in hydrating concrete where the inner core of the placement is considerably hotter, more hydrated (and therefore less plastic) while the outer surfaces can radiate heat away (leading to less maturity and higher likelihood of cracking) [7]. These compounding factors are more pronounced in placements with large volumes with relatively small exposed surface areas (predominantly drilled shafts, large footings, and bridge superstructure elements) collectively known as “mass” or “thermally controlled” concrete. These particular elements necessitate the use of additional control systems (temperature monitoring, thermal modeling for mixture design, precooled aggregates, post-cooled circulating water in embedded pipes, etc.) [8], [9].

With all of these concerns, various methods can be employed to mitigate or eliminate the likelihood of damage. The methods of mitigation often vary, but some methods such as the addition of supplementary cementitious materials such as fly ash or silica fume can result in reduction of potential for damage from multiple degradation mechanisms. However, the implementation of these materials also further complicate evaluation of performance due to their longer time to maturity.

1.2. RESEARCH OBJECTIVES

The objective of this project is to perform a thorough literature review to determine the existence of test methods that can qualify the performance of a portland cement concrete mixture with respect to cracking, durability and heat generation at the mix design phase. Preference will be given to test methods based on the following criteria:

- Testing will be conducted on conventional portland cement concrete containing coarse aggregate – not mixture components, derivatives, or specialty mixes (e.g., paste, mortar, grout, UHPC, RCC)
- The time for completion of testing does not exceed 30 days from casting
- The testing techniques do not utilize any hazardous materials
- Tests are relatively uncomplicated – a person with a high-school education can perform
- Cost of testing equipment should support a wide deployment – total cost not to exceed \$30,000.00

The project reviewed the available literature related to testing of concrete to assess potential for excessive shrinkage, potential to experience excessive temperature rise, and chloride and sulfate durability. The research team will categorize any successfully identified test methods into categories as follows:

- Category I – Test method meets current needs of FDOT without any modifications.
- Category II – Test method can be modified to successfully meet FDOT needs.
- Category III – Test shows some potential to meet FDOT needs, but does not meet one of the main criteria listed above.

1.3. RESEARCH APPROACH

The research approach included a literature review of existing test methods that can quantify the performance of concrete with respect to heat evolution, cracking, and durability at the mix design phase. Chapter 2 documents the test methods found in the literature for heat evolution for adiabatic, semi-adiabatic, and isothermal calorimetric testing. Chapter 3 discusses restrained and unrestrained shrinkage test methods to evaluate the potential for cracking. Chapter 4 chronicles durability test methods with respect to chloride and sulfate penetrability as well as general transport characteristics. The five criteria outlined in the Research Objectives are summarized for each test method and then categorized based on the FDOT needs. Chapter 5 presents the conclusions and recommendations based on the findings herein.

2. HEAT EVOLUTION TESTING

2.1. BACKGROUND

Portland cement concrete is composed of a variety of materials that can be grouped as aggregates, water, reinforcement (whether it be steel reinforcement or fiber reinforcement), and cementitious/binder material. The aggregate, water, and reinforcement portions of the composition do not take part in hydration chemical reactions and therefore the cementitious content is responsible for the entirety of the heat generation of a concrete mix (ignoring environmental and initial conditions).

The hydration reaction of portland cement and water is exothermic in nature and therefore will produce heat as the hydration proceeds [1], [2]. This chemical reaction also tends to accelerate with thermal input [3, p. 207], and as concrete can be a thermal insulator, this can result in concrete self-insulating causing higher temperatures and accelerated hydration. In an unchecked situation, this can result in temperatures exceeding 200°F (93°C), and thermal cracking of the concrete element.

The factors that affect the heat evolution of a concrete mixture include cementitious material type and content, material fineness, material chemistry, initial placement/reaction temperature, water-to-binder ratio, and the thermal properties of the concrete constituents, amongst other factors. The heat rise of concrete directly impacts the rate of strength gain, form removal, thermal gradients, and can influence the cracking and durability. Higher temperatures generally result in higher early compressive strengths (but lower ultimate strengths), which allow for faster removal of formwork. However, hydrating cement exposed high temperatures typically results in less dense phase assemblages to form causing higher permeability and lead to reduced service life when chloride and sulfate exposure are concerns. Unregulated thermal rise in concrete can lead to high thermal gradients in which interior portions of concrete placements are much higher temperatures than exterior surfaces [2]. This differential temperature causes a thermal expansion incompatibility wherein the interior portions expand beyond what the exterior strength allows for, resulting in tensile stresses to develop to a point where the concrete cracks. These cracks considerably reduce the service life of concrete by allowing accelerated ingress of deleterious substances.

Evaluating the heat rise of concrete must strive to standardize as many external variables as possible to gauge a concrete mix purely on the mixture composition rather than factors such as environmental wind/precipitation loading, insulation level, size/shape of placement, initial/transient temperature differentials, or any compounding factors that would influence the final placement temperature. Most measurement methods attain this by constraining the initial temperature conditions, the sample size and shape, level of insulation, and prevention of moisture loss in an effort to seal the system from external variables. With all constraints in place, the only variables remaining are the mixture components themselves; therefore, the resulting heat given off is characteristic of the mixture composition.

2.1.1. Adiabatic Temperature Measurement

The measurement of the total heat of the concrete mixture components, given an initial temperature, constant specimen shape and size, without loss or gain of temperature to the environment is known as the adiabatic temperature rise of concrete. The technical definition of adiabatic is “a condition in which heat neither enters or leaves the system” [4]. RILEM Technical Committee 119-TCE defines an adiabatic calorimeter as one that prevents the specimen from having a maximum temperature loss of 0.02 K/hr [5]. This is the maximum heat rise that can be attained from a concrete mixture given the initial conditions with no external factors. In practice, perfectly adiabatic conditions are essentially impossible to attain; however, very close approximations are performed by measuring the heat evolved by concrete and adjusting the environmental temperature to match.

Adiabatic temperature rise measurement has significant drawbacks and potential pitfalls due to the nature and precision of the measurements. Since the device must have a maximum temperature loss of 0.02 K/hr, active heating and cooling systems are required to maintain environmental conditions. Furthermore, as the chemical hydration reactions are affected by temperature, having systemic errors in environmental temperature will result in erroneous results [6]. This necessitates highly calibrated temperature sensors and tightly controlled heating and cooling systems that do not over heat or over cool the system, which would affect the reaction. One method to ease the temperature sensitivity is using large specimens, sometimes exceeding 1 yd³ (as they are less susceptible to temperature swings from the environment); but this requires large curing spaces, heating and cooling systems, mixers, molds, and specimen handling equipment. All of these modifications translate into higher initial and “per test” costs. While larger specimens are not strictly necessary, it has been shown that smaller specimens generally result in lower evolved heat when using commercially available equipment [7].

Despite the drawbacks, a properly conducted adiabatic temperature rise measurement will result in quite accurate hydration curves. RILEM recommends the use of adiabatic calorimeters in situations where high degrees of accuracy are required, or when attempting to simulate conditions that approximate adiabatic conditions such as in mass concrete placements where the majority of concrete is self-insulated [5].

2.1.2. Semi-Adiabatic Temperature Measurement

A method of measurement that typically requires less experimentation set up, involves placing a specimen into a well-insulated container and measuring the heat evolved over time without adjusting the temperature of the environment. Consequently, some amount of heat energy is lost to the environment as a tradeoff for lower cost of experimentation. This method is known as semi-adiabatic temperature rise because heat loss/gain is minimized, however, active systems are usually not in place to assure that the heat remains constant. RILEM TC 119-TCE defines a semi-adiabatic calorimeter as a calorimeter that has a maximum heat loss that is less than 100 J/(hr-K) [5].

One of the major benefits to the semi-adiabatic temperature rise measurement is that there are several variants of “off-the-shelf” calorimeters that can be purchased to measure the heat evolved from concrete specimens. One of downsides is that the sample size is generally a 4 in. x 8 in.

cylinder, which is considered to be a small sample of concrete as true adiabatic temperature rise of concrete is dependent on size. As a result, using a small specimen size could result in large variability, especially with extended measurements as the total heat output is low. However, semi-adiabatic calorimeters can be fabricated to house specimens of any size by using large amounts of insulation. This comes with the same mixing and handling issues as the larger adiabatic testing, but will not require large air conditioning systems to match the temperature, making it less expensive.

Additionally, several semi-adiabatic calorimeters that are available off-the-shelf have the capability to test more than one specimen at a time. While this may seem advantageous, there is a concern for “thermal crosstalk” where a sensor will detect heat from a neighboring specimen erroneously. Furthermore, even with multiple testing channels, the calorimeter should not be opened while a test is in progress; therefore, the number of channels available for use is limited to the number of concrete mixes or specimens that will be tested for the same duration.

The largest detraction from semi-adiabatic calorimetry is that the data has to be converted from semi-adiabatic heat rise to an approximated adiabatic heat rise. Due to this approximation, relaxation in specimen insulation and heat measurement are often employed leading to considerably reduced costs, but the data obtained is not “true” adiabatic heat rise.

2.1.3. Isothermal Temperature Measurement

Isothermal temperature measurement involves the determination of the heat of evolution of the chemical reaction of a mass of cement paste, mortar, or concrete under constant temperature. According to ASTM C1679 (primarily used for cementitious paste experiments), samples are placed into an isothermal calorimeter, which measures heat flow from a specimen maintained at a constant temperature by intimate thermal contact with a constant temperature heat sink [8]. The heat moving through the sensor is recorded as thermal power, which is plotted as a function of hydration, providing an indication of the rate of hydration over time at a given temperature [8]. Isothermal calorimetry is almost universally utilized for cementitious pastes and mortars; however, there are some companies that offer calorimeters with cells for concrete.

With isothermal testing, the specimen is meant to remain at a constant temperature which is in stark contrast to the previous two test methods that measure the increase in specimen temperature. To maintain constant temperature, the heat energy must theoretically be removed as soon as it is created, but also simultaneously measured. The majority of isothermal calorimeters rely on a single directional thermal sensor (below the specimen) to record temperature, and therefore, some heat is lost to the calorimeter through the sides or top of the specimen. This effect is amplified for larger samples such as concrete. Similar to the multi-channel semi-adiabatic chambers, isothermal chambers will usually have more than one channel so crosstalk is also a concern with these experiments. The most common off-the-shelf isothermal calorimeters have specimen capacities of approximately 7.5 in³ (0.125 L) whereas a 4 in. x 8 in. cylinder is approximately 100 in³ (1.64 L). This sample size restriction would limit the aggregate size required to get a representative sample.

2.2. ADIABATIC TEST METHODS

2.2.1. USBR Method

The United States Bureau of Reclamation (USBR) developed a method of measuring the adiabatic temperature rise of concrete. This method, simply called “Procedure For Temperature Rise of Concrete” is designated as procedure USBR 4911-92 [9]. In summary, the test involves a cylindrical specimen of concrete having dimensions of 21.5 in. dia. x 21.5 in. tall and approximate 700 lb that is placed into a well-insulated calorimeter wherein an electrical resistance thermometer (resistance temperature device, RTD) is embedded into the specimen to measure temperature. This calorimeter is placed into a room where the temperature of the air is maintained to be the same temperature as the concrete specimen; as the cementitious materials react and produce heat, the RTD measures the temperature and relays the information to the air temperature controller which adjusts the temperature of the room. When no specimens are present in the room, the temperature control box shall maintain the room temperature at 70°F (21.1°C).

This method requires the concrete mold to be 21.5 in. dia. by 21.5 in. tall, made of 20-gauge “black iron”, with a 7 in. hole in the top for filling the mold in two layers in a manner such that exact quantities are known.

Note: The term “black iron” does not designate a specific grade of metal; colloquially black iron is used in piping to indicate a pipe that is coated with a lacquer paint to prevent corrosion. However, ASTM A123 – *Standard Specification for Zinc (Hot-Dip Galvanized) Coatings on Iron and Steel Products* defines “black” as “the condition of not galvanized or otherwise coated. For purposes of this specification the word ‘black’ does not refer to the color or condition of surface, or to a surface deposit or contamination” [10]. It should be noted that this specification may be recommending the use of “black plate” which is low-carbon steel, however, this material is noted in ASTM A625 as being “highly susceptible to rusting” and ASTM A650 notes that it is “relatively brittle” but both specifications note its use for can bodies [11], [12]. Additionally, there are a number of manufacturers in the US that supply black plate in thicknesses up to 20-gauge.

The lid must have two 12 in. long brass tubes soldered through the lid extending into the container which will house temperature measuring devices. Additionally, an air valve is soldered on the lid so the container can be pressurized to 2 - 3 inHg to ensure that the container is air-tight. Optionally, a manometer is also soldered to the lid to allow the study of pressure development during hydration.

Once sealed, oil is added to each thermometer well to act as a heat transfer fluid between the brass tubes in the specimen and the temperature measuring devices. A control thermometer (or RTD) is immediately placed in one of the wells and connected to the temperature controller of the room so that the room temperature will match the specimen temperature. In the second well, a second thermometer is placed and read to ensure that the air temperature of the room is the same temperature of the specimen; if not, adjustments to the temperature controller (temperature offsets) must be made.

Temperature readings are then taken at hourly intervals at the beginning of the test with increasingly greater intervals as the test progresses. Temperature monitoring should continue for a minimum of 28 days and the values of temperature rise and heat of hydration of cementitious material should be reported at 1, 3, 7, 14, and 28 days. Table 1 provides a summary of the approximate costs to run the USBR 4911-92 adiabatic test method for one sample.

Table 1. Summary of required equipment and approximate costs using USBR 4911-92.

Non-Consumables – Approximate Cost		Consumables – Approximate Cost		
<ul style="list-style-type: none"> • Ultra-precise temperature sensor – \$1,000 (similar to Honeywell Type R4 or R6 RTD; if these do not meet specifications, Correge Sensors can custom make probes to desired specifications) • Temperature controlled room¹ – \$50,000 - \$100,000 • Computer with controller and software² – \$5,000 - \$8,000 • Specimen insulation – \$200 • Data acquisition modules and chassis – \$1,500 - \$2,500; depending on number of thermal inputs • Heated oil bath for calibration of temperature sensors – \$800 (similar to Yamato BO400) 		<ul style="list-style-type: none"> • Specimen Mold³ – \$500 - \$1,500 		
Total Approximate Cost: \$60,000 - \$110,000				
≤ 30 Days	Concrete	≤ \$30,000	Uncomplicated	No Hazards
✓	✓	X	X	✓

¹The temperature controlled room is only specified to be “heavily insulated”. An example room comprises of two layers of masonry units with 5 - 7 in. of rockwool insulation between, and the floor is a 4 in. thick concrete slab upon 10 in. thick vermiculite concrete (as insulation) which is placed on another 4 in. reinforced concrete floor. The interior walls are 1 in. thick plaster that are sprayed with aluminum paint. The heating/cooling system is installed in the ceiling (thermally insulated from the interior) and delivered through perforated wall panels.

²Computer requirements vary depending on thermal controller and software. Additionally, any processing of the signal may require additional software that FDOT may or may not have licenses for such as LabView to generate graphical user interfaces for the computer.

³The specimen molds are not standard sizes and would need to be fabricated for each test. The material specified for the molds is not widely available (limited suppliers in North America) and would need to be either welded or soldered. Furthermore, fixtures need to be placed onto the lid to hold the temperature sensors which can be fabricated ahead of time. As the material specified is not corrosion resistant, it would be preferred to fabricate the specimens shortly before testing, however this tends to make cost rise due to short run fabrications.

Drawbacks of the Method:

The largest drawback of the USBR adiabatic test method is cost; this method requires a dedicated room with a custom heating and cooling system designed to match a thermocouple. Following the room costs, the method requires relatively costly one-time use molds, which are custom made. As the molds are almost complete cylinders (with two lids welded or soldered in place) they cannot be nested or stored efficiently, thus bulk purchasing would require a large amount of conditioned storage space. The storage space would need to be conditioned because the material specified (“black iron”) is not corrosion-resistant (such as more widely available material including aluminum, stainless steel, or an aluminum coated steel sheet product).

Furthermore, the method requires the presence of a technician at the time of casting have the necessary skills to solder the lid in place in a water-tight manner. In all likelihood, this would require several technicians in the laboratory to be trained to have this skill to ensure that at least one person is present and available for the task.

2.2.2. RILEM Method

RILEM TC 119-TCE describes a method of adiabatic testing and includes general design considerations for performing an adiabatic test with prescriptions on calorimeter design, materials, controls, and concrete size, shape, and characteristics [5]. The concrete specimen is to be cast into a cylinder of approximately 245 in.³ (4,000 cm³); with a minimum dimension of three times the maximum aggregate size, with a recommended maximum aggregate size of 1 ¼ in. (32 mm).

The sample must have a PT100 resistance thermometer or thermistor inside of a metal tube in the middle of the specimen; to ensure good thermal conductivity with the concrete, the tube is filled with oil. The container is then sealed to be watertight. Once sealed, the container is placed on a thermal heater and surrounded with insulating material as shown in Figure 1. A flexible polyurethane foam jacket is placed around the specimen as insulation, and the entire assemblage is placed into a thermal jacket, which is plumbed to circulate water to create an isothermal surface at the interface with the flexible polyurethane foam. Finally, the water jacket is insulated with more foam and placed inside of a metal container for the remainder of the test. A computer controller monitors the temperature of the center of the concrete specimen and applies voltage to the heater as well as adjusts the water circulation temperature to warm the specimen (if necessary). Since the water jacket temperature should never exceed the temperature of the specimen, the heated water temperature is set slightly below that of the specimen; ultimately resulting in a small thermal loss from the system. Due to the requirement that the sample must not lose more than 0.02 K/hr, the offset temperature of the water jacket must be adjusted so that the adiabatic conditions are met, and the temperature sensor must have a sensitivity of ± 0.01 K. Given these design considerations, Table 2 provides a summary of the approximate costs to run the RILEM adiabatic test method for one sample.

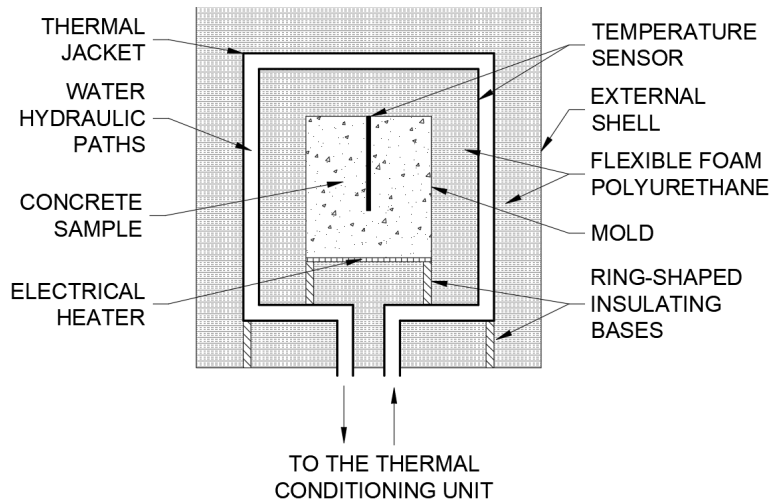

Figure 1. General diagram of adiabatic calorimeter design adapted from RILEM TC 119.

Table 2. Summary of required equipment and approximate costs using RILEM TC 119-TCE.

Non-Consumables – Approximate Cost		Consumables – Approximate Cost		
<ul style="list-style-type: none"> PT100 Sensor – \$110/ea (similar to OMEGA Item# PR-21SL-3-100-A-0600-M12-1) Foam Insulation, varies with specimen size – \$200 Thin heater² – \$75 (similar to OMEGA Item# SRFRA-10/10) Circulating water bath – \$5,500 - 6,000 (similar to PolyScience PS:AP15R-30-A11B or PS:AD15R-30-A11B) Water Jacket – \$3,000 (custom fabricated) Computer with controller and software³ – \$5,000 - \$8,000 Data acquisition modules and chassis – \$1,500 - \$2,500 		<ul style="list-style-type: none"> Thermowell – \$35/ea (similar to OMEGA Item# 1/2-260S-U71/2-304SS-F); dependent on temperature sensor size Specimen Mold¹ – \$15 ea + VAT + Int'l shipping 		
Total Approximate Cost:		\$16,500 - \$22,000		
≤ 30 Days	Concrete	≤ \$30,000	Uncomplicated	No Hazards
✓	✓	✓	X	✓

¹ One potential solution for a 4 L cylindrical container that is air tight is to purchase European paint tins. U.S. supply of 4 L cylindrical molds that are air-tight is limited and would likely require custom fabrication.

² Depending on the voltage of the heater (some are AC some are DC), a power supply and inverters or transformers may be required to drive the heater unit.

³ Computer requirements vary depending on thermal controller and software. Additionally, any processing of the signal may require additional software that FDOT may or may not have licenses for such as LabView to generate graphical user interfaces for the computer. This software would also have to control the thin electrical heater and is required for calibration.

This estimate does not include any associated labor, programming, or fabrication costs, or additional items such as modifying the concrete mold to hold the thermowell (for instance by drilling a hole in the lid and using bulkhead pipe fittings which the thermowell can be screwed into), or ancillary items like wiring or electrical connectors, uninterruptable power supplies, cabinets for the computer, tools for wiring, or other miscellaneous items that may be required for construction and execution.

Drawbacks of the method:

The accuracy of the method is largely dependent on sample size; Lee et al. researched commercially available adiabatic calorimeters in sizes of 6 L (1.6 gal), 30 L (7.95 gal), and 50 L (13.2 gal) and found that small specimen sizes (6 L) should not be used [7]. The results showed that the difference in ultimate adiabatic temperature rise between the 6 L and 30 L adiabatic calorimeters was approximately 10°C, 8°C, and 7°C for concrete mixes containing 500 kg/m³ (843 lb/yd³), 400 kg/m³ (674 lb/yd³), and 300 kg/m³ (506 lb/yd³) of 100% ordinary portland cement, respectively [7]. The largest difference between the 30 L and 50 L samples was approximately 1°C. Additionally, the shape of the specimen should have a diameter to length ratio as close to 1.0 as possible to prevent dimensional bias and increase self-insulation potential. The 6 L calorimeter tested had a L:D of 1.88, while the 30 L and 50 L calorimeters had L:D ratios of 1.0.

To account for these issues, the RILEM method would need to be modified to account for a much larger sample. One possibility would be to use a 20 gallon steel drum (19.5 in. dia. x 21.5 in. tall; L:D of 1.10). This sample size would require a larger PT100 probe, thermowell, water circulation system, heating element (available as 19.7-in. dia. kapton electric heaters), custom thermal jacket, and more insulation. The larger size would provide more accurate results but would result in higher initial costs as well as higher per-specimen costs.

2.2.3. CRD-C Method

The US Army Corps of Engineers CRD-C 38-73 *Method of Test for Temperature Rise in Concrete* prescribes a method for testing temperature rise using adiabatic calorimetry [13]. Similar to the USBR method, CRD-C 38-73 requires concrete to be placed into a soldered metal cylindrical mold. The temperature measuring devices are threaded through a wooden strap, which has holes drilled through it at 0 in., 2 in., and 12 in. from the center of the specimen in both directions. Once the concrete is placed and consolidated, the temperature probes are immediately immersed into the concrete, and a steel lid is soldered on top. For instrumentation, a thermocouple is attached to the top of the lid, two RTDs are placed outside of the specimen mold diametrically opposed, and two more RTDs are placed in-line with seven additional RTDs outside of the specimen insulating jacket as shown in Figure 2. The specimen is then placed into a heated cabinet, which is outfitted with two thermocouples and an RTD in the air. This cabinet is inside of a temperature controlled room which has two additional thermocouples in air.

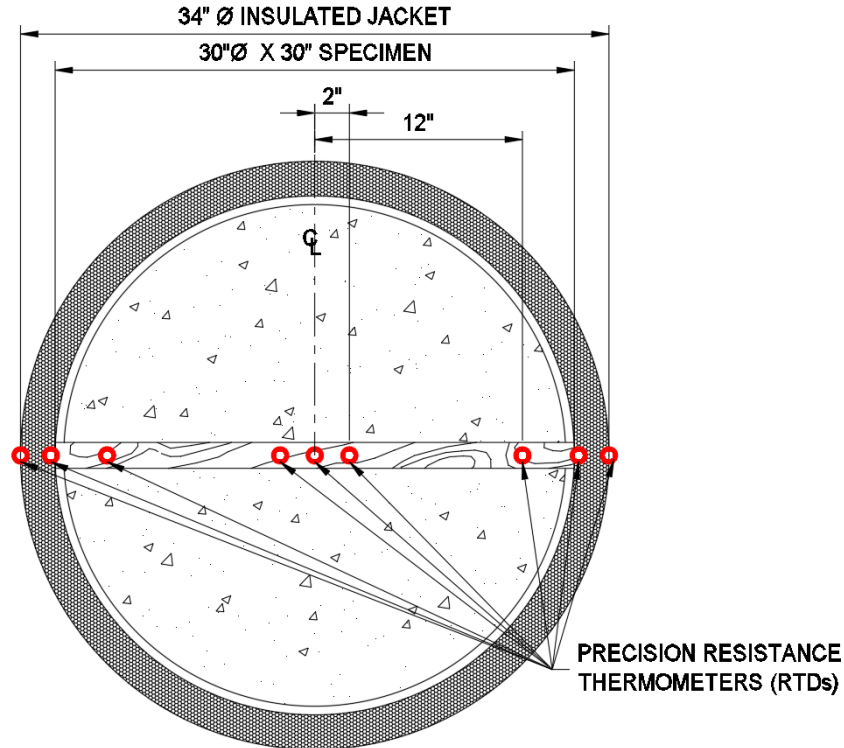

Figure 2. Plan view of insulated concrete specimen with location of RTDs per CRD-C 36-73.

The procedure for recording temperature of the specimen is similar to that of the USBR method; it is prescribed to be measured at 1- and 2-hours after mixing, then daily (during workdays) for 28 days. With the acceptance and availability of constant monitoring through computer data acquisition, real-time constant temperature recording can easily be achieved. The method also calls for daily temperature adjustments; the average of the four RTDs in the specimen that are located at 2 in. and 12 in. from the center are compared to the average of the two RTDs inside the metal jacket. Control of the cabinet heating system is adjusted to match the specimen temperature to the jacket temperature. This is done by adding resistors to the leads of the control RTDs to vary the signal to the temperature control, and a cumulative record of the difference is kept. The accumulated difference at the end of the test should not be more than $\pm 0.01^{\circ}\text{C}$. The use of a PID controller could be implemented to accomplish the task of temperature adjustment with higher resolution and frequency. While the CRD-C method is similar to the USBR method, there are some differences, which are outlined in Table 3.

Table 3. Differences between CRD-C 38-73 and USBR 4911.

	CDC-C 38	USBR 4911
Specimen Size	11.9 ft ³ (30 in. dia. x 29 in. tall cylinder)	4.5 ft ³ (21.5 in. dia. x 21.5 in. tall cylinder)
Embedded Temperature Sensors	5 precision resistance thermometers (consumable) (1 is used as a match for the chamber, 4 are averaged for specimen temperature recording).	2 PT100 RTDs; 1 is used as a match for the chamber, and 1 is used to record specimen temperature; reusable.
Specimen Thermal Regulation	Insulated, inside temperature controlled cabinet. Cabinet temperature must be within $\pm 0.002^{\circ}\text{C}$ of the specimen temperature. Adjustments to temperature controls are made daily, as necessary.	Insulated form, described as kapok (a type of plant wool), more recent experiments have used foam insulation.
Environment	Temperature controlled room capable of temperatures from 2 - 58 $^{\circ}\text{C}$; room temperature must be within 10 $^{\circ}\text{F}$ (5.5 $^{\circ}\text{C}$) of cabinet temperature at all times. Adjustments to temperature controls are made daily, as necessary.	Highly insulated room with heating and cooling system. Temperature must be controlled within $\pm 0.0055^{\circ}\text{C}$. Cooling system provides 18,000 Btu/h and heating system consists of heating coils capable of 204 $^{\circ}\text{C}$ (coil temperature, not air temperature). The air in the room is exchanged every 15 seconds.

The major equipment purchases required for the CRD-C 38 evaluation method include a highly controlled thermal cabinet, thermal room, data acquisition software, and several precision RTDs. Based upon this, the costs associated with implementing this testing method would exceed \$30,000 as described in Table 4.

Table 4. Summary of required equipment and approximate costs using CRD-C 38-73.

Non-Consumables – Approximate Cost		Consumables – Approximate Cost		
<ul style="list-style-type: none"> • Temperature controlled room – \$40,000 - \$70,000 • Precision RTDs– \$110/ea. (similar to OMEGA Item# PR-21SL-3-100-A-0600-M12-1) • Temperature controlled cabinet – \$20,000 • Computer with controller and software² – \$5,000 - \$8,000 • Specimen insulation – \$200 • Data acquisition modules and chassis – \$1,500 - \$2,500; depending on number of thermal inputs • Heated oil bath for calibration of temperature sensors – \$800 (similar to Yamato BO400) 	<ul style="list-style-type: none"> • Specimen Mold³ – \$1,500 - \$2,500 • Precision RTDs– \$110/ea. (similar to OMEGA Item# PR-21SL-3-100-A-0600-M12-1) 	Total Approximate Cost: \$70,000 - \$140,000		
≤ 30 Days	Concrete	≤ \$30,000	Uncomplicated	No Hazards
✓	✓	X	X	✓

¹The temperature controlled room is only specified to be “heavily insulated”. An example room is comprised of two layers of masonry units with 5-7 in. of rockwool insulation between, and the floor is a 4 in. thick concrete slab upon 10 in. thick vermiculite concrete (as insulation) which is placed on another 4 in. reinforced concrete floor. The interior walls are 1 in. thick plaster that are sprayed with aluminum paint. The heating/cooling system is installed in the ceiling (thermally insulated from the interior) and delivered through perforated wall panels.

²Computer requirements vary depending on thermal controller and software. Additionally, any processing of the signal may require additional software that FDOT may or may not have licenses for such as LabView to generate graphical user interfaces for the computer.

³The specimen molds are not standard sizes and would need to be fabricated for each test.

Drawbacks of the Method:

This method has all of the same drawbacks as the USBR method with the largest being the cost associated with the temperature control system including the room and separate cabinet. Additionally, five of the high precision temperature measurement devices are consumed with each test. This becomes a costly item and should be modified to make the sensors recoverable. The method also requires costly custom made single-use molds with wiring through water-tight fittings that must be fitted and tested for each specimen.

2.2.4. EN 12390 – Part 15

The European Standards for Testing Hardened Concrete (EN 12390) includes a section for the measurement of adiabatic temperature rise (Part 15) [14]. This method defines several characteristics that are used to describe calorimeters, such as “adiabatism error”, which is the

loss of temperature of a specimen in a calorimeter, generally given in °C/h. Additionally, the adiabatic equipment is defined in terms of adiabatism, where the loss from a chamber may not be more than 0.05°C/h in the temperature range of 20°C–70°C. It is recommended that the calorimeter specified for this method utilize a platinum (PT-100) RTD inside of a diathermal fluid-filled tube (similar to the USBR 4911 method) and that the chamber must be kept within ± 0.5°C of the specimen temperature. The specimen shall be either cubic or cylindrical with a volume of at least 3,000 cm³, which is to be placed into an insulated cell that has a waterproof lid to have as low a vapor permeability as possible. This calorimeter cell is equipped with at least one external temperature measuring device and is externally insulated.

The specification for this method was unavailable to the research team, therefore a full review of the method could not be completed, but inclusion of the method was deemed pertinent to the overall project should the FDOT choose to investigate this method further.

2.2.5. Existing Available Equipment

There are several commercially available systems available for the measurement of adiabatic temperature rise of concrete specimens; however, all of the equipment listed in this specification is “by quote” only, so cost determinations will be dependent on the supplier (direct from manufacturer versus distributor).

One such calorimeter is provided by Controls Group USA, Inc.; this calorimeter is equipped with PT100 RTDs for measurement of evolution of heat from the concrete sample and employs a closed loop heating system that is controlled through a PID controller. The specimen size is a 6 in. cube (4,195 cm³), and has a heat loss of 0.05°C/hr. Due to these systematic constraints, the specimen size is much too small to comply with USBR 4911 or CRD-C 38-73; while the specimen size is acceptable for RILEM TCE 119, the heat loss of the chamber (0.05°C/hr) is higher than allowable (0.02°C/hr). Therefore, this chamber does not meet the specifications of any of the standardized methods.

Marui & Co. manufacture a chamber (model: MIT-686-3-01) that raises the temperature to match the concrete specimen temperature from 10°C–80°C. This chamber measures the heat output from the specimen (15.75 in. dia. x 15.75 in. tall cylinder, 1.75 ft³ or 50 L maximum size) and matches the heat in the cabinet to the specimen; however, it lists the accuracy of the controller as ± 1°C, which does not meet any of the specifications. This controller could potentially be replaced with a more accurate version and calibrated, but the chamber would also need to be augmented with data acquisition to record the time-temperature history of the concrete specimen. Marui manufactures this chamber in a single-gang or double-gang version; however, the single-gang version is significantly outside of the acceptable price range.

Products Engineering, Inc produces a line of equipment known as “Sure Cure” aimed at pre-cast concrete manufacturers. However, they offer a variety of components that can be configured to produce a purported adiabatic condition. The system would require at least one Sure Cure hydration chamber (\$600, shown in Figure 3), along with a Curing Control System. The “Mini” Curing Control System (\$2,000 - \$3,500) allows for the control of up to three hydration chambers at once. The higher priced version of the system includes a computer and printer which

is required to run the system [15]. The company does not provide information as to the accuracy of the system; however, the temperature is monitored through Type T thermocouples, which have an accuracy of $\pm 0.5^{\circ}\text{C}$ if special limit thermocouples are used, and $\pm 1.0^{\circ}\text{C}$ if standard thermocouples are used. Additionally, most calorimeters of this type adjust temperature by an “offset” by raising or lowering the input heat by a set amount to account for errors in the system to produce an adiabatic condition; previous work showed that the finest adjustment in the Sure Cure system was $\pm 0.1^{\circ}\text{C}$, which can lead to temperature discrepancies of more than 10°C at 96 hours [6]. Therefore, it is unlikely that this system would provide sufficiently accurate results.



Figure 3. Sure Cure system with the computer, hydration chamber, and controller box by Products Engineering, Inc. [6].

2.3. SEMI-ADIABATIC TEST METHODS

2.3.1. RILEM Method

In addition to adiabatic testing, RILEM TC 119-TCE also describes a semi-adiabatic test method that uses a specimen of the same size and shape as the adiabatic calorimeter. The cylinder is of approximately $4,000\text{ cm}^3$ and the method prescribes an insulated vessel filled with foam rubber to protect the thermos vessel (Dewar type flask) from damage [5]. The calorimeter is to have a heat loss of not more than $100\text{ J/hr}/^{\circ}\text{C}$ and should be placed in an environment maintained at $20^{\circ}\text{C} \pm 1^{\circ}\text{C}$. Fresh concrete is placed into the thermos vessel along with a centrally located PT100 RTD when the concrete is within $\pm 2^{\circ}\text{C}$ of the ambient temperature as shown in Figure 4. The specimen temperature is then recorded until the end of the measuring period.

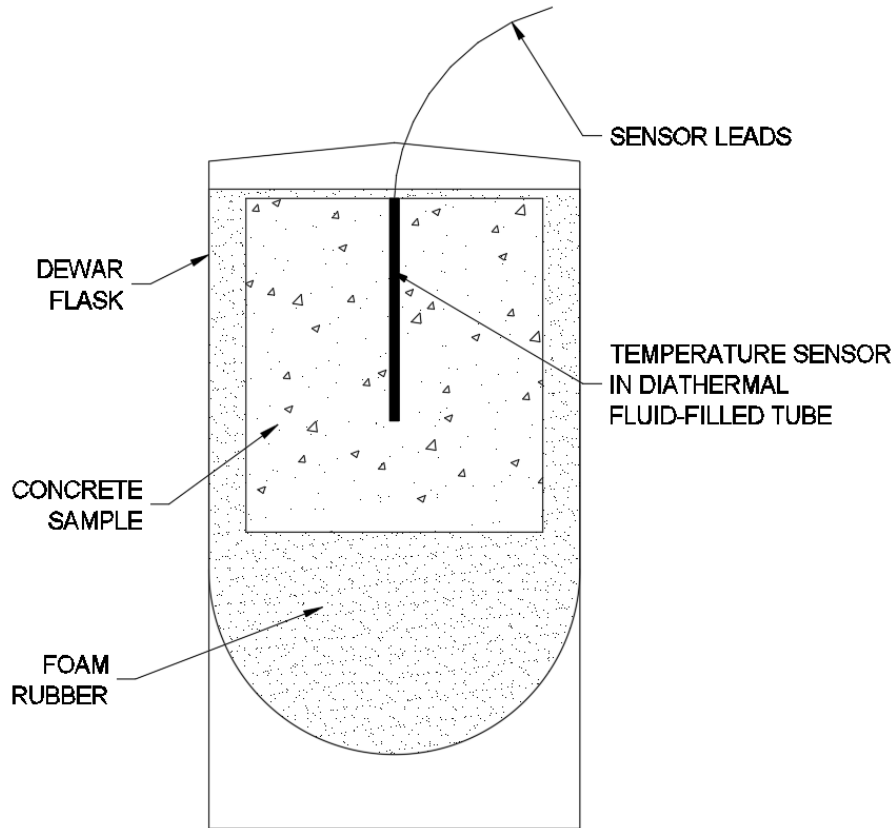

Figure 4. Example of semi-adiabatic measuring device from RILEM TC 119-TCE.

Once the measurement is complete, the specimen is removed from the semi-adiabatic vessel and stored to let hydration cease. The specimen is placed into an oven and heated to approximately 50°C; the specimen is then placed back into the semi-adiabatic chamber and allowed to dissipate the applied heat while the temperature is being recorded. Using these two temperature profiles along with an Arrhenius approximation and presumed maturity function, the temperature dependence of hydration can be estimated. An example of the calculation of this is presented in Appendix 4 of RILEM TC 119-TCE. Table 5 provides a summary of the approximate costs to run the RILEM semi-adiabatic test method for one sample.

Table 5. Summary of required equipment and approximate costs using RILEM TC 119-TCE.

Non-Consumables – Approximate Cost		Consumables – Approximate Cost		
<ul style="list-style-type: none"> • Dewar Flask– \$850 (similar to Fisher Scientific catalog number 50-197-7013) • PT100 Sensor –\$110 (similar to OMEGA Item# PR-21SL-3-100-A-0600-M12-1) 	<ul style="list-style-type: none"> • Diathermal fluid – \$1 per test (similar to Duratherm G) • Metal tubing for temperature probe – \$3 ea. (1ft. length of ¼ in. copper tubing and 1 cap; requires soldering/sweating to be water tight) or Thermowell – \$35/ea. (similar to OMEGA Item# 1/2-260S-U71/2-304SS-F); dependent on temperature sensor size 			
<ul style="list-style-type: none"> • Foam rubber insulation – \$120 (1 gallon of pourable rubber similar to SmoothOn VytaFlex-60) • Laboratory Oven – \$1,600 (similar to Humboldt model H-30140) • Computer and software¹ – \$600 - \$1,500 • Thermocouple logger – \$500 - \$1,000; (similar to OMEGA OM-CP-QUADTCTEMP-A2) 				
Total Approximate Cost:		\$3,850 - \$5,550		
≤ 30 Days	Concrete	≤ \$30,000	Uncomplicated	No Hazards
✓	✓	✓	✓	✓

¹ Computer requirements vary depending on thermal controller and software. Many thermocouple loggers come with software that can export data into Microsoft Excel or similar formatting.

Drawbacks of the Method:

In order to carry out the method with as little destruction to the rubber molding as possible, the specimens should be cast in thin plastic tube sleeves. This would allow easier removal of the specimen as well as calibration. The calibration of the calorimeter involves placing a “specimen” of distilled water at varying temperatures into the calorimeter to determine the coefficient of heat loss of the calorimeter. This calibration necessitates the need for a distilled water source and water heater; these considerations were not accounted for in the costs for the method as distilled water can either be produced with equipment or purchased from a store, and the water could be heated with the laboratory oven as the heated temperatures are not specific.

The calorimeter would likely need to have a custom formed rubber insulation made to accommodate the specimen size required. Additionally, the diathermal oil wells will need to be soldered or sweated to be waterproof. Since the environmental conditions play a significant role on the resulting data, having a dedicated conditioned space where the temperature is closely monitored and air currents are kept to a minimum will improve accuracy.

2.3.2. LCPC QAB

In 1986, a method was developed by the Laboratoire Central des Ponts et Chaussées (LCPC) in Lyon, France to investigate the use of a semi-adiabatic (called “quasi-adiabatic du béton” or QAB meaning “quasi-adiabatic for concrete”) cement calorimeter applied for use with concrete [16]. This method relies on large amounts of insulating foam rather than a vacuum flask for the insulative qualities. The method uses a 16 cm x 32 cm (approximately 6,400 cm³, 6.3 in. x 12.6 in., 0.23 ft³) cylindrical specimen inside a cardboard tube (specimen mold) that is placed into a steel caisson. The whole assembly is then installed into a foam-insulated chamber having approximately 14 cm (5.5 in.) of foam surrounding the specimen as shown in Figure 5. This general type of calorimeter is more widely available as a product and in a variety of configurations that vary in dimension.

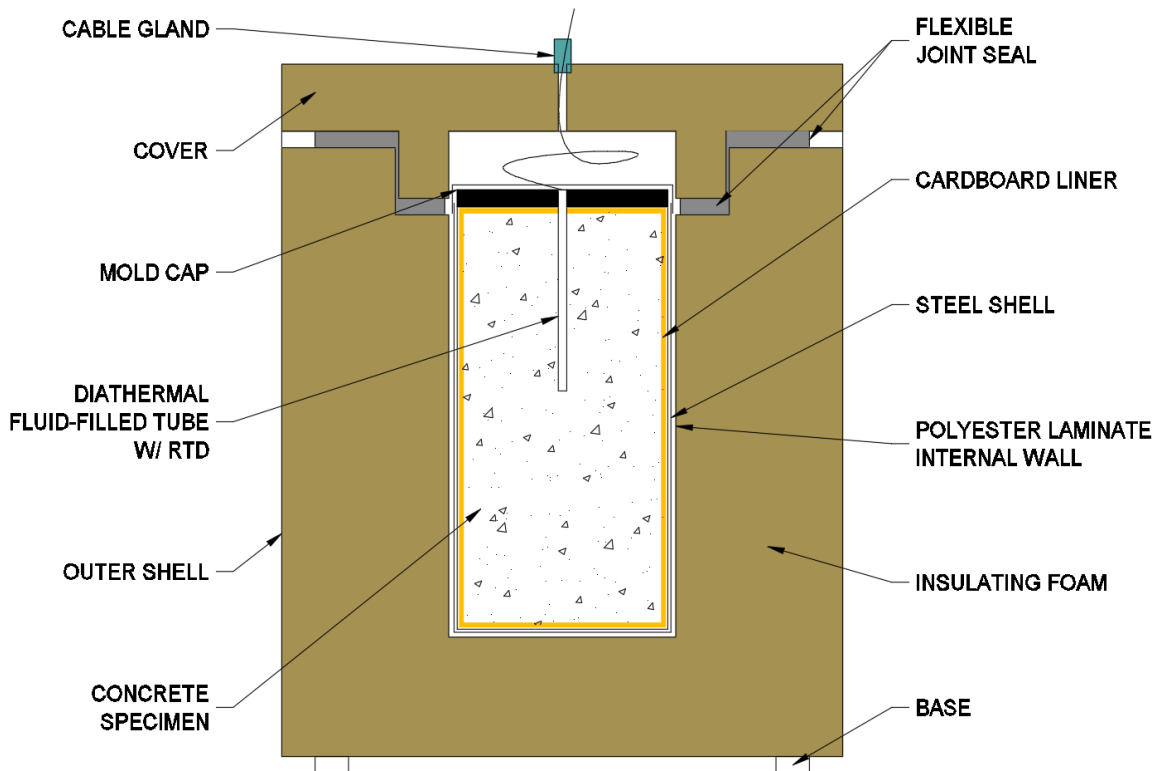

Figure 5. Example of semi-adiabatic measuring device used for LCPC QAB.

The LCPC method utilizes the transient heat loss of the specimen in the calorimeter as well as a companion, mature (3 months or older) concrete reference sample in an identical calorimeter. These calorimeters are placed in an environment kept at 20°C (68°F) for the duration of testing. The temperature changes of both specimens are recorded, and similar to measuring hydration during isothermal conduction calorimetry, the changes in temperature of the reference sample are “subtracted” from the reacting specimen and treated as environmental effects. The temperatures inside both calorimeters as well as outside of the calorimeters is measured every 10-15 minutes, and the outside temperature is used to control the environmental temperature system. Boulay et al. [17] describes in detail the testing procedures, calorimeter construction, influential factors, as well as the procedures for analyzing and correcting data obtained in this method. Most calorimeters of this type are designed to be mobile for deployment in the field (when strict

environmental control is not necessary) and therefore utilize large carrying cases that are usually filled with cast foam. Table 6 provides a summary of the approximate costs to run the LCPC QAB semi-adiabatic test method for one sample.

Table 6. Summary of required equipment and approximate costs using LCPC QAB.

Non-Consumables – Approximate Cost		Consumables – Approximate Cost		
<ul style="list-style-type: none"> • Calorimeter body – \$200 - \$1,500 (based on size and material) • PT100 Sensor – \$110 (similar to OMEGA Item# PR-21SL-3-100-A-0600-M12-1) • Foam polyurethane insulation – \$70 (similar to US Composites b2LB Density expanding polyurethane foam – 8ft³ kit) • Steel Liner – \$400 (custom fabrication) • Polyester Laminate – \$25 • Rubber Seal – \$100 (custom fabrication) • Computer and software¹ – \$600 - \$1,500 • Thermocouple logger – \$500 - \$1,000; (similar to OMEGA OM-CP-QUADTCTEMP-A2) 	<ul style="list-style-type: none"> • Diathermal fluid – \$1 per test (similar to Duratherm G) • Metal tubing for temperature probe – \$3 ea. (1ft. length of ¼ in. copper tubing and 1 cap; requires soldering/sweating to be water tight) or Thermowell – \$35/ea. (similar to OMEGA Item# 1/2-260S-U71/2-304SS-F); dependent on temperature sensor size • Cardboard Liner – \$6 (a case of 6 in. x 24 in. tubes is approximately \$60; a tube that is 6 in. x 14 in. would produce a specimen of approximately 0.23 ft³). 			
Total Approximate Cost:		\$4,600 - \$7,250		
≤ 30 Days	Concrete	≤ \$30,000	Uncomplicated	No Hazards
✓	✓	✓	✓	✓

¹ Computer requirements vary depending on thermal controller and software. Many thermocouple loggers come with software that can export data into Microsoft Excel or similar formatting.

Note: If this method was carried out with a companion specimen, all of the costs (with the exception of the computer, software, and data acquisition hardware) would be doubled. Additionally, the costs do not incorporate room with a temperature of 68°F; as there is no specification associated with this method, a modification to the standard 73°F ± 3°F would be acceptable.

The calibration for the LCPC QAB method involves taking mature concrete specimens in each calorimeter to lower than the conditioned room temperature, approximately 60°F, and then raising the temperature of the room to approximately 80°F. The differences in measurements of each calorimeter are measured over the course of several days. The mature reference cylinders are swapped and the calibration is repeated to determine whether the errors observed are mostly caused by differences in calorimeter construction or differences in the references.

Drawbacks of the Method:

This specific configuration of calorimeter cannot be purchased off-the-shelf and would likely need to be fabricated; similar calorimeters available for purchase that purport to provide the same information will be provided at the end of this section. To perform this method, the acquisition of two calorimeters is required. The diathermal oil wells will need to be soldered or sweated to be waterproof.

The calibration of the method requires that the room be able to have thermal control in the range of approximately 60°F–80°F. It is recommended that the calorimeters are placed on an elevated surface high enough to encourage air circulation over the bottom of the calorimeter (such as a table) but low enough to allow for ease of specimen insertion and removal.

This method is susceptible to the same environmental concerns as the RILEM method wherein temperature should be kept constant and air currents should be minimized; however, the use of a companion specimen in an identical calorimeter removes some of the error associated with environmental factors.

2.3.3. NT Build 388

The NordTest 388 describes general details for the apparatuses, procedures, and data analysis for three different methods of heat measurement. The semi-adiabatic method has a concrete specimen placed in an insulated box with thermal flux sensors on the insulation walls as well as an embedded temperature sensor (called a “HayBox calorimeter”). The temperature of the concrete and the accumulated heat passing through the heat flow sensors are combined to give total heat; this is measured until the specimen has reached 300 hours of maturity [18].

A simplified version of this method involves placing the concrete in direct contact with the walls of a “well-insulated box”; there is a single temperature sensor embedded in the center of the specimen, and the temperature is recorded (along with the ambient temperature) at least once per hour for a period of at least three days. The method uses a minimum specimen size of 1-meter cube, with insulation that loses heat no faster than 5 kJ/(m²-hr-°C); this is equivalent to an R-value of 0.72 or higher, which is comparable to ¾-in. thick plywood. The method does not list any other specifications for the calorimeter construction, temperature measuring devices, concrete specimen sizes, molds, environment, or chambers.

Determining a cost to perform this method would vary depending on the level of accuracy desired. A single block of 1 m³ made of ¾-in. plywood with 2 in. x 4 in. frame supports along with two thermocouples and a data logger could be constructed for less than \$2,000. This would be reusable for a number of specimens, but eventually have to be replaced. However, without proper insulation the data would not be reliable. Costs begin to rise when accounting for additional insulation, temperature sensors, temperature control measures, disposal hardware (such as lifting and rigging equipment), and other design considerations for specimens as large as 1 m³. The relative expense, provided in Table 7, and ease of performance of this test appear to be the only positive aspects of this method.

Table 7. Summary of required equipment and approximate costs using NT Build 388.

Non-Consumables – Approximate Cost		Consumables – Approximate Cost		
<ul style="list-style-type: none"> • Thermocouple extension wire for air temperature – \$65 (similar to Omega EXTT-TI-20-SLE-15M) for 50 feet of wire 		<ul style="list-style-type: none"> • Thermocouple extension wire – \$20 (similar to Omega EXTT-TI-20-SLE-15M) 		
<ul style="list-style-type: none"> • Thermocouple logger – \$500 - \$1,000; (similar to OMEGA OM-CP-QUADTCTEMP-A2) • Formwork – \$500 				
Total Approximate Cost: \$1,100 - \$1,600				
≤ 30 Days	Concrete	≤ \$30,000	Uncomplicated	No Hazards
✓	✓	✓	✓	✓

Drawbacks of the Method:

The NT Build 388 method lacks prescription of thermal control and insulative measures that would result in adequate results, thus the method would need to be modified heavily. The insulative requirements are exceptionally low, meaning the concrete would quickly lose thermal energy to the surrounding environment resulting in poor results. The environment should be thermally controlled or the rate of thermal loss will vary with external temperature. The length of time (three days) of measurement is much too short of a time period for accurate measurement of a specimen of this size. The large size of the specimen would also create logistical difficulties for casting and specimen removal.

A specimen insulated with only plywood specimen (R-0.72) and similarly sized to the one specified for this method was measured for heat rise in comparison to an identical specimen with R-36 insulation on all sides; the heat evolution difference is shown in Figure 6.

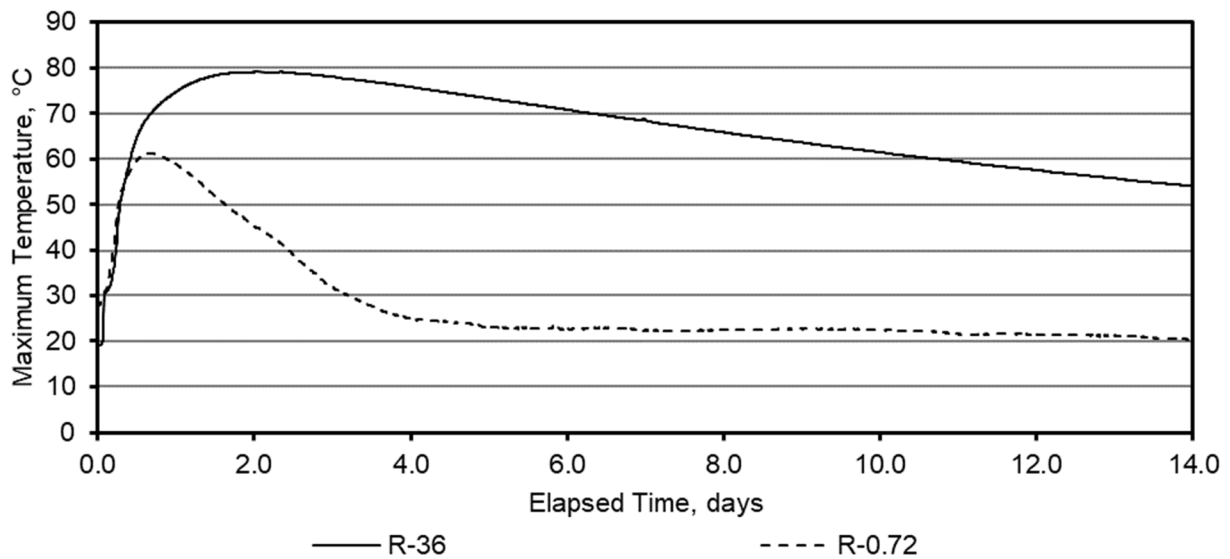

Figure 6. Differences in maximum heat generation between an effectively uninsulated and well-insulated concrete specimen [19].

2.3.4. EN 12390 – Part 14

The European Standards for Testing Hardened Concrete (EN 12390) Part 14 [20] describes a method to measure heat ride of hydrating concrete in comparison to a reference cylinder of similar heat capacity and heat loss coefficients in a separate calorimeter.

The specification for this method was unavailable to the research team, therefore a full review of the method could not be completed, but inclusion of the method was deemed pertinent to the overall project should the FDOT choose to investigate this method further.

2.3.5. ASTM C1753

ASTM C1753 - *Standard Practice for Evaluating Early Hydration of Hydraulic Cementitious Mixtures Using Thermal Measurements* is a specification that outlines the procedures for evaluating the early age heat release of hydrating cement paste, mortar, or concrete under isothermal, “near-adiabatic”, and semi-adiabatic conditions. This method states that “*This practice cannot be described as calorimetry because no attempt is made to measure or compute the heat evolved from test specimens due to hydration...*” [21]. ASTM C1753 is generally used to indicate variability in sulfate balancing and time of setting, and is specifically not meant for use as a “calorimetry” method to determine semi-adiabatic or adiabatic calorimetric temperature rise. Therefore, the results from this method are qualitative rather than quantitative and do not provide heat of hydration. Specifically, this method clarifies that “*thermal profiles from this practice do not provide quantitative measurement of heat of hydration, are affected by various details of the test conditions and mixtures (see 3.2.10 and the Appendix), and are subject to greater variability.*”

Additionally, Section 5.7 states that *“This practice is not intended to provide results that can be compared across laboratories using different equipment nor to provide quantitative measurements or corrected approximations of actual hydration heat. It should not be cited in project specifications or otherwise used for the purpose of acceptance or rejection of concrete. It is intended to serve as a simple and expedient tool for comparison of the relative early-age hydration performance of different specific combinations of materials that are prepared and stored under the same conditions.”* This method simply provides a means to compare within laboratory results of concrete heat of hydration using similar “thermal measuring devices”. As such, this method is not recommended.

2.3.6. Existing Available Equipment

The existing off-the-shelf systems for semi-adiabatic temperature rise measurement are similar to the LCPC WAB/ASTM C1753 variety rather than the vacuum flask (RILEM) type, which has fallen out of favor in the last 30 years due to the variety of rugged materials that can be used to make calorimeters that do not require glass vacuum flask containers.

ConTech Analysis Aps is a company in Denmark that offers a single channel semi-adiabatic calorimeter called a Heat-Box, that is most similar to the LCPC QAB variety. This calorimeter is a 24 in. cube and accepts standard 6 in. x 12 in. concrete cylinder molds. The calorimeter comes with software that automatically corrects for the ambient temperature as well as the thermal conductivity of the calorimeter to output a curve. The output can be expressed using the Arrhenius or Nurse-Saul maturity and can be exported as raw data. The calorimeter including software costs \$4,400. The company also sells the software separately (for \$2,400) and includes instructions on how to build a calorimeter that will house equipment of your own choosing in order to not have to purchase larger equipment and have it shipped from Denmark. The calorimeter and data logger can be purchased without software (\$2,400), so in the case of running a specimen and a reference, the total cost would be \$6,800 [22].

Calmetrix, Inc. has developed several iterations of semi-adiabatic calorimeters from single-channel (P-Cal 1000), 4-channel (F-Cal 4000), and 8-channel (F-Cal 8000, and 8100). Currently, only the 8-channel variant (F-Cal 8100) is available; this calorimeter utilizes 3 in. x 6 in. concrete cylinders in an insulated carrying case [23]. Similar to the previous generation 4-channel calorimeters, the 8-channel calorimeter is insulated on the sides of the specimens and not the top (whether the bottom is insulated is unclear). When using a reference sample, the calorimeter would have 7 channels available for measurement. This chamber is designed for field applications of up to 36 hours (likely due to battery life), and the internal storage can store approximately 7 days’ worth of data before becoming full. The software required to analyze the data (CalCommander and its variants) is available for free download on the Calmetrix website. While Calmetrix does not list a price on their website, it is likely that the cost would be less than the \$30,000 cost limit for FDOT.

Quadrel, Inc. produces a type of calorimeter called an IQ Drum, which has the capability of measuring either a 4 in. x 8 in. concrete cylinder or 6 in. x 12 in. cylinder. Quadrel does not publish data on the accuracy of their measurements or data logging system. The information available states that the calorimeters are internet-connected to initiate testing and data retrieval,

and use software to convert the semi-adiabatic heat rise profile into an adiabatic temperature rise curve. Pricing information is not made available on the website, and the calorimeter comes with a software package that requires a yearly subscription. The software is geared towards a concrete producer that wants to simulate placements, create a mix design database, and predict thermal cracking; whether this software package is strictly necessary to simply run the calorimeter is not made clear. It is presumed that the cost would be higher than the \$30,000 threshold when including the software license.

2.4. ISOTHERMAL TEST METHODS

2.4.1. ASTM C1679

ASTM C1679 - *Standard Practice for Measuring Hydration Kinetics of Hydraulic Cementitious Mixtures Using Isothermal Calorimetry* is widely used in the cement and concrete industry to measure the heat of hydration of cementitious pastes and mortars [8]. The scope of the method states “*This practice describes the apparatus and procedure for measuring relative differences in hydration kinetics of hydraulic cementitious mixtures, either in paste or mortar (see [Note 1](#)), including those containing admixtures, various supplementary cementitious materials (SCM), and other fine materials by measuring the thermal power using an isothermal calorimeter.*” The Note 1 referenced discusses the benefits of mortars compared to pastes as it relates to concrete setting time prediction. Therefore the scope of this method does not include concrete, despite a couple references to concrete in the appendices. The marketing literature of companies selling isothermal calorimeters state compliance with ASTM C1679 and able to evaluate concrete, but not in the same sentence. This verbiage is meant to state that the calorimeters are compliant with ASTM C1679 (for pastes and mortars), and separately, there are cells available for testing concrete; this is because the testing cells for concrete can be replaced with smaller cells to test mortar or paste samples. Examples from the two major isothermal calorimeter manufacturers in North America are provided below:

Features and Benefits of the TAM Air isothermal calorimeter from [24]

- *Choice of two volumes, 20 and 125 mL, to allow measurements of either cement or concrete*
- *Conforms to the standards of ASTM C1702 and ASTM C1679*

Excerpt from Calmetrix Product lineup and specifications brochure [25]

	i-Cal Flex
Type of calorimeter	Isothermal
Sample Type	
Cement paste	✓
Mortar	✓
Concrete	✓
Standards and norms	
ASTM C1679 (Isothermal calorimetry)	✓
ASTM C1702 (Heat of hydration testing)	✓
ASTM C563 (Sulfate optimization)	✓
ASTM C1897 (SCM reactivity)	✓
EN-196-11 (Heat of hydration testing)	✓

These statements are misleading and could allow someone to believe that these calorimeters can evaluate concrete with respect to any of these specifications, which is not accurate.

The apparatus described in ASTM C1679 as well as the mixture composition are specifically for pastes and mortars, and do not describe methods for preparing concrete specimens. As such, this method should be viewed as a method that references concrete, rather than a method designed for evaluating concrete.

Drawbacks of any isothermal method for concrete is that the specimen size makes isothermal conditions a near impossibility through the bulk of the material. While a temperature gradient is required to drive heat energy through the heat flow sensors, a bulk concrete sample would not be able to remain at a consistent temperature through the bulk of the specimen with any of the apparatuses proposed. At the present time there is not a standard method to accurately measure the isothermal heat generation of a concrete. Furthermore, a calorimeter has not been commercially developed that can adequately evacuate heat from a suitably sized concrete specimen; despite a number of calorimeters purporting to be able to do so. For completeness, a list of some of the commercially available isothermal calorimeters that can house concrete are presented below. However, it should be noted that isothermal calorimetry is not a recommended method for concrete evaluation.

2.4.2. Existing Available Equipment

TA Instruments has made available a 3-channel calorimeter, which allows for the measurement of three 125 mL specimens simultaneously. The specimens are mixed externally, placed into disposable glass ampoules (\$325 ea.), and loaded into the calorimeter for the measurement period. Physical separation of the channels is important for the reduction of cross-talk between specimens. Previous purchases of the calorimeter and thermostat chamber have been in excess of the \$30,000 cost limitation. The major drawback to this piece of equipment, beyond cost (both up front and per specimen) is that the specimen size (125 mL) is approximately 7.5 in³ (smaller than a mortar cube) which is not representative of typical concrete with aggregate larger than #8 stone.

Calmetrix offers a number of isothermal calorimeters in a variety of configurations from an 8-channel (20 mL), 2-channel (125 mL), 4-channel (125 mL), 8-channel (125 mL, this chamber is either missing reference samples, or the references are pre-loaded under the specimens), and a new calorimeter that can be configured to have one of three configurations: 8-channel – 20 mL, 5-channel – four 20 mL and one 425 mL, and a 2-channel – 425 mL configuration. From the marketing literature, the ampoules used in the 425 mL calorimeter (called the I-Cal Flex) are plastic, which should reduce operating costs significantly. Additionally, the much larger size is equivalent to approximately 26 in³. However, these ampoules appear to have domed bottoms, which would make poor contact with the only heat sensor in the calorimeter. This would result in a large amount of heat lost to the surrounding metal housing that is not measured by the machine. On the positive side, the size of the container would likely be close to the size required for a representative sample for #57 stone mixes. With a nominal maximum aggregate size of 1 inch, most 425 mL cylindrical containers available have a diameter over 80 mm (3.15 in). This would result in a cylinder approximately 3.15 in. x 3.3 in. tall. The ampoules should be replaced with flat bottom containers which are taller, this would allow for a larger sample.

Toni Technik GMBH, a German company, manufactures an isothermal calorimeter for a full sized 4 in. x 8 in. concrete cylinder, deemed the ToniCAL Concrete Model 7336 [26]. The calorimeter supports RS 232 communication as well as the ability to heat the specimen via a heating element radially around the specimen. The marketing literature is translated from German, and therefore, is not completely clear, but it appears that the calorimeter may have thermosensing elements radially around the specimens, which would be an improvement over the other designs. There is no price indicated for this calorimeter, but as it is European it would likely have VAT assessed, and would also likely be more than \$30,000. The largest detractor to this piece of equipment is that the size and shape mean the concrete would likely not be in an isothermal condition throughout the mass. Concrete is self-insulating and the thermal energy at the center of the mass would take time to diffuse through the specimen and into any thermal sensors, which would be recorded as hydration delays.

2.5. SUMMARY

A summary of the available testing methods for measuring heat rise of concrete and the applicability to FDOT requirements for implementation is presented in Table 8. The adiabatic test methods are universally complicated and require a high degree of technical knowledge to perform and two of the three methods are considerably higher than the \$30,000 budget that FDOT would like to allot to evaluating this metric.

While the semi-adiabatic test methods meet each of FDOT criteria, it is not recommended that any of these methods is pursued without modification. The most likely candidate for ease of development would be the LCPC QAB test method; all of the methods suffer from having too small a specimen size to produce accurate results, while the LCPC uses the largest specimen size. Experimentation would need to be performed to validate the testing procedures and modify as necessary to accommodate larger specimens to attain accurate heat profiles.

Isothermal testing of concrete is not currently determined to be feasible for all concrete mixtures and is therefore not recommended. Sample sizes required for evaluating representative

specimens of concrete would produce heat much faster than commercial designed calorimeters are capable of removing in a timely manner. Furthermore, there is not a standardized test method that describes a method to measure the heat of hydration of a concrete specimen under isothermal conditions.

Table 8. Summary of criteria for heat evolution test methods.

		≤ 30 Days	Concrete	≤ \$30,000	Uncomplicated	No Hazards
Adiabatic	USBR Method	✓	✓	X	X	✓
	RILEM Method	✓	✓	✓	X	✓
	CRD-C 38-73	✓	✓	X	X	✓
Semi-adiabatic	RILEM Method	✓	✓	✓	✓	✓
	LCPC QAB	✓	✓	✓	✓	✓
	NT Build 388	✓	✓	✓	✓	✓
Isothermal	No standard method exists for determining heat of hydration of concrete					

3. CRACKING TENDENCY TESTING

3.1. BACKGROUND

Concrete experiences cracking when the tensile strength is exceeded by the combinatory tensile stresses that are applied and induced. When a concrete placement begins, the hydration process starts a series of chemical reactions that result in the hardening of multiple cement phases that will ultimately determine setting, compressive strength, tensile strength, modulus, and coefficient of thermal expansion, amongst a number of other factors. The material combinations of the cementitious components along with the aggregates, mineral and chemical admixtures, and water content will have impacts on these parameters.

During the hydration process, there are four main forms of shrinkage that will result in concrete changing volume: plastic shrinkage, chemical shrinkage, autogenous shrinkage, and drying shrinkage. Plastic shrinkage defined as “*shrinkage that takes place before cement paste, mortar, grout, or concrete sets*” [4] and is the result of a volume of water evaporating from the volume of concrete. This reduction in mass leads to a contraction of the microstructure of the cement paste as well as the incorporated aggregates [27]. This shrinkage can result in cracking at the surface where water evaporates faster than water from the inner volume of concrete can migrate during the bleeding process, resulting in tensile forces at the surface overcoming the tensile strength of the fresh concrete when shrinkage occurs before hardening [27].

During the process of hydration, free liquid water is bound by chemical processes into solid hydrates (such as calcium silicate hydrate, or C-S-H); this conversion to bound water can result in a total reduction of volume known as chemical shrinkage. While chemical conversion to bound water begins at the outset of hydration (essentially immediately upon introduction of mixing water) the observed shrinkage occurs primarily after setting has taken place, and continues until hydration ceases when sufficient external sources of water are not present.

Autogenous shrinkage is the macroscopic volume change (visible dimensional change) of a unit of concrete. The American Concrete Institute’s *Concrete Terminology* terms “autogenous shrinkage” as “autogenous volume change” and defines it as “*change in volume due to the chemical process of hydration of cement, exclusive of effects of applied load and change in either thermal condition or moisture content*” [4]. This shrinkage is largely observed prior to setting because once final setting has initiated, the concrete volume has sufficient structural capacity to resist the internal tensile forces caused by the chemical shrinkage creating pore tension. Therefore, prior to setting, when the concrete is plastic, the chemical shrinkage and autogenous shrinkage are essentially the same due to the lack of structural rigidity to resist contraction. Following setting, the concrete exhibits structural rigidity to shrinking in the bulk volume (autogenous), but the conversion of free water to bound water (chemical shrinkage) continues, as shown in Figure 7. Cementitious pastes with sufficient external water sources will not undergo autogenous shrinkage, [27]; however, in concrete, placements are sufficiently thick such that external water sources cannot permeate readily enough to prevent autogenous shrinkage. Autogenous shrinkage is exacerbated by concretes with higher paste contents as would be expected; however, the shrinkage is also increased by lowering water to cementitious materials ratio [28].

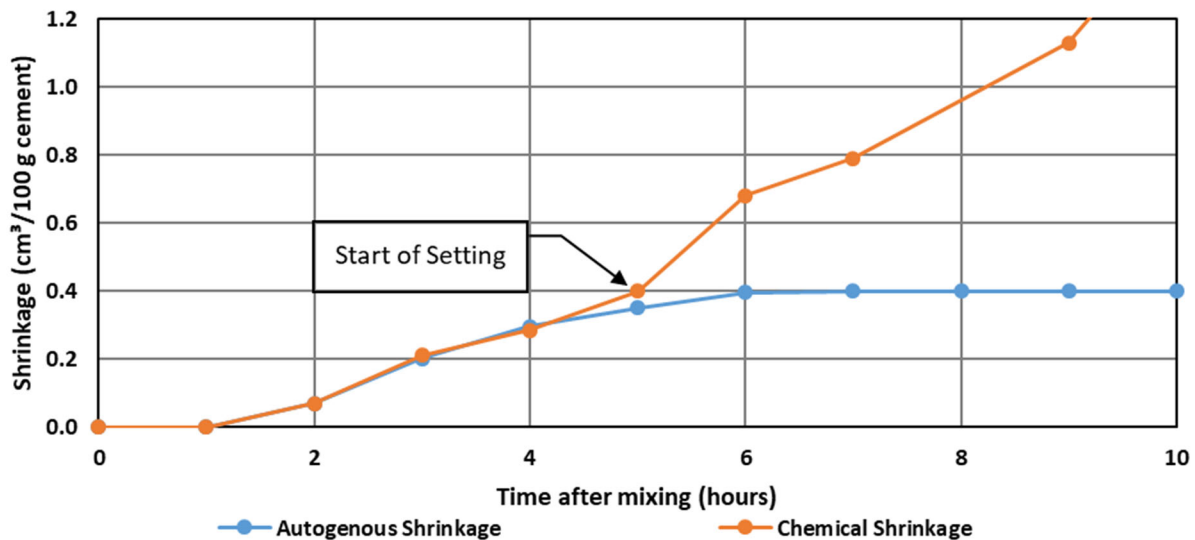

Figure 7. Relationship between autogenous and chemical shrinkage, adapted from [29].

Following hardening, when external sources of water are depleted, unbound water (from the pore fluid) can be evaporated from the exposed surfaces of the concrete; this is known as drying shrinkage. This form of shrinkage is most affected by external factors such as humidity, wind

exposure, amount of reinforcement (restraint), and concrete mixture proportions, amongst other factors.

Testing of concrete resistant to shrinkage cracking are generally grouped into two forms of evaluation methods: restrained and unrestrained testing. Restraint is defined in the American Concrete Institute's *Concrete Terminology* publication as "restriction of free movement of fresh or hardened concrete following completion of placing in formwork or molds or within an otherwise confined space" [4]. All structural concrete is restrained in one fashion or another; this could be in the form of reinforcing steel, slab on grade, placement adjacent to other members, or other construction factors. As such, the tendency for cracking of a given application is not only defined by the cumulative shrinkage associated with the mixture components, but also is affected by the design considerations for each placement. By comparison, unrestrained concrete specimens are allowed to expand or contract due to hydration and environmental effects without the confounding effects of additional reinforcement such as reinforcing bar, fibers, or cast restraining geometries. These tests generally measure the bulk volumetric or linear change of the specimen without measurement of the stresses induced during the volumetric change. These methods are typically less technically intricate and therefore cost less, but will also generate less quantitative (and sometimes qualitative) data.

3.2. RESTRAINED SHRINKAGE

The various direct testing methods for determining cracking tendency of concrete can be grouped into one of several groups; ring tests or slab/panel tests. The general theory behind initiating failure for the ring tests is similar, but the testing apparatuses and procedures may vary. As a primer to these methods, a general description of the underlying theory is provided below.

For concrete ring tests, concrete is placed around a steel ring which provides restraint. As the concrete hardened and begins to shrink, the steel ring prevents contraction, which results in tensile forces growing annularly in the concrete (and compressive forces radially in the steel ring) as shown in Figure 8. Once these tensile forces are greater than the tensile strength of the concrete, a crack develops to release strain energy. This release of energy results in a reduced compressive force on the ring; strain gauges applied to the inner wall of the steel ring record the strain on the steel ring over time; when the strain is suddenly reduced, this is indicative of a concrete crack.

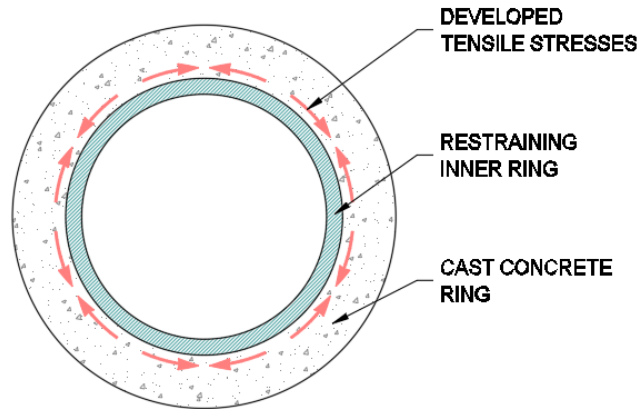

Figure 8. General diagram of a concrete ring cracking test.

3.2.1. ASTM C1581

The ASTM C1581 specification prescribes a method to determine the age at cracking and induced tensile stress characteristics of mortar or concrete specimens under restrained shrinkage [30]. This specification calls for the use of a testing apparatus consisting of a non-absorptive base, on which is mounted eight bolts with eccentrically mounted washers. Concentric rings are placed in such a way that the eccentric washers can be rotated to secure the rings to the base, and concrete is cast between the rings. The inner ring is required to be steel and is approximately 13 in. outside diameter with a thickness of 0.5 in.; on the inner face of the ring (not where the concrete is cast) are two diametrically opposed surface-mounted strain gauges mounted in a quarter-bridge configuration as shown in Figure 9. A data acquisition system capable of monitoring the system to within $\pm 0.5 \mu\epsilon$ and at a sampling rate of at least once per 30 minutes (0.033 Hz). The inner ring material may be made of non-absorptive and non-reactive material such as steel, Schedule 80-18 PVC, or similar.

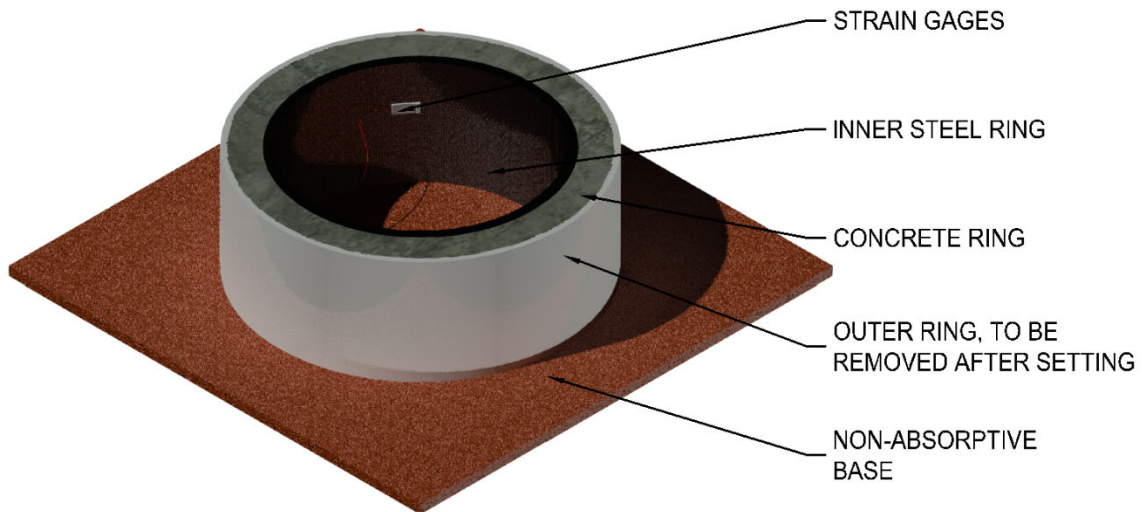

Figure 9. Ring test setup for ASTM C1581.

After mixing, three specimens must be created for each evaluation. The concrete is placed into the molds in two equal lifts in each mold and consolidated either with a vibrating table or by rodding 75 times per layer. The specimens are then transferred to a curing environment that is kept at $23^{\circ}\text{C} \pm 2^{\circ}\text{C}$ ($73.5^{\circ}\text{F} \pm 3.5^{\circ}\text{F}$) and $50\% \pm 4\%$ RH within 10 minutes of casting. Once in the curing environment, the bolts and eccentric washers are loosened to not be in contact with the outer ring, and the strain gauge data should begin to be acquired. For the first 24 hours, wet burlap shall be placed over the specimens, followed by polyethylene film to moist-cure the specimens. The outer ring is removed at 24 hours after mixing, but the seal is left to remain and the specimen is left on the base; this allows evaporation to occur from only the outer face of the concrete.

After the 24 hour curing regime, the drying preparation must begin and be completed in 15 minutes. This process involves removing the polyethylene film and wet burlap, remove any loose material from the top and a seal is formed at the top surface of the concrete to retard moisture loss; this seal can be made from paraffin wax or adhesive aluminum foil tape. Strain monitoring of the inner ring by both strain gauges is monitored for a sudden ($30 \mu\epsilon$ minimum) decrease; this drop in strain is indicative of concrete cracking. Visual inspection of the specimens and the strain read out shall be completed at intervals not exceeding 3 days. The drying procedure shall continue for a minimum of 28 days, unless cracking occurs prior to 28 days. Using the measured values along with the equations in the method, the following is reported: mixture properties and proportions, type and duration of curing, daily ambient temperature and humidity for the test environment, plots of the steel ring strain vs. specimen age for each specimen, average age at cracking, age when tests were terminated for specimens that did not crack, average initial strain, average maximum strain, plots of net strain vs. square root of elapsed time for each specimen, and the average stress rate at cracking or at the time the test was terminated if the specimen did not crack.

The method provides an interpretation table for the acquired results that is reproduced in Table 9.

Table 9. Potential for cracking classification adapted from ASTM C1581.

Net Time-to-Cracking, t_{cr} (days)	Average Stress Rate, S (MPa/day)	Average Stress Rate, S (psi/day)	Potential for Cracking
$0 < t_{cr} \leq 7$	$S \geq 0.34$	$S \geq 50$	High
$7 < t_{cr} \leq 14$	$0.17 < S < 0.34$	$25 < S < 50$	Moderate – High
$14 < t_{cr} \leq 28$	$0.10 \leq S < 0.14$	$15 \leq S < 25$	Low – Moderate
$t_{cr} > 28$	$S < 0.10$	$S < 15$	Low

A summary of the approximate costs associated with implementing ASTM C1581 is presented in Table 10.

Table 10. Summary of required equipment and approximate costs using ASTM C1581.

Non-Consumables – Approximate Cost		Consumables – Approximate Cost		
<ul style="list-style-type: none"> • Temperature/humidity sensor/logger – \$90 (similar to HOBO UX100-003) • Strain gauge data acquisition system – \$2,900 (similar to CAS dataTaker DT80) • Computer and software¹ – \$0 - \$500 • Non-absorptive bases (3) – \$160 (24 in. x 24 in. x 3/8 in. UHMW) • Steel inner rings² – \$5,000 • PVC outer ring³ – \$2,500 • Wax melting pot and chip brush – \$40 	<ul style="list-style-type: none"> • Strain gauges –\$60 (similar to OMEGA KFH-3-120-C1-11L1M2R; if careful, these could be reused for multiple tests) • Specimen sealant – \$5 (paraffin wax) 	Total Approximate Cost: \$10,800 - \$11,300		
≤ 30 Days	Concrete	≤ \$30,000	Uncomplicated	No Hazards
✓	0.5 in. Nominal Maximum Aggregate Size	✓	✓	✓

¹The computer system would only be required if a local terminal was desired. The dataTaker DT80 data logger comes preinstalled with “dEX” software that will log and display real-time sensor information if connected to a network, or can be configured as a standalone device to act as a web server (to be accessed as a website).

²The inner steel ring specified would need to be machined from Schedule 120 14 in. diameter structural steel tubing (1+ inch thick wall thickness) that would need to be machined down; not only is this size pipe custom order only, it is typically only available in 20 ft lengths.

³The outer ring specified would need to be machined from Schedule 80 18 in. diameter PVC pipe (15/16 inch thick wall thickness) that would need to be machined down; not only is this size pipe custom order only, it is typically only available in 20 ft lengths.

Drawbacks of the Method:

The main drawback of ASTM C1581 is the size of the concrete ring; this limits the maximum aggregate size to 0.5 in. which dramatically limits the number of FDOT approved mixes that can be used in this method. Additionally, application of the strain gauges requires precision and attention to detail, but an application jig can make this step more accurate. Alternatively, using a three-gauge strain rosette would may imprecision of application to be accounted for.

3.2.2. AASHTO T 334

AASHTO T 334 – *Standard Method of Test for Estimating the Cracking Tendency of Concrete* [31] is a method that is very similar to ASTM C1581. The largest benefit to utilizing AASHTO T 334 over ASTM C1581 is that the specimen thickness is twice that of the specimens in ASTM C1581; and therefore, can accommodate aggregates with a nominal maximum diameter larger than 0.5 in. As the methods are very similar, Table 11 provides a summary of differences provided to highlight the major discrepancies between the two methods.

Table 11. Summary of technical differences between ASTM C1581 and AASHTO T 334.

Testing Parameter	ASTM C1581	AASHTO T 334
Inner steel ring size	13 in. dia. x 0.5 in. thick x 6 in. tall	12 in. x 0.5 in. thick x 6 in. tall ¹
Outer ring inner diameter	16 in. dia. PVC, Steel, or other non-absorptive	17.8 in. dia. Allowed to be 1/8 in. polyethylene sheet.
Strain gauges	Two – diametrically opposed	Four – orthogonally located; one mounted to unrestrained steel for temperature compensation
Base material	Non-absorptive, non-reactive material	Resin-coated, or polyethylene-coated plywood
Curing temperature	73.5°F ± 3.5°F	73.4°F ± 3.0°F
Ring securing mechanism	Bolts with eccentric washers	Central hold-down device; not specified
Required number of specimens	Three	Two
Consolidation	2 layers, rodded or vibrated	3 layers, rodded preferred
Top specimen seal	Paraffin wax or aluminum tape	Caulked plastic film
Crack characterization	Visual notation of crack presence	Measure crack widths across the height of the ring at 1.5 in., 3.0 in. and 4.5 in. from the base to determine average.
Interpretation of results	See Table 9 above.	None.

¹Extra strong steel pipe (12.75 in. OD x 0.5 in. thickness) can be substituted.

Based on the differences outlined in Table 11, the AASHTO T 334 method is less restrictive with regards to acquiring materials to making the molds, additionally the number of specimens is reduced. Due to this, the costs associated with performing the method can be dramatically reduced due to being able to use more widely available materials for the mold materials, as described in Table 12.

Table 12. Summary of required equipment and approximate costs using AASHTO T 334.

Non-Consumables – Approximate Cost		Consumables – Approximate Cost		
<ul style="list-style-type: none"> • Temperature/humidity sensor/logger – \$90 (similar to HOBO UX100-003) • Strain gauge data acquisition system – \$2,900 (similar to CAS dataTaker DT80) • Computer and software¹ – \$0 - \$500 • Non-absorptive bases (2) – \$80 (24 in. x 24 in. x ½ in. phenolic coated plywood; this would be reusable if proper care is taken) • Steel inner rings² – \$1,500 • Outer rings³ – \$100 • Central hold-down device⁴ – \$100 • Crack comparator card – \$5 	<ul style="list-style-type: none"> • Strain gauges –\$80 (similar to KFH-3-120-C1-11L1M2R; if careful, these could be reused for multiple tests) • Specimen sealant – \$5 (caulk) • Polyethylene sheeting – \$2 	Total Approximate Cost: \$5,000 - \$5,500		
≤ 30 Days	Concrete	≤ \$30,000	Uncomplicated	No Hazards
✓	~1.0 in. Nominal Maximum Aggregate Size ²	✓	✓	✓

¹The computer system would only be required if a local terminal was desired. The dataTaker DT80 data logger comes preinstalled with “dEX” software that will log and display real-time sensor information if connected to a network, or can be configured as a standalone device to act as a web server (to be accessed as a website).

²Using a Schedule 80 12 in. nominal steel pipe would be more cost effective than most other options; these pipes are relatively well-stocked through online distributors. However; this would make the cross-section of the specimen smaller and may necessitate a smaller maximum aggregate; this is not noted in the specification, but it is a concern with larger aggregate. The pipe would need to be cut down to 6 in. length rings, and have the inside and outside machined smooth.

³The outer ring are allowing the be 1/8 in. thick 6 in. tall polyethylene plastic sheet; other alternatives would be PVC pipes; however the costs for the polyethylene allow for 10-20 replacements before using PVC becomes economically viable.

⁴A central hold down device is prescribed but not described; eccentric washers on the inside of the inner ring similar to the ones noted in ASTM C1581 could work.

Drawbacks of the Method:

The main drawback of AASHTO T 334 is the size of the concrete ring; this limits the maximum aggregate size to approximately 1.0 in.; the use of a standard sized Schedule 80 12 in. steel pipe is allowed, but this reduced the cross section of the specimen from 3 in. to 2.625 in. While the method does not address this, the reduction in specimen size may necessitate a reduction in nominal maximum aggregate size. Additionally, application of the strain gauges requires precision and attention to detail, but an application jig can make this step more accurate.

Alternatively, using a three-gauge strain rosette may allow imprecision of application to be accounted for.

3.2.3. AASHTO T 363

AASHTO T 363 – *Standard Method of Test for Evaluating Stress Development and Cracking Potential due to Restrained Volume Change Using a Dual Ring Test* is a method similar to the previous two methods, but utilizes two metal restraining rings and imposes a temperature variation on the specimen rather than transient curing/evaporation [32]. This method essentially combines a standard ring test above with a semi-adiabatic test method. Therefore, the equipment and procedure are more involved and expensive than the previously described ring methods.

This procedure requires strain gauges mounted orthogonally on the inside and outside walls of concentric Invar steel rings with dimensions of 11.5 in. I.D. x 13 in. O.D. x 3 in. tall and 16 in. I.D. x 17.5 in. O.D. x 3 in. tall located on a resin- or epoxy-coated plywood base as shown in Figure 10. Thermocouples should be attached near the strain gauges to monitor specimen and ring temperature must be done in addition to ambient temperature monitoring. The rings and base are then placed into a well-insulated chamber. Once the concrete is placed in the rings, it is consolidated in two layers then finished, and a temperature control system is placed on the finished specimen. The temperature control system is not directly specified, but one that has been found to work is a 28 L programmable water bath system with an ethylene glycol water mixture circulating in a looped copper coil. This system must allow temperature control from -10°C to 30°C with an operating rate of at least 2°C/hr.

The specimen is held at 23°C ± 1°C for 2, 4, or 7 days then reducing the temperature at 2°C/hr until cracking is indicated by strain relief in the strain gauges or until the lower temperature limit is reached. Instantaneous strain decreases of approximately 20 µε in one or more gauges indicates cracking. Three specimens must be performed (2-day cure at 23°C, 4-day cure at 23°C, and 7-day cure at 23°C); using the equations presented within AASHTO T 363, the residual stress in the specimens are plotted versus time along with specimen temperature versus time, and then reporting the time-to-cracking, if the specimen cracks. Table 13 provides a summary of the approximate costs associated with performing AASHTO T 363 on a single concrete mix design; it should be noted that the specification appears to be written to indicate that a single test is performed at once, meaning that one mix design must be mixed three times (one set of rings, rather than a single concrete mix and three sets of rings).

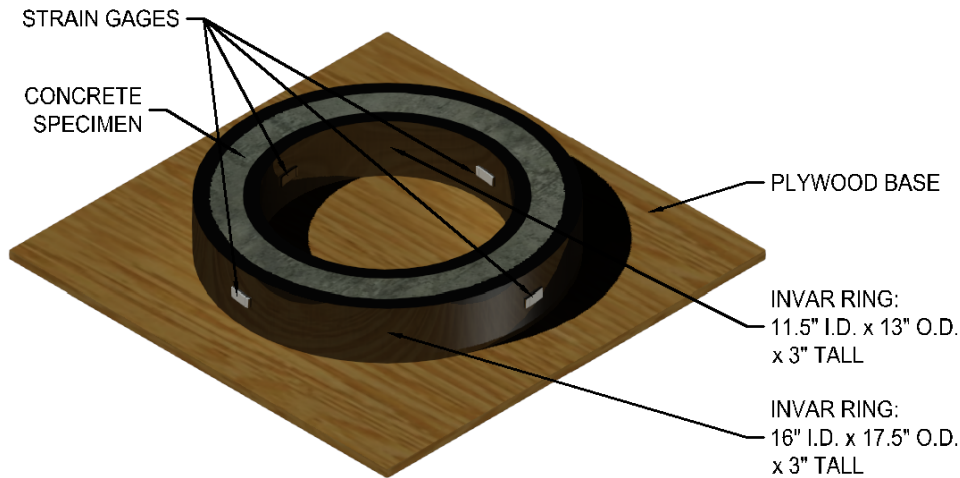

Figure 10. Initial layout of dual-ring test from AASHTO T 363.

Table 13. Summary of required equipment and approximate costs using AASHTO T 363 assuming one specimen is tested at a time rather than three.

Non-Consumables – Approximate Cost		Consumables – Approximate Cost		
<ul style="list-style-type: none"> Strain gauge and thermocouple data acquisition system – \$4,000 (similar to CAS dataTaker DT85) Non-absorptive base – \$80 (24 in. x 24 in. x ½ in. phenolic coated plywood; this would be reusable if proper care is taken) Computer and software¹ – \$0 - \$500 Invar rings² – \$4,000 - 8,000 Ring Spacers³ – \$100 Refrigerated recirculating water bath – \$5,500 (similar to Polyscience AD28R-30-A11B), tubing with fittings – \$100, and ethylene glycol – \$160/5 gallons Rigid insulation – \$40 		<ul style="list-style-type: none"> Low coefficient thermal expansion strain gauges –\$80 (similar to KFH-3-120-C1-11L1M2R; if careful, these could be reused for multiple tests) Thermocouple extension wire – \$65 (similar to Omega EXTT-TI-20-SLE-15M) for 50 feet of wire 		
Total Approximate Cost:		\$14,200 - \$19,000		
≤ 30 Days	Concrete	≤ \$30,000	Uncomplicated	No Hazards
✓	~0.5 in. Nominal Maximum Aggregate Size	✓	✓	✓ ⁴

¹The computer system would only be required if a local terminal was desired. The dataTaker DT85 data logger comes preinstalled with “dEX” software that will log and display real-time sensor information if connected to a network, or can be configured as a standalone device to act as a web server (to be accessed as a website).

²Prices for invar rings are not immediately available, the rings would need to be custom fabricated. The average costs for the invar metal in plate (~\$11/in.³) and rod (\$24/in.³) stock were used to estimate the material cost of approximately \$2,500 - \$5,000 with additional costs allotted for forging and machining the rings to final size.

³A device for locating the invar rings is recommended but not described; the specification recommends “spacers” without further detail.

⁴Ethylene glycol can be toxic if ingested in large amounts; however, other methods of contact (skin, eyes, etc.) are less irritating than portland cement.

Drawbacks of the Method:

The main drawback of AASHTO T 363 is the size of the concrete ring; this limits the maximum aggregate size to approximately 0.5 in. Additionally, if all curing conditions (2-day, 4-day, and 7-day cure) specimens were to be fabricated from the same concrete placement, the total costs associated would exceed the \$30,000 limit. This is due to the high cost of the Invar rings, additionally with three concurrent specimens being cooled at different temperatures, three circulating baths would be required at approximately \$5,000 each for fully programmable water baths.

3.2.4. Cracking Frame

In addition to ring specimens, test methods have been developed to evaluate prismatic concrete specimens for cracking tendency. The most common of this type is generally referred to as the cracking frame. In the method, a prism of concrete (with dovetailed ends) is cast into formwork to have a consistent cross-section in the middle. The dovetailed ends of the specimen are cast into steel blocks or crossheads which are connected with Invar connecting rods to provide restraint as shown in Figure 11 developed by [33]. The cracking frame tests do not have codified specifications, so the general testing regime developed is outlined below.

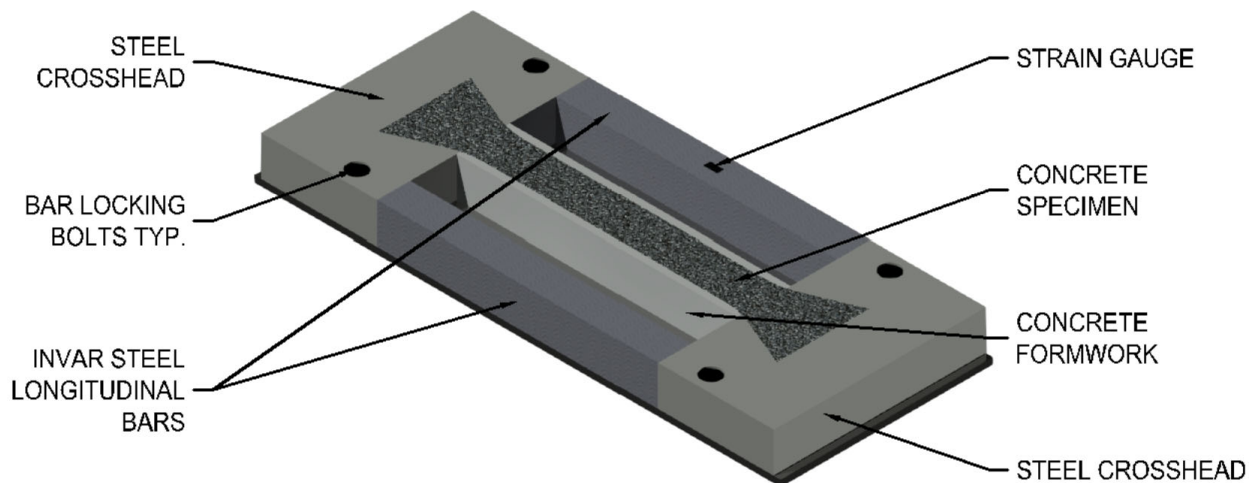

Figure 11. General testing setup for concrete cracking frame.

There have been multiple iterations of cracking frames that have been developed. The most basic form shown in Figure 11 utilized a 4 in. x 4 in. (10 cm x 10 cm) and later a 6 in. x 6 in. (15 cm x 15 cm) square cross-section with a specimen length of 1 m (39 inches). The Invar longitudinal bars providing the restraint are of approximately the same cross-section as the

concrete specimen. The restraint bars have a thermal expansion coefficient of approximately 1×10^{-6} in./in. compared to approximately 12×10^{-6} in./in. for standard steel, this allows for little thermal effects. Strain gauges are mounted to the Invar bars to measure the stress induced by the shrinking concrete specimen. The strain in the Invar bars is measured along with temperature over time and plotted; as the heat of hydration progresses, compressive strain increases in the specimen which induces tensile stress in the restraint bars. At 18 hours after casting, the ambient air temperature is reduced at a rate of $2^\circ\text{C}/\text{hr}$ and as the temperature begins to fall, the concrete specimen begins to relax and shrinkage inducing compressive strain in the restraining bars. At some point in time, the concrete will crack, releasing some of the strain in the bars, an example is shown in Figure 12. Lower temperatures recorded prior cracking indicate a concrete that is more resistive to cracking compared to cracking at higher temperatures.

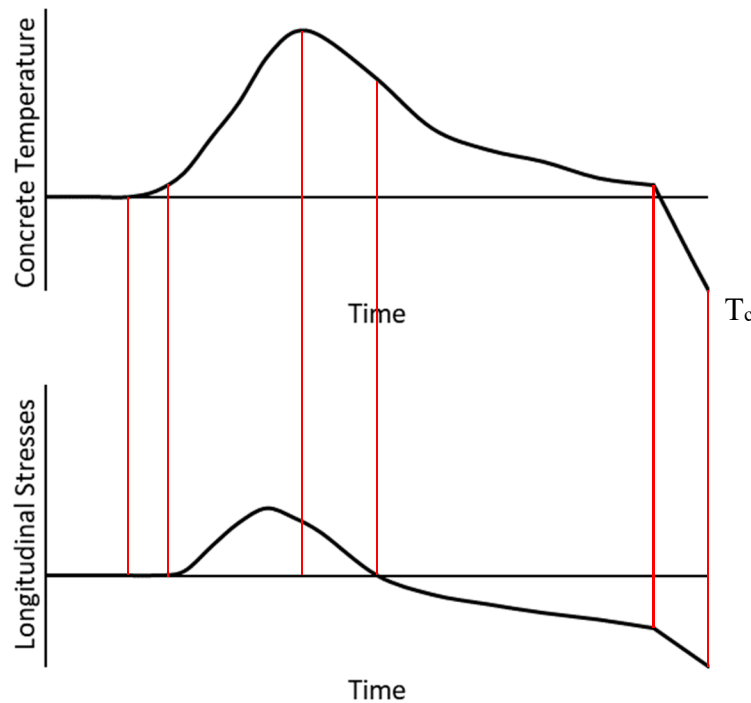

Figure 12. Typical plot of cracking frame stress development with time and temperature.

There is a separate variant of the cracking frame test where one of the crossheads is mechanically actuated such that when 1 micron of length change is measured, the crosshead adjusted to return the specimen to the original length. This return to the original length imposes more complete restraint in the system and is composed on carbon fiber rods, stepper motors, a track for the crosshead to move on, load cells, and optionally heating/cooling systems for the formwork to impose match curing or separate alternate conditions. For the purposes of this review, only the costs associated with the more basic testing frame will be investigated and presented in Table 14.

Table 14. Summary of required equipment and approximate costs using a basic cracking frame.

Non-Consumables – Approximate Cost		Consumables – Approximate Cost		
<ul style="list-style-type: none"> • Invar restraint rods – \$30,000 - \$65,000¹ • Dovetail cross heads – \$6,000 - \$8,000² • Computer and software³ – \$0 - \$500 • Strain gauge and thermocouple data acquisition system – \$2,900 (similar to CAS dataTaker DT80) • Low coefficient thermal expansion strain gauges –\$80 (similar to KFH-3-120-C1-11L1M2R; if careful, these could be reused for multiple tests) • Walk-in environmental chamber – \$25,000 • Rigid form insulation – \$40 • Thermocouple extension wire – \$65 (similar to Omega EXTT-TI-20-SLE-15M) for 50 feet of wire 		<ul style="list-style-type: none"> • Form release – \$10 		
Total Approximate Cost: \$64,000 - \$102,000				
≤ 30 Days	Concrete	≤ \$30,000	Uncomplicated	No Hazards
✓	✓	X	X	✓

¹Invar rods of 4 in. x 4 in. or 6 in. x 6 in. cross section in 48 in. lengths are not widely available. A 3-foot long section of 4 in. diameter rod (which is too short, and small in cross-section) was used to estimate the costs for two 4 in. x 4 in. x 48 in. bars (\$30,000) or two 6 in. x 6 in. x 48 in. bars (\$65,000).

²4 in. thick A-36 steel plate can be purchased from online retailers for approximately \$350/ft². Additional machining costs would be needed to produce dovetail recesses. 6 in. Steel plate is approximately \$475/ft².

³ The computer system would only be required if a local terminal was desired. The dataTaker DT85 data logger comes preinstalled with “dEX” software that will log and display real-time sensor information if connected to a network, or can be configured as a standalone device to act as a web server (to be accessed as a website).

Schindler et al. 2019 [34] describes a modified testing apparatus that utilizes an insulated formwork jacket that integrates the dovetail crossheads and is plumbed to provide temperature adjustment (rather than an environmental chamber). This apparatus adapted from Springenschmid et al. 1995 utilizes two approximately 4 in. diameter x 48 in. long invar bars as the restraining elements. These modifications would likely bring the final costs closer to \$40,000 - \$75,000 but still require custom fabrication of insulated thermal jackets, restraining systems, and a digitally-controlled heating/cooling recirculation system.

Drawbacks of the Method:

The main drawback of the cracking frame method is cost of the Invar rod/bar stock required for the restraint system. At approximately \$15 - \$25 per in³, the requirement of having bars having similar cross-section to the specimen make these elements have a minimum cost of

approximately \$25,000 without machining costs. Utilizing methods to induce more restraint by incorporating a movable cross-head dramatically increases the testing costs associated with the method.

3.2.5. NT Build 433

The Nordtest 433 is a restrained shrinkage ring test that utilizes two steel rings with inner fins that restrain the concrete specimen more than the ASTM or AASHTO test methods [35]. The concrete specimen is placed between the restraining rings and onto a table atop a weighing device. A transparent funnel is placed over the concrete specimen and is connected to a fan that provides an air velocity of approximately 15 ft/s through a 4-in. diameter duct as shown in Figure 13. Three replicate specimens are cast and tested simultaneously in a room that is maintained at $21^{\circ}\text{C} \pm 1^{\circ}\text{C}$ and $43\% \pm 3\%$ RH for the duration of the testing period (20 hours). For the first 6 hours of the test, the temperature of the specimen, weight of the specimen, and ambient temperature/humidity of the air must be recorded continuously in addition to visual inspection and recording of any observable crack development.

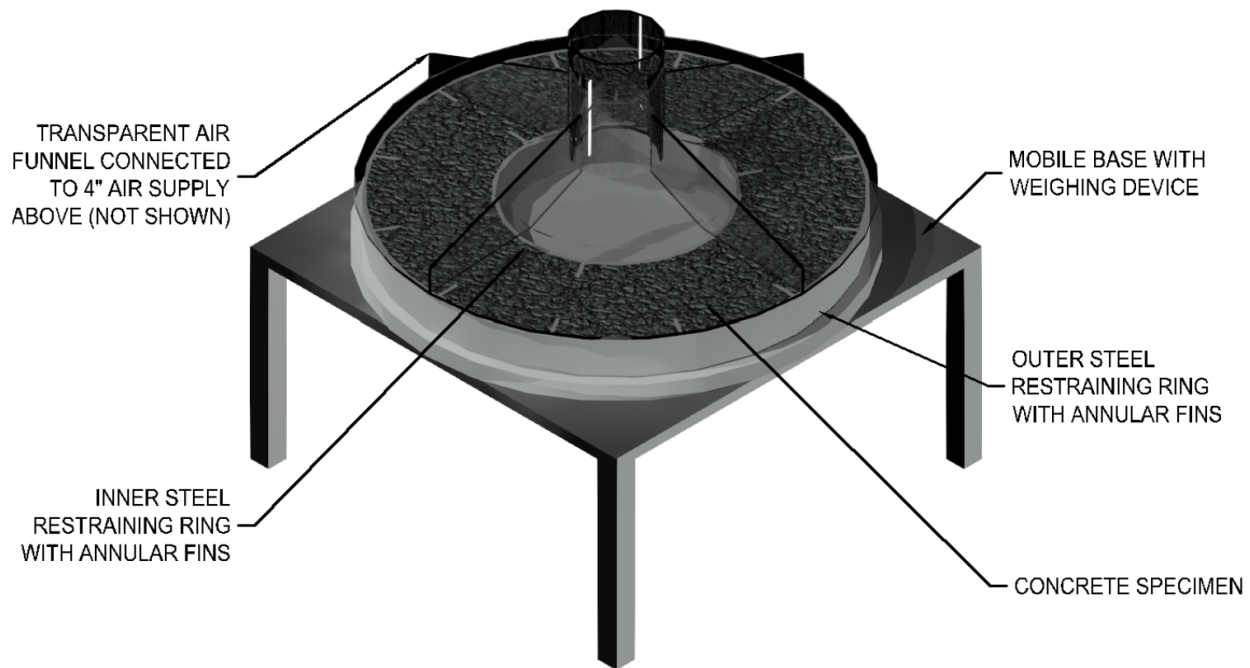

Figure 13. General test setup for cracking frame described in NT Build 433.

Following the 20-hour testing duration, concentric rings are drawn on the specimen to divide the thickness of the specimen into three – 50-mm (2-inch) thick rings. Any cracks that propagate through these concentric rings are measured to the nearest 0.02 mm in width by using a magnifying lens; the accumulated width of the cracks passing through each ring is then added up for each of the two concentric rings, and the final accumulated crack width is the average of the two accumulated sums. The average crack width for each specimen is then averaged between the three specimens to get the “crack index” rounded to the nearest 0.1 mm. This crack index is then used as a relative (within laboratory) measure as a comparative metric.

Table 15. Summary of required equipment and approximate costs using NT Build 443 with three specimens.

Non-Consumables – Approximate Cost		Consumables – Approximate Cost		
<ul style="list-style-type: none"> • Steel restraining rings – \$1,000 - \$3,000 with fabrication • 100x magnifying loupe (0.02 mm gradation or less) – \$250 • Computer – \$500 • Platform scale and thermocouple data acquisition system – \$2,900 (similar to CAS dataTaker DT80) • Ambient air temperature and humidity logger – \$125 (similar to HOBO UX100-011A) • Rolling tables – \$400 (similar to Webstaurantstore.com item 600T2424G with caster set) • Platform scale with electrical output – \$1,600 (similar to OMEGA LSC6400-2424-250SS) • Hot-wire anemometer – \$250 (similar to PCE-instruments PCE-423) • Ducting and 100 CFM fans – \$3,000 • Room humidifier with controller (and optionally dehumidifier) to control RH between 40 - 46% – \$5,000 		<ul style="list-style-type: none"> • Thermocouple extension wire – \$65 (similar to Omega EXTT-TI-20-SLE-15M) for 50 feet of wire • Form release – \$10 		
Total Approximate Cost: \$15,200 - \$17,200				
≤ 30 Days	Concrete	≤ \$30,000	Uncomplicated	No Hazards
✓	~0.625 in. Nominal Maximum Aggregate Size	✓	✓	✓

Drawbacks of the Method:

The main drawback of NT Build 433 is the short duration of testing (20 hours) will only allow the observance of plastic shrinkage and minimal amounts of chemical, autogenous, and drying shrinkage. Furthermore, the testing method is only a visual evaluation of the crack widths without measurement of induced stress on the rings. Therefore, the stress in the concrete

specimens at the time of cracking is unknown. Lastly, the height of the ring is approximately 2 in. limiting the nominal maximum aggregate size to approximately 0.625 in. (16 mm).

3.2.6. ASTM C1579

ASTM C1579 - *Standard Test Method for Evaluating Plastic Shrinkage Cracking of Restrained Fiber Reinforced Concrete (Using a Steel Form Insert)* is a method to evaluate the efficacy of fiber reinforcement on plastic cracking mitigation of comparable unreinforced concrete [36]. As such, this method has restrictions on the application as it is meant to specifically evaluate the benefit of a prescribed fiber reinforcement dosage, and only for the first 24 hours after placement.

This method specifies that a fiber-reinforced concrete mixture is placed into a mold with restraint and crack-inducing risers as shown in Figure 14, along with companion specimen panels that are identical to the mix design without the fiber reinforcement. Duplicate specimens of each type are placed into molds and put into an environmental chamber along with pans of water to monitor the evaporation rate of the environment, and conditioned air is blown over the panels until the mixtures reach final setting at which point the evaporative environment is stopped and the specimens are covered. At 24 hours, the crack widths for each specimen are measured and the reduction of average crack width between the fiber-reinforced concrete and control concrete is computed.

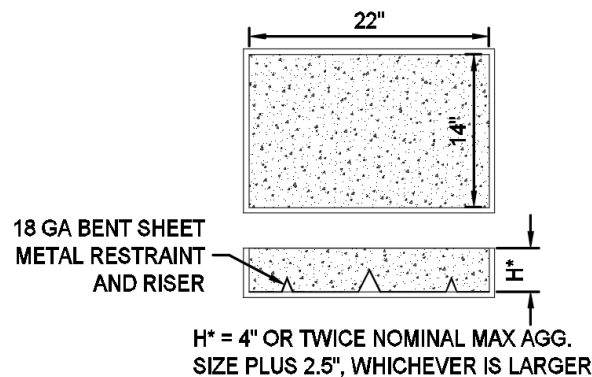

Figure 14. Concrete panel mold specifications. Adapted from ASTM C1579.

The evaporative environment is described as an environmental chamber capable of maintaining $36^{\circ}\text{C} \pm 3^{\circ}\text{C}$ and $30\% \pm 10\%$ RH during the test; inside the chamber is a fan capable of providing air speed of at least 4.7 m/s over the surface of the specimens and water pans, along with scales for measuring the water loss from the water pans. One such example of the testing set up is shown below Figure 15.

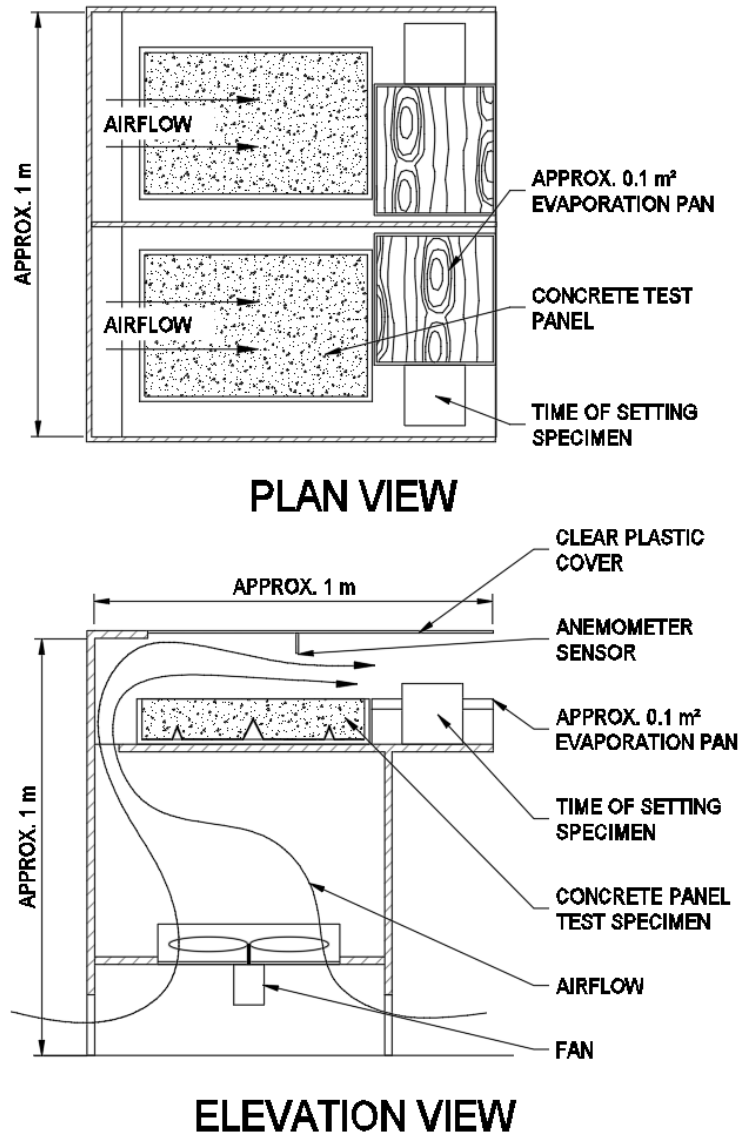

Figure 15. Example of a specimen cabinet that must be inside an environmental chamber to test two concrete panels in accordance with ASTM C1579.

Due to the specifications of this test method, two panels must be cast for each control concrete mixture as well as two panels for each test mixture evaluated in tandem. Therefore, the associated costs for the method are for evaluating four panels at once. A summary of the approximate upfront and “per-evaluation” costs for ASTM C1579 are presented in Table 16.

Table 16. Summary of required equipment and approximate costs using ASTM C1579.

Non-Consumables – Approximate Cost		Consumables – Approximate Cost		
<ul style="list-style-type: none"> • Walk-in environmental chamber – \$25,000 • Concrete molds w/ bent steel inserts (4) – \$3,000 (assumed stainless steel) • Variable speed fans (2) – \$1,000 (2,000 CFM fans with variable speed controllers) • Computer¹ – \$0 - \$500 • Data acquisition system – \$4,000 (similar to CAS dataTaker DT85) • Combination air velocity, humidity, and temperature sensor arrays (4) – \$1,800 (similar to Degree Controls, Inc FH-2000) • Platform scales with electrical output – \$2,500 (similar to Arlyn Scales 10 lb bench scales; 4 required; 1 for each panel) • 100x magnifying loupe (0.05 mm gradation or less) – \$250 • Evaporation pans – \$150 • Time of setting molds – \$0 - \$600 (depending on whether FDOT uses steel molds, cylinder molds, or already has molds) • Time of setting penetrometer – \$0 - \$1,400 (depending on whether FDOT already has this equipment or not) 	<ul style="list-style-type: none"> • Form release – \$10 • Polyethylene sheeting – \$10 	Total Approximate Cost: \$37,750 - \$40,250		
≤ 30 Days	Concrete	≤ \$30,000	Uncomplicated	No Hazards
✓	✓ ²	X	✓	✓

¹ The computer system would only be required if a local terminal was desired. The dataTaker DT85 data logger comes preinstalled with “dEX” software that will log and display real-time sensor information if connected to a network, or can be configured as a standalone device to act as a web server (to be accessed as a website).

² This test method is specifically designed to determine the effectiveness of fiber reinforced concrete in comparison to comparable mixes without fiber reinforcement. Therefore, it is not directly applicable to the majority of concrete mixes; however, it may be able to be modified.

Drawbacks of the Method:

This method requires the use of a duplicate specimens and companion mixes all to be located in an environmental chamber. Similar to the NT Build 433 test method, a drawback of this method is the short duration of testing (24 hours) will only allow the observance of plastic shrinkage and minimal amounts of chemical, autogenous, and drying shrinkage. This testing method is only a visual evaluation of the crack widths without measurement of induced stress on the specimens. Therefore, the stress in the concrete specimens at the time of cracking is unknown. Additionally, the scope of the method is only applicable for fiber-reinforced concrete in comparison to the same mixture composition without fiber reinforcement.

3.3. UNRESTRAINED SHRINKAGE

Unrestrained shrinkage tests measure the shrinkage of concrete without the use of external (steel rings, dovetail crossheads, or bent steel risers) or internal (fiber reinforcement, rebar, or mesh) reinforcement. Instead, the concrete is free to expand and contract and is only limited by the intrinsic limitations of the material properties (tensile strength, angularity and quantity of aggregate, and water content, amongst other factors). Due to this, unrestrained shrinkage, compared to restrained shrinkage, is less likely to result in cracking failure. However, cracking due to drying shrinkage and plastic shrinkage are still possible.

3.3.1. ASTM C157/AASHTO T 160

ASTM C157 and AASHTO T 160 are dual listed specifications that cover the “determination of the length changes that are produced by causes other than externally applied forces and temperature changes” of concrete specimens produced exposed to controlled temperature and humidity [37], [38]. This method involves casting 3 in. x 3 in. x 11.625 in. or 4 in. x 4 in. x 11.625 in. concrete prism specimens with embedded gauge studs in the ends of the prisms. Following demolding of the specimens, an initial length measurement is taken and specimens are initially cured for until 28 days in lime-saturated water at $73^{\circ}\text{F} \pm 3^{\circ}\text{F}$ ($23^{\circ}\text{C} \pm 2^{\circ}\text{C}$) when a second measurement is made. Once the initial curing period is over, the specimens are split into a group for moist-curing and a group for air-curing; the moist-cured specimens are returned to saturated lime water and periodically measured at 8, 16, 32, and 64 weeks after the mix date. The air-cured specimens are placed in a drying room such that each specimen has at least 1 in. of space on all sides for air circulation, with minimal support (to allow air circulation underneath the specimens), and measurements are to be taken at 4, 7, 14, and 28 days after the initial curing period, and then again at 8, 16, 32, and 64 weeks. The condition in the air-drying room shall be at $73^{\circ}\text{F} \pm 3^{\circ}\text{F}$ ($23^{\circ}\text{C} \pm 2^{\circ}\text{C}$) and $50\% \pm 4\%$ relative humidity.

The method mentions three replicate specimens in the precision and bias statement; therefore, it is recommended that the minimum number of specimens created for each evaluation is six, three replicates for air-storage and three specimens for moist-storage. A summary of the approximate costs associated with a single evaluation (six specimens) is presented in Table 17.

Table 17. Summary of required equipment and approximate costs using ASTM C157 or AASHTO T 160 with six specimens.

Non-Consumables – Approximate Cost		Consumables – Approximate Cost		
<ul style="list-style-type: none"> Concrete Molds – \$1,100 - \$1,500 (3 in. x 3 in. or 4 in. x 4 in. specimens) Length comparator with 10 in. Invar reference bar – \$1,200 Drying room – \$1,000 - \$2,000¹ Drying room racks – \$65 ea (Websturauntstore.com item 465C1824KE5 would hold 5 mixes) Digital thermo-hygrometer with wet bulb and logging capability² – \$500 - \$1,000 400 mL low-form Griffin flask for monitoring evaporation – \$80 (sold in packs of 6 – 12) 		<ul style="list-style-type: none"> Gauge studs – \$9 		
Total Approximate Cost: \$4,000 - \$6,000				
≤ 30 Days	Concrete	≤ \$30,000	Uncomplicated	No Hazards
X	✓	✓	✓	✓

¹ Most typical air-conditioned spaces can be modified to meet the qualifications of the standard (73°F ± 3°F and 50% ± 4% relative humidity) with the implementation of a small dehumidifier and/or humidifier and circulation fan, as necessary.

² This test method calls for a sling psychrometer or an Assmann psychrometer to measure the dry and wet bulb temperatures in the room twice a day for every working day. These psychrometers are antiquated and this verbiage has not been changed since the inception of the method in 1975 [39]. Digital thermo-hygrometers available currently can constantly measure and log dry and wet bulb temperature as well as relative humidity without needing human intervention and measurement; models are available with NIST traceable certificates of calibration.

Drawbacks of the Method:

The largest drawback of ASTM C157/AASHTO T 160 is that it cannot be completed in 30 days. The initial curing takes places over 28 days and then the air-cured and moist-cured specimens are separated. Therefore, differences due to drying shrinkage is not initiated until day 28. Additionally, the room requirements combined with the long duration of test method essentially makes a humidifier a necessary piece of equipment for at least part of the year (as in winter, the relative humidity drops below the acceptable level).

3.3.2. EN12390 – Part 16

The European Standard for Testing hardened concrete – Part 16: Determination of the shrinkage of concrete (EN 12390 – Part 16) describes a method for measuring the total shrinkage of concrete specimens in drying conditions. This method also prescribes a method for determining autogenous shrinkage of concrete [40]. In this method, prismatic or cylindrical concrete

specimens are cast with gauge points similar to ASTM C157; however, the location of the gauge points can be at the ends of the prisms, along one face, or in two separate planes depending on what type of shrinkage is being evaluated. The drying room has less stringent constraints than the drying room prescribed in ASTM C157 in that the relative humidity has a target value that is permitted to be between 50% - 70% and be accurate to within $\pm 5\%$, and the temperature has a range of $20^{\circ}\text{C} \pm 2^{\circ}\text{C}$.

The specification for this method was unavailable to the research team, therefore a full review of the method could not be completed, but inclusion of the method was deemed pertinent to the overall project should the FDOT choose to investigate this method further.

3.3.3. AASHTO T 336

The coefficient of thermal expansion (CTE) of concrete is not a direct measure of cracking tendency; however, when unrestrained thermal expansion is measured, this information can allow the inference about the likelihood of a material to crack in a restrained system. Concretes with higher coefficients of thermal expansion will experience higher levels of strain than concretes with lower coefficients of thermal expansion in the same thermal environment. AASHTO T 336 describes a method of measuring the coefficient of thermal expansion of a concrete cylindrical specimen under the most common service temperatures (10°C – 50°C) [41].

This method involves casting a standard 4 in. x 8 in. concrete cylinder and grinding the ends flush until the length is $7.0 \text{ in.} \pm 0.1 \text{ in.}$ Duplicate specimens are placed into measuring frames which houses a measuring device such as a linear variable differential transducer (LVDT) with a minimum resolution of 0.000005 in. The frame and specimen are submerged in a circulating water bath and cycled between 10°C and 50°C (50°F and 122°F) as shown in Figure 16. As the temperature of the water in the circulating bath is cycled through the temperature range several times, the difference in specimen length between 50°C and 10°C is measured with the LVDT and recorded alongside water temperature. The length difference, normalized by the original length of the specimen, is divided by the temperature differential to determine the mean coefficient of thermal expansion in the range of 10°C to 50°C . The measurement process can generally be completed in 48 hours after the cylinders are prepared and placed into the frame.

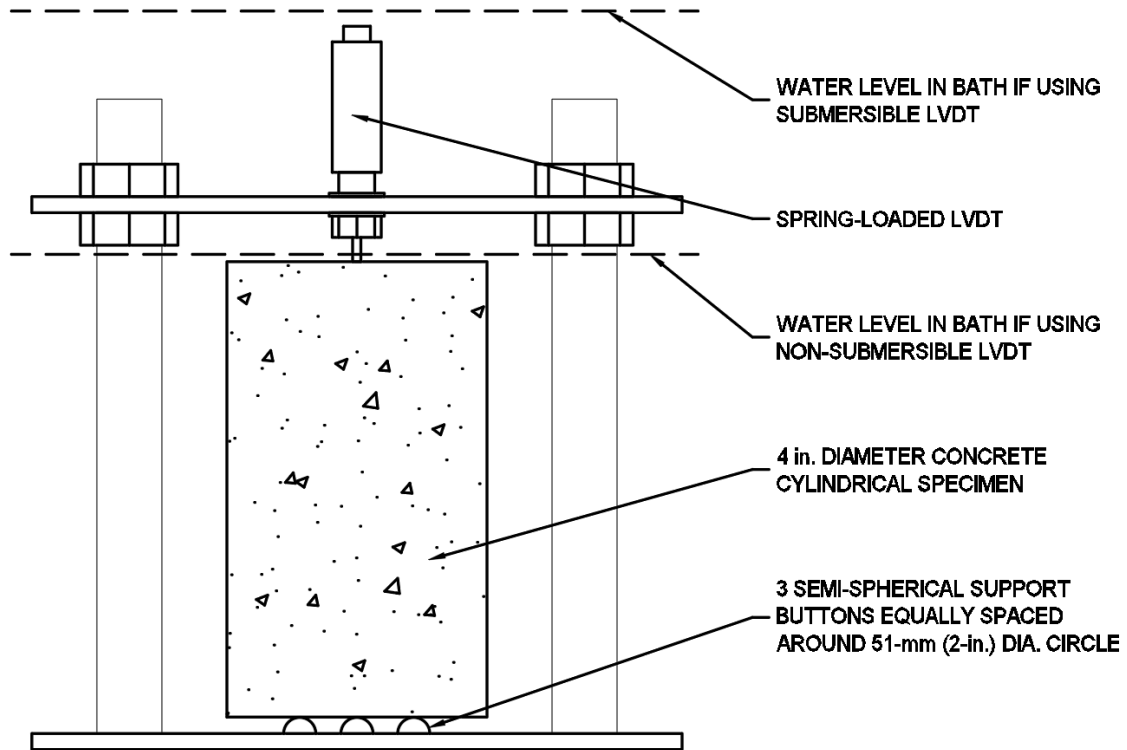

Figure 16. Schematic of a CTE setup as per AASHTO T 336.

Each frame of the CTE bath will need to be calibrated with standard materials in order to determine the bias associated with each frame so that the CTE determined can be corrected. These calibration specimens are typically made of well-characterized materials, and Grade 304 stainless steel, titanium, and nickel are listed as suitable calibration standards. These standards must have the CTE measured/calibrated (usually by an external laboratory or manufacturer). Additionally, the bath requires verification with NIST-traceable thermometers periodically. A summary of the approximate costs associated with performing this experimental method is presented below in Table 18.

Table 18. Summary of required equipment and approximate costs using AASHTO T 336.

Non-Consumables – Approximate Cost		Consumables – Approximate Cost		
<ul style="list-style-type: none"> • Programmable recirculating heated and cooled water bath – \$11,500 (similar to Polyscience model AP75R-20-A13D) • Stainless steel frames (2) – \$6,750 (similar to Gilson model HMA-114) • Submersible LVDTs (2) – \$1,300 (similar to OMEGA LD620-5) • Calibration specimen – \$1,600 - \$5,200 • Computer and software¹ – \$0 - \$8,000 • Data acquisition modules and chassis – \$1,500 - \$2,500 (similar to dataTaker DT821) 				
Total Approximate Cost: \$22,750 - \$35,250				
≤ 30 Days	Concrete	≤ \$30,000	Uncomplicated	No Hazards
✓	✓	✓	✓	✓

¹ The computer and software would be required to automate the process of changing the bath temperature; however, this is not necessary.

Drawbacks of the Method:

The drawbacks of AASHTO T 336 are that getting high quality data can be difficult due to a combination of effects of thermal, water, and corrosion effects on the sensitive electronics. The moving water and temperature swings combined with soaking alkaline concrete in tap water will cause corrosion issues on the frames, heating elements, and circulation pumps. Additionally, insulating the equipment may cause additional condensation issues on the LVDT. The temperature sensors of the circulating bath may not be sufficiently accurate which would require the use of RTDs or similar temperature measuring elements. Eliminating causes of errors can be a long and tedious process.

3.3.4. ASTM C827

ASTM C827 - *Standard Test Method for Change in Height at Early Ages of Cylindrical Specimens of Cementitious Mixtures* describes a method to track the height changes of a concrete specimen before final setting by using a system of magnifying lenses, a light source, and tracking grid [42]. In this method, fresh concrete specimens are placed on a surface in front of a board that has holes cut into it to allow a small amount of light through. Behind that board is another board with aligned focusing magnifying lens that focus the light onto a set of indicating charts approximately 15 feet from the light source. Into the fresh specimens small spheres are pressed into the surface such that a projected light shines across the top of the sphere, through the first set of holes, through the magnifying lens, and onto the indicating charts as shown in Figure 17. The

indicating charts are adjusted such that the initial reading is set to the center of the chart (0 displacement) and the changes in the volume of the concrete specimen cause the location of the sphere to shift up or down with respect to the indicating charts. The charts are measured to the nearest 0.1 in. every 5 minutes for the first 90 minutes, and every 10 minutes for the next 60 minutes, then every 20 minutes from that point forward until the concrete mixture has set.

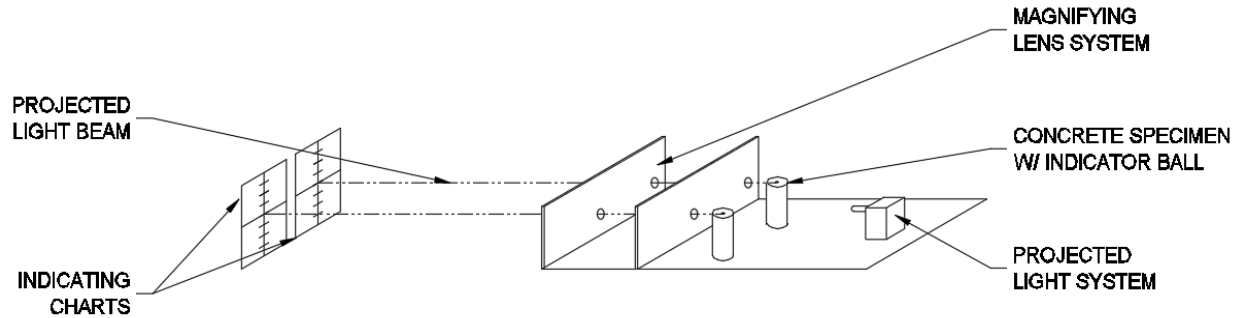

Figure 17. Test setup for ASTM C827.

Table 19. Summary of required equipment and approximate costs using ASTM C827.

Non-Consumables – Approximate Cost		Consumables – Approximate Cost		
<ul style="list-style-type: none"> • Light projection system – \$100 (light fixture base and light bulb) • Clear plastic heat shield between light and specimens, if necessary – \$0 - 40 (polycarbonate sheet) • Indicator spheres (approximate specific gravity 1.2) – \$15 (1/2 in. diameter nylon balls, 50 pack) • Magnifying lenses (relay lens with approximate focal length of 2 inches, and projection lens with approximate focal length of 1.625 inches) – \$500 - \$1,000 • Indicating charts – \$200 	<ul style="list-style-type: none"> • 6 in. x 12 in. cylinder molds (2) – \$5 	Total Approximate Cost: \$850 - \$1,350		
≤ 30 Days	Concrete	≤ \$30,000	Uncomplicated	No Hazards
✓	✓	✓	✓	✓

Drawbacks of the Method:

The largest drawback of ASTM C827 is that the test only measures unrestrained shrinkage of the concrete specimens prior to final setting; therefore, drying shrinkage and the majority of other shrinkage types cannot be determined. Additionally, this method requires constant (or near

constant) supervision during the entire setting of the concrete as readings need to be taken virtually constantly.

3.3.5. Existing Available Equipment

Gilson Company, Inc. sells a CTE system for \$21,500. This system comes with a circulating bath, water temperature conditioning unit, a single frame, LVDT, and a computer. In order to evaluate two specimens accurately, a second frame (\$3,390) and at least one verification specimen (\$1,620 for 304 stainless or \$5,150 for 410 stainless) would need to be purchased for a total price of \$26,510 to \$30,040. Gilson also offers an LVDT calibrator for \$650.

Pine Test Equipment also manufactures a CTE system; however, the pricing of the system is not public. They offer calibration standards in 304 stainless steel as well as titanium. This system does not come with a computer (but does have control software) and appears to have higher quality parts (submersible LVDT and machined/polished frames).

A piece of equipment developed using a similar procedure as ASTM C827 is manufactured by Schleibinger. This piece of equipment uses a cone-shaped mold of concrete, mortar, or paste on which a reflector is placed at the surface. The specimen is then placed onto a laser measuring device which tracks the height changes of the reflector over time to within 2 microns. The website ([Schleibinger Website](#)) does not provide cost information. On a separate note, this company also provides equipment for evaluating shrinking/cracking ring specimens (ASTM C1581).

3.4. OTHER METHODS

There are a number of shrinkage and cracking evaluation methods that have been developed for mortar testing rather than for concrete. In an effort to provide as much completeness to the review as possible, a short summary of these tests are presented below which may offer opportunities to be adapted to concrete specimens.

3.4.1. German Angle Test

In this method, a 2.75 in. 90° Channel that is 39 in. long is oriented as shown in Figure 18, the interior faces of the angle are cleaned and have bonding agent applied to them to assist with restraint. The specimens are then cast in place and monitored for cracking over a period of 180 days. Triplicate specimens are produced for each mixture evaluation. This method is described in detail by Emmons and Vaysburd, 1995 [43].



Figure 18. German angle test.

3.4.2. SPS Plate Test

A test method described by Poston et al. [44] is the SPS Plate test; in this method, a prismatic specimen is cast to have a 2 in. x 4 in. cross-section and is 52 in. long. This beam is cast on the backside of a C-channel, and is clamped at one end. As the specimen shrinks over time, curling is induced in the specimen and the tip deflects upward as shown in Figure 19; this tip deflection is measured over 28 days.

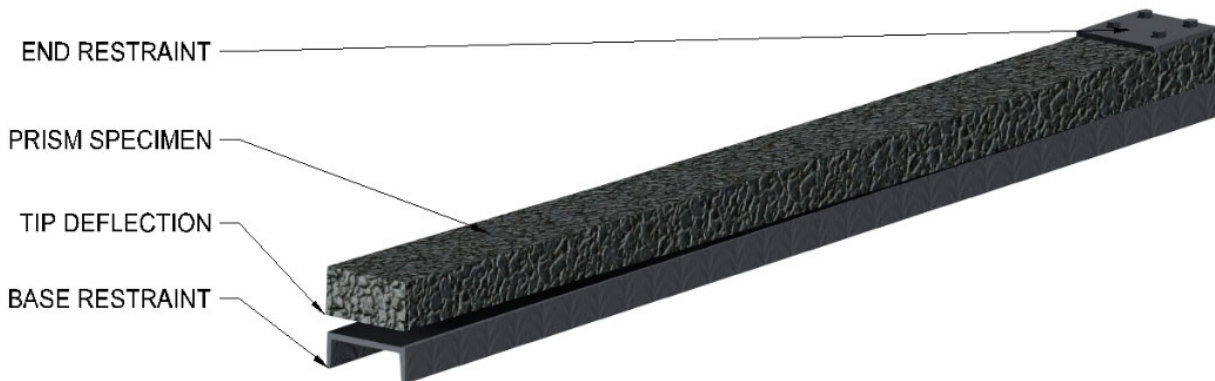

Figure 19. SPS plate test setup.

3.4.3. ASTM C596

ASTM C596 is a variant of ASTM C157 designed specifically to measure the drying shrinkage of cementitious mortars [45]. This method uses the same equipment as ASTM C157 and differs in that mortar bars are cured in the molds for 24 hours \pm 30 minutes then cured in saturated limewater until an age of 72 hours \pm 30 minutes. After this initial curing period, the bars are immediately placed in a drying environment and measured as per ASTM C157 to track drying shrinkage.

3.4.4. ASTM C1090

ASTM C1090 - *Standard Test Method for Measuring Changes in Height of Cylindrical Specimens of Hydraulic-Cement Grout* measures the height change of cylindrical specimens in the absence of an evaporative environment [46]. This method uses a micrometer to measure the height of a cylinder over the course of 28 days to track shrinkage in the height of a 3 in. x 6 in. grout cylinder. The cylinders are optionally placed in a sealed bag with a moist towel for the duration of the test to prevent evaporation and absorption of water and carbonation; or alternatively placed into a moist room with a plastic cover to prevent water dripping on the specimens.

3.5. SUMMARY

A summary of the available testing methods for measuring cracking tendency of concrete and the applicability to FDOT requirements for implementation is presented in Table 20. The cracking tendency of concrete is most directly evaluated by use of restrained shrinkage tests which impose tensile strain beyond the tensile strength of hydrating concrete. The unrestrained shrinkage tests give information about the likelihood of relative movement (and therefore likelihood of cracking can be *inferred*, but not directly quantified). Therefore, the restrained shrinkage tests are the most likely to result in quantifiable cracking tendency of concrete with unrestrained shrinkage results indicating likelihood of movement in the absence of restraint from factors such as reinforcement or adjacent structures.

Based on this, the restrained shrinkage tests do not meet all of the FDOT criteria; however, it is believed that a slight modification of AASHTO T 334 to allow for a larger cross-section (and therefore larger nominal maximum aggregate size) would facilitate an expedient development of a Florida Method of Test. Alternatively, a modification to disallow the use of a standard pipe as the mold, restricting the cross-section of the specimen to a minimum of 3 in. would also suffice.

Two of the unrestrained shrinkage tests meet the criteria; however, they are unlikely to result in quantifiable cracking and therefore should only be utilized as supplementary evaluation methods if desired.

Table 20. Summary of criteria for cracking test methods.

	≤ 30 Days	Concrete	≤ \$30,000	Uncomplicated	No Hazards	
Restrained	ASTM C1581	✓	0.5 in. Nominal Maximum Aggregate Size	✓	✓	✓
	AASHTO T 334	✓	~1.0 in. Nominal Maximum Aggregate Size	✓	✓	✓
	AASHTO T 363	✓	~0.5 in. Nominal Maximum Aggregate Size	✓	✓	✓
	Cracking Frame	✓	✓	X	X	✓
	NT Build 433	✓	~0.625 in. Nominal Maximum Aggregate Size	✓	✓	✓
	ASTM C1579	✓	✓ ¹	X	✓	✓
Unrestrained	ASTM C157/ AASHTO T 160	X	✓	✓	✓	✓
	AASHTO T 336	✓	✓	✓	✓	✓
	ASTM C827	✓	✓	✓	✓	✓

¹ This test method is specifically designed to determine the effectiveness of fiber reinforced concrete in comparison to comparable mixes without fiber reinforcement. Therefore, it is not directly applicable to the majority of concrete mixes; however, it may be able to be modified.

4. DURABILITY TESTING

4.1. BACKGROUND

Reinforced concrete structures are often exposed to harsh environments, yet the service life of these structures is expected to exceed 50 years or in some cases 100 years. As a result, establishing reliable methods to accurately measure durability, the ability of a structure to remain in service with minimal repair and maintenance for its design life, is essential for improving the design life of structures. While exposure sites for durability specimens are valuable for assessing the performance in real exposure conditions, these sites require long exposure times which are unacceptable for most material qualification testing. Research has shown that the transport properties of concrete are good indicators of durability for problems commonly encountered in Florida [47]–[53].

Concrete transport properties are dependent on the pore structure of the concrete and influenced by several factors including: materials, concrete mixture design, admixtures, curing practices, age, and construction techniques [49], [54]–[59]. Transport properties have traditionally been

improved through a reduction in the water-cementitious material ratio (w/cm) and/or use of supplementary cementitious materials (SCMs) [47], [60], [61]. A lower w/cm reduces the amount of water-filled porosity in the concrete from the time of mixing on throughout the life of the concrete. The total cementitious content and use of supplementary cementitious materials also plays a major role in the hydration and penetrability of concrete [49], [55], [58], [62], [63]. Older, more hydrated concrete will possess a more developed pore structure and lower permeability [49], [51], [54]. Concrete containing SCMs will generally have delayed hydration, thus more time is required to develop resistance to permeation [49], [59], [63]. SCMs reduce permeability through pore blocking and by continued chemical reaction to create additional hydration products that reduce the volume and connectivity of the concrete pore system. FDOT has traditionally used fly ash, slag cement, silica fume, ultra-fine fly ash, and metakaolin as SCMs to improve durability [64].

4.1.1. Chloride Durability

Chloride exposure is of particular concern in Florida due to the large amount of reinforced concrete structures on the coastline. Chloride ions cause corrosion of the reinforcing steel, which is the leading cause of deterioration in reinforced concrete structures. The volume of the corrosion reaction products is greater than that of the reactants, which results in a net volume increase that causes cracking in the surrounding concrete [62], [65]. Cracking produces easier pathways for the chloride ions to reach the reinforcing steel, thereby corroding more steel, and continuing the deleterious cycle. Steel corrosion, and subsequent formation of cracking in the concrete, results in reduced load capacity, serviceability, and aesthetics of the structure [47], [49], [65].

Many test methods have been developed to estimate the chloride durability of concrete, ranging from long-term exposure tests to electrical resistivity test methods. Test methods that simulate real exposure conditions with chloride solutions in which the chloride diffusion over time or corrosion potential is measured provide a good indication of performance, but are long-term test methods that require more than 30 days.

The salt ponding test (ASTM C1543/AASHTO T 259) is one of these long-term exposure tests, which ponds sodium chloride (NaCl) solution on a concrete slab for a specified time and then measures the chloride concentration with depth. Although this test provides a basic one-dimensional chloride ingress profile, it has many limitations. The first drawback is the length of the test. The entire test, from curing to conditioning to testing, takes at least four to four-and-a-half months for normal concrete. However, higher quality concrete and concrete containing pozzolans such as fly ash and silica fume have lower permeability, and thus require more exposure time for sufficient chloride ingress [49], [66], [67]. The bulk diffusion test (ASTM C1556/NT Build 443) is another long-term test for determining the penetration of chloride ions into hardened cementitious materials. The NT BUILD and ASTM procedures differ slightly, but the overall process is the same. Cylindrical specimens are sealed on all faces except one and then exposed to a NaCl solution for a minimum of 35 days; for higher quality concrete, the exposure period must be extended to at least 90 days to achieve sufficient chloride ingress [49], [67]–[69]. After the exposure period, the chloride concentration is measured with depth to determine the chloride profile and apparent chloride diffusion coefficient. Similar to the salt ponding test, the

length of the bulk diffusion test makes it impractical for design and quality control purposes; however, these test methods are often used as comparison for shorter-term test methods used to estimate chloride durability.

Corrosion test methods also simulate more realistic exposure conditions and measure the time to corrosion initiation; however, these methods require longer than 30 days and complex test setup. ASTM G109 is a corrosion test method, which attaches resistors to embedded steel in concrete prism specimens that are ponded with NaCl solution [70], [71]. The voltage is measured across the resistor, and the current is calculated as a function of time until corrosion occurs. UNE-EN ISO 9227 is a salt spray test that subjects specimens to NaCl solution inside a climatic chamber for 82 days [72]. The chamber is filled with compressed air, and the specimens are periodically removed, weighed, and returned in a different position to homogenize the exposure.

4.1.2. Sulfate Durability

Sulfate attack is another durability concern that can lead to concrete deterioration. Sulfate attack can be the result of internal or external sources of sulfate; however, external sulfate attack from environment exposure conditions is more common. Sulfates including sodium, calcium, and magnesium can naturally occur in soils or water that concrete structures are in contact with. Sulfate attack can take many forms depending on the composition of the sulfate and concrete. Damage from sulfate attack can occur due to “chemical attack on the aluminate phases in the cementing materials, due to chemical attack on the calcium-silicate matrix, due to acidic dissolution of the matrix, or due to physical attack due to sulfate salt crystallization in pores near surface subjected to drying” [73].

Sulfate test methods consist of various methods to accelerate damage and various methods to measure the damage. Methods to accelerate damage include: adding gypsum, reducing specimen size, creating an electrical potential, vacuum saturating specimens, and increasing the sulfate concentration for exposure. Based on the method selected to accelerate damage, different methods are used to measure the damage including: measuring expansion, mass loss, strength loss, or change in electrical resistivity. The acceleration method and selected degradation measure influence the conclusions drawn regarding the performance of concrete under sulfate attack. Small cement paste or mortar specimens and artificially high sulfate concentrations may accelerate damage, but are not realistic of concrete sulfate durability. Additionally, expansion and visual inspection may not be adequate measures of deterioration due to sulfate attack.

The most well-known standardized test methods for evaluating sulfate resistance are ASTM C1012 and ASTM C452 [59], [73]–[79]; however, both of these methods have many drawbacks. While these methods are meant to give an indication of concrete durability to sulfate exposure, they are limited to complete immersion of mortar bar specimens, which is not realistic of field conditions. Furthermore, these methods rely on measuring length change as an indication of sulfate resistance without considering loss of strength or material integrity. Another drawback to ASTM C1012 is that the test requires months to years before obtaining results. ASTM C452 is a shorter test; however, the sulfates are internally mixed into the specimens instead of supplied as an external solution. This greatly reduces the time for sulfate attack because the sulfates do not need to penetrate into the specimens, but this is not representative of field conditions and cannot

be used on blended cements or SCMs because it does not factor the reduced permeability into sulfate resistance. For these reasons, new methods need to be investigated that provide results in a reasonable timeframe while still being representative of typical concrete conditions.

4.2. CHLORIDE DURABILITY

4.2.1. ASTM C1202/AASHTO T 277

The ASTM C1202 - *Standard Test Method for Electrical Indication of Concrete’s Ability to Resist Chloride Ion Penetration*, or chloride ion penetration (CIP) test, is a short-term method that has been widely used for quality control and acceptance testing of concrete . This test was originally termed the rapid chloride permeability test or commonly referred to as the RCP test [51]; however, the test method is not rapid and does not measure permeability, so the acronym is misleading. ASTM C1202 and AASHTO T 277 measure the ionic movement of all ions present in the pore solution, not just chloride ions, through concrete and report the results as a resistance to the penetration of chloride ions based on the charge passed through the specimen as provided in Table 21 .

Table 21. Chloride ion penetrability classifications per ASTM C1202 / AASHTO T 277 [80], [81].

Charge Passed (coulombs)	Chloride Ion Penetrability
> 4,000	High
2,000 – 4,000	Moderate
1,000 – 2,000	Low
100 – 1,000	Very Low
< 100	Negligible

The test method records the total charge passed through a 4 in. dia. by 2 in. tall (100 mm dia. by 50 mm tall) saturated specimen subjected to 60 V DC for a period of six hours [80], [81]. At least two cylindrical specimens are required when evaluating the materials or mixture proportions “for purposes of quality control, mixture submittals, or acceptance of concrete” [80]. The specimens are typically cut from standard 4 in. by 8 in. cylinders after the prescribed curing period. ASTM C1202 provides three curing methods: moist curing for 28 days in accordance with ASTM C192, extended moist curing for 56 days in accordance with ASTM C192, and accelerated moist curing which cures specimens for 7 days in accordance with ASTM C192 followed by 21 days in lime-saturated water at $38.0 \pm 2.0^\circ\text{C}$ [80], [82]. AASHTO T 277 states to moist cure specimens for 56 days unless specified otherwise, but notes that various curing regimens have been used [81]. The extended and accelerated moist curing methods are useful for concrete mixtures containing SCMs due to the slower rate of hydration under standard curing conditions of 23°C .

The specimens are conditioned prior to the start of the test to seal the sides and saturate the concrete. The sides of the specimens are sealed using a rapid setting coating, usually a two-part epoxy, and allowed to cure according to the manufacturer’s instructions. Once cured, the specimens are placed in a desiccator, surface-dry, with the end surfaces exposed and a vacuum pressure of less than 50 mmHg is maintained for three hours. The specimens are then covered

with water that has been vigorously boiled and allowed to cool to ambient temperature. Vacuum is maintained for an additional hour after which the vacuum is removed from the desiccator while keeping the specimens submerged under water for 18 ± 2 hours. After vacuum saturation, the specimens are mounted into CIP cells as shown in Figure 20.

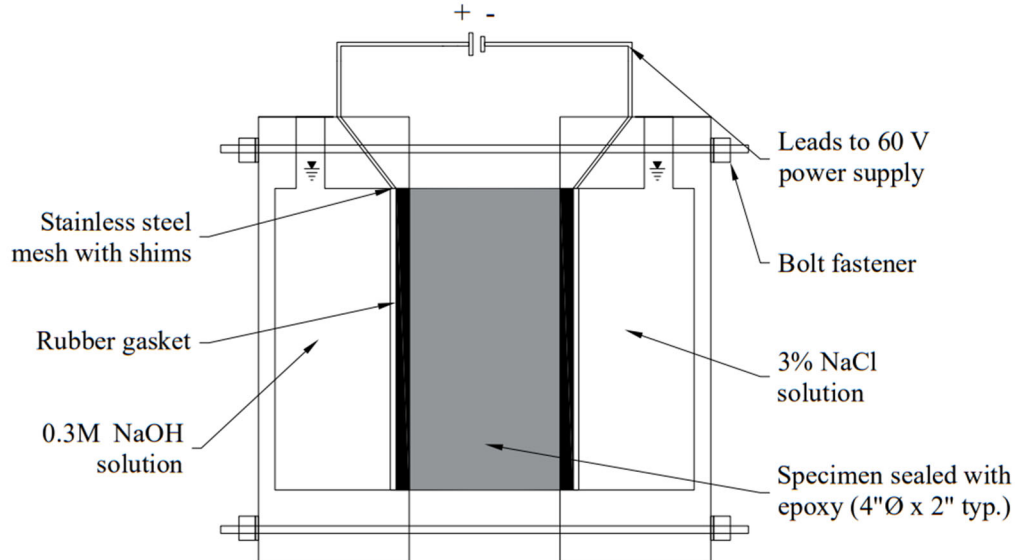

Figure 20. Diagram of ASTM C1202/ AASHTO T 277 specimen cell setup with rubber gaskets.

The specimens can be mounted to the cells using low viscosity specimen-cell sealant, high viscosity specimen-cell sealant, or a rubber gasket alternative. The applied voltage cells that the specimens are mounted to are made of “poly (methyl methacrylate)” and contain chambers to hold the testing solutions [80]. The dimensions of the cells, electrically conductive mesh, and external connectors that lead to the power supply are detailed in ASTM C1202 and AASHTO T 277 [80], [81]. Once the specimens are mounted, the chamber of the cell containing the top surface of the specimen is filled with 3.0% sodium chloride (NaCl) solution. The other cell chamber is filled with 0.3 N sodium hydroxide (NaOH) solution. The leads are connected to the power supply which is set to 60.0 ± 0.1 V and the temperature is maintained in the range of 20°C to 25°C . The current passed through the specimen is measured at least every 30 min. The test is run for 6 hr. and the total charge passed, in coulombs, is measured from the plot of current versus time. The cumulative total charge passed is then used to rate the concrete’s ability to resist chloride ion penetration according to Table 21. A summary of the approximate costs to run the ASTM C1202 / AASHTO T 277 for one set of specimens is provided in Table 22.

Table 22. Summary of required equipment and approximate costs using ASTM C1202 / AASHTO T 277¹.

Non-Consumables – Approximate Cost		Consumables – Approximate Cost		
<ul style="list-style-type: none"> • Voltage application and data readout apparatus, capable of holding 60 ± 0.1 V and displaying current to ± 1 mA – \$8,000 • Applied voltage cells, each set consists of two symmetric poly (methyl methacrylate) chambers³ – \$2,100 - \$3,600 • Electrically conductive mesh screens (included with off-the-shelf cells) – \$0 - \$500 • External connectors – \$50 • Temperature measuring device, 0°C–120°C range – \$500 • Computer for data readout – \$1,000 • Vacuum pump or aspirator – \$1,000 • Vacuum gage or manometer, accurate to ± 5 mmHg over range 0 - 100 mmHg – \$50 • Vacuum desiccator – \$200 - \$1,000 • Separatory funnel – \$100 • Tubing for vacuum saturation setup – \$50 • Boiling flask – \$50 - \$100 • Hot plate – \$200 - \$400 • Rubber gaskets (included with off-the-shelf cells)⁴ – \$0 - \$200 • Bolts, nuts, and washers for clamping cells (included with off-the-shelf cells)⁴ – \$0 - \$10 	<ul style="list-style-type: none"> • Rapid setting, electrically nonconductive coating for sealing sides² – \$50 • 3.0% NaCl reagent grade solution – \$10 • 0.3 N NaOH reagent grade solution – \$10 • Specimen-cell sealant⁴ – \$10 			
Total Approximate Cost:		\$14,250 - \$16,750		
≤ 30 Days	Concrete	≤ \$30,000	Uncomplicated	No Hazards
X	✓	✓	✓	✓

¹ The approximate costs are for testing three 4 in. dia. x 2 in. tall specimens.

² This estimate does not include associated consumables needed for mixing and applying the rapid setting, electrically nonconductive coating.

³ The applied voltage cells can be purchased or fabricated. There is also an option to have cells with cooling fins attached to the outside of the solution chambers to prevent overheating.

⁴ If the rubber gasket alternative is chosen for mounting the specimens, the gaskets and bolts would be non-consumable items and the consumable specimen-cell sealant would not be needed.

Drawbacks of the method:

One of the main criticisms of ASTM C1202 / AASHTO T 277 is that the electrical conductivity measured depends not only on the pore structure of the concrete but also on the chemistry of the pore solution. As a result, changes to the chemical makeup of the concrete, which can occur by using supplementary cementitious materials or admixtures, can alter the results [62], [66], [67], [80], [81], [83]. And while not as long as chloride exposure tests, ASTM C1202 requires moist curing of the specimens for 28 days unless SCMs are used, in which case, extended moist curing is recommended for 56 days or longer. AASHTO T277 states that all specimens should be cured for 56 days unless otherwise specified [80], [81].

Another drawback is that the high voltage applied over the specimen increases the temperature, which in turn increases the conductivity or charge passed over the specimen, leading to a higher apparent permeability [48], [49], [67], [84]. This effect is amplified in low quality concrete because the temperature rise is related to the product of the current and voltage, and the current is greater in low quality concrete [49], [84]. Consequently, low quality concrete performs worse and might not meet specifications. In addition, any conductive material present in the concrete, such as reinforcing steel or conductive fibers, will cause the results to be higher, falsely indicating a higher chloride ion penetrability [49], [80], [81]. The presence of additional ions in solution, the temperature increase due to high voltage, and the presence of conductive materials will all result in a higher measured conductivity, indicating an artificially low resistance to chloride penetration. Since this represents a worst-case result, the test can still be used for quality control [49]. The CIP test can be used to qualify a mix, but further testing should be done before disqualifying it [49], [85].

Available equipment:

For ASTM C1202/AASHTO T 277, a voltage application and data readout apparatus that meets the specifications is available for purchase from several companies as shown in Figure 21. The voltage can be set between 5 and 60 V in 5 V increments. The temperature can also be measured and recorded during testing.

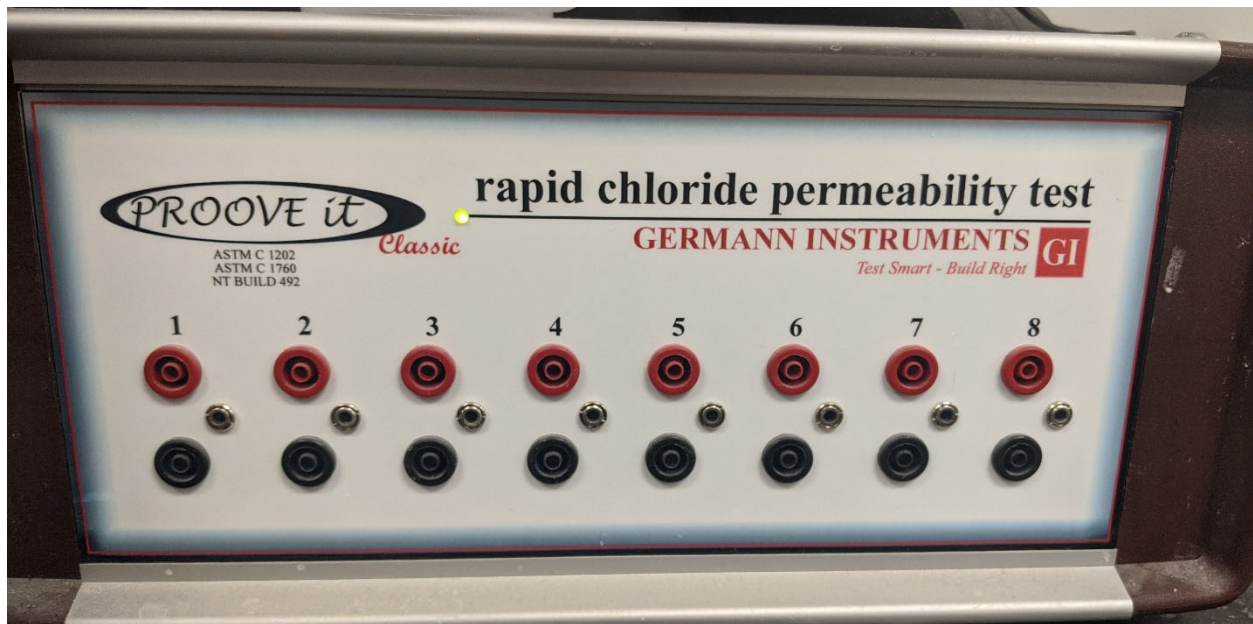

Figure 21. Picture of PROOVEit voltage application and data readout apparatus used for ASTM C1202/AASHTO T 277 and NT Build 492.

4.2.2. NT Build 492

The NT Build 492 method is similar to ASTM C1202, but measures the chloride penetration depth instead of the total charge passed [86]. The test method uses three 4 in. dia. x 2 in. tall (100 mm dia. x 50 mm tall) specimens and applies an external electrical potential across the specimens. The test method does not specify a curing time, but does have a vacuum saturation preconditioning procedure. Once cut, the surface-dry specimens are placed into a vacuum desiccator with the end surfaces exposed. The absolute pressure is reduced to 7.5 – 37.5 mmHg and maintained for three hours. The specimens are then covered with saturated calcium hydroxide ($\text{Ca}(\text{OH})_2$) solution while still under vacuum for an additional hour. Air is then allowed to re-enter the desiccator and the specimens are kept submerged in saturated $\text{Ca}(\text{OH})_2$ solution for 18 ± 2 hours.

Once conditioned, a rubber sleeve is fitted around the specimen and secured with two stainless steel clamps. The catholyte reservoir (plastic container) is filled with approximately 12 L of 10% NaCl solution (catholyte). The specimen is then placed on a plastic support in the catholyte reservoir and the inside of the sleeve is filled with 300 mL of 0.3 M NaOH solution (anolyte) as shown in Figure 22. The anode is immersed in the anolyte solution and the leads are connected to the power supply.

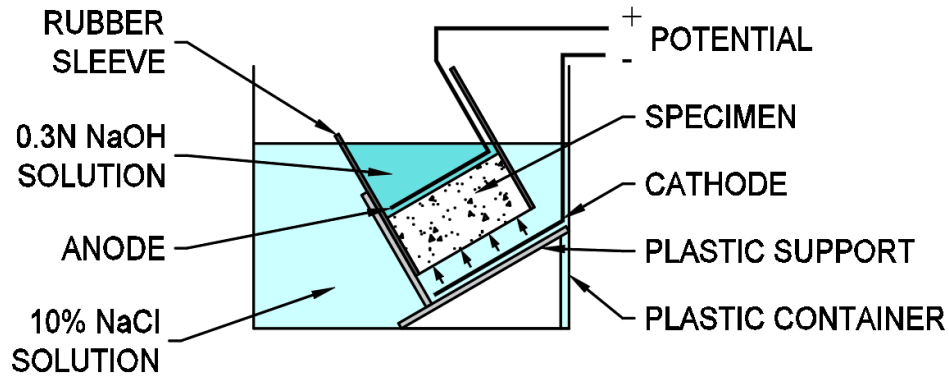

Figure 22. Diagram of NT Build 492 test setup [86].

The voltage is initially set to 30 V and the initial current is recorded. The voltage is adjusted if necessary based on the initial current, and the test duration is chosen (typically 24 hours) from a table provided in NT Build 492 [86]. The temperature is also recorded and must be maintained between 20°C–25°C. After the test duration is complete, the specimen is removed from the sleeve and split in half axially. The freshly exposed face is sprayed with a 0.1 M silver nitrate solution, which reacts with chloride ions to form silver chloride precipitate and display the chloride penetration depth. The depth of chloride penetration from the surface is measured using a slide caliper at 10 mm intervals across the split face to obtain seven depths. The depth is measured to an accuracy of 0.1 mm. The testing parameters and results are used to calculate the non-steady-state migration coefficient. NT Build 492 measurements are less affected by conductive ions in concrete than ASTM C1202 (AASHTO T 277), so the test method is applicable to a wider range of concrete mixtures [67]. As a result, the NT Build 492 test method may be more appropriate for testing concrete mixtures using alternative SCMs, which could alter the pore solution conductivity. A summary of the approximate costs to run NT Build 492 for one set of specimens is provided in Table 23.

Table 23. Summary of required equipment and approximate costs using NT Build 492.

Non-Consumables – Approximate Cost		Consumables – Approximate Cost		
<ul style="list-style-type: none"> • Voltage application and data readout apparatus, capable of holding 60 ± 0.1 V and displaying current to ± 1 mA – \$8,000 • Silicone rubber sleeves, ID/OD 100/115 mm and 150 mm long – \$100 • Stainless steel clamps, diameter range 105 – 115 mm and 20 mm wide – \$30 • Catholyte reservoirs, plastic containers – \$10 • Plastic supports¹ – \$100 • Cathode stainless steel plate – \$100 • Anode stainless steel mesh or plate with holes – \$100 • Thermometer or thermocouple with readout device capable of reading to $\pm 1^\circ\text{C}$ – \$500 • Computer for data readout – \$1,000 • Vacuum pump capable of maintaining pressure of less than 37.5 mmHg – \$1,000 • Vacuum desiccator – \$200 - \$1,000 • Separatory funnel or container for adding $\text{Ca}(\text{OH})_2$ – \$100 • Tubing for vacuum saturation setup – \$50 • Caliper with precision of ± 0.1 mm – \$100 	<ul style="list-style-type: none"> • $\text{Ca}(\text{OH})_2$, technical quality – \$10 • NaCl, chemical quality – \$10 • NaOH, chemical quality – \$10 • AgNO_3, chemical quality – \$10 	<hr/> Total Approximate Cost: \$11,500 - \$12,250		
≤ 30 Days	Concrete	$\leq \$30,000$	Uncomplicated	No Hazards
X	✓	✓	✓	X

¹ The plastic supports will need to be fabricated per the design specifications in NT Build 492.

Drawbacks of the method:

Although NT Build 492 does not specify a curing regimen, the same constraints as ASTM C1202 apply; for concrete using SCMs, extended moist curing for at least 56 days is recommended to allow time for the pozzolanic reaction to take place. Another drawback to this method is the use of hazardous materials and thus hazardous waste disposal. The costs of waste disposal were not included in the estimate, but would need to be considered for the silver nitrate and chemical solutions.

4.2.3. AASHTO T 358

The AASHTO T 358 - *Standard Method of Test for Surface Resistivity Indication of Concrete's Ability to Resist Chloride Ion Penetration*, is another electrical method for determining chloride durability of concrete [87]. Resistivity is an indirect method of assessing the ease with which chloride ions are able to penetrate concrete [49]. The resistivity of concrete is primarily measured by the conductivity of its pore solution [49], [67]. For the surface resistivity (SR) test, a small alternating current (AC) is applied to the concrete specimen by means of a four-point Wenner probe array [87] as shown in Figure 23. The current is applied through the outer pins and the resulting potential (voltage) across the inner pins is measured instantaneously. The resistivity of the concrete can then be calculated using the applied current, measured voltage, and dimensions of the cylinder.

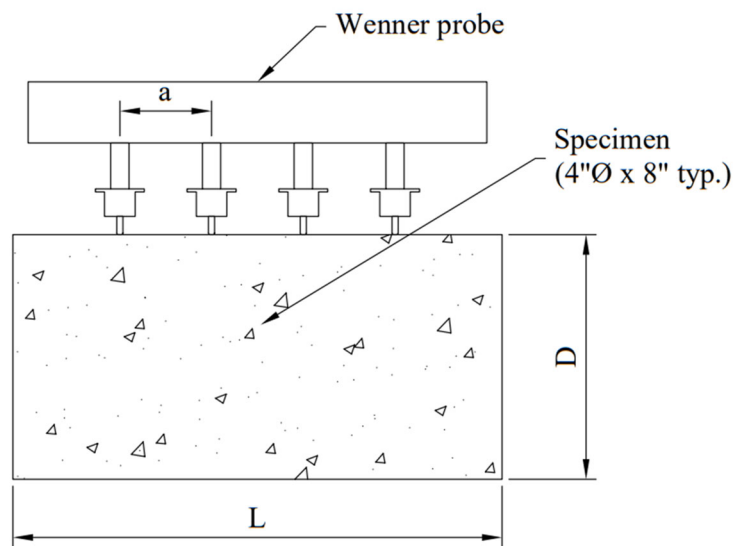

Figure 23. Diagram of four-point Wenner probe for surface resistivity test setup.

The standard states a minimum of three cylinder specimens to be used for testing. The cylinders should be marked into quadrants at 0° , 90° , 180° , and 270° . Following mold removal and immediately placed in the moist room or curing container. The specimens should be moist-cured for 28 days prior to testing unless specified otherwise. The method recommends moist-curing in a 100% relative humidity moist room, but other methods are acceptable. There is also a note for accelerated moist-curing, which provides 7 days of moist-curing followed by 21 days in lime-saturated water at $38.0 \pm 2.0^\circ\text{C}$, similar to ASTM C1202.

Once cured, the specimens must be tested within five minutes of removing from the moist room or curing container to prevent the specimen from drying. The first cylinder is placed on the specimen holder, and the surface is cleaned with a saturated sponge or towel to have a saturated surface wet condition. The Wenner probe is then placed on the longitudinal side of the specimen at quadrant 0° , making sure the probe is centered between the faces of the specimen, and the first measurement is taken. The specimen is rotated until every quadrant is measured twice, resulting in eight resistivity measurements. This is done for each specimen, taking care to ensure the

specimens stay saturated during measurement. Specimen drying will result in higher resistivity values and increase the variability, creating erroneous results. The testing temperature must be maintained between 20°C and 25°C.

The average resistivity of each cylinder is calculated and the percent relative standard deviation (%RSD) is checked to ensure it is less than 7.5%. After checking the %RSD and repeating the test if necessary, the average resistivity is taken for the set of cylinders. If the specimens were cured in saturated limewater, the average is multiplied by 1.1. The chloride ion penetrability resistance is based on the final average value and the ranges presented in Table 24.

Table 24. AASHTO T 358 chloride ion penetrability classifications based on surface resistivity values for 4 in. x 8 in. and 6 in. x 12 in. cylinders [87].

Chloride Ion Penetrability	4 in. x 8 in. cylinder (kΩ-cm)	6 in. x 12 in. cylinder (kΩ-cm)
High	< 12	< 9.5
Moderate	12 – 21	9.5 – 16.5
Low	21 – 37	16.5 – 29
Very Low	37 – 254	29 – 199
Negligible	> 254	> 199

The non-destructive nature, speed, and ease of use of this technique make the surface resistivity test method attractive when compared to tests like CIP, bulk diffusion, and salt ponding [49], [62], [67], [88]. Chini et al. (2003) correlated the results of surface resistivity and CIP from more than 500 concrete sample sets [62]. The samples were taken from concrete pours at job sites across the state of Florida and encompassed a wide range of mix designs. A strong relationship between the CIP and SR tests was found; the R² value for the samples tested at 28 days was reported as 0.95. A summary of the approximate costs to run AASHTO T 358 for one set of specimens is provided in Table 25.

Table 25. Summary of required equipment and approximate costs using AASHTO T 358.

Non-Consumables – Approximate Cost		Consumables – Approximate Cost		
<ul style="list-style-type: none"> • Surface resistivity apparatus – \$3,500 • Specimen holder – \$50 				
Total Approximate Cost: \$3,500				
≤ 30 Days	Concrete	≤ \$30,000	Uncomplicated	No Hazards
X	✓	✓	✓	✓

Drawbacks of the method:

The main drawback to using surface resistivity to measure chloride durability is establishing an accelerated curing method to more accurately represent mature concrete containing SCMs. The accelerated moist-curing procedure detailed in the method may not provide the same results as standard moist-curing, thus it is recommended to create a correlation between the extended

moist-curing and accelerated moist-curing. AASHTO T 358 also lists a number of interferences with the measurement including concrete containing certain admixtures, reinforcing steel, and other conductive materials. Additionally, the spacing of the four probe points, specimen geometry, curing, degree of water saturation, and temperature can significantly affect the measured electrical resistivity of concrete [49], [50], [62], [67], [87], [89]. Other factors known to influence the resistivity include: water-cement ratio, supplementary cementitious materials, aggregate type, and degree of consolidation [87]. To account for some of the variables, AASHTO T 358 specifies 4 in. or 6 in. diameter cylinder specimens, a testing temperature of 20 to 25°C, and saturated, surface wet conditions during testing. Correction factors have also been researched and developed for geometry effects, degree of saturation, accelerated curing, and testing temperature to increase the accuracy of surface resistivity measurements [89]–[91].

4.2.4. AASHTO TP 119

Another electrical standard, AASHTO TP 119 - *Standard Method of Test for Electrical Resistivity of a Concrete Cylinder Tested in a Uniaxial Resistance Test*, measures the electrical resistance of concrete across the ends of a concrete cylinder to measure a bulk resistivity (BR) instead of a surface resistivity [92]–[95]. This is done by placing a concrete cylinder between two stainless steel plate electrodes from which current is passed through the specimen and the resistance across the specimen is measured as shown in Figure 24 [91], [92]. To ensure good electrical contact between the specimen and electrodes, a conductive medium such as a saturated sponge can be used; however, the surface finish of the ends should still be flat [90], [92], [93].

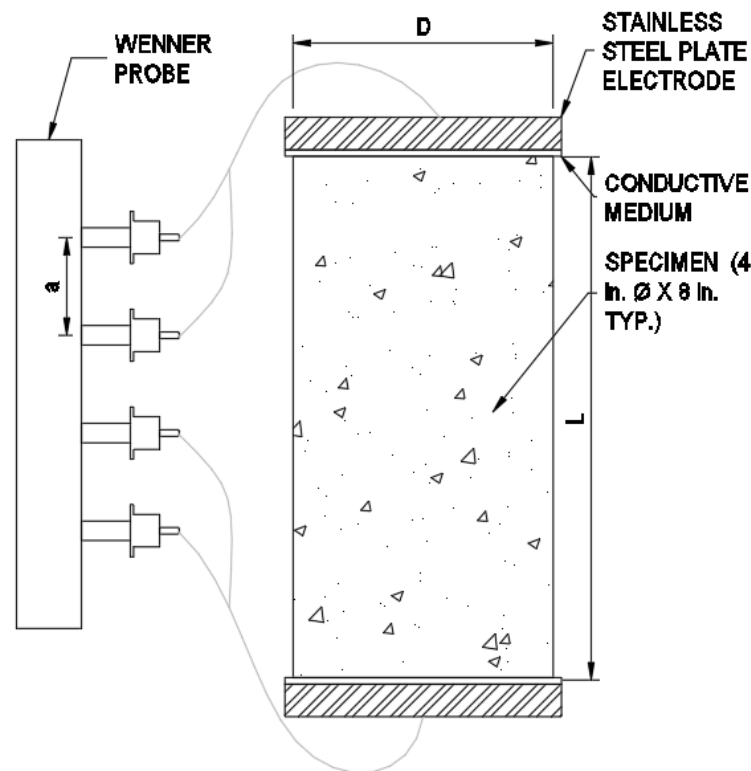

Figure 24. Diagram of bulk resistivity test setup.

The standard states a minimum of three cylinder specimens to be used for testing, and the specimens should be moist-cured for 28 days prior to testing unless specified otherwise. The conditioning procedure states to immerse the specimens in saturated limewater with the volume of solution being two to three times the volume of the specimens. The curing temperature should be maintained at $23 \pm 2^\circ\text{C}$. However, the method does state that alternative curing regimes are allowed if approved by the sponsoring agency. AASHTO T 358 and AASHTO TP 119 are in the process of being updated to include conditioning options, which should make the suggested curing methods consistent.

During testing, the temperature should be maintained at $23^\circ\text{C} \pm 2^\circ\text{C}$, and the testing should be performed on a non-conductive surface (e.g., a rubber or plastic mat). A resistivity meter or surface resistivity apparatus (from AASHTO T 358) can be used to connect to the electrode plates. Before measuring the test specimen, the resistance through the top and bottom conductive electrode plates and conductive media, without the specimen, is measured. The conductive media can be sponges, cloths, gel, or other medium that provides uniform contact across the faces of the specimens. Since the resistance of the media is dependent on the moisture content, the weight of the electrodes and specimen must be factored into the resistance measurement. Once the conductive mediums are measured, the first specimen is removed from the curing container, the excess water is blotted off using a damp towel or cloth, and the specimen is placed between the two conductive mediums and electrodes to measure the resistance. The temperature of the test specimen is then measured using an infrared thermometer, and the specimen is placed back in the curing container. The specimen should be tested as quickly as possible (within a few minutes) to prevent specimen drying.

The combined resistance of the conductive media is subtracted from the measured resistance of each specimen, and corrections are made for the specimen geometry and probe tip spacing if a surface resistivity apparatus is used. After applying the correction factors, the average resistivity of the set is calculated and the chloride ion penetrability resistance is determined from the ranges presented in Table 26. A summary of the approximate costs to run AASHTO TP 119 for one set of specimens is provided in Table 27.

Table 26. AASHTO TP 119 chloride ion penetrability based on uniaxial (bulk) resistivity values [95].

Chloride Ion Penetrability	Uniaxial Resistivity (k Ω -cm)
High	< 5.2
Moderate	5.2 – 10.4
Low	10.4 – 20.8
Very Low	20.8 – 207
Negligible	> 207

Table 27. Summary of required equipment and approximate costs using AASHTO TP 119.

Non-Consumables – Approximate Cost		Consumables – Approximate Cost		
• Resistivity apparatus – \$3,500		• Conductive medium – \$5		
• Stainless steel plate electrodes – \$100				
• Connector cables – \$10				
• Conductive medium – \$5				
• Infrared thermometer – \$150				
Total Approximate Cost ¹ : \$3,750				
≤ 30 Days	Concrete	≤ \$30,000	Uncomplicated	No Hazards
X	✓	✓	✓	✓

¹ If the resistivity apparatus is purchased for AASHTO T 358 and TP 119, this cost item would be \$0 and the total additional cost to perform bulk resistivity in tandem with surface resistivity would be approximately \$250.

Drawbacks of the method:

The main drawbacks for AASHTO TP 119 are the same as those for AASHTO T 358; an accelerated curing method is needed to more accurately represent mature concrete within 30 days, and pore solution conductivity needs to be accounted for to get a measurement of pore structure itself.

Additional influencing factors that should be considered with any electrical resistivity test include chemical admixture composition, specimen geometry, temperature, and conditioning, especially with respect to the degree of saturation of the specimen [91], [92]. An advantage of the bulk resistivity test over the surface resistivity test is that the resistance of the entire specimen is measured and the operator does not have to be concerned over placement of the probe tips. Studies have shown good linear correlation between bulk and surface resistivity measurements for differing concrete mix designs and specimen ages [91], [92], [96]. First principles using Ohm’s law relate the total charge passed from CIP to the bulk resistivity of the material as given in Eq. 1 [17,28,33,34]. The final numerator of Eq. 1 assumes the standard testing voltage of 60 V, a testing period of six hours, and a specimen geometry of 4 in. diameter x 2 in. tall.

$$Q = \int_{0 \text{ hr}}^{6 \text{ hr}} I dt = \int_{0 \text{ hr}}^{6 \text{ hr}} \frac{V A}{\rho L} dt = V \frac{A}{L} t \frac{1}{\rho} = \frac{21,180}{\rho} \quad (1)$$

Where Q = total charge passed from CIP (coulombs)

V = test voltage (V)

L = thickness of the specimen (cm)

A = cross-sectional area of the specimen (cm²)

t = test period (s)

ρ = bulk resistivity (kΩ-cm)

Available equipment:

For AASHTO TP 119, there are a few options. The Resipod shown in Figure 25 can be used with connector cables for the stainless steel electrode plates. Alternatively, there are two options that are designed solely for measuring bulk resistivity provided by Giatec (called an RCON) and Germann Instruments (called a Merlin).

4.2.5. Chloride Binding

For chloride durability of concrete, it is important to consider chloride binding of the cement matrix. Chloride ions in a cementitious matrix are generally broken into two categories: water-soluble (or available) chlorides, and acid-soluble (or total) chlorides. The difference between the total and available (or free) chlorides are the “bound” chlorides. Chloride ions may be bound by the hydration products of cement or SCMs within inaccessible phases, thus limiting the chance for damage [59], [97]. Chloride ions react chemically with tricalcium aluminate or its hydrates to form Friedel’s salt, which prevents the chlorides from penetrating further into the concrete and causing corrosion of reinforcing steel.

The chloride binding capacity of the system is directly influenced by the chemical composition of the cement and w/cm of the mixture [98]. Literature shows that SCMs impact the chloride ion penetrability of concrete not only by reducing pore size but also by binding the chloride ions to limit ingress [48], [97], [99]–[101]. SCMs with high quantities of alumina, such as metakaolin and some fly ashes, have increased chloride binding capacity [97], [101]–[103]. AASHTO PP 84 notes that additional testing should be added in the future to account for chloride binding [98].

4.2.6. Existing Available Equipment

For AASHTO T 358 and TP 119, Proceq makes a surface resistivity apparatus called Resipod as shown in Figure 25. Resipod comes in two models: a 38 mm probe spacing and 50 mm probe spacing. The resistance can be measured from 1 to 1,000 k Ω -cm, and the current can be supplied at a variable 10 to 50 μ A or 200 μ A.



Figure 25. Picture of Resipod surface resistivity apparatus by Proceq for AASHTO T 358.

Other companies, such as Giatec, make other versions of surface resistivity meters. However, these meters that encompass the concrete specimens are less adaptable to different sizes of specimens, in addition, using these types of meters for bulk resistivity and formation factor determination may be more difficult.

4.3. SULFATE DURABILITY

4.3.1. USBR 4908

The United States Bureau of Reclamation (USBR) has a standard test method for measuring the sulfate resistance of concrete specimens. The test method, USBR 4908 – *Procedure for Length Change of Hardened Concrete Exposed to Alkali Sulfate*, exposes concrete specimens to sodium sulfate solutions and measures the expansion over time [104]. The method also states that magnesium sulfate solutions or a combination of sodium and magnesium sulfate can be used for the exposure solution [104].

The test specimens are 3 in. dia. x 6 in. tall cylinders cast in molds with gauge stud inserts on the top and bottom faces as shown in Figure 26. Additionally, the method specifies to place corrosion resistant metal identification tags in the bottom of the molds so that they become embedded in the concrete cylinders. The molds are filled in two layers and consolidated using an internal vibrator. After the concrete is placed in the molds, the molds are stored in a moist environment at 73°F (22.8°C) for 24 hours. The specimens are then removed from the molds and cured for 13 days at 73.4°F ± 3°F (23.0 ± 1.7°C) and 100% relative humidity or immersed in a saturated limewater tank at 73.4°F ± 3°F. At an age of 14 days, the specimens are removed from the 100% relative humidity and cured an additional 14 days at 73.4°F ± 3°F and 50 ± 2% relative humidity [104].

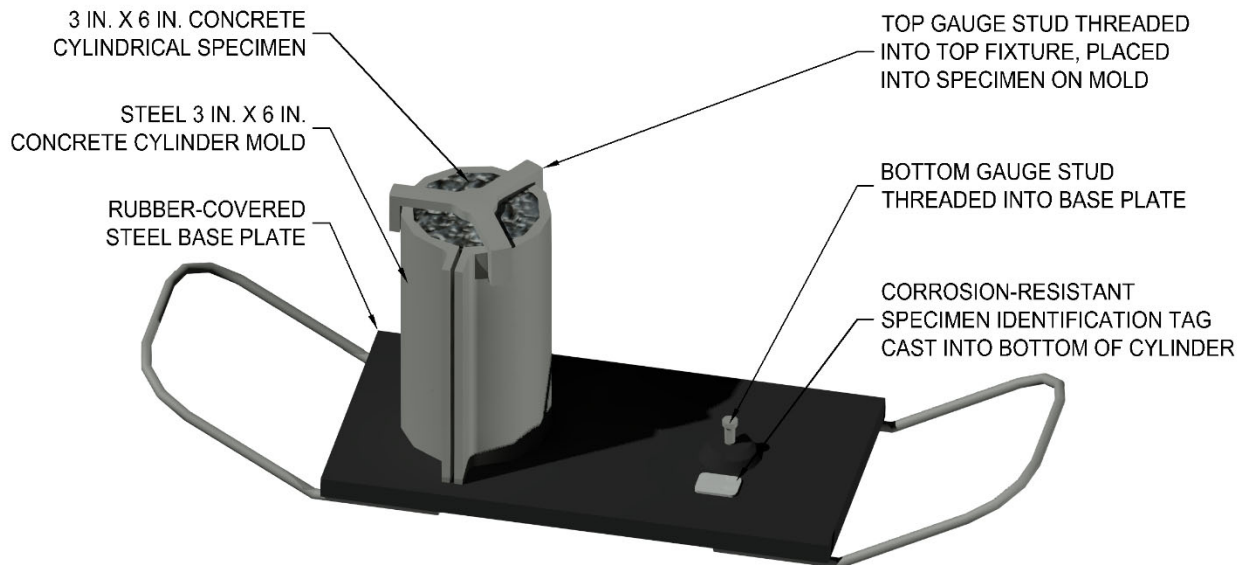

Figure 26. Diagram of typical casting mold used for USBR 4908 specimens.

After the 28 days of curing, the length of the specimens is measured to the nearest 0.001 in. (0.025 mm) using a comparator. Each time before length measurement, the gauge studs of the specimen are wiped and the hole in the base anvil of the comparator is cleaned to ensure accurate measurement. The specimens should be placed in the comparator the same direction each time. The comparator should be checked with a standard reference bar before and after taking readings and at regular intervals during readings. The specimens are placed in solution tanks after the initial reading for 24 hours before being measured again. The difference between the first two measurements is to determine expansion due to absorption. The second measurement is used for determining expansion due to sulfate attack. The specimens are placed back in the solution tanks until the next measurement. Length measurements are done after 30 days and then every three months thereafter unless more frequent measurement is required due to poor sulfate resistance.

There are three methods for exposure outlined in USBR 4908. Method A involves continuous soaking in a 2.1% sodium sulfate solution at room temperature. Method B also consists of continuous soaking of test specimens but in a 10% sodium sulfate solution at room temperature; the higher concentration of the exposure solution will produce failure in approximately one-sixth the time required for Method A. Method C accelerates failure similar to Method B by exposing the specimens to a wet-dry cycle. The test specimens for Method C are soaked for 16 hours in a 2.1% sodium sulfate solution at room temperature and then dried for 8 hours in air under a forced draft at approximately 130°F (54°C). The concentration of the solution for Methods A and C shall be maintained between 2.0 and 2.2% with periodic checks, and the solution shall be replaced entirely on a yearly basis. For Method B, the concentration shall be maintained between 9.8 and 10.2% and replaced yearly. An expansion of 0.5% is considered failure. A summary of the approximate costs to run USBR 4908 for one set of specimens is provided in Table 18.

Table 28. Summary of required equipment and approximate costs using USBR 4908.

Non-Consumables – Approximate Cost		Consumables – Approximate Cost		
<ul style="list-style-type: none"> • Comparator conforming to ASTM C490 – \$1,200 • Specimen molds¹ – \$2,000 • Solution tank for Method A or C² – \$1,300 • Automated solution tank and drying storage cabinet for Method B (with pump and heater/blower)² – \$5,000 		<ul style="list-style-type: none"> • Sodium sulfate solution – \$10 • Gauge stud inserts – \$10 		
Total Approximate Cost:		\$4,500 - \$8,250		
≤ 30 Days	Concrete	≤ \$30,000	Uncomplicated	No Hazards
X	✓	✓	✓	✓

¹ The specimen molds would need to be fabricated based on the specifications in the method.

² For Method A and C, a tank of stainless steel or other corrosion-resistant material is required for continuous immersion of test specimens. If Method B is selected, a tank for soaking and an insulated storage cabinet for drying are required to conduct the wet-dry cycles. This system can be automated with time-controlled equipment for pumping the solution and a heater and blower for circulating warm air to dry the specimens.

Drawbacks of the Method:

The largest drawback to USBR 4908 is the length required for testing; the test method typically requires a minimum of 1 to 2 years before results give an indication of concrete performance for sulfate resistance. Additionally, if the soaking and drying procedure outlined for Method C is chosen, the cost for automated setup for acceptance testing would exceed \$30,000.

4.3.2. MNS Test

One method for evaluating sulfate durability of concrete first introduced by Mulenga et al., 1999 [105], and later described in detail in a doctoral dissertation [106], is the so called MNS (Mulenga-Nobst-Stark) method named after the authors of the first conference paper. This method is relatively new and has only seen adoption within Germany.

In this method, concrete prisms (40 mm x 40 mm x 160 mm or 1.6 in. x 1.6 in. x 6.3 in.) are cast and cured in for 28 days at 20°C (68°F) after which point they are immediately exposed to a sodium sulfate solution containing 33.9 g SO₄²⁻/L at 150 mbar of vacuum (4.45 inches of mercury) [107]. The soaked specimens are then stored at 8°C (46.4°F) for a duration of either 84 or 120 additional days. These specimens along with companion specimens (not exposed to the sulfate solution) that are stored in water are then tested in uniaxial tension. If tested at 84 days of exposure, the sulfate-exposed specimens must reach a normalized tensile strength (compared to control) of at least 80% to pass this test. If the specimens are stored for 120 days, the specimens must reach a normalized strength of 70% of control to pass. A summary of the approximate costs associated with this method is provided in Table 29.

Table 29. Summary of required equipment and approximate costs using the MNS test.

Non-Consumables – Approximate Cost		Consumables – Approximate Cost		
<ul style="list-style-type: none"> Prism molds – \$1,080 (two – 3-gang molds; Humboldt Mfg Model H-3270) Direct tension machine¹ – \$7,000 (similar to Mark-10 ESM1500LC) Grips for 40 mm specimens – \$3,000 – \$5,000 Refrigerator – \$1,500 (similar to Marvel Scientific MS24RAG4RW) 		<ul style="list-style-type: none"> Sodium sulfate, anhydrous powder – \$15 Storage containers – \$15 		
Total Approximate Cost:		\$12,750 - \$14,750		
≤ 30 Days	Concrete	≤ \$30,000	Uncomplicated	No Hazards
X	²	✓	✓	✓

¹ While it is presumed that a concrete lab will have generally testing equipment such as a cylinder grinder, mixer, and compression machine, it is not anticipated that a direct tension machine will be standard equipment.

² This method is purported to be performed on concrete, however the small specimen cross-section would limit the nominal maximum aggregate size to approximately 0.5 in. Increasing the specimen size would necessitate larger molds, storage containers, refrigerators, tension machines (with larger capacities) and considerably larger grips. All of which would immediately make this method cost more than \$30,000.

Drawbacks of the Method:

There are several drawbacks to the MNS method; firstly the time and temperature in which the specimens are exposed is 28 days at 20°C. This would expose specimens with supplementary cementitious materials well before maturation and pozzolanic reactivity has had time to have significant effect. Following this, the method is then carried out for an additional 3-4 months of time. Lastly, the specimen size is not conducive to the majority of concretes due to the restrictive size that would need to be placed on the aggregate gradation.

4.3.3. Soaking and Drying Test

One method of exacerbating deterioration of concrete due to sulfate exposure is repeated wetting and drying cycles; one such test method was developed by de Almeida, 1991 [108]. The repeated cycling causes sulfate ingress during soaking then crystallization upon drying; this crystallization results in internal pressure causing swelling and cracking; which aides in deeper sulfate ingress on the next soaking cycle.

For this method, 6 in. concrete cubes are cast and cured by submersion in water at 20°C for 28 days; then eight 2 in. cubes are saw cut from a cube. Four 2 in. cube specimens are then submerged in a solution of 0.434 N solution of $\text{Na}_2\text{SO}_4 \cdot 10\text{H}_2\text{O}$ (140 g $\text{Na}_2\text{SO}_4 \cdot 10\text{H}_2\text{O}$ and 860 g of water) at 20°C from two hours. The remaining four cube specimens are stored in air for the remainder of the test. Additionally, compressive strength is performed on 6 in. cubes at 28 days. The specimens that were placed in sulfate solution are removed and are then placed into a drying oven at 105°C for a minimum of 16 hours (until constant mass is achieved); after constant mass is achieved, the specimens are then cooled to room temperature. This cycle is repeated 120 times; with specimen masses recorded, photographs taken, and soak solution replaced every 15 cycles. At the end of the 120 cycles, three of the cubes are broken in compression according to ASTM C109. The companion 2 in. cube specimens not submerged for the duration of testing are also tested in compression. The change in compressive strength from the air-dried specimen to the sulfate-exposed specimen is termed the “residual strength”; this change may be an increase or decrease from the control specimen. It is theorized that increases in strength capacity are due to pore filling rather than degradation. As this method cycles through room temperature and higher, pozzolanic activity of mixes with SCMs can continue to hydrate more than control specimens that are left in air after 28 days. A summary of the approximate costs associated with performing this method is shown in Table 30.

Table 30. Summary of required equipment and approximate costs using the soaking and drying test (four – 2-in. cubes soaked, four 2-in. cubes not soaked, three – 6-in. cubes compression).

Non-Consumables – Approximate Cost		Consumables – Approximate Cost		
<ul style="list-style-type: none"> • Six inch cube molds – \$600 (four – similar to Humboldt Mfg Model H-2827) • Concrete saw – \$4,700 (similar to Humboldt Mfg Model HC-2931.2F) • Platen for 6 in. cube specimens – \$1,600 (similar to Humboldt Mfg Model HCM-0113) • Drying oven – \$1,100 (similar to Humboldt Mfg Model H-30105E) • Soaking containers – \$40 • Bench scale – \$350 (similar to Humboldt Mfg Model HB-4636A.4F) 		<ul style="list-style-type: none"> • Sodium sulfate, anhydrous powder – \$10 		
Total Approximate Cost:		\$8,400		
≤ 30 Days	Concrete	≤ \$30,000	Uncomplicated	No Hazards
X	✓	✓	✓	✓

Drawbacks of the Method:

There are several drawbacks to the soaking and drying method proposed by de Almeida; firstly the specimens are exposed after 28 days of room temperature curing which will not allow pozzolanic materials to reach adequate maturity. The testing then requires 120 cycles which take a minimum of 18 hours (more likely 24 hours); adjusting for a typical work week this would take 28 weeks before final evaluation was complete. Once completed, the testing provides no information regarding interpretation of results, and the results are based on 2 in. cubes of concrete which cannot be used to accurately determine the strength of concrete mixes using #57 stone. Lastly, the results presented by de Almeida (shown in Figure 27) are most strong related to w/cm compared to any other factor (chemistry, initial 28-day strength, control air-dried strength, 28-day porosity, \bar{S}/A , or the other factors tested); with a stark decrease in residual compressive strength as the w/cm is increased beyond approximately 0.37. There is also issues with the methodology employed in that the concrete mixes had varying amounts of binder content, SCM type (and replacement), w/cm, and water demand/slump which resulted in inconsistent results. The majority of the mixes tested gained strength after exposure regardless of SCM type, replacement level, and there was no strong relation to chemistry.

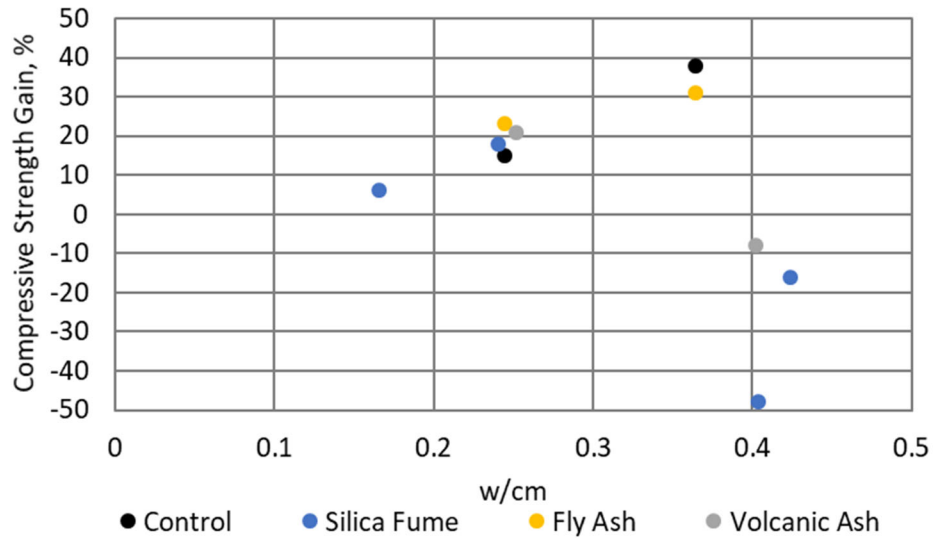

Figure 27. Comparison of w/cm to residual compressive strength, data from [108]. Control mixes have no SCM.

4.3.4. Rapid Sulfate Electrochemical Test

The rapid sulfate electrochemical test developed by Tumidajski and Turc (1995) was adapted from ASTM C1202 to measure sulfate ingress by replacing one of the solutions with sodium sulfate [109]. The results were correlated with sulfate penetration depth from two year ponding experiments and indicated the test could be useful for predicting sulfate penetration into concrete.

The test specimens were 2 in. thick slices taken from the middle of 4 in. x 8 in. cylinders. The specimens were conditioned according to the procedure outlined in ASTM C1202 [80]. Once conditioned, the specimens were assembled into the acrylic cells. The anolyte and catholyte solutions used for the cell chambers were 88 g/L Na₂SO₄ and 12 g/L NaOH, respectively [109]. The solutions were replaced hourly, and the test was conducted for six hours using 60 V. The resulting current was measured and the total charge passed (coulombs) was calculated similar to ASTM C1202.

Table 31. Summary of required equipment and approximate costs using the rapid sulfate electrochemical test.

Non-Consumables – Approximate Cost		Consumables – Approximate Cost		
<ul style="list-style-type: none"> • Voltage application and data readout apparatus, capable of holding 60 ± 0.1 V and displaying current to ± 1 mA – \$8,000 • Applied voltage cells, each set consists of two symmetric poly (methyl methacrylate) chambers³ – \$2,100 - \$3,600 • Electrically conductive mesh screens (included with off-the-shelf cells) – \$0 - \$500 • External connectors – \$50 • Temperature measuring device, 0°C–120°C range – \$500 • Computer for data readout – \$1,000 • Vacuum pump or aspirator – \$1,000 • Vacuum gage or manometer, accurate to ± 5 mmHg over range 0 – 100 mmHg – \$50 • Vacuum desiccator – \$200 - \$1,000 • Separatory funnel – \$100 • Tubing for vacuum saturation setup – \$50 • Boiling flask – \$50 - \$100 • Hot plate – \$200 - \$400 • Rubber gaskets (included with off-the-shelf cells)⁴ – \$0 - \$200 • Bolts, nuts, and washers for clamping cells (included with off-the-shelf cells)⁴ – \$0 - \$10 	<ul style="list-style-type: none"> • Rapid setting, electrically nonconductive coating for sealing sides² – \$50 • Na₂SO₄ solution – \$10 • NaOH solution – \$10 • Specimen-cell sealant⁴ – \$10 			
Total Approximate Cost:		\$14,250 - \$16,750		
≤ 30 Days	Concrete	≤ \$30,000	Uncomplicated	No Hazards
X	✓	✓	✓	✓

¹ The approximate costs are for testing three 4 in. dia. X 2 in. tall specimens.

² This estimate does not include associated consumables needed for mixing and applying the rapid setting, electrically nonconductive coating.

³ The applied voltage cells can be purchased or fabricated. There is also an option to have cells with cooling fins attached to the outside of the solution chambers to prevent overheating.

⁴ If the rubber gasket alternative is chosen for mounting the specimens, the gaskets and bolts would be non-consumable items and the consumable specimen-cell sealant would not be needed.

Drawbacks of the Method:

The drawbacks to the sulfate electrochemical test are the same as those for ASTM C1202. Although the test only takes six hours, the curing required to achieve mature concrete for durability performance when using SCMs exceeds the 30 day criteria. Additionally, the same interferences of conductive material and changes in pore solution chemistry would affect the results.

4.3.5. Partial Immersion

Since there is currently no standardized test method for evaluating concrete specimens for sulfate resistance, several researchers have developed their own methods [76]–[78]. Although the type of sulfate solution, concentration of solution, degradation measure, and specimen size may vary, the objective is the same, to measure sulfate resistance of concrete. The partial immersion of concrete specimens in sulfate solution provides a more representative exposure condition to that encountered in the field. The exposure to the atmosphere creates an evaporation front, which draws sulfate solution into the concrete via capillary suction. This sulfate ingress occurs more rapidly than pure diffusion (from completely immersed specimens), thus resulting in faster and more severe deterioration [78].

A study by Hartell et al. 2010 conducted a partial immersion test on 4 in. by 8 in. concrete cylinders in a 5% sodium sulfate solution [78]. Three concrete mixtures using portland cement were made with w/cm of 0.40, 0.55, and 0.70 to represent high-quality, typical, and poor quality concrete, respectively. The concrete cylinders were cast and cured for 24 hours in the molds. After demolding, the test specimens were immediately placed in the exposure solution. The short curing period was chosen to characterize true field conditions and construction methods, which do not allow for 28-day curing. The specimens were submerged halfway up the length of the cylinder in 5% sodium sulfate solution and stored in the lab under ambient conditions. Control specimens were submerged in limewater following the same conditions. Hartell et al. assessed sulfate resistance of the concrete specimens by conducting a visual inspection, measuring expansion, and testing for compressive and splitting tensile strength.

The specimens were exposed to the sodium sulfate solution for a period of two years. The visual inspection of the specimens showed increasing surface disintegration and cracking from the 0.40 to 0.55 to 0.70 w/cm [78]. The majority of deterioration was observed in the half of the specimen exposed to the atmosphere (not submerged in the solution). Expansion measurements were taken by measuring the diameter at regular intervals along the length of the cylindrical specimens. The expansion was relatively similar for the mixtures with an approximate increase in diameter of 1.13%, 1.77%, and 1.57% for the 0.40, 0.55, and 0.70 w/cm mixtures, respectively. Mechanical testing was performed to better assess the microcracking and paste softening from sulfate attack. Compressive strength testing of the specimens exposed to the sulfate solution was performed at 1, 3, 6, 12, and 24-months. The ultimate load was compared against control specimens tested at 1, 6, and 24-months. An increase in compressive load was observed for the 0.55 and 0.70 w/cm mixtures when compared against the control specimens for the 1 and 6-month ages. This is attributed to sulfate attack initiation, which forms solid crystalline sulfate products in the voids, initially resulting in a denser matrix. For the 0.55 and 0.70 w/cm mixtures, a decrease in strength

is not seen until one year after exposure. After the full exposure period of two years, a significant decrease of approximately 56% and 68% in strength was measured for the 0.55 and 0.70 w/cm mixtures respectively, when compared to the 1-month exposure values. The compressive load for the 0.40 w/cm mixture remained relatively consistent for all ages tested, indicating the low w/cm is more sulfate resistant. The failure mechanism during compression loading was also recorded and it was noted that the specimen half exposed to solution was weaker than the half exposed to the atmosphere. The visual inspection showed less deterioration in the submerged half, suggesting that appearances can be misleading and that physical expansion or visual ratings are not adequate for evaluating sulfate attack. The splitting tensile strength results showed a decrease in load capacity for all three mixtures from the beginning of the exposure period. Due to the uneven deterioration across the length of the cylinder, the splitting tensile test method was found to be inadequate.

Table 32. Summary of required equipment and approximate costs using the partial immersion sulfate exposure of concrete specimens proposed by Hartell et al. [78].

Non-Consumables – Approximate Cost		Consumables – Approximate Cost		
<ul style="list-style-type: none"> Soaking tanks for partial immersion – \$150 (50 gal. stock tanks similar to Rubbermaid FG424300BLA) 		<ul style="list-style-type: none"> Sodium sulfate solution¹ – \$150 		
Total Approximate Cost ² : \$300				
≤ 30 Days	Concrete	≤ \$30,000	Uncomplicated	No Hazards
X	✓	✓	✓	✓

¹ Anhydrous sodium sulfate can be purchased as technical grade (generally 85-90% purity) for approximately \$6.25/kg from Spectrum Chemical, and reagent grade (99%) from Spectrum costs \$19/kg. However, natural food grade (99%) anhydrous sodium sulfate can be obtained for approximately \$2/kg. The volume of solution was not specified by Hartell et al. so an estimate is given. Also, if the solution is replaced periodically, the cost would increase.

² It is assumed that a concrete testing lab will have the requisite machinery to perform compression and splitting tension of 4 in. by 8 in. concrete cylinders.

Drawbacks of the Method:

The main drawback for the partial immersion test methods is the length required to indicate concrete performance when exposed to sulfate solutions. The study by Hartell et al. took two years to show a decrease in compressive loading capacity due to deterioration from sulfate attack for the higher w/cm concrete mixtures (0.55 and 0.70) and showed no change after two years for the 0.40 w/cm mixture [78].

4.3.6. Complete Immersion

Researchers have also investigated the sulfate durability of completely immersed concrete specimens [76], [77], [79], [110]. For complete immersion, sulfate ingress into the concrete occurs via diffusion. This test method is less representative of typical field conditions and less

conservative as it does not include physical sulfate (or salt) attack that occurs when an evaporative front is present.

A method for complete immersion to sulfate solutions was proposed by Park et al. 1999 [110]. In this method 4 in. by 8 in. concrete cylinders were cast and cured for 60 days by submersion prior to exposure. The cylinders were then separated into four groups to be submerged in: water, 10% sodium sulfate solution, 10% magnesium sulfate solution, and 10% sodium sulfate mixed with 10% magnesium sulfate solution. The strength of the concrete specimens was measured at 60, 90, 120, 150, 210, and 270 days, (the soak solutions would be drained and replaced every 30 days). The results showed that the magnesium sulfate was a dramatically more extreme exposure case than the sodium sulfate solution (with the combined solution being slightly worse than the magnesium sulfate solution). While Park et al. only investigated mixes containing silica fume as an SCM, they showed that the silica fume was beneficial for sodium sulfate exposure; however, the silica fume made the mixtures more susceptible to total compressive strength loss when exposed to magnesium sulfate (for instance, the 15% silica fume mixtures stored in sodium sulfate lost approximately 6% compressive strength from 60 to 270 days, while the mix stored in magnesium sulfate over the same period lost approximately 70% compressive strength).

Park et al. also measured the mass change and length change using 2 in. cube specimens; to accomplish this, coarse aggregate was kept to a maximum of 0.75 in. The exposure conditions of the cubes and cylinders was the same, and length change measurements were performed at 150 days and 270 days of age whereas weight changes were measured at 90 and 210 days. The results of this investigation showed that the length change associated with magnesium sulfate exposure was nearly identical for all mixes regardless of silica fume content (approximately 0.38%) at 150 days. At 270 days, in agreement with compressive strength loss, the increase in silica fume content corresponds to larger linear expansions of approximately 0.65% for 0% silica fume to 1.55% for 15% silica fume. Sodium sulfate exposed specimens shows the opposite trends where increasing silica fume content reduces linear length change at both 150 and 270 days. For the mass loss specimens, the weight change of specimens in sodium sulfate was negligible regardless of silica fume content at 90 days; but similar to the linear length change, silica fume content was strongly related to magnesium sulfate susceptibility with higher silica fume contents losing up to 20% mass at 210 days. Therefore, it is recommended that sulfate susceptibility can be evaluated without investigating linear length change and mass loss of concrete cubes. A summary of the approximate costs to perform the method proposed by Parks et al. is shown in Table 33.

Table 33. Summary of required equipment and approximate costs using the complete immersion sulfate exposure of concrete specimens proposed by Park et al. [110].

Non-Consumables – Approximate Cost		Consumables – Approximate Cost		
<ul style="list-style-type: none"> Soaking tanks, 4 – \$300 (50 gal. stock tanks similar to Rubbermaid FG424300BLA) 	<ul style="list-style-type: none"> Sodium sulfate solution (need approximately 650 L of solution for 7 solution changes)¹ – \$150 - \$2,000 Magnesium sulfate solution (need approximately 650 L of solution for 7 solution changes)² – \$330 - \$2,500 4 in. by 8 in. cylinder molds, 72 ea. test – \$65 	Total Approximate Cost ³ : \$850 - \$5,000		
≤ 30 Days	Concrete	≤ \$30,000	Uncomplicated	No Hazards
X	✓	✓	✓	✓

¹ Anhydrous sodium sulfate can be purchased as technical grade (generally 85-90% purity) for approximately \$6.25/kg from Spectrum Chemical (71 kg is necessary for this experiment based on 650 L and mol/L solute required [111]). Reagent grade (99%) from Spectrum cost \$19/kg. However, natural food grade (99%) anhydrous sodium sulfate can be obtained for approximately \$2/kg.

² Anhydrous magnesium sulfate can be purchased (97% purity) for approximately \$17/kg from CP Lab Safety (72 kg is necessary for this experiment based on 650 L and mol/L solute required [112]). Reagent grade (99%) from Spectrum Chemical cost \$35/kg. However, Epsom salt (magnesium sulfate heptahydrate) can be purchase, and dosed at 204% the anhydrous dose (requiring 147 kg of Epsom salt); this can be purchased in bulk for approximately \$2.25/kg.

³ It is assumed that a concrete testing lab will have the requisite machinery to perform compression of 4 in. by 8 in. concrete cylinders.

Drawbacks of the Method:

The largest drawback of the exposure method proposed by Park et al. 1999 is the length of time required to obtain results is approximately 9 months. Additionally, there is a large volume of chemical reagents to dispose of. The other complete immersion test methods are also long-term methods that take months or years to show results of concrete sulfate durability.

4.4. TRANSPORT PROPERTY

4.4.1. AASHTO PP 84

AASHTO PP 84 - *Standard Practice for Developing Performance Engineered Concrete Pavement Mixtures*, is a standard that specifies the performance characteristics of concrete pavement mixtures with respect to strength, warping and cracking, freeze-thaw durability, transport, aggregate stability, and workability [113]. The performance specification for freeze-thaw durability and transport properties defines the use of the apparent formation factor (F_{APP}), which is the ratio of the resistivity of the bulk body (ρ) to the resistivity of the pore solution in the body (ρ_o). The formation factor is a fundamental property that can be determined using electrical test methods and related to the time to corrosion initiation [114].

AASHTO PP 84 specifies that the bulk resistivity be obtained at 91 days according to AASHTO TP 119 with conditioning option A (the current iteration of AASHTO T 119 does not make mention of conditioning options; however, the standard is under revision and the intent is to consider conditioning of specimens in simulated pore solution as “option A” in the next version of AASHTO T 119). The pore solution resistivity is assumed to be 0.127 Ω-m based on the conditioning procedure that is used. For concrete that is not subjected to freezing and thawing cycles or deicer application, the F_{APP} should be greater than 500. For concrete exposed to freeze-thaw and deicers, the F_{APP} should be greater than 1,000. The advantage of using the formation factor over the surface or bulk resistivity is that the pore solution resistivity is taken into account; however, assuming one pore solution resistivity value for concrete mixtures may not be accurate for alternative SCMs. A summary of the approximate costs to determine the formation factor according to AASHTO PP 84 for one set of specimens is provided in Table 34.

Table 34. Summary of required equipment and approximate costs using the formation factor per AASHTO PP 84¹.

Non-Consumables – Approximate Cost		Consumables – Approximate Cost		
• Resistivity apparatus – \$3,500		• Conductive medium – \$5		
• Stainless steel plate electrodes – \$100				
• Connector cables – \$10				
• Conductive medium – \$5				
• Infrared thermometer – \$150				
Total Approximate Cost ² : \$3,750				
≤ 30 Days	Concrete	≤ \$30,000	Uncomplicated	No Hazards
X	✓	✓	1	✓

¹ The approximate costs assume that the pore solution resistivity is assumed and not calculated or measured. Calculating the pore solution resistivity would require knowledge of the mixture proportions, chemistry of the cementitious materials, and degree of hydration. Measuring the pore solution resistivity requires extensive resources for solution extraction and would not meet the FDOT criteria.

² If the resistivity apparatus is purchased for AASHTO T 358 and TP 119, the total additional cost to perform AASHTO PP 84 be approximately \$0.

Drawbacks of the method:

The main drawback for the formation factor using the performance criteria is the length of time for conditioning/curing. The standard specifies to measure the resistivity at 91 days to allow for the concrete to mature and pozzolans to react. Another factor to consider is whether it is accurate to assume the same value for the pore solution resistivity for concrete mixtures; different cement types and SCMs can alter the pore solution chemistry and thus resistivity. If the pore solution resistivity would need to be calculated from the chemistry makeup of the mixture or extracted from specimens to measure, the cost and level of complexity would increase significantly.

4.4.2. EN 12390 – Part 8/CRD-C 48-92/ACCI water permeability

Since chloride durability of concrete is largely dependent on the penetrability of the concrete matrix, water permeability test methods can be used to estimate durability. There are two principle categories of water permeability tests that have been used. The first category is for methods that measure water penetration depth over a defined period of time. The second category is water flow-through tests that measure flow rate until steady state is achieved. For both categories, a uniaxial, pressurized water gradient is applied to one surface of the specimen. Water permeability measurements of concrete can have high variability and require care to obtain accurate results, but can give an indication of the interconnectivity of the capillary pores and the quality of concrete [115]–[117]. Some of the variability, especially at early ages, is due to the continued hydration of the specimens during testing; this can make it difficult to reach steady-state flow [115].

Penetration depth test methods are relatively short-term tests that apply water pressure to the specimens for 3–4 days before splitting the specimen and measuring the penetration depth. The applied pressure gradient for these methods ranges from 65 to 80 psi, but is typically reported as the average, 72.5 psi. Although not a direct measurement of water permeability, the penetration depth gives a good indication of the permeability of the specimen. Because these methods do not saturate or seal the specimens, the depth of penetration is due in part to water absorption. The most common standardized test method used in this category is EN 12390 – Part 8 – Depth of penetration of water under pressure [118].

Because water pressure is only applied for 3–4 days, the specimen sides do not need to be sealed. However, to ensure flow does not leak out of the sides, there are minimum specified dimensions. EN 12390-8 requires the surface of the specimen to be tested to have a minimum dimension of 150 mm (6 in.) and no other dimension less than 100 mm (4 in.) [118]. An example of an unsealed specimen setup for water penetration depth testing is shown in Figure 28. The water inlet is at the bottom and a watertight O-ring seals the test area to be approximately half the dimension of the surface of the specimen; the reduced test area helps prevent flow from occurring out of the specimen sides. However, specimens with high permeability may still have leakage out of the sides, in which case, this test method is not appropriate. After the specified period of 3–4 days, the specimens are split in half and the maximum depth of water penetration is measured. Because of specimen drying on the sides and pressurized water only applied to the center half of the sample, water penetration depth will not be uniform throughout the cross-section. The water penetration depth is measured to be the maximum depth penetrated.

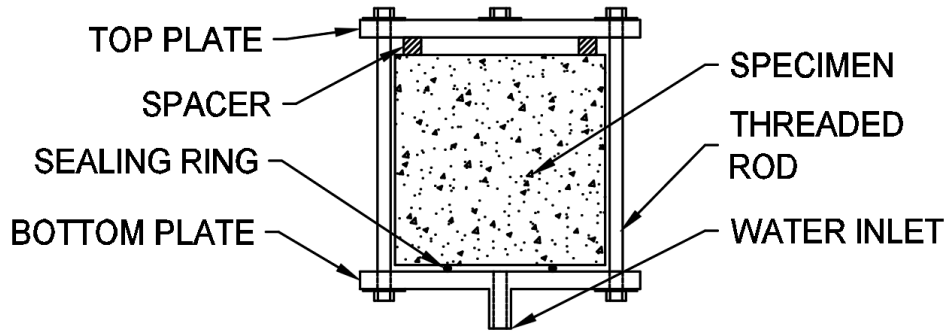

Figure 28. Diagram of unsealed specimen for water penetration depth test per EN 12390-8 [118].

Steady-state water permeability test methods use the flow rate during testing to calculate the permeability. Permeability is calculated using Darcy's law, which relates the flow to the hydraulic pressure gradient for steady-state, laminar flow through a saturated porous medium [47], [48], [119]. While this category of test methods directly measures the water permeability, there are drawbacks. The first is that the test takes a long time to conduct and depends on the quality of concrete tested; steady state is typically achieved in 14-20 days, but high quality concrete, with low permeability, may take longer or exhibit no flow. Another factor to consider is that there is continued hydration during the testing period, consequently it is difficult to achieve steady-state flow, especially for early ages. Specimens can be vacuum saturated prior to testing to reduce the time to reach steady-state conditions. Two water permeability flow-through test methods include the CRD-C 48-92 - *Standard test method for water permeability of concrete* [120] and ACCI water permeability test [121].

The U.S. Army Corps of Engineering developed the first standardized water permeability test in the early 1970s as CRD-C 48-73, which is now CRD-C 48-92 [120], [122]. According to CRD-C 48-92, the sides of the specimens are first sealed with a paraffin-rosin mixture before securing the specimens in the testing chamber [120]. The specimens are secured using additional paraffin-rosin, plaster, and asphalt to ensure a good seal around the perimeter. A water pressure of 200 psi is then applied to the specimen via a water inlet and the resulting flow rate is measured until steady-state is achieved, typically 14-20 days. A full schematic of the water permeability test assembly for CRD-C 48-92 is shown in Figure 29.

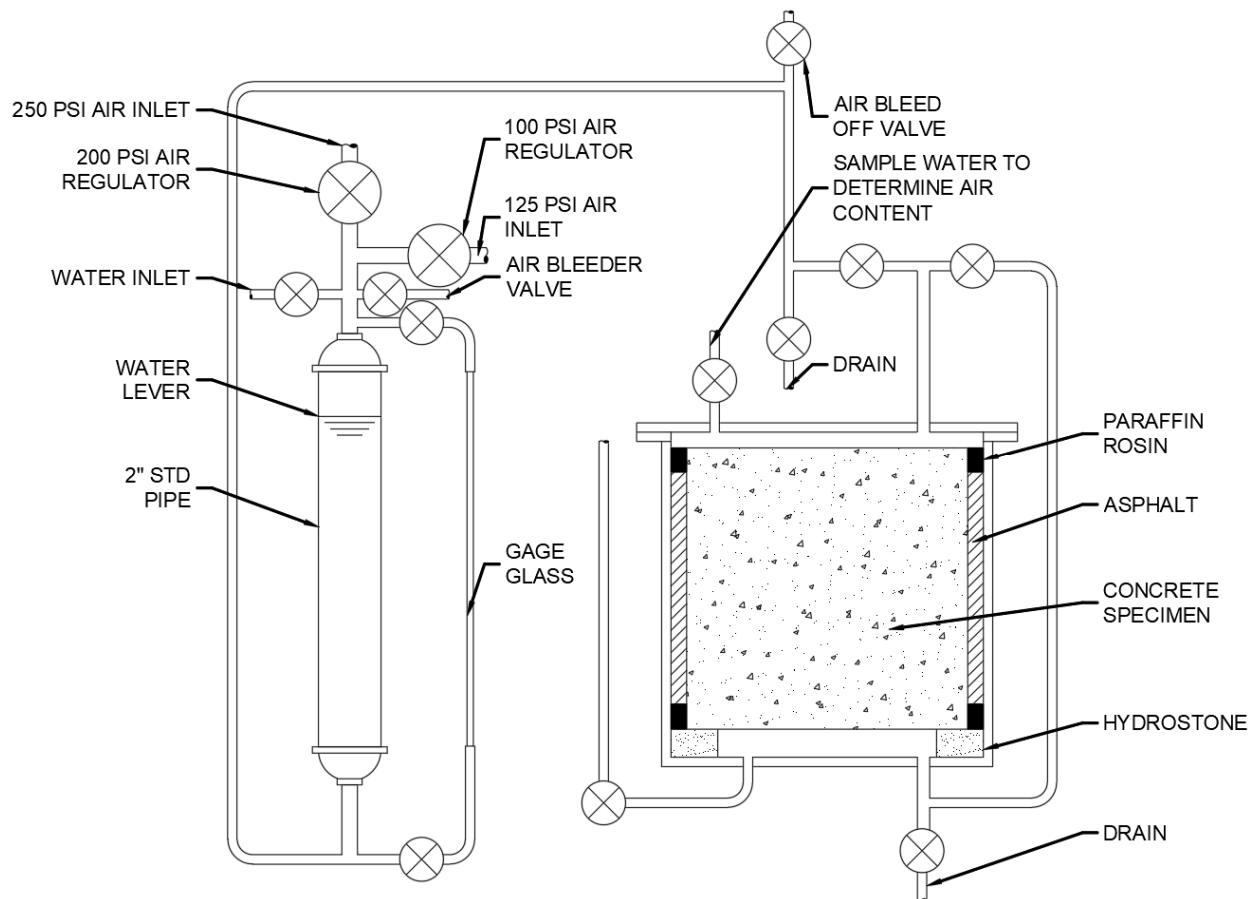

Figure 29. Diagram of water permeability test assembly for CRD-C 48-92 [120].

The ACCI water permeability test was adapted from the Taywood test and also measures flow rate under constant pressure to calculate permeability directly [121], [123]. This test appears to be similar in many ways to the method developed at the University of Florida [117], [119]. As part of an FDOT research program to create concrete durability specifications and ratings for Florida, a constant pressure, steady-state flow permeameter was developed [49], [116], [117]. For this method, a 2 in. thick slice of concrete is taken from a 4 in. diameter concrete cylinder, and the perimeter is coated with a 1 in. layer of epoxy. The epoxy ring restricts flow through only the face of the specimen and provides a bearing surface for sealing the specimens with an O-ring between two acrylic plates on the top and bottom as shown in Figure 30. Once the concrete specimen is secured in the cell, it is attached to a manometer tube, filled with water, and pressurized. The rate of water flow through the specimen is calculated by measuring the drop in water level in the manometer tube over time. Steady-state flow is usually reached in one to three weeks, after which the test is continued for an additional five to seven days, taking water flow measurements at 24-hour intervals [116], [117]. The water pressure for these test methods ranges from 85 to 145 psi. A summary of the approximate costs to run ASTM C1585 for one set of specimens is provided in Table 35.

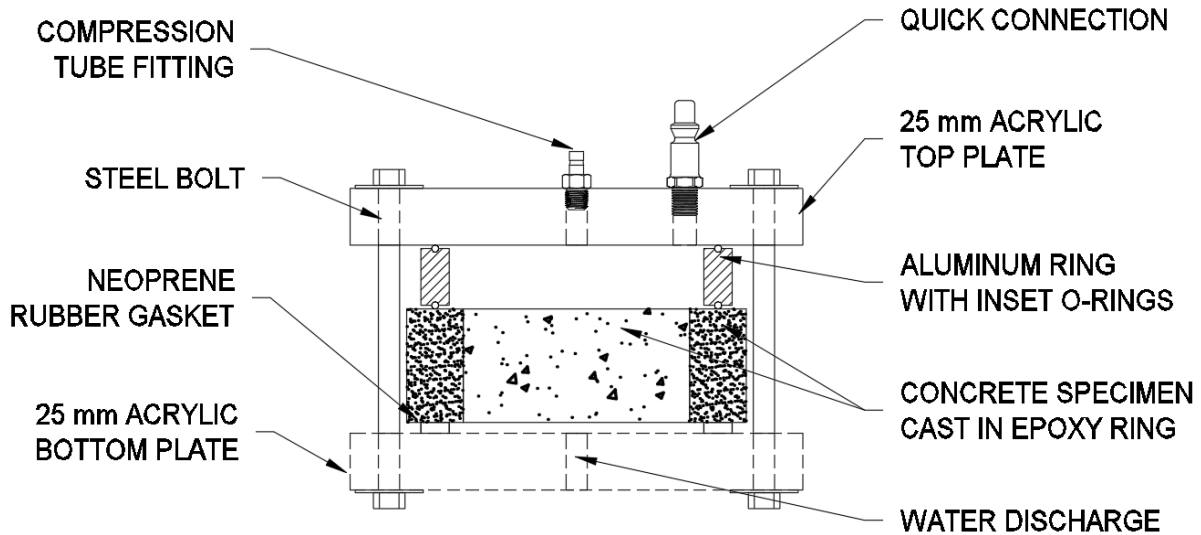

Figure 30. Diagram of University of Florida water permeability cell with concrete specimen cast in epoxy ring (similar to the ACCI water permeability test).

Table 35. Summary of required equipment and approximate costs using water permeability test methods.

Non-Consumables – Approximate Cost		Consumables – Approximate Cost		
• Air compressor – \$2,500 - \$8,000		• Specimen sealant ¹ – \$50		
• Pressurized water supply tank – \$250 - \$500				
• Pressure regulators, valves, tubing, and connections – \$1,000 - \$5,000				
• Top and bottom plates – \$400 - \$1,000				
• O-rings and gaskets – \$50				
• Bolts, nuts, and washers – \$50				
• Manometer backing board and hardware to track flow over time ¹ – \$500				
Total Approximate Cost:		\$5,000 - \$15,250		
≤ 30 Days	Concrete	≤ \$30,000	Uncomplicated	No Hazards
X	✓	✓	X	✓

¹ Required for the flow-through test methods.

Drawbacks of the method:

Water permeability measurements of concrete can have high variability, consequently care should be taken with specimen conditioning and flow/penetration measurement to obtain accurate results [116], [124], [125]. Some tests are not able to measure water flow below a threshold water permeability; for these tests, specimens that show no water flow do not

necessarily mean that the concrete is impervious, only that the test is not capable of measuring the flow. Caution is thus urged in interpreting water permeability results.

4.4.3. ASTM C1585

Water absorption is one of the easiest and most efficient means for assessing concrete penetrability [49], [126], which can provide an indication of chloride durability. ASTM C1585 - *Standard Test Method for Measurement of Rate of Absorption of Water by Hydraulic-Cement Concretes*, determines the rate of absorption by measuring the increase in mass of a specimen over time that is exposed to water [127]. At least two cylindrical specimens are required for the method to take an average; the specimens are 4 in. dia. x 2 in. tall (100 mm dia. x 50 mm tall).

The test method does not specify a curing regime or time; however, to obtain a measurement of absorption as it relates to durability, the concrete would have to be matured before testing. Before exposing to water, the specimens are conditioned by placing the specimens in an environmental chamber at $50 \pm 2^\circ\text{C}$ and relative humidity of $80 \pm 3\%$ for three days. Alternatively, the specimens can be placed in a desiccator inside an oven to the same temperature and relative humidity. After the three days, each specimen is placed in its own sealable container for at least 15 days at $23 \pm 2^\circ\text{C}$ [127].

Subsequent to the conditioning procedure, the specimen is weighed, the dimensions are measured, and the sides are sealed with low permeability adhesive sheets or similar sealant. The top surface is also loosely sealed with a plastic sheet. The sealed specimen is then weighed and placed on supports inside a container with the water level maintained 1 to 3 mm above the top of the supports as shown in Figure 31. Once the specimen is placed on the supports, in contact with water, a timer is started and the specimen is weighed at intervals specified in the standard. The specimens are measured over nine days, and the absorption is calculated as the change in mass divided by the product of the cross-sectional area of the test specimen and the density of water. The calculated absorption can be used to find the initial absorption rate and secondary absorption rate. A summary of the approximate costs to run ASTM C1585 for one set of specimens is provided in Table 36.

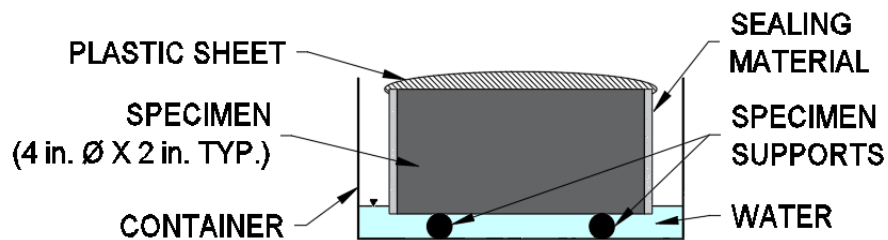

Figure 31. Diagram of partial water exposure for water absorption test ASTM C1585 [127].

Table 36. Summary of required equipment and approximate costs using ASTM C1585.

Non-Consumables – Approximate Cost		Consumables – Approximate Cost		
<ul style="list-style-type: none"> • Environmental chamber able to maintain a temperature of $50 \pm 2^\circ\text{C}$ and a relative humidity at $80 \pm 3\%$ – \$10,000 - \$20,000 • Container/pan – \$10 • Specimen supports – \$10 • Polyethylene storage containers with sealable lids – \$10 • Caliper with precision of 0.1 mm – \$100 		<ul style="list-style-type: none"> • Sealing material – \$5 • Plastic sheets – \$5 		
Total Approximate Cost:		\$10,250 - \$20,250		
≤ 30 Days	Concrete	$\leq \$30,000$	Uncomplicated	No Hazards
X	✓	✓	✓	✓

Drawbacks of the method:

While water absorption tests are easy measurements of concrete penetrability, the test method cannot be completed within 30 days. Furthermore, differences in specimen conditioning can result in different absorption values. A study by Zhutovsky and Hooton investigated the importance of sample preparation in water absorption tests by comparing the effect of two drying procedures used in standard test methods [126]; it was concluded that drying at 60°C until constant mass was a more appropriate conditioning procedure and had better correlation with other transport properties [126]. Castro et al. also examined the specimen conditioning procedure used prior to water absorption testing and found that the conditioning procedure, specifically the relative humidity, can substantially influence the results [128]. Specimens with a lower relative humidity before the start of the test showed higher total absorption [128], [129]. Another factor that can influence the results is the aggregate content; specimens with higher cement paste content will absorb more water [128].

4.4.4. ASTM C642

ASTM C642 - *Standard Test Method for Density, Absorption, and Voids in Hardened Concrete* measures the oven-dry mass, saturated mass after immersion, saturated mass after boiling, and immersed apparent mass of a concrete sample to estimate the penetrability [130]. The sample should consist of several individual portions of concrete. The method does not specify dimensions, but each individual portion must have a volume of at least 350 cm^3 and be free of cracks, fissures, and shattered edges.

The initial mass of the sample is taken before placing the sample in an oven at $110 \pm 5^\circ\text{C}$ for at least 24 hours. The sample is then removed from the oven and allowed to cool to ambient temperature. The mass is measured again and the 24-hr. drying period is repeated until the difference between any two successive values is less than 0.5% of the lowest value. The last value is designated as the oven-dry mass. The sample is then immersed in water at approximately

21°C for at least 48 hours until two successive measurements show an increase in mass of less than 0.5%. The sample is measured surface-dry and this mass is designated the saturated after immersion. Next, the sample is placed in a container, covered with water, and boiled for five hours. After boiling, the sample is left in the water to cool for at least 14 hours to a final temperature of 20 to 25°C. The sample is removed from the water, surface-dried and the mass is measured. Finally, the sample is suspended in water to determine the apparent mass. The values for mass are used to calculate the absorption, density, and volume of permeable voids. A summary of the approximate costs to run ASTM C642 for one set of specimens is provided in Table 37.

Table 37. Summary of required equipment and approximate costs using ASTM C642.

Non-Consumables – Approximate Cost		Consumables – Approximate Cost		
<ul style="list-style-type: none"> • Benchtop scale, 0.1g precision – \$650 (similar to Humboldt Mfg Model HB-4730) • Benchtop desiccator – \$200 • Hot plate – \$700 (similar to Corning 6798600D) • Stock pot for boiling – \$20 				
Total Approximate Cost: \$1,400				
≤ 30 Days	Concrete	≤ \$30,000	Uncomplicated	No Hazards
X	✓	✓	✓	✓

Drawbacks of the method:

Although ASTM C642 does not specify a curing time, the concrete would have to reach maturity before testing to estimate the durability and thus could not be completed within 30 days. Additionally, the harsh oven drying and boiling procedures may induce cracking in the specimen and alter the absorption and permeable voids measured.

4.5. SUMMARY

A summary of the available testing methods for measuring cracking tendency of concrete and the applicability to FDOT requirements for implementation is presented in Table 38. Due to the time required for concrete containing SCMs to reach maturity, none of the durability test methods met the 30-day criteria.

For chloride durability, AASHTO T 358 and AASHTO TP 119 are recommended for further investigation. These electrical resistivity methods are quick, easy, and cheap to conduct making them ideal for quality control testing. There is still a need to develop novel accelerated curing methods to more accurately represent mature concrete with SCMs within a reasonable timeframe. Additionally, the pore solution conductivity should be taken into account by using the formation factor or using a simulated pore solution during curing.

For sulfate durability, there are currently no standardized test methods that measure concrete specimens for sulfate resistance. Tumidajski and Turc (1995) developed a rapid sulfate electrochemical test method based on ASTM C1202 that used concrete specimens. While the test method only takes six hours, the curing period to allow for the pozzolanic reaction to occur to achieve mature concrete exceeds 30 days.

Additionally, general transport property test methods were evaluated as a means for predicting durability. AASHTO PP 84 is a performance specification that includes formation factor for determining transport properties and should be investigated further.

Table 38. Summary of criteria for durability test methods.

		≤ 30 Days	Concrete	≤ \$30,000	Uncomplicated	No Hazards
Chloride	ASTM C1202/ AASHTO T 277	X	✓	✓	✓	✓
	NT Build 492	X	✓	✓	✓	X
	AASHTO T 358	X	✓	✓	✓	✓
	AASHTO TP 119	X	✓	✓	✓	✓
Sulfate	USBR 4908	X	✓	✓	✓	✓
	MNS Method	X	1	✓	✓	✓
	Soaking and Drying	X	✓	✓	✓	✓
	Rapid Sulfate Electrochemical	X	✓	✓	✓	✓
	Partial Immersion	X	✓	✓	✓	✓
	Complete Immersion	X	✓	✓	✓	✓
Transport	AASHTO PP 84	X	✓	✓	2	✓
	EN 12390-8/ CRD-C 48-92/ACCI	X	✓	✓	X	✓
	ASTM C1585	X	✓	✓	✓	✓
	ASTM C642	X	✓	✓	✓	✓

¹This method is purported to be performed on concrete, however the small specimen cross-section would limit the nominal maximum aggregate size to approximately 0.5 in. Increasing the specimen size would necessitate larger molds, storage containers, refrigerators, tension machines (with larger capacities) and considerably larger grips. All of which would immediately make this method cost more than \$30,000.

²The approximate costs assume that the pore solution resistivity is assumed and not calculated or measured. Calculating the pore solution resistivity would require knowledge of the mixture proportions, chemistry of the cementitious materials, and degree of hydration. Measuring the pore solution resistivity requires extensive resources for solution extraction and would not meet the FDOT criteria.

5. MAIN FINDINGS, CONCLUSIONS, AND RECOMMENDATIONS

5.1. MAIN FINDINGS

The objective of this project was to perform a thorough literature review to determine if there are existing test methods that can quantify the performance of concrete with respect to heat evolution, cracking, and durability at the mix design phase. Test methods were evaluated based on the following criteria:

- Testing will be conducted on conventional portland cement concrete containing coarse aggregate – not mixture components, derivatives, or specialty mixes (e.g., paste, mortar, grout, UHPC, RCC).
- The time for completion does not exceed 30 days for testing.
- The testing techniques do not utilize any hazardous materials.
- Tests are relatively uncomplicated – a person with a high-school education can perform.
- Cost of testing equipment should support a wide deployment – total cost not to exceed \$30,000.00.

The project reviewed the available literature related to testing of concrete to assess potential for excessive shrinkage, potential to experience excessive temperature rise, and chloride and sulfate durability. The research team categorized identified test methods into categories as follows:

- Category I – Test meets current needs of FDOT without any modifications.
- Category II – Test can be modified to successfully meet FDOT needs.
- Category III – Test shows some potential to meet FDOT needs, but does not meet one of the main criteria listed above.

Based upon the exhaustive literature search performed, Table 39 classifies the test methods that are considered for concrete evaluation and prescribes a Category classification as per the criteria above. There are additional summary notes for a select number of tests to clarify modifications that could allow the implementation of a test, why a test or family of tests is unlikely to be accepted, or why a test may meet the criteria outlined but is still not recommended as the main evaluation method.

Table 39. Summary table of test methods and FDOT category classification.

Evaluation Type	Method	Category	Notes
Adiabatic heat rise	USBR Method	III	These adiabatic tests are complicated and expensive. Considerable development would need to be done to create meet the needs of FDOT.
	RILEM Method	III	
	CRD-C 38-73	III	
Semi-adiabatic heat rise	RILEM Method	III	Modification of the sample size (and container) would be needed to obtain more accurate results.
	LCPC QAB	II	

Table 39, continued.

Evaluation Type	Method	Category	Notes
	NT Build 388	III	
Isothermal calorimetry		III	No standard method exists for determining heat of hydration of concrete
Restrained shrinkage	ASTM C1581	III	
	AASHTO T 334	II	This method would need a slight modification of the apparatus to allow larger concrete specimens to account for larger aggregate sizes or to disallow the use of a standard pipe for the mold.
	AASHTO T 363	III	
	Cracking Frame	III	
	NT Build 433	III	
	ASTM C1579	III	
Unrestrained shrinkage	ASTM C157/ AASHTO T 160	III	
	AASHTO T 336	I	While these methods meet the FDOT criteria, these methods do not provide quantitative cracking tendency of concrete. The results obtained from these tests can only be used as a supplement to restrained shrinkage tests for evaluating cracking tendency of concrete.
	ASTM C827	I	
Chloride durability	ASTM C1202/ AASHTO T 277	III	The chloride, sulfate, and transport related test methods have the same flaw: they are incapable of accurately evaluating concrete mixes with supplementary cementitious materials at 30 days or less. This is a function of hydration chemistry with supplementary cementitious materials taking time to mature, in addition to several of the degradation mechanisms (specifically sulfate deterioration) taking additional time to crystalize and degrade concrete. Development of rapid/accelerated curing regimes would need be investigated prior to the inclusion of a durability related test method being incorporated into an FDOT quality control program. Current work is being performed under AASHTO TP-84 investigating accelerated curing methods for durability exposure tests.
	NT Build 492	III	
	AASHTO T 358	III	
	AASHTO TP 119	III	
Sulfate durability	USBR 4908	III	
	MNS Method	III	
	Soaking-Drying	III	
	Rapid Sulfate Electrochemical	III	
	Partial Immersion	III	
	Complete Immersion	III	
Transport properties	AASHTO PP 84	III	
	EN 12390-8/ CRD-C 48-92/ACCI	III	
	ASTM C1585	III	
	ASTM C642	III	

A combined summary of the chapter summary tables for each method is presented below in Table 40 for convenience.

Table 40. Final summary table of experimental methods.

		≤ 30 Days	Concrete	≤ \$30,000	Uncomplicated	No Hazards
Adiabatic	USBR Method	✓	✓	X	X	✓
	RILEM Method	✓	✓	✓	X	✓
	CRD-C 38-73	✓	✓	X	X	✓
Semi-adiabatic	RILEM Method	✓	✓	✓	✓	✓
	LCPC QAB	✓	✓	✓	✓	✓
	NT Build 388	✓	✓	✓	✓	✓
Isothermal	No standard method exists for determining heat of hydration of concrete					
	ASTM C1581	✓	0.5 in. Nominal Maximum Aggregate Size	✓	✓	✓
	AASHTO T 334	✓	~1.0 in. Nominal Maximum Aggregate Size	✓	✓	✓
	AASHTO T 363	✓	~0.5 in. Nominal Maximum Aggregate Size	✓	✓	✓
	Cracking Frame	✓	✓	X	X	✓
	NT Build 433	✓	~0.625 in. Nominal Maximum Aggregate Size	✓	✓	✓
	ASTM C1579	✓	✓ ¹	X	✓	✓
Unrestrained	ASTM C157/ AASHTO T 160	X	✓	✓	✓	✓
	AASHTO T 336	✓	✓	✓	✓	✓
	ASTM C827	✓	✓	✓	✓	✓

Table 40, continued.

		≤ 30 Days	Concrete	≤ \$30,000	Uncomplicated	No Hazards
Chloride	ASTM C1202/ AASHTO T 277	X	✓	✓	✓	✓
	NT Build 492	X	✓	✓	✓	X
	AASHTO T 358	X	✓	✓	✓	✓
	AASHTO TP 119	X	✓	✓	✓	✓
Sulfate	USBR 4908	X	✓	✓	✓	✓
	MNS Method	X	2	✓	✓	✓
	Soaking and Drying	X	✓	✓	✓	✓
	Rapid Sulfate Electrochemical	X	✓	✓	✓	✓
	Partial Immersion	X	✓	✓	✓	✓
	Complete Immersion	X	✓	✓	✓	✓
Transport	AASHTO PP 84	X	✓	✓	3	✓
	EN 12390-8/ CRD-C 48- 92/ACCI	X	✓	✓	X	✓
	ASTM C1585	X	✓	✓	✓	✓
	ASTM C642	X	✓	✓	✓	✓

¹ This test method is specifically designed to determine the effectiveness of fiber reinforced concrete in comparison to comparable mixes without fiber reinforcement. Therefore, it is not directly applicable to the majority of concrete mixes; however, it may be able to be modified.

² This method is purported to be performed on concrete, however the small specimen cross-section would limit the nominal maximum aggregate size to approximately 0.5 in. Increasing the specimen size would necessitate larger molds, storage containers, refrigerators, tension machines (with larger capacities) and considerably larger grips. All of which would immediately make this method cost more than \$30,000.

³ The approximate costs assume that the pore solution resistivity is assumed and not calculated or measured. Calculating the pore solution resistivity would require knowledge of the mixture proportions, chemistry of the cementitious materials, and degree of hydration. Measuring the pore solution resistivity requires extensive resources for solution extraction and would not meet the FDOT criteria.

5.2. CONCLUSIONS

Based on the literature reviewed, the following conclusions were drawn from this study:

- The best available testing method for determining cracking is the Standard Method of Test for Estimating Cracking Tendency of Concrete as per AASHTO T 334. The method has a provision that allows for a standard size pipe to be used to construct the mold, if

this provision is disallowed (or the rest of the mold is made bigger) to allow a 3 in. minimum specimen thickness, this specification would meet all of the FDOT criteria.

- The best available testing method for determining the heat production and resultant temperature rise of concrete is the LCPC QAB semi-adiabatic calorimetry test method. The test provides the most robust data due to the large specimen size; however, modifications to allow for larger sizes would need to be developed prior to full adoption by FDOT.
- The chloride and sulfate durability testing methods require further evaluation and development prior to being accepted with FDOT criteria; the largest barrier to acceptance is the 30-day requirement in combination with the ability to test concrete mixes with supplementary cementitious materials.
- Some of the standard testing methods summarized in Table 39 may meet all of the FDOT criteria but do not give adequate testing information based on the available literature.
 - Methods for semi-adiabatic heat rise meet all of the criteria, but the data obtained is insufficient for a quality control program.
 - Methods regarding unrestrained shrinkage similarly meet FDOT requirements, but the amount of information is limited to one or two forms of shrinkage, and is not directly applicable to reinforced or restrained scenarios which comprise the majority of FDOT applications.

5.3. RECOMMENDATIONS

Based upon the findings from this study, the following recommendations are made:

- Develop and create precision statement for a Florida Method based on AASHTO T 334 that does not allow for a standard size pipe to be used to construct the mold; using a standard size pipe restricts the specimens size and thus the maximum aggregate size.
- Develop and create precision statement for a Florida Method based on the LCPC QAB semi-adiabatic calorimetry test method to allow for larger specimen sizes to ensure QA/QC at the design mix stage.
- For chloride and sulfate durability, fundamental research into the evaluation of accelerated curing regimes is required, especially for concrete using SCMs.
 - Further research should include investigation of the standard and accelerated curing methods prescribed in the Standard Practice for Developing Engineered Concrete Pavement Mixtures (AASHTO PP 84) for the acceptance of FDOT concrete. Currently, there is active research being performed with regards to accelerated curing methods as prescribed the Standard Test Method for Electrical Resistivity of a Concrete Cylinder Tested in a Uniaxial Resistance Test (AASHTO TP 119) and the Standard Method of Test for Determining the Pore Volume in Hardened Concrete Using Vacuum Saturation (AASHTO TP 135).

REFERENCES

- [1] P. B. Bamforth, "Mass Concrete," *Concrete Society Digest*, p. 9, 1984.
- [2] J. Gajda and M. Vangeem, "Controlling temperatures in mass concrete," *Concrete International*, vol. 24, no. 1, pp. 58–62, 2002.
- [3] ACI 207.2, "Report on Thermal and Volume Change Effects on Cracking of Mass concrete," American Concrete Institute, Farmington Hills, MI, 2007.
- [4] ACI-CT, "CT-18 Concrete Terminology." American Concrete Institute, 2018.
- [5] RILEM TC 119-TCE, "TCE1: Adiabatic and semi-adiabatic calorimetry to determine the temperature increase in concrete due to hydration heat of the cement," *Materials and Structures*, vol. 30, pp. 451–464, 1997.
- [6] C. Ferraro, "Determination of Test Methods for the Prediction of the Behavior of Mass Concrete," Dissertation, University of Florida, Gainesville, FL, 2009.
- [7] B. J. Lee, J. W. Bang, K. J. Shin, and Y. Y. Kim, "The Effect of Specimen Size on the Results of Concrete Adiabatic Temperature Rise Test with Commercially Available Equipment," *Materials*, vol. 7, pp. 7861–7874, 2014.
- [8] ASTM C1679, "Standard Practice for Measuring Hydration Kinetics of Hydraulic Cementitious Mixtures Using Isothermal Calorimetry," ASTM International, West Conshohocken, PA, 2017. [Online]. Available: <http://www.astm.org/Standards/C1679.htm>.
- [9] USBR, "Procedure For Temperature Rise of Concrete," United States Department of the Interior - Bureau of Reclamation, Denver, CO, USA, USBR 4911-92, 1992.
- [10] ASTM A123, "Standard Specification for Zinc (Hot-Dip Galvanized) Coatings on Iron and Steel Products," ASTM International, West Conshohocken, PA, 2017.
- [11] ASTM A625, "Standard Specification for Tin Mill Products, Black Plate, Single-Reduced," ASTM International, West Conshohocken, PA, 2018.
- [12] ASTM A650, "Standard Specification for Tin Mill Products, Black Plate, Double Reduced," ASTM International, West Conshohocken, PA, 2018.
- [13] CRD-C 38-73, "Method of Test for Temperature Rise in Concrete." U.S. Army Corps of Engineers, 1973.
- [14] EN 12390 - 15, "Testing Hardened Concrete - Adiabatic Method for the Determination of Heat Released by Concrete During Its Hardening Process." CEN European Committee for Standardization, 2019.
- [15] Products Engineering Inc., "SURE CURE Pricing." <http://www.concret curing.com/Pricing/pricing.html> (accessed Jan. 05, 2021).
- [16] P. Acker, "Thermal effect in concrete during manufacture and applications to engineering structures," in *Annales de l'Institut Technique du Bâtiment et des Travaux Publics*, 1986, vol. 442, pp. 61–80.
- [17] C. Boulay, J. M. Torrenti, J. L. Andre, and R. Saintilan, "Quasi-adiabatic calorimetry for concretes: Influential factors," *Bulletin des laboratoires des ponts et chaussées*, no. 278, p. pp-19, 2010.
- [18] Nordtest, "Concrete: Heat Development (NT BUILD 388)," Finland, 1992. [Online]. Available: <http://www.nordtest.info/wp/1992/03/22/concrete-heat-development-nt-build-388/>.
- [19] C. C. Ferraro, "Advanced Nuclear Technology: Mass Concrete Modeling and Thermal Control: Investigation of Delayed Ettringite Formation and Thermal Cracking in Massive

- Concrete Structures,” Electric Power Research Institute, Charlotte, NC, 3002007577, 2018.
- [20] EN 12390 - 14, “Testing Hardened Concrete - Adiabatic Method for the Determination of Heat Released by Concrete During Its Hardening Process.” CEN European Committee for Standardization, 2019.
- [21] ASTM C1753, “Standard Practice for Evaluating Early Hydration of Hydraulic Cementitious Mixtures Using Thermal Measurements,” ASTM International, West Conshohocken, PA, 2015. doi: 10.1520/C1778-16.
- [22] Contech Analysis Aps, “Heat-Box,” *Heat-Box*. <http://b4cast.com/heatbox/heatbox.html> (accessed Jan. 05, 2021).
- [23] Calmetrix, Inc., “F-Cal 8000,” *F-Cal Semi-Adiabatic Calorimeter*. <https://www.calmetrix.com/f-cal-8000> (accessed Jan. 06, 2021).
- [24] TA Instruments, “TAM Air Brochure.” TA Instruments, [Online]. Available: <https://www.tainstruments.com/wp-content/uploads/TAM-AIR-brochure.pdf>.
- [25] Calmetrix, Inc., “Product line up and specifications.” Calmetrix, [Online]. Available: http://downloads.calmetrix.com/Specs/Calmetrix_Product_Line-up_and_Specifications-Cement.pdf.
- [26] “Concrete Calorimeter ToniCAL | Toni Technik GmbH,” *Toni Technik*. <https://tonitechnik.com/product/concrete-calorimeter-tonical-model-7336/> (accessed Jan. 05, 2021).
- [27] S. Kosmatka and B. Wilson, *Design and Control of Concrete Mixtures*, 16th ed. Skokie, IL: Portland Cement Association, 2016.
- [28] E. E. Holt, *Early age autogenous shrinkage of concrete*, vol. 446. Technical Research Centre of Finland Espoo, Finland, 2001.
- [29] T. A. Hammer, “Test methods for linear measurement of autogenous shrinkage before setting,” *Autogenous shrinkage of concrete*, pp. 143–154, 1999.
- [30] ASTM C1581, “Standard Test Method for Determining Age at Cracking and Induced Tensile Stress Characteristics of Mortar and Concrete under Restrained Shrinkage,” ASTM International, West Conshohocken, PA, 2018. [Online]. Available: <https://compass.astm.org/download/C1581C1581M.6241.pdf>.
- [31] AASHTO T 334, “Standard Method of Test for Estimating the Cracking Tendency of Concrete,” American Association of State Highway and Transportation Officials, Washington, DC, 2020.
- [32] AASHTO T 363, “Standard Method of Test for Evaluating Stress Development and Cracking Potential due to Restrained Volume Change Using a Dual Ring Test,” American Association of State Highway and Transportation Officials, Washington, DC, 2017.
- [33] R. Springenschmid, R. Breitenbucher, and M. Mangold, “Development of the cracking frame and the temperature-stress testing machine,” in *Thermal Cracking in Concrete at Early Ages: Proceedings of the International RILEM Symposium*, London: CRC Press, 1995, pp. 138–144.
- [34] A. Schindler, B. Byard, and A. Tankasala, “Mitigation of early-age cracking in concrete structures,” *MATEC Web Conf.*, vol. 284, p. 07005, 2019, doi: 10.1051/mateconf/201928407005.
- [35] Nordtest, “Concrete: Cracking tendency – exposure to drying during the first 24 hours (NT BUILD 433),” Finland, May 1995. [Online]. Available:

- <http://www.nordtest.info/wp/1995/05/22/concrete-cracking-tendency-exposure-to-drying-during-the-first-24-hours-nt-build-433/>.
- [36] ASTM C1579, “Standard Test Method for Evaluating Plastic Shrinkage Cracking of Restrained Fiber Reinforced Concrete (Using a Steel Form Insert),” ASTM International, West Conshohocken, PA, 2013.
 - [37] ASTM C1157, “Standard Performance Specification for Hydraulic Cement,” ASTM International, West Conshohocken, PA, 2017.
 - [38] AASHTO T 160, “Standard Method of Test for Length Change of Hardened Hydraulic Cement Mortar and Concrete,” American Association of State Highway and Transportation Officials, Washington, DC, 2017.
 - [39] ASTM C157, “Standard Test Method for Length Change of Hardened Hydraulic-Cement Mortar and Concrete,” ASTM International, West Conshohocken, PA, 1975.
 - [40] EN 12390 - 16, “Testing Hardened Concrete - Determination of the Shrinkage of Concrete.” CEN European Committee for Standardization, 2019.
 - [41] AASHTO T 336-15, “Standard Method of Test for Coefficient of Thermal Expansion of Hydraulic Cement Concrete,” American Association of State Highway and Transportation Officials, Washington, DC, 2019.
 - [42] ASTM C827, “Standard Test Method for Change in Height at Early Ages of Cylindrical Specimens of Cementitious Mixtures,” ASTM International, West Conshohocken, PA, 2016.
 - [43] P. H. Emmons and A. M. Vaysburd, “Performance Criteria for Concrete Repair Materials. Phase 1.,” STRUCTURAL PRESERVATION SYSTEMS INC BALTIMORE MD, 1995.
 - [44] R. W. Poston, K. E. Kesner, P. H. Emmons, and A. M. Vaysburd, “Performance Criteria for Concrete Repair Materials, Phase II Laboratory Results,” Structural Preservation Systems, Inc., 1998.
 - [45] ASTM C596, “Standard Test Method for Drying Shrinkage of Mortar Containing Hydraulic Cement,” ASTM International, West Conshohocken, PA, 2018.
 - [46] ASTM C1090, “Standard Test Method for Measuring Changes in Height of Cylindrical Specimens of Hydraulic-Cement Grout,” ASTM International, West Conshohocken, PA, 2015.
 - [47] ACI Committee 201, “Guide to Durable Concrete,” American Concrete Institute, 2016.
 - [48] N. Hearn, R. D. Hooton, and M. Nokken, “Pore Structure, Permeability, and Penetration Resistance Characteristics of Concrete - Knovel.” ASTM International. ASTM 169D: Significance of tests and properties of concrete and concrete-making materials, 2006, Accessed: Nov. 05, 2019. [Online].
 - [49] K. D. Stanish, R. D. Hooton, and M. D. A. Thomas, “Testing the Chloride Penetration Resistance of Concrete: A Literature Review,” p. 33, 1997.
 - [50] J. B. Weiss and S. Shields-Cook, “Relating Transport Properties to Performance in Concrete Pavements,” 2014.
 - [51] D. Whiting, “Permeability of Selected Concretes,” *SP*, vol. 108, pp. 195–222, Aug. 1988, doi: 10.14359/2186.
 - [52] P. K. Mehta, “Durability of concrete in marine environment—A review,” *Special Publication*, vol. 65, pp. 1–20, 1980.

- [53] E. J. Garboczi, “Permeability, diffusivity, and microstructural parameters: A critical review,” *Cement and Concrete Research*, vol. 20, no. 4, pp. 591–601, Jul. 1990, doi: 10.1016/0008-8846(90)90101-3.
- [54] PCA, “Permeability of Concrete,” *Portland Cement Association*, Oct. 1988.
- [55] CCAA, “Chloride Resistance of Concrete,” *Cement Concrete & Aggregates Australia*, Sydney, Australia, Jun. 2009.
- [56] X. Li, Q. Xu, and S. Chen, “An experimental and numerical study on water permeability of concrete,” *Construction and Building Materials*, vol. 105, pp. 503–510, 2016, doi: <http://dx.doi.org/10.1016/j.conbuildmat.2015.12.184>.
- [57] L. O. Nilsson, E. Poulsen, P. Sandberg, Henrik Erndahl Sørensen, and O. Klinghoffer, “HETEK, Chloride penetration into concrete, State-of-the-Art. Transport processes, corrosion initiation, test methods and prediction models,” 1996.
- [58] B. A. Suprenant, “Designing concrete for exposure to seawater,” *Concrete Construction*, pp. 914–916, 1991.
- [59] ACI Committee 201, “Guide to Durable Concrete,” American Concrete Institute, ACI 201.2R-16, 2016.
- [60] ACI Committee 212, “Report on Chemical Admixtures for Concrete,” ACI International, 2016.
- [61] K. C. Hover, “Concrete mixture proportioning with water-reducing admixtures to enhance durability: a quantitative model,” *Cement and Concrete Composites*, vol. 20, no. 2–3, pp. 113–119, 1998.
- [62] A. Chini, L. Muszynski, and J. Hicks, “Determination of Acceptance Permeability Characteristics for Performance-Related Specifications for Portland Cement Concrete,” University of Florida, Gainesville, FL, Final Report BC 354-41, 2003.
- [63] C. Ozyildirim, “Effects of Temperature on the Development of Low Permeability in Concretes,” Virginia Transportation Research Council, VTRC 98-R14, 1998.
- [64] FDOT, “Standard Specifications for Road and Bridge Construction,” 2020.
- [65] A. Neville, “Chloride attack of reinforced concrete: an overview,” *Materials and Structures*, vol. 28, no. 2, pp. 63–70, 1995, doi: 10.1007/BF02473172.
- [66] J. M. Scanlon and M. R. Sherman, “Fly Ash Concrete: An Evaluation Of Chloride Penetration Testing Methods,” *CI*, vol. 18, no. 6, pp. 57–62, Jun. 1996.
- [67] E. Vivas, A. J. Boyd, H. Hamilton III, and M. Bergin, “Permeability of Concrete—Comparison of Conductivity and Diffusion Methods,” University of Florida, Gainesville, FL, Final report 00026899, 2007.
- [68] ASTM C1556, “Standard Test Method for Determining the Apparent Chloride Diffusion Coefficient of Cementitious Mixtures by Bulk Diffusion,” ASTM International, West Conshohocken, PA, 2011.
- [69] NT BUILD 443, “Concrete, Hardened: Accelerated Chloride Penetration,” Nordtest, 1995.
- [70] P. N. Balaguru, “Evaluation of corrosion inhibitors,” 2002.
- [71] ASTM G109, “Standard Test Method for Determining Effects of Chemical Admixtures on Corrosion of Embedded Steel Reinforcement in Concrete Exposed to Chloride Environments,” West Conshohocken, Pennsylvania, 2013.
- [72] UNE-EN ISO 9227, “Corrosion tests in artificial atmospheres - salt spray tests,” 2017.
- [73] K. V. Tittelboom, N. De Belie, and R. D. Hooton, “Test Methods for Resistance of Concrete to Sulfate Attack - A Critical Review,” in *Performance of Cement-Based*

- Materials in Aggressive Aqueous Environments State-of-the-Art Report, RILEM TC 211-PAE*, Springer, 2013, pp. 251–288.
- [74] ASTM C1012, “Standard Test Method for Length Change of Hydraulic-Cement Mortars Exposed to a Sulfate Solution,” ASTM International, West Conshohocken, PA, 2018.
- [75] ASTM C452, “Standard Test Method for Potential Expansion of Portland-Cement Mortars Exposed to Sulfate,” ASTM International, West Conshohocken, PA, 2019.
- [76] F. Aguayo, “External Sulfate Attack of Concrete: An Accelerated Test Method, Mechanisms, and Mitigation Techniques,” Doctor of Philosophy, University of Texas at Austin, 2016.
- [77] T. Drimalas, “Laboratory and field evaluations of external sulfate attack,” Doctor of Philosophy, University of Texas at Austin, 2007.
- [78] J. A. Hartell, A. J. Boyd, and C. C. Ferraro, “Sulfate attack on concrete: effect of partial immersion,” *Journal of Materials in Civil Engineering*, vol. 23, no. 5, pp. 572–579, 2010.
- [79] M. Santhanam, “Studies on Sulfate Attack: Mechanisms, Test Methods, and Modeling,” Doctor of Philosophy, Purdue University, 2001.
- [80] ASTM C1202, “Standard Test Method for Electrical Indication of Concrete’s Ability to Resist Chloride Ion Penetration,” ASTM International, West Conshohocken, PA, 2012.
- [81] AASHTO T 277, “Standard Method of Test for Electrical Indication of Concrete’s Ability to Resist Chloride Ion Penetration,” American Association of State Highway and Transportation Officials, Washington, DC, 2011.
- [82] ASTM C192, “Practice for Making and Curing Concrete Test Specimens in the Laboratory,” ASTM International, West Conshohocken, PA, 2019. doi: 10.1520/C0192_C0192M-18.
- [83] D. A. Whiting and M. A. Nagi, “Electrical Resistivity of Concrete - A Literature Review,” Portland Cement Association, Skokie, Illinois, 2457, 2003.
- [84] M. R. Nokken and R. D. Hooton, “Electrical Conductivity Testing,” *CI*, vol. 28, no. 10, pp. 58–63, Oct. 2006.
- [85] C. Ozyildirim, “Rapid Chloride Permeability Testing of Silica-Fume Concrete,” *Cement, Concrete and Aggregates*, vol. 16, no. 1, pp. 53–56, 1994.
- [86] NT Build 492, “Chloride migration coefficient from non-steady-state migration experiments,” 1999.
- [87] AASHTO T 358, “Standard Method of Test for Surface Resistivity Indication of Concrete’s Ability to Resist Chloride Ion Penetration,” American Association of State Highway and Transportation Officials, Washington, DC, 2019.
- [88] R. J. Kessler, R. G. Powers, E. Vivas, M. A. Paredes, and Y. P. Virmani, “Surface Resistivity as an Indicator of Concrete Chloride Penetration Resistance,” presented at the Concrete Bridge Conference, St. Louis, Missouri, 2008, Accessed: Jan. 13, 2016. [Online].
- [89] R. Spragg, Y. Bu, K. Snyder, D. Bentz, and J. Weiss, “Electrical Testing of Cement-Based Materials: Role of Testing Techniques, Sample Conditioning, and Accelerated Curing,” *JTRP Technical Reports*, Nov. 2013, doi: 10.5703/1288284315230.
- [90] W. Morris, E. I. Moreno, and A. A. Sagüés, “Practical evaluation of resistivity of concrete in test cylinders using a Wenner array probe,” *Cement and Concrete Research*, vol. 26, no. 12, pp. 1779–1787, Dec. 1996, doi: 10.1016/S0008-8846(96)00175-5.

- [91] R. Spragg, C. Villani, K. Snyder, D. Bentz, J. W. Bullard, and J. Weiss, “Factors That Influence Electrical Resistivity Measurements in Cementitious Systems,” *Journal of the Transportation Research Board*, pp. 90–98, Nov. 2013, doi: 10.3141/2342-11.
- [92] R. Spragg, J. Castro, T. Nantung, M. Paredes, and J. Weiss, “Variability Analysis of the Bulk Resistivity Measured Using Concrete Cylinders,” *JTRP Technical Reports*, Jan. 2011, doi: 10.5703/1288284314646.
- [93] M. D. Newlands, M. R. Jones, S. Kandasami, and T. A. Harrison, “Sensitivity of electrode contact solutions and contact pressure in assessing electrical resistivity of concrete,” *Mater Struct*, vol. 41, no. 4, pp. 621–632, Jun. 2007, doi: 10.1617/s11527-007-9257-6.
- [94] R. B. Polder, “Test methods for on site measurement of resistivity of concrete — a RILEM TC-154 technical recommendation,” *Construction and Building Materials*, vol. 15, no. 2–3, pp. 125–131, Mar. 2001, doi: 10.1016/S0950-0618(00)00061-1.
- [95] AASHTO TP 119, “Standard Method of Test for Electrical Resistivity of a Concrete Cylinder Tested in a Uniaxial Resistance Test,” American Association of State Highway and Transportation Officials, Washington, DC, 2015.
- [96] P. Ghosh and Q. Tran, “Correlation Between Bulk and Surface Resistivity of Concrete,” *International Journal of Concrete Structures and Materials*, vol. 9, no. 1, pp. 119–132, Nov. 2014, doi: 10.1007/s40069-014-0094-z.
- [97] M. D. A. Thomas, R. D. Hooton, A. Scott, and H. Zibara, “The effect of supplementary cementitious materials on chloride binding in hardened cement paste,” *Cement and Concrete Research*, vol. 42, no. 1, pp. 1–7, Jan. 2012, doi: 10.1016/j.cemconres.2011.01.001.
- [98] O. B. Isgor and W. J. Weiss, “A nearly self-sufficient framework for modelling reactive-transport processes in concrete,” *Materials and structures*, vol. 52, no. 1, pp. 1–17, 2019.
- [99] A. Farahani, H. Taghaddos, and M. Shekarchi, “Prediction of long-term chloride diffusion in silica fume concrete in a marine environment,” *Cement and Concrete Composites*, vol. 59, pp. 10–17, May 2015, doi: 10.1016/j.cemconcomp.2015.03.006.
- [100] R. Loser, B. Lothenbach, A. Leemann, and M. Tuchschnid, “Chloride resistance of concrete and its binding capacity—Comparison between experimental results and thermodynamic modeling,” *Cement and Concrete Composites*, vol. 32, no. 1, pp. 34–42, 2010.
- [101] A. Ipavec, T. Vuk, R. Gabrovšek, and V. Kaučič, “Chloride binding into hydrated blended cements: The influence of limestone and alkalinity,” *Cement and Concrete Research*, vol. 48, pp. 74–85, 2013.
- [102] T. Cheewaket, C. Jaturapitakkul, and W. Chalee, “Long term performance of chloride binding capacity in fly ash concrete in a marine environment,” *Construction and Building Materials*, vol. 24, no. 8, pp. 1352–1357, 2010.
- [103] R. Dhir and M. Jones, “Development of chloride-resisting concrete using fly ash,” *fuel*, vol. 78, no. 2, pp. 137–142, 1999.
- [104] USBR 4908-92, “Procedure for Length Change of Hardened Concrete Exposed to Alkali Sulfates,” U.S. Department of the Interior Bureau of Reclamation, 1992.
- [105] D. Mulenga, J. Stark, and P. Nobst, “Praxisnahes Prüfverfahren zum Sulfatwiderstand von Beton und Mörtel mit und ohne Flugasche,” *Beiträge zum DafStb-Forschungskolloquium*, vol. 37, pp. 197–207, 1999.

- [106] D. M. Mulenga, *Zum Sulfatangriff auf Beton und Mörtel einschließlich der Thaumazitbildung*. dissertation. de, 2002.
- [107] M. Alexander, A. Bertron, N. De Belie, and others, *Performance of cement-based materials in aggressive aqueous environments*, vol. 10. Springer, 2013.
- [108] I. R. de Almeida, “Resistance of High Strength Concrete to Sulfate Attack: Soaking and Drying Test,” *SP*, vol. 126, pp. 1073–1092, Aug. 1991, doi: 10.14359/2498.
- [109] P. J. Tumidajski and I. Turc, “A rapid test for sulfate ingress into concrete,” *Cement and concrete research*, vol. 25, no. 5, pp. 924–928, 1995.
- [110] Y.-S. Park, J.-K. Suh, J.-H. Lee, and Y.-S. Shin, “Strength deterioration of high strength concrete in sulfate environment,” *Cement and Concrete Research*, vol. 29, no. 9, pp. 1397–1402, Sep. 1999, doi: 10.1016/S0008-8846(99)00106-4.
- [111] Engineering ToolBox, “Density of aqueous solutions of inorganic sodium salts,” 2017. https://www.engineeringtoolbox.com/density-aqueous-solution-inorganic-sodium-salt-concentration-d_1957.html.
- [112] Engineering ToolBox, “Density of aqueous solutions of some inorganic substances,” 2017. https://www.engineeringtoolbox.com/density-aqueous-solution-inorganic-salt-acid-concentration-d_1958.html.
- [113] AASHTO PP 84, “Standard Practice for Developing Performance Engineered Concrete Pavement Mixtures,” American Association of State Highway and Transportation Officials, Washington, DC, 2020.
- [114] W. J. Weiss, T. Ley, O. B. Isgor, and T. Van Dam, “Toward performance specifications for concrete durability: Using the formation factor for corrosion and critical saturation for freeze-thaw,” *Proceedings of the 96th Annual Transportation Research Board, Washington, DC, USA*, pp. 8–12, 2017.
- [115] M. R. Nokken and R. D. Hooton, “Using pore parameters to estimate permeability or conductivity of concrete,” *Mater Struct*, vol. 41, no. 1, pp. 1–16, Jan. 2007, doi: 10.1617/s11527-006-9212-y.
- [116] J. M. Armaghani and D. G. Bloomquist, “Development of concrete durability specification and ratings in Florida,” *Transportation Research Record*, no. 1458, 1994.
- [117] P. Soongswang, M. Tia, D. G. Bloomquist, C. Meletiou, and L. M. Sessions, “Efficient Test Setup For Determining The Water-Permeability Of Concrete,” *Transportation Research Record*, no. 1204, 1988, Accessed: Dec. 07, 2018. [Online]. Available: <https://trid.trb.org/view/302190>.
- [118] EN 12390-8, “Depth of penetration of water under pressure,” 2019.
- [119] C. M. Tibbetts, J. M. Paris, C. C. Ferraro, K. A. Riding, and T. G. Townsend, “Relating water permeability to electrical resistivity and chloride penetrability of concrete containing different supplementary cementitious materials,” *Cement and Concrete Composites*, vol. 107, 2020, doi: 10.1016/j.cemconcomp.2019.103491.
- [120] CRD-C 48-92, “Standard Test Method for Water Permeability of Concrete,” 1992.
- [121] ACCI, “Water permeability test.”
- [122] CRD-C 48-73, “Method of test for water permeability of concrete,” 1973.
- [123] L. H. McCurrich, “Permeability Testing of Site Concrete. A Review of Methods And Experience,” *Concrete Society Technical Report*, no. 31, 1987.
- [124] R. D. Hooton, “What Is Needed In A Permeability Test For Evaluation Of Concrete Quality.,” *MRS Online Proceedings Library Archive*, vol. 137, 1988.

- [125] R. P. Khatri and V. Sirivivatnanon, “Methods for the determination of water permeability of concrete,” *Materials Journal*, vol. 94, no. 3, pp. 257–261, 1997.
- [126] S. Zhutovsky and R. D. Hooton, “Role of sample conditioning in water absorption tests,” *Construction and Building Materials*, vol. 215, pp. 918–924, 2019.
- [127] ASTM C1585, “Standard Test Method for Measurement of Rate of Absorption of Water by Hydraulic-Cement Concretes,” ASTM International, West Conshohocken, Pennsylvania, 2013.
- [128] J. Castro, D. Bentz, and J. Weiss, “Effect of sample conditioning on the water absorption of concrete,” *Cement and Concrete Composites*, vol. 33, no. 8, pp. 805–813, 2011.
- [129] W. Li, M. Pour-Ghaz, J. Castro, and J. Weiss, “Water absorption and critical degree of saturation relating to freeze-thaw damage in concrete pavement joints,” *Journal of Materials in Civil Engineering*, vol. 24, no. 3, pp. 299–307, 2012.
- [130] ASTM C642, “Standard Test Method for Density, Absorption, and Voids in Hardened Concrete,” ASTM International, West Conshohocken, PA, 2013.