

Evaluating Transportation Systems Management & Operations (TSM&O) Benefits to Alternative Intersection Treatments



**FLORIDA DEPARTMENT OF TRANSPORTATION
FDOT Contract BDV24-977-09**

FINAL REPORT

Submitted to:

Research.Center@dot.state.fl.us

Business Systems Coordinator, (850) 414-4614
Florida Department of Transportation Research Center
605 Suwannee Street, MS30
Tallahassee, FL 32399

c/o John Moore

FDOT District 5 – Project Manager

Submitted by:

**Dr. Hatem Abou-Senna, P.E. (PI), habousenna@ucf.edu
Dr. Essam Radwan, P.E. (Co-PI), Ahmed.Radwan@ucf.edu
Sebastian Tabares, Jiawei Wu, & Sandesh Chalise**



Center for Advanced Transportation Systems Simulation (CATSS)
Department of Civil, Environmental & Construction Engineering (CECE)
University of Central Florida
Orlando, FL 32816-2450
(407) 823-4738

December 2015

DISCLAIMER

The opinions, findings, and conclusions expressed in this publication are those of the authors and not necessarily those of the State of Florida Department of Transportation.

CONVERSION FACTORS

APPROXIMATE CONVERSIONS TO SI UNITS

SYMBOL	WHEN YOU KNOW	MULTIPLY BY	TO FIND	SYMBOL
LENGTH				
in	inches	25.4	millimeters	mm
ft	feet	0.305	meters	m
yd	yards	0.914	meters	m
mi	miles	1.61	kilometers	km
AREA				
in²	square inches	645.2	square millimeters	mm ²
ft²	square feet	0.093	square meters	m ²
yd²	square yard	0.836	square meters	m ²
ac	acres	0.405	hectares	ha
mi²	square miles	2.59	square kilometers	km ²
VOLUME				
fl oz	fluid ounces	29.57	milliliters	mL
gal	gallons	3.785	liters	L
ft³	cubic feet	0.028	cubic meters	m ³
yd³	cubic yards	0.765	cubic meters	m ³
NOTE: volumes greater than 1000 L shall be shown in m ³				
MASS				
oz	ounces	28.35	grams	g
lb	pounds	0.454	kilograms	kg
T	short tons (2000 lb)	0.907	Mega grams (or "metric ton")	Mg (or "t")

*SI is the symbol for the International System of Units. Appropriate rounding should be made to comply with Section 4 of ASTM E380. (Revised March 2003)

TECHNICAL REPORT DOCUMENTATION PAGE

1. Report No.	2. Government Accession No.	3. Recipient's Catalog No.	
4. Title and Subtitle Evaluating Transportation Systems Management & Operations (TSM&O) Benefits to Alternative Intersection Treatments		5. Report Date December 2015	
		6. Performing Organization Code	
7. Author(s) Hatem Abou-Senna, Essam Radwan, Sebastian Tabares, Jiawei Wu, & Sandesh Chalise		8. Performing Organization Report No.	
9. Performing Organization Name and Address Center for Advanced Transportation Systems Simulation (CATSS) Department of Civil, Environmental & Construction Engineering University of Central Florida 4000 Central Florida Blvd. Orlando, FL 32816-2450 (407) 823-4738		10. Work Unit No. (TRAIS)	
		11. Contract or Grant No. BDV24-977-09	
12. Sponsoring Agency Name and Address Florida Department of Transportation Research Center 605 Suwannee Street, MS 30 Tallahassee, FL 32399 (850) 414-4615		13. Type of Report and Period Covered Final Report (May 2014 – Dec 2015)	
		14. Sponsoring Agency Code	
15. Supplementary Notes			
16. Abstract This research provides a comprehensive review and assessment of current 'alternative intersection' methods which successfully eliminate the left-turn phase. With increasing traffic and limited resources, the Florida Department of Transportation moves forward with a vision of optimizing intersection control through the implementation of innovative intersection designs through the Transportation Systems Management & Operations (TSM&O) program. Because of the specific interest in the integration of alternative intersection treatments within the State of Florida, this research assessed the operational benefits, challenges, evaluated the safety implications for bicycles and pedestrians through the alternative intersection methods, and quantified driver confusion opportunities, maintenance impacts, and comparative cost control measures for benefit-to-cost ratio development. The operational analysis is based on several case studies presented along with the advantages and disadvantages of each alternative. The overall analysis provided a variety of parameters that need to be considered when implementing any of these designs. These intersections can be significantly cumbersome for vehicles, bicyclists, and pedestrians to navigate without proper implementation of wayfinding signs and education of the road users. However, when applied properly, the benefits of these designs can save municipalities years of capacity and preserve the existing infrastructure for a longer period of time. These goals align with the overall goal of the FDOT TSM&O program.			
17. Key Word Transportation Systems Management & Operations (TSM&O), Alternative Intersections, Intersection Treatments, CFI, DDI, MUT		18. Distribution Statement	
19. Security Classif. (of this report)	20. Security Classif. (of this page)	21. No. of Pages 191	22. Price

ACKNOWLEDGEMENT

The authors would like to express their sincere appreciation to the Florida Department of Transportation (Central Office) and acknowledge the cooperation and support of Mr. John Moore (District 5) for serving as the Project Manager and providing guidance during the course of this research.

EXECUTIVE SUMMARY

This report presents a comprehensive review and assessment of current ‘alternative intersection’ methods which successfully eliminate the left-turn phase. The left-turn phase can reduce intersection efficiency considerably. With increasing traffic and limited resources, the Department of Transportation moves forward with a vision of optimizing intersection control through the implementation of innovative intersection designs through the Transportation Systems Management & Operations (TSM&O) program.

TSM&O is an established program used to enhance the performance of multimodal infrastructures. The purpose of this program is to improve safety as well as capacity, reduce congestion and delay, and improve the travel time reliability along all modes of transportation. This project assessed the operational benefits and challenges. In addition, considerations were made for the evaluation of safety for bicycles and pedestrians utilizing these alternative intersections. The TSM&O program has over dozen strategies that aim at improving travel time reliability and reducing delays. The main objective of this research was to evaluate the benefits of six different alternative intersection treatments and develop an evaluation matrix for the design criteria and placement of the following alternative treatments:

- Continuous Flow Intersection (CFI)
- Diverging Diamond Interchange (DDI)
- Median U-Turn (MUT)
- Restricted Crossing U-Turn (RCUT)
- Quadrant Roadway Intersection (QRI)
- Roundabouts

Operational analysis and studies presented regarding these alternative designs proved that they outperform most conventional intersections and enhance the arterial flow of traffic. Although there is not much field data available for some of these new designs, micro-simulation analyses showed that they are effective at improving safety and efficiency, which are usually two conflicting goals.

The analysis highlighted several important aspects regarding CFI traffic operations in the case of unbalanced volumes and demonstrated how partial CFI intersections can improve the overall intersection performance at various demands. The CFI also proved to outperform the conventional intersection. It is crucial to consider critical movements in the CFI design; this is where the most operational benefit lies. The analysis also showed that significant throughput improvements were observed at high volume levels, with 25 percent increase in capacity.

The MUT intersection operations showed an improvement in the performance when compared to the existing condition. The design significantly reduced the number of conflicts at the main intersection. The two-phase signal timing plan provided higher percentage of green time for each of the through movements. However, the left-turn movements are susceptible higher delay and travel time due to their indirect movement through the U-turn crossover. Wayfinding is very important at MUT intersections, especially for left-turning drivers who are not familiar with the

intersection. The MUT design outperformed the conventional intersection in terms of delay and travel time for increased volume level as well.

The analysis also demonstrated how RCUT can improve the overall performance compared to the existing conditions. The RCUT intersection reroutes the through and left-turn movements from the minor streets to the median U-turn crossover, providing an easier maneuver at the major street. The intersection design significantly reduces the number of conflicts at the main intersection. Only two phases are required at the main intersection to accommodate the vehicles and pedestrians, which ensures a better operation at the major street. However, the tradeoff is that the movements on the minor road may exhibit higher delay and travel time due to their indirect movement using U-turn crossover. Vehicle-pedestrian conflicts are reduced significantly using a “Z” shaped crossing in RCUT intersection. The case study showed that RCUT intersection reduced the overall delay and travel time, and improved the level of service compared to a conventional intersection.

The DDI traffic operations analysis showed that it is best suited for conventional diamond interchanges with heavy left-turn volumes as well as unbalanced volumes. It also demonstrated how DDI can improve the overall performance compared to a CDI. Based on the DDI conflict analysis, traffic safety was improved significantly due to the reduction in the number of vehicle-to-vehicle conflicts. DDI also reduced the delay of all left-turn movements and improved the overall level of service for both approaches of the crossover intersections.

QRIs are applicable mainly at intersections with busy arterials. The design approach reroutes all four left-turn movements in the four-legged intersection using a secondary roadway. The elimination of the left-turn lanes at the main intersection provides a shorter crossing distance for pedestrians and bicyclists. The case study showed that QRI intersection reduced the overall delay and travel time, and improved the level of service compared to the conventional intersection.

Alternative intersection treatments lower the number of conflicts at intersections and help reduce overall congestion. While these alternative designs are noticeably different from each other in approach, there is a common aspect among them. They attempt to remove one or more of the critical conflicting movements from the major intersection and divide the intersection into smaller networks that would operate in a one-way fashion. Thus having fewer signal phases with shorter signal cycle lengths, shorter delays, and higher capacities compared to conventional intersections. They have been successfully implemented in Utah, North Carolina, Missouri, and Louisiana.

The overall analysis provided a variety of parameters that need to be considered when implementing any of these designs. These intersections can be significantly cumbersome for vehicles, bicyclists, and pedestrians to navigate without the proper implementation of wayfinding signs and education of the road users. However, the benefits of these designs, when applied properly, can save municipalities years of capacity and preserve the existing infrastructure for a longer period of time. These goals align with the overall goal of the FDOT TSM&O program.

TABLE OF CONTENTS

DISCLAIMER	ii
CONVERSION FACTORS	iii
TECHNICAL REPORT DOCUMENTATION PAGE	iv
ACKNOWLEDGEMENT	v
EXECUTIVE SUMMARY	vi
LIST OF FIGURES	xiv
LIST OF TABLES	xvii
I- EVALUATION OF NATIONAL, STATE, AND LOCAL INTERSECTION TREATMENTS	1
1.1 Introduction	1
1.2 Crossover Displaced Left-Turn (XDL)	4
1.2.1 Introduction	4
1.2.2 Operation	4
1.2.3 Analysis	5
1.2.4 Performance Measures	5
1.2.5 Further Studies and Reports	7
1.2.6 Best Practices.....	10
1.3 Diverging Diamond Interchange (DDI)	11
1.3.1 Introduction	11
1.3.2 Operation	11
1.3.3 Analysis	12
1.3.4 Performance Measures	13
1.3.5 Further Studies and Reports	14
1.3.6 Best Practices.....	16
1.4 Double Crossover Intersection (DXI)	18
1.4.1 Introduction	18
1.4.2 Operation	18
1.4.3 Analysis	19
1.4.4 Performance Measures	20
1.4.5 Further Studies and Reports	21

1.4.6 Best Practices.....	21
1.5 Median U-Turn (MUT)	22
1.5.1 Introduction	22
1.5.2 Operation	22
1.5.3 Analysis	24
1.5.4 Performance Measures	24
1.5.5 Further Studies and Reports	24
1.5.6 Best Practices.....	28
1.6 Restricted Crossing U-Turn (RCUT)	30
1.6.1 Introduction	30
1.6.2 Operation	30
1.6.3 Analysis	31
1.6.4 Performance Measures	31
1.6.5 Further Studies and Reports	32
1.6.6 Other Considerations	33
1.6.7 Best Practices.....	33
1.7 Quadrant Roadway Intersection (QRI)	35
1.7.1 Introduction	35
1.7.2 Operation	35
1.7.3 Analysis	37
1.7.4 Performance Measures	38
1.7.5 Further Studies and Reports	39
1.7.6 Best Practices.....	40
1.8 Roundabouts.....	41
1.8.1 Introduction	41
1.8.2 Operation	41
1.8.3 Analysis	41
1.8.4 Performance Measures	42
1.8.5 Further Studies and Reports	42
1.8.6 Best Practices.....	45

II- DEVELOPMENT OF PERFORMANCE MEASURES AND EVALUATION MATRIX
..... 46

2.1 Continuous Flow Intersections (CFI)..... 46

- 2.1.1 Area Type and Roadway Conditions..... 46
- 2.1.2 Right of Way 46
- 2.1.3 Pedestrian and Bicyclist Interaction 49
- 2.1.4 Wayfinding 51
- 2.1.5 Signalization 52
- 2.1.6 Benefit-to-Cost Ratio..... 54
- 2.1.7 Performance Measures 55

2.2 Median U-Turn (MUT) 56

- 2.2.1 Area Type and Roadway Conditions..... 56
- 2.2.2 Right of Way 56
- 2.2.3 Pedestrian and Bicyclist Interaction 57
- 2.2.4 Wayfinding 59
- 2.2.5 Signalization 61
- 2.2.6 Benefit-to-Cost Ratio..... 62
- 2.2.7 Performance Measures 63

2.3 Restricted Crossing U-Turn 64

- 2.3.1 Area Type and Roadway Conditions..... 64
- 2.3.2 Right of Way 66
- 2.3.3 Pedestrian and Bicyclist Interaction 68
- 2.3.4 Wayfinding 69
- 2.3.5 Signalization 71
- 2.3.6 Benefit-to-Cost Ratio..... 72
- 2.3.7 Performance Measures 73

2.4 Diverging Diamond Interchange (DDI) 74

- 2.4.1 Area Type and Roadway Conditions..... 74
- 2.4.2 Right of Way 75
- 2.4.3 Pedestrian and Bicyclist Interaction 76
- 2.4.4 Wayfinding 78

2.4.5 Signalization	79
2.4.6 Benefit-to-Cost Ratio.....	80
2.4.7 Performance Measures	81
2.5 Roundabouts.....	82
2.5.1 Area Type and Roadway Conditions.....	82
2.5.2 Right of Way	83
2.5.3 Pedestrian and Bicyclist Interaction	84
2.5.4 Wayfinding.....	85
2.5.5 Signalization	86
2.5.6 Benefit-to-Cost Ratio.....	86
2.5.7 Performance Measures	87
2.6 Quadrant Roadway Intersections (QRI).....	88
2.6.1 Area Type and Roadway Conditions.....	88
2.6.2 Right of Way	89
2.6.3 Pedestrian and Bicyclist Interaction	89
2.6.4 Wayfinding.....	90
2.6.5 Signalization	91
2.6.6 Benefit-to-Cost Ratio.....	92
2.6.7 Performance Measures	93
2.7 Evaluation Matrix for Design Criteria of Alternative Intersection Designs	94
III- PILOT PROJECT ASSESSMENT	98
3.1 Continuous Flow Intersection (CFI)	98
3.1.1 Study Intersection and Roadway Conditions.....	98
3.1.2 Right of Way	99
3.1.3 Pedestrian and Bicyclist Interaction	101
3.1.4 Wayfinding.....	102
3.1.5 Signalization	103
3.1.6 Operational Performance.....	104
3.1.7 Benefit to Time Saving.....	113
3.1.8 Conclusions	114
3.2 Median U-Turn (MUT).....	115

3.2.1 Study Intersection and Roadway Conditions.....	115
3.2.2 Right of Way	116
3.2.3 Pedestrian and Bicyclist Interaction	117
3.2.4 Wayfinding	119
3.2.5 Signalization	120
3.2.6 Operational Performance	121
3.2.7 Benefit to Time Saving.....	126
3.2.8 Conclusion	127
3.3 Restricted Crossing U-Turn Intersection.....	128
3.3.1 Study Intersection and Roadway Conditions.....	128
3.3.2 Right of Way	129
3.3.3 Pedestrian and Bicycle Interaction	130
3.3.4 Wayfinding	133
3.3.5 Signalization	134
3.3.6 Operational Performance	135
3.3.7 Benefit to Time Saving.....	141
3.3.8 Conclusion	141
3.3.9 MUT versus RCUT Intersection.....	142
3.4 Diverging Diamond Interchange (DDI)	145
3.4.1 DDI Overview and Study Area	145
3.4.2 Right of Way	146
3.4.3 Pedestrian and Bicyclist Interaction	147
3.4.4 Wayfinding	149
3.4.5 Signalization	150
3.4.6 Traffic Evaluation.....	151
3.4.7 Benefit to Time Saving.....	157
3.4.8 Conclusion	158
3.5 Quadrant Roadway Intersection (QRI)	159
3.5.1 QRI Overview and Study Area.....	159
3.5.2 Right of Way	160
3.5.3 Pedestrian and Bicyclist Interaction	161

3.5.4 Wayfinding	162
3.5.5 Signalization	163
3.5.6 Operational Performance	164
3.5.7 Benefit to Time Saving	169
3.5.8 Conclusion	170
IV- CONCLUSIONS	171
REFERENCES.....	172

LIST OF FIGURES

Figure 1: Partial XDL Intersection on Eastbound and Westbound Approaches	5
Figure 2: XDL Design and Operation.....	6
Figure 3: DDI Design.....	11
Figure 4: 3D Model in VISSIM for DDI	12
Figure 5: Crossover Movement in a DDI	16
Figure 6: Design of Double Crossover Intersection (DXI).....	18
Figure 7: U-Turn Movements at MUT	23
Figure 8: Design of a Median U-Turn (MUT).....	23
Figure 9: Channelization for Left Turns at RCUT.....	30
Figure 10: Pedestrian Movements at an RCUT Intersection	32
Figure 11: Movements in a QRI	35
Figure 12: QRI Design.....	36
Figure 13: Single Lane Roundabout with Priority Movements	41
Figure 14: Typical Full CFI Intersection	48
Figure 15: Typical Footprint for CFI Intersection	49
Figure 16: Typical Pedestrian Movements at CFI Intersection	50
Figure 17: CFI Signing and Marking (Maryland Practice).....	52
Figure 18: Typical CFI Signal Locations.....	53
Figure 19: Typical 2-Phase Signal Operating Plans at CFI	54
Figure 20: Typical MUT Intersection Design.....	56
Figure 21: Loon Implementation at a MUT Intersection.....	57
Figure 22: Pedestrian Movements at a MUT Intersection	58
Figure 23: Typical Signing Plan for a MUT Intersection	60
Figure 24: Typical MUT Intersection Signal Location.....	61
Figure 25: Typical Signal Operating Plan at MUT.....	62
Figure 26: Typical RCUT Intersection	65
Figure 27: Typical Footprint for an RCUT Intersection.....	67
Figure 28: Typical Loon at an RCUT Crossover.....	67
Figure 29: Pedestrian “Z” Movement at an RCUT Intersection.....	68
Figure 30: Bicyclist Passing Across a Channelized Island at an RCUT.....	69
Figure 31: Typical Signing for RCUT Intersection	70
Figure 32: Signal Location at RCUT Intersection	71
Figure 33: Typical Signal Operating Plan for RCUT	72
Figure 34: Typical Full DDI Plan View	74
Figure 35: Typical Footprint for DDI.....	76
Figure 36: Pedestrian Movement at DDI.....	78
Figure 37: Signing and Marking Plan for DDI (Missouri)	79
Figure 38: Typical Signal Operating Plan for DDI.....	80
Figure 39: Typical Geometry of a Single Lane Roundabout.....	82
Figure 40: Typical Footprint of a Roundabout	83
Figure 41: Pedestrian and Bicycle Treatment at Roundabouts.....	85

Figure 42: Typical Signing Plan for an Urban Roundabout	86
Figure 43: Typical QRI with Four-Lane Connecting Roadway	88
Figure 44: Left-Turn Movement at a QRI	89
Figure 45: Crosswalks at a QRI.....	90
Figure 46: Typical Signing Plan for QRI.....	91
Figure 47: Typical Signal Operating Plan for QRI.....	92
Figure 48: Typical Signal Locations at QRI.....	92
Figure 49: Study Intersection – Osceola Parkway at US 441 (Orlando, FL)	99
Figure 50: Full CFI Intersection on All Approaches	100
Figure 51: Partial CFI Intersection on East and West Approaches	100
Figure 52: Typical Pedestrian Movements at CFI Intersection	102
Figure 53: CFI Signing and Marking (Maryland Practice).....	103
Figure 54: Typical 2-Phase Signal Operating Plans at CFI	104
Figure 55: Aggregate Delay Calculation at CFI (UDOT CFI Guidelines 2013).....	107
Figure 56: Volume Level versus Hourly Throughput by Intersection Type	111
Figure 57: Volume Level versus Delay by Intersection Type	112
Figure 58: V/C Ratio versus Delay per Vehicle by Intersection Type	112
Figure 59: Study Intersection (US 27 and Hartwood March Road)	115
Figure 60: MUT Intersection Coded in VISSIM	116
Figure 61: Conflict Points for Conventional and MUT Intersection	117
Figure 62: Single versus Two-Stage Pedestrian Crossing	118
Figure 63: Left-Turn Options for Bicycles	119
Figure 64: Example of Signing Plan for the MUT intersection.....	120
Figure 65: Typical MUT Intersection Signal Location.....	121
Figure 66: VISSIM Model for Conventional and MUT Intersection	122
Figure 67: Volume Level versus Hourly Throughput between CI and MUT Intersection.....	124
Figure 68: Volume Level versus Delay per Vehicle between CI and MUT.....	124
Figure 69: Study Intersection (US 27 and Hartwood March Road)	128
Figure 70: RCUT Intersection Coded in VISSIM	129
Figure 71: Vehicle-Pedestrian Conflict Points at a RCUT Intersection	131
Figure 72: Pedestrian Crossing at a RCUT Intersection.....	131
Figure 73: Minor Street Through Option for Bicycles	133
Figure 74: Typical Signing for RCUT Intersection	134
Figure 75: Signal Location at RCUT Intersection	135
Figure 76: VISSIM Model for Conventional and RCUT Intersection	136
Figure 77: Volume Level versus Hourly Throughput between CI and RCUT Intersection.....	138
Figure 78: Volume Level versus Delay per vehicle between CI and RCUT Intersection.....	138
Figure 79: Comparison of Overall Delay between RCUT and MUT for Volume Level	143
Figure 80: Delay by Movements Comparison between RCUT and MUT (100% Vol Level) ...	144
Figure 81: Delay by Movements Comparison between RCUT and MUT (200% Vol Level) ...	144
Figure 82: Conflict Points for Diamond Interchange and DDI Interchange.....	145
Figure 83: Study Interchange – SR 417 Ramps at Lake Nona Blvd	146
Figure 84: Anatomy of the DDI.....	147

Figure 85: DDI Pedestrian Navigation	148
Figure 86: DDI Signing	149
Figure 87: DDI Signal Phasing	151
Figure 88: DDI Signal Phasing Diagram	151
Figure 89: CDI and DDI VISSIM Model	153
Figure 90: Volume Level versus Hourly Throughput between CDI and DDI	155
Figure 91: Volume Level versus Delay between CDI and DDI	155
Figure 92: Study Intersection—Dean Road at University Boulevard (Orlando, FL)	160
Figure 93: QRI Design for Study Intersection	161
Figure 94: Crosswalks Locations at Study Intersection for QRI	162
Figure 95: Typical Signing Plan for QRI	163
Figure 96: Signal Location for QRI at Study Intersection	164
Figure 97: VISSIM Model for CI and QRI	165
Figure 98: Volume Level versus Hourly Throughput between CI and QRI	167
Figure 99: Volume Level versus Delay between CI and QRI	167

LIST OF TABLES

Table 1: Alternative Intersection Treatments Overview.....	2
Table 2: XDL versus Conventional Intersection Network Performance	9
Table 3: Turning Movement Volumes for Interchange	14
Table 4: DDI versus Conventional Interchange Comparisons	15
Table 5: DXI versus Conventional Intersection – Performance Results (without Peds).....	19
Table 6: Capacity of Conventional and DXI Designs	19
Table 7: DXI versus Conventional Intersection – Performance Results (with Peds).....	20
Table 8: MUT and Conventional Intersection Capacities.....	26
Table 9: Simulation Results (Hummer and Reid, 2000).....	27
Table 10: MUT Collision Rates from Michigan.....	28
Table 11: Comparisons between RCUT and Conventional Intersections	31
Table 12: System MOEs by Geometric Design.....	38
Table 13: Single Lane Roundabout – Comparison of VISSIM Results with Field Data	42
Table 14: Dual Lane Roundabout – Comparison of VISSIM Results with Field Data.....	42
Table 15: Before and after Crashes at Roundabouts.....	44
Table 16: Evaluation Matrix for Design Criteria of Alternative Intersection Designs.....	95
Table 17: Design of Experiment.....	105
Table 18: Performance Measures Comparison by Movement – Volume Level 100%	108
Table 19: Performance Measures Comparison by Movement – Volume Level 140%	108
Table 20: Overall Network Performance Measures Comparison.....	110
Table 21: CFI Benefit to Time Saving Compared to the Conventional Intersection.....	113
Table 22: Overall Network Performance Measures for CI and MUT	123
Table 23: Performance Measures Comparison by Movement — Volume Level 100%	125
Table 24: Performance Measures Comparison by Movement – Volume Level 200%	125
Table 25: Reduction of Cost by MUT by Saving Delay.....	126
Table 26: Overall Network Performance Comparison between CI and RCUT Intersection.....	137
Table 27: Performance Measures Comparison by Movement — Volume Level 100%	139
Table 28: Performance Measures Comparison by Movement—Volume Level 200%	140
Table 29: Reduction of Cost by RCUT by Saving Delay.....	141
Table 30: Overall Network Performance Comparison between MUT and RCUT Intersection.	142
Table 31: Overall Network Performance Measures for CDI and DDI.....	154
Table 32: Performance Measures Comparison by Movement — Volume Level 100%	156
Table 33: Performance Measures Comparison by Movement — Volume Level 300%	157
Table 34: DDI Benefit to Time Saving Compared to the Existing Interchange.....	158
Table 35: Overall Network Performance Measures for CI and QRI	166
Table 36: Performance Measures Comparison by Movement — Volume Level 100%	168
Table 37: Performance Measures Comparison by Movement — Volume Level 140%	168
Table 38: Reduction of Cost by QRI by Saving Delay.....	170



I- EVALUATION OF NATIONAL, STATE, AND LOCAL INTERSECTION TREATMENTS

1.1 Introduction

The following section provides a comprehensive review and assessment of current 'alternative intersection' methods that successfully eliminate the left-turn phase, which otherwise reduces intersection efficiency considerably. With increasing traffic and limited resources, the Department of Transportation moves forward with a vision of optimizing intersection control through the implementation of innovative intersection designs through the Transportation Systems Management & Operations (TSM&O) program. TSM&O is an established program used to enhance the performance of multimodal infrastructures. The purpose of this program is to improve safety as well as capacity, reduce congestions, delays and improve the travel time reliability along all modes of transportation. While there is specific interest in the integration of alternative intersection treatments within the State of Florida, this research would assess the operational benefits and challenges, evaluate the safety implications for bicycles and pedestrians through the alternative intersection methods, qualify driver confusion opportunities, maintenance impacts and comparative cost control measures for benefit-to-cost ratio development.

TSM&O has over a dozen strategies that aim at improving travel time reliability and reducing delays. However, this research focuses on arterial management. The main objective is to evaluate TSM&O benefits to the different alternative intersection treatments. Seven main alternative intersection treatments are included in this evaluation as follows; however, due to the similar operations of double crossover intersections and diverging diamond interchanges, the performance measures and case studies excluded the double crossover intersection alternative.

- 1- Continuous Flow Intersection
- 2- Diverging Diamond Interchange
- 3- Double Crossover Intersection
- 4- Median U-Turn
- 5- Restricted Crossing U-Turn
- 6- Quadrant Roadway Intersection
- 7- Roundabouts



Table 1: Alternative Intersection Treatments Overview







Treatments	Description	Advantages	Disadvantages
<p>Continuous Flow Intersection (CFI)/ Crossover Displaced Left Turn (XDL)</p> 	<p>The XDL intersection eliminates the conventional left turn by displacing the left turn lane onto the opposing side of the road.</p>	<ul style="list-style-type: none"> -Increase in capacity -Decrease in delays, number of stops, conflicts, queues, and emissions -Great for heavy left turns and thru traffic 	<ul style="list-style-type: none"> -Driver confusion -Needs proper signage & signals -Driveway access to adjacent businesses -Challenges for impaired pedestrians and requires multistage crossings -No U-turns
<p>Diverging Diamond Interchange (DDI)/ Double Crossover Diamond (DCD)</p> 	<p>The Eastbound and Westbound lanes cross over each other and allow the drivers to drive on the opposite side of the road.</p>	<ul style="list-style-type: none"> -Reduction of phases, conflicts, footprints, and construction cost -Increases safety & Capacity -Beneficial in heavy left & thru traffic 	<ul style="list-style-type: none"> -Lost time due to numerous phases -Driver Confusion -Concerns with access to adjacent parcels -Longer path for pedestrians
<p>Double Crossover Intersection (DXI)</p> 	<p>The DXI, in a similar way to DDI reroutes the flow of traffic before it reaches the intersection.</p>	<ul style="list-style-type: none"> -Reduction of phases, number of stops, average stop time, queues, and conflicts -Works best at high volumes 	<ul style="list-style-type: none"> -No significant benefit for low/medium volumes -Two additional signals are implemented -Pedestrian stops are longer
<p>Median U-Turn (MUT)</p> 	<p>The MUT removes the conventional left turn and forces drivers to make U-turns at designated crossovers to supplement left turns.</p>	<ul style="list-style-type: none"> -Reduced conflicts and construction costs -Vehicle stops reduction & travel time savings -Increase in throughput 30-45% -Safer approach 	<ul style="list-style-type: none"> -Longer average travel time for lefts -Higher stopping time for left turns -Requires wide medians -Pedestrians crosses wide median in two-stage manner

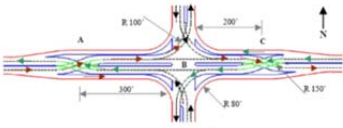
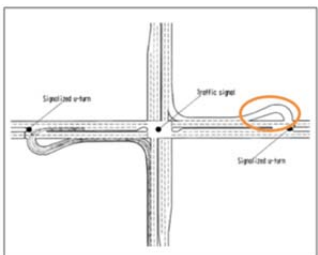

Table 1: Alternative Intersection Treatments Overview, continued

Treatment	Description	Advantages	Disadvantages
<p>Restricted Crossing U-Turn (RCUT)</p> 	<p>The RCUT is an alternative utilized to completely reroute left turn and thru traffic from minor roads to highways through U-turns</p>	<ul style="list-style-type: none"> -Low number of conflicts -Reduction of crash rate and severe crashes -Safer approach -Increase in throughput 	<ul style="list-style-type: none"> -Sometimes it causes longer travel times -Less efficient with heavy traffic on minor roads -Longer path for pedestrians & more exposure to traffic
<p>Quadrant Roadway Intersection (QRI)</p> 	<p>The QRI uses an additional roadway to eliminate direct left turns from the main intersection in one quadrant of the intersection.</p>	<ul style="list-style-type: none"> -Short average cycle length -Reduction in travel time, delays, queuing for thru traffic -Reduction in conflicts and pedestrian crossing times 	<ul style="list-style-type: none"> -Higher average speeds -Noncompliance of left turners -Additional signalization needed - Left turn travel distance is increased -Additional right of way for quadrant & extra cost for connecting roadway
<p>Roundabouts</p> 	<p>Roundabouts are circular roads that contain various openings/legs to enter the path.</p>	<ul style="list-style-type: none"> -Reduction in queues and delays -Reduction in number of conflict points and potentially less number of crashes and severe injuries 	<ul style="list-style-type: none"> - Roundabouts near operating capacity aren't efficient. - Adjusting the deflections and speed reductions can be difficult depending on the intersection geometry

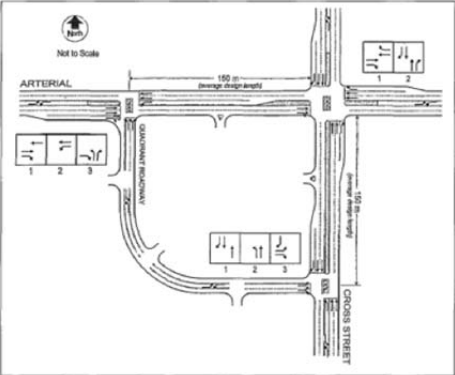

1.2 Crossover Displaced Left-Turn (XDL)

1.2.1 Introduction

The Crossover Displaced Left-Turn (XDL) concept is mainly utilized to alleviate the effect of left turns at intersections. This alternative is considered to resolve the issues caused by congestion and high traffic volumes and is best suited for intersections with moderate to high overall traffic volumes, especially those with very high or unbalanced left turn volumes. It can be a competitive alternative to grade separated interchange. In other regions, the XDL may also be known as the Continuous Flow Intersection (CFI). To avoid confusion, this alternative is referred to as the Crossover Displaced Left Turn (XDL) throughout this document. The XDL design is flexible and can support the needs for all modes of transportation including pedestrians and bicycles. However, provisions for walking and biking need to be considered throughout the project development process. It is worth noting that when XDLs are implemented at multiple intersections along corridors, travel times and throughput are improved. El-Esawey and Sayed (2008) studied the performance measures and signal optimization of the XDL and compared it to the conventional intersection. The study provided useful information on the operations, analyses as well as intersection characteristics of the XDL, as explained in the following sections.

1.2.2 Operation

The XDL intersection eliminates the conventional left turns at the main intersection by displacing the left turn lanes onto the opposing side of the road. The crossover occurs several hundred feet before reaching the main intersection. The vehicles wait on a signalized bay that eventually cross them over the opposing through lanes onto the left side of the road at a separate signalized intersection before the main intersection, sometimes referred to as secondary intersection. Both intersections are operating in a coordinated manner. At the main intersection, both the through and left turning traffic operate simultaneously which increase the efficiency and maximize throughput.

XDL intersections can be constructed fully or partially. Full XDL intersection has the DLT (displaced left turn) movements on all four approaches. However, partial XDL intersection has the DLT movements on two opposing approaches only as shown in Figure 1. Vehicles driving on the main road can make right turns at the intersection just as in the conventional intersection. However, it may need to yield to the opposing lefts. The displaced left turn bay allows more capacity on the road; it extends between the primary and secondary intersections. Full XDL intersections can be defined as a system that has one primary and four secondary intersections. These intersections use two phase signalizations which have shorter and more efficient cycle lengths.

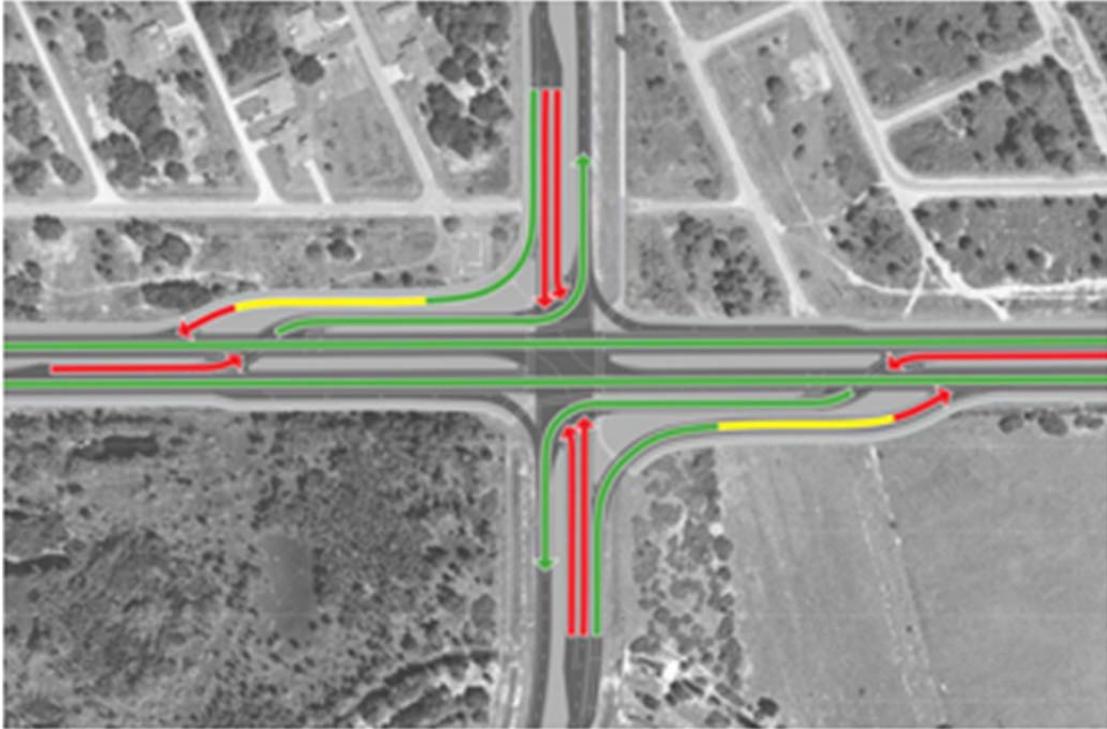

Figure 1: Partial XDL Intersection on Eastbound and Westbound Approaches

1.2.3 Analysis

VISSIM was used to compare between the XDL intersection (see Figure 2) and the conventional intersection. The conventional intersection model included the left turn movements as protected permissive. Three different spacing distances were tested for the distance used between the primary and secondary intersections. The three spacing distances utilized were 300 ft (90 m), 400 ft (120 m), and 500 ft (155 m). These distances were tested to select the most cost effective option that also provided the least amount of spillback. SYNCHRO was utilized to calculate and compare the cycle length, delays, queues, and stops for the intersections while regulating the timings on the signals. Simulation volumes were selected under three conditions; Balanced and Unbalanced, Peak and off peak, different Left turn volume conditions.

1.2.4 Performance Measures

- The XDL was tested under balanced volume scenarios:
 - The results showed that increasing the distance between the primary and secondary intersection would increase the capacity. The only downfall would be a slight increase in delays at low volumes.
 - Under all the volume levels, the XDL intersection displayed the least amount of delay when compared to the conventional intersection.
 - The XDL's capacity was about 90 percent higher than the capacity of the conventional intersection.

- The XDL intersections exhibited the lowest amount of delays for all through volumes.
- When analyzing left turn volumes of 220 vph, the conventional intersection exhibited the lowest number of left turn delays.
- When analyzing left turn volumes between 220-500 vph, the XDL intersection exhibited the lowest number of left turn delays.
- The XDL was tested under unbalanced volume scenarios through SYNCHRO:
 - The two major volumes tested were 1200 and 1500 vehicles/hour/approach.
 - Under the two volume scenarios above, the XDL outperformed the conventional intersection.
 - Left turn delays increase under the XDL intersection whenever left turn volumes are increased.
 - Although the increase in left turn volumes negatively affects the XDL method, it affects the conventional intersection method much worse.
- The XDL performed best and had higher capacities under scenarios with long distances between the primary and secondary intersections.
- The XDL is highly recommended in locations where right of way is not problematic.

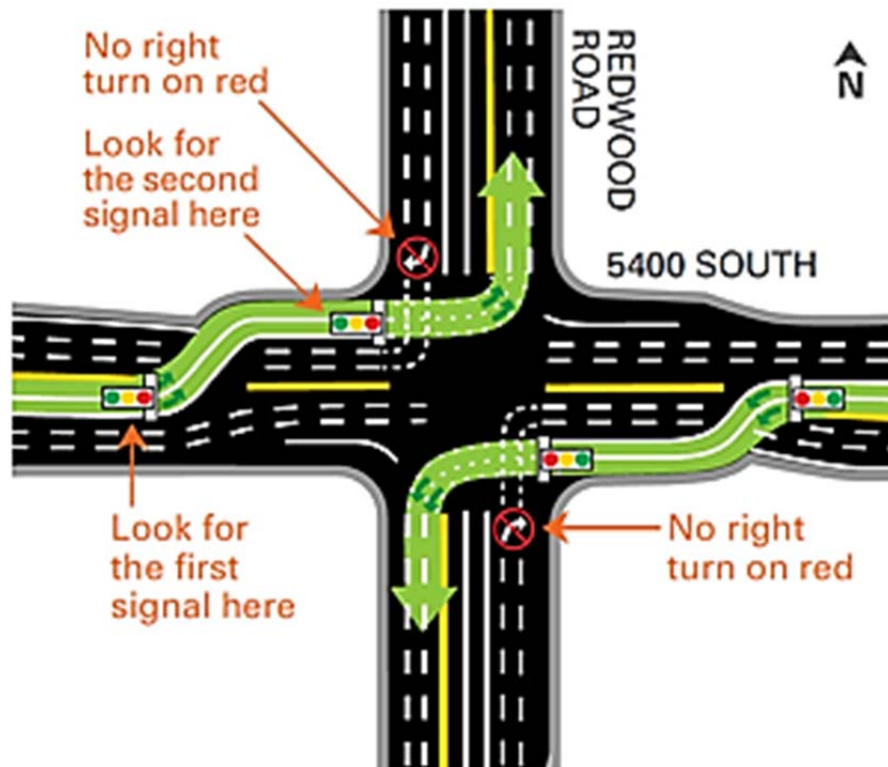

Figure 2: XDL Design and Operation



1.2.5 Further Studies and Reports

Jagannathan and Bared (2004) evaluated the performance of the XDL intersection using VISSIM simulations. The XDL intersection was compared to the conventional intersection. Three XDL designs with different geometries were tested and compared to the conventional intersection. Pedestrian crossing times had to be accounted for and had to be optimized in order to achieve the benefits of the XDL alternative. The medians analyzed were 10 ft long by 10 ft wide and were used as refuges for pedestrians.

Through simulation, three different cases were modeled and analyzed. The first case (A) was a four legged intersection with four displaced left turns. The second case (B) was also a four legged intersection but in this case only the major road had opposing displaced left turn lanes. The third case (C) utilized one displaced left turn lane on a T-intersection. The first case (A) had 743 random scenarios, the second case (B) had 714 random scenarios, and the third case (C) had 262 random scenarios. The results of the simulation testing between the three cases and the conventional intersections are listed below. The authors also developed statistical models utilizing nonlinear regressions and SAS software in order to compare delays between the cases and the conventional intersection (Jagannathan and Bared, 2004)

The results of the simulation showed that the XDL outperformed the conventional intersection in all the cases. This alternative intersection even outperformed the conventional intersection at low volumes. Reductions in delays and increases in capacity were greatly noted due to the reduction in the number of phases through the XDL intersection.

XDL average intersection delay results:

- First case (A) – 48 to 85 percent reduction
- Second case (B) – 58 to 71 percent reduction
- Third case (C) – 19 to 90 percent reduction

XDL average number of stops results:

- Unsaturated flows – 15 to 30 percent reduction
- Saturated flows – 85 to 95 percent reduction

XDL average intersection queue length results:

- First case (A) – 62 to 88 percent reduction
- Second case (B) – 66 to 88 percent reduction
- Third case (C) – 34 to 82 percent reduction

XDL intersection capacity results:

- First case (A) – 30 percent increase
- Second case (B) – 30 percent increase
- Third case (C) – 15 percent increase

It can be concluded that the XDL intersection was more effective than the conventional intersection. It is also cost efficient alternative for intersections with high volumes. Other researchers have done studies and tests comparing the XDL and conventional intersection. They all had positive responses to the alternative intersection method; from their research they all



concluded that the XDL outperformed the conventional intersection. Some of these researchers include (Reid 2000), (Hummer, 1998 and 2000), and (Chlewicki, 2003).

Park and Rakha (2010) evaluated the safety and operational performance of the XDL intersections in the United States using field and simulation tests. The XDL intersection was studied to assess how they affected drivers, safety, operations, and the overall environment. Field studies were performed through video analysis. Two existing XDL intersections were analyzed; the first one is located at the intersection of Bangerter Highway and 3500 South, West Valley City, Utah. The second intersection is located at the intersection of Airline Highway and Siegen Lane, Baton Rouge, Louisiana.

XDL (West Valley City, Utah)

- Video recordings were captured on September 2007 when the XDL intersection was opened and a year later on September 2008.
- The field data showed 279 events on 2007 and 136 events on 2008. 91 percent of these events consist of “improper lane change”, “diverge”, and “red light violations”.
- The “diverge” and “repeated lane change” events seem to have occurred due to the new and unrecognized maneuvers of the intersection.
- 36 percent out of the total events occurred from the “diverge” event. The “diverge” events all have to do with some form of premature lane diverging.
- The “diverge” events decreased from 125 to 49 between 2007 and 2008.
- Overall the events decreased by 51 percent in the span of year. This was a positive sign showing that the XDL intersection was effective and people were getting accustomed to its maneuvers.

XDL (Baton Rouge, Louisiana)

- Video recordings were captured on April 2007, a year after the XDL intersection was opened.
- 108 total events were recorded for the north and southbound.
- 44 percent out of the total events occurred from the “red light violation” event.
- 38 percent out of the total events occurred from the “diverge” event.
- 15 percent out of the total events occurred from the “improper lane change” event.
- The northbound approach showed to capture more events than the southbound approach. A major concern on the northbound approach that resulted in a high number of events were the red light violations.
- Overall there was no clear conclusion from this field test due to the lack of comparisons to previous data. It was noted that many of the events were most likely caused by XDL intersection confusions.

Simulation testing was done using VISSIM, INTEGRATION, and VT-Micro to model an XDL intersection. Field data from the Utah DOT was provided in order to create a proper model. The intersection of Bangerter Highway and 3500 south was simulated. The performance results for both the VISSIM and INTEGRATION software can be seen on Table 2. VT-Micro analyzed the



fuel and emissions on the intersection through 12 different models. Delay, fuel use, and emissions decreased on the XDL intersection when compared to the conventional intersection.

Table 2: XDL versus Conventional Intersection Network Performance

Measure of Effectiveness (MOE)	INTEGRATION				VISSIM			
	No Build	Build	Diff	Rel Diff	No Build	Build	Diff	Rel Diff
Vehicle trips	9786	9878	92	1%	9587	9942	354	4%
Avg. speed (km/h)	39.4	44.6	5	13%	34.5	41.3	7	20%
Vehicle stop	13504	12327	-1177	-9%	10366	7892	-2474	-24%
Avg. vehicle-stops	1.4	1.2	-0.2	-10%	1.1	0.8	-0.3	-27%
Total delay	801858	626492	-175366	-22%	617453	445240	-172214	-28%
Avg. total delay	81.9	63.4	-19	-23%	64.4	44.8	-20	-30%
Stopped delay	427784	304166	-123618	-29%	498040	346697	-151344	-30%
Avg. stopped delay	43.7	30.8	-13	-30%	51.9	34.9	-17	-33%
Fuel (liter)	1515	1443	-72	-5%	1547	1375	-172	-11%
HC (gram)	872	863	-8	-1%	346	327	-19	-5%
CO (gram)	317295	314877	-2419	-1%	7498	7222	-276	-4%
NO _x (gram)	1841	1812	-29	-2%	1756	1657	-99	-6%
CO ₂ (gram)	3451245	3281994	-169252	-5%	3604061	3199509	-404552	-11%

The number of trips on the intersection also increased on the XDL intersection. The XDL increases the average speed on the intersection by 13 and 20 percent. There was also an energy savings of 5 and 11 percent on the XDL intersection. HC, CO, and NO_x emissions decreased by one to six percent on the XDL intersection; CO₂ emissions were also reduced. On the XDL intersection, highest improvement was recorded on the eastbound direction. Simulations also showed that the conventional intersection was more sensitive to demand variations than the XDL intersection. Overall the XDL intersection outperformed the conventional intersection, especially in scenarios with high traffic volumes (Park and Rakha, 2010).



1.2.6 Best Practices

XDL (Missouri Route 30 and Summit Drive, Fenton, MO)

The first Displaced Left Turn Intersection in Missouri was installed in 2007 when a large commercial development called Gravois Bluffs opened across from a residential area. The existing intersection had a low level of service due to the increased traffic, which limited the area's economic growth potential and hindered continued development on the corridor. After the implementation of the XDL, the intersection is currently servicing up to 50,000 vehicles a day, this intersection design proved to have several benefits, including:

- Improved level of service.
- Accommodates economic developments.
- Increased corridor capacity for future travel volumes.
- Fewer and less severe crashes, most being property damage only.
- Decreased cost when compared to separating the two roads with an interchange.

XDL (6200 South at Redwood Road, Taylorsville, UT)

The Problem started when a nearby interchange with I-215 caused severe congestion at the intersection of 6200 South and Redwood Road during both the morning and afternoon peak traffic periods. The only solution was to convert the conventional intersection to a displaced left turn configuration as part of a systematic application on the corridor. Results showed:

- The new intersection moves traffic so efficiently, the city of Taylorsville decided to widen 6200 South Street, further increasing throughput.
- The nearby interchange experience reduced congestion due to the improved flow.

XDL (Bangerter Corridor, Salt Lake County, UT)

The Bangerter Highway corridor had a high crash rate and heavy delays. At some intersections, 25 percent of the signal time was devoted to left turns onto the minor roads, impeding both through traffic on the minor roads. The proposed solution was the installation of two-legged and four-legged DLT intersections at seven locations on the corridor to help alleviate congestion and improve flow. The outcome:

- Commute time along the corridor has been reduced by 3 ½ minutes.
- More than 800,000 gallons of fuel have been saved.
- Construction costs have been reduced by \$20-40 million.
- Crashes within ¾ of a mile of the initially treated intersection have been reduced by as much as 60 percent.
- Capacity along the corridor has increased by as much 20-50 percent, depending on the intersection.

1.3 Diverging Diamond Interchange (DDI)

1.3.1 Introduction

Diverging Diamond Interchange (DDI) is another alternative treatment that alleviates traffic congestion through the elimination of the conventional left turns. In some regions, it may also be known as the Double Crossover Diamond (DCD) Interchange. To avoid confusion, we refer to this unconventional alternative as the Diverging Diamond Interchange (DDI) throughout the rest of this literature review. This alternative provides various benefits to drivers as well as engineers. It is cost effective and provides a safer alternative to the drivers, pedestrians, and bicyclists.

1.3.2 Operation

The DDI's main purpose is to relocate the traffic in an efficient and safe way. As shown in Figure 3, the eastbound and westbound lanes will cross over each other and will allow the drivers to drive on the opposite side of the road. This will allow the drivers to make left turns on to the access ramps without having any contact with the opposing through traffic. The left turns are not signalized and the drivers are allowed to make left turns without any major precautions. The new configuration acts as a one-way road with left turns operating freely as the conventional right turns. As the drivers proceed through the DDI, they will eventually be rerouted back to their original side of the road. Vehicles turning right at the interchange will have the ability to enter a right turning lane before reaching the first signalization. Vehicles approaching the interchange from the north/southbound will be able to turn left, right, or pass through the interchange. The left turns are conflict free from opposing traffic.



Figure 3: DDI Design

1.3.3 Analysis

Rotoli (2009) analyzed the utilization of the DDI on the interchange of I-590/Winton Road in the Town of Brighton, New York. Traffic operations at the I-590/Winton Road interchange, which was converted to a DDI were analyzed through the use of simulation. The length analyzed on the I-590 is about 1.24 miles (2.0 km) and the length analyzed on Winston Road is about 0.93 miles (1.5 km). The peak periods for the AM and PM hours were thoroughly analyzed. The 3D model allowed the public to visualize and understand the DDI properly as shown in Figure 4. The variables analyzed were safety, congestion, and cost.



Figure 4: 3D Model in VISSIM for DDI



1.3.4 Performance Measures

- The DDI increases safety and capacity while reducing construction cost and congestion.
- The use of DDI will essentially replace cloverleaf ramps and their high costs.
- The DDI overall improves the performance and efficiency of an interchange through a sequence of coordinated phases.
- Time lost due to numerous phases can be recovered through longer green time allocation to critical phases
- DDI is an economical method to resolve problems for tight design areas.
- The reduction of conflict points through DDI improves the safety on the interchange.
- The DDI resulted in a smaller footprint which also led to a reduction in carbon footprint.
- DDI also greatly improved safety for pedestrians and bicyclists by completely removing direct left turns.
- Due to reduced footprint, DDI saved seven million dollars when compared to the cloverleaf design.
- The reduced footprint consists of the removal of cloverleaf ramps, widening of deceleration lanes on interstate bridges, and the reduction of arterial widening.
- Capacity improvements:
 - Intersections – 15 percent increase
 - Corridor with the least phases and movements- 60 percent increase
- Safety improvements:
 - DDI has 24 less conflict points when compared to the diamond interchange
 - Diamond interchange – 45 conflicts
 - DDI – 21 conflicts
 - DDI reduces crash severity
- Cost savings:
 - Cloverleaf estimated cost – \$10,500,000
 - DDI estimated cost – \$3,500,000
- The simulation model educated the public and stakeholders through visualizations.
- The visualizations also met the Safe, Accountable, Flexible, Efficient Transportation Equity Act: A Legacy for Users (SAFETEA-LU) requirements of the Federal Highway Administration.

Hughes et al. (2009) discussed the design, controls, and performances of the Double Crossover Diamond Interchange / Diverging Diamond Interchange.

- Delays- reduced by 15-60%
- Throughput- increased by 10-30%
- Conflict points- 21 less than the conventional interchange
- Reduced speeds while still maintaining a high capacity
- Fewer crashes; Less severe crashes
- Improved safety due to less vehicle exposure time
- Elimination of wrong way movements



1.3.5 Further Studies and Reports

Chlewicki (2003) analyzed the performance of the Diverging Diamond Interchange which was implemented to ease heavy turning movements on the interchange. The interchange included two signals on each crossover; these signals are two-phased. The DDI was compared to the standard diamond interchange through Synchro simulation. The designs used identical lane configurations and fixed time signals were utilized to reach an effective comparison between the designs. Travel speeds, turning speeds, and truck percentages were also kept constant. Total delays, stop delay, and total stops were evaluated. I-695 (Baltimore Beltway) and MD 140 (Reisterstown Road) in Baltimore County, Maryland was the interchange to analyze. This heavy turning interchange was very busy and the movements can be seen in Table 3.

Table 3: Turning Movement Volumes for Interchange

EB MD 140		WB MD 140		SB Ramp I-695	
Thru	Right	Left	Thru	Left	Right
1212	472	389	1119	328	665
EB MD 140		WB MD 140		NB Ramp I-695	
Left	Thru	Thru	Right	Left	Right
446	1094	1033	367	475	408

The DDI had fewer total delays when compared to the conventional diamond interchange. In Table 4, it can be seen that the conventional interchange had about three times more total delays. In this table it can also be seen that the conventional interchange has over four times more stop delays than the DDI. The DDI also outperformed the conventional interchange in the number of total stops. The conventional diamond interchange had about twice as many stops (Chlewicki, 2003).



Table 4: DDI versus Conventional Interchange Comparisons

	Conventional	DDI*	Signalized DDI*
Total Delay (hr)	107.1	37.1	35.9
Delay / Vehicle (sec)	80.2	26.7	26.1
Stop Delay (sec)	83.4	19.7	19.4
Stop Delay / Vehicle (sec)	62.5	14.2	14.1
Total Stops	8336	4205	3960
Stop / Vehicle	1.73	0.84	0.80

Advantages of DDI

- Reduction of phases
- Lower number of conflict points
- Left turns without crossing over roads
- The capability of combining lane assignments without changing the signal’s phase
- Efficient when there are heavy left/right turns

Disadvantages of DDI

- Driver confusion with improper signage
- Poor performance when the amount of vehicles using the ramp movements are almost equal to the amount of vehicles using the mainline through movement
- Extra cost for right of ways:
 - Widened median to avoid confusion
 - Wider bridges
 - Ramp bends
- Concerns with driveway access for residents and businesses near the interchange

Figure 5 shows the crossover movement in a DDI. The turning radii utilized at the crossovers of the DDI are usually 150-300 ft. The pedestrians have crosswalks and central islands to walk through the interchange in a safe and efficient way. The central islands serve as refugees between the signalizations. The median between the roads can also serve as a crosswalk for pedestrians. The DDI outperforms the conventional interchange under high traffic volumes with fewer stops, shorter queue lengths, and less stop times and delays. During low volumes the conventional and diverging diamond interchange performed in a similar fashion. Results also showed that service

volumes of left turns can be increased by twice the capacity using the DDI alternative (Rotoli, 2009).

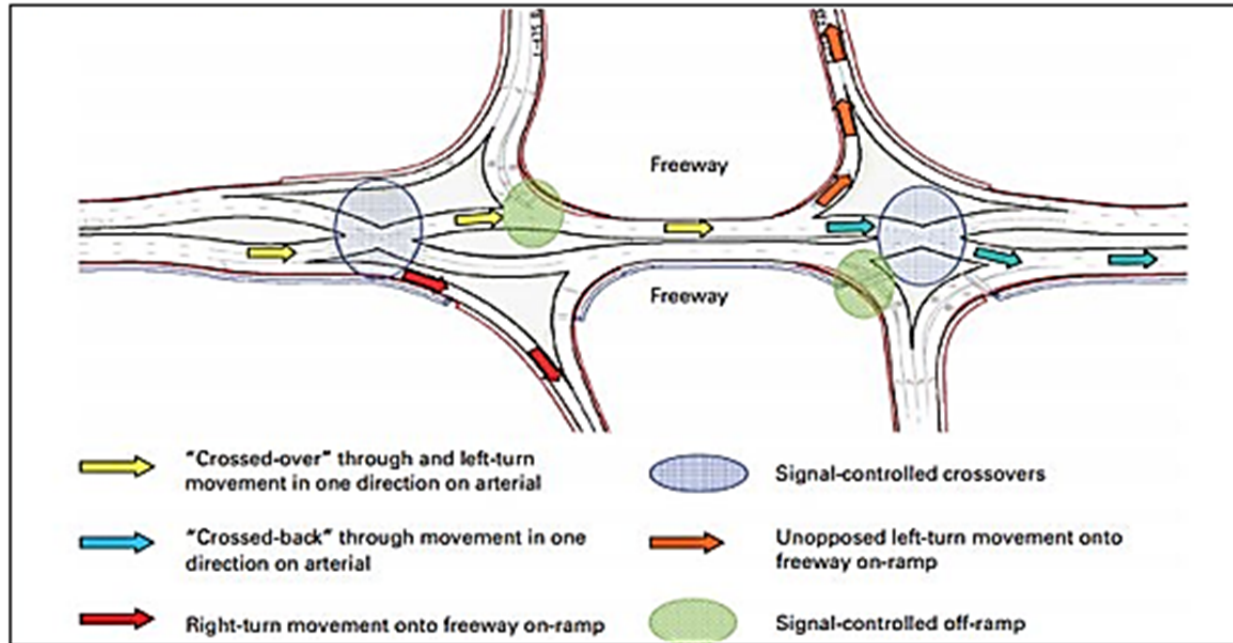

Figure 5: Crossover Movement in a DDI

1.3.6 Best Practices

DDI (Interstate 15 and Main Street, American Fork, UT)

The interchange at I-15 and Main Street experienced significant demand increases due to rapid population and commercial growth in the area. In addition, the conventional diamond interchange design had only a single lane and no left turn lane. It could take drivers 20-30 minutes to get through the interchange. The solution was the installation of the nation's second diverging diamond interchange. Results showed:

- The new DDI can comfortably accommodate 40,000 vehicles per day 10,000 more than the conventional diamond interchange alternative.
- Illuminated pedestrian walkways are provided along both sides of Main Street though the interchange, and bicyclists can choose to ride in-lane or along the shoulders adjacent to the right lanes in both directions.
- Overwhelmingly positive reaction from business and surrounding communities due to reductions in congestion and delay.

DDI (Interstate 15 and Timpanogos Highway, Lehi, UT)

The area experienced increasing population growth and traffic demand, leading to backups and delays at the interchange. Alternatives to reduce congestion had to minimize the footprint of the I-15 Bridge over the crossroad and keep the interchange within the existing right-of-way. The



proposed solution was the instillation of a DDI constructed under the highway overpass. Studies showed that:

- The renovated infrastructure has resulted in an influx of over 100 new business and 4,000 new jobs.
- The DDI design allowed UDOT to easily add two signalized crosswalks, providing safer and more convenient pedestrian facilities.
- The DDI design also integrated provisions for bicycles, including a shared use path and wide shoulders.

DDI (Interstate 44 and Missouri Route 13, Springfield , MO)

The original, conventional diamond interchange averaged more than 100 crashes a year from 2004 to 2008. In addition, traffic in the left turn lanes often caused 1 to 3 mile backups in the through lanes. After the installation of the nation's first Diverging Diamond Interchange with widespread outreach to gain public acceptance and by highlighting the mobility and safety enhancements inherent in the design, results showed that:

- Total crashes declined by 24 percent, from 91 in 2008 to 56 in 2010
- Minor injury crashes decreased by 72 percent from 2008-2010.
- Significantly reduced interchange-related congestion along the crossroad.
- Nearly 95 percent of Springfield residents agreed the DDI resulted in less congested roadway.

1.4 Double Crossover Intersection (DXI)

1.4.1 Introduction

In order to improve safety for passengers and pedestrians, engineers are implementing the Diverging Crossover Intersection alternative. Edara (2005) analyzed the performance measures of the Diverging Crossover Intersection (DXI) for vehicle and pedestrians. This alternative not only provides safety but it helps reduce congestions during peak hours. The alternative's design and benefits on heavy congested intersections is further discussed. The DXI may also be known as the Synchronized Split Phase intersection. (Edara et al., 2005)

1.4.2 Operation

The DXI, in a similar way to DDI reroutes the flow of traffic before it reaches the intersection. This alternative allows the left turns to be utilized in a safer approach. The traffic flowing on the right side going Eastbound will cross on to the left side, while the opposing traffic crosses onto their left side as shown in Figure 6. By the end of the intersection the lanes will cross back to their original side. The right-turners will use the designated lane to turn right before reaching the intersection and diverging sides. The North and Southbound traffic will be able to utilize the lanes just as a conventional intersection; it will have corresponding signalization to avoid any collisions or confusions. The radii of the crossover movements from the East and Westbound ranged from 150 ft to 200 ft. The actual left turns will have a radius of 100 ft.

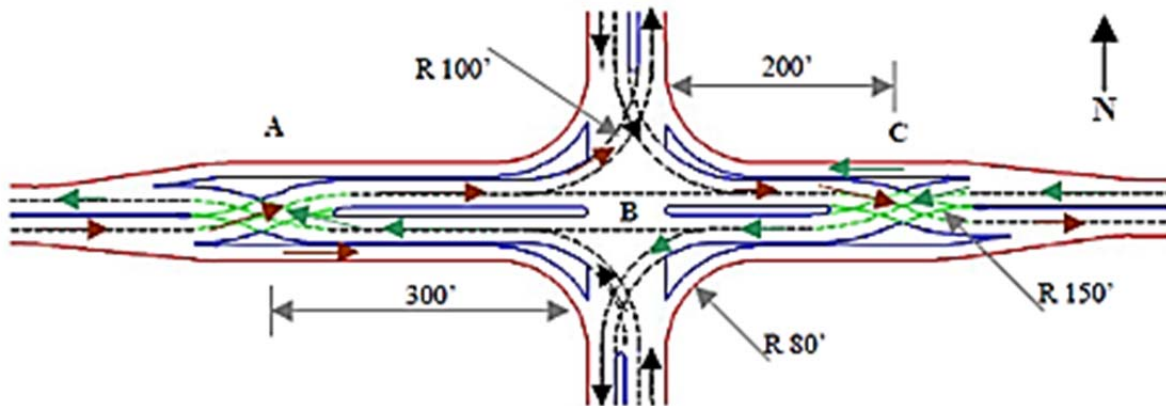

Figure 6: Design of Double Crossover Intersection (DXI)



1.4.3 Analysis

Edara et al. (2005) analyzed the DXI and conventional intersections in terms of Traffic volumes (Peak Volumes are obtained from an existing conventional intersection in Virginia), Capacity and Pedestrian analysis as shown in Tables 5, 6 and 7.

Table 5: DXI versus Conventional Intersection – Performance Results (without Peds)

Traffic Scenario	Northbound (veh/hr)			Southbound (veh/hr)			Eastbound (veh/hr)			Westbound (veh/hr)			Total Flow (veh/hr)
	L	T	R	L	T	R	L	T	R	L	T	R	
Peak	348	792	96	400	1150	144	180	842	552	100	1024	124	5752
High	348	792	96	350	1100	100	150	800	500	100	950	124	5410
Medium	175	400	50	200	600	70	90	420	275	50	500	60	2890
Low	90	200	25	100	300	35	45	210	140	25	250	30	1450

Traffic Scenario	Input Flow (veh/hr)	Model Throughput (veh/hr)		Delay Time (sec/veh)		Stop Time (sec/veh)		Number of Stops		Average Queue (ft)		Maximum Queue (ft)	
		DXI	Conv	DXI	Conv	DXI	Conv	DXI	Conv	DXI	Conv	DXI	Conv
Peak	5752	5630	4538	86	220	51	143	2.4	4.2	242	647.5	1057.1	1386.4
High	5410	5365	4540	45	174	29	105	1.2	3.4	63	490.0	392.2	1371.0
Medium	2890	2854	2856	26	36	19	29	0.8	0.7	17	46.4	166.6	238.2
Low	1450	1430	1434	25	23	19	18	0.8	0.6	8	14.0	81.1	100.7

Conv = Conventional L = Left, T = Through, R = Right

Capacity Analysis:

Table 6: Capacity of Conventional and DXI Designs

	E-W	W-E	E-S	W-N	S-W	S-N	N-E	N-S
Conventional (veh/hr)	600	450	100	100	170	575	175	575
DXI (veh/hr)	550	450	100	150	350	550	375	575

Pedestrian Analysis:

- Through simulation in VISSIM pedestrian volumes were equal to 75 peds/hr on each approach.
- The volume was split equally amongst the other directions; 25 peds/hr towards the North, East, and West directions.
- Two different type of crossings:
 1. Adjacent crossing
 2. Diagonal crossing
- Pedestrian performance was analyzed through the average delay per person per stop.



Table 7: DXI versus Conventional Intersection – Performance Results (with Peds)

Traffic Scenario	Flows (veh/hr)		Delay Time (sec/veh)	Stop Time (sec/veh)	Number of Stops	Maximum Queue (ft)
	Input	Actual				
Peak	5752	5630	149	65	3.6	1673.7
High	5410	5365	86	43	2.3	1000
Medium	2890	2854	30	21	0.9	217.3
Low	1450	1430	27	19	0.8	100.2
Pedestrians						
			Delay Time (sec/person)	Stop Time (sec/person)	Number of Stops	Average Delay per stop (sec/person)
Diagonal Crossing (e.g. S-W)			98	93	4	24
Adjacent Crossing (e.g. S-N)			63	59	2	31

1.4.4 Performance Measures

- At low/medium volumes, the DXI’s performance is nearly identical to the conventional intersection designs.
- At high volumes the DXI design performs better than the conventional intersection design.
- The model throughput for the DXI design resulted in a value similar to its input. On the other hand the conventional design had a deficit of about 1000 veh/hr on its model throughput.
- The average delay was improved through the DXI design:
 1. The conventional design average delay per vehicle was 220 sec/veh
 2. The DXI design average delay per vehicle was 86 sec/veh
- The DXI design outperformed the conventional design when comparing these measures:
 1. The number of stops
 2. Average stop time per vehicle
 3. Average queue
 4. Maximum queue length
- When analyzing the simulation with pedestrians, DXI outperformed the conventional design for high volumes.
- The capacity for left-turns on the North/Southbound is twice as large when utilizing DXI design over the conventional design.
- DXI works efficiently at intersections with substantial left-turn movements.
- When accounting for pedestrian performance, DXI had a higher number of stops for crossing when compared to the conventional intersection design.
- DXI results in the addition of two signals which lead to:
 1. Intersection complexity
 2. Safety issues



1.4.5 Further Studies and Reports

Chlewicki (2003) compared the new interchange and intersection Designs known as the synchronized split-phasing Intersection and the Diverging Diamond Interchange and concluded similar results as shown earlier. He took upon simulation testing to compare the DXI to conventional intersection. Chlewicki used SimTraffic and Synchro software to perform the simulations. The DXI outperformed the conventional and the split-phase design when comparing total delay, stop delay, and total stops at the intersection of US 29 at East Randolph Road/Cherry Hill Road in Montgomery County, Maryland. (Chlewicki, 2003)

Benefits:

- Green time extension
- Construction and right of way cost reduction
- Medians assist pedestrians when using the crossings
- Longer pedestrian signalizations

Disadvantages:

- Driver confusion
- DXI requires more geometric requirements and additional signals
- Business and residential entry conflicts
- Pedestrian/Cyclists safety issues

Autey et al (2012) compared the operational performance of four unconventional intersection designs using micro-simulation. They compared the utilization of the DXI in either the major or minor streets. The DXI with the crossovers on the major street proved to be the better performing alternative. The DXI works more efficiently when there is heavier traffic on the street. They also compared DXI to other forms of alternatives and the DXI was tested using different intersection spacing distances, volumes, and left turn traffics. The alternative intersection analysis concluded that no single design truly outperforms the other; it all depends on the circumstance. Overall the average vehicle delay and capacity of the unconventional intersections outperformed the conventional intersection. (Autey et al., 2012)

1.4.6 Best Practices

The Diverging Crossover Intersection (DXI) is also similar to CFI, which is mainly to treat the heavy left-turns at the intersection in a safer way. However, from the literature, it was found that CFI always provided better performance over DXI. Therefore, there is no best practice on DXI.



1.5 Median U-Turn (MUT)

1.5.1 Introduction

An alternative treatment that completely removes left turns at the intersection is the Median U-Turn (MUT). MUT is a unconventional intersection alternative that helps reduce the number of delays and signal phases while at the same time allowing the intersections to increase in capacity. This alternative also enhances safety at the intersections since it avoids any conflicts through left turns. This technique has been utilized frequently in Michigan and, in some reports, is known as the Michigan U-turn or Michigan Left. Bared and Kaisar (2002) studied Median U-turn designs as an alternative treatment for left turns at signalized intersections including the performance of the Median U-turn as well as safety enhancements (Bared and Kaisar, 2002).

1.5.2 Operation

The Median U-Turn omits the conventional left turn lanes at the intersection (usually both major and minor roads) as shown on Figure 7. The through movements are kept unchanged at the intersection, which reduces the number of phases to two phases to improve the throughput capacity. Left turning drivers on the minor road need to make a right at the intersection and then a U-turn at a median crossover. After completing the U-turn at the crossover, the drivers then proceed on the major road. The drivers heading east- or west-bound on the major streets are also not permitted to make left turns; instead, they will pass the intersection and utilize the U-turn crossover. A lane is added to the right side of the opposing lanes to facilitate the U-turns being made. The incoming traffic from the U-turns will be able to utilize an acceleration lane on the right side of the road to assist in the transition. In most cases, jug handles, bulb-outs, or wide medians are constructed in order to allow large vehicles to utilize the U-turns. A bulb-out can be seen in Figure 8 displayed inside the red circle; the acceleration lane can be seen following the bulb-out. Converting a conventional intersection into a MUT alternative will only require additional land for jug handles or bulb-outs. Eliminating left turns at the main intersection accounts for the most benefit through the 2-phase signal operation (Bared and Kaisar, 2002).

Median U-Turn Characteristics:

- U-turn crossovers are 450 ft (137 m) from the intersection
- Left-turn pockets are 400 ft (122 m) long

AASHTO Requirements for WB-15 vehicles making 180° turns:

- Minimum inside turning radius of 19 ft (5.9 m)
- Maximum outside turning radius of 46 ft (14.1 m)

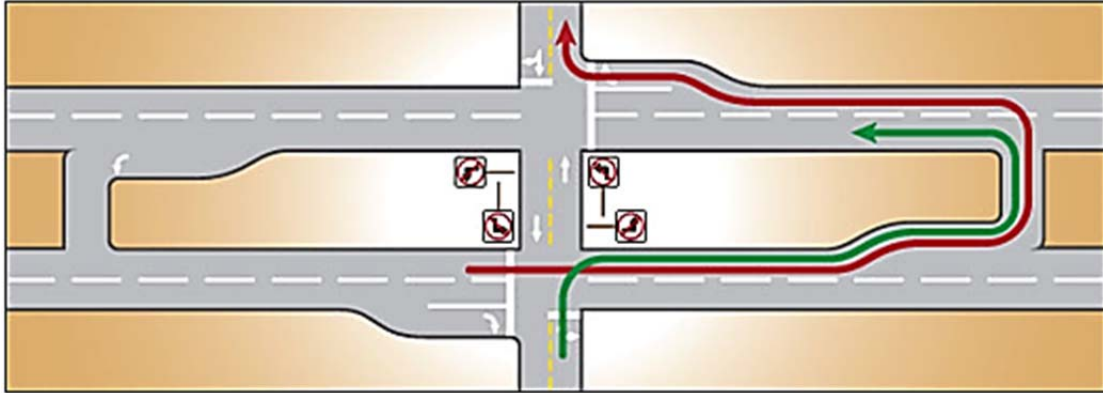

Figure 7: U-Turn Movements at MUT

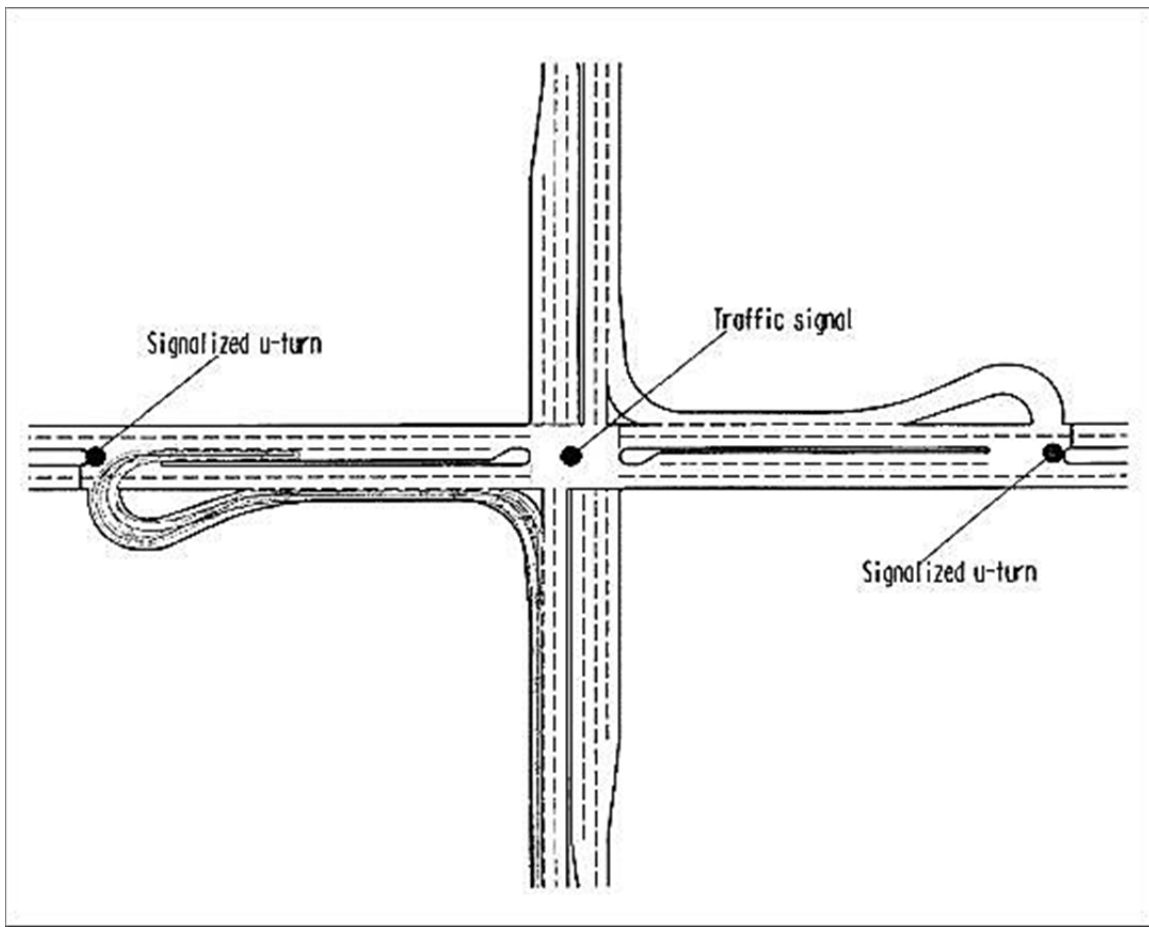

Figure 8: Design of a Median U-Turn (MUT)



1.5.3 Analysis

Bared and Kaisar (2002) compared a MUT treatment to a conventional intersection using CORSIM simulation model. The design being compared contained two lanes in each direction. The median U-turn diagram will be identical in length to the conventional diagram. Two traffic flow cases were considered. The first case utilized 10% left turning flows, while the second case used 20% left turning flows. The right-turning flows remained constant at 10% for all cases. The truck flows also remained constant at 5%.

1.5.4 Performance Measures

- On left turns, travel time was longer in MUT intersections than Conventional designs.
- When comparing the average network travel time, MUT performs better in high volumes.
- Time travel savings increased from 10 to 40 s/veh
- Larger savings started after volumes reached 6600 vph
- Average vehicle stops were about 20 to 40 percent lower for the MUT.
- Overall the MUT showed a significant reduction in the network travel time
- There is no true or discovered advantage of utilizing longer left turning lanes.
 - Could increase travel time if offsets are longer
 - Could also be very beneficial in high traffic situations
- MUT design is less expensive than dual left-turn lanes.
- MUT design is safer than dual left-turn lanes.
- MUT design is more efficient at high volumes than dual left-turn lanes.

1.5.5 Further Studies and Reports

Hummer (1998) analyzed the Median U-Turn intersection and concluded that the MUT alternative should be utilized when there are high through arterial volumes, median, high left turn volumes, and where the cross-street through volumes are insignificant. Heavy left turn volumes cause extra delay outweighing the benefits of the MUT alternative. In this alternative, narrow medians without the ability of widening are not very beneficial on arterials unless the wide medians could be built on the minor street. AASHTO recommends a median width of 60 ft when a large semi-trailer is used as the design vehicle on a four lane major road. Hummer stated that agencies have found 600 ft to be a favorable distance between the intersection and the crossover. The Median U-turn alternative is utilized most by the Michigan Department of Transportation in the U.S. Michigan has used the MUT method for over 30 years and has over 1000 miles in service.



The advantages and disadvantages when comparing the MUT intersection and the conventional intersection are described below (Hummer, 1998):

Advantages

- Through arterial traffic delay is reduced
- Through arterial traffic progression is easier
- Through traffic has fewer stops
- Crossing pedestrians have fewer threats
- Conflict points are reduced and separated

Disadvantages

- Left turning traffic delay is increased
- Left turning traffic travel distance is increased
- Left turning traffic stops are increased
- Driver confusion
- Drivers may neglect the prohibition of left turns on the main intersection
- Right of way must be larger along the arterial
- Increase in operational cost due to extra signalization needed
- Cross-street minimum green times may need to be longer

Hummer and Reid (2000) provided an update to evaluate the capacity and efficiency of the MUT alternative. They concluded that median U-turns increase capacity due to the reduction of signal phasing, but at the same time they decrease the capacity because the vehicles using the crossover pass through the intersection more than once. The capacity also may decrease due to lack of approach lanes available. Table 8 shows a comparison on the capacity of the intersection between the conventional and median U-turn. This table shows the ratio between the critical volume and the capacity of the MUT when utilizing the maximum cycle length. This ratio is a measure of the intersections throughput without the effect of the signal timing. It was concluded that MUTs have a higher volume to capacity ratio by 0.1 (Hummer and Reid, 2000).



Table 8: MUT and Conventional Intersection Capacities

Arterial		Cross street ADT	Critical v/c with 180-second cycle			
ADT	Dir. Split		20% turns		40% turns	
			Med. U-turn	Conv.	Med. U-turn	Conv.
15,000	60	15,000	0.49	0.56	0.61	0.69
		25,000	0.65	0.74	0.83	0.93
	70	15,000	0.58	0.69		
		25,000	0.77	0.91		
20,000	60	15,000	0.57	0.66	0.7	0.81
		25,000	0.73	0.84	0.93	1.05
	70	15,000	0.68	0.81		
		25,000	0.86	1.03		
25,000	60	15,000	0.66	0.76	0.79	0.81
		25,000	0.82	0.94	1.02	1.05
	70	15,000	0.77	0.93		
		25,000	0.96	1.15		
30,000	60	15,000	0.74	0.86	0.88	0.9
		25,000	0.9	1.04	1.11	1.14
	70	15,000	0.87	1.05		
		25,000	1.06	1.27		
35,000	60	15,000	0.63	0.78	0.98	0.99
		25,000	0.79	0.96	1.2	1.23
	70	15,000	0.74	0.95		
		25,000	0.93	1.17		
40,000	60	15,000	0.69	0.85	1.07	1.08
		25,000	0.84	1.03	1.29	1.32
	70	15,000	0.81	0.93		
		25,000	1	1.15		

Hummer and Reid used CORSIM software and data from an existing MUT arterial in suburban Detroit, Michigan to compare it to a superstreet and two-way left turn lanes (TWLTLs). They utilized SYNCHRO simulation to adjust the signal timing. The TWLTLs were utilized with protected left turn phases. The through traffic was varied between 10 to 25 percent. Table 9 shows the results from the simulation experiment; each row represents the mean from 12 half-hour runs. (Hummer and Reid, 2000)

MUT Arterial Characteristics:

- 2.5 miles long
- 5 unevenly spaced signals
- 4-6 through lanes
- 52000-60000 ADT
- 50 mph speed limit



MUT compared to TWLTL:

- In the four time periods, MUT had a higher vehicle speed (**GREEN**)
- MUT had a superior total system time at the peak times (**RED**)
- The MUT and TWLTL were nearly identical in total system time (**BLUE**)
- MUT had more stops per vehicle in the Noon and Midday periods (**LIGHT BLUE**)
- The MUT and TWLTL were nearly equal in the number of stops during the two peak periods (**YELLOW**)

Table 9: Simulation Results (Hummer and Reid, 2000)

Time of day	Major street geometry	Total system time, veh.-hrs.	Mean stops per veh.	Mean speed, mph
A.M. peak	TWLTL	302	1.95	14.5
	Median u-turn	254	1.98	22.4
	Superstreet	283	2.36	18.2
Noon	TWLTL	136	1.45	25.9
	Median u-turn	137	1.75	28.5
	Superstreet	142	1.84	27.4
Midday	TWLTL	162	1.53	24.6
	Median u-turn	159	1.82	27.3
	Superstreet	164	1.86	27
P.M. peak	TWLTL	403	2.08	13.3
	Median u-turn	280	2.19	19.2
	Superstreet	314	2.59	17.3
Mean, all times	TWLTL	251	1.75	19.6
	Median u-turn	208	1.94	24.4
	Superstreet	226	2.16	22.5

A research group at Michigan State University performed a similar study. They also utilized CORSIM and compared Median U-turns to two-way left turn lanes. They concluded similar results to those presented in Table 9. According to their results, saturation levels above 50 percent showed that MUT saved approximately a minute per vehicle when compared to TWLTL during volumes of ten percent left/right turns. They also studied collision rates on MUTs, TWLTLs, and roads with medians and conventional left turns. The collision data collected over five years in Michigan is displayed in Table 10. The sample size utilized in this data ranged from 36 to over 300 sections per arterial category. Approximately 1000 miles of roadway were being represented. Table 10, concludes that arterials with medians had less collisions than TWLTL in nearly all collision types. MUT had fewer collisions than conventional left turns when signalizations were utilized.



Table 10: MUT Collision Rates from Michigan

Collision type	Reported collisions per 100 million vehicle miles					
	Unsignalized			Signalized		
	TWLTL	Conv. median	Median U-turn	TWLTL	Conv. median	Median U-turn
Rear end	150	40	100	490	360	340
Angle-Straight	30	10	0	120	20	20
Angle-turn	40	10	20	80	50	40
Head-on Left turn	20	10	10	130	70	20
Driveway Related	110	10	20	200	40	40
Other types	120	100	70	210	210	140
Total of above	460	180	220	1220	750	600

1.5.6 Best Practices

MUT (Woodward Avenue and East Maple Road, Birmingham, MI)

A heavily traveled intersection servicing approximately 55,000 vehicles per day experienced queued traffic and high rates of crashes among left turning vehicles. This was complicated by an adjacent intersection approximately 150 feet away. The solution included a Median U-Turn design that allows for efficient movement, while reducing conflict zones and improving safety for pedestrians. The result:

- More vehicles flowing freely along both streets and increased access to adjacent businesses.
- Brick truck aprons at the U-turns ensure easy movement of truck traffic.
- Signals changed to a two-phase operation, giving more time for pedestrians to cross intersection safely.

MUT (Corridor Applications, Detroit, MI)

A series of wide medians on several corridors in the Detroit metro area caused congestion and conflicts among vehicles attempting to make opposing left turns. Application of the Median U-Turn intersection design on corridor-wide bases throughout the Detroit area provided:

- Near elimination of congestion on main arterial roads.



- Fewer accidents occur because there are no direct left turns or areas where opposing traffic can meet in a head-on collision.
- Pedestrians only have to cross one direction at a time and only have to look one way at a time making their crossing safer.

MUT (Michigan Avenue and South Harrison Road, East Lansing, MI)

This busy intersection experienced lengthy queues of left turning vehicles. The result was congestion that restricted through movements and threatened the safety of a significant number of pedestrians and bicyclists. The conversion of the intersection to a Median U-Turn to improve access to non-motorized users and increase throughput showed:

- Improved pedestrian and bicycle facilities at both signalized and mid-block crossings to increase safety and mobility for these users.
- Increased throughput due to the elimination of queuing at the signal.

1.6 Restricted Crossing U-Turn (RCUT)

1.6.1 Introduction

The Restricted Crossing U-turn (RCUT) alternative is an innovative design that improves safety and operations by changing how minor road traffic crosses or make left turns at the major road intersection. The RCUT does not change any of the movements on the major road. At an RCUT, drivers on the minor road must make a right turn on the major road to navigate to a U-turn located 400 to 1000 feet from the intersection, either signalized or unsignalized to continue to the desired direction as shown below. The RCUT is also known as the J-turn or superstreet intersection. Inman and Haas (2012) studied the operations, safety, and performance of RCUT intersections. Although this method may add a little bit of travel time to the left turn users, it eliminates accidents and is consequently increasing the overall safety of the intersection. Nine RCUT intersections were analyzed in Maryland and compared to the conventional intersections. Crash analysis was one of the variables analyzed; comparing the crash rate before and after the RCUT intersection was implemented (Inman and Haas, 2012)

1.6.2 Operation

The RCUT is an alternative utilized to completely remove the left turn for traffic going from minor roads to highways. It allows turning right at the intersections. From there on they can utilize a median to make a U-turn and either proceed through the intersection or turn right. The drivers on the major highway are permitted to cautiously make left turns at the intersection. This alternative mitigates the minor road left turns and facilitates the left turns for the highway users.



Figure 9: Channelization for Left Turns at RCUT



1.6.3 Analysis

The highway analyzed was located in Frederick County on U.S. 15. The results of the analysis are shown on Table 11. Before and after comparisons of crashes were also taken into account during this study (Inman and Haas, 2012).

- DDUT (Dedicated Directional U-Turns): were permitted U-turns starting from the main intersection
- Inter: U-turns made at conventional intersection
- RCUT: U-turn made at another RCUT intersection after through or left turn movement

Table 11: Comparisons between RCUT and Conventional Intersections

Intersection	Log Mile*	Deployment Date	Approaches	Southern U-Turn Location	Northern U-Turn Location
U.S. 15 at Hayward Road	16.180	9/1988	4**	DDUT at 15.829	Inter at 16.530
U.S. 15 at Willow Road	17.070	11/1992	4	Inter at 16.530	Inter at 18.020
U.S. 15 at Biggs Road	18.020	11/1992	4	RCUT at 17.070	RCUT at 18.330
U.S. 15 at Sundays Lane	18.330	11/1992	4	RCUT at 18.020	RCUT at 18.870
U.S. 15 at College Avenue	34.210	8/1994	4	DDUT at 33.823	DDUT at 34.619
U.S. 15 at U.S. 15 Business	35.020	9/1988	4	DDUT at 34.619	DDUT at 35.477
U.S. 301 at Main Street	12.380	1/2003	4	U-turn	Inter at 12.880
U.S. 301 at Del Rhodes Avenue	12.880	1/2003	4	Inter at 12.380	DDUT at 13.146
U.S. 301 at Galena Road	43.670	1/2002	4	DDUT at 43.360	DDUT at 43.905

1.6.4 Performance Measures

- RCUT are safer form of stop or yield control on the minor roads along rural, high speed and four lane divided highways.
- Total number of conflicts is reduced from 32 to 18 (nearly 50% reduction).
- Overall the RCUT and conventional intersections have similar weaving results.
- When comparing travel time in regards to through and left turn movements, the RCUT takes about a minute longer than the conventional intersection.
- In high traffic scenarios, lag and travel time would most likely be longer in conventional intersections.
- Acceleration lanes were mostly utilized for right and U-turns when there was traffic in the through lanes.
- Although acceleration lanes aren't always utilized they are vital for the RCUT design to run smoothly in all cases.
- The crash analysis utilized showed a decrease between 28 and 44 percent.

- The crash severity was lower for the RCUT design. In regards to crashes with major injuries or fatalities, the RCUT showed nine percent reduction.

1.6.5 Further Studies and Reports

Bared (2009b) studied the design, performance, and pedestrian movements for an RCUT intersection. The RCUT alternative has been implemented in several states such as Maryland, Michigan, and North Carolina. In order to accommodate large trucks, medians widths of 40-60 feet are utilized. Bulb-outs are used at intersections with narrower medians. These bulb-outs facilitate large trucks making U-turns.

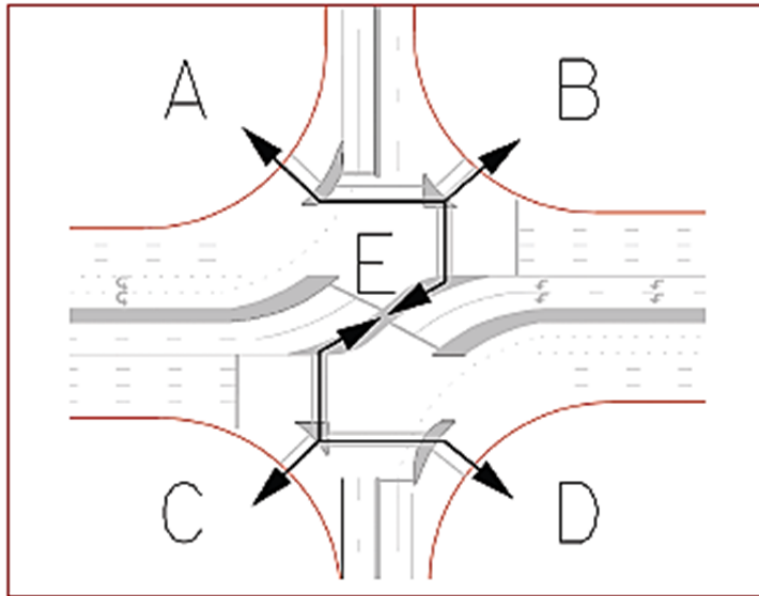

Figure 10: Pedestrian Movements at an RCUT Intersection

AASHTO recommends spacing between 400 to 600 feet for the distance between the U-turn crossover and the main intersection. However, each Department of Transportation has its own standards and recommendations for the proper spacing between the intersection and crossover. On the major road the pedestrian crossings are set up as a diagonal path that goes from one corner to the opposite corner. The pedestrian crossings can be seen in Figure 10.

VISSIM software was utilized to compare the RCUT and conventional approach. Three traffic scenarios and five different RCUT designs were analyzed. A 30 percent increase in throughput was reported in the case of the RCUT. There was also a 40 percent reduction in travel time. Regarding safety, it was concluded that the RCUT was the safer approach. There were 18 conflicts reported in the RCUT testing, while the conventional intersection testing reported 32 conflicts. Field studies proved the RCUT to be safer than the conventional intersection. There was an overall decrease in crashes, crash rates and injury/fatalities on the U.S. Route 23/74 in North Carolina. RCUT intersections are most utilized at intersections with heavy highway left turn volumes and low/medium minor road volumes (Bared, 2009b).



1.6.6 Other Considerations

Whether signalized or unsignalized, the cost of an RCUT often is comparable to an equivalent conventional design. However, compared to a full, grade-separated interchange, RCUTs are much less costly, have fewer impacts, and can be constructed in a fraction of the time

The RCUT is an effective way for an agency to balance providing local access to the major road with the need to deliver safer, more efficient projects. Access to local businesses and commercial areas can be maintained because the U-turns accommodate all movements. When signalized, RCUT designs provide great flexibility in traffic signal timing to accommodate unbalanced traffic flow resulting from commuter patterns or retail developments (Inman and Haas, 2012).

RCUT designs accommodate pedestrians and bicycles through channelization that creates effective refuge islands for pedestrian crossings and bicycle queuing areas.

1.6.7 Best Practices

RCUT (US 15, Frederick County, MD)

Located in a rural area, US 15 is a four-lane divided highway that intersects numerous two-lane minor roads. Before conversion, drivers found it difficult to judge left-turn and through movements at these intersections, resulting in high levels of fatal and injury crashes. The solution was to install a series of six RCUTs between Frederick and Emmitsburg in Frederick County. After construction of the RCUT:

- Injury and fatal crashes decreased by 40 percent and 70 percent, respectively. Property damage crashes decreased by 20 percent.

RCUT (NC 55 Bypass, Holly Springs, NC)

Traffic on an already heavily traveled mixed use corridor was expected to more than double within just a few years due to additional growth and the opening of a new interchange. A series of four Restricted Crossing U-Turn intersections along the corridor was implemented. Results showed:

- Reduced travel times on the main roadway
- Reduced number of potential conflict points, benefitting both motorized and non-motorized traffic
- Ability to handle increasing traffic for the next 20 years
- Innovative design solution funded with private investment in the form of a public-private partnership between NCDOT and a local developer.

RCUT (US 17 Corridor, Wilmington, NC)

Conventional intersections along a major access route in coastal North Carolina were operating at maximum capacity, unable to support the mobility, safety, and economic development needs



of the region. A series of six Restricted Crossing U-Turn intersections along a major regional arterial highway provided the following outcome:

- Reductions in travel time—25 percent during peak hours and 20 percent overall.
- Reductions in crashes—an average of 46 percent in total crashes and an average of 63 percent in injury crashes.
- Innovative design solution funded with private investment in the form of a public-private partnership between NCDOT and regional developers.

1.7 Quadrant Roadway Intersection (QRI)

1.7.1 Introduction

The Quadrant Roadway Intersection (QRI) is an unconventional intersection design that effectively accommodates high traffic volumes while eliminating the conventional left turns. Safety has been a significant concern in conventional intersections with high turning volumes; QRI are trying to improve safety at these locations. The Quadrant Roadway intersection is predominantly used at intersections with two busy suburban or urban roadways. U-turns are not allowed at the main intersection and must be rerouted in a fashion similar to left turns as shown in Figure 11.

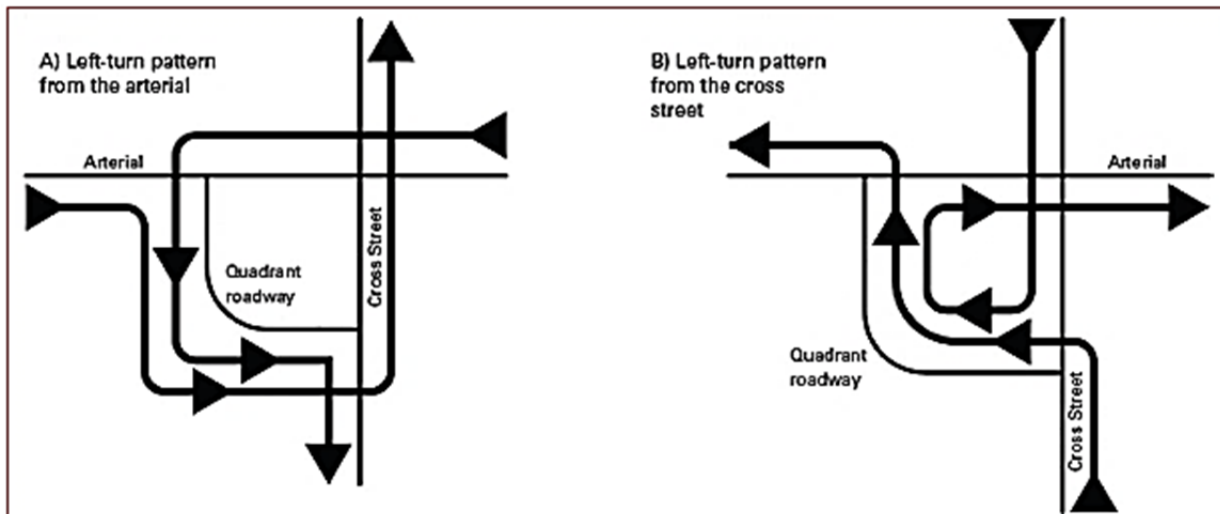

Figure 11: Movements in a QRI

1.7.2 Operation

Reid (2000) studied the operations, design, advantages and disadvantages of the QRI method. The QRI uses an additional roadway to eliminate direct left turns from the main road at one quadrant of the intersection. The roadway should have at least three lanes to work efficiently and facilitate left turns. There is no specific quadrant that must be chosen, any of the four quadrants on the intersection would work properly. All the left turns on the main intersection are rerouted to the quadrant roadway. At a QRI, the main intersection has the capability of operating with two phase signals as shown in Figure 12 (Reid, 2000).

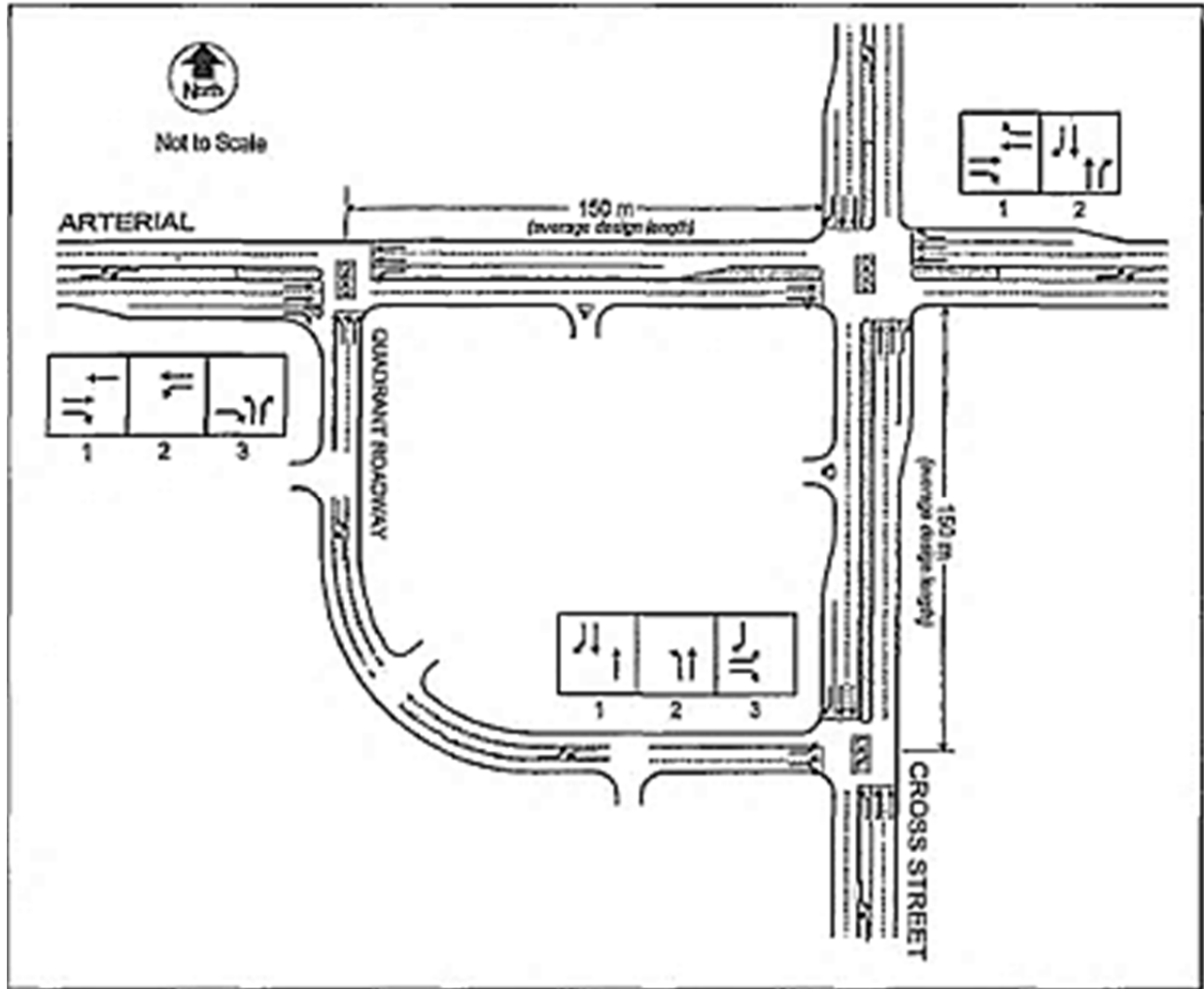

Figure 12: QRI Design

Westbound Left Turns:

- All vehicles trying to make a left turn will pass the main intersection and turn left onto the quadrant roadway.
- Make a right turn onto the cross street

Eastbound Left Turns:

- All vehicles trying to make left turns will turn right onto the quadrant roadway.
- Turn left on the cross street and pass through the main intersection.

Northbound Left Turns:

- All vehicles trying to make left turns will turn left onto the quadrant roadway.
- Turn left at the end of the QR onto the main road.

Southbound Left Turns:



- All vehicles trying to make left turns will pass the main intersection and turn right onto the quadrant roadway.
- Turn right at the end of the QR onto the main road.
- Pass through the main intersection again.

The QRI has three intersection signalizations that must be coordinated in order to have a well flowing traffic and intersection. They must work together in order to have an efficient control system. As mentioned above the main intersection has a two phase signal and the other two intersections have a three phase signal. The offset of the two intersection signals allow perfect movement through the main intersection. The additional phase on the other two signals does not negatively affect through movements.

1.7.3 Analysis

Reid analyzed QRIs and conventional intersections through CORISIM software. The major variables utilized in testing were the turning movement percentages, volume levels, and directional splits. The two designs being analyzed were constructed with an identical external node coordinate system. The consistency in both test allowed for an accurate comparison of the performance measure between the QRI and conventional intersection. Different measures were tested. These include queuing, stops, and delays.



1.7.4 Performance Measures

The results comparing both the conventional and QRI design can be seen in Table 12 below.

Table 12: System MOEs by Geometric Design

Measure	Conventional	QR Intersection	Percent Difference
Cycle length (s)	142	90	-58
System delay (veh-h)	35.8	24.4	-46
System travel time (veh-h)	66.9	58.2	-15
Stops/vehicle	0.71	0.78	+9
Speed (mi/h)	23.4	27.2	+14
Maximum queue (veh)	23.4	12.4	-88
Westbound left-turn travel time (s/veh)	120.9	125.6	+4
Eastbound through travel time (s/veh)	86.6	66.5	-30
Main intersection delay (s/veh)	41.2	13.5	-215
Main intersection LOS	E	B	Not relevant

Design type	Average cycle length (sec)	System delay time (veh-hrs)	System travel time (veh-hrs)	Average stops/veh	Average speed (mph)	Average maximum queue (veh)	WB left-turn travel time (sec/veh)	EB thru travel time (sec/veh)	Intersection average delay (sec)	LOS
Conventional	141.9	35.8	66.9	0.71	23.4	23.4	120.9	86.6	41.2	E
Quad Roadway	90.0	24.4	58.2	0.78	27.2	12.4	125.6	66.5	13.5	B
<i>% Difference</i>	<i>-58%</i>	<i>-46%</i>	<i>-15%</i>	<i>9%</i>	<i>14%</i>	<i>-88%</i>	<i>4%</i>	<i>-30%</i>	<i>-215%</i>	

- It was concluded that the QRI design had 58 percent shorter average cycle length.
- The conventional average cycle length was about 142 seconds.
- The QRI average cycle length was about 90 seconds.
- QRI showed reduction in travel time and queuing.
- In the QRI design, travel time was reduced by 15 percent; delay time was reduced by 46 percent and through travel time was reduced by 30 percent.
- The average of the QRI's longest queue lengths are 88 percent shorter than the conventional intersection's queue lengths.
- Overall when purely analyzing the results through design, the QRI was more effective and efficient than the conventional intersection design.



QRI main advantages and disadvantages when compared to the conventional intersection:

Advantages

- Ease of progression in the main intersection due to the two phase signal
- Total system delay is reduced
- Queuing is reduced
- The number of conflict points at the main intersection are reduced
- Possible reductions in head on collision due to left turns
- Reduction in vehicle clearance and pedestrian crossing times due to narrower intersection widths
- 4-lane and 5-lane cross-sections could be used for the connector

Disadvantages

- Left turn travel distance is increased
- Possible increase in left turn stops and travel time
- Driver confusion
- Unacceptance of the new alternative and left turn options
- Additional signalization
- Extra right of ways will be needed for the QR
- Access to local parcels is affected by the location and design of the connector
- U-turns are prohibited at the main intersection

1.7.5 Further Studies and Reports

Reid recommended a spacing of 500 feet from the main intersection to the secondary intersections. Pedestrians will need to cross an additional street when using the QRI. The pedestrians that walk through the main intersection crosswalks walk a shorter distance. An additional benefit to pedestrians will be the shorter cycle lengths at these new alternative intersections.

Bared (2009a) also studied the QRI alternative using VISSIM to compare the performance of the QRI and the conventional intersection. Four QR and conventional designs were tested under four different volume scenarios. The testings concluded that there was a 5 to 15 percent increase in travel time for left turning traffic while a reduction of 5 to 20 percent in travel time for throughput traffic when compared to the conventional intersection. Safety data was not available in this report due to the lack of existing Quadrant Roadway intersections in the US. The QRI has a lower amount of conflict points when compared to the conventional intersection. The conventional intersection has 32 conflict points while the QRI has 28 conflict points. It can be assumed that the QRI is the safer approach due to the amount of conflict points when compared to the conventional intersection. QRIs work most efficiently when there are heavy left turns and through volumes. A ratio of 0.35 or lower is effective when analyzing the minor road total volume to the total intersection volume. A clear disadvantage of the QRI can be the cost of building the connecting quadrant roadway (Bared, 2009a).



1.7.6 Best Practices

QRI (State Route 4 at State Route 4 Bypass (4B) and Ross Road, Fairfield, OH)

Located in City of Fairfield, Ohio. The intersection of the Bypass with State Route 4/Ross road is modified to utilize a new Quadrant Roadway Intersection, which split the traffic between multiple intersections, improving the flow of traffic. The benefits of this QRI are:

- Acceptable design year LOS
- Increased safety through reduced congestion
- Allow for maximized regional mobility without eliminating existing development and maintaining future development options

1.8 Roundabouts

1.8.1 Introduction

Roundabouts are the last form of the innovative alternative intersection designs analyzed in this literature review. Roundabouts are implemented to remove direct left turns and traditional signalizations. These alternative intersections have shown to be safer approaches to pedestrians and drivers. Traffic moves along the lanes surrounding the central island. The main movement is right turn at the roundabout entry or leg as shown in Figure 13.

1.8.2 Operation

Roundabouts are circular roads that contain various openings to enter the path. Majority of the roundabouts have single or dual lanes. They are different from traffic circles and rotaries. Vehicles will approach the roundabout from all directions as seen in Figure 7.0. Before a vehicle enters the roundabout, it must yield to the circulating traffic and then proceed with caution when there is sufficient gap. The vehicles circulating the roundabout have the right of way and all cars entering must yield as shown in Figure 13.

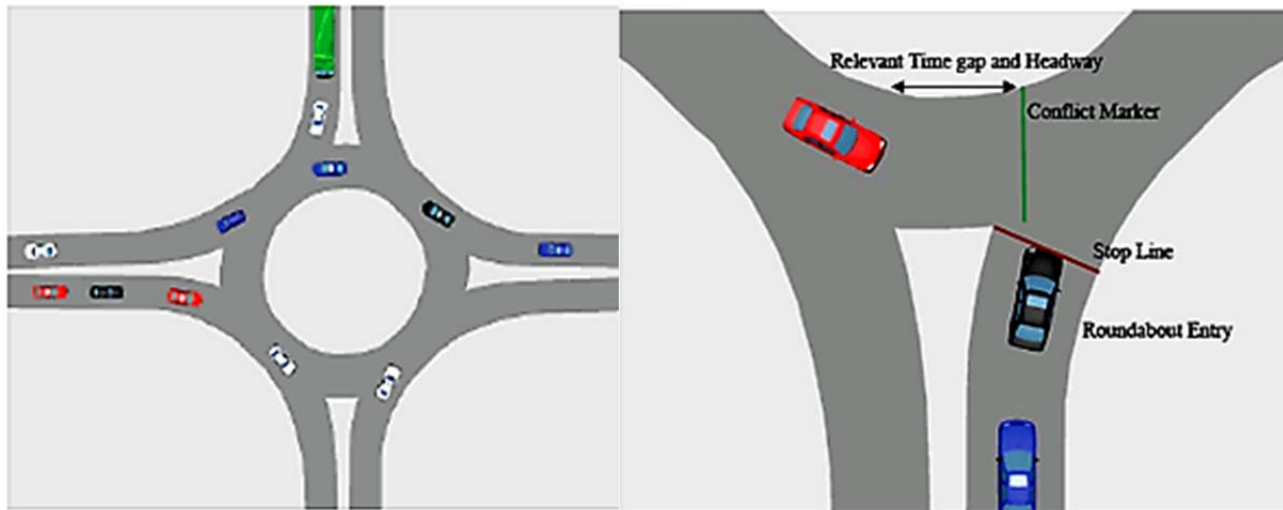

Figure 13: Single Lane Roundabout with Priority Movements

1.8.3 Analysis

(Bared and Edara, 2005) used VISSIM to analyze the roundabout performance. VISSIM is also known as one of the simulation based programs that can truly model roundabouts. VISSIM results are compared with results from two other simulation based programs. The first is RODEL which focus on creating empirical models and the second is SIDRA which focuses on creating analytical models. The empirical models are based off regressions of existing roundabout data. VISSIM simulated two urban roundabouts, one with a. The stop line is utilized to control vehicle's capability of entering the roundabout. It depends on the gap time and headway at the conflict marker. Gap time is defined as the time an approaching vehicle will take to reach the



conflict marker. Minimum headway is the length of time between the first vehicle approaching and the following vehicle to use the same gap. VISSIM was utilized to compare the replacement of a signalized intersection with a dual-lane roundabout on an arterial.

1.8.4 Performance Measures

Data was collected at 22 locations around the U.S. based on ADT volumes, crash, geometry, video, and speed data for analyzing capacity. There were 15 roundabouts analyzed that were single-lane and seven roundabouts that were dual-lane. With regards to comparison between the three software packages mentioned earlier, field data and VISSIM simulation output data can be seen below on Tables 13 and 14. Although the single and dual VISSIM simulations had lower capacities compared to the other simulation programs, it showed comparative results to field data on existing roundabouts (Bared and Edara, 2005).

Table 13: Single Lane Roundabout – Comparison of VISSIM Results with Field Data

Observation No.	Conflicting Flow (veh/hr)	Maximum Entry Flow (veh/hr)	
		Real Data (veh/hr)	VISSIM (veh/hr)
1	120	1020	1250
2	300	852	930
3	480	690	700
4	600	588	550
5	720	480	400
6	900	312	290

Table 14: Dual Lane Roundabout – Comparison of VISSIM Results with Field Data

Observation No.	Conflicting Flow (veh/hr)	Maximum Entry Flow (veh/hr)	
		Real Data (veh/hr)	VISSIM (veh/hr)
1	300	1620	1800
2	600	1290	1350
3	900	990	1000
4	1200	750	700
5	1500	552	450
6	1800	372	300

With regards to comparison between the roundabout alternative and the conventional intersection, it was concluded that roundabouts outperform signalized intersections in most cases. The average queue and delay were lower for the roundabout in most cases. However, roundabouts near operating capacity aren't as efficient.

1.8.5 Further Studies and Reports

Retting et al. (2001) analyzed conflicts, crashes, and their severity at roundabouts around the United States and compared roundabouts to conventional signalized intersections. Roundabouts are commonly used around the world, but they have not reached the same popularity in the



United States. Older rotary systems were not efficient due to their high speeds. Drivers tended to enter the system at speeds of 30 mph or more. Modern day roundabouts are designed for speeds of approximately 15 mph. International studies show that replacing conventional intersections with roundabouts have a high impact in crash reductions. Although these studies show positive results, they do not control regression-to-the-mean effects. This absence of information can greatly affect the validity of these studies.

Before and after study was conducted on various roundabouts to analyze crash reductions in these alternatives and to account for the regression-to-the mean effects. The empirical Bayes approach was utilized. 24 roundabouts were analyzed in the following eight states, Colorado, California, Florida, Kansas, Maine, Maryland, South Carolina, and Vermont. 15 of the roundabout analyzed were single lane and the other nine were multilane. The data was gathered through report summaries and most importantly police crash reports. The injury severity was rated by the police using the KABCO scale or by distinguishing them through three categories (Retting et al., 2001).

KABCO:

- K= Killed
- A=A injury
- B=B injury
- C=C injury
- O=Only property

Three Injury Categories:

- 1- Possible injury (Not accounted for in this study)
- 2- Nonincapacitating injury
- 3- Severe incapacitating injury

The empirical Bayes approach estimated a reduction in all crashes by 38 percent. It also estimated a reduction in the number of injury crashes by 76 percent. The four roundabouts in Vail, Colorado had no data before the conversion started so the injury estimates were based on the other 20 intersections. Some the intersections might show low to nearly zero benefits after converting the intersection into a roundabout. Every intersection has its unique characteristics, in some cases the existing intersection was already a safe approach and in other cases it was hard to adjust the deflections and speed reductions. Although attaining data on fatal/incapacitating crashes was difficult, the attained data showed reductions in these form of crashes. The reduction in fatal and incapacity injury crashes was estimated to be 89 percent. The crash analysis can be seen on Table 15.

Before and after injuries on converted intersections:

- | | |
|--|--|
| <ul style="list-style-type: none"> • Fatal injuries: <ul style="list-style-type: none"> ○ Before – 3 ○ After – 0 • Incapacitating injuries: <ul style="list-style-type: none"> ○ Before – 27 ○ After – 3 | <ul style="list-style-type: none"> • Pedestrian injuries: <ul style="list-style-type: none"> ○ Before – 4 ○ After – 1 • Bicyclists injuries: <ul style="list-style-type: none"> ○ Before – 4 ○ After – 3 |
|--|--|



Table 15: Before and after Crashes at Roundabouts

Group Characteristic Before Conversion and Jurisdiction	No. of Crashes During Period After Conversion		Crashes Expected During After Period Without Conversion (SD)		% Reduction in Crashes	
	All	Injury ^a	All	Injury ^a	All	Injury ^a
Single lane, urban, stop controlled						
Bradenton Beach, Fla	1	0	9.9 (3.6)	0.0 (0.0)		
Fort Walton Beach, Fla	4	0	16.9 (3.9)	2.7 (1.1)		
Gorham, Me	4	0	6.8 (1.4)	0.9 (0.4)		
Hilton Head, SC	9	0	42.8 (6.0)	8.2 (1.9)		
Manchester, Vt	1	1	1.7 (0.7)	0.0 (0.0)		
Manhattan, Kan	0	0	4.2 (1.2)	1.2 (0.5)		
Montpelier, Vt	1	1	4.3 (1.8)	1.1 (0.6)		
Santa Barbara, Calif	17	2	17.97 (4.9)	0.0 (0.0)		
West Boca Raton, Fla	7	0	8.1 (3.0)	2.6 (1.3)		
Entire group (9)	44	4	112.6 (10.2)	16.6 (2.6)	61	77
Single lane, rural, stop controlled						
Anne Arundel County, Md	14	2	24.6 (4.0)	6.2 (1.7)		
Carroll County, Md	4	1	15.2 (2.6)	3.2 (0.9)		
Cecil County, Md	10	1	14.3 (2.9)	5.6 (1.4)		
Howard County, Md	14	1	36.7 (5.5)	7.7 (2.1)		
Washington County, Md	2	0	14.4 (3.1)	4.2 (1.3)		
Entire group (5)	44	5	105.2 (8.4)	26.9 (3.4)	58	82
Multilane, urban, stop controlled						
Avon, Colo	3	0	19.9 (4.9)	0.0 (0.0)		
Avon, Colo	17	1	12.2 (3.1)	0.0 (0.0)		
Vail, Colo	14	...	19.1 (4.4)	...		
Vail, Colo	61	...	50.9 (7.6)	...		
Vail, Colo	8	...	9.8 (2.1)	...		
Vail, Colo	15	...	11.8 (2.3)	...		
Entire group (6)	118	...	123.7 (11.0)	...	5	...
Urban, signalized						
Avon, Colo	44	1	49.8 (7.0)	5.4 (1.7)		
Avon, Colo	13	0	30.1 (5.7)	2.3 (1.0)		
Avon, Colo	18	0	52.1 (7.0)	5.3 (1.7)		
Gainesville, Fla	11	3	4.8 (1.5)	1.3 (0.5)		
Entire group (4)	86	4	131.7 (10.9)	15.0 (2.7)	35	74
All conversions (24)	292	14	472.6 (20.4)	58.5 (5.1)	38	76

Overall the conversion from conventional intersections to roundabouts showed significant reduction in crashes. Large crash reductions were seen in fatal or incapacitating injuries. The roundabout also showed great reductions in property damage. The crash reductions in the roundabout approach are due to reduced speeds and the elimination of specific vehicle conflicts. Left turn conflicts, front to rear conflicts, and right angle conflicts are all prime examples of specific vehicle conflicts. These conflicts result in two thirds of the conflicts reported to police on urban arterials. It also appears that this new alternative has no significant effect on elderly driving people. Land can be saved when building a roundabout instead of a small conventional intersection. Busy urban intersections may not be great locations to have roundabouts due to their capacity restrictions and lack of right of ways. Roundabouts are also not effective at intersections with high volumes of vehicles, pedestrians and bicyclists. Although roundabouts are not appropriate for all intersections, they have shown to increase safety and outperform conventional intersections in many scenarios.



1.8.6 Best Practices

Roundabout (Lisbon, Maryland)

This roundabout is located in the town of Lisbon, Maryland, in a rural environment, which is a single-lane roundabout at the two state highways (Maryland Routes 94 and 144). The AADT on the major road is 6,700 and on the minor road 4,200. This roundabout replaced a cross intersection regulated by a two-way flashing red beacon. The geometry is relatively simple, with an inscribed diameter of 30.5 m (100ft) and with entry and circulating widths of 5.5m (18 ft). A truck apron of 3.6 m (12ft) surrounds the landscaped, raise portion of the central island. The benefits of this roundabout are:

- Total accident rates decreased from an average of 7.4 accidents per year to 1.4 accidents per year.
- Total delay decreased from 1.2 vehicle hours to 0.34 vehicle hours in the morning peak hour and from 1.09 vehicle hours to 0.92 vehicle hours in the afternoon peak hour, an overall reduction of 45%.

Roundabout (I-70/Vail Road Interchange Roundabouts in Vail, Colorado)

This roundabout is built in 1995, which is the first two-roundabout interchange in the United States. It replaced stop-controlled intersections that needed the assistance of traffic officers directing traffic during the seasonal peaks. It included a raindrop roundabout with an inscribed diameter of 37m at the northern side of the interchange and a regular roundabout with an inscribed diameter of 61 m at the southern side.



II- DEVELOPMENT OF PERFORMANCE MEASURES AND EVALUATION MATRIX

2.1 Continuous Flow Intersections (CFI)

2.1.1 Area Type and Roadway Conditions

The CFI is best suited for intersections with moderate to heavy traffic volumes, especially to those with very heavy or unbalanced left-turn volumes at urban or suburban areas. It is also known as Crossover Displaced Left-Turn (XDL) intersection. The existing locations where these alternatives are implemented are regularly used by pedestrians and bicyclists. This alternatives are usually applied as retrofits of conventional at-grade intersections that are operating at or beyond capacity. The CFI is a competitive alternative to a full, grade-separated interchange. Some of the situations where a CFI intersection may be suitable are as follows:

- If the volume-to-capacity ratio (v/c) is greater than 0.8 on two opposing approaches.
- If the cross product of left-turn and opposing through vehicles is greater than 150,000 on two opposing intersection approaches.
- If left-turning volume is greater than 250 veh/h/lane and opposing through volume is greater than 500 veh/h/lane on two opposing intersection approaches.
- If an intersection is heavily congested with many signal phase failures.
- If left-turn queues at an intersection spill beyond the left-turn storage bays.

2.1.2 Right of Way

CFI's footprint is somewhat larger than conventional intersections and may result in wider streets at some locations but require less right of way than interchanges or partial grade-separation. Signalized bays are used to allow vehicles to cross onto the opposing through lanes. Wider medians may be required with this alternative at the signalized bays but could be tapered back to the original width at the main intersection. The applied medians are 10 ft long by 10 ft wide and are used as refuge for pedestrians. Refuge islands must be large enough to accommodate bikes, strollers, and pedestrians. Bicycle boxes can be placed in front of the far-side refuge to allow for two-stage left turns. Four legged CFI intersections can have four displaced left turns, known as full CFI, or two displaced left turns on the major street, known as partial CFI. The CFI can have single or dual left-turn crossover lanes and two to three through lanes per direction. Lane widths are usually wider for through tangent roadways than tangent sections. Designers should study the use of path alignment through the signal to position vehicles at the stop bars. Cross slopes may be provided at the crossover intersection. Left turning vehicles shift from a 2% slope at the outside over to a 2% slope at the other side of the road through S-curves. The spacing between the upstream crossover and the main intersection ranges from 300 to 600 feet, Maryland depending on the demand.

Access management is very important when considering new alternatives. Frontage roads and other access treatments can provide access to businesses and homes near the CFI. The AASHTO Green Book provides specifications on frontage roads. CFIs tend to restrict access to parcels



located in the quadrants of the main intersection. In order to allow access to these parcels right in/right out configurations from the channelized right turn lanes can be implemented. In order to accommodate vehicles coming out of driveways, U-turn crossovers can be provided between the main intersection and the left turn crossover. Driveways between the weaving and merging areas need to be avoided to prevent deceleration and rough maneuvers.

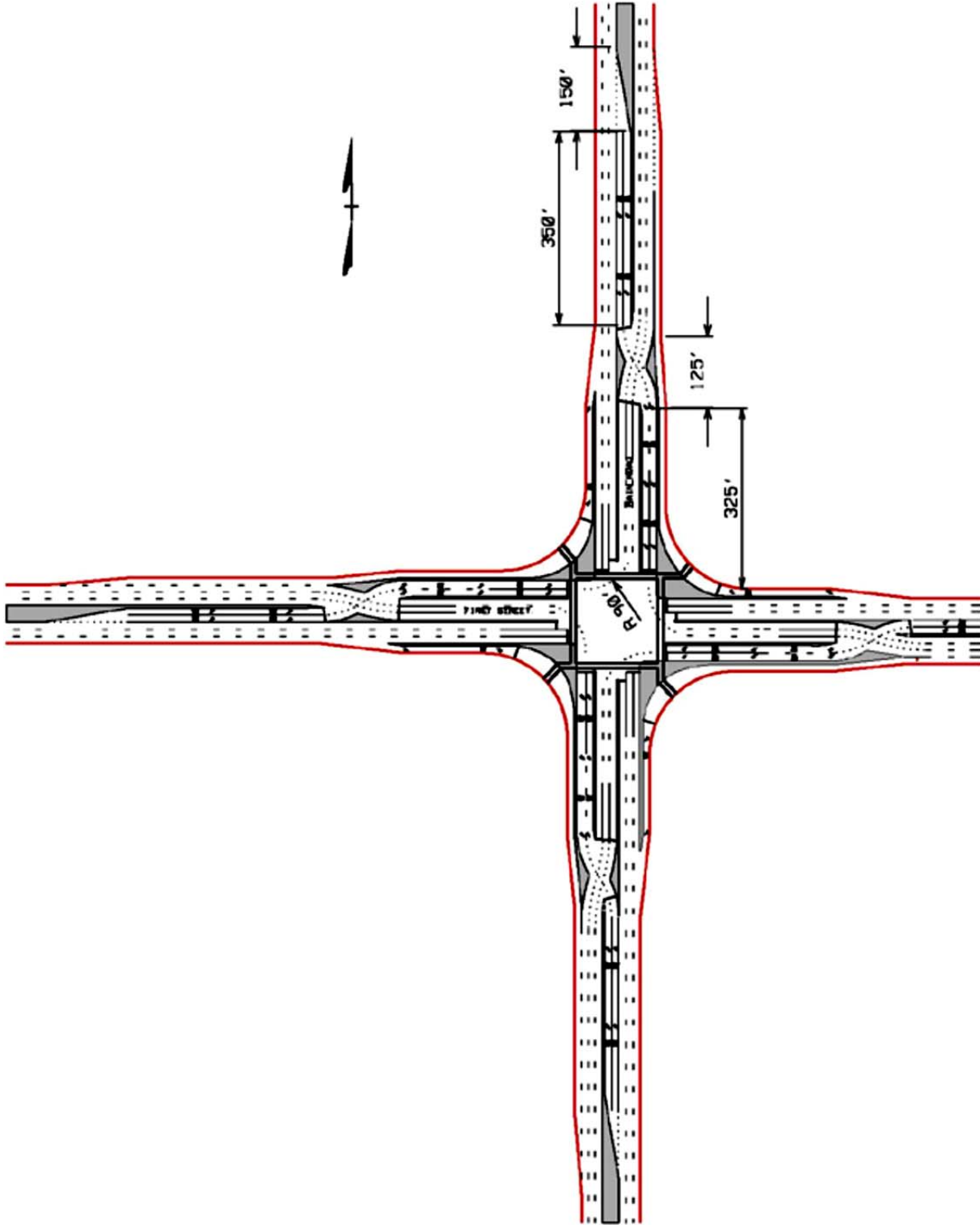

Figure 14: Typical Full CFI Intersection

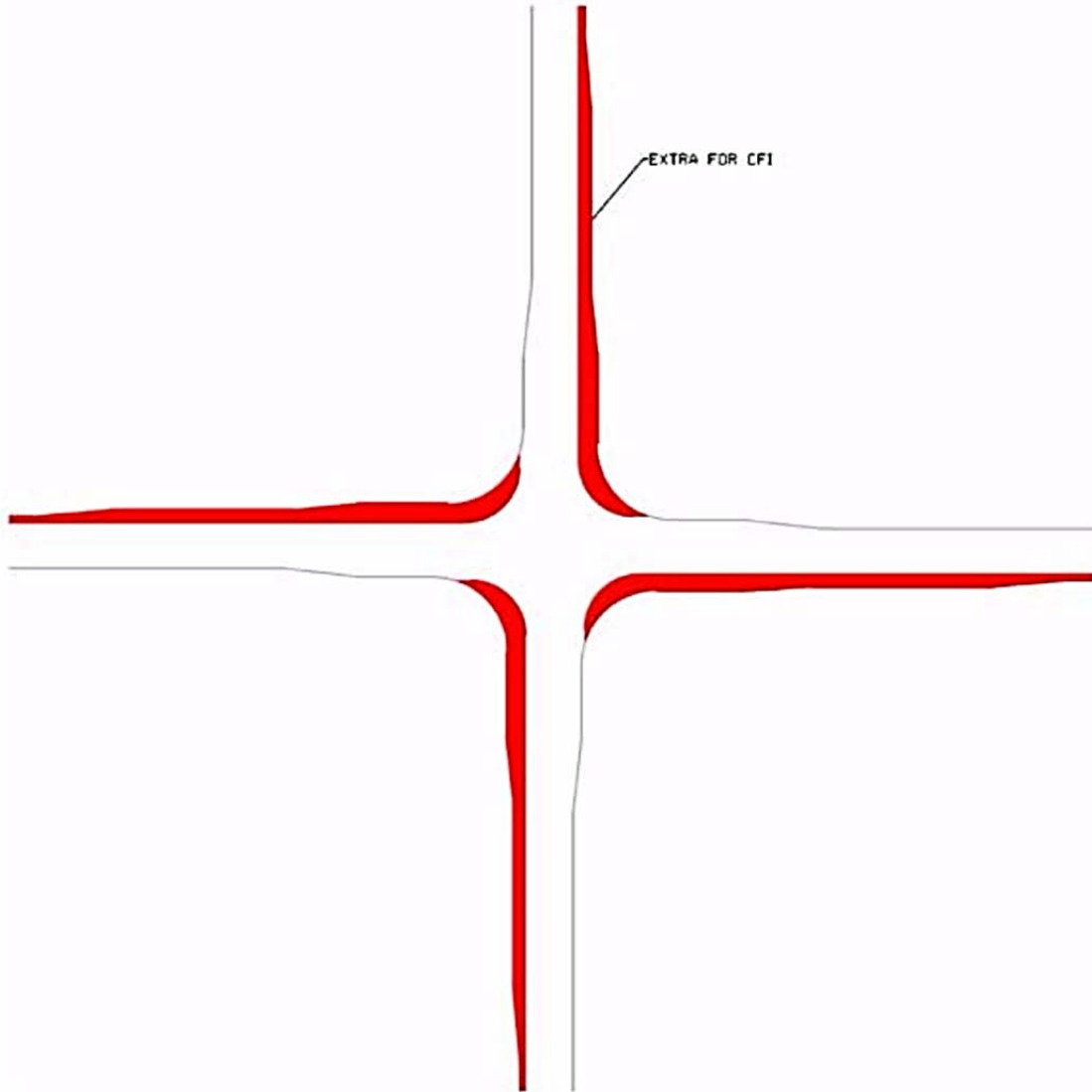

Figure 15: Typical Footprint for CFI Intersection

2.1.3 Pedestrian and Bicyclist Interaction

Pedestrian crossing times have to be optimized in order to achieve true benefits. Wider streets cause longer pedestrian crossing distances and increase the time it takes for bicyclist to ride through. Pedestrian islands provide refuge along the crosswalks between the crossover left turns and through lanes. Crosswalks allow pedestrians to move from the channelization to the outer portion of the intersections. These crosswalks across the channelized right turns can be implemented with or without signals. If multiple right-turn lanes are provided at the intersection then the crossing should be signalized. There are two ways to operate and control pedestrian crossings:

- 1- Use signals at channelized right turns to ease the crossing of the right turn lanes. The pedestrians continue on to the first refuge island that is located between the crossover left

turns and the through lanes. During pedestrian phases, pedestrians proceed to the opposing side of the road. (Note: Right turn on red are prohibited in this case)

- 2- The displaced left turns can yield to pedestrians using the crosswalk. This will allow the pedestrians to cross in one stage. However it is not a recommended practice.

Accessibility to pedestrians with disabilities and vision and/or mobility impairments should be accounted for. The Americans with Disabilities Act (ADA) and the Public Right-of-Way present policies and guidelines for intersections that accommodate all pedestrians. Pedestrian walkways must be delineated through landscaping, curbing, or fencing in order to accommodate vision-impaired pedestrians. Reasonable slopes should be provided for wheelchair users and strollers. Curb ramps and detectable warning surfaces at the edge of sidewalks should be provided. Locator tones and audible speech messages need to be provided at pedestrian signals to assist blind pedestrians. Push buttons need to be accessible by wheelchairs. The crosswalk widths should be wide enough to allow pedestrians and wheelchairs to cross without delays.

DXLs allow the option of using bicycle paths with separate lanes or shared used paths. Right turning vehicles and bicycles typically share the travel lanes. However, bicycle lanes or bicycle boxes may be utilized to prevent conflicts between bicyclist and right turning vehicles. The three ways bicyclist can complete left turns on this alternative are:

1. Using the traffic lanes as passenger cars to make the turns.
2. Using bicycle ramps on sidewalks or shared paths on the cross walks.
3. Using a bicycle box in front of the far side refuge. This refuge island will be located between the through and displaced left turn lanes which are a two-stage crossing.

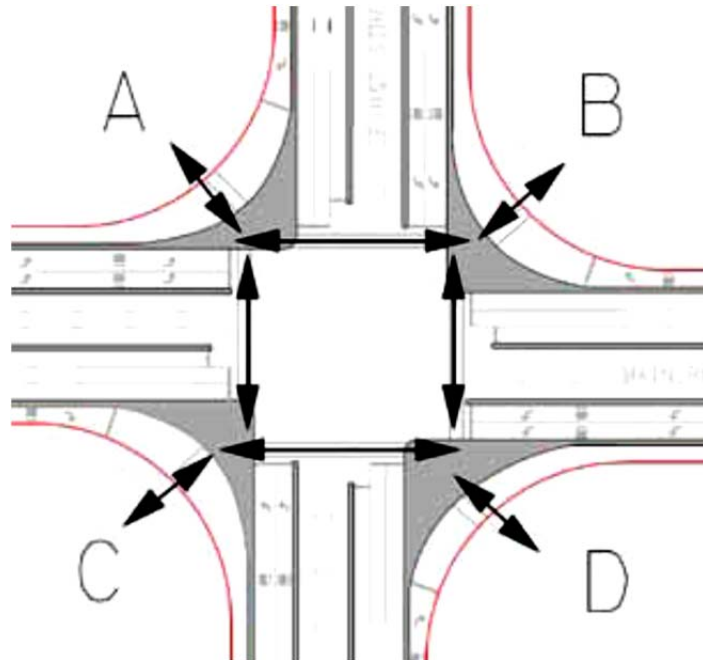

Figure 16: Typical Pedestrian Movements at CFI Intersection



2.1.4 Wayfinding

Wayfinding is highly needed due to the complexity of the alternative designs. Appropriate lighting must be used at intersections for pedestrian and bike safety. Green stripes on pavement can be implemented to indicate bicycle continuation lane. Wrong way warning signs, stop bars, curb lines, and pavement markings need to be utilized to avoid confusion and promote safety. Left turning signs are needed in advance to remind drivers about the lane crossover. Since these left turn pockets for the crossover are positioned well in advanced, signs must communicate with the vehicles to position themselves in the proper lane(s). Lane extension striping should be utilized to guide vehicles through the main and crossover intersections. It was also found that the words “KEEP CLEAR” on the pavement markings beyond the minor street stop bar prevent stop bar overruns.

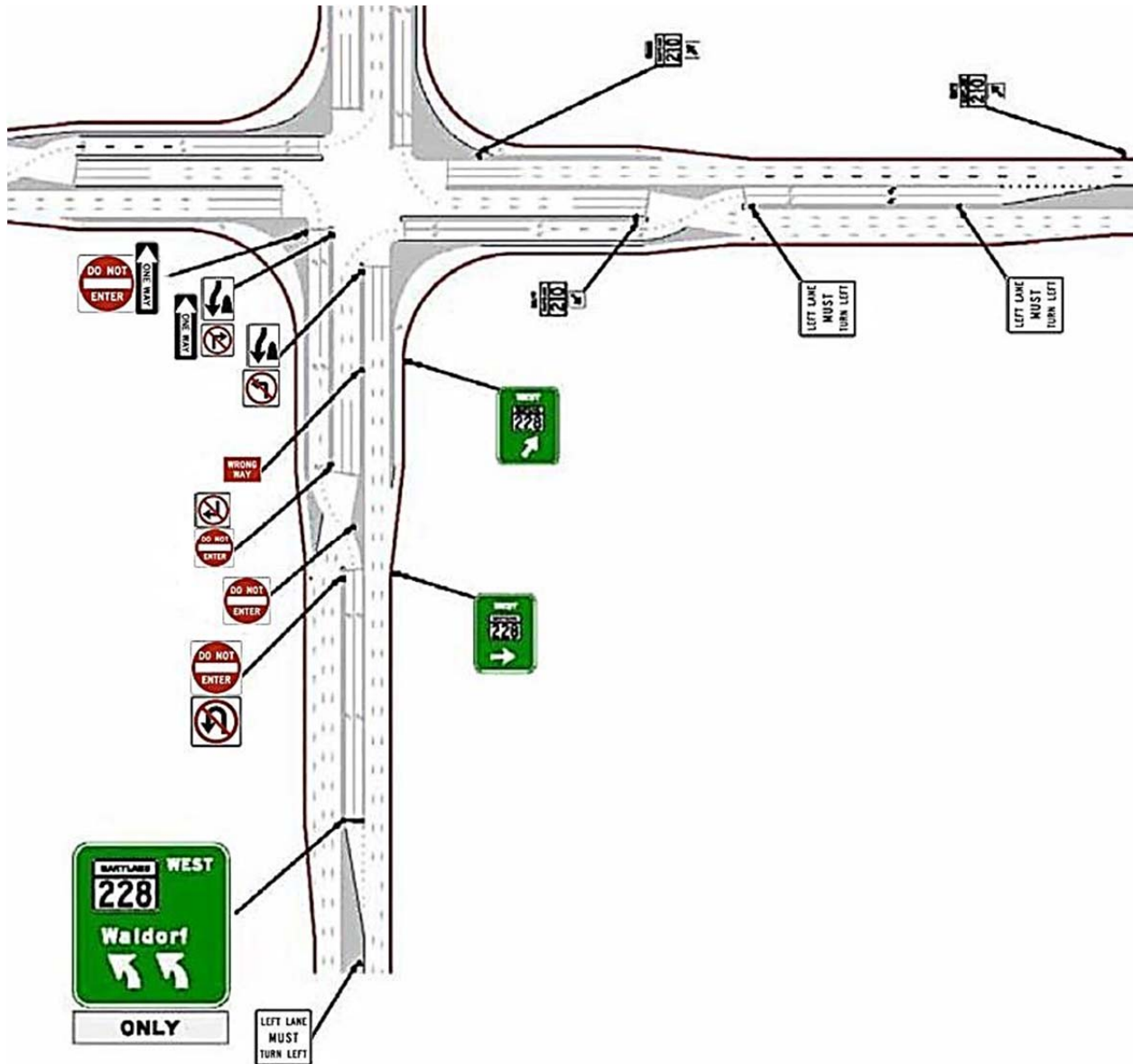

Figure 17: CFI Signing and Marking (Maryland Practice)

2.1.5 Signalization

Additional signalization is provided at the secondary intersections to allow vehicles to crossover to the opposing side. CFI operates as two phase signal with short cycle lengths. Two phase signals provide flexibility for progression and lead to reduced delays and shorter queues. Optimal cycle lengths are typically between 60 and 90 s. At a partial CFI intersection that handles minor road left turns at the main intersection, the signal control at the main intersection operates with three signal phases and cycle lengths are typically between 80 and 110 s. Signalized right turns as part of the crossover signal can eliminate downstream weaving and merging problems. Intersection spacing influences signal phase time for left turns. CFI can consist of up to five signalizations that are controlled by separate controllers or a single controller. The crossover upstream of the main intersection for the left turning vehicles may have a green light at the same



time as the minor street movements are occurring. In regards to left turn crossovers, offset length determines the max signal phase length. Using pedestrian signals at channelized right turns can ease the pedestrian crossings. At the CFI, efficiency in signal operation is achieved by simultaneously providing safe passage for left turns and through movements from opposing approaches. This is achieved by displacing left turns to the outside of conflicting through movements in advance of the intersection and reallocating green time to heavier through movements. Another component of the efficiency gain at the CFI is to ensure that the left turn signal at the main intersection turns green as the vehicles approaching from the upstream crossover signal arrive at the main intersection.

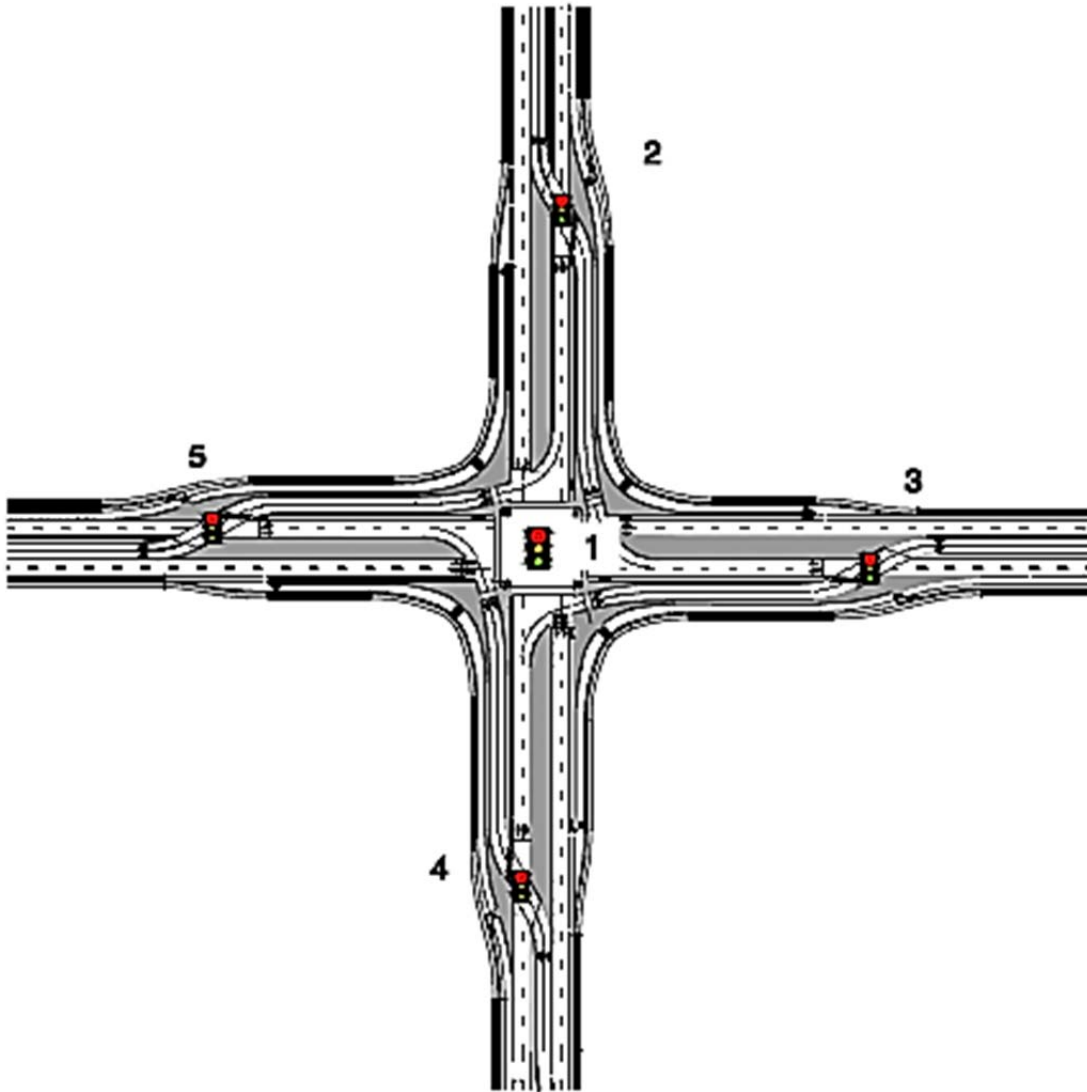

Figure 18: Typical CFI Signal Locations

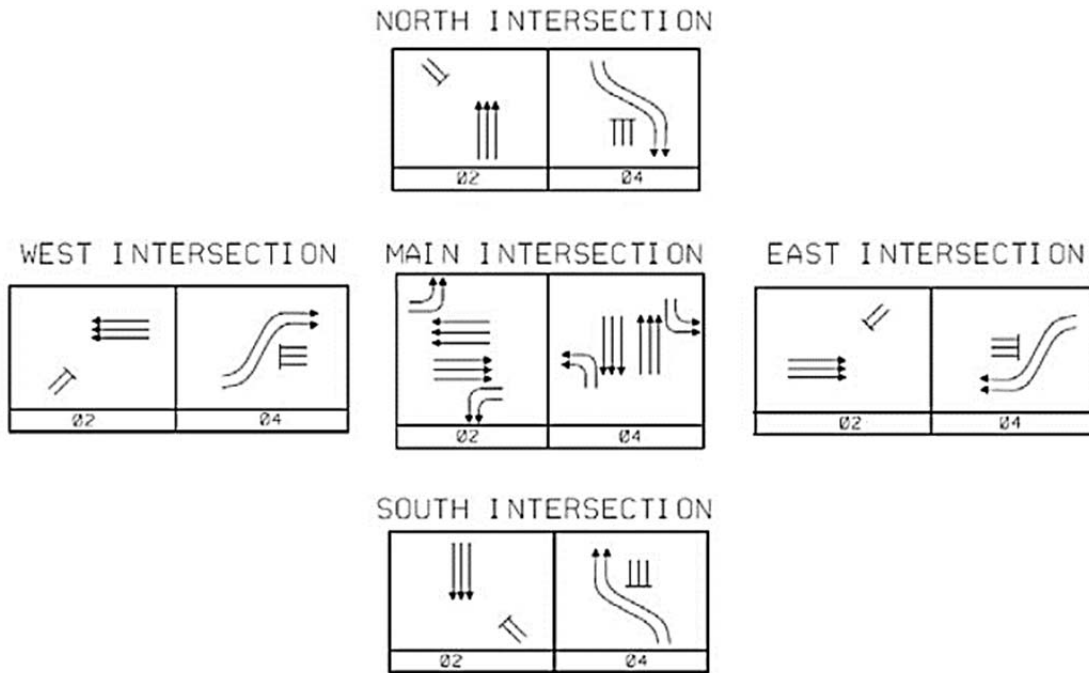

Figure 19: Typical 2-Phase Signal Operating Plans at CFI

2.1.6 Benefit-to-Cost Ratio

CFI intersections proved to have high benefit-to-cost ratios. Construction costs are reduced by 20-40 million dollars. Most drivers that experienced driving through a CFI had positive feedback to the alternative and felt comfortable with the new approach. In some locations, higher costs were incurred due to right of way required for channelized right turns. When compared to conventional intersections, CFIs may be more expensive due to the extensive street layout, traffic control devices, and larger footprints. However, a CFI is more cost effective than a grade separation. Several CFIs have been built around the United States and their costs were analyzed below:

- 1- Location: Airline Highway/ Siegen Lane Intersection. Baton Rouge, Louisiana
Year: 2006
Cost: Approximately \$4.4 million (Bid)
- 2- Location: Bangerter Highway/ 3500 South Intersection. Salt Lake City, Utah
Year: 2007
Cost: \$7.5 million (Total project cost)
- 3- Location: Route 30/ Summit Drive Intersection. Fenton, Missouri
Year: 2007
Cost: \$4.5 million (Bid)

Grade separated arterials cost around 10 to 30 million dollars to construct. As seen from the three CFIs built above, the average cost is between 4 to 8 million dollars. CFIs are a cheaper alternative that offer various benefits to pedestrians, bicyclist, and vehicles.



2.1.7 Performance Measures

Under balanced volumes, increasing the distance between primary and secondary intersection increases capacity, but increases low volume delays. CFI displays lower delays, lower left turn delays, and higher capacities when compared to conventional intersections. CFI's capacity was about 90% higher than the capacity of conventional intersections. In general, the CFI outperforms the conventional intersection. The CFI works efficiently at locations where right of way is not a problem. Fuel and emissions decrease on CFIs. Some other benefits of the CFI are:

- Average speed on the intersection increases by 13-30 percent
- Energy savings of 5-11 percent
- HC, CO, and NOx emissions decreased by 1-6 percent
- Fewer and less severe crashes
- Improved level of service
- Capacity along the corridors can increase by 20-50 percent



2.2 Median U-Turn (MUT)

2.2.1 Area Type and Roadway Conditions

The MUT is an excellent choice for locations with moderate to heavy volumes of through traffic and moderate left turns. It also works best at areas where volumes on the main line are high and the cross-street volumes are low, predominantly at urban or suburban intersections and also rural corridors. This design has been used extensively in Michigan and is also known as a Michigan Left. It has been implemented successfully in Florida, Maryland, and Louisiana. MUT intersections are often located along corridors, with or without medians, where paved bulb-outs or loons can be added to accommodate the U-turn. The MUT alternative works well as a corridor treatment and also at isolated intersections. Partial MUTs are also used where direct left turns are permitted from the minor street.

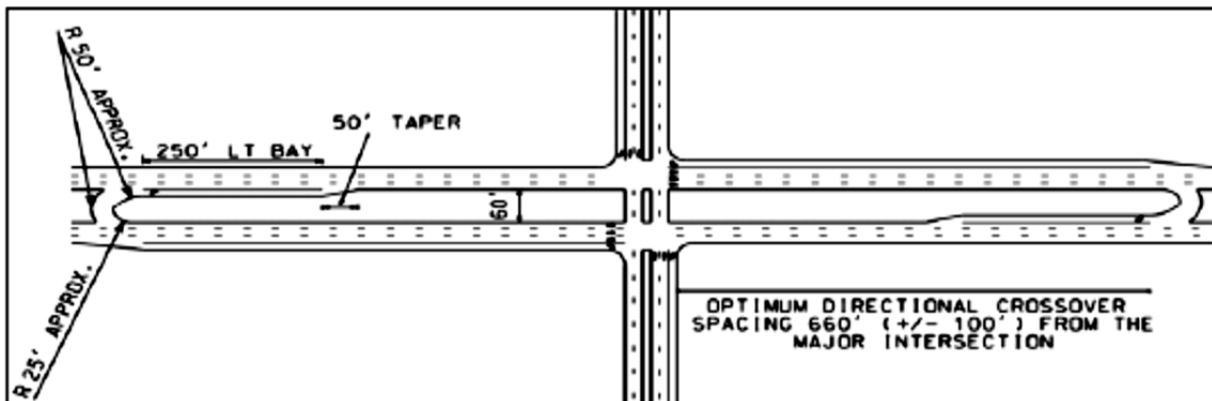

Figure 20: Typical MUT Intersection Design

2.2.2 Right of Way

Jug handles, loons, bulb-outs, or wide medians are utilized to allow large vehicles to utilize the U-turns. U-turn loons eliminate the need for wide medians. This also minimizes the need for right of way costs. Wide turning lanes and paved shoulders are used frequently. Refuges and medians should be wide enough to accommodate pedestrians, wheelchairs, strollers, or bikes. Curb ramps and detectable warning surfaces should be provided. The directional crossover is about 400 ft to 600 ft downstream from the main intersection according to the AASHTO Green Book. The desirable separation distance between U-turn crossovers is 150 ft, and the minimum is 100 ft. According to the design vehicle, median widths range from 8 feet for passenger cars to 69 feet for WB-67 trucks. Recently some MUTs have been built without medians to reduce right of way. Bulb-outs and loons were used instead. The crossovers in this alternative are directional and not two way so channelization can be implemented to avoid wrong way movements. Small turning radii of 50 ft or less slow down vehicle movements and reduce the saturation flow rate. A large radius of 70 ft or greater should be used for higher turning speeds and to increase the saturation flow rate. The large radii will require more right of way and wider medians. If the MUT is replacing major and minor street left turns then dual lanes should be implemented at the U-turn crossover. The dual U-turn crossover should be 30 feet wide. The typical lane width is 12 ft, and an

additional 10 ft are needed for drainage and utilities. According to the AASHTO Green Book, the right of way for MUTs varies from 139 ft for four lane streets and 165 ft for eight lane streets. Minor streets with two through lanes can have a shared through/right turn lane to avoid additional right of way. This method is not recommended on major streets because of the high speeds. If the right of way is available, it is recommended to have a continuous right turn lane on the major street from the U-turn crossover. This will allow vehicles using the crossover to move quickly to the right lane and provide enough lane storage. Depending on the available right of way, one of the design variations will be implemented:

- Directional crossovers placed on the minor street to reduce the major street right of way and median width
- Placing a stop-controlled directional crossover right before the primary intersection
- Having loons in place at crossover intersections to reduce median width requirements
- Placing crossovers on both the major and minor street

Access management is very important and can affect the right of way. Having a stop-controlled crossover before the main intersection could improve adjacent land use access by eliminating the need to cross the main intersection twice.

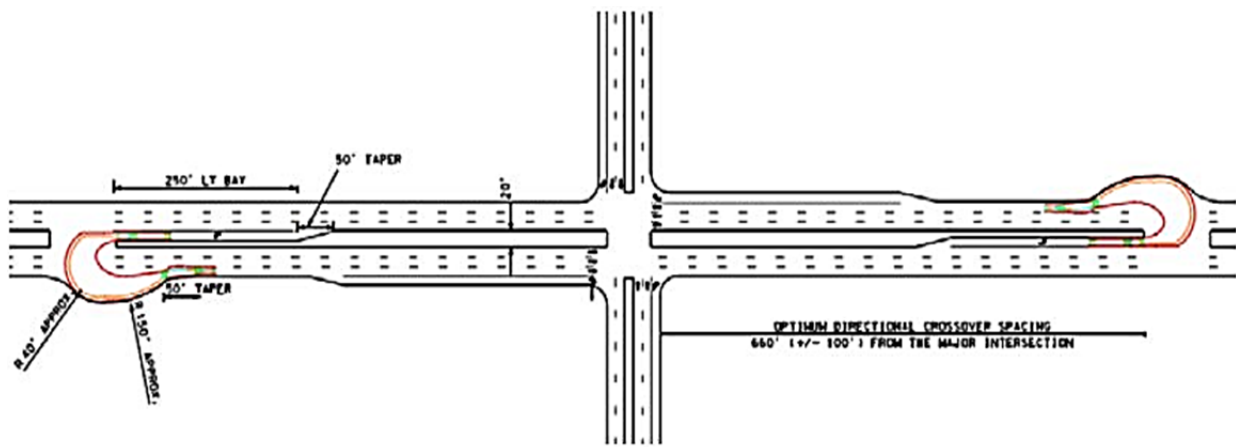

Figure 21: Loon Implementation at a MUT Intersection

2.2.3 Pedestrian and Bicyclist Interaction

Pedestrians crossing a MUT intersection and using the crosswalks have fewer threats due to the reduced number of conflicts. However, wide medians or refuge areas may increase the walking time and distance for pedestrians. Pedestrians cross the major street during the through and right turn signals of the minor street. There should be sufficient green time for pedestrians to cross in one stage due to the 2-phase signal operation, but if that's not the case they can cross in two-stages and use the refuge area. The MUT two-stage crossing provides increased crossing times than single stage crossings at conventional intersections. Pedestrian pushbuttons are required at the medians incase two-stage movements are necessary. The absence of left turn lanes also reduces the number of lanes needed to be crossed by pedestrians when compared to the conventional

intersection. The U-turn crossover can allow for the creation of a mid-block pedestrian cross walk. Special considerations should be given to pedestrians with special disabilities.

Accessibility to pedestrians with disabilities and vision and/or mobility impairments should be accounted for. The Americans with Disabilities Act (ADA) and the Public Rights-of-Way present policies and guidelines for the intersections to accommodate all pedestrians. Pedestrian walkways must be delineated through landscaping, curbing, or fencing in order to accommodate vision-impaired pedestrians. Convenient slopes should be provided for wheelchair users and strollers. Curb ramps and detectable warning surfaces at the edge of sidewalks should be provided. Locator tones and audible speech messages need to be provided at pedestrian signals to assist blind pedestrians. Push buttons also need to be accessible by wheelchairs. The crosswalk widths should be wide enough to allow pedestrians and wheelchairs to cross without delays. The MUT crossing is similar to conventional intersection crossing and they are quite easy and convenient to use.

Although bicycle accommodations are not commonly seen on MUTs, they are now becoming widely recognized and implemented. Bicycle lanes or turn queue boxes are built to accommodate these users. MUT through and right turning bicycle users have higher percentages of green time than conventional intersections. Right turn traffic lanes are commonly shifted to the right of bicycle lanes to prevent conflicts between the two users. Bicyclists can complete left turns using one of the following three alternatives:

1. Using the traffic lanes as passenger cars to make the turns.
2. Using bicycle ramps on sidewalks or shared paths on the cross walks.
3. Using bicycle turn queue boxes. When the bicyclists are approaching the intersection from the minor street they wait for the green light and proceed to the bicycle turn queue box. Once the major street gets the green light they can proceed along the major street. This is the most desirable approach.

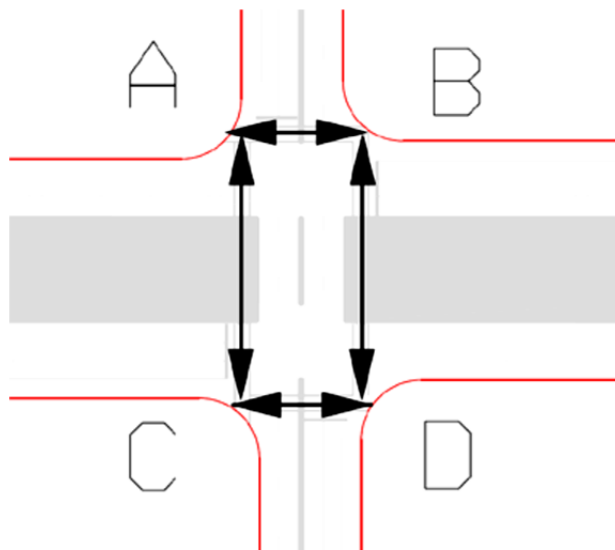

Figure 22: Pedestrian Movements at a MUT Intersection



2.2.4 Wayfinding

MUT intersections relocate conventional left turns which are different from what drivers expect. Therefore, Wayfinding is needed to prevent vehicles from making left turns at the intersections. Signs and pavement markings must be provided far enough in advanced of the intersection to direct the vehicles properly. Minor streets should provide signs for vehicles intending to make lefts onto the major street. These signs should direct the users to the right side and provide details on the U-turn crossover positioning. Use proper overhead and ground-mount signs to guide vehicle through the alternative and prohibit left turns on the intersection. Common signs from the MUTCD are "No Left Turns" and "One Way". "Fishhook" signs are used to direct the vehicles from the minor street onto the U-turn crossovers. Pavement marking and wrong way signs should also be utilized to prohibit left turns on the main intersection. A minimum of two guide signs are commonly used in this alternative; an advanced sign before the intersection and the other located at the main crossing intersection. Stop bars are placed across the lanes and must be placed no more than 30 ft or no less than 4 ft from the nearest edge of the pavement. The MUT requires adequate lighting at the intersection specifically at conflict points and crosswalks.

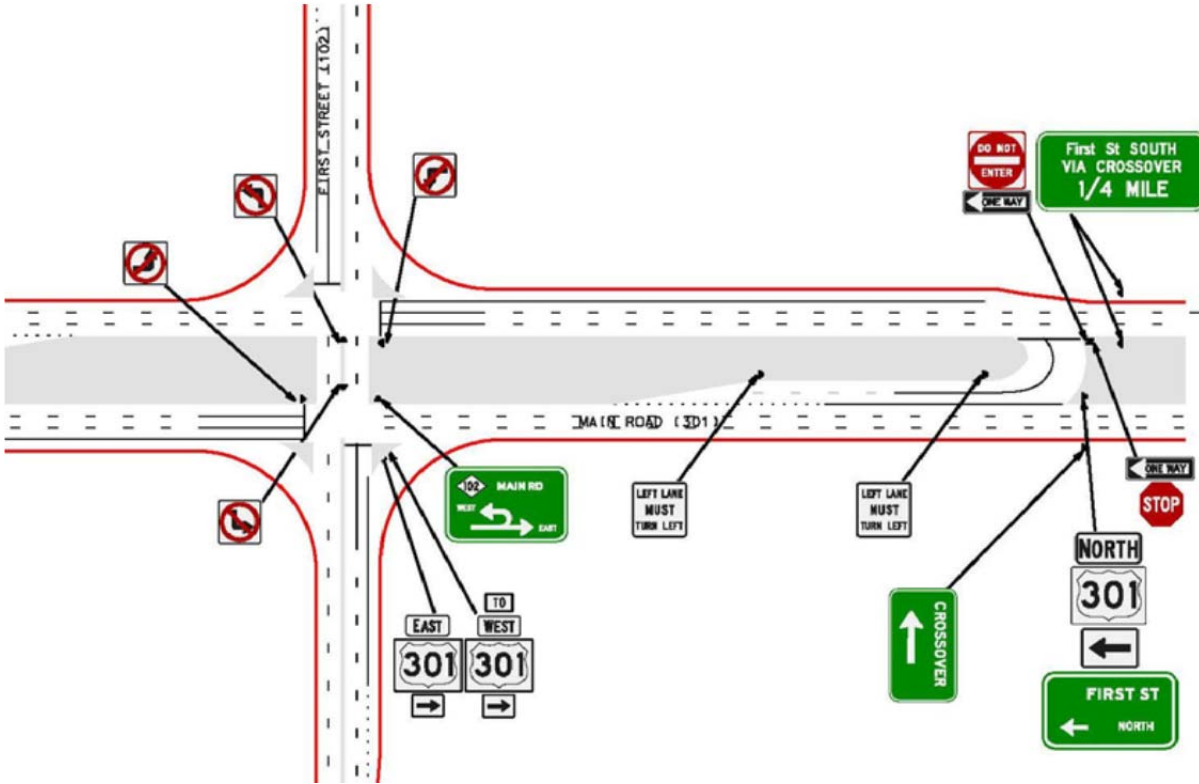

Figure 23: Typical Signing Plan for a MUT Intersection



2.2.5 Signalization

The U-turn crossovers may be signalized or unsignalized; in some cases, a stop-controlled crossover will be sufficient. Most mid-block U-turn crossovers operate as unsignalized intersections. However, cross-street minimum green times may need to be longer. The U-turn crossover green time should nearly match the intersection's minor street green time. Most MUTs have two additional signalized intersections, one at each intersection of the major street and another at the U-turn crossover; MUT intersections range from three to five signals. It is common for a single controller to control all the signals in the system, but multiple controllers can also be utilized. Signal heads must be placed no less than 40 ft and no more than 180 ft beyond the stop bar. Two phase signal are commonly utilized in this alternative. This results in shorter signal cycle length and more phases per hour for pedestrian and bicycles. These shorter cycle lengths allow for less time to be available for vehicles to store and form queues. There will be less "don't walk" time between "walk" times. It is recommended to prohibit the RTOR (Right Turn on Red) on the minor street to eliminate weaving conflicts on the major street. Intersections with high peak volumes may prohibit RTOR at these hours to avoid weaving and conflicts. Left turn movements have more green time per cycle. Cycle lengths range from 60 to 120 seconds. Pedestrian crossing signals last about 33 seconds. Figure 25 shows the signal phasing plan typically employed at an MUT intersection with signalized crossovers. Basically, the major street receives green indications during one phase and the minor street and crossovers receive green indications during a second phase.

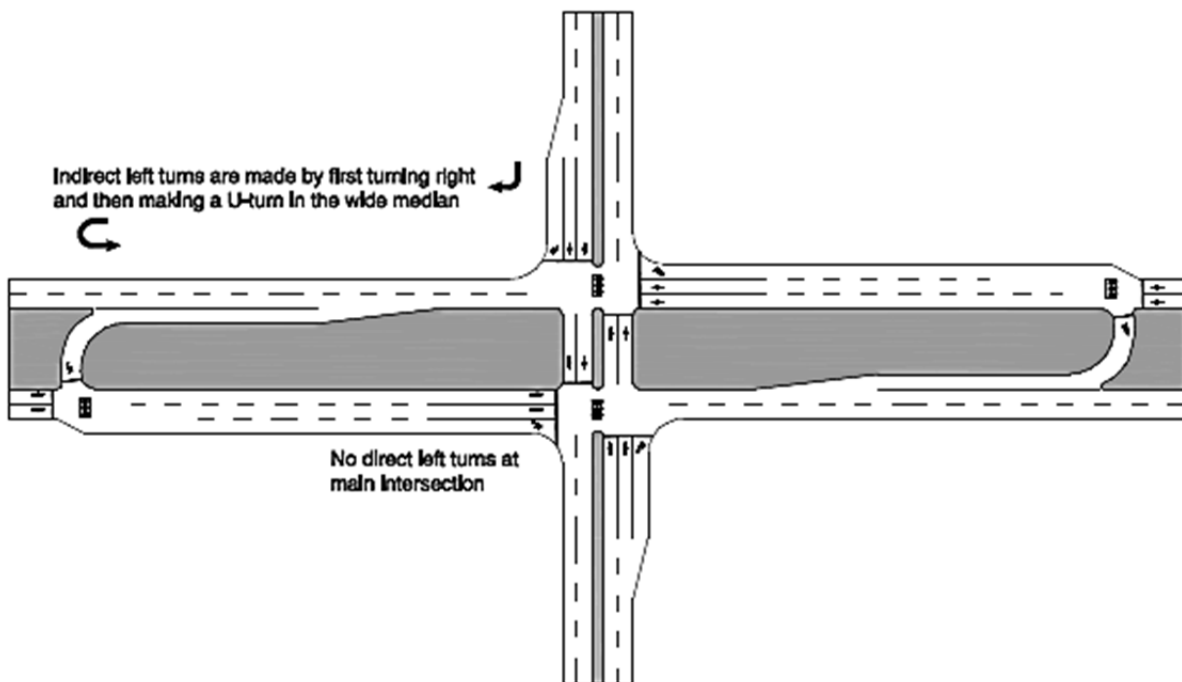

Figure 24: Typical MUT Intersection Signal Location

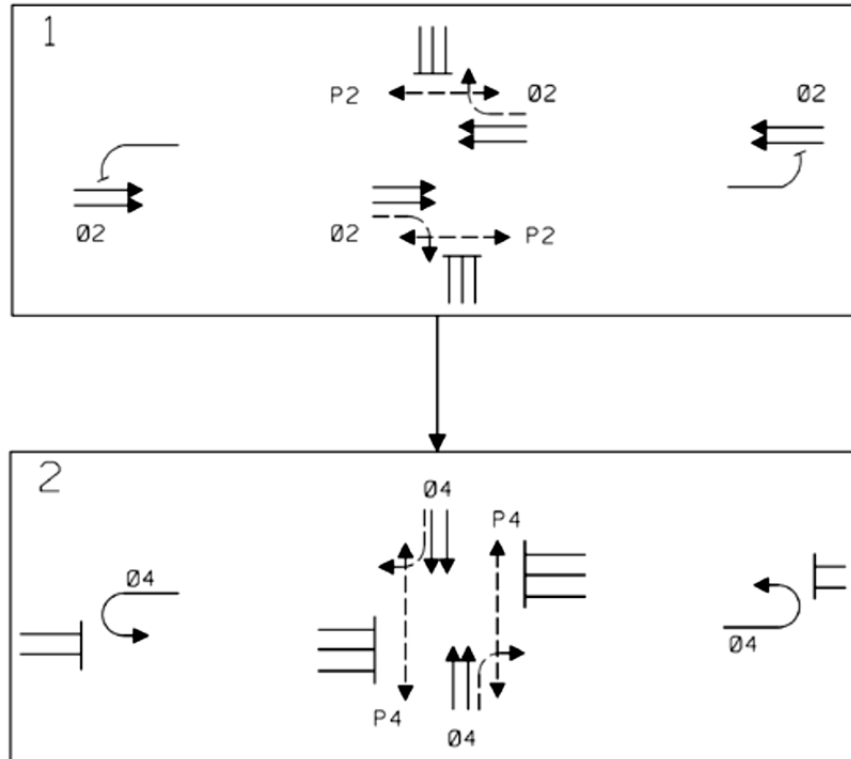

Figure 25: Typical Signal Operating Plan at MUT

2.2.6 Benefit-to-Cost Ratio

In general, medium benefit-to-cost ratio was experienced when compared to the conventional intersection, mostly due to the extra signalization needed. Right of way footprint also increases the cost of the construction of these alternatives. The right of way costs vary by geographical location. Using loons and no medians can save money in right of way costs. The additional control devices are also a reason for the higher cost. This alternative can be constructed easily when converted from a conventional intersection. Several MUTs have been built around the United States and their costs were analyzed below:

- 1- Location: Legacy Drive at Preston Parkway, Plano, TX
Year: 2010
Cost: \$1.7 million
- 2- Location: 12300 South and Minuteman, Draper, UT
Year: 2011
Cost: \$5.1 million

Grade separated arterials cost around 10 to 30 million dollars to construct. The cost for the first two MUT locations varied from 1.6 to 2.3 million dollars. Both these project's cost included construction crossover but required minimal modification to the main intersection. MUTs are a cheaper alternative that offer various benefits to pedestrians, bicyclists, and vehicles.



2.2.7 Performance Measures

Although travel times can be longer for left turning vehicles on MUT alternatives, it performs efficiently under high volumes. These intersection's left turns tend to have equal or improved delay and travel time when compared to conventional intersections. Travel time savings increase from 10 to 40 s/veh on MUT intersections. Average stops are reduced by about 20 to 40 percent, through arterial traffic delay is reduced, speed is increased, and progression is smoother. Crossing pedestrians and bicyclists have fewer threats. Safety is increased and conflict points are reduced. MUT works best at intersections with high through, left turn volumes, and where the cross street through volumes are insignificant. MUT intersections improve capacity by 14 to 18 percent. The total throughput increases by 15 to 40 percent while critical lane volumes are reduced by 17 percent. U-turn saturation flow rate is reduced by as much as 20 percent over the left turn saturation flow rate due to the slower movement of the U-turns. MUT corridors increase capacity by 20 to 50 percent and reduce travel time by 17 percent. The average speed in the MUT increases by 25 percent. It has shown that the MUT improves performance by a level of service grade on average compared to a conventional intersection.



2.3 Restricted Crossing U-Turn

2.3.1 Area Type and Roadway Conditions

The RCUT is suitable for a wide variety of locations. It can be used as a safer form of stop or yield control on minor road intersections along multi-lane divided highways with high speed, predominantly in rural areas. They can also be implemented on urban and suburban highways that are highly congested to maintain the integrity of the major highway as a through route. The RCUT is also commonly used as a corridor treatment along signalized routes to minimize travel time while maximizing capacity and managing traffic speed. They are effective in a system of unevenly spaced intersections.

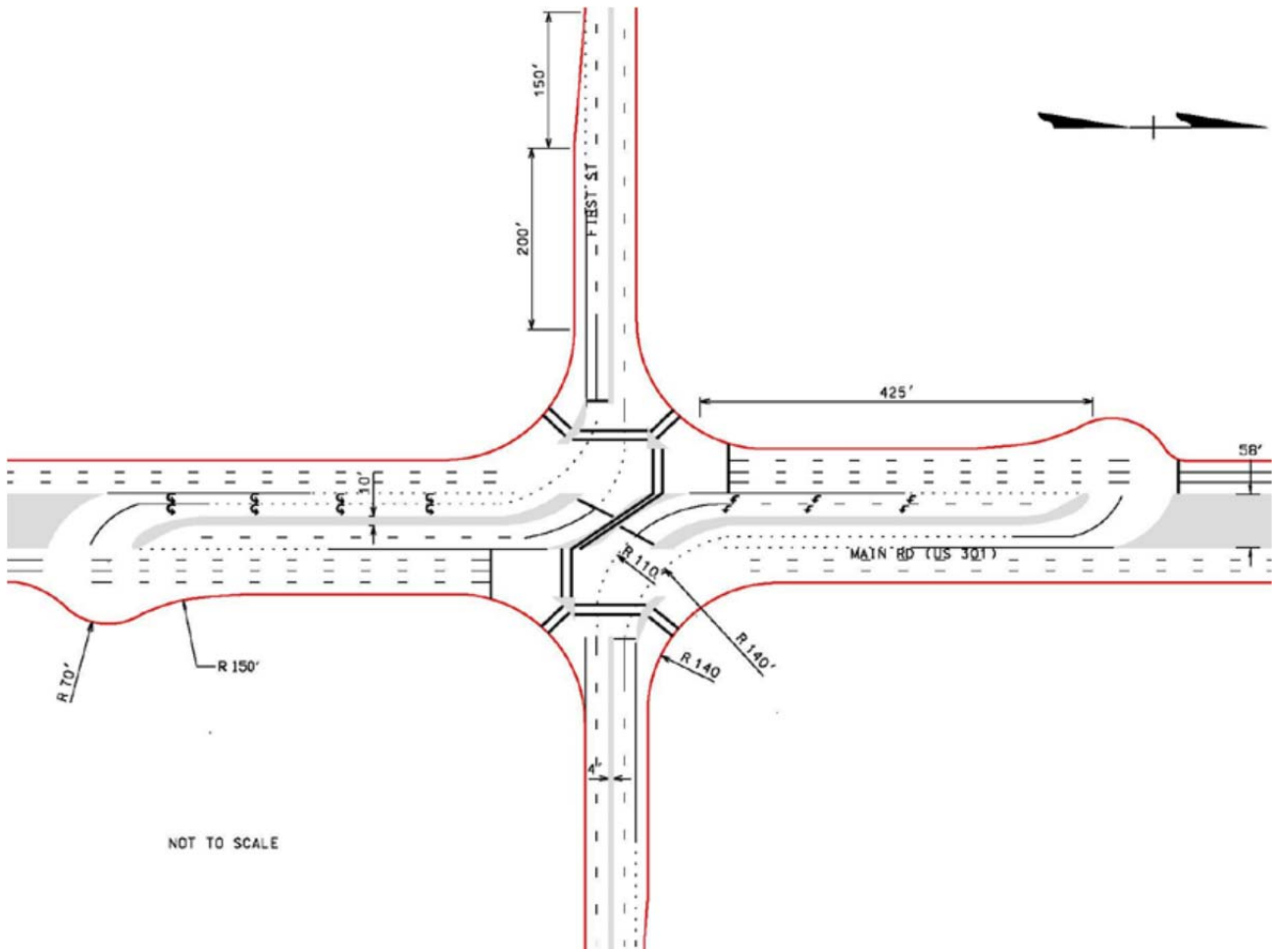

Figure 26: Typical RCUT Intersection



2.3.2 Right of Way

Wider medians and bulb-outs are utilized to accommodate larger trucks in the RCUT intersections. Loons or bump outs can be placed to recompense for narrow medians. The one way median crossover should be 400 ft to 800 ft beyond the intersection for stop and signal controlled intersections. RCUT intersections can have three or four legs; in four legged intersections there are two U-turn crossovers and left/through minor street restrictions. Unsignalized RCUTs may have channelized islands to allow farm equipment to make Minor Street through movements with ease. In order to prevent weaving in merge controlled intersections, the U-turn crossovers should be up to half a mile apart from the main intersection. Curbed islands, delineation, and traffic control devices can help prohibit vehicles from the minor street to make left turns on the main intersection. Consecutive RCUT U-turn crossovers need to have a minimum separation of 100 ft. The recommended and desired separation is 150 ft. In order to accommodate trucks, crossovers should have multiple lanes to accommodate the required turning path. The typical crossover width for one lane is 30 ft. Stop sign and merge RCUT crossovers usually have one lane only, but crossovers can hold up to two lanes. Major streets in the RCUT intersection can have four to eight lanes, while minor streets can have up to four through lanes. The right of way for the major street should be at least 70 ft. This would include a 10 ft median, four 10 ft travel lanes, a 10 ft left turn crossover, and a 10 ft buffer. The recommended right of way for major streets ranges from 137 ft for four lane roads and 161 ft for eight lane roads. Lanes are typically 12 ft wide. Minor street medians on this alternative should be at least 6 ft wide. Minor streets may have the option of having a channelizing island that separates all right turn lanes from the minor street lanes leaving the intersection, a channelizing island that separates minor street right turns remaining on the major street and minor street right turns using the U-turn, or having no channelization. The RCUT is the only existing at-grade design that permits each direction on a two-way arterial to function independently.

Access management for RCUTs greatly applies to signalized intersections. RCUTs frontage roads are not required to serve nearby parcels, but this alternative allows adjacent driveways and side streets to be easily available. Driveways can be located at the end of the U-turn crossover. RCUT designs are flexible and have multiple options for the locations of crossovers, which allows access points to be accommodated easier. RCUTs also have the ability to control speeds using the signals; they can lower speeds to accommodate access points and pedestrians. RCUT corridors can facilitate more signals and provide signalized driveways and crossovers. RCUTs access managements will not be a major cost and will not require a lot of right of way since there is no dire need to concentrate side street and driveway movements.

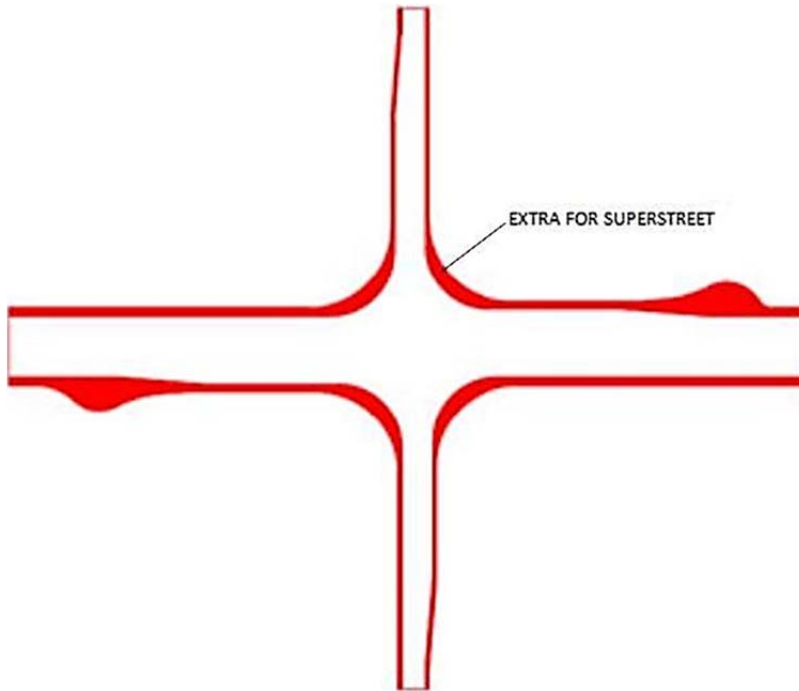

Figure 27: Typical Footprint for an RCUT Intersection

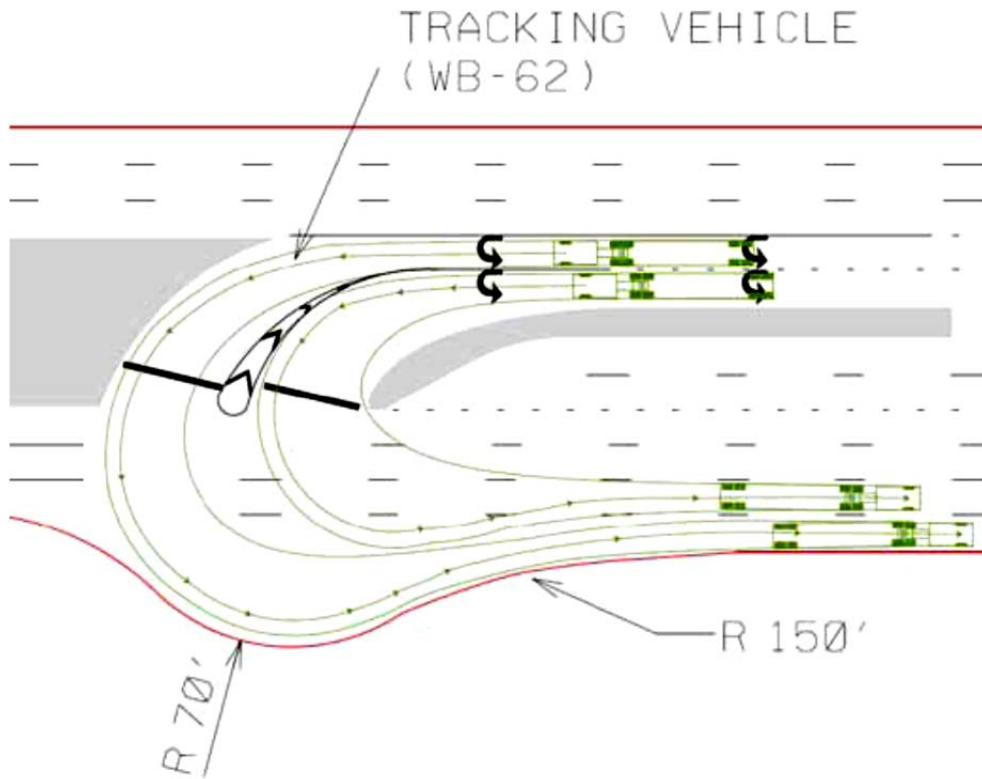

Figure 28: Typical Loon at an RCUT Crossover



2.3.3 Pedestrian and Bicyclist Interaction

On the major road the pedestrian crossings are set up as a diagonal path that goes from one corner to the opposite corner. This crossing method is called the “Z” crossing which is shaped like the letter and is completed in six movements. Another crossing alternative is done by having the minor street be offset in order to allow for a perpendicular pedestrian crossing on the major street to be available. This crossing decreases pedestrian exposure to vehicles, but cannot be built on existing streets. This crossing alternative is recommended at locations where the minor streets or driveways have not been built. The “Z” crossing is the recommended crossing approach. Pedestrian crosswalks on the RCUT may be longer for pedestrians to cross when compared to the conventional intersection. By adding a raised barrier or channelization between the major street through lanes and the right turn lanes, the crossing distance could be reduced. Channelization like curbs, railings, and landscaping can direct and assist pedestrians when crossing the streets. RCUT’s short cycle lengths can help accommodate pedestrians, but less signalized movements and wide footprints may make it difficult to accommodate pedestrians in many situations. This alternative also allows the possibility of having mid-block crosswalks at the U-turn crossovers. Three legged RCUT intersections require at least one mid-block crosswalk; two mid-blocks can reduce the amount of out-of-direction travel for pedestrians. They also accommodate pedestrians and bicycles through channelization that serve as an effective refuge island. Prohibiting right turns on red (RTOR) will diminish conflicts for pedestrians. Pedestrian crossings can be done in one or two-stages, pedestrians can use the median if crossing in two-stages. Two-stage crossings are mostly used in RCUT alternatives. The time allocated for pedestrian “walk” time is the same as the minor street green time. Although crossing distances and conflicts may slightly increase, most RCUT pedestrian-vehicle conflicts are protected.

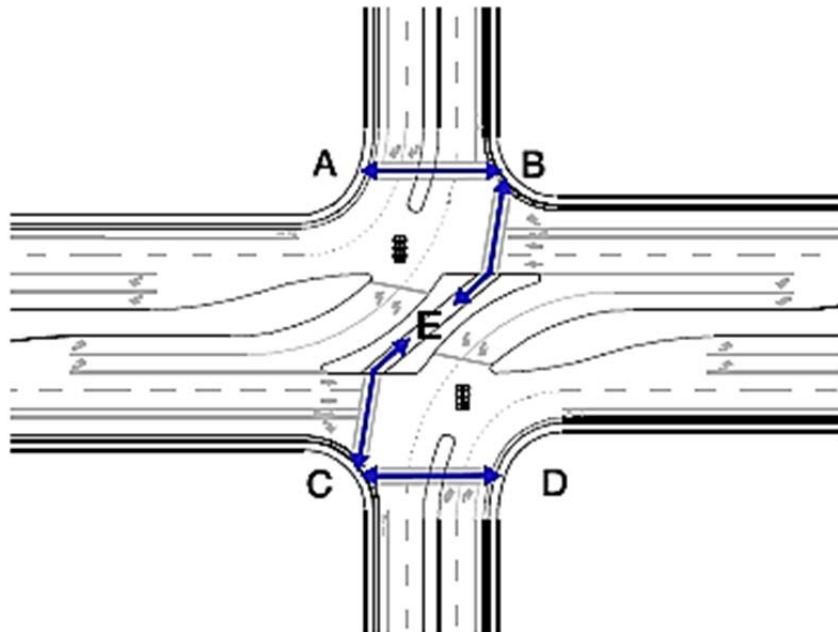

Figure 29: Pedestrian “Z” Movement at an RCUT Intersection

Accessibility to pedestrians with disabilities and vision and/or mobility impairments should be accounted for in the RCUT. The Americans with Disabilities Act (ADA) and the Public



Rights-of-Way present policies and guidelines which need to be accounted for to have an intersection that will accommodate all pedestrians. Pedestrian walkways must be delineated through landscaping, curbing, or fencing in order to accommodate blind pedestrians. Slopes should be provided for wheelchair users and strollers. Curb ramps and detectable warning surfaces at the edge of sidewalks should be provided. Locator tones and audible speech messages need to be provided at pedestrian signals to assist vision-impaired pedestrians. Push buttons need to be accessible by wheelchairs. The crosswalk widths should be wide enough to allow pedestrians and wheelchairs to cross without delays. Unsignalized RCUT intersections do not experience much pedestrian interaction, treatments like the pedestrian hybrid beacons (PHB) and the rectangular rapid flash beacons can be used.

Bicycles travel the major road the same way on the RCUT as the conventional intersection. The through and right turning bicycles at RCUTs are provided with more green time percentages, which usually results in lower delays and fewer stops. Bicycle lanes are usually separated from the general vehicle lanes by implementing buffered bike lanes or cycle tracks. The left-turning bicyclist can ride in the left-turn lane or stop at the crosswalk to use the “Z” crossing. Right-turn lanes can be shifted to the right of bicycle lanes to reduce conflicts and vehicle-bicycle exposure. There are three ways to serve the through and left-turn bicyclist on the minor streets. They may use the “Z” crossing like pedestrians do, they may use the U-turn crossover like vehicles, or they may pass through/across a channelizing islands. The direct bicycle crossing would only be utilized at a rural area were the “Z” crossing is not available. Specific signs will need to direct bicyclist to the pathway through movement on the median for direct bicycle crossings. The “Z” crossing is the best approach for bicyclist crossing the major street.



Figure 30: Bicyclist Passing Across a Channelized Island at an RCUT

2.3.4 Wayfinding

Wayfinding is not as vital in this alternative when compared to the other alternative intersections. Special pedestrian signs will be needed in the minor street offset design to prevent pedestrians from crossing at the minor street intersections and guide them to the crossing locations. Fewer signs will be required since crossovers are directional and channelization will prevent vehicles



from performing prohibited turns. Although this is the case, signs and markings will still be required to direct the vehicles through the U-turn crossover and prevent wrong way movements. Signs prohibiting parking on loons will be required to prohibit any obstructions. Signs and pavement markings prohibiting through and left turns on the minor street should be utilized. “One way” and “wrong way” signs should be used to assist the U-turn channelization. Suitable lighting should be provided on the RCUT’s conflict points and crosswalks. If right turns on red (RTOR) are restricted, signs will need to be provided to advise the vehicles on the minor street. Overhead lane signs can help guide the vehicles into the proper lanes, these signs should be about 350 ft prior to the stop bars. Extension pavement markings (Dotted) can help guide the turning vehicles. Stop or yield signs will be needed for stop-controlled and merge controlled crossovers. Merge controlled crossovers may also use flashing yellow beacons. Common pavement markings include right turn arrows, left turn arrows, left and through turn arrows, stop bars, and “Only” markings.

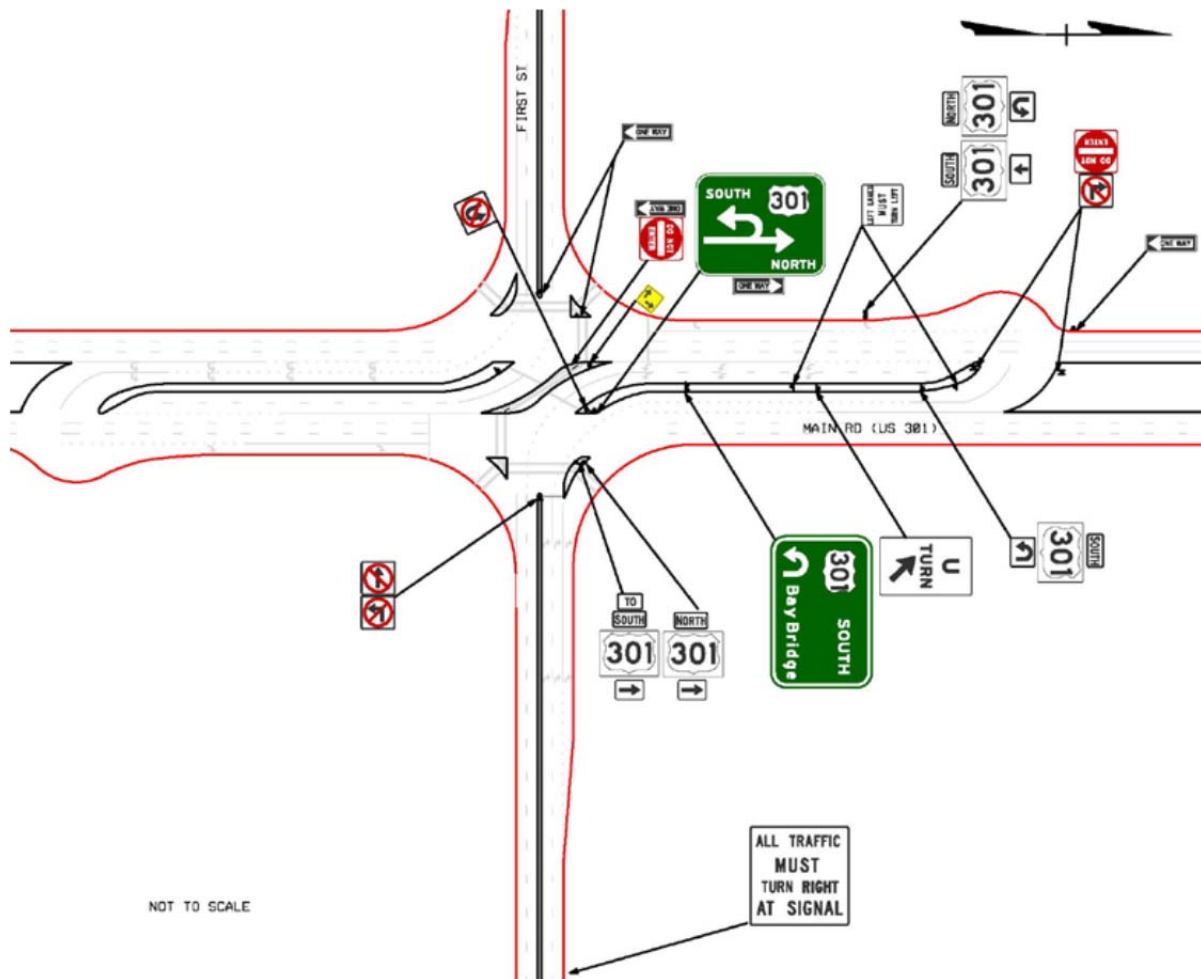

Figure 31: Typical Signing for RCUT Intersection



2.3.5 Signalization

RCUTs can be signalized, stop-controlled, or merge controlled. The signalized intersections can be commonly seen in urban and suburban corridors. Stop-controlled RCUTs can be seen at rural areas on four lane divided arterials. Merge controlled RCUTs are used at rural areas for high speed divided four lane corridors, they function as freeways. Signalized RCUTs serve various modal users and unsignalized RCUTs serve a variety of users including farm equipment at rural areas. Signalized crossovers with aligned side streets may have a third phase to avoid conflicts. This alternative minimizes the phases and only two phases are needed to accommodate the vehicles and pedestrians. One phase is for the main street and the other is for the crossover or Minor Street. One to six traffic signals will be needed to control a four legged RCUT intersection. The RCUT offers traffic signal placement flexibility. The arterials' through movement receive two-thirds ($2/3$) to three-fourths ($3/4$) of the green time allocated for the cycle. Cycle lengths are shorter at RCUTs than at conventional intersections which can reduce the amount of lost time per cycle. Typical cycle lengths range from 40 to 60 seconds for the main line and 25 to 40 seconds for the U-turns. The major street should have a high percentage of green time. Locations that have side streets aligned with crossovers can have the same signal phase if there is low volume and sufficient space available. RCUTs may be provided with bi-directional progression and signal timings at this alternative can use common cycle lengths or different cycles for the major street directions. Using a common cycle may cause delay in one of the directions, sometimes it is recommended to phase the directions individually. The intersection may be controlled by one controller or various controllers.

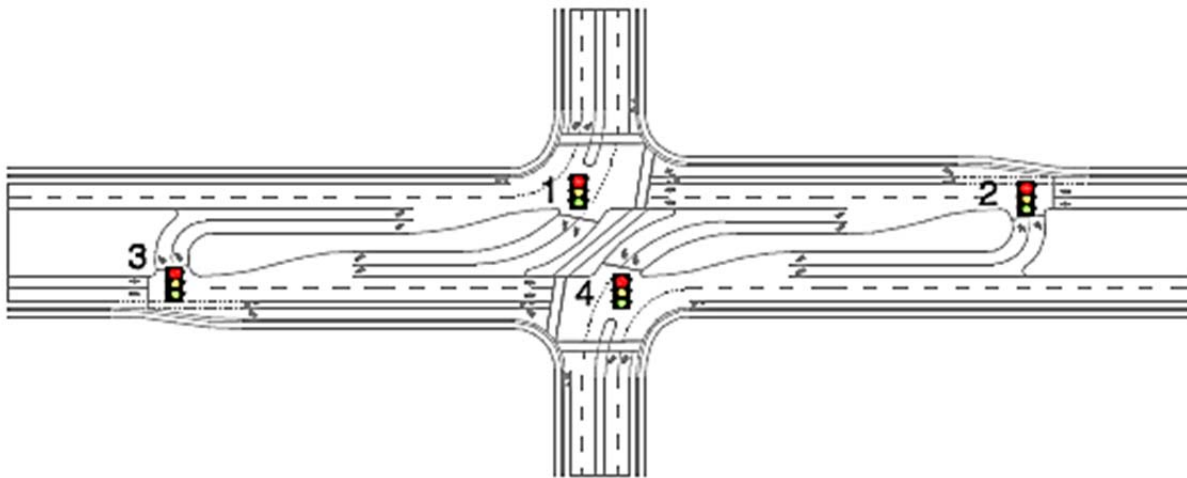

Figure 32: Signal Location at RCUT Intersection

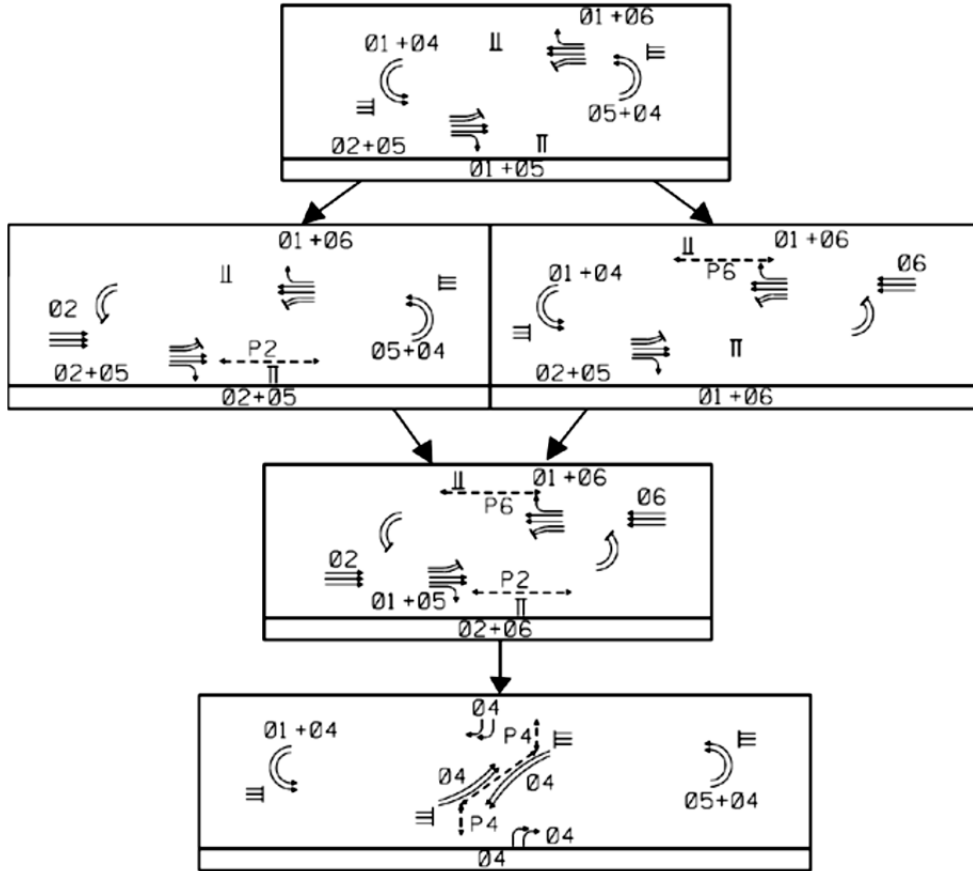

Figure 33: Typical Signal Operating Plan for RCUT

2.3.6 Benefit-to-Cost Ratio

RCUT alternatives provide a high benefit-to-cost ratio when compared with grade-separated interchanges. However, RCUTs are usually more expensive to construct when compared to conventional intersections. As the case for most alternative intersections this is due to the additional right of way needed and the extra signals/signs. With time and more public outreach the RCUT will likely reduce in cost. RCUTS can be constructed quicker and are commonly implemented as retrofits. Several RCUTs have been built around the United States and their costs are shown below:

- 1- Location: US 15/501, Chapel Hill, NC
Year: 2006
Cost: \$5 million
- 2- Location: US 17, Wilmington, NC
Year: 2006
Cost: \$2 million
- 3- Location: US 301 and MD 313, Kent County, MD
Year: 2005
Cost: \$618,000



RCUT costs are about 18 to 34 percent more than conventional intersection. The footprint for a RCUT is greater than that of a conventional intersection. The cost for conventional intersections compared to the RCUT ranged between \$1.5 million to \$1.8 million. In some cases the RCUT could cost less to build than conventional intersections, but much of this has to do with location. Although it may cost more to build RCUTs when compared to conventional intersections, their progression and traffic improvements may outweigh the extra cost.

2.3.7 Performance Measures

The RCUT alternative showed a 50 percent conflict points reduction when compared to conventional intersections. There is an approximate 1 minute longer travel time through the RCUT alternative. Crash analysis showed a decrease in crashes between 27 to 74 percent. Crash severity is also reduced by more than half with the use of the new alternative. These crashes include fatal and injury, left turn and angle. There is a nine percent reduction in crashes involving major injuries or fatalities. Sideswipe, rear end, and other type of crashes either decrease by a small value or slightly increase. The RCUT showed a 30 percent increase in throughput and a 25 to 40 percent reduction in travel time was reported. RCUT works best under high volume scenarios and at intersections with heavy highway left turn volumes and low minor road volumes. Shorter cycle lengths reduce delays for all users in the arterials. Peak travel times decreases on the RCUT intersection. Travel speed increases by about 15 percent using the RCUT alternative.



2.4 Diverging Diamond Interchange (DDI)

2.4.1 Area Type and Roadway Conditions

The DDI is a form of an interchange along freeways and works at most urban, suburban and rural areas with heavy volumes of left turns on to and off of freeway ramps. It is also known as Double Crossover Diamond (DCD) Interchange. This alternative can be implemented as an underpass or an overpass at moderate but unbalanced crossroad traffic volumes through the interchange. DDIs are usually retrofits of existing diamond interchanges which have left turn related safety concerns at the interchange intersections and there is a need for additional capacity without widening the roadway or the bridge.

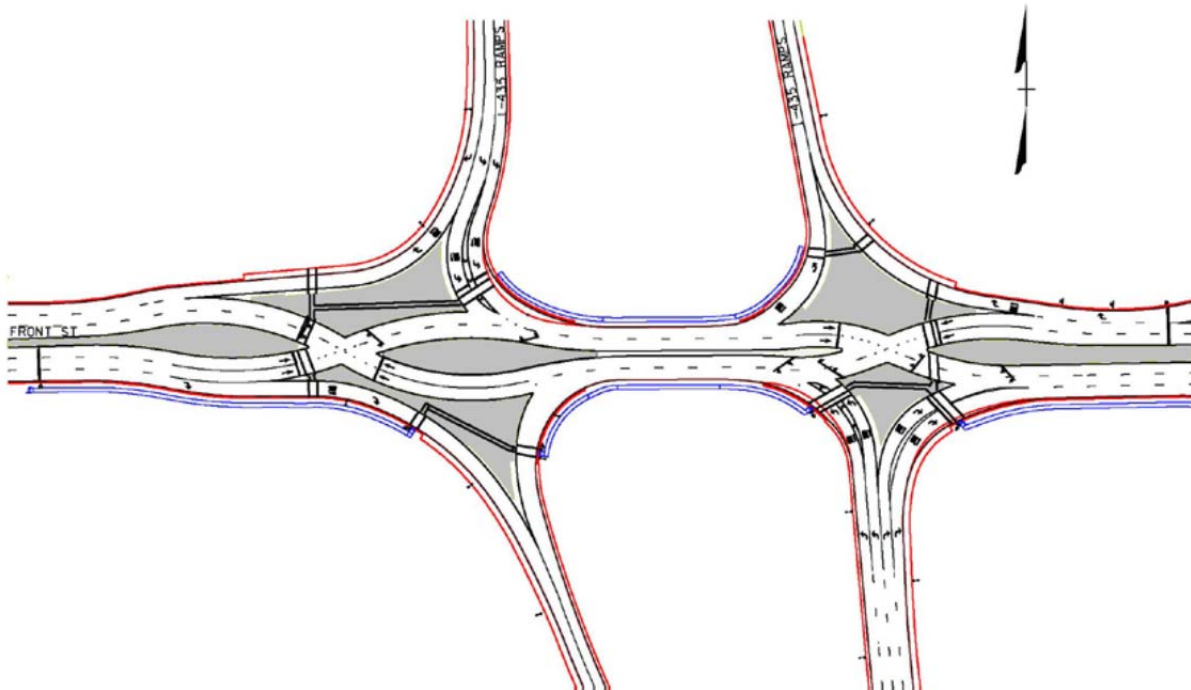

Figure 34: Typical Full DDI Plan View



2.4.2 Right of Way

The inbound and outbound movements during the crossover may be channelized to guide the drivers through the complex movement and onto the proper lanes. DDIs hardly require any extra right of way when being retrofitted from conventional diamond interchanges. The DDIs need to implement terminal directional crossovers for the freeway facility's entering and exiting movements. Bulb-outs or reverse curvatures will be applied right before the crossovers. They will require a wider right of way and large channelization islands that can be utilized for pedestrian refuges. Wider islands are recommended in order to refuge and accommodate all pedestrians. The islands length should be at least 6 ft. A median separates the two directions of the through traffic in the interchange and this median can be utilized as a shared-use pathway for pedestrians and bicyclists. The DDI's extra right of way due to the removal of the left turn lanes can provide accommodations for pedestrian and bicycle lanes adjacent to the travel lanes. Acceleration lanes may be provided at the freeway to offer queue storage. Most overpass designs use a single bridge structure. Overpass designs have the ease of adding lanes to the existing roads by building a parallel structure. Interchanges with underpasses have less flexibility and the right of way is very limited since relocating substructure components will be nearly impossible. DDI's radii must accommodate the new left turns onto the ramps, this will entail extra pavement and possibly additional bridge structure. Additional right of way will be needed for the right turning vehicles coming off the ramps. Reducing the distance between the crossovers can improve traffic flow and reduce the right of way needed. The distance between crossovers depends on the right of way available, so the DDI provides flexibility when it comes to choosing this distance. The common distance between the crossovers range from 410 to 470 ft. Appropriate lane widths range from 12 to 15 ft. In some cases crossover intersections will need to be further apart requiring additional right of way. DOT recommends crossovers to be 45 degrees or larger to avoid any wrong way movements. Auxiliary lanes may be used on these alternatives to assist weaving traffic. The three forms of auxiliary lanes are dedicated left, shared through and left, and exclusive through. Access management has caused a lot of concern through the DDI alternative. High throughput and near adjacent signals cause queues and spillbacks onto the interchange making access to parcels harder to accommodate.

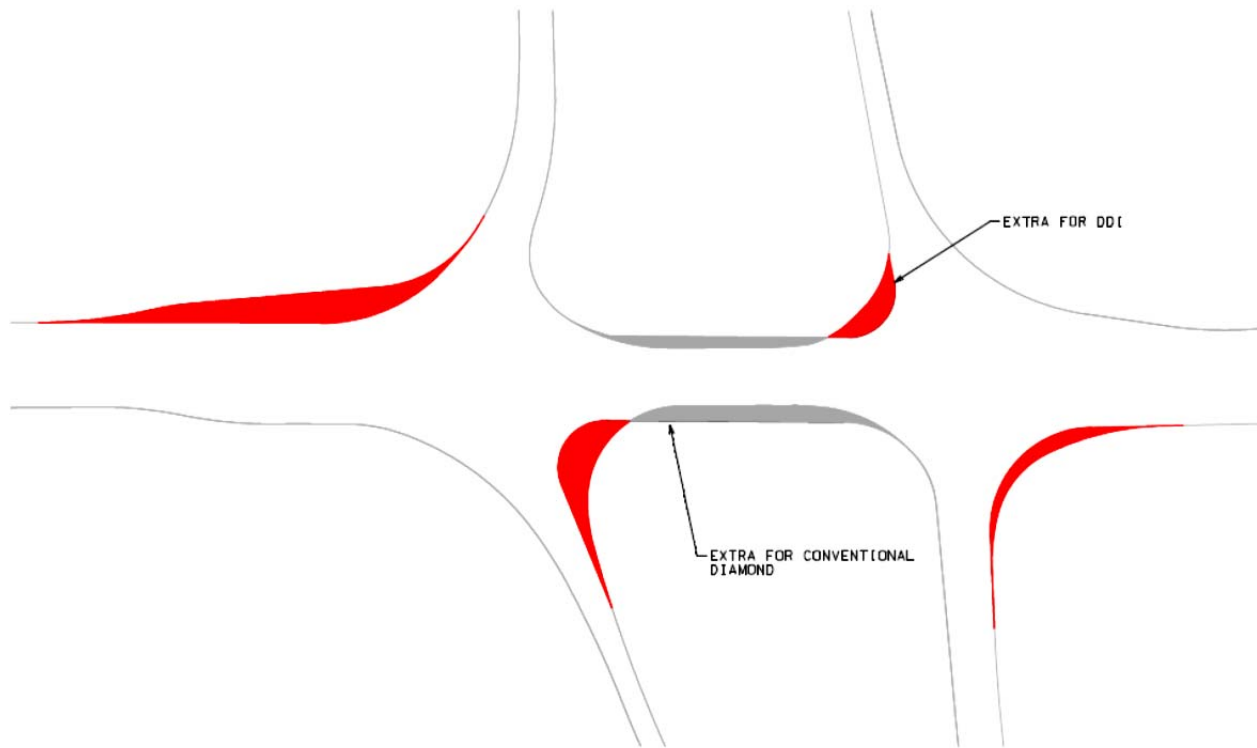

Figure 35: Typical Footprint for DDI

2.4.3 Pedestrian and Bicyclist Interaction

DDIs with overpasses offer the most flexibility to accommodate pedestrians and bicyclists. Crossing distances are condensed so pedestrians merely cross one direction of traffic at a time. The separation and channelization of the directions make it possible. The crossing distance for pedestrians is also minimized. Pedestrian crossings are signalized at the crossover, but may not be signalized on the turn lanes to and from the freeway. The absent need of left turn pockets frees up right of way for the DDI. This extra right of way can be used for sidewalks and bike lanes. The pedestrian signals and phases are shorter since pedestrians cross one direction at a time. Pre-timed DDI signals can assist in providing sufficient and extended pedestrian walk time. The pedestrian crosswalks will be located on the outside of the travel way and between the two through traffic signals in the median. The median crosswalks are recommended at overpasses to diminish pedestrian and left turning conflicts from the freeway traffic. Interchanges with overpasses provide pedestrian crossing phases with concurrent vehicle phases. Right turns do not provide restricted pedestrian signals so vehicles need to look out and yield to the crossing pedestrians. The median center crosswalks need to be signalized and protected by barrier walls to provide safety for the crossing pedestrians. The outside sidewalks are recommended for underpasses in order to evade conflicts with bridge columns that are between the two traffic directions. The outside pedestrian sidewalks may have to wait to the next adjacent signal to cross the road, which may extend the travel time for pedestrians. This is due to the lack of marked



crosswalks and may lead to jaywalking. Pedestrians can cross four vehicle turn lanes in each direction (Eight total) on underpasses. These crosswalks don't have to be signalized, but they are recommended to be in order to assure safety. The large channelization islands between the crossovers will provide extra refuge for crossing pedestrians. Some pedestrian crossings are not signalized and may require raised crosswalks and visible marking to protect pedestrians. Pedestrian signals are required at turns with multiple lanes. Signal poles need to be easily visible and aligned so pedestrians can be directed in the proper direction. Cut-through walkways on the cut-through islands can help guide the pedestrians through the crossing path; they should be at least eight feet wide to accommodate all pedestrians. Landscaping can be utilized to define the walkway boundaries instead of cut-through walkways.

Accessibility to pedestrians with disabilities and vision and/or mobility impairments should be accounted for. The Americans with Disabilities Act (ADA) and the Public Rights-of-Way present policies and guidelines which need to be accounted for to have an intersection that can accommodate all pedestrians. Pedestrian walkways must be delineated through landscaping, curbing, or fencing in order to accommodate vision-impaired pedestrians. Slopes should be provided for wheelchair users and strollers. Curb ramps and detectable warning surfaces at the edge of sidewalks should be provided. Locator tones and audible speech messages need to be provided at pedestrian signals to assist blind pedestrians. Signals will require locator tones to guide vision-impaired pedestrians to the push buttons. Push buttons need to be accessible by wheelchairs. The crosswalk widths should be wide enough to allow pedestrians and wheelchairs to cross without delays.

Bicycle users are accommodated in most DDIs. Some have constructed bicycle lanes through the crossovers. Others have been built with bicycle paths to be shared-use on the outside of the interchange. The reduced crossing distance results in extended crossing time for bicyclist and less vehicle exposure. There are three bicyclist accommodations in the DDI:

- 1- Marked bicycle lanes through DDI
- 2- Shared-use path or separate bicycle path
- 3- Shared vehicular lanes

Bicycle lanes should be provided at the right of the vehicular travel lanes. At interchanges with speeds exceeding 35 mph, protected bicycle lanes are suggested. Bicycle lanes should be wider than 5 ft. Bicycle lanes wider than 7 ft should provide buffers. Green colored pavement marking or lines can help delineate bicycle lane progression. Bicyclist should only stop at stop bars, in all other cases vehicles should yield. Shared-used paths for pedestrians and bicyclist are required to be a minimum 10 ft.

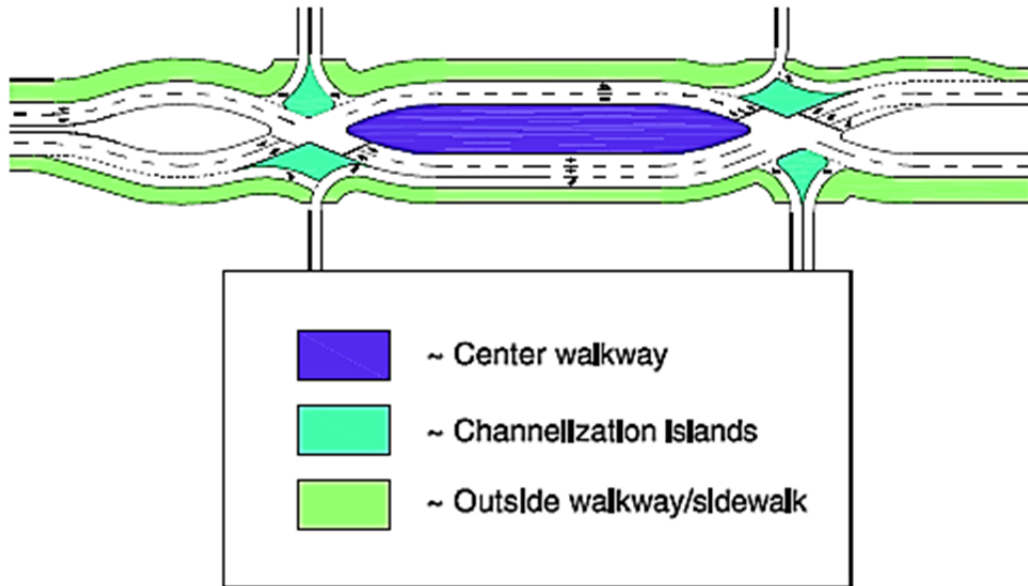

Figure 36: Pedestrian Movement at DDI

2.4.4 Wayfinding

Wayfinding is very important in the DDI alternative, they are used to regulate, warn, and guide vehicles through the new alternative. Regulatory signs instruct users on where and what they need to do to get where they want to go. Some of these signs include “Do Not Enter”, “Wrong Way”, “One Way”, “No Right Turn”, and many more. Warning signs advise the vehicles of any hazardous operations; these include lane split, reverse curve, yield ahead, and many others. Guide signs show routes and directions to destinations or paths. They can display distances and city street/city designations. There should be a sign located before the crossover, another past the first crossover, and the third sign guides the users to the ramps. Pavement markings define vehicle entry and exits for the ramps and the crossovers. They also delineate the multimodal paths for bicyclist and pedestrians. Some DDIs use white lines for left side lanes and yellow lines for right side lanes due to the crossover. Solid lines are used to discourage lane changing; they are useful on the cross-street at the crossovers. Lane use arrows on the pavement guide vehicles through the alternative. Stop bars are used at signalized intersections and yield lines are used at unsignalized exit/entry ramps. Crosswalk markings are also required to guide pedestrians through the paths. Lighting needs to be provided at pedestrian crosswalks, ramp exit/entry points, and conflict points.

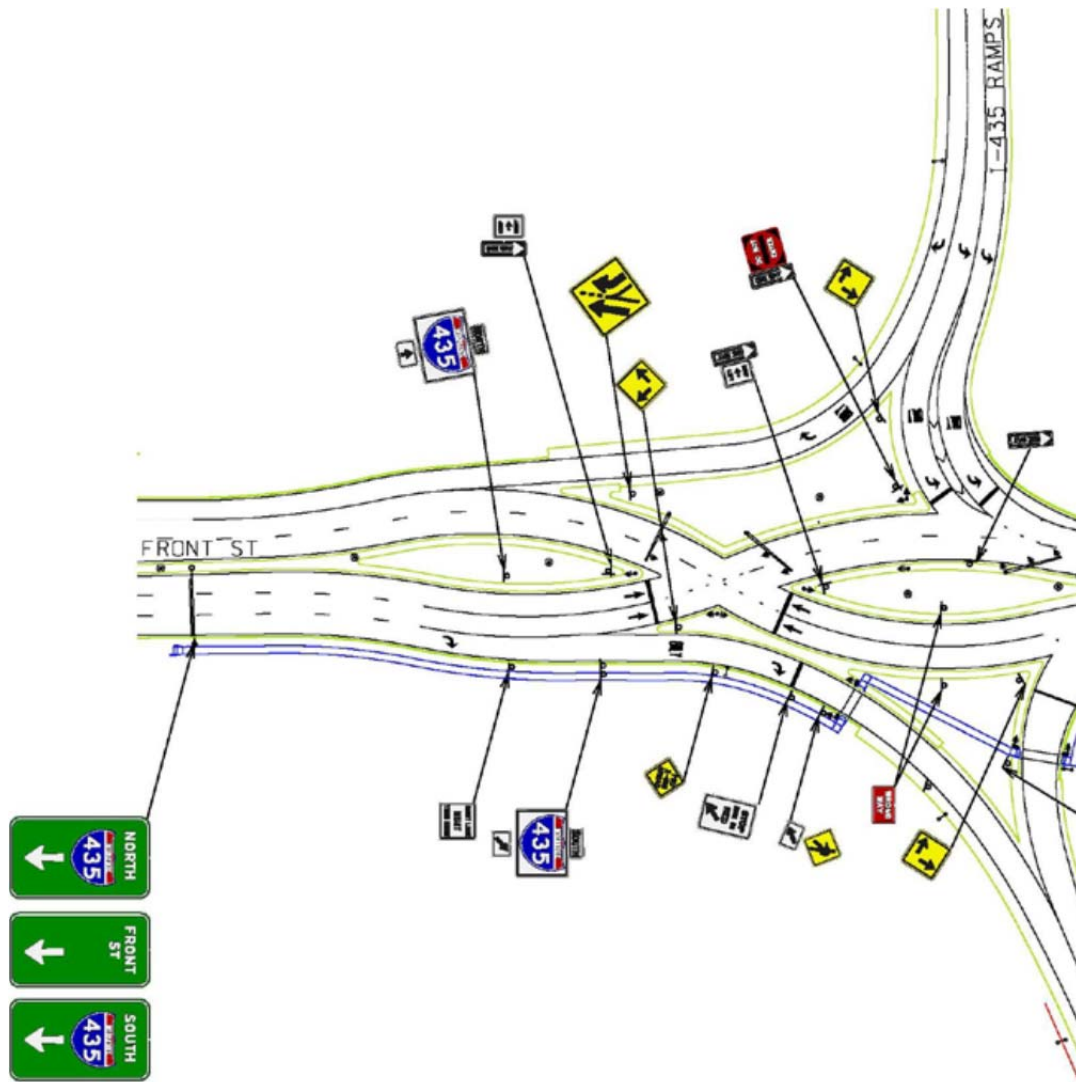

Figure 37: Signing and Marking Plan for DDI (Missouri)

2.4.5 Signalization

The DDI has a reduced number of signal phases and operates as a two phased system. This reduction progresses overall signal efficiency and improves cross street through traffic and left turns from the freeway. The left turn movements exiting the freeway are signalized or yield controlled. The yield control left turns with no acceleration lanes are applied at areas with low to modern traffic volumes. Signalized left turn movements are recommended when pedestrian facilities are in place. Right turn on red (RTOR) are not common at DDI ramps. The left turn movements onto the ramps are free flowing. On the other hand, right turns from the ramps should be yield controlled with no acceleration lane or free turn with acceleration lane. However, it is not recommended when there is high pedestrian activity. Meters may be applied at the entrance ramps to control the flow rate. Both crossover split signals operate independently and allows signalization flexibility. Pre-timed signal are recommended to assure efficient progression across the cycles. Typical cycle lengths range from 60 to 90 seconds. Actuated controls are



recommended for pedestrian only signals and at interchanges that combine heavy and very low movements. The signals in this alternative are controlled by one or two controllers. DDIs favor the cross street through traffic and revolve its phase design around these movements. This allows the through traffic to pass both crossover signals in one movement/phase. Supplemental signal heads may be used when the overhead signalization is hard to view.

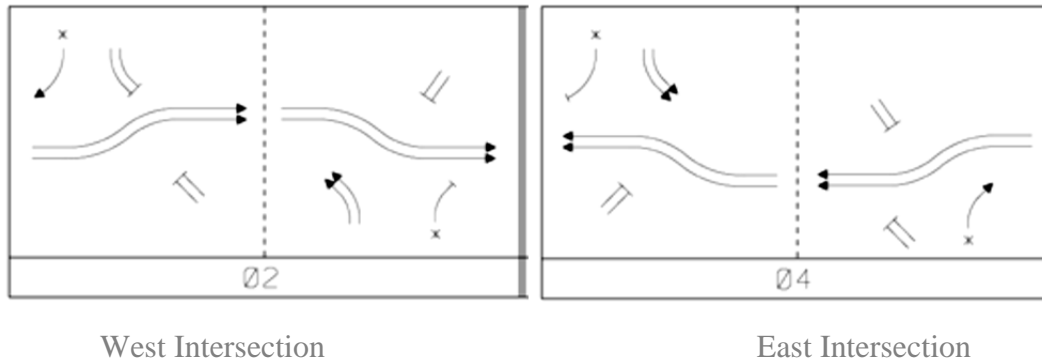

Figure 38: Typical Signal Operating Plan for DDI

2.4.6 Benefit-to-Cost Ratio

DDIs have a high benefit-to-cost ratio. DDI's construction costs are reduced when compared to typical interchange designs such as cloverleaf ramps. DDI's footprint typically fits the right of way and the bridge of the existing interchanges. This makes it less expensive and quicker to construct. The biggest factor in interchange cost is the structural cost; this is why DDIs are commonly implemented as retrofits. Several DDIs have been built around the United States and their costs are shown below:

- 1- Location: Bessemer St. and US 129, Alcoa, TN
Year: 2010
Cost: \$2.9 million (Retrofit)
- 2- Location: MO 13 and I-44, Springfield, MO
Year: 2009
Cost: \$3.2 million (Retrofit)
- 3- Location: Winston Rd. and I-590, Rochester, NY
Year: 2012
Cost: \$4.5 million (Retrofit)
- 4- Location: National Ave. and US-60 , Springfield, MO
Year: 2012
Cost: \$8.2 million (Retrofit)
- 5- Location: Timpanogos Hwy. and I-15, Lehi, UT
Year: 2011
Cost: \$8.5 million (Retrofit)
- 6- Location: Mid Rivers and I-70, St. Peters, MO



- Year: 2013
Cost: \$14 million
- 7- Location: CR 120 and Hwy. 15, St. Cloud, MN
Year: 2013
Cost: \$17.5 million
- 8- Location: Pioneer Crossing and I-15, American Fork, UT
Year: 2010
Cost: \$22 million

DDIs average construction cost for retrofits are between 3 to 8.5 million dollars. DDIs average construction cost for new interchanges are between 14 to 22 million dollars. DDIs have shown to be more cost effective because on average a cloverleaf interchange cost over \$20 million.

2.4.7 Performance Measures

DDIs provide additional throughput due to the two phase signals. The two phase signals also increase the capacity on the interchange. Queue spillbacks may occur at the departure zone, but spillbacks occur less frequently. Left turns are free flowing and do not interact with the opposing traffic. DDIs have about 12 less conflict points than the conventional diamond interchange. The DDI has shown reduction in total crashes, especially left turn crashes. Crossovers have displayed reductions in saturation flow rates. Total delays are reduced by about three times and stop delays are reduced by about four times when compared to the conventional diamond interchange. DDIs have half the amount of stops of the conventional diamond interchange. At high traffic volumes the DDI has lower delays, fewer stops, lower stop times, and shorter queue lengths. The service volumes in the DDI outperformed the conventional diamond interchange. Time lost due to numerous phases can be recovered through longer green time allocation to critical phases. DDI also greatly improve safety for pedestrians and bicyclists by completely removing direct left turns. Due to the reduced footprint, the DDI saves about seven million dollars when compared to the cloverleaf design. Capacity at the intersections increases by 15 percent and by 60 percent along corridors. These alternatives have also reduced the amount of crashes and their severity.

2.5 Roundabouts

2.5.1 Area Type and Roadway Conditions

Roundabouts are used at urban, suburban, and rural areas. Rural areas have higher speeds but lack to provide multimodal accommodations. Urban areas have low speeds and efficient multimodal facilities. Suburban areas use a mixture of the rural and urban design; they are similar to urban roundabouts but they are accessed at higher speeds. There are two categories of modern roundabouts; single lane or multilane roundabouts. Single lane roundabouts have entry design speeds of 20 to 25 mph with a maximum daily volume of 25,000 vehicles per day while the multilane roundabouts can handle up to 45,000 vehicles per day for two-lane roundabout and maximum entry design speed of 25 to 30 mph.

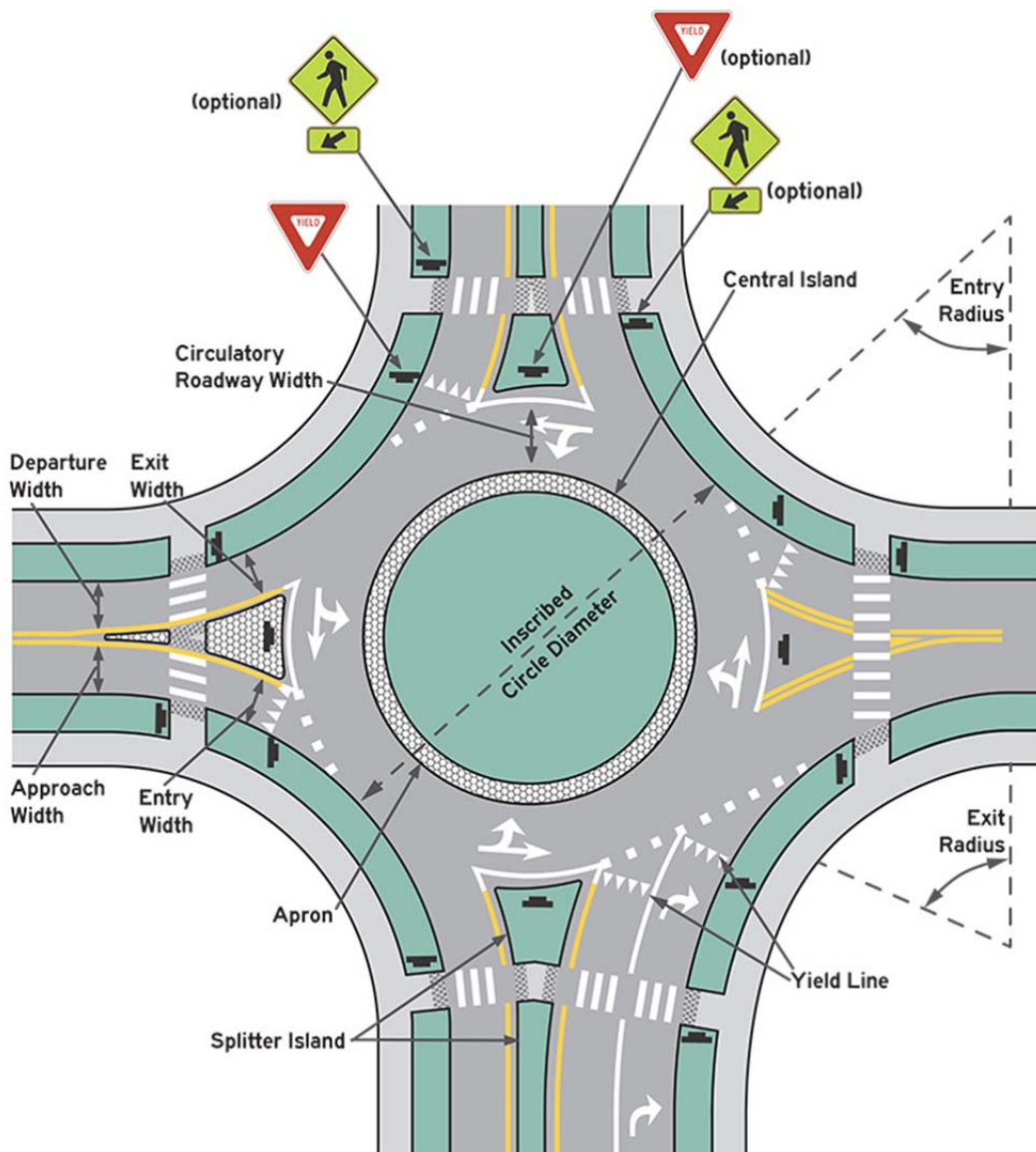

Figure 39: Typical Geometry of a Single Lane Roundabout

2.5.2 Right of Way

Roundabouts operate best at low speeds. In order to achieve low speeds horizontal curvature and narrow pavement widths are utilized. The right of way needed in roundabouts is curb ramps and landscaping, they designate the crosswalks for all pedestrians. Roundabouts are either single or dual lane alternatives. “Inscribed circle diameter is the distance across the circle inscribed by the outer curb of the roadway.” The minimum inscribed circle diameter (ICD) for a single lane roundabout is 100 feet. Smaller diameter can be used at locations that will not interact with heavy vehicles like the WB-15. The minimum inscribed circle diameter (ICD) for a dual lane roundabout is 150 ft. The deflection angle determines the entry speed. The speeds decrease with big deflection angles and bigger diameter. Entry widths for roundabouts with a single-lane entry are between 14 ft and 16 ft. In order to increase capacity and not require much right of way, flares can be implemented. In urban areas the minimum flare length is 80 ft and in rural areas the minimum flare length is 130 feet. Shorter lengths can be used if the right of way is inhibited. The circulatory roadway width should always be at least as wide as the maximum entry width. On roundabouts, central islands are always raised and usually landscaped. Some central islands have a traversable apron to assist trucks. These aprons are 3 ft to 13 ft wide. They have a cross slope of three to four percent away from the islands. On single lane roundabouts, entry radii at urban areas range from 33 ft to 98 ft and at local streets they are below 33 ft. On single lane roundabouts, exit radii at urban areas are no less than 50 ft and at locations with pedestrians they range from 33 ft to 39 ft. Right turn bypass lanes can be implemented if the roundabouts do not interact with pedestrians and bicyclists.

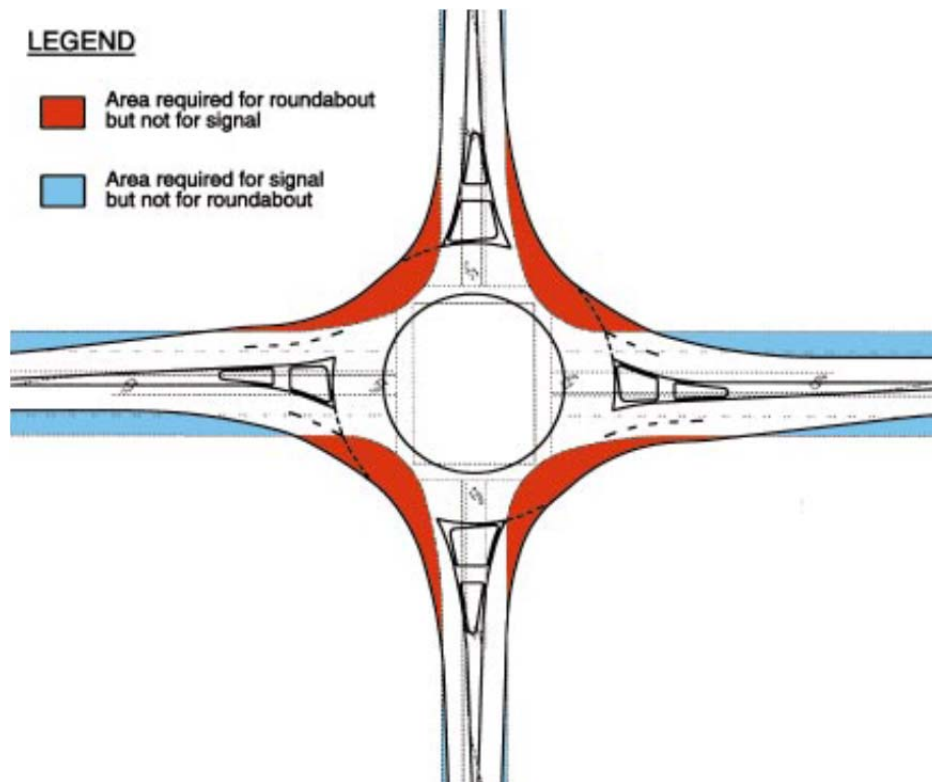

Figure 40: Typical Footprint of a Roundabout



2.5.3 Pedestrian and Bicyclist Interaction

Crosswalks are located at the perimeter of the roundabout right before the entry/exit legs are approached. The distance between the crosswalk and the leg is about a car length (25 ft) for single lane roundabouts and one to three car lengths for dual lane roundabouts. Pedestrians typically cross the street in two-stages, first to a median referred to as a splitter island, then to the second side of the road. Pedestrians will only cross one direction of traffic at a time. The minimum splitter island length is 50 ft. At grade refuges must be provided for pedestrians if raised splitters are implemented. The refuges have a minimum width of 6 ft to accommodate pedestrians and their strollers, wheelchairs, or bicycles. Pedestrian crosswalks are yield controlled and vehicles must give the right of way to the pedestrians. The crosswalk ramps need to be perpendicular to the curb/gutter line and they must have truncated dome surfaces to assist visually impaired pedestrians. Crosswalk locations depend on the direction of travel and they may be hard to locate at times. Sidewalks should be set back from the edge of the roadway for safety reasons. This set back distance is about 5 ft. Pedestrians cross the crosswalks when gaps are available; this is when no vehicles are approaching and the pedestrian has sufficient time to reach the median. Pedestrians may need about a 6 second gap to cross a dual lane roundabout. However this is not the case for visually impaired pedestrians, they are not able to use their sight to predict the best times to cross. Visually impaired pedestrians may need about a 9 second gap in both directions to begin crossing. This may be troublesome at peak hours. The best solution is to have vehicles stop for pedestrians with canes and assisting dogs using flashing beacons or pedestrian signals. According to PROWAG, two lane roundabouts require APS equipped signals to assist pedestrians with disabilities. Roundabouts may be troublesome for elderly and disabled pedestrians, but they must comply with the Americans with Disabilities Act (ADA).

Bicycle options slow roundabouts and make driving comparable to bicycles. Roundabout entering speeds might be around 15 mph to accommodate bicyclist. Bicyclist can use the traffic travel lanes in one lane roundabout or use the pedestrian crosswalks. Bicycle lanes are not used in roundabouts due to complexity and conflict points. On dual lane roundabouts, bicyclist must use shared pedestrian paths or paths that are separate from the roadway.

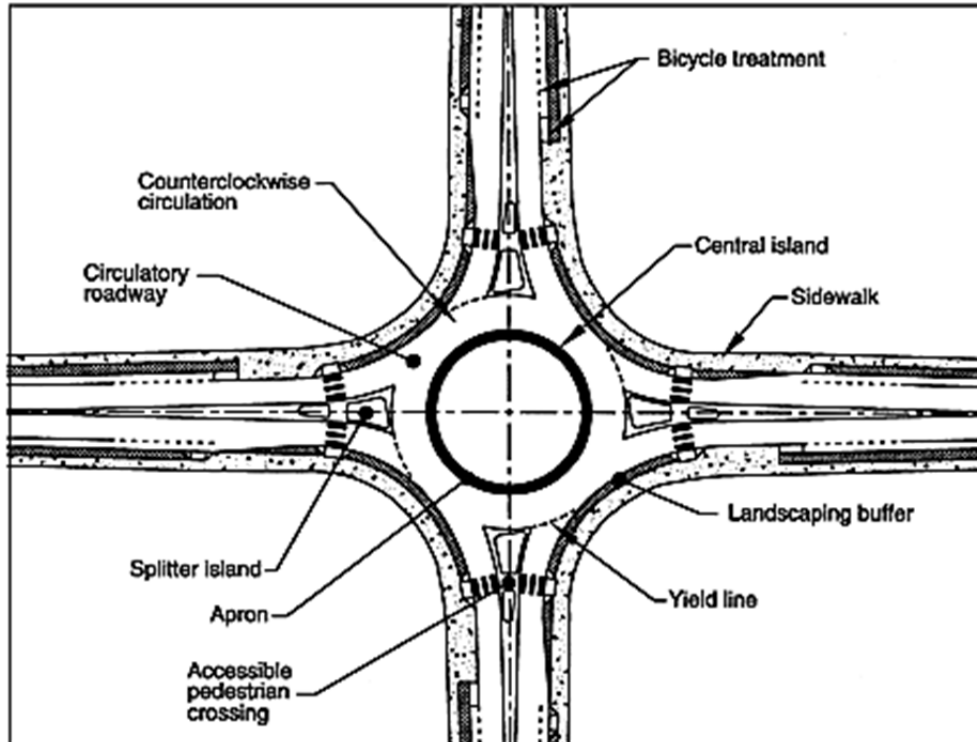

Figure 41: Pedestrian and Bicycle Treatment at Roundabouts

2.5.4 Wayfinding

Wayfinding is very important in this alternative since roundabouts are unsignalized. Signs are used to regulate, warn, and guide the vehicles through the path. The following signs should be used: yield signs on more than one approach, roundabout ahead signs, exit guide signs, and advanced diagrammatic guide signs. Regulatory signs include yield signs, “One Way” signs, and “Keep Right” signs. Yield signs are placed on all the entry ways of a roundabout. Single lane roundabouts only require one sign while dual lane roundabouts need one sign on each side of the entry. Lane use control signs are not required, but they may be utilized if seen applicable. Warning signs include circular intersection sign, yield-ahead sign, large arrow sign, chevron plate sign, and pedestrian crossing sign. Circular intersection sign are placed in each approach to designate the entry and exit lanes on the roundabout. Chevron plates and large arrow signs designate the direction of travel on the roadway. Guide signs include advance destination guide signs, exit guide signs, and route confirmation signs. Urban areas typically have fewer and smaller signs than in rural areas due to the low speed on the roundabouts. Pavement markings should be utilized to outline the entries and circulatory roadways. Entry and approach pavement markings are composed of yield lines, pavement work/symbol markings, lane use control markings, approach markings, pedestrian crosswalk markings, and channelization markings. Yield lines are located along the inscribed circle and delineate the entries onto the roundabouts. In order not to mislead drivers, lane lines are commonly not striped in the circulatory roadway. Sufficient lighting should be provided at roundabouts to enhance visibility and safety.

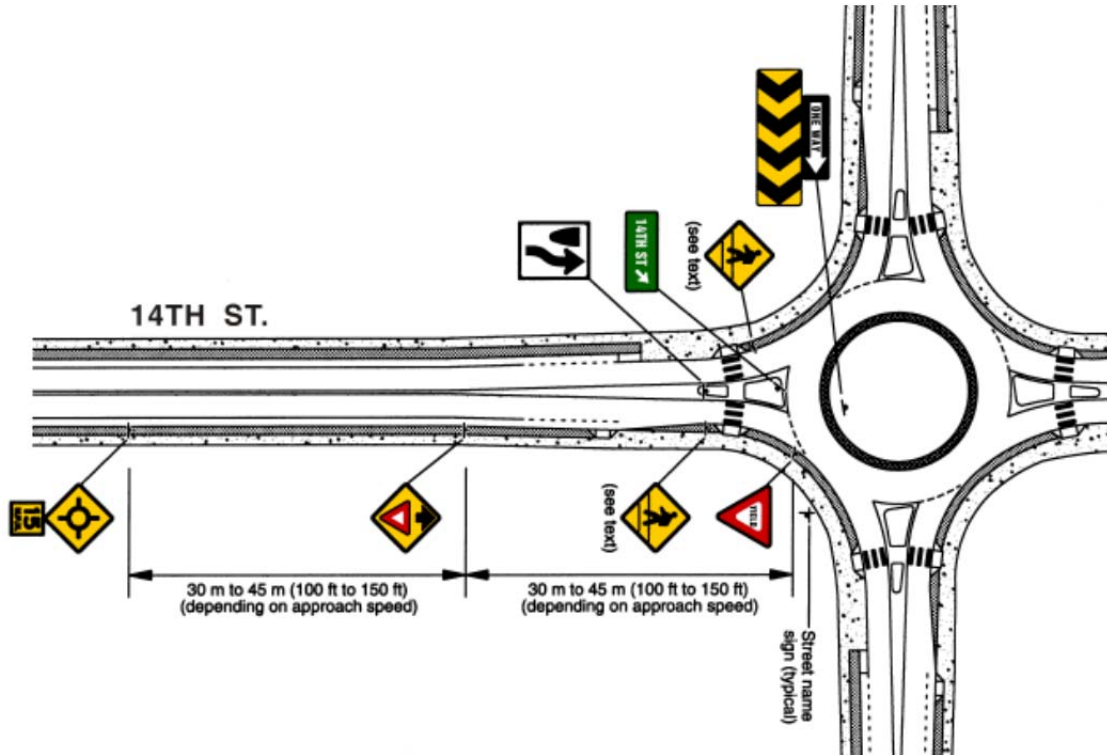

Figure 42: Typical Signing Plan for an Urban Roundabout

2.5.5 Signalization

Roundabouts are unsignalized yield-controlled alternatives. Typically entry ways are yield controlled, while the exit ways are free flowing and require no stops. There have been some cases where roundabouts have been signalized by metering one or more entries. This is not very common and should not be highly considered.

2.5.6 Benefit-to-Cost Ratio

Roundabouts have moderate benefit-to-cost ratios. Roundabouts vary in price from project to project due to the amount of work needed and new pavements added to the alternative. Multilane roundabouts are usually more costly to construct than traditional traffic signals while single lane roundabouts are sometimes comparable, because roundabouts require curb alterations and a



substantial amount of pavement. Other factors that make roundabouts costly are realignments, grading, drainage work, and extra landscaping. Intersections that require widening and extra turn lanes may be just as expensive as roundabouts or even more expensive. Roundabouts are more cost effective than interchanges with ramp terminals that require more roadway widths. Cost range from \$10,000 for retrofits to \$500,000 for new roundabouts. The National Cooperative Highway Research Program reported that the average cost of constructing a roundabout was about \$250,000 (Construction cost, land acquisition not included).

2.5.7 Performance Measures

Roundabouts result in less traffic delays and have shown to improve safety. Crash rates are reduced by 38% on roundabouts when compared to conventional intersections. The crash severity on roundabouts is also reduced; injury crashes are reduced by 76%. Fatal and incapacitating injuries have shown a large crash reduction. Land can be saved when building roundabouts instead of small conventional intersections.



2.6 Quadrant Roadway Intersections (QRI)

2.6.1 Area Type and Roadway Conditions

QRIs are suitable for urban and suburban busy roadways. They are used at severely congested intersections with very heavy through volumes and low to moderate left turns. The main objective is to remove left turns at the main intersection and reroute them to a connector road at one of the intersection quadrants.

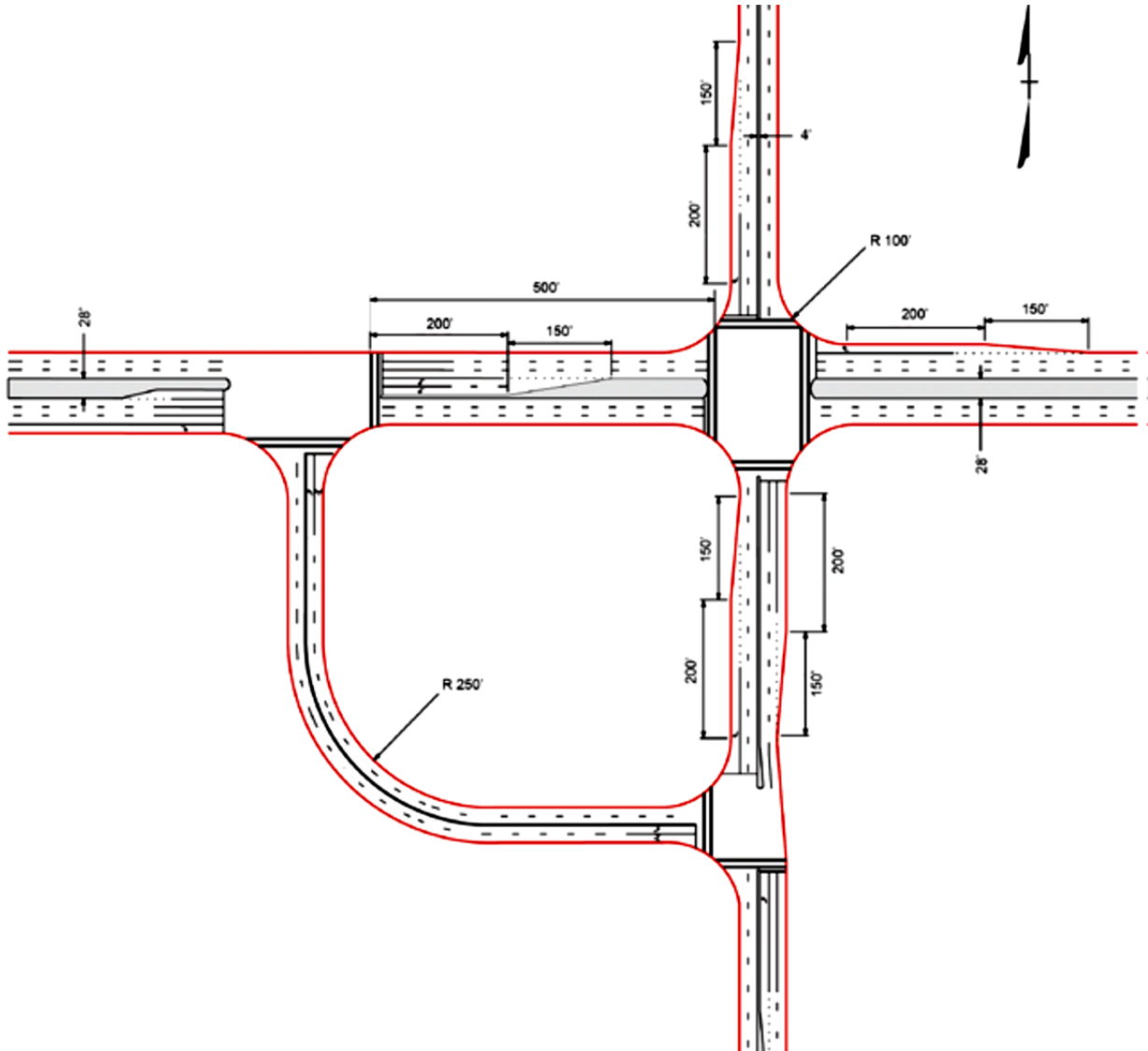

Figure 43: Typical QRI with Four-Lane Connecting Roadway

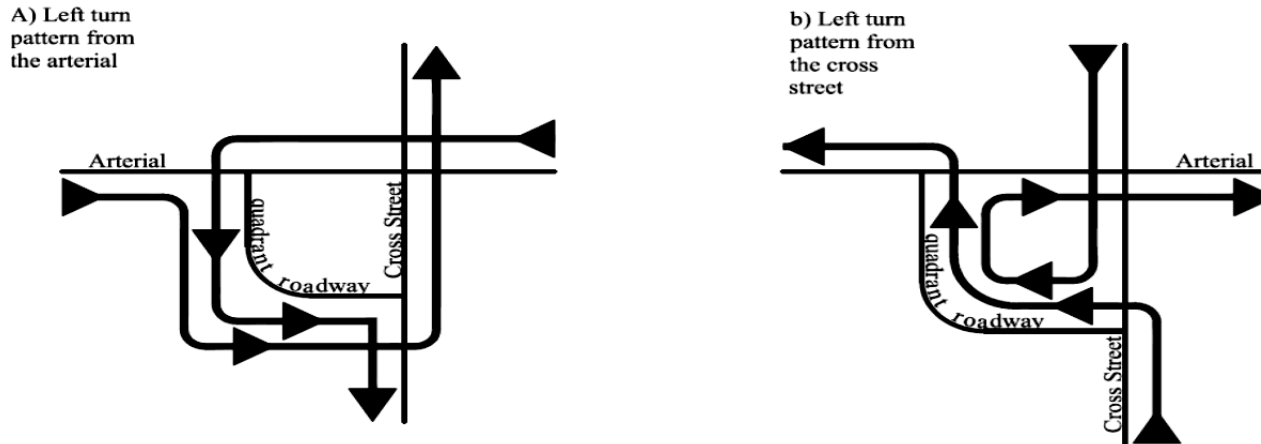

Figure 44: Left-Turn Movement at a QRI

2.6.2 Right of Way

A QRI can be among the least costly of the alternative intersections to construct and maintain, especially if there were existing streets to serve the function without the construction of a new roadway connector. Also, QRIs with one connecting roadway quadrant are the cheapest in terms of the right of way costs when compared to two-connecting roadway quadrants. At a minimum, a spacing of 500 ft from the center of the main intersection to the center of the secondary intersections is recommended. With 500-ft spacing between the main and secondary intersections and 90-degree intersection angles, there is sufficient area to fit a curve radius with 30 mi/h design speed on the connecting road. Assuming typical cross-sections, the size of the parcel inside the connecting roadway would be about 3.5 to 4.0 acres, which is suitable for a small commercial enterprise. In some cases, a four- to five-lane cross-section connecting roadway may be needed to accommodate very high traffic volumes. However, right-of-way widths and costs grow proportionally for the wider connecting roadways, but the delay savings and other benefits may be worthwhile.

2.6.3 Pedestrian and Bicyclist Interaction

QRIs work the same way as conventional intersections. However, it is easier and shorter to cross a QRI than a conventional intersection due to the removal of the left turn lanes at the main intersection. A QRI has only two or three signal phases, which shortens the cycle length and reduces pedestrian delay. Pedestrians may have to cross an extra crossing due to the connector road. As shown in Figure 45, the extra crossing might be on the east-west direction such as crossing F or on the north-south direction such as crossing I. Signal treatments for pedestrians with disabilities are similar to the conventional intersections. QRIs also assist pedestrians with visual or cognitive disabilities.

Similarly, bicyclists should find QRIs easier to negotiate and faster than a conventional intersection due to the relatively longer green times and progression. Bicyclists also have the choice to follow the vehicular paths at the main intersection or use the connector road which might have an extra travel distance or follow the pedestrians' crossings at the main intersection with no extra distance to travel.

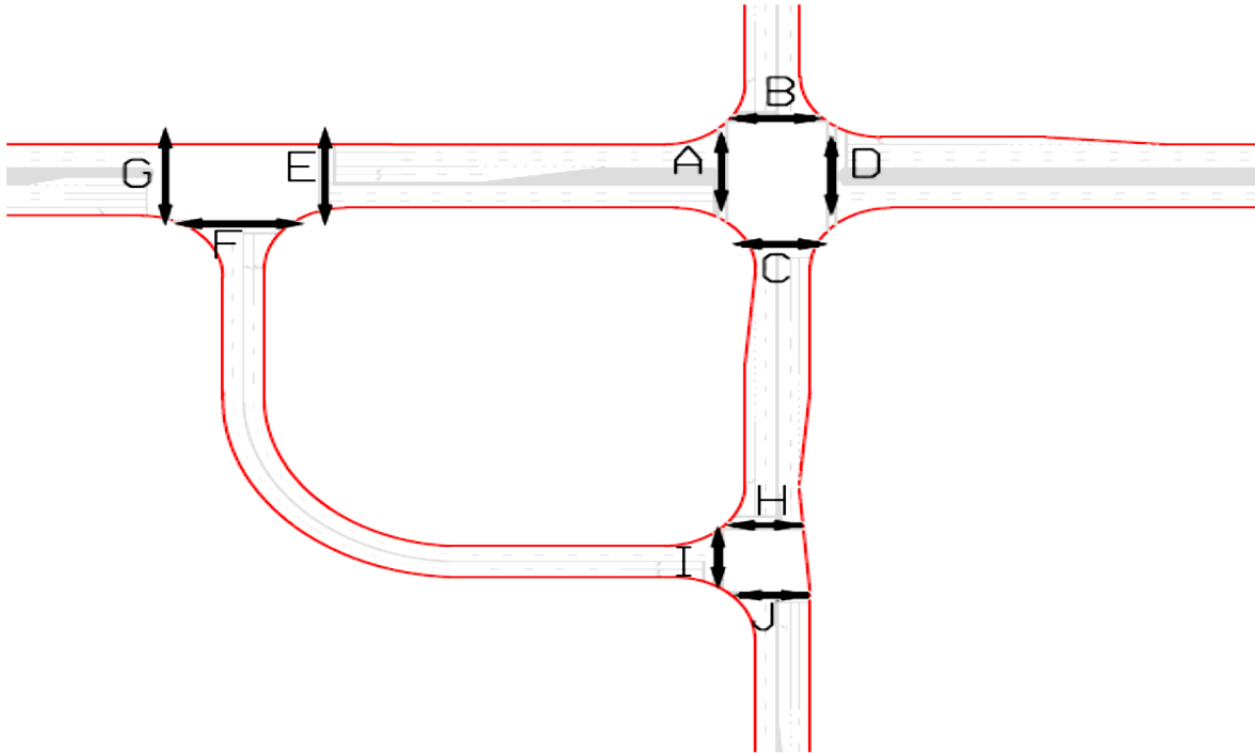

Figure 45: Crosswalks at a QRI

2.6.4 Wayfinding

All four direct left turns at a QRI are prohibited and rerouted to different locations compared to traditional intersection. The key issue at a QRI is to convey to drivers where they need to execute left-turn maneuvers and that a right-turn is needed first to complete the turn. Advanced overhead signs at the main and secondary intersections are needed to lead unfamiliar motorists through a QRI. Additional traffic control devices needed at QRIs include pavement markings, regulatory signs, and warning signs to ensure that no left turns or U-turns are made at the main intersection. To help drivers learn how to use the QRI, agencies should consider a public information campaign before the opening of a QRI. Press releases, flyers distributed and materials posted on the agency Web site also help residents to understand how to navigate through the intersection. The materials should include information to left turning drivers on how to follow the signs. It should also indicate that motorists will experience better intersection operations with the new design.

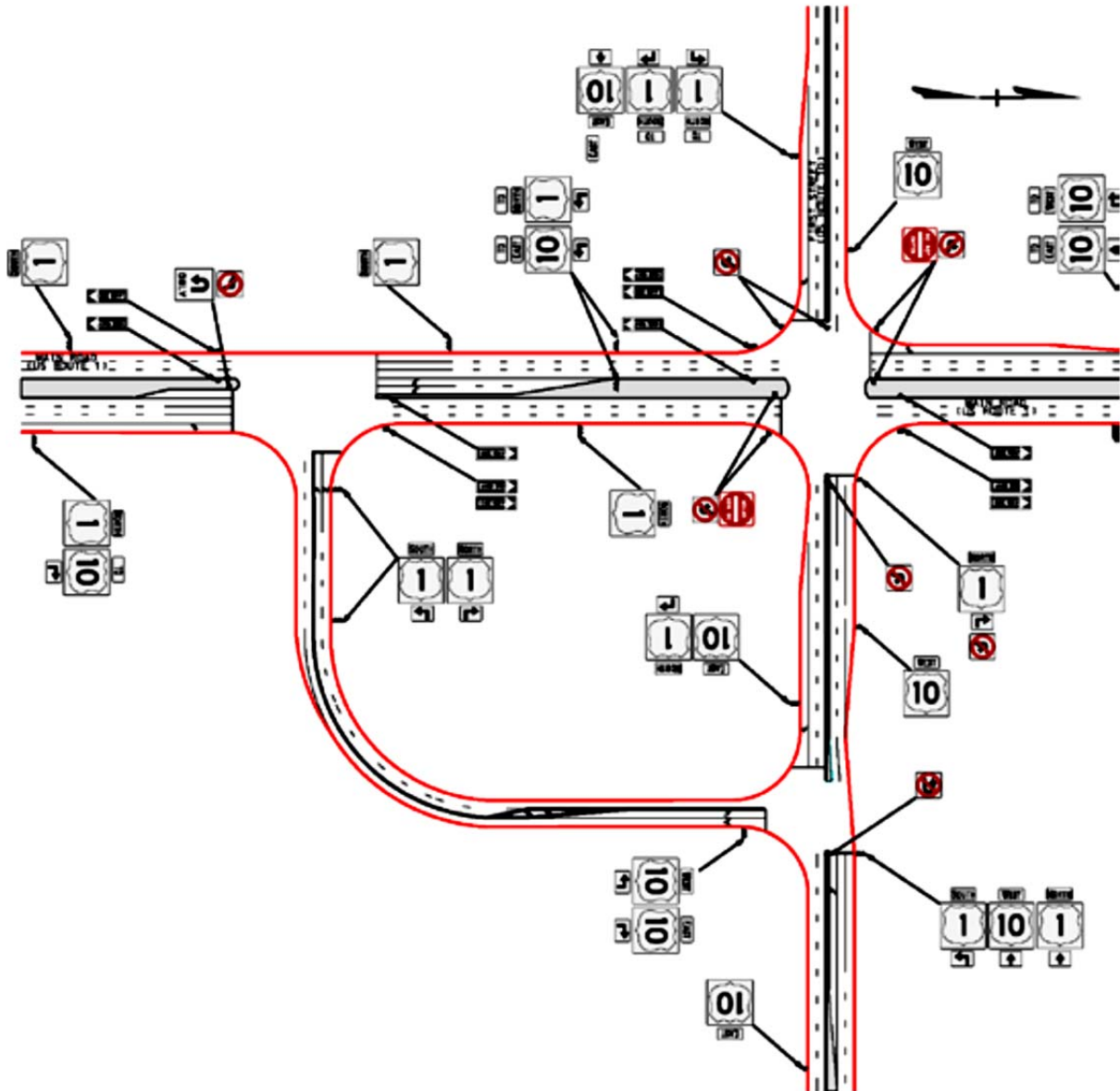

Figure 46: Typical Signing Plan for QRI

2.6.5 Signalization

QRIs usually have three signal-controlled intersections which include the main intersection reduced to a two-phase signal and two new T-intersections with three-phase signals at the ends of the connecting road. The main challenge in the signal design for a QRI is how efficient traffic can progress through the signals. QRIs provide an adequate amount of green time for the main streets through reduction of the cycle length to two-phases. QRI signals are also fairly easy to integrate into nearby signals along the arterials. However, if the analysis shows that longer cycles are needed at the proposed QRI, then it might not be the best option for this location.

In the three-phase scheme, the green phase for the main street at the main intersection extends through the first two phases. The scheme allows three of the four major street movements past the first signal that drivers encounter during one phase and past the second signal that they



encounter during the next phase. Only the southbound movement in the 3-phase scheme move through both signals in only one phase which produce positive results.

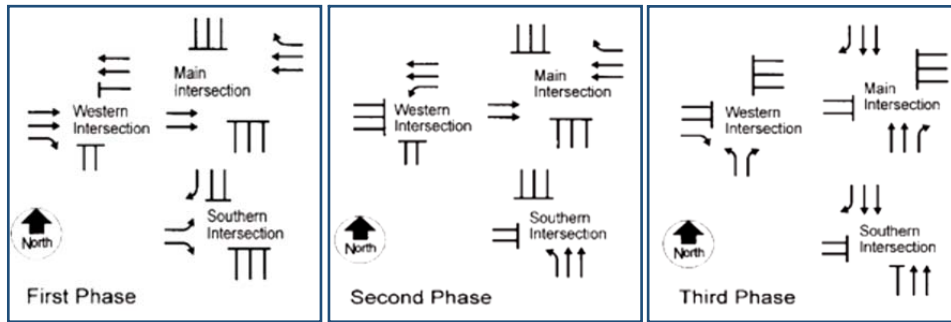

Figure 47: Typical Signal Operating Plan for QRI

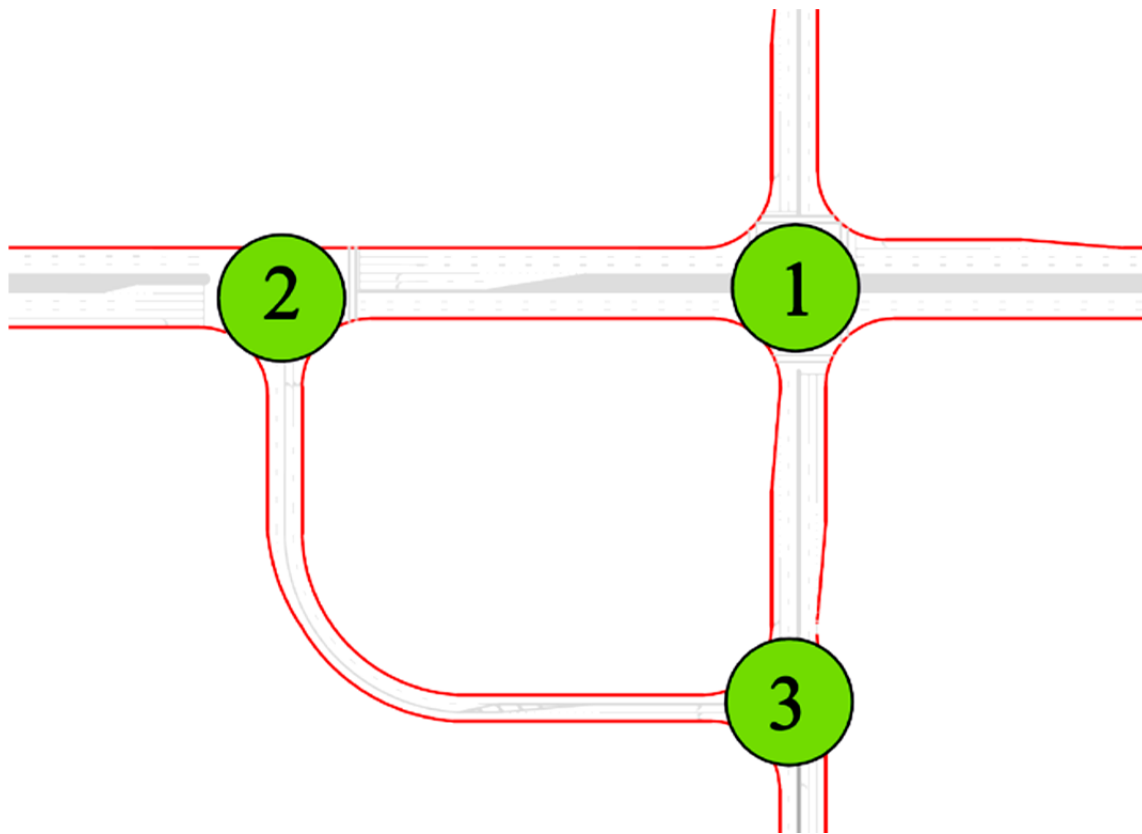

Figure 48: Typical Signal Locations at QRI

2.6.6 Benefit-to-Cost Ratio

QRIs offer moderate to high benefits over a conventional intersection although construction costs for QRIs are likely higher than a conventional intersection. Main components that are needed and add to the cost include the connector roadway, additional signals and overhead signs for the two extra intersections. On average, the connector roadway is about 880 ft (centerline to centerline), or 0.167 miles with 500 ft spacing between the main and secondary intersections. The average right of way is about 1.1 acres. Other costs are related to lighting, maintenance costs and enforcement needs especially during the first months of operations. The cost of the



connector roadway is the greatest cost and affects the total project cost depending on the available right of way. Some of the costs associated with the QRIs could be slightly compensated by the reduced widths at the main street intersection. Furthermore, project costs related to land acquisition and signalizations could be diminished substantially with the presence of an existing connector roadway on one of the quadrants of the main intersection.

2.6.7 Performance Measures

QRIs in general perform better than conventional intersections for moderate and balanced through volumes on the major road. QRI simulation results showed higher throughput and lower travel times when compared to conventional intersections. Results showed increase in throughput ranging from 5% to 20% with a 50% to 200% savings in travel times. QRIs increase operational efficiency through heavily congested intersections. QRIs are considered one of the most efficient at-grade intersection designs by the removal of the left turns from the main intersection and having a two-phase signal. A well-designed QRI improves intersection safety due to the lower conflict points in comparison to a conventional intersection. QRIs reduce traffic congestion at intersections in urban areas and could serve as a short-term solution until a grade-separated interchange is built.



2.7 Evaluation Matrix for Design Criteria of Alternative Intersection Designs

The following information on Table 16 is a compilation of the research presented in Chapter II. Each of the alternative intersection designs have differing parameters that have to be considered before their implementation at proposed field locations. Initial considerations to be made for the area type, roadway conditions and right of way. These categories are typical starting points to begin evaluating the proposed intersection treatment location. Other parameters to be considered include the pedestrian and bicycle impacts, wayfinding and the signalization patterns. These items become the major factors as design criteria are flushed out for the full design of the proposed treatment of the study intersection. Finally, the operational aspects and the cost-to-benefit ratio need to be assessed to ensure that the project is viable to be considered. The table, on the following page, summarizes the most important factors to be considered as advantages and disadvantages for each of the alternative intersection design treatments.



Table 16: Evaluation Matrix for Design Criteria of Alternative Intersection Designs

Criteria	Treatment	
	CFI / XDL	DDI
Area Type	Urban & Suburban areas	Urban, Suburban & Rural highway interchanges
Roadway Conditions	Heavy Lefts VIC > 0.80 LT Opp vol > 150,000 LT > 250 vphpl & opp vol > 500 vphpl Many signal phase failures LT spill beyond storage length	Heavy Lefts on & off freeway ramps VIC > 0.90 or at capacity Queue spillback onto ramps Heavy ramp volumes Many signal phase failures High crash location especially left turn crashes
Right of Way	Smaller footprint & cheaper than interchange Larger footprint than conventional intersection Crossover radii (150-200 ft) XDL can have 4 or 2 displaced lefts Adjacent land use access is affected 300-600 ft from crossover to main intersection Wider medians & lane widths (15 ft) at crossover	Small footprint - almost no additional ROW Retrofit for existing diamond interchanges Crossover intersection spacing (500-1000 ft) Typical crossover angle (40-50 degrees) up to 90 Wider lanes at crossover (14-15 ft) Recommended tangent after crossover (10-15 ft) Recommended tangent before crossover (15-20 ft)
Pedestrian Interactions	Crossing distance increase 1-stage or 2-stage crossings Need wider medians Refugee islands between LT & Thru lanes Special considerations to peds with disability Need signals at channelized right turns	Ped safety increases with ped activated signals 2-phase signals better serve ped movement More crossing time per phase serving peds Peds may not be aware of new traffic direction Peds walkway is either outside or center walkway Special considerations to peds with disability
Bicycle Interactions	Use traffic lanes as vehicles Use bicycle ramps on sidewalks Use shared paths on crosswalks Use bicycle box on far side of refugee islands	Marked bike lane throughout the DDI Separate bike way or multi-use path Use vehicular lane Use ped walkway (outside or center)
Wayfinding	Position signal heads above crossover lanes Signs placed 0.25 miles & 200 ft in advance Provide wrong way signage and pavement markings Consider overhead & post mounted signage Provide lane extension striping Provide lighting at conflict points Potential for wrong way movements	Low crossover angles increase wrong way movement Signs before & after crossover (250 ft in advance) Provide wrong way signage and pavement markings Consider overhead & post mounted signage Lane use arrows guide motorists better Provide lighting at conflict points Channelize in & out bound movements at crossover
Signalization	Up to 5 signals for full XDL with single controller Signals are usually coordinated Offset length determines signal phase Crossover lefts and minor street move together No RTOR is recommended but depends on the design No U-turn signs for thru movements Issues with flashing signals or loss of power	Up to 8 signals at conflict locations Unused green time increases with longer spacing Use of straight green arrows is recommended RTOR are not recommended Both cross over signals operate independently DDIs favor cross street through traffic phases Supplemental signal heads may be needed
Cost to Benefit Ratio	High benefit to cost ratio (can reach up to 11:1) Cost range from \$4-8 million Grade separation range from \$10-30 million	Very high benefit to cost ratio (up to 15:1) with no ROW Cost savings reach up to 75% compared to alternatives Retrofits range from \$3-8 million compared to \$20 million
Operational	Capacity along corridors increase by 20-50 % Average speed increases by 13-30 % Energy savings of 5-11 % HC, CO, and NOx emissions decreased by 1-6 % Fewer and less severe crashes Improved level of service	Capacity increases by 10-30% Delay is reduced by 15-60% Can accommodate twice the conventional left turn Left turn crashes are totally eliminated Total crashes are reduced by 50% Timely & cost effective solution
Advantages	Increase in capacity Decrease in delays, number of stops, conflicts, queues, and emissions Great for heavy left turns and thru traffic	Reduction of phases, conflicts, footprints, and construction cost Increases safety & Capacity Beneficial in heavy left & thru traffic
Disadvantages	Driver confusion Needs proper signage & signals Driveway access to adjacent businesses Challenges for impaired pedestrians and requires multistage crossings No U-turns	Lost time due to numerous phases Driver Confusion Concerns with access to adjacent parcels Longer path for pedestrians



Table 16: Evaluation Matrix for Design Criteria of Alternative Intersection Designs, continued

Criteria	Treatment	
	MUT	RCUT
Area Type	Urban, Suburban & Rural corridors	Mostly suburban & rural corridors
Roadway Conditions	Moderate to heavy through & moderate left turns High main line and low cross-street volumes Along corridors with wide medians Bulb-outs are used for narrow or no medians Partial MUTs can be used for minor streets Considered as a corridor treatment	High speed corridors Congested arterials Heavy mainline thru traffic Unevenly spaced intersections Safer form of stop/yield conditions Considered as corridor treatment
Right of Way	ROW varies from 139 ft for 4L to 165 ft for 8L U-turn loons minimize ROW needs Wide turning lanes & paved shoulders 15 ft/lane Directional Xover 400-600 ft from main intersection Min distance between crossovers (100-150 ft) Median widths (8-69) based on design vehicle Turning radii 70 ft or more are recommended	ROW from 137 ft for 4L to 161 ft for 8L Min ROW is 70 ft on mainline Min Minor street median is 6 ft Xover 400-800 ft from main int Channelized islands for farm equipment U-turn xover up to 0.5 mile apart Consecutive x-overs need min 100 ft
Pedestrian Interactions	Reduced number of conflicts Wide medians increase walking time and distance Cross during thru & right turns of minor street Sufficient green time to cross in 1-stage Mid-block xwalk can be at U-turn crossovers Special considerations to peds with disability	"Z" Xings are setup as diagonal path Xwalks are longer Channelized curbs assist peds Unsignalized movements are challenging Mid-block xwalk can be at U-turn crossovers Special considerations to peds with disability
Bicycle Interactions	Bicycle lanes or turn queue boxes are used Use traffic lanes as vehicles Use bike ramps on sidewalks Use shared paths on crosswalks as peds	Pass thru/across channelized island Can use buffered lanes or cycle tracks Can use the "Z" crossing (recommended) Use traffic lanes as vehicles
Wayfinding	Signs far enough to alert drivers for no lefts Detailed signs for U-turn crossover maneuver Use proper overhead and ground-mount signs "Fishhook" signs are used to direct vehicles Provide wrong way signage and pavement markings 2 guide signs before and at intersection Stop bars placed less than 30 ft & more than 4 ft	Signs alerting drivers for no thrus or lefts Overhead lane signs 350 ft in advance Extension pavement markings guide veh "Fishhook" signs used to direct vehicles ONE WAY & WRONG WAY signs needed Signs prohibiting parking on loons Merge controlled x-overs use flashing beacons
Signalization	Range of 3 to 5 signals for 4 legged int U-turn crossovers are signalized or unsignalized crossover min green needs to be longer Signal heads placed 40 to 180 ft beyond stop bar 2-phase signals are commonly utilized No RTOR recommended during peak times Cycle lengths range from 60-120 seconds	Range of 1 to 6 signals for 4 legged int U-turn crossovers are signalized or unsignalized 2/3 to 3/4 green time for thru movements signal heads placement are flexible if a side street is present, consider adding third phase to avoid conflicts No RTOR recommended during peak times Use of common cycle may cause delays
Cost to Benefit Ratio	Medium benefit to cost ratios experienced ROW & extra signalization increase cost Construction Costs range from \$1.5 to 20 million	High B/C ratio compared to grade separation ROW & extra signalization increase cost Construction Costs range from \$1 to 5 million
Operational	Capacity improves by 20-50% Throughput increases by 15-40% Travel time savings range from 10-40 sec/veh (17%) Average stops reduced by 20-40% Safety increases due to less conflicts Avg speeds increase by 25%	Throughput increases by 30% Travel time savings range from 25-40% Approx 1 min longer travel time Peak travel times decrease 75% crash reduction due to 50% less conflicts Avg speeds increase by 15%
Advantages	Reduced conflicts and construction costs Vehicle stops reduction & travel time savings Increase in throughput 30-45% Safer approach	Low number of conflicts Reduction of crash rate and severe crashes Safer approach Increase in throughput
Disadvantages	Longer average travel time for lefts Higher stopping time for left turns Requires wide medians Pedestrians crosses wide median in 2 stage manner	Sometimes it causes longer travel times Less efficient with heavy traffic on minor roads Longer path for pedestrians & more exposure to traffic



Table 16: Evaluation Matrix for Design Criteria of Alternative Intersection Designs. continued

Criteria	Treatment	
	Roundabout	QRI
Area Type	Urban, Suburban & Rural areas	Urban & Suburban busy intersections
Roadway Conditions	Capacity is limited Single lane up to 25000 veh/day Multi lane up to 45000 veh/day Single lane have 20-25 mph speed Multi lane have 25-30 mph speed Rural areas have higher speeds	Heavily congested intersections Heavy thru but low to moderate lefts Heavy lefts require wider connectors Many signal phase failures Intersection operating at capacity High crashes for left turns
Right of Way	ICD for single lane is 100-150 ft ICD for multi lane is 150-250 ft Entry lane width range 14-16 ft Entry radii range 33-98 ft Exit radii no less than 50 ft Flare length (urban 80/rural 130 ft) Freeflow Bypass lanes if no peds	Average ROW is about 1.1 acres 500 ft distance from main int needed Need curve to accommodate 30 mph Typical quadrant area is 3.5-4 acres 4-5 roadway connector may be needed Existing connectors reduces ROW costs One connector cheaper than 2 or 3
Pedestrian	Xwalk is 1-3 car lengths 2-stage xings Min splitter length 50/width 6 ft Sidewalk set back about 5 ft May need 6-9 sec gap to cross Ped signals needed for high activity	Shorter distance with LT removals 2-3 signal phases reduce ped delays Peds may cross extra crossing LT from connector rd affect peds Peds treated same as conventional int Special considerations to disabled peds
Bicycle Interactions	Use travel lanes in single lane Roundabout Use ped sidewalks & xwalks No bike lanes due to conflicts Bikes slow down speed to 15 mph	Easier to negotiate & faster Relatively longer green times Can use the vehicular path Can use pedestrian xings
Wayfinding	"Yield" signs ahead on all approaches "Roundabout Ahead" signs Exits are free flowing Advanced destination guide signs Route confirmation signs Lane lines not striped inside Rbt Sufficient lighting is needed	All 4 LT are prohibited Advanced overhead signs needed Pavement markings are needed Warning signs for "NO LEFT" needed Consider public information campaign Signs showing LT need RT first Lighting is recommended
Signalization	Usually unsignalized yield-control Yield signs ahead on all approaches Entry lanes are yield controlled Exit lanes are free flowing Lane markings for lane utilization High ped activity need signalization Can be metered at 1 or more entries	Up to 3 signals 2-T intersections need 3-phase signal Main intersection reduced to 2-phases High ped activity need exclusive ped phase Signals integrated with nearby signals Provide adequate amount of Thru green Longer cycles (> 90 sec) not recommended
Cost to Benefit Ratio	Moderate B/C ratios Cost effective compared to interchanges Cost range from \$10,000 to 0.5 million	Moderate to high B/C ratio based on ROW Connector costs are the greatest Reduced width at main int compensate ROW
Operational	Improved throughput compared to int Result in less traffic delays Improves safety Crash rates decrease by 38% Injury crashes reduced by 76% Avg speeds are maintained at 25 mph	Increase in throughput from 5-20% Travel time savings of 50-200% Delays & max queues reduced significantly Improves safety due to less conflicts Average speeds increase by 14% Most efficient at-grade intersections
Advantages	Reduction in queues and delays Reduction in number of conflict points and potentially less number of crashes and severe injuries	Short average cycle length Reduction in travel time, delays, queuing for thru traffic Reduction in conflicts and pedestrian crossing times
Disadvantages	Roundabouts near operating capacity aren't efficient. Adjusting the deflections and speed reductions can be difficult depending on the intersection geometry	Higher average speeds Noncompliance of left turners Additional signalization needed Left turn travel distance is increased Additional right of way for quadrant & extra cost for connecting roadway



III- PILOT PROJECT ASSESSMENT

3.1 Continuous Flow Intersection (CFI)

3.1.1 Study Intersection and Roadway Conditions

The CFI intersection eliminates the conventional left turns at the main intersection by displacing the left turn lanes onto the opposing side of the road. The crossover occurs several hundred feet before reaching the main intersection. The vehicles wait on a signalized bay that eventually cross them over the opposing through lanes onto the left side of the road at a separate signalized intersection before the main intersection, sometimes referred to as secondary intersection. Both intersections are operating in a coordinated manner. At the main intersection, both the through and left turning traffic operate simultaneously which increase the efficiency and maximize throughput.

The intersection under study is located in Orlando, Florida along Osceola Parkway at US 441 as shown on Figure 49. The intersection is 4-legged with Osceola Parkway running in the east-west direction while US 441 running north-south. Osceola Parkway is a 4-lane divided principal arterial west of US 441 and 6-lane divided principal arterial east of US 441 with posted speed limit of 45 mph. Similarly, US 441 functions as a 4-lane divided principal arterial south of Osceola Parkway and 6-lane north of Osceola Parkway with 45 mph speed limit. However, within the vicinity of the intersection, US 441 exhibits six lanes south of Osceola Parkway. The laneage at the intersection consists of two exclusive left turn lanes, two through lanes and one exclusive right turn lane on the east-west approaches, and two exclusive left turn lanes, three through lanes and one exclusive right turn lane on the north-south approaches. All four approaches have dual left turn lanes and exclusive right turn lanes with different storage lengths ranging from 300 to 500 feet as shown in Table 18 & Table 19. The left turn movements operate with protected phases only and the northbound and southbound right turn lanes are channelized with free movements. This intersection was selected for three main reasons. First, the intersection is experiencing recurring congestion in the PM peak hour and is operating near capacity with volume to capacity ratio closer to 1.00 due to the fact that there are two heavy conflicting movements; southbound and westbound. Second, the intersection turning movements are unbalanced especially during the peak hour. Third, both intersecting roadways are major roads with no minor road consideration. Therefore, in search for a plausible solution to mitigate the intersection congestion especially for future conditions, CFI alternative was investigated as the build scenario with different configurations and compared to the Conventional Intersection (CI) as the no-build scenario.



Figure 49: Study Intersection – Osceola Parkway at US 441 (Orlando, FL)

3.1.2 Right of Way

CFI's footprint is somewhat larger than conventional intersections and may result in wider streets at some locations but require less right of way than interchanges or partial grade-separation. Signalized bays are used to allow vehicles to cross onto the opposing through lanes. Wider medians may be required with this alternative at the signalized bays but could be tapered back to the original width at the main intersection. Medians are typically 10 ft long by 10 ft wide and are used as refuges for pedestrians. Refuge islands must be large enough to accommodate bikes, strollers, and pedestrians. The CFI can have single or dual left turn crossover lanes and two to three through lanes per direction. Lane widths are usually wider for through tangent roadways than tangent sections. Four legged CFI intersections can have four displaced left turns known as full CFI as shown in Figure 50, or two displaced left turns on the major street known as partial CFI as shown on Figure 51. Cross slopes may be provided at the crossover intersection. Left turning vehicles shifts from a 2% slope to the outside over to a 2% slope to the other side of the road through S-curves. The spacing between the upstream crossover and the main intersection ranges from 300 to 600 feet depending on the demand.

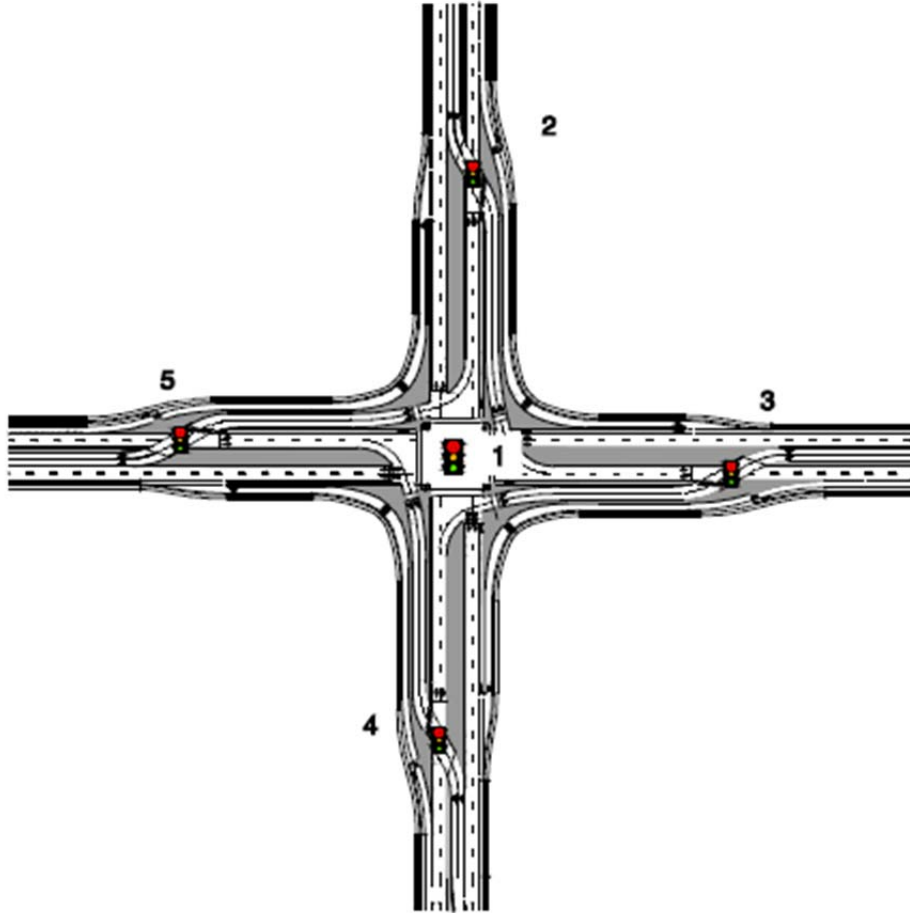

Figure 50: Full CFI Intersection on All Approaches

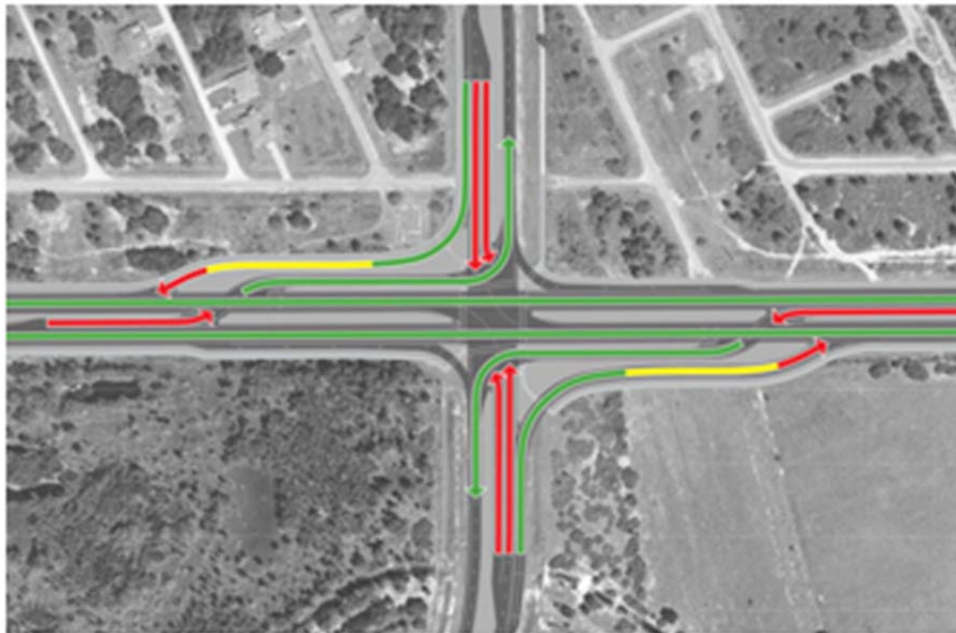

Figure 51: Partial CFI Intersection on East and West Approaches



3.1.3 Pedestrian and Bicyclist Interaction

Pedestrian crossing times have to be optimized in order to achieve true benefits. Wider streets cause longer pedestrian crossing distances and increase the time it takes for bicyclist to ride through. Pedestrian islands provide refuge along the crosswalks between the crossover left turns and through lanes. Crosswalks allow pedestrians to move from the channelization to the outer portion of the intersections. These crosswalks across the channelized right turns can be implemented with or without signals. If multiple right-turn lanes are provided at the intersection then the crossing should be signalized. There are two ways to operate and control pedestrian crossings:

- 3- Use signals at channelized right turns to ease the crossing of the right turn lanes. The pedestrians continue on to the first refuge island that is located between the crossover left turns and the through lanes. During pedestrian phases, pedestrians proceed to the opposing side of the road. (Note: Right turn on red are prohibited in this case)
- 4- The displaced left turns can yield to pedestrians using the crosswalk. This will allow the pedestrians to cross in one stage. However it is not a recommended practice.

Accessibility to pedestrians with disabilities and vision and/or mobility impairments should be accounted for. The Americans with Disabilities Act (ADA) and the Public Right-of-Way present policies and guidelines for intersections that accommodate all pedestrians. Pedestrian walkways must be delineated through landscaping, curbing, or fencing in order to accommodate vision-impaired pedestrians. Reasonable slopes should be provided for wheelchair users and strollers. Curb ramps and detectable warning surfaces at the edge of sidewalks should be provided. Locator tones and audible speech messages need to be provided at pedestrian signals to assist blind pedestrians. Push buttons need to be accessible by wheelchairs. The crosswalk widths should be wide enough to allow pedestrians and wheelchairs to cross without delays.

DXLs allow the option of using bicycle paths with separate lanes or shared used paths. Right turning vehicles and bicycles typically share the travel lanes. However, bicycle lanes or bicycle boxes may be utilized to prevent conflicts between bicyclist and right turning vehicles. The three ways bicyclist can complete left turns on this alternative are:

1. Using the traffic lanes as passenger cars to make the turns.
2. Using bicycle ramps on sidewalks or shared paths on the cross walks.
3. Using a bicycle box in front of the far side refuge. This refuge island will be located between the through and displaced left turn lanes which are a two-stage crossing.

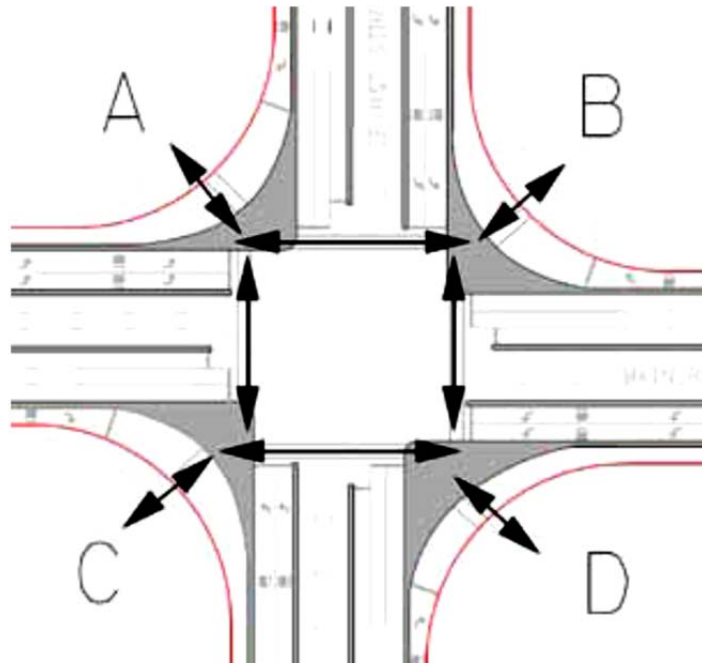

Figure 52: Typical Pedestrian Movements at CFI Intersection

3.1.4 Wayfinding

Wayfinding is highly needed due to the complexity of the alternative designs. Appropriate lighting must be used at intersections for pedestrian and bike safety. Green stripes on pavement can be implemented to indicate bicycle continuation lane. Wrong way warning signs, stop bars, curb lines, and pavement markings need to be utilized to avoid confusion and promote safety. Left turning signs are needed in advance to remind drivers about the lane crossover. Since these left turn pockets for the crossover are positioned well in advanced, signs must communicate with the vehicles to position themselves in the proper lane(s). Lane extension striping should be utilized to guide vehicles through the main and crossover intersections. It was also found that the words “KEEP CLEAR” on the pavement markings beyond the minor street stop bar prevent stop bar overruns.

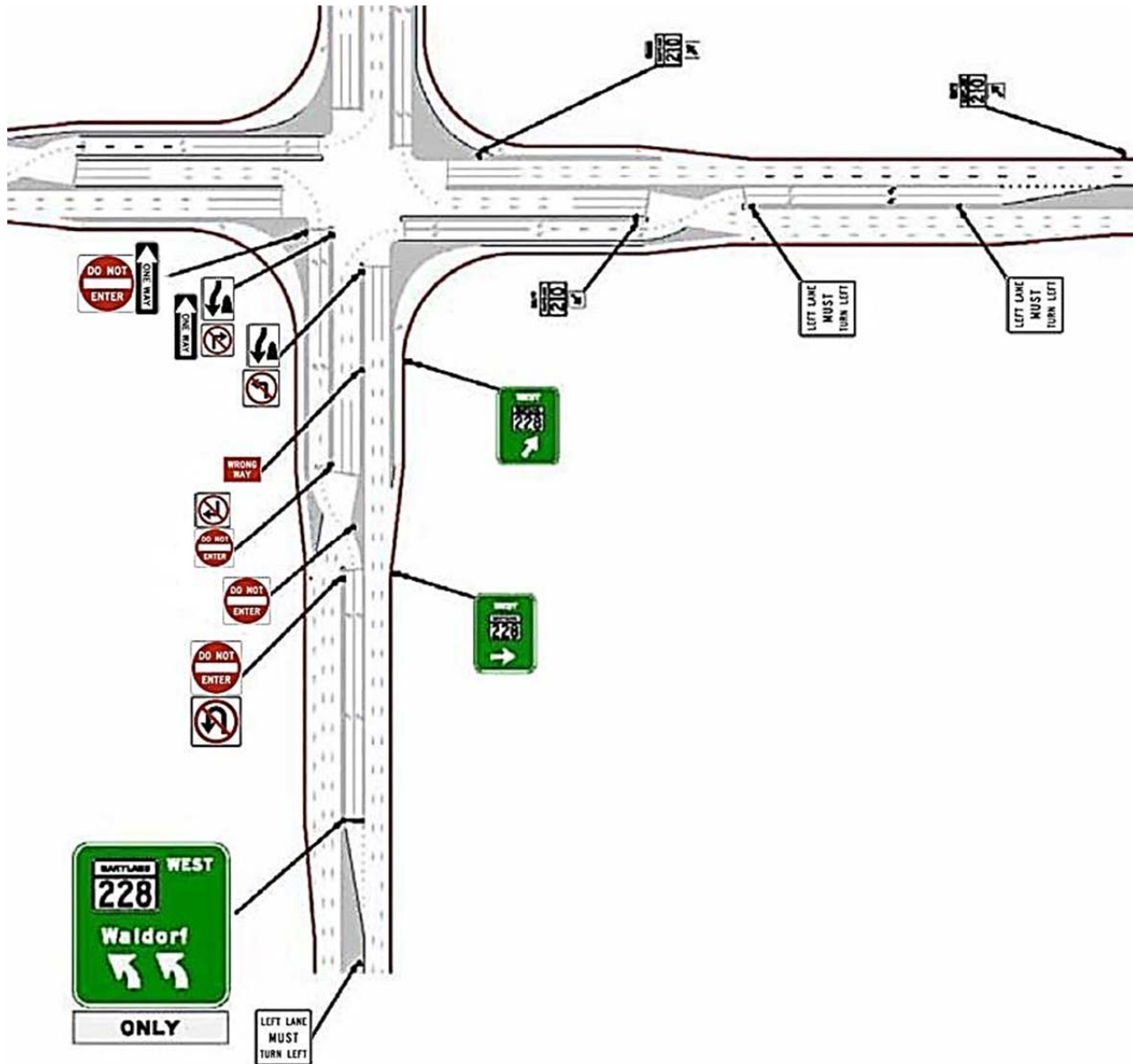

Figure 53: CFI Signing and Marking (Maryland Practice)

3.1.5 Signalization

Additional signalization is provided at the secondary intersections to allow vehicles to crossover to the opposing side. CFI operates as two phase signal with short cycle lengths. Two phase signals provide flexibility for progression and lead to reduced delays and shorter queues. Optimal cycle lengths are typically between 60 and 90 s. At a partial CFI intersection that handles minor road left turns at the main intersection, the signal control at the main intersection operates with three signal phases and cycle lengths are typically between 80 and 110 s. Signalized right turns as part of the crossover signal can eliminate downstream weaving and merging problems. Intersection spacing influences signal phase time for left turns. CFI can consist of up to five signalizations that are controlled by separate controllers or a single controller. The crossover upstream of the main intersection for the left turning vehicles may have a green light at the same



time as the minor street movements are occurring. In regards to left turn crossovers, offset length determines the max signal phase length. Using pedestrian signals at channelized right turns can ease the pedestrian crossings. At the CFI, efficiency in signal operation is achieved by simultaneously providing safe passage for left turns and through movements from opposing approaches. This is achieved by displacing left turns to the outside of conflicting through movements in advance of the intersection and reallocating green time to heavier through movements. Another component of the efficiency gain at the CFI is to ensure that the left turn signal at the main intersection turns green as the vehicles approaching from the upstream crossover signal arrive at the main intersection.

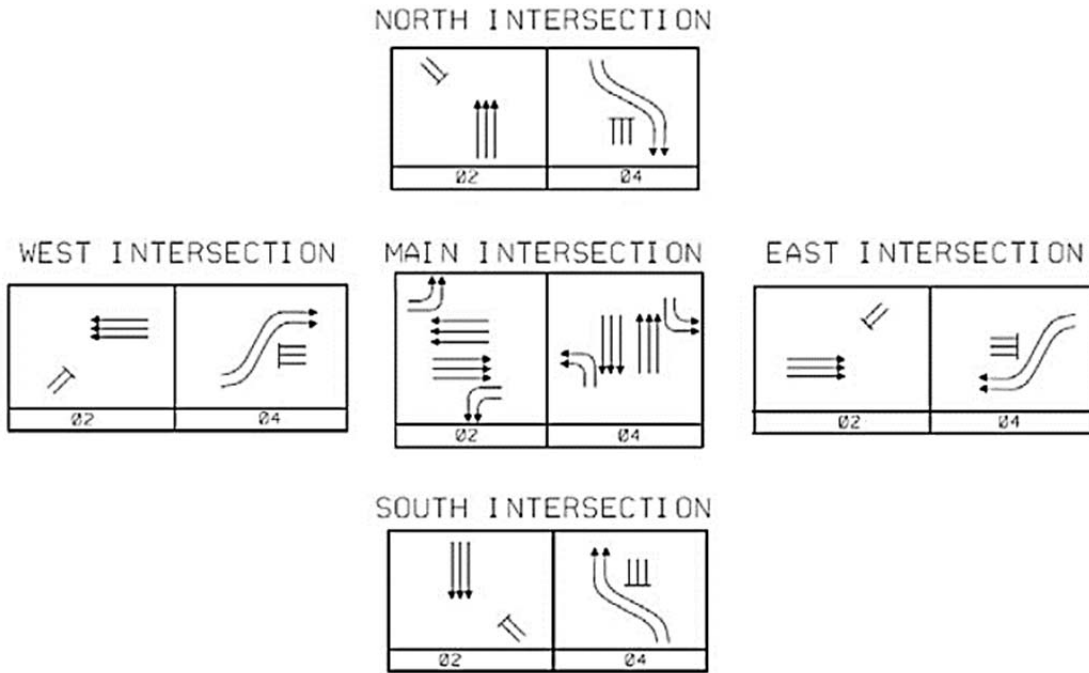

Figure 54: Typical 2-Phase Signal Operating Plans at CFI

3.1.6 Operational Performance

3.1.6.1 Traffic Scenarios

Field data was collected for the existing year 2015 conditions for the study intersection to facilitate the calibration process of the conventional intersection. Future conditions were then investigated for the design year 2035 assuming that the CFI alternative for the build scenario is designed for 20 years. The volumes were grown by 40% based on an average growth rate of 2% per year for 20 years to reflect future year 2035 conditions. Furthermore, the CFI alternative was investigated for four different scenarios; partial CFI on the east-west approaches, partial CFI on the north-south approaches, partial CFI on the north and east approaches and full CFI on all four approaches. Also, the impact of increasing volume on the intersection performance was considered by modeling the unbalanced volumes with 10% increment resulting in five different traffic scenarios. The final experiment resulted in $5 \times 5 = 25$ multilevel factorial design as



summarized in Table 17. It should be noted that both the conventional and CFI intersections were initially modeled in Synchro to calculate and compare the cycle length, splits and optimize the signals. VISSIM was then used to compare between the different CFI intersection configurations as well as the conventional intersection performance. Intersection performance measures included: total delay time per vehicle, overall throughput, average speed, 95% queue length and overall level of service (LOS). The vehicles configuration included 2% heavy vehicles on all approaches. For comparison purposes, the same turn bay lengths shown on Table 18 as the conventional intersection were used for the left turns upstream of the displaced cross over junctions. In all of the CFI scenarios, the cross over displaced left turn junctions (2, 3, 4, and 5) were located 500 feet upstream of the main intersection (Junction 1). Also, the same right turn bay lengths were used for the right turns at the main intersection. A 45 mph was used on both approaches to reflect speed limits along the roadways. For the traffic signals, a 6 second minimum initial time, 4 seconds of yellow and 1 second of all red was used in all phases. The simulation was run for 60 minutes with additional warm up period of 15 minutes in each scenario. A total of five runs with different seeding values were completed for each scenario and the average of the runs was reported.

Table 17: Design of Experiment

Scenario	Conventional Intersection (CI)	Partial EW CFI - Junctions 3&5	Partial NS CFI - Junctions 2&4	Partial EN CFI - Junctions 2&3	Full CFI - Junctions 2,3,4&5
Existing Year 2015	100%	100%	100%	100%	100%
Future Year 2020	110%	110%	110%	110%	110%
Future Year 2025	120%	120%	120%	120%	120%
Future Year 2030	130%	130%	130%	130%	130%
Future Year 2035	140%	140%	140%	140%	140%

3.1.6.2 Unbalanced Traffic Flow

The eastbound and northbound turning movement volumes totaled 1,443 and 1,327 vehicles per hour (vph), respectively. On the other hand, the westbound and southbound turning movement volumes amounted to 1,743 and 1,741 vph respectively. Therefore, the heaviest traffic movements were conflicting which affects the operation of the intersection resulting in higher delays and less capacity. It was also determined that the east-west volumes were heavier than the north-south volumes. To accommodate this type of unbalanced traffic distribution patterns, a hybrid design that replace one or two legs in a conventional intersection with CFI design is often adopted. Such hybrid designs are known as partial CFI intersections. Therefore, the following



designs were investigated to determine if a partial CFI design would be sufficient to accommodate the unbalanced future traffic flow or a full CFI is needed:

1. Two-leg Partial CFI (Type A): displaced left turn legs on the east and west approaches of Osceola Parkway. The other two legs have the same geometry as the conventional intersection.
2. Two-leg Partial CFI (Type A): displaced left turn legs on the north and south approaches of US 441. The other two legs have the same geometry as the conventional intersection.
3. Two-leg Partial CFI (Type B): displaced left turn legs in two perpendicular directions, on the north and east approaches of US 441 and Osceola Parkway respectively since they exhibit the heaviest movements. The other two legs have the same geometry as the conventional intersection.
4. Four-leg Full CFI: displaced left turn legs are on all four approaches

3.1.6.3 Signal Optimization Limitations

After calibrating the simulation model with field conditions, the VISSIM simulation was run for the five different volume levels for the CI and CFI scenarios after developing the near optimal signal settings from Synchro. In each scenario, numerous trials were conducted to arrive at the optimal signal settings and determine the optimal output values. As mentioned in the literature, So far, there is no general model for optimization of signal timings of the whole intersection group or the offsets between sub-intersections and primary intersection. Moreover, Synchro is not the best optimization tool for unconventional intersections. However, it helps as a starting point then manually fine tune the timings to arrive at the best setting. It should be noted that signal phasing and timing is one of the most significant factors that affects the operation of the CFI intersection and can severely nullify its operational benefits.

At a partial CFI (Type A) intersection, the signal control at the main intersection operates with three signal phases and cycle lengths are typically between 80 and 110 seconds at low volume levels. However, Type B intersections operate with four signal phases at the main intersection. The literature suggests using higher cycle lengths especially in high traffic demands. Therefore, cycle lengths between 50 and 200 seconds were considered in all the scenarios. Also, the traffic signal at the main intersection and the sub-intersections were controlled by a single controller in all scenarios. The crossover upstream of the main intersection for the left turning vehicles had a green light at the same time as the cross street movements are occurring. In regards to left turn crossovers, offset length determines the max signal phase length. At the CFI, efficiency in signal operation is achieved by simultaneously providing safe passage for left turns and through movements from opposing approaches. This is achieved by displacing left turns to the outside of conflicting through movements in advance of the intersection and reallocating green time to heavier through movements. Another component of the efficiency gain at the CFI is to ensure that the left turn signal at the main intersection turns green as the vehicles approaching from the upstream crossover signal arrive at the main intersection to minimize left turn delay.



3.1.6.4 Analysis and Results

Due to the fact that CFI intersections operate with multiple signals, delay measurements were aggregated for each movement as illustrated in Figure 55. The aggregation method allows apples to apples comparison between a conventional intersection and a CFI alternative (UDOT CFI Guideline 2013). Tables 18 and 19 summarize the performance measures by movement for each of the alternatives for the existing conditions base scenario which is at the 100% volume level as well the design year scenario which is at the 140% volume level, respectively. At the movement level, critical movements that controlled the cycle length and green timings included the westbound left (WBL), southbound left (SBL), eastbound through (EBT), westbound through (WBT) and the southbound through (SBT) movements. The cycle length and the splits were optimized to accommodate these heavy conflicting movements in each scenario which were operating at v/c ratio greater than 1.00. For example, as shown on Table 18, the WBL turning movement was failing in the existing conditions in the CI scenario with delay and queue length values greater than the CFI scenarios. The percent reduction in delay for the WBL in the CFI scenarios compared to the CI scenario ranged from 30-40%. Similarly, the WBL queue length showed percent reduction in the CFI scenarios ranging from 25-40%.

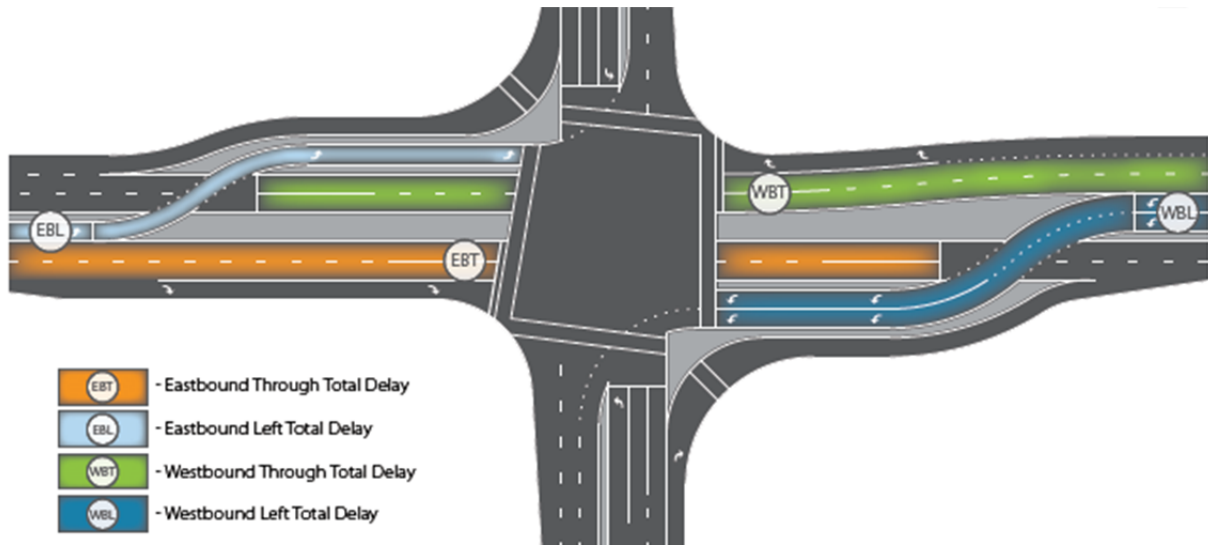

Figure 55: Aggregate Delay Calculation at CFI (UDOT CFI Guidelines 2013)



Table 18: Performance Measures Comparison by Movement – Volume Level 100%

Movement	Volume (vph)	Storage Length (ft)	Conventional Int			Partial EW XDL			Partial NS XDL			Partial EN XDL			Full XDL		
			Delay / Veh (sec)	LOS	95th % Queue (ft)	Delay / Veh (sec)	LOS	95th % Queue (ft)	Delay / Veh (sec)	LOS	95th % Queue (ft)	Delay / Veh (sec)	LOS	95th % Queue (ft)	Delay / Veh (sec)	LOS	95th % Queue (ft)
EBL	140	325	51.3	D	360	48.5	D	119	40.9	D	327	66.5	E	386	48.6	D	143
EBT	1160		56.4	E	552	48.9	D	404	45.5	D	469	45	D	457	54.9	D	481
EBR	143	325	11.4	B	342	9.5	A	207	23.3	C	291	17.4	B	372	0.9	A	34
WBL	433	375	88.1	F	351	54.9	D	227	51.8	D	201	62	E	267	55.7	E	253
WBT	1051		25.7	C	251	36.9	D	322	25.5	C	300	41.8	D	419	29.2	C	358
WBR	259	500	4.3	A	84	6.5	A	111	22.5	C	243	24.5	C	220	1.4	A	49
NBL	209	375	112.2	F	225	49.5	D	208	34.1	C	121	97.2	F	181	52.3	D	128
NBT	687		56.2	E	247	59.6	E	285	60.2	E	434	23.5	C	193	25.8	C	163
NBR	431	300	5.3	A	0	4.8	A	0	49.5	D	443	3.6	A	88	5.6	A	92
SBL	445	500	64.3	E	292	40.3	D	236	35.1	D	196	38.4	D	287	44.6	D	278
SBT	1051		44.4	D	279	40.4	D	298	88.4	F	416	64.3	E	416	32.4	C	451
SBR	245	300	5	A	0	22.6	C	0	3.6	A	0	7.6	A	226	16.9	B	103

Table 19: Performance Measures Comparison by Movement – Volume Level 140%

Movement	Volume (vph)	Storage Length (ft)	Conventional Int			Partial EW XDL			Partial NS XDL			Partial EN XDL			Full XDL		
			Delay / Veh (sec)	LOS	95th % Queue (ft)	Delay / Veh (sec)	LOS	95th % Queue (ft)	Delay / Veh (sec)	LOS	95th % Queue (ft)	Delay / Veh (sec)	LOS	95th % Queue (ft)	Delay / Veh (sec)	LOS	95th % Queue (ft)
EBL	196	325	121.3	F	540	150.3	F	455	70.3	E	528	310.1	F	511	119.9	F	488
EBT	1624		108.6	F	716	97.3	F	483	145.2	F	564	79.4	E	682	63.3	E	500
EBR	200	325	51.5	D	586	27.6	C	531	107.7	F	533	35	D	533	1.1	A	59
WBL	606	375	396.5	F	1243	66.7	E	377	219	F	478	232.5	F	474	97.8	F	433
WBT	1471		54.8	D	620	69.2	E	515	232.2	F	1636	91.1	F	1870	48.5	D	551
WBR	363	500	11.7	B	501	10.6	B	201	113.5	F	792	2.3	A	73	1.4	A	58
NBL	293	375	435.5	F	928	197	F	497	113.2	F	220	61.3	E	342	209.2	F	405
NBT	962		107.8	F	573	278.3	F	1264	77.3	E	471	68.7	E	360	39.9	D	284
NBR	603	300	8.7	A	277	4.7	A	155	79.2	E	356	12.5	B	318	9.1	A	119
SBL	623	500	384.7	F	1400	257.5	F	586	59.6	E	371	140	F	507	193.7	F	540
SBT	1471		79.2	E	605	233.2	F	1489	58.1	E	519	78.6	E	605	58.8	E	560
SBR	343	300	13.8	B	514	45.6	D	218	8.8	A	417	16.6	B	513	65.8	E	423



The SBL turning movement also showed between 30-45% reductions in delay. When comparing the delay and queue length of the same movements in the design year conditions with volume level 140%, the benefits gained from the CFI scenarios especially the EW CFI, EN CFI and Full CFI were almost double the CI existing conditions scenario. The analysis also showed that the partial NS CFI scenario did not show much benefit especially when compared to the rest of the CFI scenarios. This was attributed to the critical movements being mostly in the east-west direction except for the SBL and SBT movements that benefited the most. Conversely, the overall network performance measures for each alternative/scenario were summarized in Table 20. The overall hourly throughput, maximum v/c ratio and the overall network average speed were included. The results show how the different CFI scenarios outperformed the CI scenarios in terms of the throughput, delay and average speeds except for the NS CFI alternative. Figure 56 illustrates the hourly throughput in each volume level for each alternative. Figures 57 and 58 demonstrate the relationship between the delay at each volume level and the corresponding v/c ratio for each alternative.



Table 20: Overall Network Performance Measures Comparison

Overall Network Performance	Volume Level	Input Volume (veh/hr)	Throughput (veh/hr)	Max V/C Ratio	Total Delay / Veh (sec)	LOS	Total Queuing (veh)	Avg Speed (mph)
Conventional Int	100%	6254	6301	1.00	49.1	D	66	17
	110%	6879	6942	1.02	64.2	E	124	14
	120%	7505	7351	1.12	111.5	F	770	10
	130%	8130	7399	1.21	145	F	2004	8
	140%	8756	7604	1.30	152.8	F	2471	8
Partial EW CFI	100%	6254	6316	0.86	44.2	D	42	17
	110%	6879	6869	0.87	51.7	D	59	16
	120%	7505	7401	0.95	91.2	F	948	12
	130%	8130	8015	1.02	130.7	F	1977	10
	140%	8756	8087	1.10	186.5	F	2509	8
Partial NS CFI	100%	6254	6520	0.93	56.7	E	209	16
	110%	6879	6867	0.99	127.8	F	1888	10
	120%	7505	7020	1.07	162.7	F	2116	9
	130%	8130	7155	1.13	212.5	F	2472	8
	140%	8756	7256	1.24	232.2	F	2596	7
Partial EN CFI	100%	6254	6570	0.74	52.9	D	64	21
	110%	6879	7110	0.81	60.1	E	552	21
	120%	7505	7667	0.89	76.3	E	1366	18
	130%	8130	8210	0.96	115.7	F	2318	14
	140%	8756	8337	1.03	160.1	F	2706	11
Full CFI	100%	6254	6485	0.66	49.5	D	189	23
	110%	6879	7085	0.73	54.8	D	190	22
	120%	7505	7749	0.80	59.8	E	320	21
	130%	8130	8613	0.86	70.6	E	858	19
	140%	8756	9096	0.93	104.2	F	2036	15

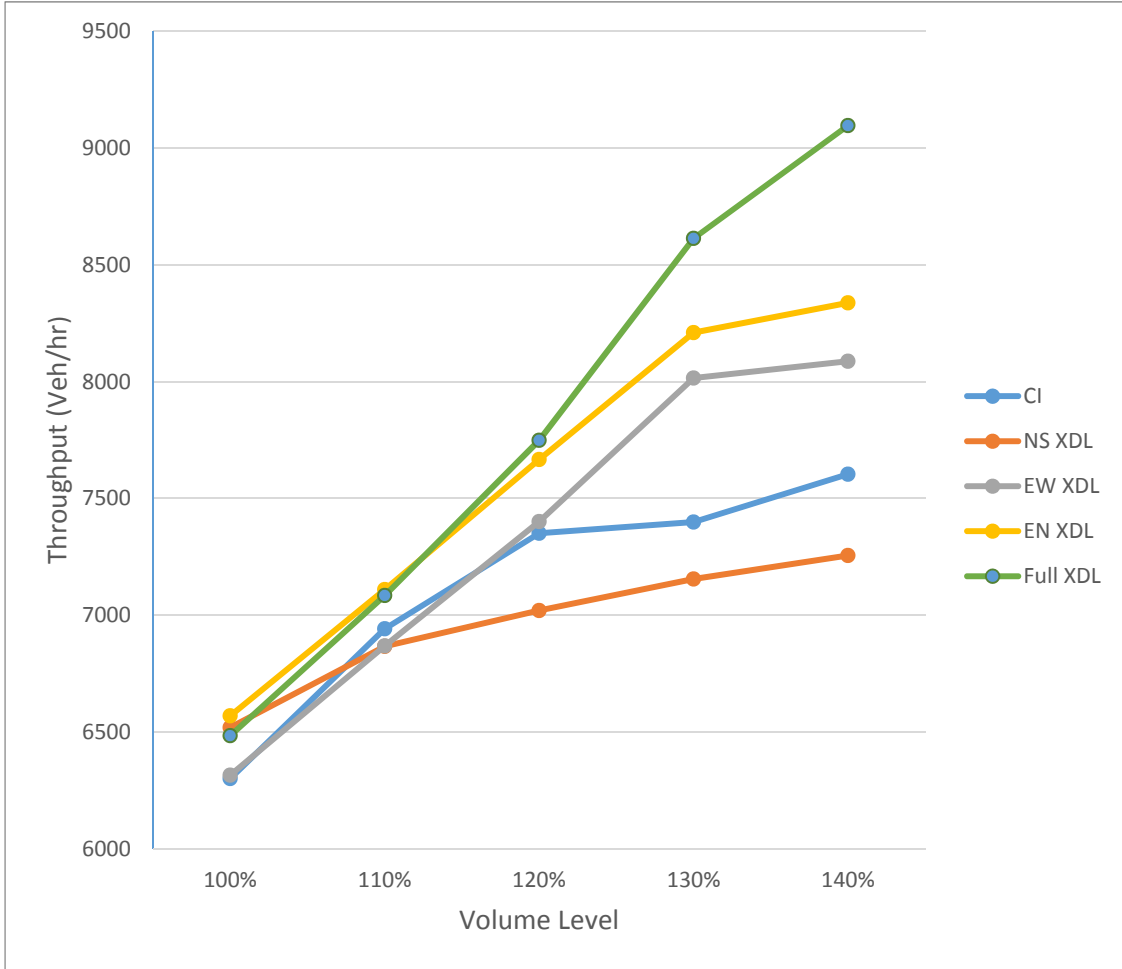

Figure 56: Volume Level versus Hourly Throughput by Intersection Type

As shown on Figure 56, the full, EW and EN CFI alternatives outperformed the NS CFI and the CI alternatives with respect to the throughput. Significant throughput improvements were remarkable at the higher volume level which is one of the main advantages of the CFI design through the reallocation of phase time savings to other heavy movements.

The v/c ratio is a measure of capacity sufficiency, that is, whether or not the physical geometry and signal design provide sufficient capacity for the subject movements. Delay is a measure of quality of service to the road user. Both must be analyzed to fully understand the anticipated operational characteristics of the intersection, and neither can be substituted for the other. However, it must be recognized that an intersection cannot operate beyond its capacity indefinitely without experiencing excessive delay which was revealed in the partial NS CFI and CI scenarios. Figures 57 and 58 explain this phenomenon where both intersections were operating near capacity in the existing conditions. As mentioned earlier, signal timing strongly affect the CFI operation along with the quality of progression, length of green phases, and cycle lengths especially when the volume exceeds the capacity. Thus, for any given v/c ratios greater than 1.00, a range of disproportionate delay values may result.

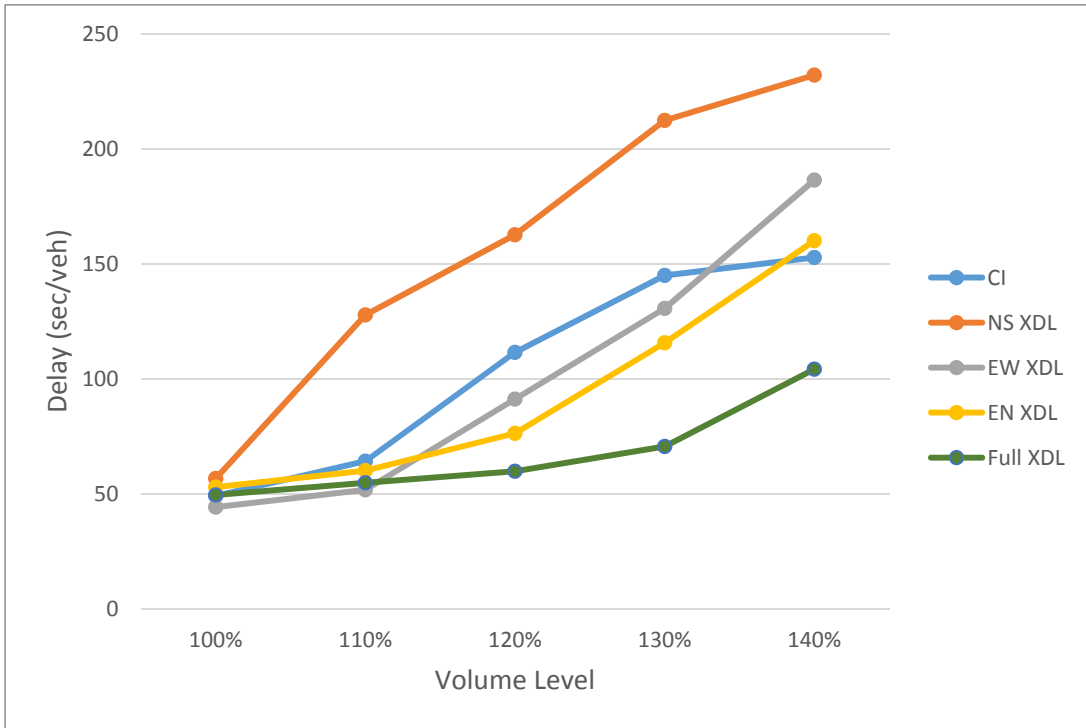

Figure 57: Volume Level versus Delay by Intersection Type

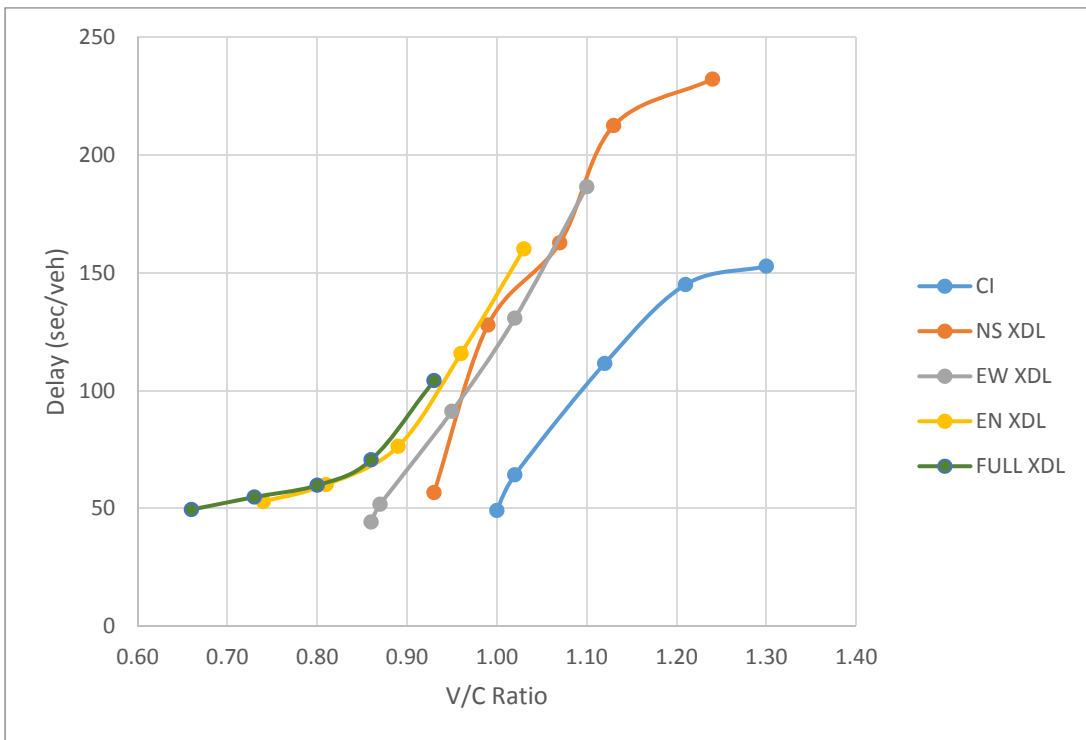

Figure 58: V/C Ratio versus Delay per Vehicle by Intersection Type



3.1.6.5 Discussion

From the above analysis, it was concluded that not any or all CFI designs can be a viable alternative. Similarly, partial CFI designs can be a comparable and cost effective alternative to the full CFI design. However, some factors need to be taken into account when considering a partial CFI alternative. Among these factors are the turning movement volumes. Although CFI configuration is typically considered to serve high left turn movements, other movements should also be considered especially the through movements. Based on the study intersection, partial NS CFI alternative did not compare favorably to the CI alternative. This was attributed to the fact that the east and west through volumes were considered high in addition to the heavy westbound left turn volumes. In these cases, a partial CFI on the north-south approaches did not provide a distinguishing advantage over a CI. Eliminating the heavy SBL turn and SBT high movements did not free up enough green time from the phase savings to serve the other heavy conflicting movements on the WBL, WBT and EBT approaches especially when they were operating at or above capacity. On the other hand, a partial EN CFI alternative proved to be effective and compared favorably to a full CFI alternative followed by the partial EW CFI alternative. In fact, the partial EW CFI alternative showed that CFI designs can be considered in situations with high through volumes and low left turn volumes and that the crossover lefts need not always be serving the direction of heavy left turns. Although these CFI designs do not achieve the maximum desirable capacity, they still provide enough overall capacity that would satisfy design year conditions as in the EN and EW CFI alternatives.

3.1.7 Benefit to Time Saving

In general, CFI had benefit-to-cost ratio when compared to the conventional intersection. However, the benefit of cost ratio depends on the type of CFI. For the study intersection, the benefit of time saving is shown in Table 19. The cost of delay was used \$17.67/hr as reported by Texas A&M Transportation Institute for year 2014.

Table 21: CFI Benefit to Time Saving Compared to the Conventional Intersection

Volume Level	Partial EW CFI	Partial NS CFI	Partial EN CFI	Full CFI
100%	\$329,406	-\$510,916	-\$255,458	-\$26,890
110%	\$924,301	-\$4,702,844	\$303,170	\$695,074
120%	\$1,637,664	-\$4,130,463	\$2,839,693	\$4,170,800
130%	\$1,249,697	-\$5,898,919	\$2,560,568	\$6,501,920
140%	-\$3,171,858	-\$7,473,162	-\$687,079	\$4,574,253



According to the Table 19, it was found that the partial EW CFI had the best benefits at the current volume level and 110% volume level. However, when the traffic volume was equal or more than 120%, the full CFI design would give the more benefits according to the time saving.

3.1.8 Conclusions

The analysis highlighted several important aspects regarding CFI traffic operations in the case of unbalanced volumes and demonstrated how partial CFI intersections can improve the overall intersection performance at various demands, reduce the costs associated with full CFI and proved to outperform the conventional intersection. However, partial CFI serving low volumes or only one of the critical movements while other critical movements are operating near or above capacity do not provide significant benefits when compared to the conventional intersection. Therefore it is crucial to consider critical movements in the partial CFI design. In the case of the partial NS CFI, eliminating the heavy SBL turn and SBT high movements did not free up enough green time from the phase savings to serve the other heavy conflicting movements on the WBL, WBT and EBT approaches particularly when they were operating above capacity. The analysis also showed that significant throughput improvements were remarkable at the higher volume level in the EN, EW and full CFI alternatives with percent increase in capacity of 25%. The percent reduction in delay for the critical movements in the CFI scenarios compared to the CI scenario ranged from 30-45%. Similarly, queue lengths showed percent reduction in the CFI scenarios ranging from 25-40%. It is crucial to note that arriving at an optimal signal timing strongly affect the CFI operation along with the quality of progression, length of green phases, and cycle lengths especially when the forecasted volumes exceed the capacity. The case study also provided fundamental points in the case of unbalanced volumes.

3.2 Median U-Turn (MUT)

3.2.1 Study Intersection and Roadway Conditions

The pilot study for the Median U-turn intersection was conducted for the intersection of US 27 and Hartwood Marsh Road located in Clermont, Florida. The intersection is 4-legged with Hartwood Marsh Road running east-west while US 27 running north-south. Hartwood Marsh Road is a 2-lane undivided arterial east of US 27 with posted speed limit of 40 mph, and it continues to 2-lane street Vista Del Lago Blvd with posted speed limit of 25 mph in west of US 27. Similarly, US 27 is a six lane divided principal arterial both south and north of Hartwood Marsh Road with posted speed limit of 55 mph. The east approach has one exclusive left-turn lane with storage length of about 550 feet, one through lane, and one exclusive right-turn lane with storage length of approximately 150 feet, whereas west approach consists of one exclusive left-turn lane with storage length of about 150 feet and one lane shared between through and right-turn movement. On the other hand, north-south approach consists of one exclusive left-turn lane, three through lanes and one exclusive right-turn lanes. The storage length of right-turn and left-turn lanes of the north-south approach ranges from 400 to 550 feet. This intersection was selected for the pilot study for couple of reasons. First, the intersection experience heavy traffic volumes on both mainline and Side Street resulting in heavy congestion in the peak hours. Second, the mainline has a wide median suitable for the Median U-turn and is operated with high speed. So, this investigation was performed seeking a possible alternative of the existing intersection in order to minimize the delay and congestion for better traffic operations. A snapshot of the study intersection is shown in Figure 59.



Figure 59: Study Intersection (US 27 and Hartwood March Road)

3.2.2 Right of Way

Median U-turn Intersections require wide medians in order to maneuver the U-turn movement at the median especially for large vehicles. Additionally, jug handles, loons and bulb-outs can be used to eliminate the need of wide medians. The wide median requires increased right of way while jug handles, loons and bulb could reduce the right of way. In this study intersection, the right of way was kept approximately same as the existing intersection with conventional design. The new design required some changes in the structure but the total width of the road was kept same as the conventional intersection. For example, exclusive left-turns does not exist in both direction of mainline but it requires an exclusive lane leading to U-turn crossover downstream of the intersection which kept the median width same as in the conventional intersection. Although the spacing from the main intersection to U-turn crossover varies in practice, the American Association of State Highway and Transportation Officials recommends spacing from 400 to 600 feet, while the Michigan Department of Transportation (MDOT) suggests 660 feet \pm 100 feet. For the study intersection, directional crossover was designed at approximately 600 feet in both north and south direction. This design also included the loon in order to maximize the radius of the U-turn movement which needed some extra area compared to the conventional design. In addition, the right-turn storage lanes were extended up to the location of loon to ease the flow. The east approach of Side Street also did not have exclusive left-turn lane, instead, it consisted of two exclusive right-turn lanes to incorporate the right-turn and left-turn traffics. The west approach remained same without the left-turn lane. Overall, the width of the road in all approach was approximately same as before. Figure 60 shows the MUT design coded in VISSIM at the study intersection location.



Figure 60: MUT Intersection Coded in VISSIM

3.2.3 Pedestrian and Bicyclist Interaction

Elimination of left-turn movement at main intersection in MUT intersection design significantly reduces the number of conflicts compared to the conventional intersection design as shown in the Figure 61. The decrease in conflict with pedestrians may lead to safer pedestrian crossing and better operation. However, the wide medians or refuge areas may increase the crossing distance as well as time. Generally, the main intersection is operated with a two-phase signal plan, one for mainline and the other for the side street through and right movements. The green time for side street provides green time for pedestrians crossing main street, and vice versa. There are mainly two types of pedestrian crossing in the main street: single-stage and two-stage. A single-stage pedestrian crossing requires longer green time in the side street so that pedestrian can cross the main street in one take. MUT design may reduce the waiting time for pedestrians in case of single-stage crossing with the decreased cycle length. Two-stage pedestrian crossing requires a refuge area in the median of the main road for pedestrians to complete the crossing in two-stages. Two-stage crossing needs a push button in the refuge area as well, and it may increase the pedestrian crossing time. Single-stage and two-stage pedestrian crossings are shown in Figure 62.

Conventional Intersection (32 conflict points)

MUT Intersection (16 conflict points)

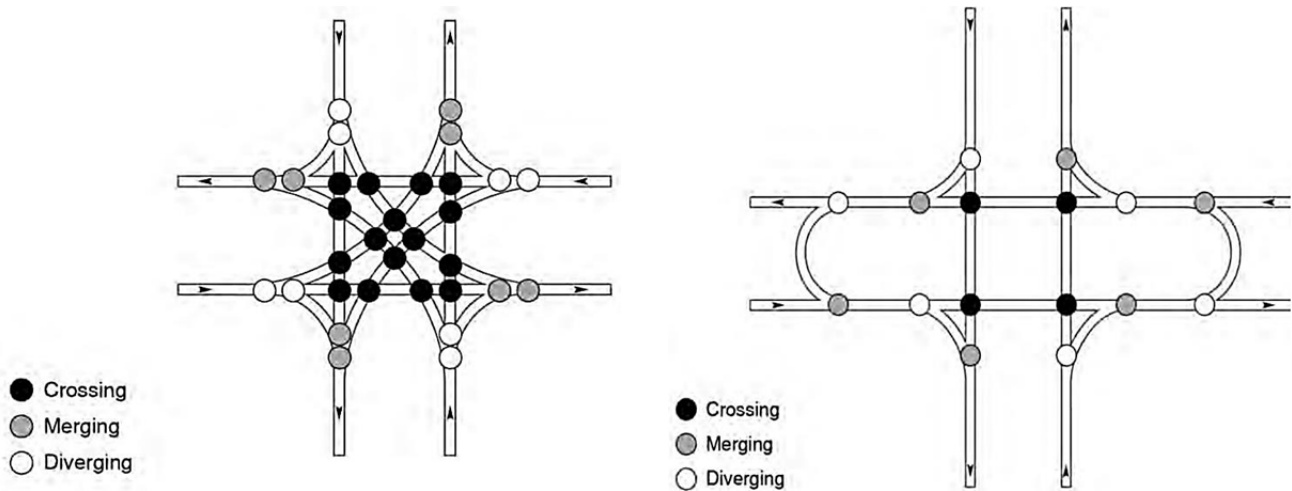

Figure 61: Conflict Points for Conventional and MUT Intersection

In this study intersection, two-stage crossing is recommended. Because the side street has comparatively low volume, less green time was provided, which was not enough for pedestrians to cross the main street in one stage. Even though two-stage crossing requires two cycles to cross the road, the reduced cycle length makes up a little bit for pedestrian crossing time decreasing the waiting time in each cycle. The proposed MUT intersection does not have any left-turn lanes, which reduces the number of lanes needed to be crossed compared to conventional intersection. Mid-block pedestrian crosswalk can be provided at the U-turn crossover since a fairly wide median is available.

In addition, the MUT crossing should also provide necessary arrangement for disable and visually impaired pedestrians. It should comply with policies and guidelines for the intersections provided by The Americans with Disabilities Act (ADA) and the Public Rights-of-Way. Pedestrian walkways must be delineated through landscaping, curbing, or fencing in order to accommodate vision-impaired pedestrians. Convenient slopes should be provided for wheelchair users and strollers. Curb ramps and detectable warning surfaces at the edge of sidewalks should be provided. Locator tones and audible speech messages need to be provided at pedestrian signals to assist blind pedestrians. Push buttons also need to be accessible by wheelchairs. The crosswalk widths should be wide enough to allow pedestrians and wheelchairs to cross without delays.

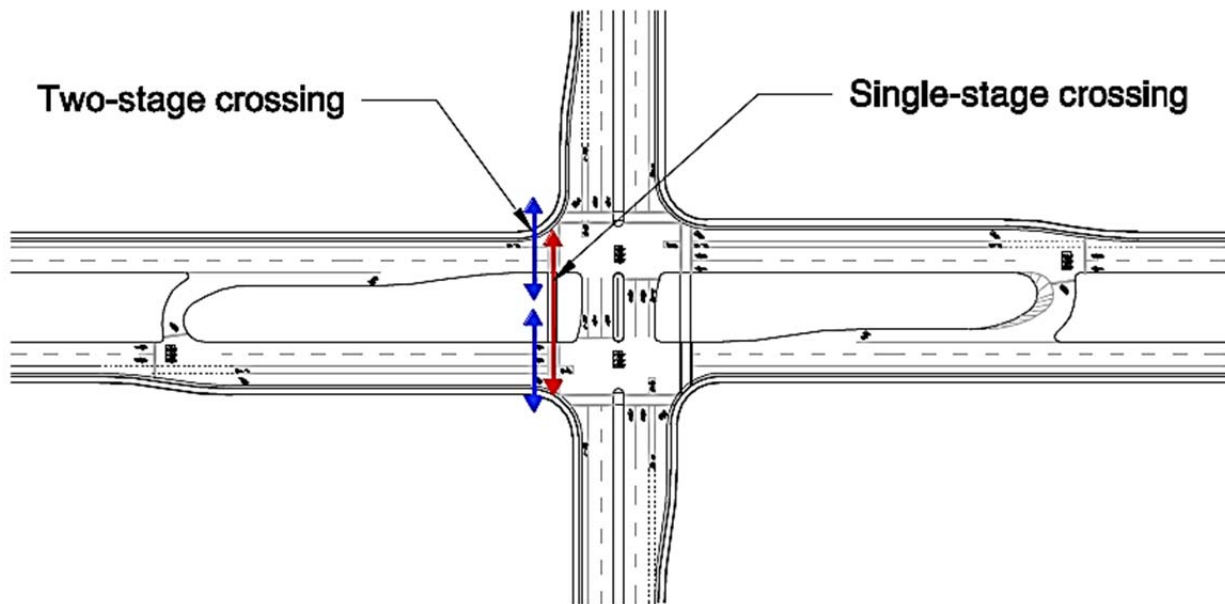

Figure 62: Single versus Two-Stage Pedestrian Crossing

Bicyclist going straight and turning right have more green time in MUT intersection due to the higher proportion of green time in each approach and smaller cycle length. The bicycle lane should be placed between right turn lane and through lanes for through movement in order to avoid conflict with right turning movement. Left-turning bicycles from the minor street can either use one of the following alternatives:

- Using the traffic lanes as passenger cars to make the turns. However, bicyclists using the same path as left-turning vehicles increase the distance to travel, and it may not be safer to move with high-speed vehicles.
- Using bicycle ramps on sidewalks or shared paths on the cross walks.
- Using bicycle turn queue boxes. When the bicyclists are approaching the intersection from the minor street they wait for the green light and proceed to the bicycle turn queue box. Once the major street gets the green light they can proceed along the major street. This is the most desirable approach. Figure 63 shows the left-turn options for bicycles as explained above.

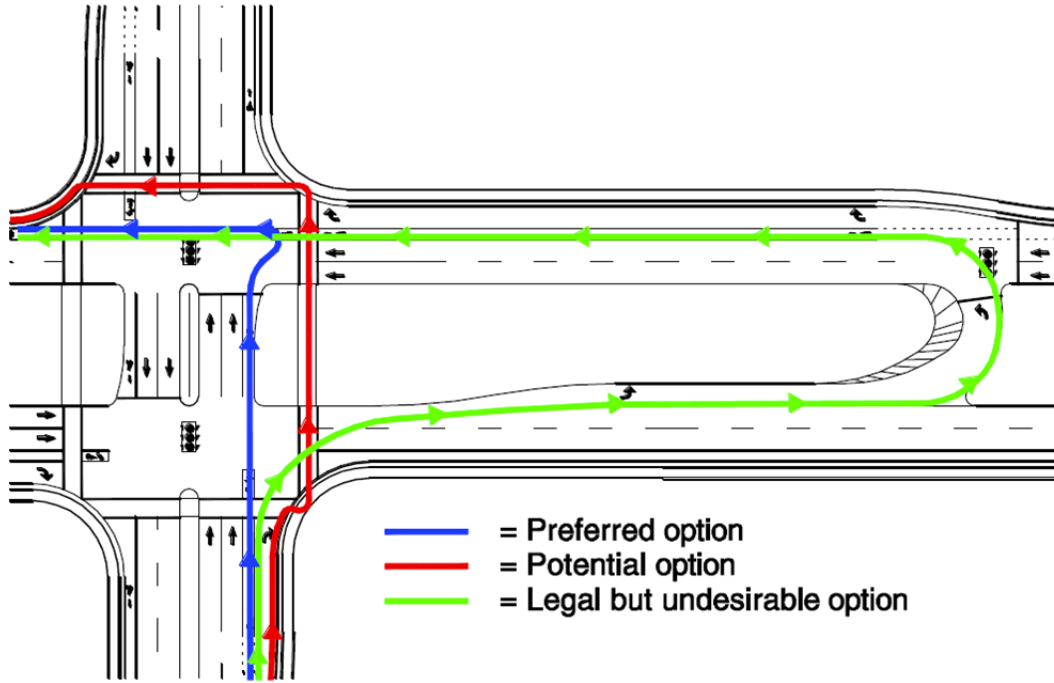

Figure 63: Left-Turn Options for Bicycles

3.2.4 Wayfinding

Wayfinding is very important at MUT intersection especially for the left-turning drivers who are not familiar with the intersection. The absence of left-turning movement at the main intersection may confuse the driver and tend to make mistakes causing collisions. Mainly signs and pavement markings are used to direct the left-turning vehicles in desired path. Left-turning vehicles at Minor Street are directed towards right side of the road and then left side of the major road towards the U-turn crossover. Similarly, left-turning vehicles at major road are directed towards U-turn crossover. These signs and pavement markings should be provided far before the intersection in order to guide the vehicles in right direction, and also at the intersections to prohibit some disallowed movements. “No Left Turns”, “One Way” and “Wrong Way” signs are most commonly used signs to prohibit the unauthorized left-turns at the intersections. Other several signs and pavement markings can be also used to direct the vehicles towards U-turn crossover.

Figure 64 provides an example of typical signing plan for the MUT intersection. Similar signing plan can be used for the intersection used in this pilot study with proper indication of name of the roads and measurements.

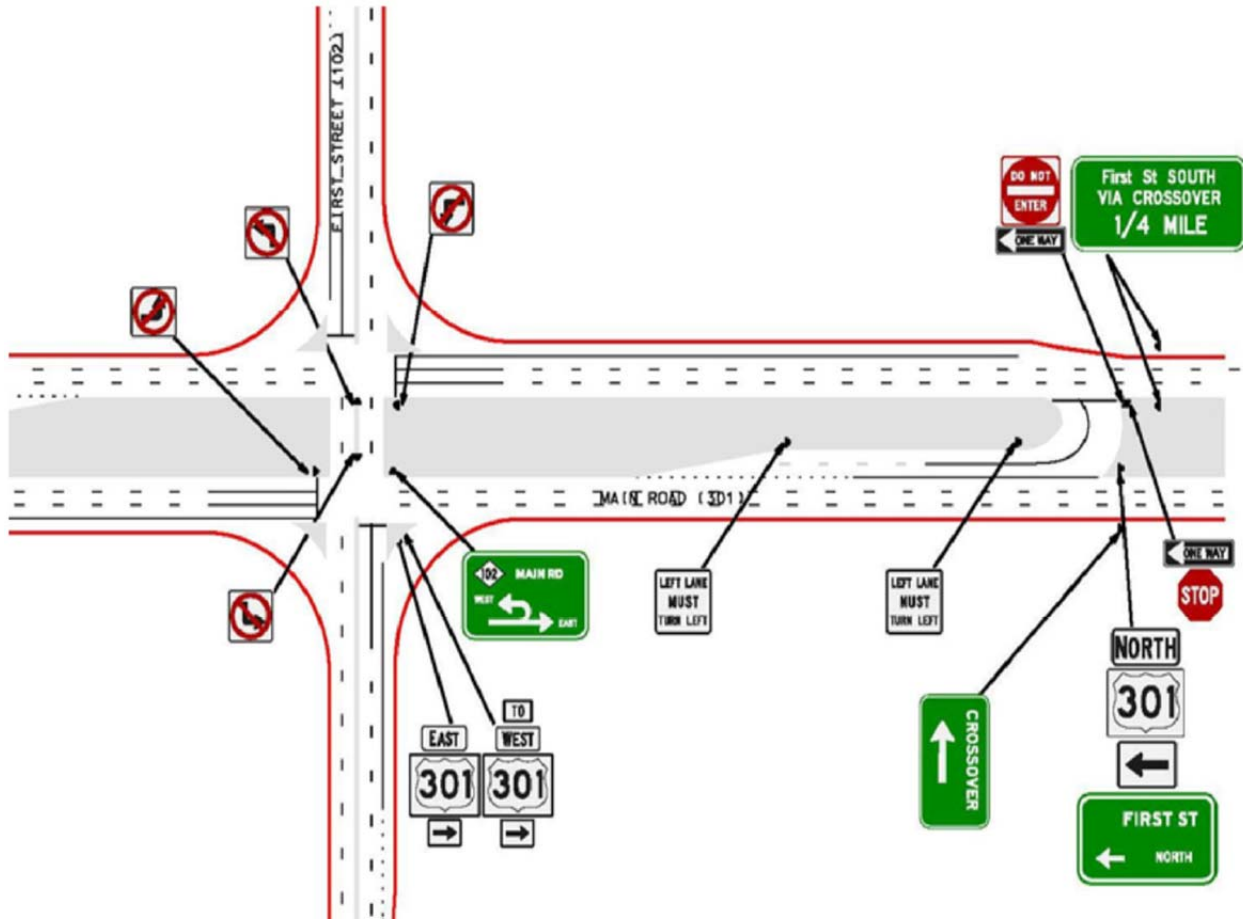

Figure 64: Example of Signing Plan for the MUT intersection

3.2.5 Signalization

In most of the cases, the U-turn crossover in the MUT design is signalized that operates the through and U-turn movement alternatively. U-turn crossovers are designed to move the left-turns from major and minor roads; usually volume from both left-turns adds up and warrants a traffic signal. However, an unsignalized or a stop-controlled crossover works fine in some cases especially at intersections with low left-turn traffic. Although MUT intersections may range from 3 to 5, most of the MUT designs have three signalized intersections. In addition to the main intersection, other two intersections at U-turn crossover needs to be signalized. It is recommended that signal heads must be placed no less than 40 ft and no more than 180 ft beyond the stop bar. It is common for a single controller to control all the signals in the system, but multiple controllers can also be utilized. Two phase signal are commonly utilized in this alternative. This results in shorter signal cycle length and more phases per hour for pedestrian and bicycles. These shorter cycle lengths allow for less time to be available for vehicles to store and form queues. There will be less "don't walk" time between "walk" times. It is recommended to prohibit the RTOR (Right Turn on Red) on the minor street to eliminate weaving conflicts on the major street. Intersections with high peak volumes may prohibit RTOR at these hours to

avoid weaving and conflicts. Left turn movements have more green time per cycle. Cycle lengths range from 60 to 120 seconds. Pedestrian crossing signals last about 33 seconds. Figure 65 shows the signal phasing plan typically employed at an MUT intersection with signalized crossovers. Basically, the major street receives green indications during one phase and the minor street and crossovers receive green indications during a second phase.

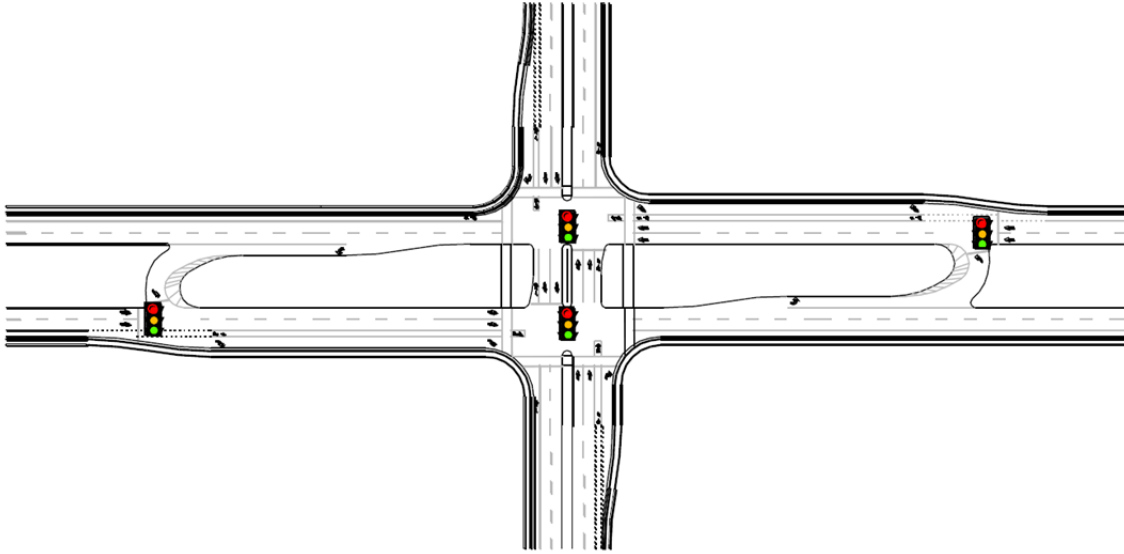

Figure 65: Typical MUT Intersection Signal Location

In the study intersection, three separate controller were used, one for each intersection. Each volume level needed different splits in order to maximize the overall network operational performance. The best signal timing plan for each volume level was chosen from multiple trial of different signal timing schemes using VISSIM simulation. Coordination of major street movement was also implemented.

3.2.6 Operational Performance

3.2.6.1 VISSIM Modeling

MUT intersection performance was evaluated based on VISSIM software version 6.0. VISSIM incorporated all the necessary traffic characteristics in order to replicate the existing scenario. The evaluation involved both existing conventional and MUT intersections. So, two separate VISSIM models were developed, one for conventional and other for MUT intersection. MUT intersection was developed using Median U-turn Informational Guide developed by FHWA in August, 2014.



Figure 66: VISSIM Model for Conventional and MUT Intersection

The model development process started with coding the network geometry of the existing intersection. Number of lanes in each movement, storage lengths, roadway width, lane sharing and usage and width of the median were the main structural measurements imported in the model. Traffic volume in each direction and in each movement was entered including the respective vehicle composition. Then, traffic signal heads were installed and the signal timing plan was imported in the model. Actual signal timing data was received from the County and used for the conventional intersection, while manually optimized signal timing plan was used for MUT intersection. Detectors were also placed right before stop bar in each approach. Lastly, appropriate priority rules were applied at the necessary conflicting areas. Snapshot of VISSIM model for Conventional and MUT intersection are shown in Figure 66.

In order to confirm that the model reflected the actual traffic characteristics and geometric condition, the model was calibrated and validated using the field data including traffic counts. Peak hour traffic counts were used in the validation that was extracted from video file for the study intersection recorded on March 24, 2015.

To evaluate the operational performance, the CI and MUT were set up in different volume levels and compared. Six volume levels were fixed that varied from 100% (existing volume) to 200% with 20% increment in each level. Therefore, a total of $6 \times 2 = 12$ experiments were performed and evaluated. Synchro was not best for the signal optimization, but it gave an estimate for the optimized cycle length and splits. Therefore, many trials for different signal timing plans were tested in VISSIM to figure out the best signal timings based on the overall network performance. Additionally, each experiment was simulated for 60 minutes. A total of three runs with different seeding values were completed for each scenario and the average of the 3 runs was reported for the analysis.



3.2.6.2 Results and Analysis

The comparison between the existing intersection with conventional design and alternative intersection with MUT design were performed based on the result from VISSIM output for each scenario. Table 22 represents the overall network performance for both intersections evaluated in terms of hourly throughput volume, delay per vehicle in sec, level of service, average speed in km/hr, and total travel time in sec.

Table 22: Overall Network Performance Measures for CI and MUT

Overall Network Performance	Volume Level	Input Volume	Throughput	Delay/veh (sec)	LOS	Average Speed (km/Hr)	Total Travel Time (sec)
Conventional Intersection	100%	3,183	3,100	34.29	C	39.07	224,064
	120%	3,820	3,718	38.66	D	36.79	285,015
	140%	4,456	4,332	46.62	D	33.25	368,453
	160%	5,093	4,868	69.26	E	26.05	529,787
	180%	5,730	5,132	121.71	F	17.12	855,723
	200%	6,366	5,271	139.47	F	15.31	977,035
MUT Intersection	100%	3,183	3,100	23.53	C	49.99	222,476
	120%	3,820	3,746	26.93	C	47.69	281,277
	140%	4,456	4,376	30.64	C	45.43	345,640
	160%	5,093	5,007	36.12	D	42.43	423,838
	180%	5,730	5,576	47.59	D	37.28	539,097
	200%	6,366	5,659	90.13	F	25.38	802,292

The throughput volume decreased significantly compared to input volume around 180% for conventional intersection and after 200% for MUT intersection, which is the indication of capacity of intersection. Comparison of hourly throughput volume for each volume level between CI and MUT intersection is illustrated in the Figure 67. The change in hourly throughput volume was seen after volume level of 140%, it increased in case of MUT compared to CI ranging from about 3% to 8%. Trend of delay per vehicle for each volume level was also plotted to compare between MUT and CI as shown in Figure 68. The difference in overall delay could be seen in each volume level but it was maximum at 180% volume level at which CI



reached its capacity. The overall travel time also followed the same pattern as delay and showed improvement for MUT up to 37%. Level of service was also improved in each volume level except 100% and 200% level. Based on the results, it can be concluded that MUT intersection significantly improved the overall operation and capacity over CI.

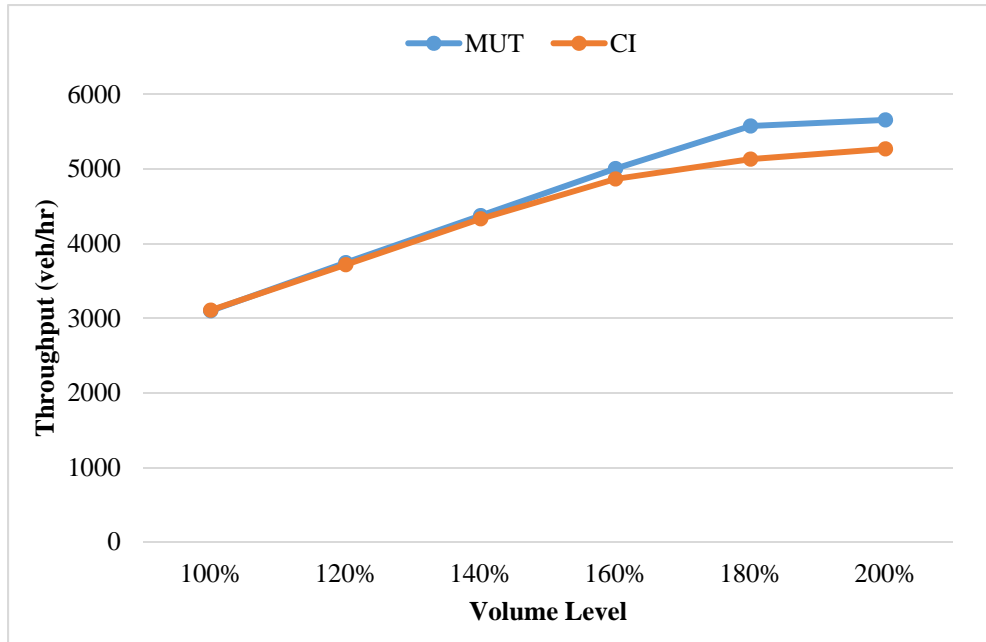

Figure 67: Volume Level versus Hourly Throughput between CI and MUT Intersection

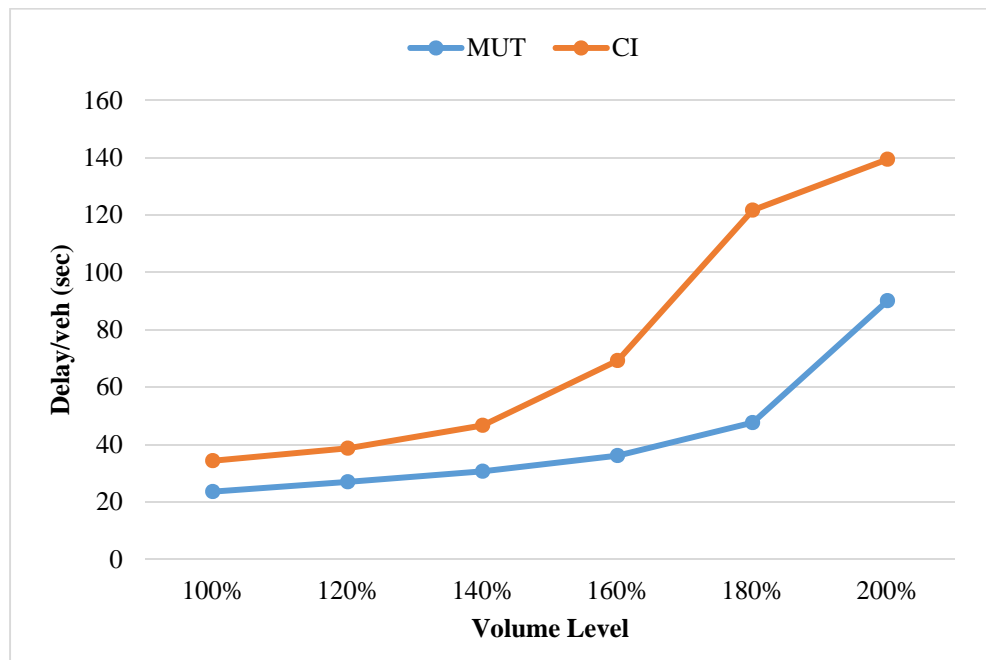

Figure 68: Volume Level versus Delay per Vehicle between CI and MUT



Table 23: Performance Measures Comparison by Movement — Volume Level 100%

Movement	Volume	Delay/veh (sec)		LOS		Travel Time (sec)	
		CI	MUT	CI	MUT	CI	MUT
WBL	352	46.25	39.47	D	D	73.62	93.29
WBT	56	48.06	19.59	D	B	73.05	45.02
WBR	393	3.48	5.19	A	A	32.53	34.62
SBL	337	60.92	44.82	E	D	76.4	81.9
SBT	801	22.29	17.44	C	B	39.77	35.1
SBR	58	0.78	9.23	A	A	14.89	23.53
EBL	67	38.67	37.8	D	D	77.04	110.11
EBT	55	69.34	24.48	E	C	97.61	53.77
EBR	6	61.71	4.41	E	A	92.86	28.06
NBL	18	83.78	38.96	F	D	98.47	72.4
NBT	785	47.76	15.44	D	B	67.24	34.91
NBR	255	5.98	10.15	A	B	20.33	27.67

Table 24: Performance Measures Comparison by Movement – Volume Level 200%

Movement	Volume	Delay/veh (sec)		LOS		Travel Time (sec)	
		CI	MUT	CI	MUT	CI	MUT
WBL	704	97.81	147.85	F	F	125.14	201.64
WBT	112	88.64	22.57	F	C	113.62	48.01
WBR	786	23.5	86.34	C	F	52.64	115.73
SBL	674	170.46	84.46	F	F	185.99	121.55
SBT	1602	48.35	41.12	D	D	65.97	58.76
SBR	116	6.36	13.97	A	B	20.48	28.33
EBL	134	57.15	69.52	E	E	95.7	141.89
EBT	110	77.92	21.34	E	C	106.75	50.85
EBR	12	58.58	26.54	E	C	88.82	50.17
NBL	36	101.76	61.79	F	E	116.58	95.54
NBT	1570	126.97	31.04	F	D	146.53	50.5
NBR	510	33.79	18.69	C	B	48.19	36.17



The comparison of operational performance between CI and MUT was performed for each approach as well. Head to head comparison by movement in terms of delay per vehicle, level of service and travel time is presented in Table 23 for 100% volume level and Table 24 for 200% volume level. For 100% volume level, almost every approach for MUT performed better than CI. Even the left-turn movement which has to use the U-turn crossover had the better delay and LOS as shown in Table 23. For example, delay was changed from 47.76 sec to 15.44 sec for NBT approach, and level of service improved from D to B. Similarly, other indirect left-turns also performed better in terms of delay and LOS. However, the travel time for WBL and EBL increased for MUT compared to CI because of the longer distance needed to travel. NBL and SBL still had the better travel time for MUT. For 200% volume level, some left-turn and right-turn for MUT were affected in terms of delay and level of service. But, the major movements NBT and SBT performed very well under MUT design as demonstrated in Table 24. Some movements such as WBL, EBL and WBR were affected in MUT design for 200% volume level. Overall, most of the movements performed better for MUT design compared to CI. Some major approaches such as NBT, SBT, and SBL represented large part of the network, improvement on these approaches hugely contributed for better overall network performance.

3.2.7 Benefit to Time Saving

Generally, MUT had moderate benefit-to-cost ratio when compared to the conventional intersection. The cost of converting a conventional intersection to an MUT intersection varies depending on the specific project context. The cost of MUT intersection depends on the aspects such as the number and length of additional lanes required, utility impacts, modifications to the existing signal system, amount of additional right of way, and access modifications. The right of way cost may change by geographical location.

For the study intersection, delay savings by MUT intersection compared to conventional intersection was calculated. Table 25 shows the benefit of MUT over CI in terms of delay savings in one year. The cost of delay was used \$17.67/hr as reported by Texas A&M Transportation Institute for year 2014.

Table 25: Reduction of Cost by MUT by Saving Delay

Volume Level	Total Vehicle Time Reduction (vehicle-hour/day)	One-year Cost Reduction (dollar)
100%	56.47	\$364,235
120%	72.57	\$468,034
140%	116.42	\$750,838
160%	271.62	\$1,751,842
180%	499.30	\$3,220,255
200%	413.74	\$2,668,443



3.2.8 Conclusion

This study underlined the important aspects of MUT intersection operation and showed the improvement in operational performance in case of MUT compared to the existing condition. MUT design significantly reduces the number of conflicts at the main intersection, which offers a better operation and safety for motor vehicles, pedestrians, and bicyclists. The two-phase signal timing plan provides higher percentage of green time for through movements that ensures a better through operation. However, the left-turn movements may experience higher delay and travel time due to their indirect left-turn movement through U-turn crossover. Pedestrians and bicyclists also get higher percentage of green time but they may have to cross the major street in two-stage potentially increasing the waiting time. Wayfinding is very important at MUT intersection especially for left-turning drivers who are not familiar with the intersection. Moreover, the case study at a specific intersection demonstrated that MUT intersection reduced the overall delay and travel time, and improved the level of service compared to conventional intersection. The MUT design outperformed the conventional intersection in terms of delay and travel time for increased volume scenario as well. Overall, MUT intersection performs better compared to conventional intersection.

3.3 Restricted Crossing U-Turn Intersection

3.3.1 Study Intersection and Roadway Conditions

The pilot study for the Restricted Crossing U-turn intersection was conducted for the intersection of US 27 and Hartwood Marsh Road located in Clermont, Florida. The intersection is 4-legged with Hartwood Marsh Road running east-west while US 27 running north-south. Hartwood Marsh Road is a 2-lane undivided arterial east of US 27 with posted speed limit of 40 mph, and it continues to 2-lane street Vista Del Lago Blvd with posted speed limit of 25 mph in west of US 27. Similarly, US 27 is a six lane divided principal arterial both south and north of Hartwood Marsh Road with posted speed limit of 55 mph. The east approach has one exclusive left-turn lane with storage length of about 550 feet, one through lane, and one exclusive right-turn lane with storage length of approximately 150 feet, whereas west approach consists of one exclusive left-turn lane with storage length of about 150 feet and one lane shared between through and right-turn movement. On the other hand, north-south approach consists of one exclusive left-turn lane, three through lanes and one exclusive right-turn lanes. The storage length of right-turn and left-turn lanes of the north-south approach ranges from 400 to 550 feet. This intersection was selected for the pilot study for couple of reasons. First, the intersection has heavy traffics in both mainline and side street resulting congestion in the peak hours. Second, the mainline has a wide median suitable for the Median U-turn and is operated with high speed. So, this investigation was performed seeking a possible alternative of the existing intersection in order to minimize the delay and congestion for the better traffic operation. The snapshot of study intersection is shown in Figure 69.



Figure 69: Study Intersection (US 27 and Hartwood March Road)

3.3.2 Right of Way

Restricted Crossing U-turn Intersections require a wide median and bulb-outs in order to accommodate the U-turn movement at the median especially for large vehicles. Loons and bulb-outs are used to substitute the wide medians. RCUT intersections can have three or four legs; in four legged intersections there are two U-turn crossovers and left/through minor street restrictions. Unsignalized RCUTs may have channelized islands to allow farm equipment to make Minor Street through movements with ease. In order to prevent weaving in merge controlled intersections, the U-turn crossovers should be up to half a mile apart from the main intersection. Curbed islands, delineation, and traffic control devices can help prohibit vehicles from the minor street to make left turns on the main intersection. Consecutive RCUT U-turn crossovers need to have a minimum separation of 100 feet. The recommended and desired separation is 150 feet. In order to accommodate trucks, crossovers should have multiple lanes to accommodate the required turning path. The typical crossover width for one lane is 30 feet. Stop sign and merge RCUT crossovers usually have one lane only, but crossovers can hold up to two lanes. Major streets in the RCUT intersection can have four to eight lanes, while minor streets can have up to four through lanes. The right of way for the major street should be at least 70 feet. This would include a 10 foot median, four 10 foot travel lanes, a 10 foot left turn crossover, and a 10 foot buffer. The recommended right of way for major streets ranges from 137 feet for four lane roads and 161 feet for eight lane roads. Lanes are typically 12 feet wide. Minor street medians on this alternative should be at least 6 feet wide. Minor streets may have the option of having a channelizing island that separates all right turn lanes from the minor street lanes leaving the intersection, a channelizing island that separates minor street right turns remaining on the major street and minor street right turns using the U-turn, or having no channelization. The RCUT is the only existing at-grade design that permits each direction on a two-way arterial to function independently.



Figure 70: RCUT Intersection Coded in VISSIM



For the study intersection, the right of way was kept approximately same as the existing intersection with conventional design. However, some extra right of way was required for the loon designed at the U-turn crossover. The new RCUT design required some changes in the structure but the total width of the road was kept approximately same as the conventional intersection. The additional left-turn lane heading to the U-turn crossover was added in the median area in the existing location. The directional crossover was about 600 feet in both north and south direction and was located approximately 100 feet from the main intersection. This design included the loon in order to maximize the radius of the U-turn movement which needed some extra area compared to the conventional design. In addition, the right-turn storage lanes were extended up to the location of loon to ease the flow. Figure 70 shows the RCUT intersection coded in VISSIM at the study intersection location.

3.3.3 Pedestrian and Bicycle Interaction

RCUT intersection eliminates the through and left-turn movements from the minor street at the main intersection and reduces the number of conflicts with pedestrian. It reduces the number of vehicle-pedestrian conflict points from 24 to 8 using a “Z” crossing as shown in the Figure 71. On the major road the pedestrian crossings are set up as a diagonal path that goes from one corner to the opposite corner. Figure 72 shows the path of “Z” crossing. Another crossing alternative is done by having the minor street be offset in order to allow for a perpendicular pedestrian crossing on the major street to be available. This crossing decreases pedestrian exposure to vehicles, but cannot be built on existing streets. This crossing alternative is recommended at locations where the minor streets or driveways have not been built. The “Z” crossing is the recommended crossing approach. Pedestrian crosswalks on the RCUT may be longer for pedestrians to cross when compared to the conventional intersection. By adding a raised barrier or channelization between the major street through lanes and the right turn lanes, the crossing distance could be reduced. Channelization like curbs, railings, and landscaping can direct and assist pedestrians when crossing the streets. RCUT’s short cycle lengths can help accommodate pedestrians, but less signalized movements and wide footprints may make it difficult to accommodate pedestrians in many situations. This alternative also allows the possibility of having mid-block crosswalks at the U-turn crossovers. Three legged RCUT intersections require at least one mid-block crosswalk; two mid-blocks can reduce the amount of out-of-direction travel for pedestrians. They also accommodate pedestrians and bicycles through channelization that serve as an effective refuge island. Prohibiting right turns on red (RTOR) will diminish conflicts for pedestrians. Pedestrian crossings can be done in one or two-stages, pedestrians can use the median if crossing in two-stages. Two-stage crossings are mostly used in RCUT alternatives. The time allocated for pedestrian “walk” time is the same as the minor street green time. The “Z” crossing is not a usual pedestrian crossing treatment, so it may be confusing for some pedestrians. Appropriate signs must be used to direct the pedestrians across the roadway. Although crossing distances and conflicts may slightly increase, most RCUT pedestrian-vehicle conflicts are protected.

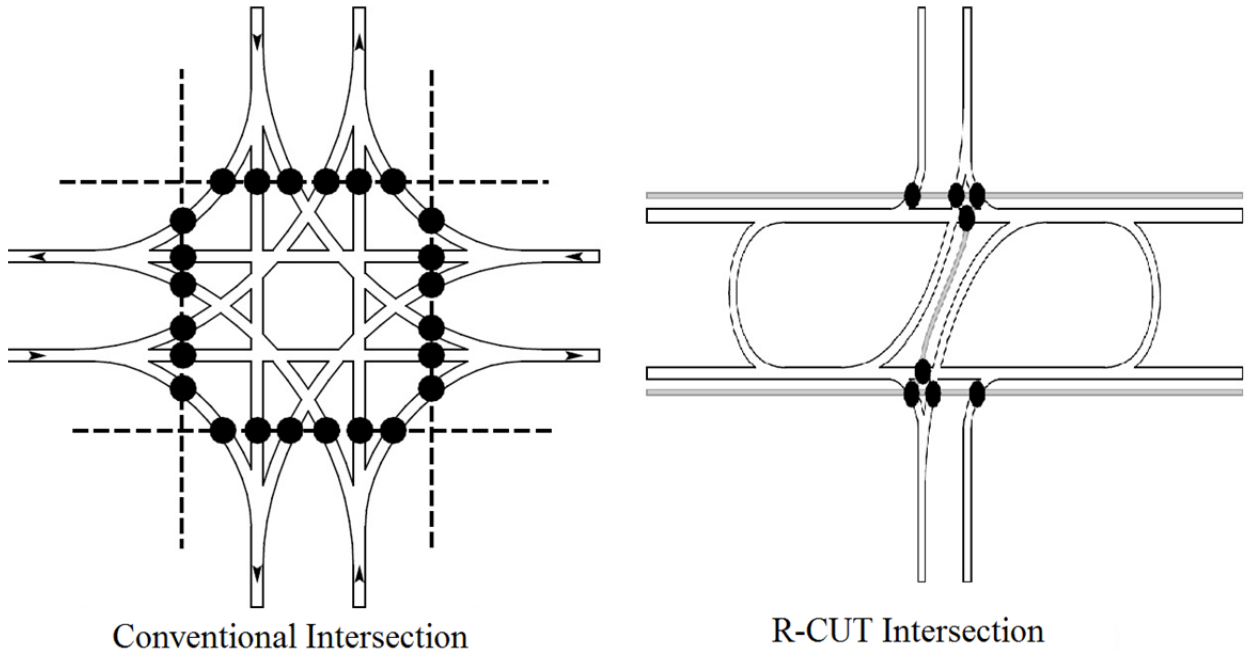

Figure 71: Vehicle-Pedestrian Conflict Points at a RCUT Intersection

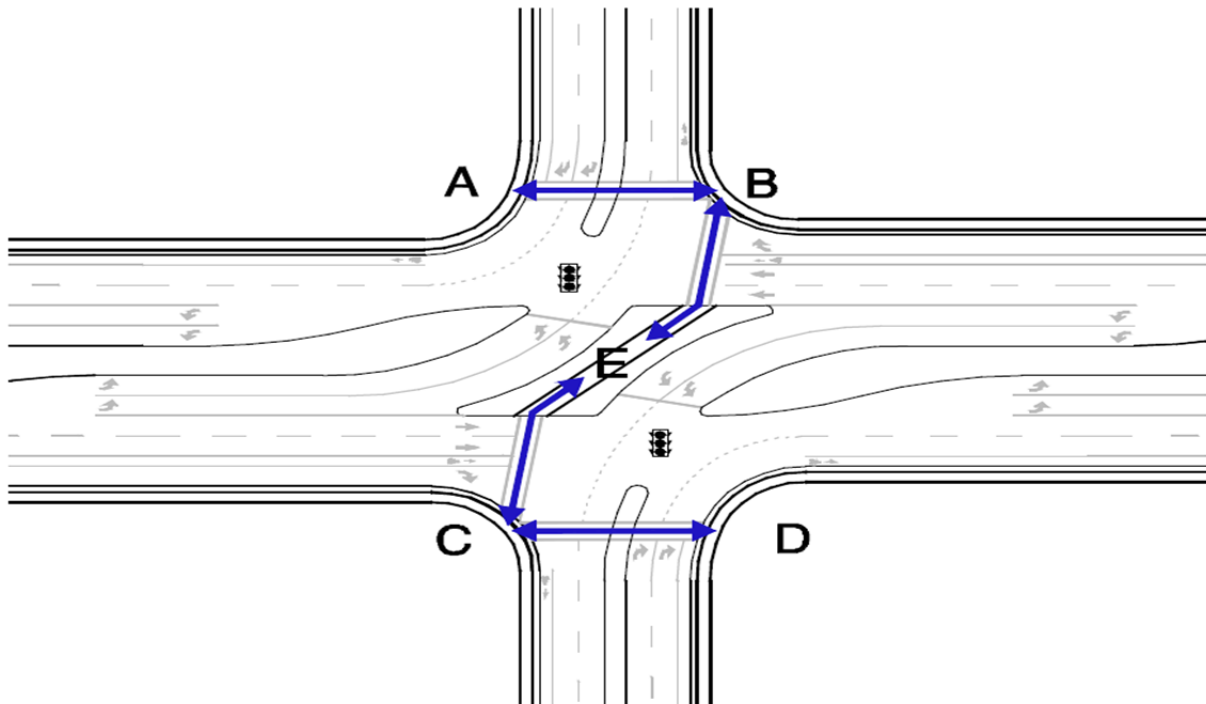

Figure 72: Pedestrian Crossing at a RCUT Intersection

Accessibility to pedestrians with disabilities and vision and/or mobility impairments should be accounted for in the RCUT. The Americans with Disabilities Act (ADA) and the Public



Rights-of-Way present policies and guidelines which need to be accounted for to have an intersection that will accommodate all pedestrians. Pedestrian walkways must be delineated through landscaping, curbing, or fencing in order to accommodate blind pedestrians. Slopes should be provided for wheelchair users and strollers. Curb ramps and detectable warning surfaces at the edge of sidewalks should be provided. Locator tones and audible speech messages need to be provided at pedestrian signals to assist vision-impaired pedestrians. Push buttons need to be accessible by wheelchairs. The crosswalk widths should be wide enough to allow pedestrians and wheelchairs to cross without delays. Unsignalized RCUT intersections do not experience much pedestrian interaction, treatments like the pedestrian hybrid beacons (PHB) and the rectangular rapid flash beacons can be used. The “Z” crossing may be challenging for vision impaired pedestrians, special instructions must be implemented to help to direct them across. Potential mitigations are to implement an audio cue for crossing or construct a pedestrian bridge for the major street crossing.

Bicycles travel the major road the same way on the RCUT as the conventional intersection. The through and right turning bicycles at RCUTs are provided with more green time percentages, which usually results in lower delays and fewer stops. Bicycle lanes are usually separated from the general vehicle lanes by implementing buffered bike lanes or cycle tracks. The left turning bicyclist can ride in the left turn lane or stop at the crosswalk to use the “Z” crossing. Right turn lanes can be shifted to the right of bicycle lanes to reduce conflicts and vehicle-bicycle exposure. There are three ways to serve the through and left turn bicyclist on the minor streets. They may use the “Z” crossing like pedestrians do, they may use the U-turn crossover like vehicles, or they may pass through/across a channelizing islands. The direct bicycle crossing would only be utilized at a rural area were the “Z” crossing is not available. Specific signs will need to direct bicyclist to the pathway through movement on the median for direct bicycle crossings. The “Z” crossing is the best approach for bicyclist crossing the major street. Figure 73 shows the minor street through option for bicycles as explained above.

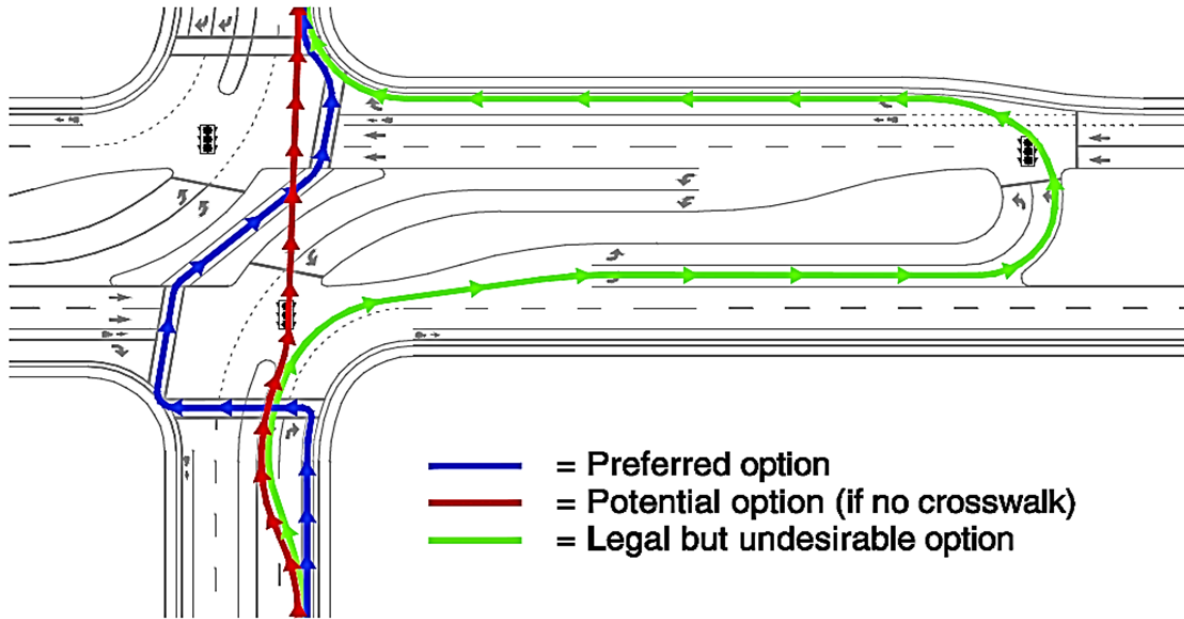

Figure 73: Minor Street Through Option for Bicycles

3.3.4 Wayfinding

Wayfinding is not as vital in this alternative when compared to the other alternative intersections. Special pedestrian signs will be needed in the minor street offset design to prevent pedestrians from crossing at the minor street intersections and guide them to the crossing locations. Less signs will be required since crossovers are directional and channelization will prevent vehicles from performing prohibited turns. Although this is the case, signs and markings will still be required to direct the vehicles through the U-turn crossover and prevent wrong way movements. Signs prohibiting parking on loons will be required to prohibit any obstructions. Signs and pavement markings prohibiting through and left turns on the minor street should be utilized. “One way” and “wrong way” signs should be used to assist the U-turn channelization. Suitable lighting should be provided on the RCUT’s conflict points and crosswalks. If right turns on red (RTOR) are restricted, signs will need to be provided to advise the vehicles on the minor street. Overhead lane signs can help guide the vehicles into the proper lanes, these signs should be about 350 feet prior to the stop bars. Extension pavement markings (Dotted) can help guide the turning vehicles. Stop or yield signs will be needed for stop-controlled and merge controlled crossovers. Merge controlled crossovers may also use flashing yellow beacons. Common pavement markings include right turn arrows, left turn arrows, left and through turn arrows, stop bars, and “Only” markings.

A similar signing plan as shown in Figure 74 with proper name of the roads and actual measurements is recommended for the study intersection.

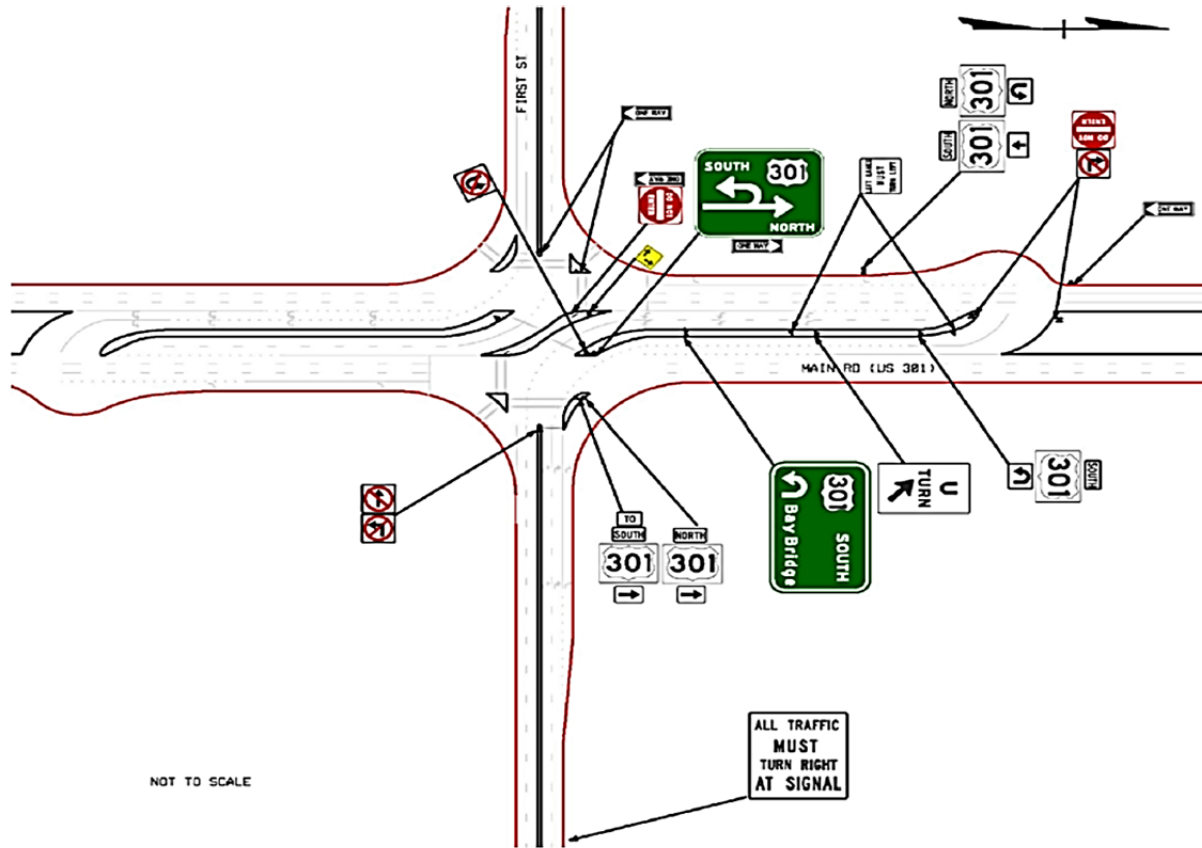

Figure 74: Typical Signing for RCUT Intersection

3.3.5 Signalization

RCUTs can be signalized, stop-controlled, or merge controlled. The signalized intersections can be commonly seen in urban and suburban corridors. Stop-controlled RCUTs can be seen at rural areas on four lane divided arterials. Merge controlled RCUTs are used at rural areas for high speed divided four lane corridors, they function as freeways. Signalized RCUTS serve various modal users and unsignalized RCUTs serve a variety of users including farm equipment at rural areas. Signalized crossovers with aligned side streets may have a third phase to avoid conflicts. This alternative minimizes the phases and only two phases are needed to accommodate the vehicles and pedestrians. One phase is for the main street and the other is for the crossover or Minor Street. One to six traffic signals will be needed to control a four legged RCUT intersection. The RCUT offers traffic signal placement flexibility. The arterials' through movement receive two-thirds (2/3) to three-fourths (3/4) of the green time allocated for the cycle. Cycle lengths are shorter at RCUTs than at conventional intersections which can reduce the amount of lost time per cycle. Typical cycle lengths range from 40 to 60 seconds for the main line and 25 to 40 seconds for the U-turns.

The major street should have a high percentage of green time. Locations that have side streets aligned with crossovers can have the same signal phase if there is low volume and sufficient



space available. RCUTs may be provided with bi-directional progression and signal timings at this alternative can use common cycle lengths or different cycles for the major street directions. Using a common cycle may cause delay in one of the directions, sometimes it is recommended to phase the directions individually. The intersection may be controlled by one controller or various controllers. Figure 75 showed a typical signal location at RCUT intersection.

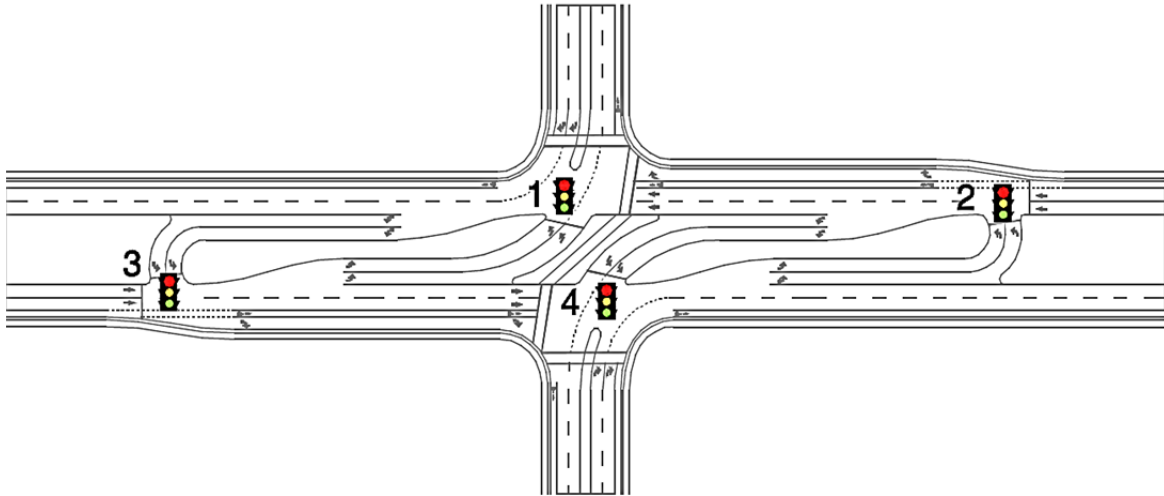

Figure 75: Signal Location at RCUT Intersection

In the study intersection, three separate controllers, one for each intersection, were used. The through movement in the main street was coordinated. Each volume level needed different splits in order to maximize the overall network operational performance. The best signal timing plan for each volume level was chosen from multiple trial of different signal timing schemes using VISSIM simulation.

3.3.6 Operational Performance

3.3.6.1 VISSIM Modeling

RCUT intersection performance was evaluated using the microsimulation software, VISSIM version 6.0. VISSIM was able to incorporate all the necessary traffic characteristics and structures in order to replicate the actual scenario. The evaluation involved both existing conventional and RCUT intersection. So, two separate VISSIM models were developed, one for conventional and other for RCUT intersection. RCUT intersection was developed using Restricted Crossing U-turn Informational Guide developed by FHWA in August, 2014.

The model development process started with drawing structure of the network. The geometry of the existing intersection as seen in the Google Map was constructed in the model. Number of lanes in each movement, storage lengths, roadway width, lane sharing and usage and width of the median were the main structural measurements imported in the model. Total volumes in each direction and in each movement were entered including the respective vehicle composition. Traffic signal heads were installed and the signal timing plan was imported in the model. Actual

signal timing data was received from the County and used for the conventional intersection, while manually optimized signal timing plan was used for RCUT intersection. Detectors were also placed right before stop bar in each approach. Lastly, appropriate priority rules were applied at the necessary conflicting areas. Snapshot of VISSIM model for Conventional and RCUT intersection are shown in Figure 76.



Figure 76: VISSIM Model for Conventional and RCUT Intersection

In order to confirm that the model reflected the actual traffic and geometric condition, the model was calibrated and validated using the field data including traffic counts. Peak hour traffic counts were used in the validation that was extracted from video file of the study intersection recorded on March 24, 2015.

To evaluate the operational performance, the CI and RCUT were set up in different volume levels and compared. six volume levels were fixed that varied from 100% (existing volume) to 200% with 20% increment in each level. Therefore, a total of $6 \times 2 = 12$ experiments were performed and evaluated. Synchro did not give best optimized signal plan, but it gave an estimate for the optimized cycle length and splits. Therefore, many trials for different signal timing plans were tested in VISSIM to figure out the best signal timings based on the overall network performance. Additionally, each experiment was simulated for 60 minutes. A total of three runs with different seeding values were completed for each scenario and the average of the three runs was used for analysis.

3.3.6.2 Results and Analysis

Operational performance of RCUT intersection was evaluated by comparing with conventional intersection. The VISSIM output were produced in each volume level for both conventional and RCUT intersection and compared some measure of performances such as hourly throughput volume, delay per vehicle in sec, level of service, average speed in km/hr, and total travel time. Table 26 demonstrates the complete results of overall network performance for CI and RCUT intersection.



Table 26: Overall Network Performance Comparison between CI and RCUT Intersection

Overall Network Performance	Volume Level	Input Volume	Throughput	Delay/veh (sec)	LOS	Average Speed (km/hr)	Total Travel Time (sec)
Conventional Intersection (CI)	100%	3,183	3,108	34.29	C	39.07	224,064
	120%	3,820	3,718	38.66	D	36.79	285,015
	140%	4,456	4,332	46.62	D	33.25	368,453
	160%	5,093	4,868	69.26	E	26.05	529,787
	180%	5,730	5,132	121.71	F	17.12	855,723
	200%	6,366	5,271	139.47	F	15.31	977,035
RCUT Intersection	100%	3,183	3,103	19.09	B	52.25	206,142
	120%	3,820	3,753	21.58	C	50.36	258,195
	140%	4,456	4,387	25.15	C	47.83	318,049
	160%	5,093	4,984	30.97	C	44.26	391,065
	180%	5,730	5,312	46.94	D	37.20	505,888
	200%	6,366	5,517	64.61	E	30.60	635,138

The throughput volume was observed significantly smaller than the input volume around 180% for conventional intersection and around 200% for RCUT intersection, which is the indication of capacity of the intersection. Figure 77 demonstrates the hourly throughput volume for CI and RCUT for each volume levels. The throughput volume increased for RCUT compared to CI, although the change was not very large (up to 5%). Figure 78 showed the relationship between delay per vehicle and volume level for CI and RCUT. The difference in overall delay was observed in each volume level but the highest was observed at 180% volume level as shown in Figure 78. As mentioned earlier, the capacity was reached for CI at around 180% volume level that produced the maximum difference in delay between CI and RCUT intersection. The overall travel time also followed the same pattern as delay and showed improvement for RCUT up to 40%. Level of service and average speed was also improved in each volume level. RCUT design outperformed CI in each measure of performance for overall network.

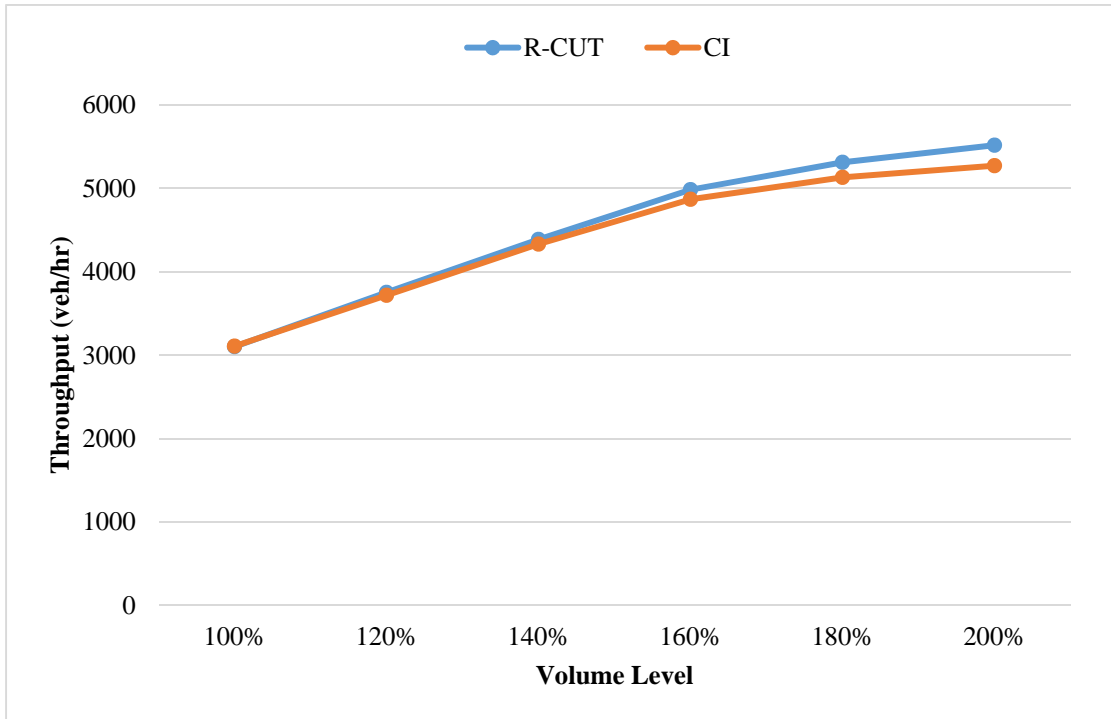

Figure 77: Volume Level versus Hourly Throughput between CI and RCUT Intersection

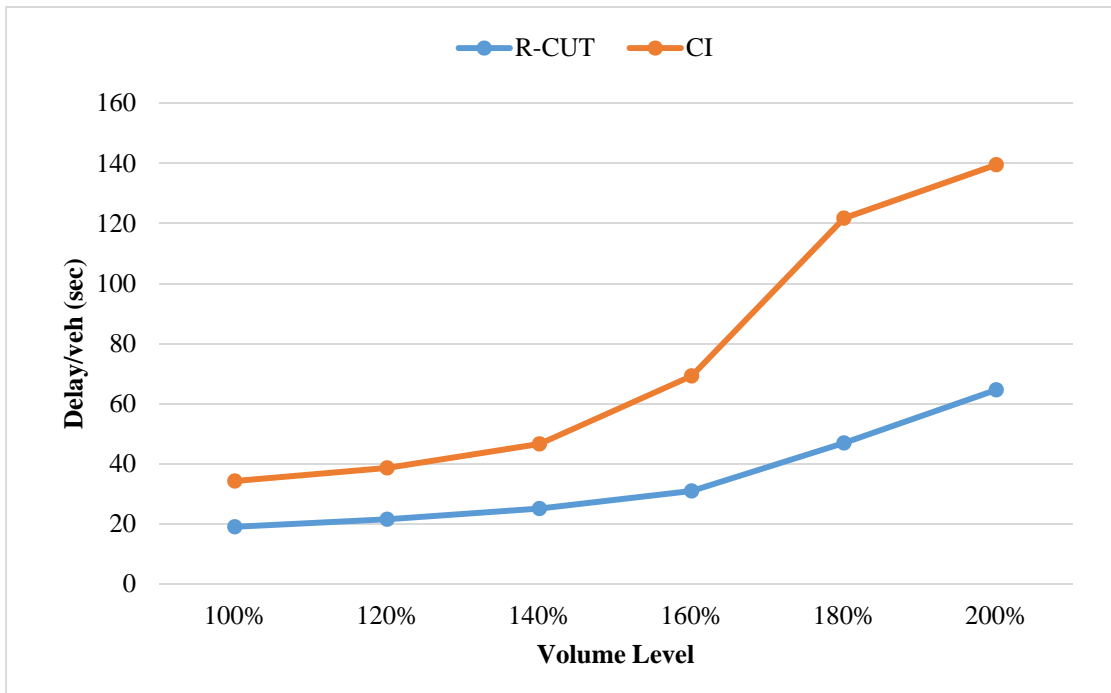

Figure 78: Volume Level versus Delay per vehicle between CI and RCUT Intersection



Table 27: Performance Measures Comparison by Movement — Volume Level 100%

Movement	Volume	Delay/veh (sec)		LOS		Travel Time (sec)	
		CI	RCUT	CI	RCUT	CI	RCUT
WBL	352	46.25	22.2	D	C	73.62	77.16
WBT	56	48.06	21.06	D	C	73.05	71.09
WBR	393	3.48	2.4	A	A	32.53	31.6
SBL	337	60.92	29.99	E	C	76.4	48.89
SBT	801	22.29	11.11	C	B	39.77	28.84
SBR	58	0.78	9.64	A	A	14.89	23.87
EBL	67	38.67	35.09	D	D	77.04	109.35
EBT	55	69.34	22.98	E	C	97.61	91.5
EBR	6	61.71	2.66	E	A	92.86	26.41
NBL	18	83.78	31.54	F	C	98.47	47.29
NBT	785	47.76	17.5	D	B	67.24	37.43
NBR	255	5.98	11.99	A	B	20.33	29.52



Table 28: Performance Measures Comparison by Movement—Volume Level 200%

Movement	Volume	Delay/veh (sec)		LOS		Travel Time (sec)	
		CI	RCUT	CI	RCUT	CI	RCUT
WBL	704	97.81	125.14	F	C	125.14	87.81
WBT	112	88.64	113.62	F	C	113.62	78.69
WBR	786	23.5	52.64	C	A	52.64	38.69
SBL	674	170.46	185.99	F	D	185.99	58.22
SBT	1602	48.35	65.97	D	B	65.97	36.56
SBR	116	6.36	20.48	A	B	20.48	27.37
EBL	134	57.15	95.7	E	D	95.7	123.88
EBT	110	77.92	106.75	E	D	106.75	104.51
EBR	12	58.58	88.82	E	A	88.82	27.88
NBL	36	101.76	116.58	F	D	116.58	55.81
NBT	1570	126.97	146.53	F	C	146.53	48.01
NBR	510	33.79	48.19	C	B	48.19	37.3

The comparison of performance measures between CI and RCUT was performed for each approach as well. Head to head comparison by movement in terms of delay per vehicle, level of service and travel time is presented in Table 27 for 100% volume level and Table 28 for 200% volume level. For 100% volume level, almost every approach for RCUT performed better than CI. Even the left-turn movement which used the U-turn crossover had the better delay and LOS as shown in Table 27. For example, WBL approach delay was changed from 46.25 sec to 22.20 sec, and level of service improved from D to C. Similarly, some indirect left-turns also performed better in terms of delay and LOS. However, indirect left-turns in RCUT design such as WBL and EBL needed to travel longer distance resulting higher travel time. For 200% volume level, some left-turn and right-turn for RCUT were affected in terms of delay and level of service. But, the major movements such as NBT and SBT performed very well under RCUT design as demonstrated in Table 28. Again, movements such as WBL, EBL and WBR suffered in some extent but all in all, RCUT performed better.

Overall, most of the movements performed better for RCUT design compared to CI. NBT, SBT, SBL, and WBL are some major movements represented large volume of the network, improvement on these approaches hugely contributed for better overall network performance.



3.3.7 Benefit to Time Saving

Generally, RCUT intersection produces high benefit-to-cost ratio when compared to the conventional intersection. However, the cost of construction is very high for RCUT. The cost of converting a conventional intersection to an RCUT intersection varies depending on the specific project context. The cost of construction depends on the aspects such as the number and length of additional lanes required, utility impacts, modifications to the existing signal system, amount of additional right of way, and access modifications. The right of way cost may change by geographical location of the intersection.

For the study intersection, delay savings by RCUT intersection compared to conventional intersection was calculated. Table 29 shows the benefit of RCUT over CI in terms of delay savings in one year. The cost of delay was used \$17.67/hr as reported by Texas A&M Transportation Institute for year 2014.

Table 29: Reduction of Cost by RCUT by Saving Delay

Volume Level	Total Vehicle Time Reduction (vehicle-hour/day)	One-year Cost Reduction (dollar)
100%	79.93	\$515,513
120%	106.74	\$688,424
140%	157.31	\$1,014,577
160%	317.57	\$2,048,173
180%	532.14	\$3,432,083
200%	685.28	\$4,419,720

3.3.8 Conclusion

The analysis highlighted several important aspects regarding RCUT traffic operations and demonstrated how RCUT can improve the overall performance compared to the existing condition. RCUT intersection reroutes through and left-turn movements from the minor streets to the median U-turn crossover, providing an easier maneuver at major street. RCUT intersection design significantly reduces the number of conflicts at the main intersection, leading to a more efficient and safer operation. Only two phases are required at the main intersection to accommodate the vehicles and pedestrians, which ensures a better operation at the major street. However, the movements at the minor road may experience higher delay and travel time due to their indirect movement using U-turn crossover. Vehicle-pedestrian conflicts are reduced significantly reduced using a “Z” shaped crossing in RCUT intersection. Pedestrian crosswalks may be longer for pedestrians to cross the major street when compared to the conventional intersection. Wayfinding is very important at RCUT intersection especially for drivers at Side Street who are not familiar with the intersection. The case study at a specific intersection showed



that RCUT intersection reduced the overall delay and travel time, and improved the level of service compared to conventional intersection. The RCUT design outperformed the conventional intersection in terms of delay and travel time for increased volume scenario as well. Overall, RCUT intersection performs better compared to conventional intersection.

3.3.9 MUT versus RCUT Intersection

Earlier, MUT and RCUT intersection design was evaluated and compared with the conventional intersection separately. The comparison between MUT and RCUT can also be made because both designs were simulated for the same existing intersection location. In this particular intersection, RCUT was slightly superior to MUT design on the basis of operational performance. The overall network performance of MUT and RCUT intersection is shown in Table 30. The overall delay in each volume level is reduced for RCUT compared to MUT intersection. RCUT also improved average speed and total travel time. In addition, Figure 79 demonstrated comparison of overall delay for each volume level between RCUT and MUT design which showed RCUT had lesser delay for each volume level. Travel time was also in the same pattern.

Table 30: Overall Network Performance Comparison between MUT and RCUT Intersection

Overall Network Performance	Volume Level	Input Volume	Throughput	Delay/veh (sec)	LOS	Average Speed (km/hr)	Total Travel Time (sec)
MUT Intersection	100%	3,183	3,100	23.53	C	49.99	222,476
	120%	3,820	3,746	26.93	C	47.69	281,277
	140%	4,456	4,376	30.64	C	45.43	345,640
	160%	5,093	5,007	36.12	D	42.43	423,838
	180%	5,730	5,576	47.59	E	37.28	539,097
	200%	6,366	5,659	90.13	F	25.38	802,292
RCUT Intersection	100%	3,183	3,103	19.09	B	52.25	206,142
	120%	3,820	3,753	21.58	C	50.36	258,195
	140%	4,456	4,387	25.15	C	47.83	318,049
	160%	5,093	4,984	30.97	C	44.26	391,065
	180%	5,730	5,312	46.94	D	37.20	505,888
	200%	6,366	5,517	64.61	E	30.60	635,138

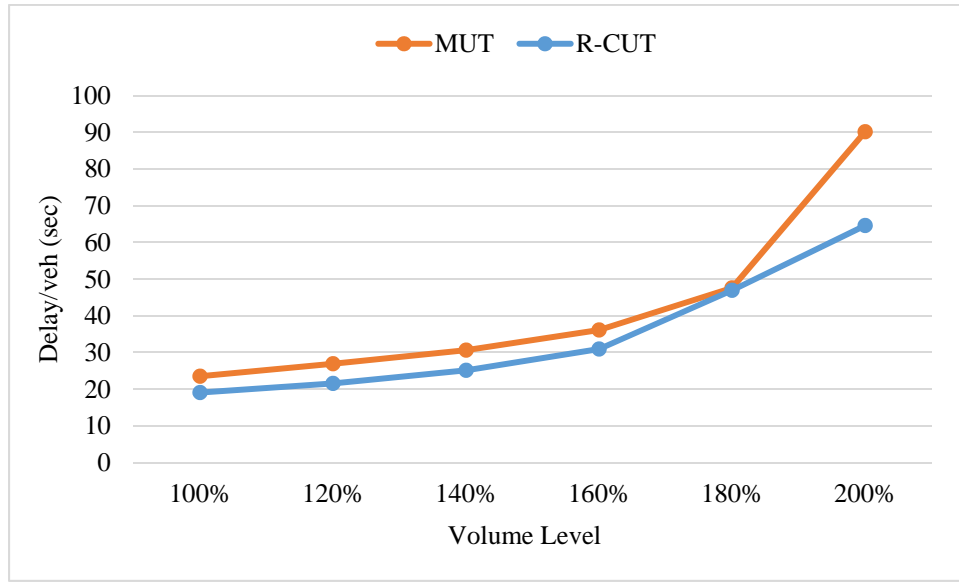

Figure 79: Comparison of Overall Delay between RCUT and MUT for Volume Level

Certain approaches with high volume played the role for better performance of RCUT over MUT. The operation of left-turns at major road and through movement at minor road differed in MUT and RCUT. NBL and SBL in MUT design required to use U-turn crossover while WBT and EBT in RCUT design required using U-turn crossover. Figure 80 and Figure 81 showed the comparison of delay by movements between RCUT and MUT for 100% and 200% volume level respectively. The major difference in delay was observed for WBL and SBL movement. In the study intersection, the volume of the WBT and EBT movements were comparatively less in comparison to SBL and NBL movement. In addition, the NBL volume was very light compared to SBL that increased the green time proportion in SBT direction in RCUT design. According to the design, WBL goes through SBT movement, which showed the advantage of RCUT over MUT for that particular movement of the study intersection. On the other hand, direct movement of WBT and EBT traffic in MUT intersection was the main benefit over RCUT. However, the volume in WBT and EBT movement was considerably lower compared to SBL and WBL movement. Therefore, the improved operations of WBL, SBT and SBL movements in the RCUT design showed that RCUT was a better alternative than MUT for the study intersection.

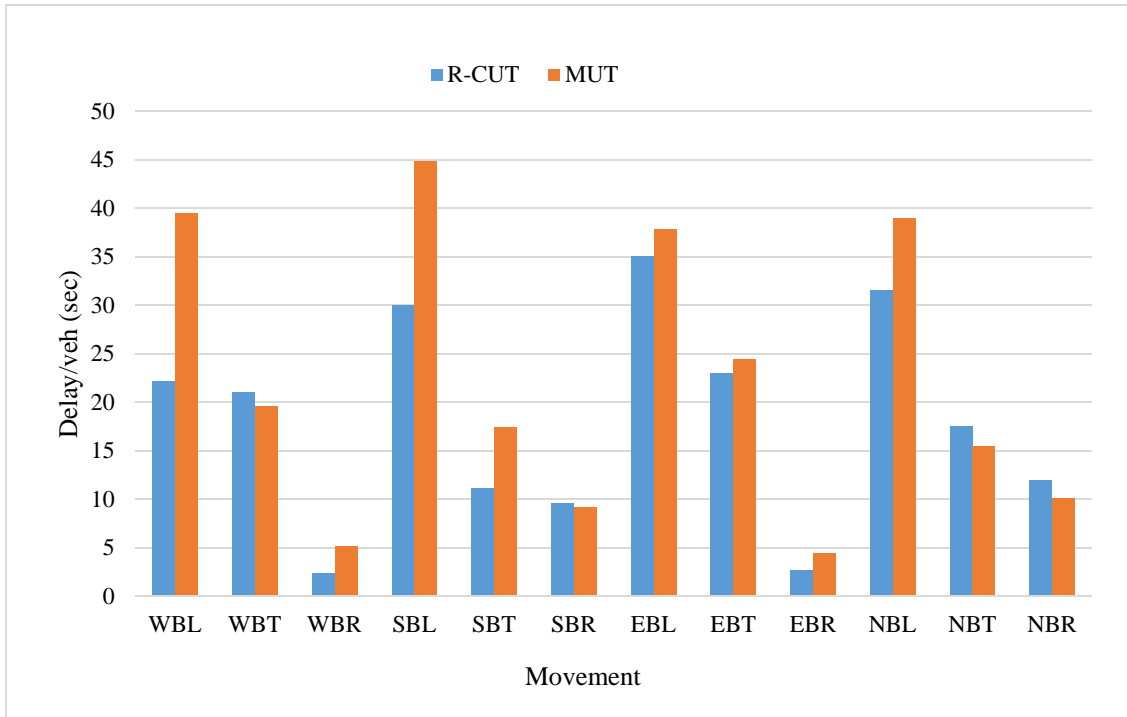

Figure 80: Delay by Movements Comparison between RCUT and MUT (100% Vol Level)

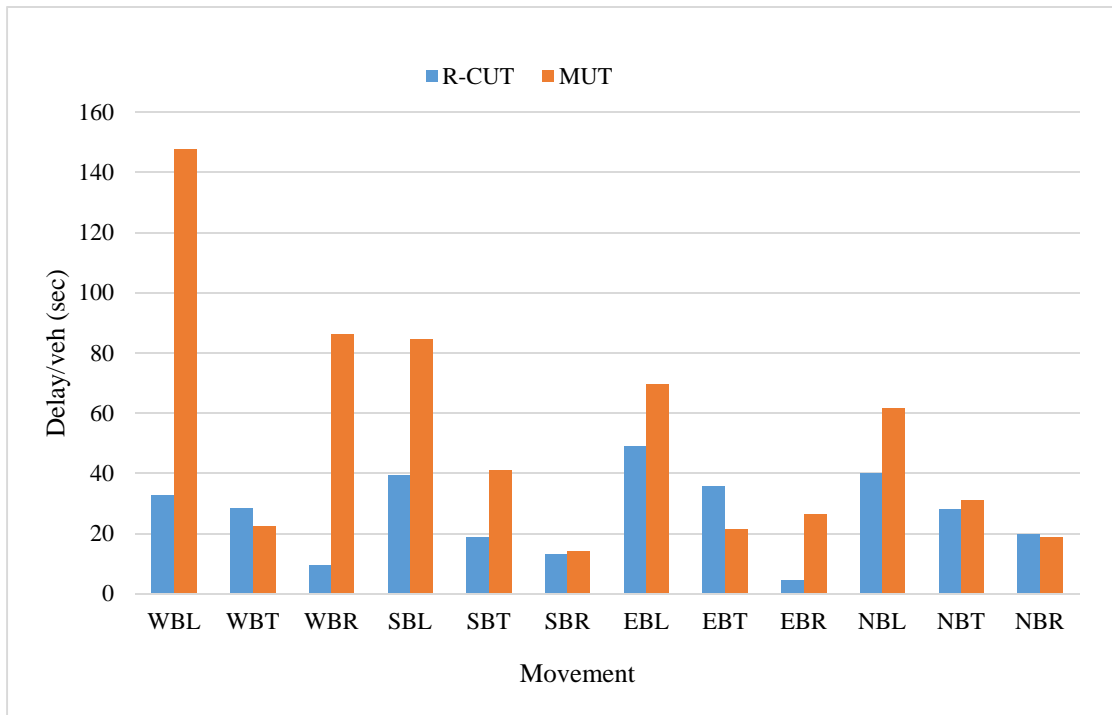

Figure 81: Delay by Movements Comparison between RCUT and MUT (200% Vol Level)



3.4 Diverging Diamond Interchange (DDI)

3.4.1 DDI Overview and Study Area

The Diverging Diamond Interchange (DDI) is a form of an interchange along freeways and works at most urban, suburban and rural areas with heavy volume of left turns on to and off of freeway ramps. It is known as Double Crossover Diamond (DCD) Interchange. This alternative design can be implemented as an underpass or an overpass at moderate but unbalanced crossroad traffic volumes through the interchange. DDIs are usually retrofits of existing diamond interchanges, which have left turn related safety concerns at the interchange intersections, and there is a need for additional capacity without widening the roadway or the bridge. In addition, according to the Figure 82, it is also found that DDI improves traffic safety compared to the conventional interchange by significantly reducing the number of vehicle-to-vehicle conflicts.

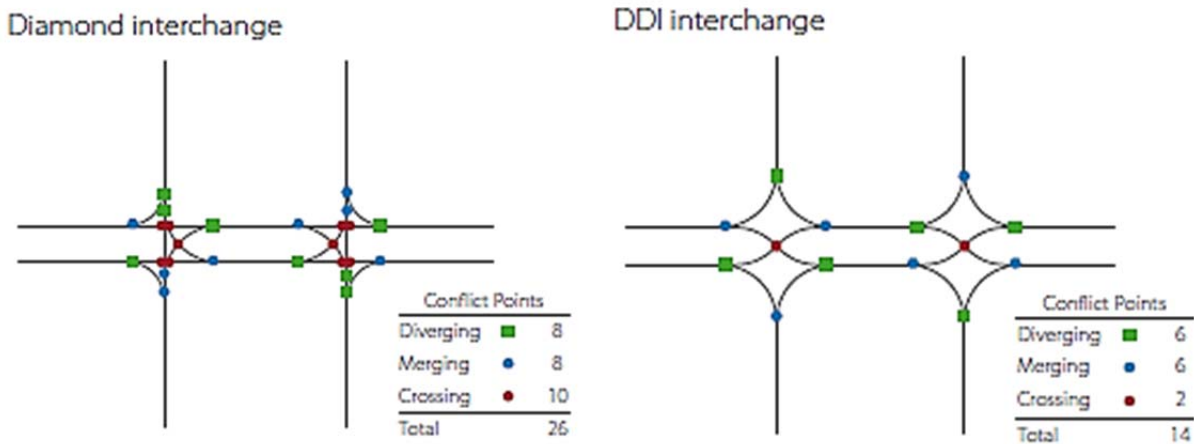

Figure 82: Conflict Points for Diamond Interchange and DDI Interchange

The existing conventional diamond interchange (CDI) in this study is located in an urban area in Orlando, Florida along SR 417 Ramps at Lake Nona Blvd, as shown in Figure 83. This interchange has two intersections controlled by traffic signals. The north intersection is 4-legged with SR 417 SB ramp running only in the west direction while Lake Nona Blvd running North-South. The south intersection is also 4-legged with SR 417 NB ramp running only in the east direction while Lake Nona Blvd running North-South. Lake Nona Blvd is a 4-lane divided road north of SR 417 and 6-lane divided arterial south of SR 417 with the posted speed limit of 30 mph. SR 417 SB ramp and NB ramp are connectors to the SR 417 (freeway) with a “Reduce Speed” sign. The laneage at the north intersection consists of one exclusive left turn lane, two through lanes on the south approach, two through lanes shared with right turn on the north approach, and one exclusive left turn lane, one exclusive right turn lane on the east approach. Similarly, the laneage at the south intersection consists of one exclusive left turn lane, two through lanes on the north approach, two through lanes and one exclusive right turn lane on the south approach, and one exclusive left turn lane, one exclusive right turn lane on the west approach. All left turn movements operate with protected phases only. Based on the field observation as shown in Figure 83, the left turns for westbound on the north interchange is 314

vehicles per hour, which is relatively higher than other movements. In comparison, the through movements for southbound on the south interchange is 416 vehicles per hour, which is also relatively high in this interchange.

In this study, the purpose of this task is to identify if the DDI performs better than the conventional diamond interchange and if the current interchange need to be retrofitted by the DDI. As a result, preferred performance measures will be established and the preferred techniques for monitoring will be identified.

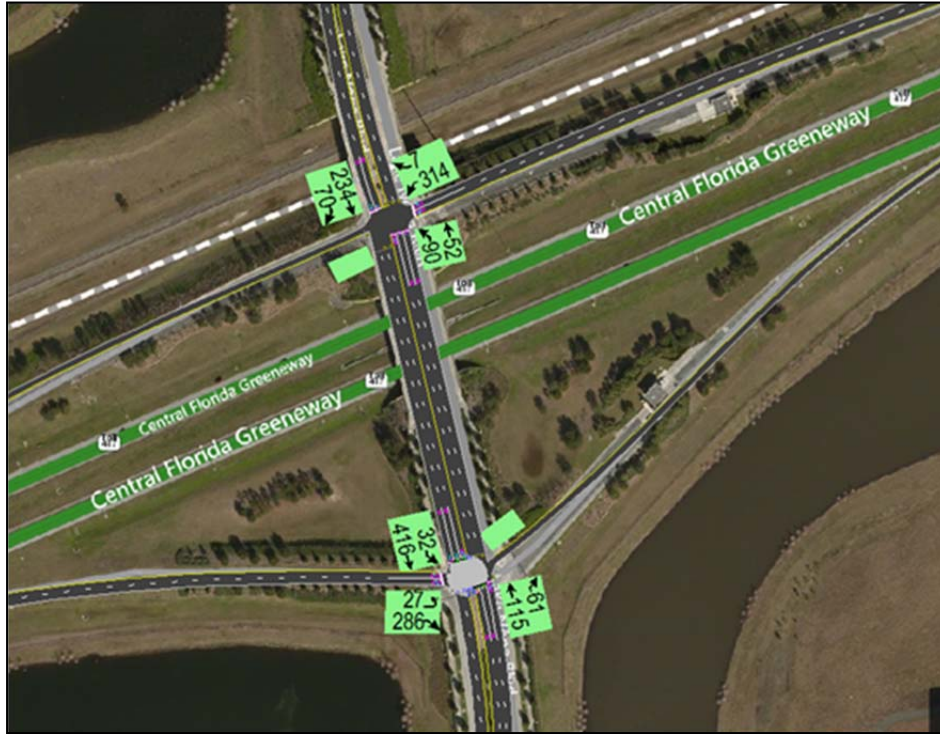

Figure 83: Study Interchange – SR 417 Ramps at Lake Nona Blvd

3.4.2 Right of Way

The inbound and outbound movements during the crossover may be channelized to guide the drivers through the complex movement and onto the proper lanes. DDIs hardly require any extra right of way when being retrofitted from conventional diamond interchanges. The DDIs need to implement terminal directional crossovers for the freeway facility's entering and exiting movements. First, the crossover angle may affect the frequency of wrong-way maneuvers. Therefore, DOT recommends crossovers to be 45 degrees or larger to avoid any wrong way movements. Second, the crossover distance depends on the right of way available, so the DDI provides flexibility when it comes to choosing this distance. Usually, when the crossover distance is less than 700 feet, the DDI tends not to perform as well operationally, especially with moderate to high through volumes. In comparison, longer crossover distances (700 to 1500 feet) can provide better operations and signal flexibility. In this case, the crossover distance is around

700 feet so that the DDI can perform well when being retrofitted from the conventional diamond interchanges. Third, auxiliary lanes may be used on these alternatives to assist weaving traffic. The auxiliary lane can reduce weaving and improve both through movement and turn movement capacities. In addition, interchanges with overpass design have more flexibility and have the ease of adding lanes to the existing roads by building a parallel structure. DDI's radii must accommodate the new left turns onto the ramps; this will entail extra pavement and possibly additional bridge structure. In conclusion, the study interchange is well fit to be retrofitted by DDI. The anatomy of the DDI is shown in Figure 84.



Figure 84: Anatomy of the DDI

3.4.3 Pedestrian and Bicyclist Interaction

Typically, there are two types of pedestrian facilities, including walkways outside the vehicular through travel way and walkways in the median between the vehicular directions of travel. For the underpass DDI, pedestrian walkways on the outside the vehicular through travel way is recommended to avoid conflicts with bridge columns placed between the two directions of vehicular traffic. However, for the DDI with overpass design, pedestrian facilities in the median of the interchange is recommended since it can diminish pedestrian and left turning conflicts from the freeway traffic. Therefore, the center walkways are applied in this interchange, as shown in Figure 85.

Pedestrian crossings at a DDI can be signalized or unsignalized. For the center walkways, pedestrian crossings are usually signalized at the crossover, but may not be signalized on the turn lanes to and from the freeway. In this case, interchanges with overpass provide pedestrian crossing phases with concurrent vehicle phases. Right turns do not provide restricted pedestrian



signals so vehicles need to look out and yield to the crossing pedestrians. The median center crosswalks need to be signalized and protected by barrier walls to provide safety for the crossing pedestrians. In addition, cut-through walkways on the cut-through islands can help guide the pedestrians through the crossing path; they should be at least eight feet wide to accommodate all pedestrians. Landscaping can be utilized to define the walkway boundaries instead of cut-through walkways. The pedestrian navigation is shown in Figure 85.

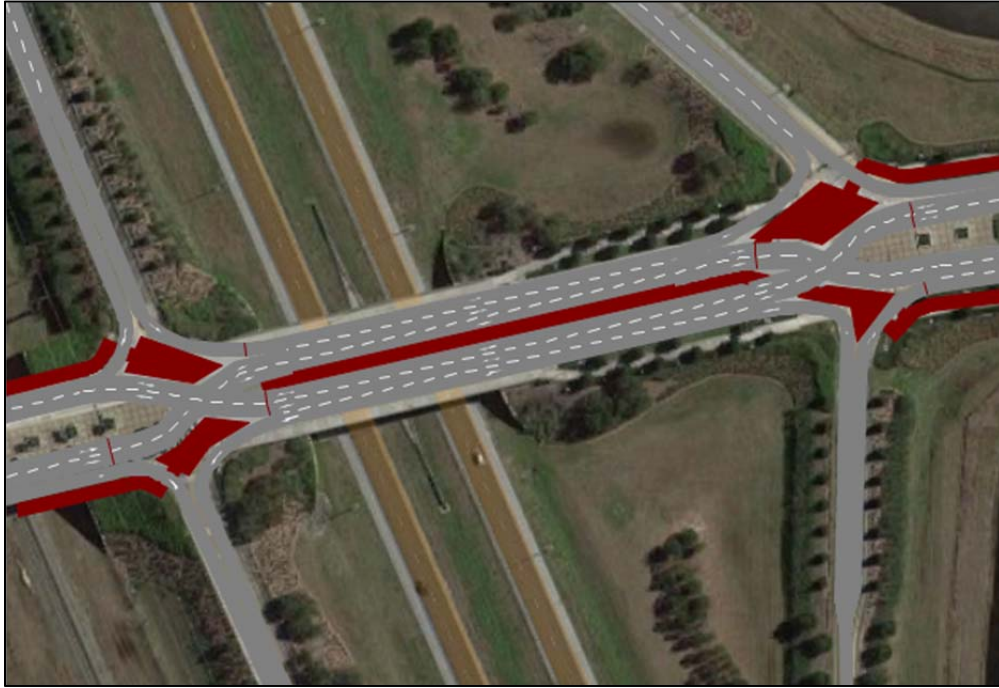

Figure 85: DDI Pedestrian Navigation

Accessibility to pedestrians with disabilities and vision and/or mobility impairments should be accounted for. The Americans with Disabilities Act (ADA) and the Public Rights-of-Way present policies and guidelines which need to be accounted for to have an intersection that can accommodate all pedestrians. Pedestrian walkways must be delineated through landscaping, curbing, or fencing in order to accommodate vision-impaired pedestrians. Slopes should be provided for wheelchair users and strollers. Curb ramps and detectable warning surfaces at the edge of sidewalks should be provided. Locator tones and audible speech messages need to be provided at pedestrian signals to assist blind pedestrians. Signals will require locator tones to guide vision-impaired pedestrians to the push buttons. Push buttons need to be accessible by wheelchairs. The crosswalk widths should be wide enough to allow pedestrians and wheelchairs to cross without delays.

Bicycle users can be accommodated in the DDI. Some have constructed bicycle lanes through the crossovers. Others have been built with bicycle paths to be shared-use on the outside of the interchange. The reduced crossing distance results in extended crossing time for bicyclist and less vehicle exposure. There are three bicyclist accommodations in the DDI

- 1- Marked bicycle lanes through DDI



- 2- Shared-use path or separate bicycle path
- 3- Shared vehicular lanes

In this case, less than five bicyclists occurred during the two observation days. Therefore, bicyclists are recommended to share path with pedestrians. Additionally, shared-use paths for pedestrians and bicyclist are required to be a minimum 10 ft.

3.4.4 Wayfinding

Wayfinding is very important in the DDI alternative, they are used to regulate, warn, and guide vehicles through the new alternative. Two kinds of wayfinding are covered in this section including signing and pavement marking. Proper signing and pavement marking can be an effective aid in moving drivers through the DDI correctly.

The types of signs include regulatory signs, warning signs, and guide signs. Regulatory signs instruct users on where and what they need to do to get where they want to go. Some of these signs include “No Right Turn”, “Do Not Enter”, “Wrong Way”, “One Way”, “Stay Right”, and many more. Warning signs advise the vehicles of any hazardous operations; these include lane split, reverse curve, yield ahead, and many others. Guide signs show routes and directions to destinations or paths. They can display distances and city street/city designations. There should be a sign located before the crossover, another past the first crossover, and the third sign guides the users to the ramps. The signs in this case are shown in Figure 86.

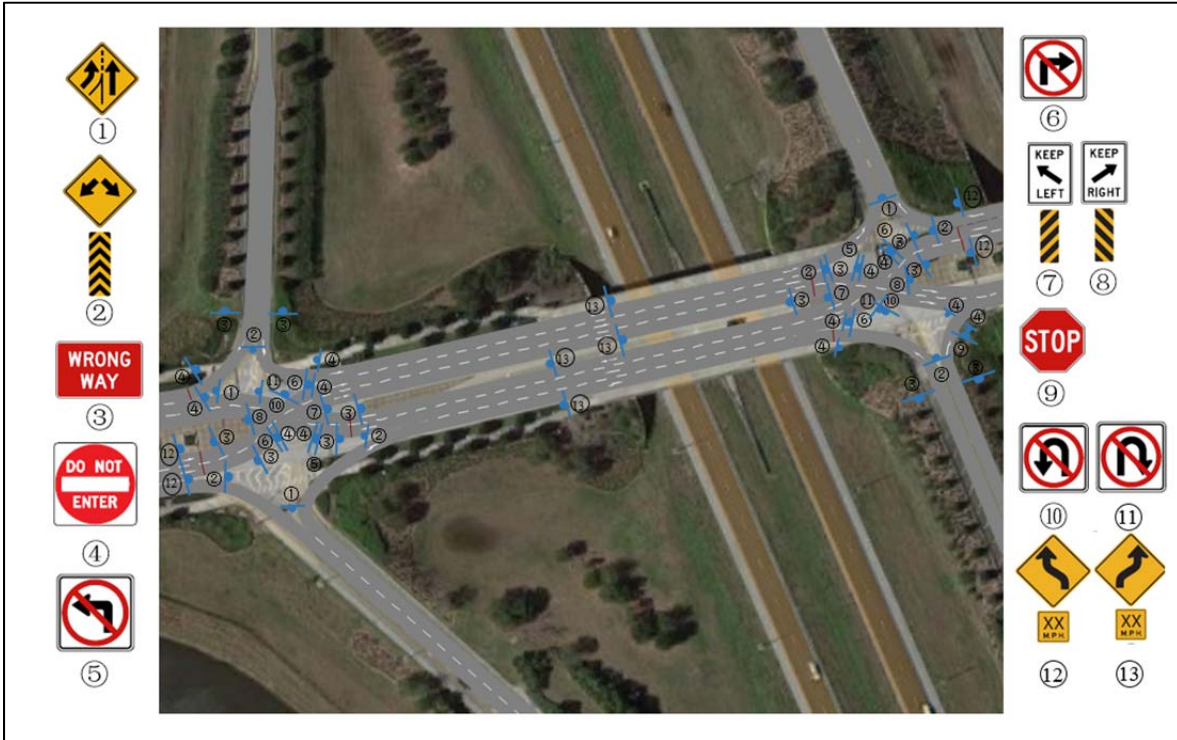

Figure 86: DDI Signing

Pavement markings define vehicle entry and exits for the ramps and the crossovers. They also delineate the multimodal paths for bicyclist and pedestrians. Some DDIs use white lines for left side lanes and yellow lines for right side lanes due to the crossover. Solid lines are used to discourage lane changing; they are useful on the cross street at the crossovers. Lane use arrows placed on the pavement guide vehicles through the DDI. Stop bars are used at signalized intersections and yield lines are used at unsignalized exit/entry ramps. Crosswalk markings are also required to guide pedestrians through the paths. Lighting needs to be provided at pedestrian crosswalks, ramp exit/entry points, and conflict points.

3.4.5 Signalization

The DDI signal usually operates with split phasing to allow both crossover movements to proceed independently. Therefore, the timing and coordination of signals at DDI is different with the conventional diamond interchange. In general, pre-timed control and actuated control are two options for interchanges. In a coordinated signal system, actuation is used to give additional time to heavy movements if that time is not needed for oftentimes lower-volume side street or turning movements. However, at the DDI, there is no “side-street” movement at the signal. Therefore, actuated signal control may not provide the same level of benefit as at a conventional intersection and a pre-timed signal control is recommended at a DDI.

DDI has a reduced number of signal phases and operate as a two phased system. This reduction progresses overall signal efficiency and improves cross street through traffic and left turns from the freeway. The left turn movements exiting the freeway are signalized or yield controlled. The yield control left turns with no acceleration lanes is applied at areas with low to modern traffic volumes. Signalized left turn movements are recommended when pedestrian facilities are in place. Since the westbound left turn movements are heavy, the signalized phase for the westbound left turn movements is recommended. Although the right turn on red are not common at DDI ramps, the signalized control for the eastbound right turn is still recommended because of the heavy right turn volume. Besides, all other left turn movements and right turn movements are controlled with yield sign due to the low traffic volume (Figure 87).

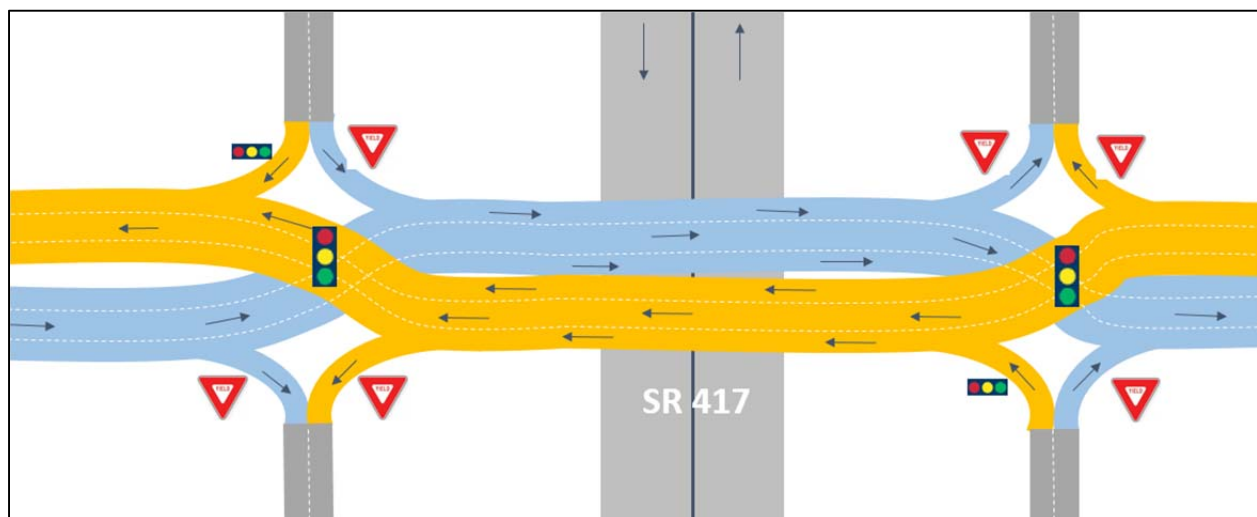

Figure 87: DDI Signal Phasing

Pre-timed signal are recommended to assure efficient progression across the cycles. Typical cycle lengths range from 60 to 90 seconds. In this case, the cycle length depends on the traffic volume. Several trials for different signal timing plans were tested in VISSIM in order to arrive at the best signal timings based on the network performance, such delay and average speed. The DDI timing sequence is shown in Figure 88.

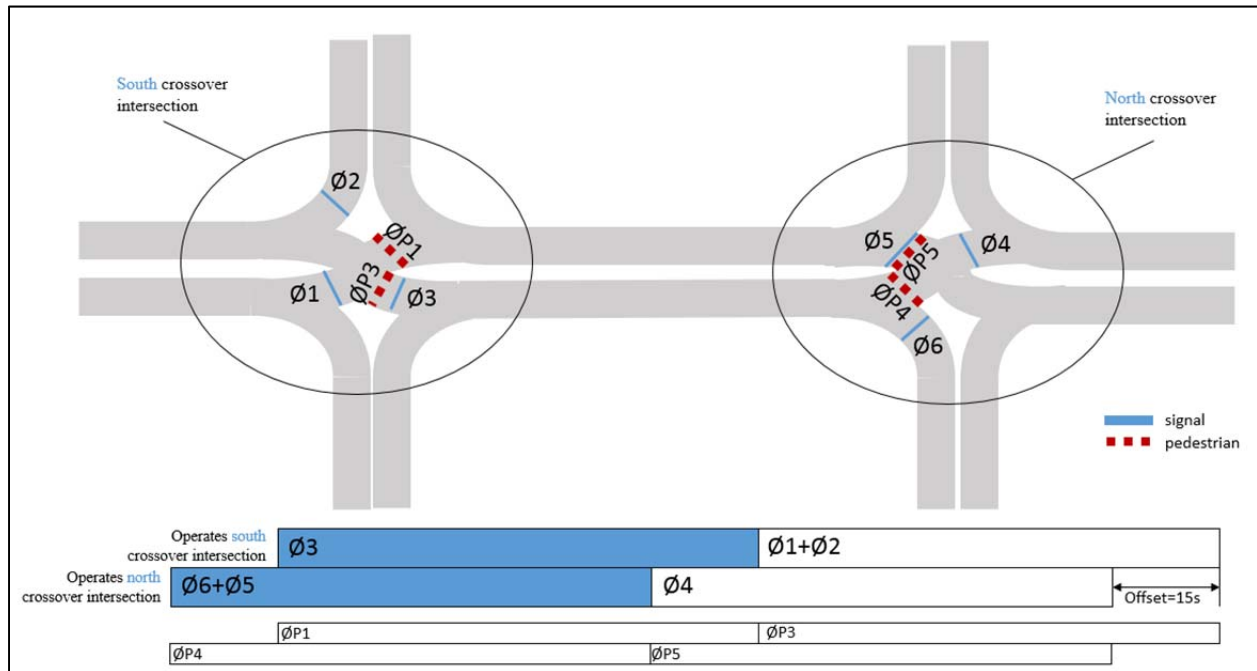

Figure 88: DDI Signal Phasing Diagram

3.4.6 Traffic Evaluation

3.4.6.1 VISSIM Modeling

In order to evaluate the difference between the DDI traffic characteristics and the CDI traffic characteristics, traffic microsimulation software is needed. In this study, VISSIM is selected as the appropriate tool since VISSIM is robust and flexible microsimulation software that can reflect the traffic condition of DDI and CDI. Additionally, Synchro is also used to optimize the signal timing for the existing condition.

In this study, VISSIM version 6.0 was used to develop the simulation mode at SR 417 Ramps at Lake Nona Blvd. Wiedemann 74 car-following model was used since it was recommended for urban traffic. The first step of developing the VISSIM model was to draw the network. The network geometry such as the lengths of the links (length of roadway) and number of lanes was extracted from Google Maps. Secondly, traffic volumes were allocated to each lane group including the real percentage of trucks. Thirdly, the signal was set up in the VISSIM simulation model according to the actual signal timing data from the City of Orlando. Last but not the least,



conflict areas and priority rules were needed in the simulation model in order for the VISSIM model to simulate the vehicle movements more practically.

A VISSIM model showing an existing condition does not become reliable until the model is calibrated and validated. The calibration and validation of VISSIM model need to reflect the local traffic condition, including lane geometries, driver behaviors, turning movements, signal timing, etc. Therefore, field data, including network geometry, turning movement, signal timing, truck percentage, were collected for the study intersection on March 17th, 2015 to calibrate and validate the VISSIM model.

3.4.6.2 Experimental Scenarios

In order to compare the CDI and DDI alternatives and based on the existing design, more experimental design scenarios were explored. First, since the traffic volume is relatively low in the study interchange, traffic volumes started at the current conditions and incrementally increased up to three times of that of the current conditions executed in five levels. Therefore, the impact of increasing traffic volume was carried out by modeling the volumes with 50% increments resulting in five different experimental scenarios. Second, the CDI was changed into DDI in VISSIM according to the Utah Department of Transportation (2014). The parameters that include driver behavior, turning movements, speed limits, remained the same, except for lane geometry and signal timing. Therefore, the final experiment resulted in $5 \times 2 = 10$ multilevel factorial. CDI was modeled in Synchro to optimize the signal timing for each scenario and then the optimized signal timing data were applied in VISSIM. However, DDI was difficult to model in Synchro so that the signal timing of DDI was optimized in VISSIM. As shown in Figure 83, the westbound left and southbound through turning movement volumes at the north intersection were 314 and 234 vehicles per hour, respectively. The eastbound right and southbound through turning movement volumes were 286 and 416 vehicles per hour, respectively. Therefore, these heaviest traffic movements affected the operation of the intersection and determined the signal timing phasing. To accommodate this type of unbalanced traffic distribution patterns, the signals were set up at the westbound left lane of the north intersection and the eastbound right lane of the south intersection. Other left turns or right turns used the yield sign. In addition, a pre-timed signal was applied in DDI, since the pre-timed signal could achieve some level of traffic progression for both directions of traffic to the extent possible (Schroeder et al., 2014). Several trials for different signal timing plans were tested in VISSIM in order to arrive at the best signal timings based on the network performance, such as delay and average speed. Furthermore, the simulation time was 60 minutes in each scenario. A total of three runs with different seeding values were completed for each scenario and the average of the runs was reported. Graphical representations of the VISSIM models for both CDI and DDI are shown in Figure 89.



Figure 89: CDI and DDI VISSIM Model

3.4.6.3 Analysis and Results

Based on the output of VISSIM, the overall network performance for each scenario was summarized in Table 31. The input volume, throughput volume, total delay per vehicle, level of service, and average speed were included. The results show how the network performance measures of DDI changed compared to the CDI when the traffic volume increased. Figure 90 illustrates the hourly throughput in each volume level for CDI and DDI. Figure 91 demonstrates the relationship between the delay at each volume level for CDI and DDI.



Table 31: Overall Network Performance Measures for CDI and DDI

Overall Network Performance	Volume Level	Input Volume (veh/h)	Throughput (veh/h)	Delay/Vehicle (sec)	LOS	Avg Speed (km/h)
CDI	100%	1114	1101	16.06	B	37.8
	150%	1691	1666	30.02	C	27
	200%	2250	2079	128.84	F	10.84
	250%	2813	2332	150.53	F	9.06
	300%	3389	2721	141.61	F	9.43
DDI	100%	1126	1105	15.65	B	40.52
	150%	1671	1649	18.59	B	38.54
	200%	2233	2190	22.38	C	36.2
	250%	2794	2727	35.97	D	29.81
	300%	3343	3102	51.59	D	24.72

As shown on Figure 90, the throughput of DDI was almost the same as the throughput of CDI when the traffic volume was under 2000 veh/hr. However, as the traffic volume increased, there was a significant difference between CDI and DDI in throughput. The percent increase in throughput for DDI over 200% traffic volume compared to the CDI ranged from 5-16%. In addition, when the traffic volume level was 250%, the throughput of CDI was much more than the input volume. In other words, the traffic volume reached the maximum capacity for CDI. In comparison, the input volume was almost the same as the throughput for DDI at 250% volume level. Therefore, DDI could raise the capacity of this interchange compared to the CDI. Furthermore, Figure 91 also showed the significant difference between CDI and DDI in delay when the traffic volume was over 200% level. Therefore, DDI outperformed the CDI with respect to throughput volume and delay. In conclusion, compared to the CDI, DDI could not only raise the maximum capacity of the interchange, but also improve the network performance with respect to the delay.

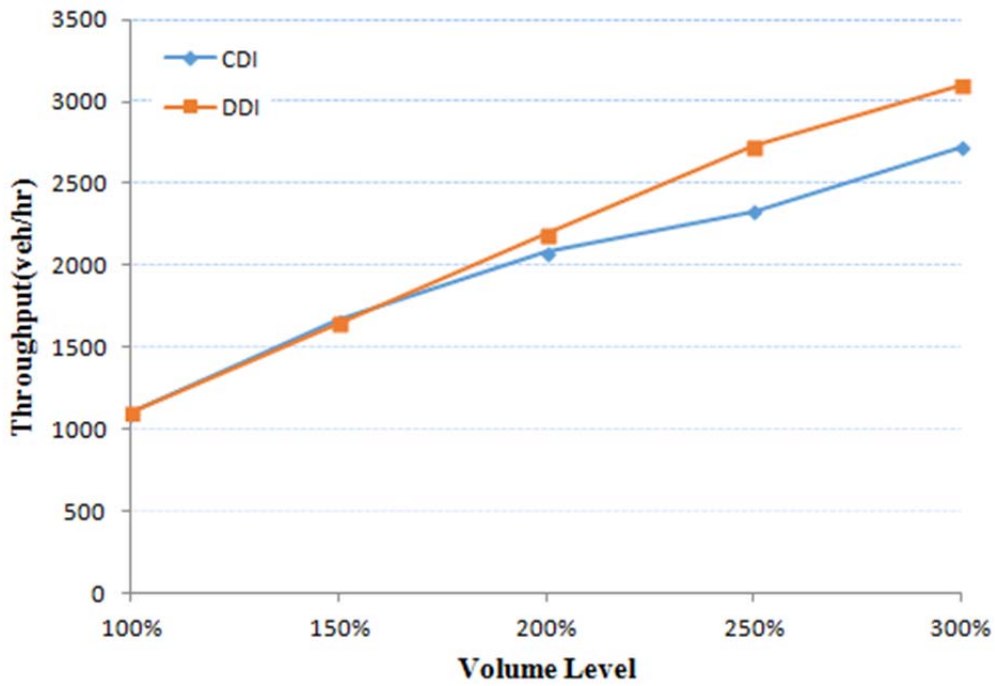

Figure 90: Volume Level versus Hourly Throughput between CDI and DDI

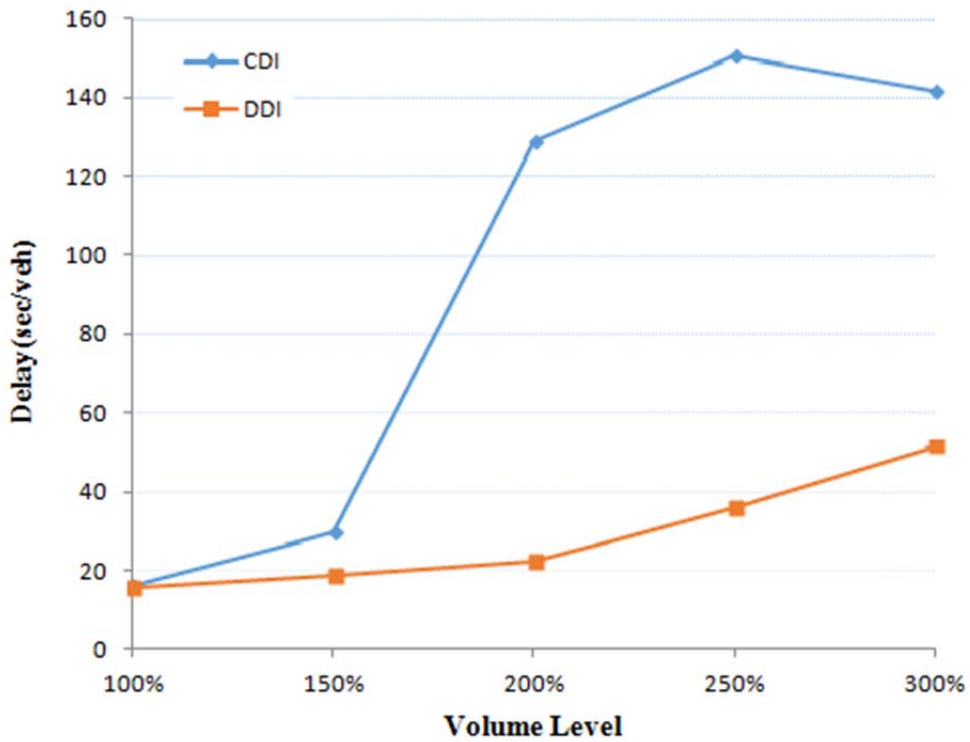

Figure 91: Volume Level versus Delay between CDI and DDI



Table 32 and 33 summarized the performance measures by movement for CDI and DDI for the existing conditions base scenario which is at the 100% volume level as well the scenario which is at the 300% volume level, respectively. At the 100% volume level, DDI improved the performance of some movements compared to CDI, including the westbound left (WBL) and northbound left (NBL) at the north interchange, and eastbound left (EBL) and southbound left (SBL) at the south interchange. At the 300% volume level, DDI even improved the performance for six approaches according to the delay. According to the level of service (LOS) shown in Table 33, westbound right (WBR) and westbound left (WBL) were failing in CDI at 300% volume level. However, these two movements were improved significantly in DDI at 300% volume level. In addition, there was a problem with the eastbound right (EBR) for DDI at the south interchange. This movement failed because the signal was set up at this movement in order to reduce the conflicts to the southbound through vehicles. Therefore, the space may not be available for this approach. The same problem might happen to the EBR for 300% scenario. Therefore, it is recommended to add more space for EBR when being retrofitted to the DDI interchange. In general, DDI improved the performance of the interchange for most movements at different levels of volume.

Table 32: Performance Measures Comparison by Movement — Volume Level 100%

Movements		Volume	Delay/Veh		LOS		Queue Length Max	
			CDI	DDI	CDI	DDI	CDI	DDI
North	WBR	7	1.01	0.47	A	A	3.07	44.87
	WBL	314	27.75	8.87	C	A	75.80	1.65
	SBT	234	9.17	13.30	A	B	28.56	26.67
	SBR	70	3.51	0.65	A	A	33.88	0.00
	NBT	52	5.12	2.32	A	A	16.78	18.83
	NBL	90	28.06	1.06	C	A	24.16	0.00
South	EBR	286	2.69	14.47	A	B	13.97	0.00
	EBL	24	31.36	1.12	C	A	13.95	62.92
	SBT	416	1.90	8.52	A	A	24.38	33.49
	SBL	32	20.27	0.92	C	A	14.96	7.57
	NBT	115	3.60	12.14	A	B	20.66	22.42
	NBR	61	0.63	0.58	A	A	1.65	0.00



Table 33: Performance Measures Comparison by Movement — Volume Level 300%

Movements		Volume	Delay/Veh		LOS		Queue Length Max	
			CDI	DDI	CDI	DDI	CDI	DDI
North	WBR	21	250.21	5.58	F	A	9.41	5.52
	WBL	942	365.63	28.70	F	C	411.20	221.08
	SBT	702	14.64	15.43	B	B	88.19	60.69
	SBR	210	12.02	1.71	B	A	93.50	0.00
	NBT	156	3.34	4.47	A	A	26.99	21.05
	NBL	270	58.21	1.60	D	A	126.78	0.00
South	EBR	858	16.29	101.72	B	F	187.35	339.64
	EBL	72	60.28	53.01	D	D	50.32	0.00
	SBT	1248	3.65	11.91	A	B	62.09	98.47
	SBL	96	55.92	2.14	D	A	28.01	9.72
	NBT	345	6.42	13.59	A	B	52.86	34.07
	NBR	183	1.24	1.21	A	A	18.21	5.98

3.4.7 Benefit to Time Saving

DDI have a high benefit-to-cost ratio. DDI's construction costs are reduced when compared to typical interchange designs such as cloverleaf ramps. DDI's footprint typically fits the right of way and the bridge of the existing interchanges. This makes it less expensive and quicker to construct. The biggest factor in interchange cost is the structural cost; this is why DDIs are commonly implemented as retrofits. According to the cost of the DDI that have been built around the United States, the average construction cost for retrofits ranged between 3 and 8.5 million dollars. The difference between each scenario at each time period was calculated and multiplied by \$17.67/hour to determine the benefit of the time savings.

For the study intersection, there is no way to calculate the construction cost of DDI. But the benefit of the DDI by reducing the delay can be calculated for each volume level. Table 34 shows the benefit of DDI in one year.



Table 34: DDI Benefit to Time Saving Compared to the Existing Interchange

Volume Level	Total Vehicle Time Reduction (vehicle-hour/day)	One-year Cost Reduction (dollar)
100%	0.77	4,962
150%	31.83	205,305
200%	396.21	2,555,367
250%	533.47	3,440,627
300%	501.56	3,234,846

3.4.8 Conclusion

The analysis highlighted several important aspects regarding DDI traffic operations in the case of unbalanced volumes and demonstrated how DDI can improve the overall performance compared to the existing condition. When the conventional diamond interchange has a heavy volume on the left turns, CDI usually can be considered to be retrofitted by DDI. First of all, DDI improves traffic safety compared to the conventional interchange by significantly reducing the number of vehicle-to-vehicle conflicts based on the conflict analysis. In addition, compared the existing condition to the DDI at the 100% traffic volume, DDI can reduce the delay of all left turn movements and improve the level of service for left turn approaches at both intersections. Last but not the least, if traffic volume increases in the future, DDI have more benefits on the capacity and delay savings.



3.5 Quadrant Roadway Intersection (QRI)

3.5.1 QRI Overview and Study Area

The intersection under study is located in Orlando, Florida along Dean Road at University Boulevard. The intersection is 4-legged with Dean Road running in the north-south direction while University Boulevard running east-west. Dean Road is a 4-lane divided road south of University Boulevard and 2-lane divided road north of University Boulevard with posted speed limit of 45 mph. Similarly, University Boulevard is operated as a 6-lane divided road in both east and west direction with speed limit of 45 mph. Dean Road has two exclusive left-turn lanes, and two through lanes one of them shared with right turn on south approach, and it has two exclusive left-turn lanes, two through lanes, and one exclusive right-turn lane on north approach. University Boulevard has two exclusive left-turn lanes and three through lanes one of which is shared with right turn on east approach, while it has two exclusive left-turns, three through lanes and one exclusive right turn lane on the west approach. The storage lengths in all approaches ranges from 300 to 400 feet except on west approach which is extended all the way to SR 417 north exit on University Boulevard. All the left-turn movements operate with protected phases only and right-turn movements should yield to the conflicting movements. This intersection is considered appropriate for Quadrant Roadway Intersection (QRI) design because it is experiencing recurring congestion in the PM peak hours. The through traffic in east-west direction is heavy and other movements including all left-turn movement, has moderate traffic. In addition, there is an existing roadway in east-south quarter where the quadrant roadway as in Quadrant Roadway Intersection design could be operated. Therefore, a QRI design was evaluated as the build scenario and compared to Conventional Intersection (CI) in search of a rational alternative to minimize the intersection congestion especially for future conditions.



Figure 922: Study Intersection—Dean Road at University Boulevard (Orlando, FL)

3.5.2 Right of Way

A QRI can be among the least costly of the alternative intersections to construct and maintain, especially if there were existing streets to serve the function without the construction of a new roadway connector. Also, QRIs with one connecting roadway quadrant are the cheapest in terms of the right of way costs when compared to two-connecting roadway quadrants. At a minimum, a spacing of 500 feet from the center of the main intersection to the center of the secondary intersections is recommended. With 500 feet spacing between the main and secondary intersections and 90-degree intersection angles, there is sufficient area to fit a curve radius with 30 mi/h design speed on the connecting road. In some cases, a four to five lane cross-section connecting roadway may be needed to accommodate very high traffic volumes. However, right-of-way widths and costs grow proportionally for the wider connecting roadways, but the delay savings and other benefits may be worthwhile.

For the study intersection, 4-lane one-connecting roadway quadrant located at the east-south quarter of the intersection was designed for the evaluation. There was an existing quadrant road where the new roadway quadrant can be constructed. However, a wider 4-lane quadrant roadway connector was designed as shown in Figure 93. Therefore, the additional right-of-way for the wider roadway is needed for the study intersection.



Figure 93: QRI Design for Study Intersection

3.5.3 Pedestrian and Bicyclist Interaction

The pedestrian crossing is located at the same location as the conventional intersection as shown in Figure 94. Pedestrian movement is easier and shorter to cross a QRI than a conventional intersection due to the removal of the left turn lanes at the main intersection. QRI has only two or three signal phases which shortens the cycle length and reduce pedestrian delay. Pedestrians may have to cross an extra crossing due to the connector road. In Figure 94, the extra crossing might be on the east-west direction such as crossing 'F' or on the north-south direction such as crossing 'I'. There may be some issue in signal timing plan for the pedestrian crossing the main street at secondary intersection. For example, pedestrian crossing 'G' and 'H' in Figure 94, conflicts with the left-turn movements from the connector. These issues should be addressed carefully in the signal design in order to maneuver a desirable pedestrian mobility. Signal treatments for pedestrians with disabilities are similar to the conventional intersections. QRIs also assist pedestrians with visual or cognitive disabilities.

Similarly, bicyclists should find QRIs easier to negotiate and faster than a conventional intersection due to the relatively longer green times and progression. Bicyclists also have the choice to follow the vehicular paths at the main intersection or use the connector road which

might have an extra travel distance or follow the pedestrians' crossings at the main intersection with no extra distance to travel.

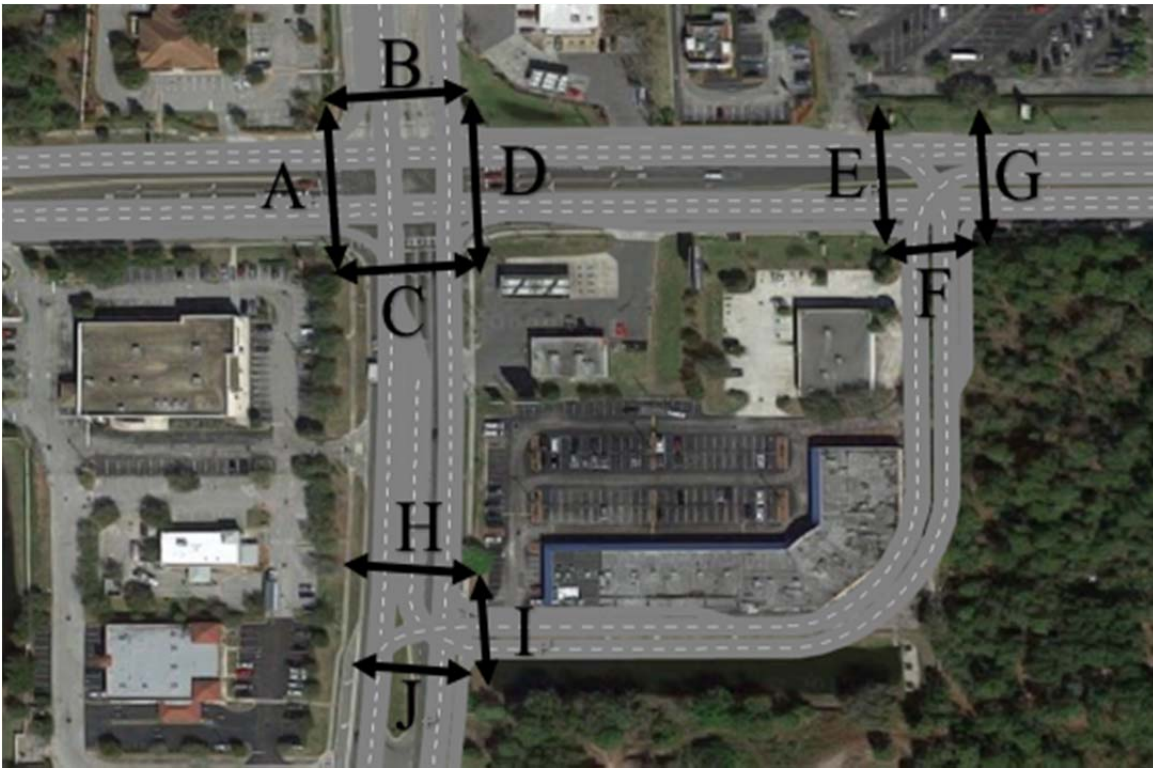

Figure 94: Crosswalks Locations at Study Intersection for QRI

3.5.4 Wayfinding

All four direct left turns at a QRI are prohibited and rerouted to different locations compared to traditional intersection. The key issue at a QRI is to convey to drivers where they need to execute left-turn maneuvers and that a right-turn is needed first to complete the turn. Advanced overhead signs at the main and secondary intersections are needed to lead unfamiliar motorists through a QRI. Additional traffic control devices needed at QRIs include pavement markings, regulatory signs, and warning signs to ensure that no left turns or U-turns are made at the main intersection. To help drivers learn how to use the QRI, agencies should consider a public information campaign before the opening of a QRI. Press releases, flyers distributed and materials posted on the agency Web site also help residents to understand how to navigate through the intersection. The materials should include information to left turning drivers on how to follow the signs. It should also indicate that motorists will experience better intersection operations with the new design.

A similar signing plan as shown in Figure 95 can be implemented in the study intersection.

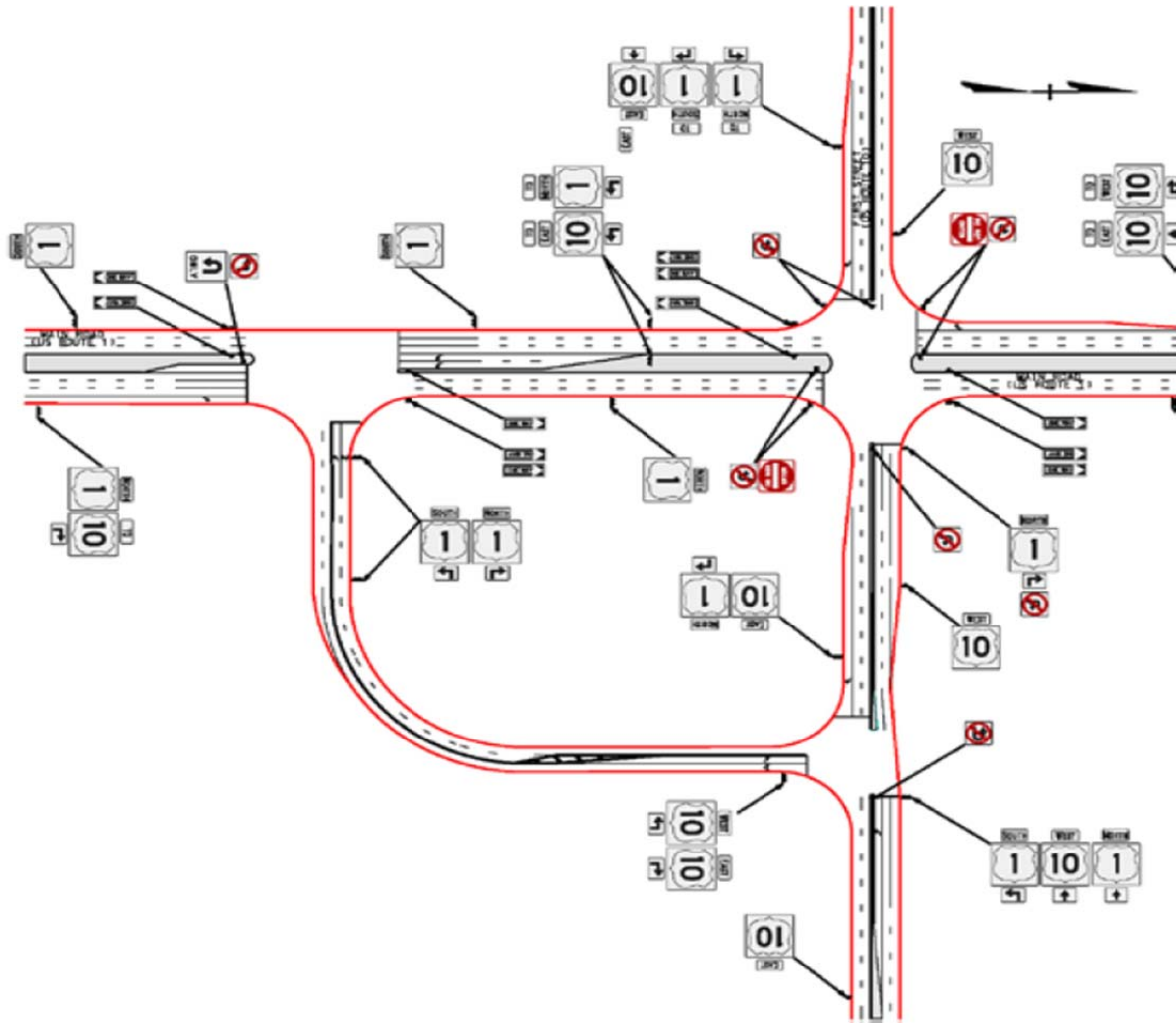

Figure 95: Typical Signing Plan for QRI

3.5.5 Signalization

At the study intersection, QRI had three signal-controlled intersections which included the main intersection reduced to a two-phase signal and two new T-intersections with three-phase signals at the ends of the connecting road. In Figure 96, intersection one is the main intersection, while intersection two and three are secondary intersections. The main challenge in the signal design for a QRI is how efficient traffic can progress through the signals. QRIs provided an adequate amount of green time for the main streets through reduction of the cycle length to two-phases. QRI signals were also fairly easy to integrate into nearby signals along the arterials. The main intersection had two phases: one for east-west and another for north-south movement. In intersection 2, it needed three phases: first one for east-west movement, second one for left-turn movement (WBL) from main road to the connector, and third one for left-turn movement from the connector to the west direction, which is used for NBL traffic. Similarly, intersection three also needed three phase signal plan. First one for north-south movement, second one for SBL movement and third one for WBL movement running from connector to south direction.

Three separate controller, one for each intersection, were used for the QRI at the study intersection. For each intersection, several trials for different signal timing plans with different cycle length and splits were tested in VISSIM model in order to find the best signal timing plan. Based on the overall network performance, the best signal timing plan was selected for the analysis.

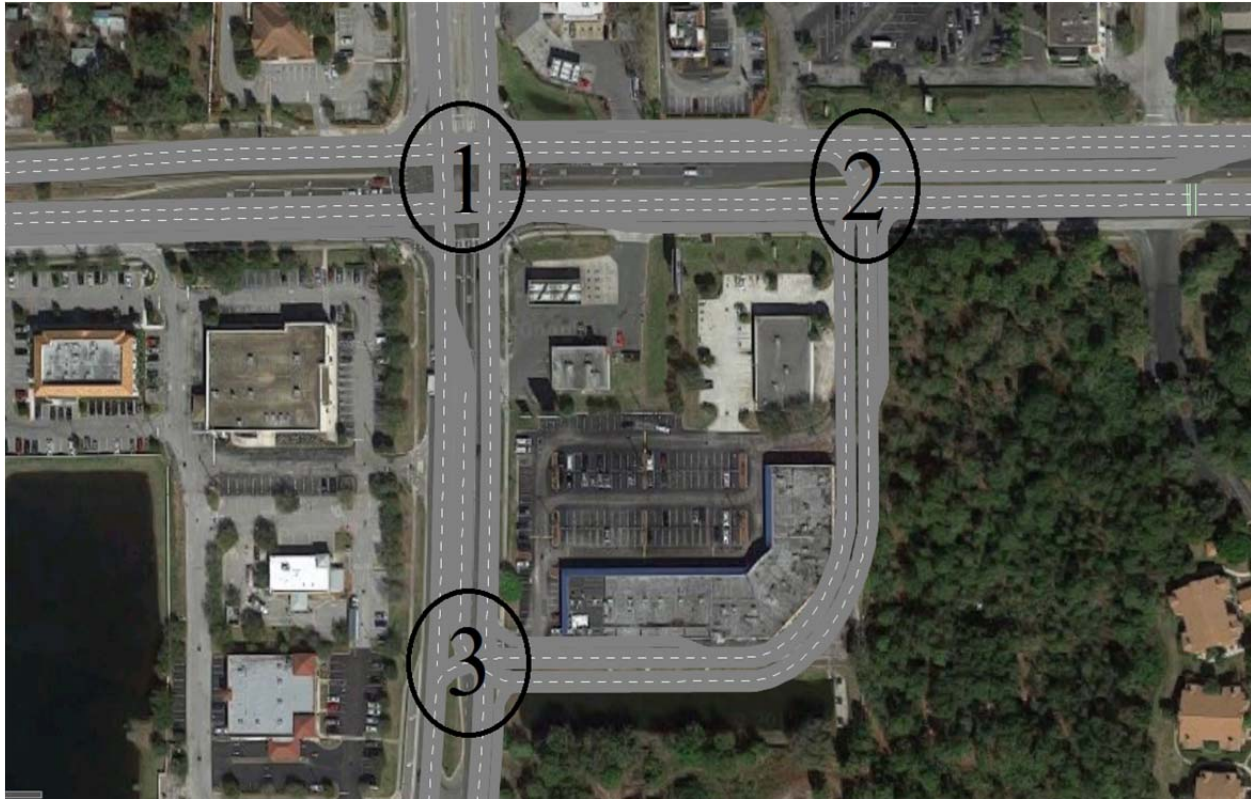

Figure 96: Signal Location for QRI at Study Intersection

3.5.6 Operational Performance

3.5.6.1 VISSIM Modeling

The comparison of operational performance between QRI and conventional intersection was made using results from a traffic microsimulation software. In this study, VISSIM was selected as the appropriate tool since VISSIM is a robust and flexible microsimulation software that can reflect the traffic condition of QRI and CI. Additionally, Synchro was also used to optimize the signal timing for the existing condition.

The study intersection was simulated using the VISSIM version 6.0. The VISSIM model was drawn over the properly scaled background picture of the study intersection obtained from Google Map. Number of lanes in each movements, storage length and other geometric features were set up same as the study intersection. Then, traffic volumes and signal timing data were assigned in the each movement group. Actual signal timing data was obtained from the City of

Orlando. The VISSIM model was calibrated and validated using the field data collected for the study intersection on March 17th, 2015.

For the analysis, comparison between CI and QRI was performed in different volume level scenario. Based on the existing traffic volume demand, five volume levels, increasing 10% volume in each volume level, were set up. Therefore, the final experiment resulted in $5 \times 2 = 10$ multilevel factorial. For each volume level, an optimized signal timing plan was used. Synchro was not best for the signal optimization, but it gave an estimate for the optimized cycle length and splits. Therefore, many trials for different signal timing plans were tested in VISSIM to figure out the best signal timings based on the overall network performance. Additionally, each experiment was simulated for 60 minutes. A total of three runs with different seeding values were completed for each scenario and the average of the runs was reported. The VISSIM models for both CI and QRI are shown in Figure 97.



Figure 97: VISSIM Model for CI and QRI

3.5.6.2 Results and Analysis

The overall network performance of CI and QRI obtained from the VISSIM simulation for each volume level is presented in Table 35. The overall network performance measures included hourly input volume, hourly throughput volume, delay per vehicle, level of service, and average speed. The throughput volume for CI differed from input volume significantly around 120% to 130% volume level, which indicated the capacity of the existing intersection.



Table 35: Overall Network Performance Measures for CI and QRI

Overall Network Performance	Volume Level	Input Volume (Veh/hr)	Throughput (Veh/hr)	Delay/Veh (Sec)	LOS	Average Speed (km/hr)
CI	100%	6675	6544	49.02	D	33.83
	110%	7343	7209	53.60	E	32.23
	120%	8010	7685	78.61	E	25.57
	130%	8678	7937	110.79	F	19.96
	140%	9345	8023	122.99	F	18.45
QRI	100%	6675	6555	31.68	C	42.18
	110%	7343	7224	35.07	D	40.45
	120%	8010	7853	38.13	D	38.97
	130%	8678	8495	47.73	D	35.03
	140%	9345	8919	73.83	E	27.33

Comparison can be made based on the overall performance results when conventional intersection is changed to QRI design. In Figure 98, the throughput volume for CI and QRI was compared for each volume level. The difference in throughput volume between CI and QRI was obvious after volume level of 120%. Also, the plot of delay versus volume level for CI and QRI is shown in Figure 99 and it was clear that QRI performed better in terms of overall delay. QRI saved the delay in each volume level ranging from 35 to 57% and maximizing at 130% volume level when compared to CI. Additionally, QRI also improved the level of service and average speed in each volume level. Therefore, it can be concluded that QRI can enhance the capacity and improve the overall network performance in the study intersection.

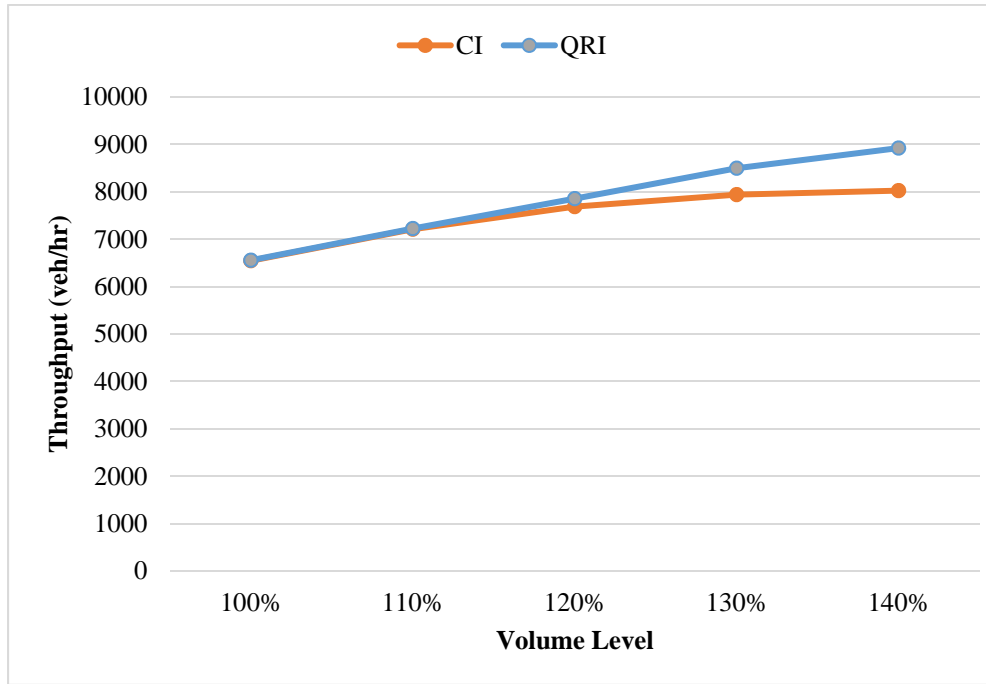

Figure 98: Volume Level versus Hourly Throughput between CI and QRI

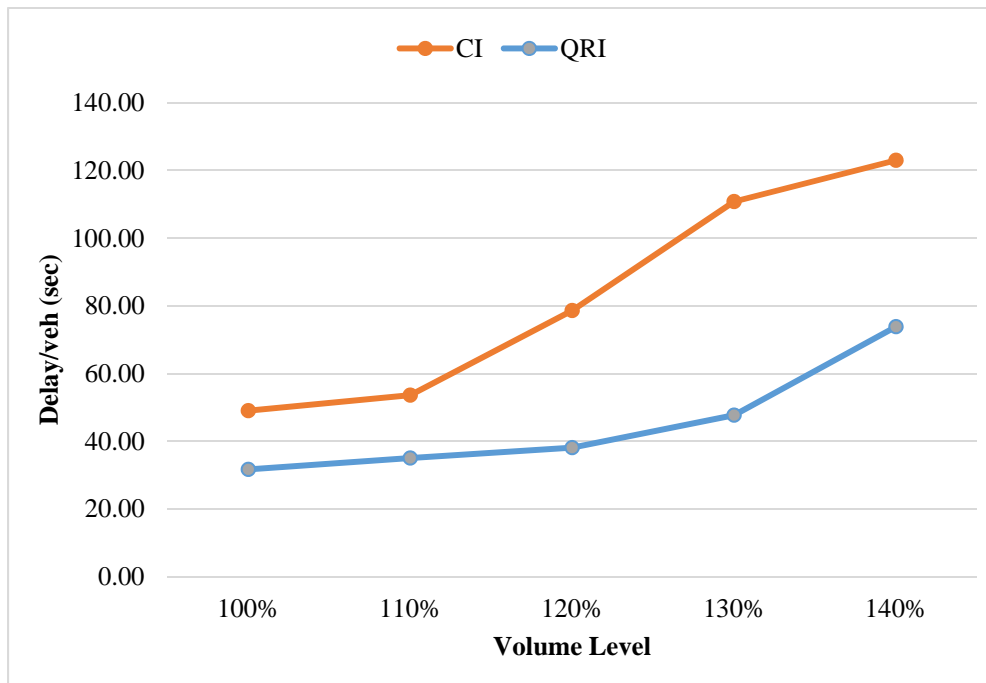

Figure 99: Volume Level versus Delay between CI and QRI



Table 36: Performance Measures Comparison by Movement — Volume Level 100%

Movement	Volume	Delay/veh (sec)		LOS		Travel Time (sec)	
		CI	QRI	CI	QRI	CI	QRI
EBL	333	88.36	41.52	F	D	115.98	98.61
EBT	1777	34.32	32.24	C	C	70.03	68.71
EBR	513	6.65	16.45	A	B	39.11	49.53
WBL	186	81.46	71.19	F	E	115.53	105.09
WBT	1832	44.44	22.78	D	C	81.15	60.21
WBR	159	37.99	12.47	D	B	64.45	38.93
SBL	278	84.12	68.55	F	E	112.01	112.69
SBT	461	63.35	28.13	E	C	89.96	55.20
SBR	107	11.52	11.09	B	B	39.00	38.85
NBL	364	75.54	51.18	E	D	106.43	96.39
NBT	474	74.06	35.24	E	D	96.56	58.20
NBR	191	66.30	22.41	E	C	95.10	50.29

Table 37: Performance Measures Comparison by Movement — Volume Level 140%

Movement	Volume	Delay/veh (sec)		LOS		Travel Time (sec)	
		CI	QRI	CI	QRI	CI	QRI
EBL	466	210.32	148.69	F	F	238.01	205.78
EBT	2488	86.68	93.24	F	F	122.49	129.74
EBR	718	22.05	43.52	C	D	54.62	76.68
WBL	260	141.45	91.45	F	F	175.61	125.39
WBT	2565	133.38	34.19	F	C	170.19	71.60
WBR	223	133.19	25.31	F	C	159.63	51.84
SBL	389	107.32	166.68	F	F	135.26	210.73
SBT	645	80.21	39.01	F	D	106.82	66.09
SBR	150	20.99	20.23	C	C	48.47	48.04
NBL	510	126.77	106.35	F	F	157.78	151.54
NBT	664	231.07	75.92	F	E	253.68	98.85
NBR	267	210.05	108.31	F	F	238.88	136.28



The operational performance measure by movement was also compared between CI and QRI. The comparison was made in terms of delay, level of service and travel time. Table 36 and Table 37 summarized the performance measures by movement for CI and QRI for the existing conditions base scenario which is at the 100% volume level as well as the 140% volume level. At 100% volume level, the delay was improved in all movement except EBR. Similarly, level of service and travel time also improved in most of the approaches. The QRI design in the study intersection had some indirect left-turn movements such as EBL, NBL, and SBL, which required to travel longer distance and go through multiple signalized intersection. Delay for all the indirect left-turn movements was reduced and travel time for EBL and NBL was also decreased. For 140% volume level, operation in QRI improved in all approach except EBT and EBR movement. The EBT movement had high volume and need to pass through two signal. Also, EBT gets lower percentage of green time compared to WBT, because EBT conflicts with WBL movement at eastside secondary intersection. Therefore, the signal failed to operate the EBT movement properly for 140% volume, resulting higher delay in EBT. However, other movements were operated efficiently leading to a very good overall network performance. Overall, operational performance was better for QRI when compared to CI. Therefore, QRI may improve the operation and capacity and it can be presented as a replacement for the study intersection.

3.5.7 Benefit to Time Saving

Construction costs for QRIs are likely higher than a conventional intersection. However, QRI produces moderate to high benefits over conventional intersection. Main components that are needed and add to the cost include the connector roadway, additional signals and overhead signs for the two extra intersections. On average, the connector roadway is about 880 feet (centerline to centerline), or 0.167 miles with 500 feet spacing between the main and secondary intersections. The average right of way is about 1.1 acres. Other costs are related to lighting, maintenance costs and enforcement needs especially during the first months of operations. The cost of the connector roadway is the greatest cost and affects the total project cost depending on the available right of way. Some of the costs associated with the QRIs could be slightly compensated by the reduced widths at the main street intersection. The right of way cost may change based on the geographical location of the intersection.

For the study intersection, the existing road located in east-south quadrant of the main intersection was used as a connector roadway. Therefore, project costs related to land acquisition for the connector roadway will be reduced. However, there will be some right of way cost for wider four lane connector roadway designed in this intersection. Delay savings by QRI compared to conventional intersection was calculated. Table 38 shows the benefit of QRI over CI in terms of delay savings in one year. The cost of delay was used \$17.67/hr as reported by Texas A&M Transportation Institute for year 2014.



Table 38: Reduction of Cost by QRI by Saving Delay

Volume Level	Total Vehicle Time Reduction (vehicle-hour/day)	One-year Cost Reduction (dollar)
100%	194.06	\$1,251,600
110%	228.53	\$1,473,916
120%	535.8	\$3,455,669
130%	849.35	\$5,477,925
140%	593.31	\$3,826,583

3.5.8 Conclusion

The analysis highlighted several important aspects regarding QRI traffic operations and demonstrated how QRI can improve the overall performance compared to the existing condition. QRI is applicable mainly for intersections with two busy sub-urban or urban roadways. QRI reroutes all four left-turn movements in a four-legged intersection using a secondary roadway connecting two intersecting roadways. Only two phases are required at the main intersection to accommodate the vehicles and pedestrians, which allocates higher percentage of green time for through movements. Elimination of left-turn lanes at main intersection provides a shorter crossing distance for pedestrians and bicyclists. Pedestrians and bicyclists get less waiting time due to the shorter cycle length at QRI. Wayfinding is very important at QRI especially for left-turning drivers who are not familiar with the intersection. The case study at this specific intersection showed that QRI intersection reduced the overall delay and travel time, and improved the level of service compared to the conventional intersection. In addition, the operational performance comparison for increased volume scenario showed that QRI can perform better than conventional intersection. Overall, QRI intersections can provide a superior alternative to heavily congested conventional intersections in terms of overall operational performance.



IV- CONCLUSIONS

Based on the various reports and case studies presented in this research along with the advantages and disadvantages of each alternative, these alternative designs proved to outperform most conventional intersections and have enhanced arterials in various ways. Although there is not much field data available for some of these new designs, micro-simulation analyses showed that they are effective and improve safety and efficiency which are usually two conflicting goals. Majority of the alternatives showed positive results through simulations and field data.

Alternative intersection treatments lower the number of conflicts at intersections and help reduce overall congestions. While these alternative designs are noticeably different from each other, there is a common aspect among them. These alternative designs all attempt to remove one or more of the critical conflicting movement from the major intersection and divide the intersection into smaller networks that would operate in a one-way fashion. Thus having fewer signal phases with shorter signal cycle lengths, shorter delays, and higher capacities compared to conventional intersections. They have been successfully implemented in Utah, North Carolina, Missouri and Louisiana. The only concern would be drivers' confusion while driving on the opposite side of the road, which can be overcome with proper signage and signalization as well as informative public hearings.

The overall analysis provided variety of parameters that needs to be considered when implementing any of these designs. These intersections can be significantly cumbersome for vehicles, bicyclists and pedestrians to navigate without proper implementation of wayfinding signs and education of the road users. However, the benefits of these designs, when applied properly, can save municipalities years of capacity and preserve the existing infrastructure for a longer period of time. These goals align with the overall goal of the FDOT TSM&O program.



REFERENCES

- Autey, J., Sayed, T., & El Esawey, M. (2012). "Operational performance comparison of four unconventional intersection designs using micro - simulation". *Journal of Advanced Transportation*, 47(5), 536-552. doi: 10.1002/atr.181.
- Bared, J. (2009a). *Quadrant Roadway Intersection*. (FHWA Publication FHWA-HRT-09-058). Washington, D.C.: Federal Highway Administration (FHWA). Available online: [http://safety.fhwa.dot.gov/intersection/resources/fhwasa09027/resources/Quadrant Roadway Intersection Tech Brief.pdf](http://safety.fhwa.dot.gov/intersection/resources/fhwasa09027/resources/Quadrant%20Roadway%20Intersection%20Tech%20Brief.pdf).
- Bared, J. (2009b). *Restricted Crossing U-Turn Intersection*. (FHWA Publication FHWA-HRT-09-059). Washington, D.C.: Federal Highway Administration (FHWA). Available online: <http://www.fhwa.dot.gov/publications/research/safety/09059/09059.pdf>
- Bared, J. G., and Edara, P. K. (2005). "Simulated Capacity of Roundabouts and Impact of Roundabout within a Progressed Signalized Road". In *National Roundabout Conference: 2005 Proceedings*, P. Demosthenes, ed. Washington, D.C.: Transportation Review Board.
- Bared, J. G., and Kaiser, E. I. (2002). "Median U-Turn Design as an Alternative Treatment for Left Turns at Signalized Intersections". *ITE Journal* 72(2), 50-54.
- Chlewicki, G. (2003). "New Interchange and Intersection Designs: The Synchronized Split-Phasing Intersection and the Diverging Diamond Interchange." In *2nd Urban Street Symposium: Uptown, Downtown, or Small Town: Designing Urban Streets That Work, July 28-30, 2003, Anaheim, CA* (CD-ROM). Washington, D.C.: Transportation Review Board. Available online: http://www.urbanstreet.info/2nd_sym_proceedings/Volume%202/Chlewicki.pdf.
- Edara, P. K., Bared, J. G., and Jagannathan, R. (2005). *Diverging Diamond Interchange and Double Crossover Intersection--Vehicle and Pedestrian Performance* (pp. 0-22).
- El Esawey, M., and Sayed, T. (2008). "Comparison of Two Unconventional Intersection Schemes: Crossover Displaced Left-Turn and Upstream Signalized Crossover Intersections". *Transportation Research Record: Journal of the Transportation Research Board*, 2023(2008 Geometric Design and the Effects on Traffic Operations 2007), 0-20. doi: 10.3141/2023-02.
- Federal Highway Administration. (2009). *Manual on Uniform Traffic Control Devices*, McLean, VA.
- Florida Department of Transportation, (2014). *Transportation Systems Management & Operations*. Available online: <http://www.dot.state.fl.us/trafficoperations/tsmo/TSMO-home.shtm>.
- Florida Department of Transportation, *Congestion in Florida: Findings from the 2011 Urban Mobility Report*.



- Hughes, W., Jagannathan, R., & Bared, J. (2009). *Double Crossover Diamond Interchange*. In *TechBrief* (Ed.). Research, Development, and Technology Turner-Fairbank Highway Research Center 300 Georgetown Pike, McLean, VA 22101-2296.
- Hughes, W., Jagannathan, R., Sengupta, D., Hummer, J., Jenior, P., Knudsen, J., Vanasse Hangen Brustlin, Inc. (VHB). (2010). *Alternative Intersections/Interchanges: Informational Report* (AIIR). (FHWA Publication No. FHWA-HRT-09-060). Washington, DC. Federal Highway Administration (FHWA). Available online: <http://www.fhwa.dot.gov/publications/research/safety/09060/09060.pdf>
- Hummer, J. E. (1998). "Unconventional Left-Turn Alternatives for Urban and Suburban Arterials-Part One". *ITE Journal*, 26-29.
- Hummer, J. E., & Reid, J. D. (2000). "Unconventional Left-Turn Alternatives for Urban and Suburban Arterials: An Update" *Transportation Research Circular* (pp. 1-17).
- Hummer, J., Wayne State University: W. S., Ray, B., Daleiden, A., Jenior, P., Knudsen, J., & Kittelson & Associates, I. (2014). *Restricted Crossing U-turn Informational Guide* (FHWA Publication FHWA-SA-14-070) U. S. Department of Transportation, Federal Highway Administration Office of Safety, 1200 New Jersey Ave., SE, Washington, DC, 2014 (pp. 186).
- Inman, V. W., & Haas, R. P. (2012). *Field Evaluation of a Restricted Crossing U-Turn Intersection*. (FHWA Publication FHWA-HRT-11-067). Federal Highway Administration (FHWA) (pp. 1-52)
- Jagannathan, R., & Bared, J. G. (2004). "Design and Operational Performance of Crossover Displaced Left-Turn Intersections". *Transportation Research Record: Journal of the Transportation Research Board*, 1881(2004 Geometric Design and the Effects on Traffic Operations), 1-10. doi: 10.3141/1881-01.
- North Carolina Department of Transportation. (2007). *Typical for Super Street Signing*. *Traffic Engineering and Safety Systems Branch*. Obtained from: <http://www.ncdot.org/doh/preconstruct/traffic/congestion/docs/RCUT.pdf>. Site last accessed January 22, 2015.
- Park, S., & Rakha, H. (2010). *Continuous Flow Intersections: A Safety and Environmental Perspective* (pp. 85-90). 2010 13th International IEEE Annual Conference on Intelligent Transportation Systems (ITSC), Madeira Island, Portugal: Virginia Tech.
- Reid, J., Sutherland, L., Brinckerhoff, P., Ray, B., Daleiden, A., Jenior, P., . . . Kittelson & Associates, I. (2014). *Median U-Turn Informational Guide* (FHWA Publication FHWA-SA-14-069), U. S. Department of Transportation, Federal Highway Administration Office of Safety, 1200 New Jersey Ave., SE, Washington, DC, 2014. (pp. 148).
- Reid, J. D. (2000). "Using Quadrant Roadways to Improve Arterial Intersection Operations". *ITE Journal*, 70(6), 34-36, 43-45.



- Retting, R. A., Persaud, B. N., Garder, P. E., & Lord, D. (2001). "Crash and Injury Reduction Following Installation of Roundabouts in the United States". *American Journal of Public Health, 91*(4), 628-631.
- Robinson, B. W., Rodegerdts, L., Scarborough, W., Kittelson, W., Troutbeck, R., Brilon, W., . . . Jacquemart, G. (2000). *Roundabouts: An Informational Guide* (FHWA Publication FHWA-RD-00-067). U. S. Department of Transportation, Federal Highway Administration Office of Safety. Kittelson & Associates, Inc. 610 SW Alder Street, Suite 700 Portland, OR 97205. (pp. 277)
- Rotoli, L. (2009). *Diverging Diamond Interchanges* (pp. 1-8). Any institutions? sources?
- Schroeder, B., Cunningham, C., Ray, B., Daleiden, A., Jenior, P., Knudsen, J., Kittelson & Associates, Inc. (2014). *Documentation of Diverging Diamond Interchange Information Guide*. (FHWA Publication FHWA-SA-14-067) U. S. Department of Transportation, Federal Highway Administration Office of Safety, 1200 New Jersey Ave., SE, Washington, DC, 2013.
- Schroeder, B., Hughes, R., Roupail, N., Cunningham, C., Salamati, K., Long, R., . . . Myers, E. (2011). *Crossing Solutions at Roundabouts and Channelized Turn Lanes for Pedestrians with Vision Disabilities*. NATIONAL COOPERATIVE HIGHWAY RESEARCH PROGRAM. (pp. 152).
- Sisiopiku, V. and Aylsworth-Bonzelet, L. (2003). "Application of Loops at Directional Crossovers," Presented at the *82nd Annual Meeting of the Transportation Research Board*. Washington, DC.
- Steyn, H., Bugg, Z., Ray, B., Daleiden, A., Jenior, P., Knudsen, J., & Kittelson & Associates, I. (2014). *Displaced Left Turn Informational Guide*. USDOT FHWA Office of Safety, Transportation. (pp. 152). Suh, Wonho, and Michael P. Hunter (2014). "Signal design for displaced left-turn intersection using Monte Carlo method." *KSCE Journal of Civil Engineering* 18.4 (2014): 1140-1149.
- Utah Department of transportation (2013). *Continuous Flow Intersection (CFI) Guideline. A UDOT Guide to Continuous Flow Intersection..*
- Utah Department of Transportation. "How to Navigate a Continue Flow Intersection." Brochure. <http://www.udot.utah.gov/main/uconowner.gf?n=1080356132239268171>. Site last accessed December 14, 2014.
- Utah Department of Transportation (UDOT). (2014). DDI Guideline: *A UDOT Guide to Diverging Diamond Interchanges*. Salt Lake City, UT: Utah Department of Transportation. Available online: <http://www.udot.utah.gov/main/uconowner.gf?n=14769524027177477>.
- You, Xiaoming, Li Li, and Wanjing Ma. (2013). "Coordinated Optimization Model for Signal Timings of Full Continuous Flow Intersections." *Transportation Research Record: Journal of the Transportation Research Board* 2356.1 (2013): 23-33.